

FILE PATH = p:\388035-p\m\l\ae\cdm\03.dgn
 G:\CH12\0137\In\CDOT\Standards\2013-08-07 CDWM Standards from AECOM Anna\CDWM_Details.cel
 9/11/2013

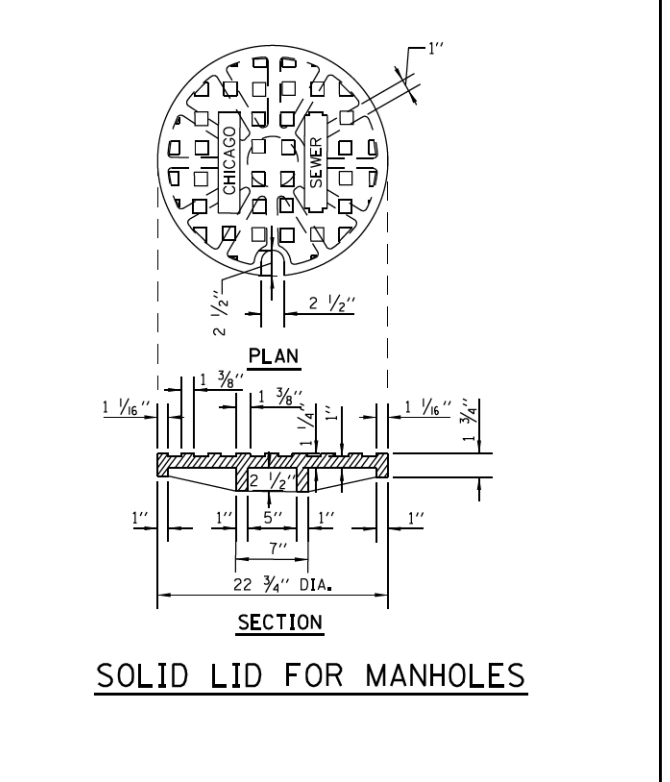
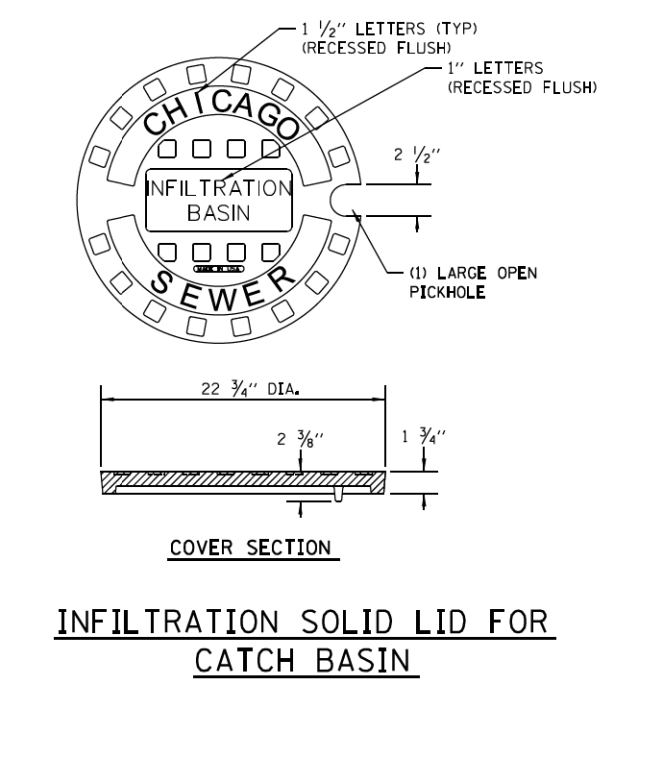
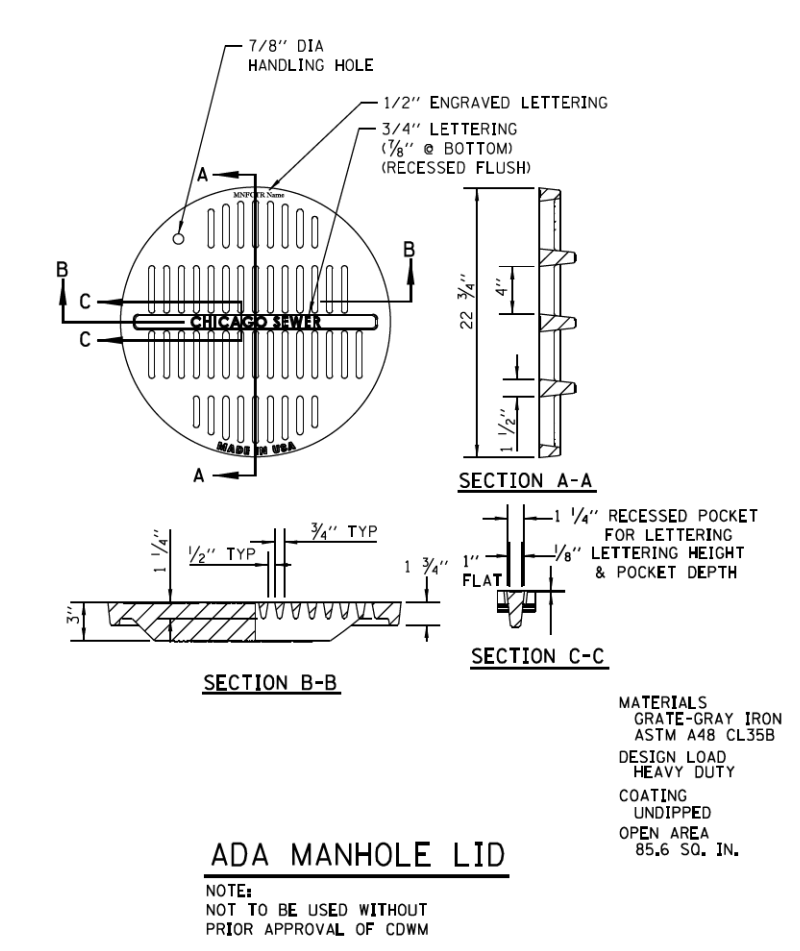
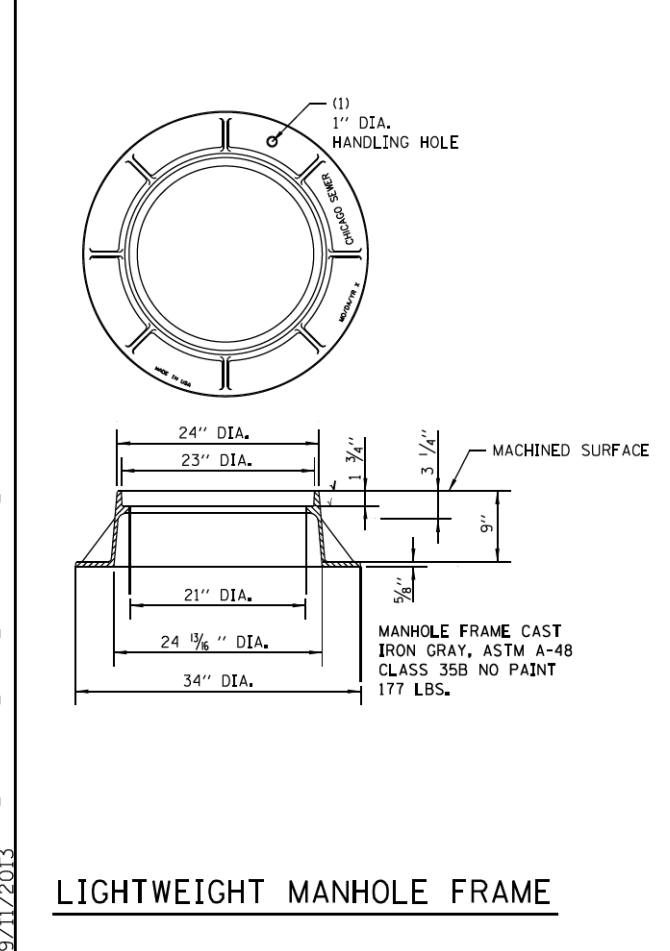
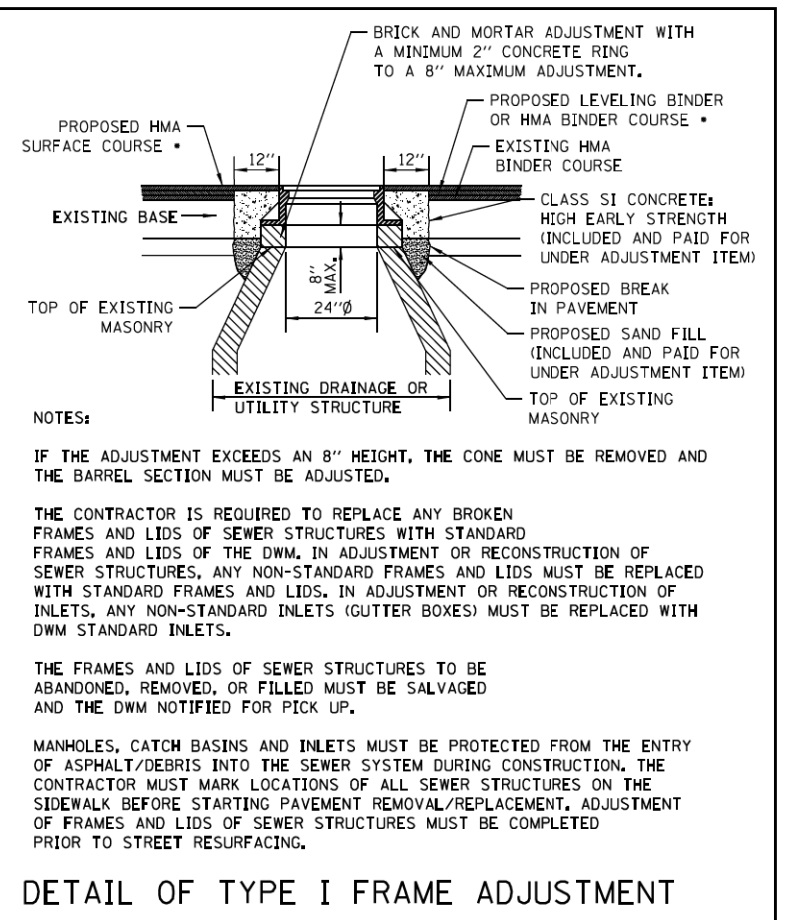
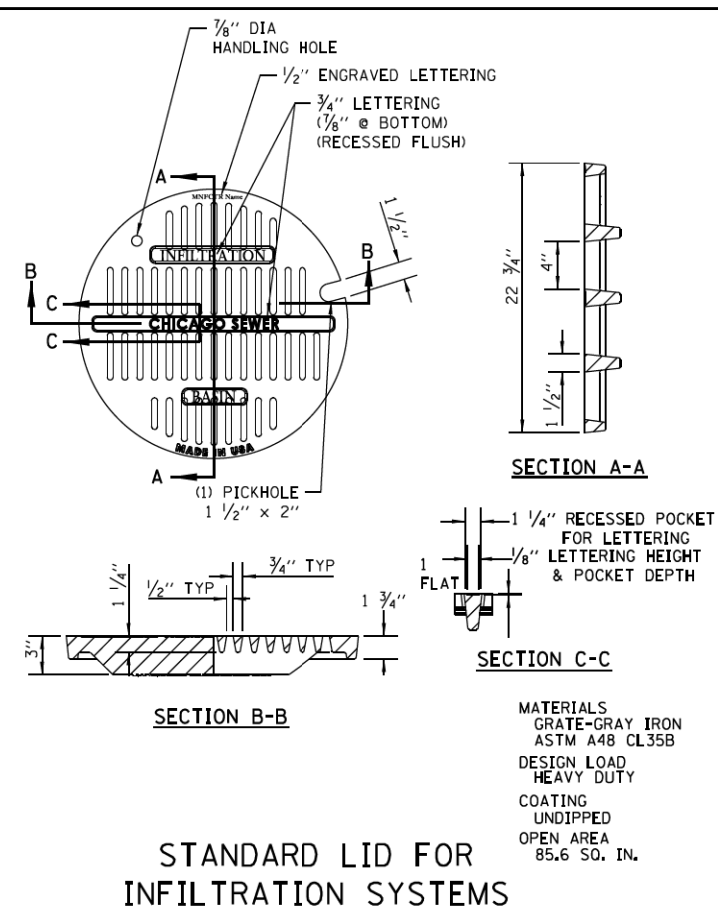
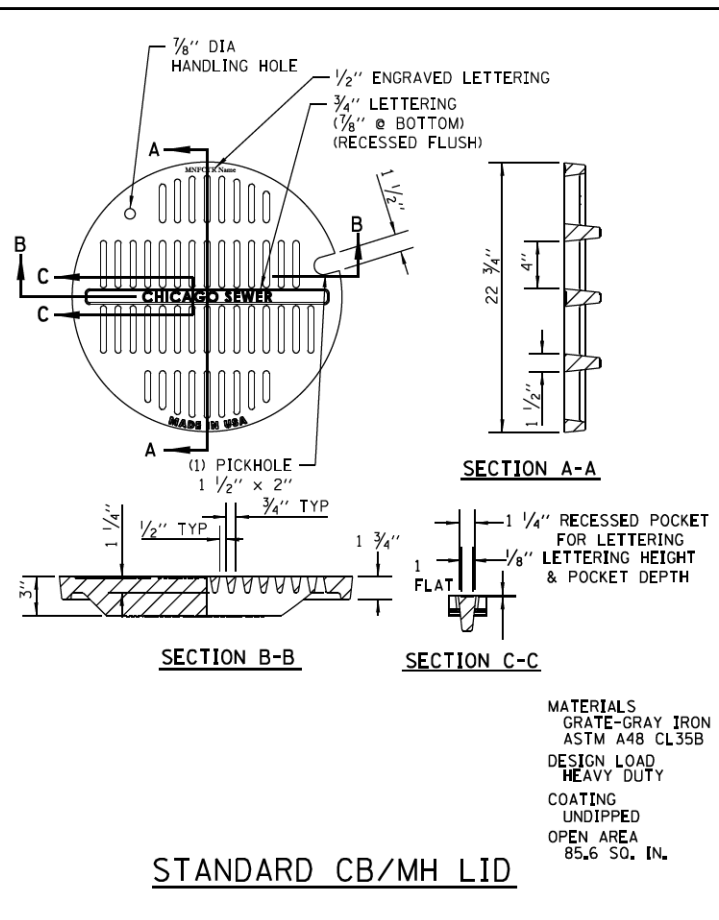
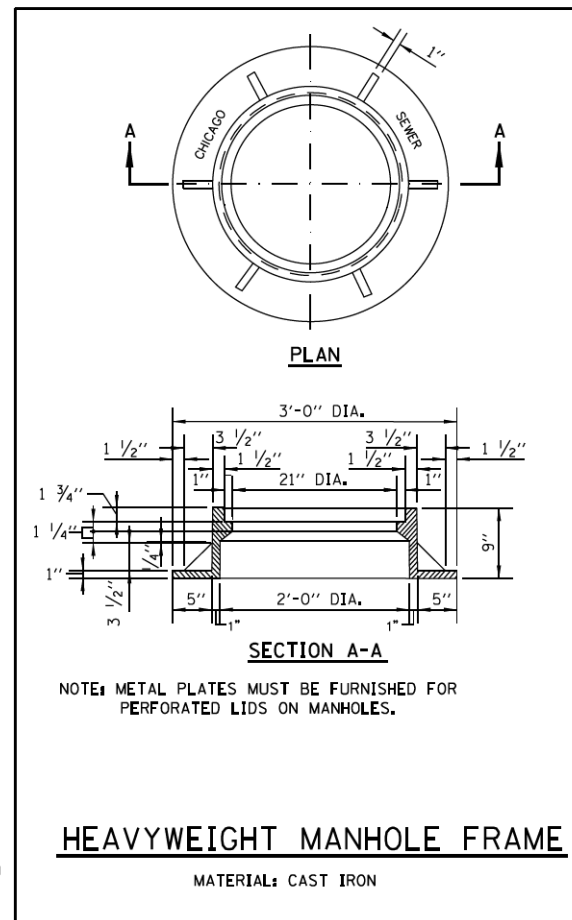

STANDARD REVISIONS	
DATE	DESCRIPTION
12/17/12	REVISED

PERCENT COMPLETE	DATE
30	
60	
75	
90	
100	
BULLETIN	

CITY OF CHICAGO	
DEPARTMENT OF WATER MANAGEMENT	
BUREAU OF ENGINEERING SERVICES	
MANHOLE LIDS AND FRAMES	

DRAWN		A.3
DESIGNED		
CHECKED		
REVIEWED		

D16029-Sht-CDWM-03.dgn	DESIGNED - CDWM	REVISED -
USER NAME = BAW1tor1	DRAWN - CDWM	REVISED -
PLOT SCALE = 2.0000' / in.	CHECKED - CDWM	REVISED -
PLOT DATE = 10/28/2013	DATE - 10/30/2013	REVISED -

STATE OF ILLINOIS
 DEPARTMENT OF TRANSPORTATION

CITY OF CHICAGO - DEPARTMENT OF WATER MANAGEMENT
 STANDARD DETAILS A.3

SCALE: NONE SHEET 3 OF 6 SHEETS STA. TO STA.

F.A.I. RTE.	SECTION	COUNTY	TOTAL SHEETS	SHEET NO.
90/94/290	2013-011R	COOK	356	343
ILLINOIS FED. AID PROJECT			CONTRACT NO. 60W29	