

**PARTIAL ELEVATION GIRDER 1**  
(Looking South)

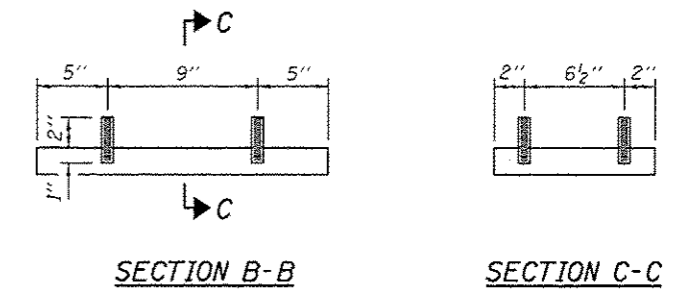

**DIMENSION A**

Girder	Dim. A
#1	2 1/2"
#2	2 1/2"
#3	1 1/2"

\* Field Drill holes using existing holes as template.

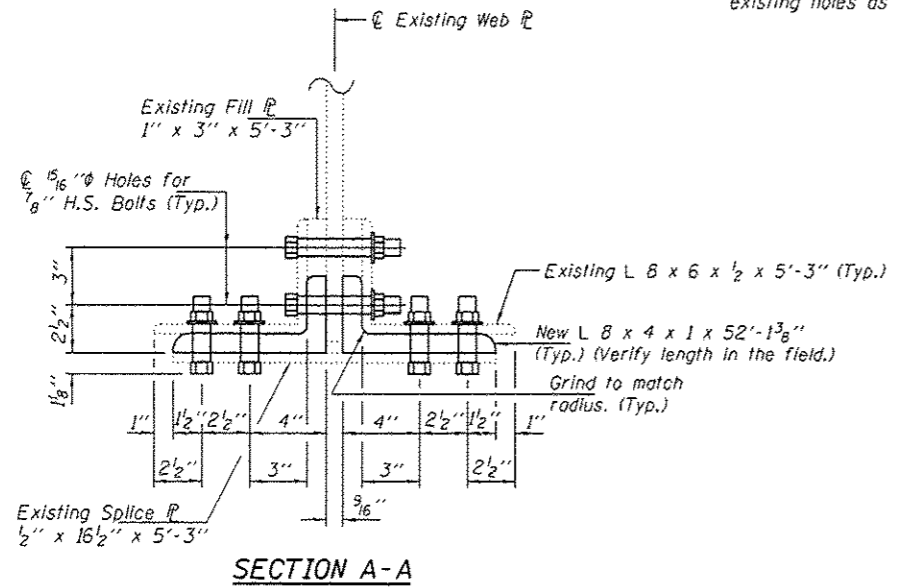

**SECTION A-A**

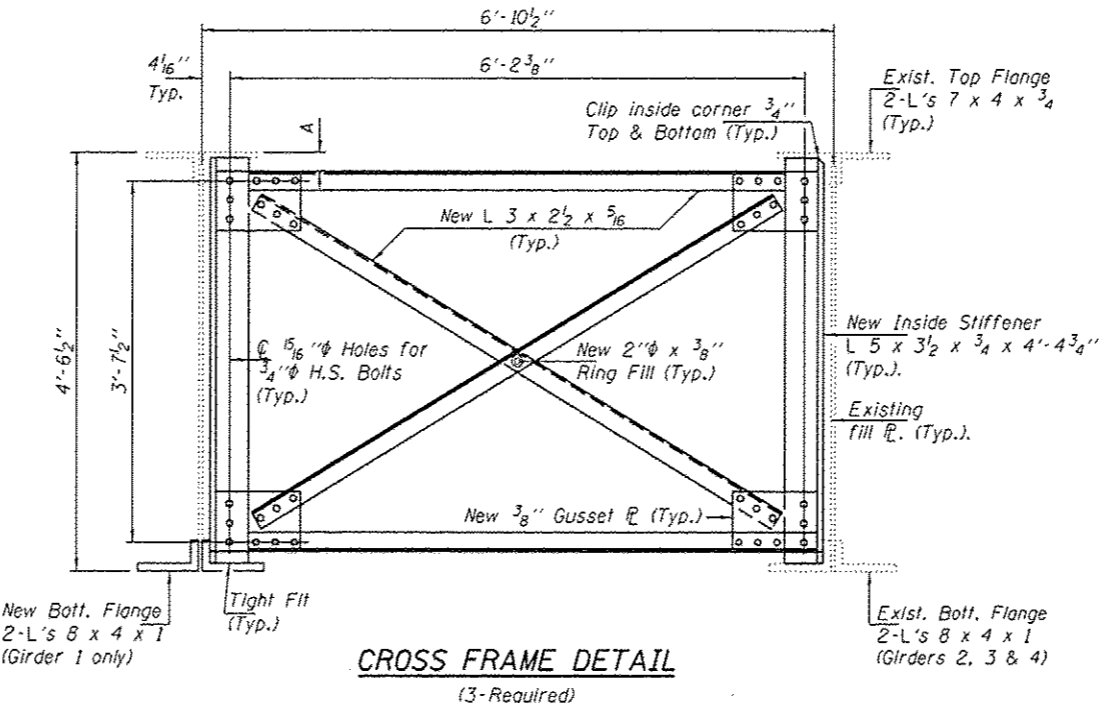

**CROSS FRAME DETAIL**  
(13-Required)

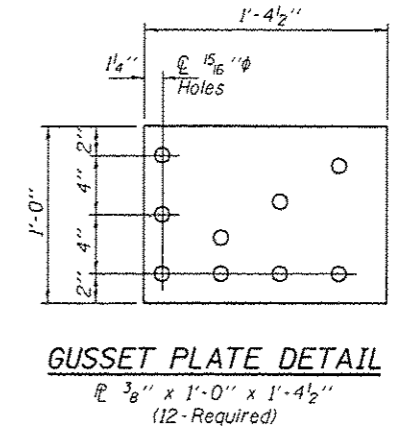

**GUSSET PLATE DETAIL**  
12-Required

Note:  
Length of New L's, size and location of holes shall be determined or verified from existing L's.  
Existing Stiffener Fill's to be salvaged.