

EXISTING TYPICAL SECTION
CLAIRE BOULEVARD
STA 47+33 TO STA 48+63

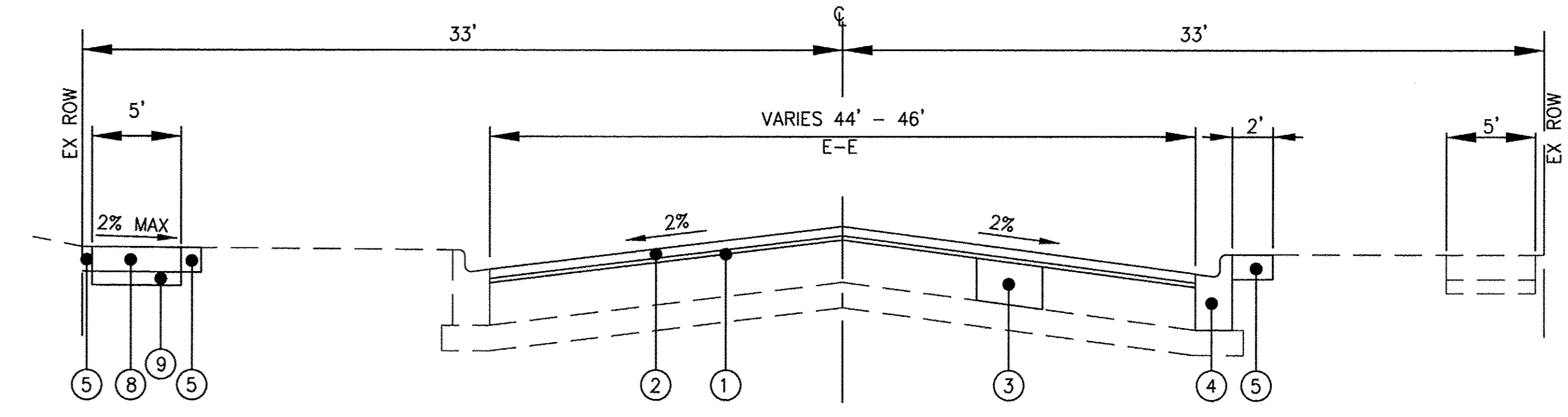

PROPOSED TYPICAL SECTION
CLAIRE BOULEVARD
STA 47+33 TO STA 48+63

EXISTING PAVEMENT DATA

CORE NUMBER	HMA THICKNESS	PCC BASE THICKNESS
B-8	6.5	6
B-9	6.5	10
B-10	5.25	10.25
B-12	5	10
B-13	5.5	9.75
B-14	4	10
B-16	4	11.5

LEGEND

- | EXISTING | PROPOSED |
|---|--|
| (A) EXISTING HOT-MIX ASPHALT SURFACE | (1) POLYMERIZED LEVELING BINDER (MACHINE METHOD), IL-4.75, N50 - 3" |
| (B) EXISTING AGGREGATE BASE | (2) HOT-MIX ASPHALT SURFACE COURSE, MIX "D", N50 - 1 1/2" |
| (C) RESERVED | (3) CLASS D PATCHES - 14" (AS DETERMINED BY THE ENGINEER) |
| (D) EXISTING SIDEWALK | (4) COMBINATION CONCRETE CURB AND GUTTER REMOVAL AND REPLACEMENT (AS DETERMINED BY THE ENGINEER) |
| (E) EXISTING COMBINATION CONCRETE CURB AND GUTTER | (5) TOPSOIL FURNISH AND PLACE, 4"; SODDING |
| (F) EXISTING AGGREGATE SHOULDER | (6) AGGREGATE WEDGE SHOULDER, TYPE B |
| (G) EXISTING PCC BASE COURSE | (7) RESERVED |
| (H) HOT-MIX ASPHALT SURFACE REMOVAL - 2" | (8) PCC SIDEWALK, 5-INCH (AS DETERMINED BY THE ENGINEER) |
| (J) SIDEWALK REMOVAL | (9) AGGREGATE BASE COURSE, TYPE B, 4" |
| (K) EXCAVATING AND GRADING OF EXISTING SHOULDER (AS DETERMINED BY THE ENGINEER) | |
| (L) AGGREGATE BASE COURSE REMOVAL (NOT PAID FOR SEPARATELY) | |
| (M) REMOVAL AND DISPOSAL OF UNSUITABLE MATERIAL (TOPSOIL) (NOT PAID FOR SEPARATELY WHEN ADJACENT TO EXISTING SIDEWALK OR CURB AND GUTTER) | |
| [Hatched Box] ITEMS TO BE REMOVED | |

COPYRIGHT © 2013, BY BAXTER & WOODMAN, INC.
 STATE OF ILLINOIS - PROFESSIONAL DESIGN FIRM
 LICENSE NO. - BR4-00121 - EXPIRES 4/30/2015
 11/25/2013 3:03:32 PM
 I:\CrystalLake\ARBNS\13009140-Claire Blvd\CADD\Drawings\Claire South\130091SHT-TypSec.dgn

BAXTER & WOODMAN Consulting Engineers	DESIGNED - JDM	REVISED - Δ 2-20-14
	DRAWN - KAR	REVISED -
	CHECKED - MWP	REVISED -
	DATE - 10-18-13	FILE - 130091SHT-TypSec.dgn

STATE OF ILLINOIS
DEPARTMENT OF TRANSPORTATION

TYPICAL SECTIONS	
SCALE: NONE	STA. TO STA.

F.A.U. RTE. 1008	SECTION 13-00028-00-RS	COUNTY COOK	TOTAL SHEETS 17	SHEET NO. 6
FED. ROAD DIST. NO. ILLINOIS FED. AID PROJECT M-4003(255)			CONTRACT NO. 61A06	