

**GENERAL NOTES**

Box Culvert End Sections shall be constructed according to the requirements of Section 540 of the Standard Specifications except as modified herein. This work will be measured for payment as each, with each end of each culvert being one each. End sections will be paid for at the contract unit price per each for Box Culvert End Sections of the culvert number specified.

Typical box section dimensions, materials, and reinforcement details for Box Culvert End Sections shall be according to the requirements of ASTM C 1577 as required for the design of the portion of the culvert within the limits of Precast Concrete Box Culverts except as modified herein.

Number of segments shown in Side Elevation is for example only. Length and number of precast box sections required to construct Box Culvert End Sections shall be determined by the Contractor.

See roadway plans for embankment slope (V:H).

1"  $\phi$  anchor rods for the culvert ties shall conform to the requirements of ASTM F1554, Grade 105. Structural steel for tie plate and restraint angle shall conform to the requirements of Article 1006.04 of the Standard Specifications. All components of the culvert tie detail shall be galvanized according to the requirements of AASHTO M 111 or M 232 as applicable. 2 1/4" x 2 1/4" x 5/16" plate washers shall be provided under each nut required for the anchor rods. Anchor rods connecting precast sections shall be brought to a snug tight condition followed by an additional 1/2 turn on one of the nuts. Match marks shall be provided on the bolt and nut to verify relative rotation between the bolt and the nut. Holes in the walls for the culvert tie assembly may be drilled using core bits in lieu of using formed holes.

All costs associated with furnishing and installing or constructing the geotextile fabric, toewall, and culvert ties will not be measured for payment but shall be included in the contract unit price for Box Culvert End Sections of the culvert number specified.

Reinforcement bars designated (E) shall be epoxy coated.

Drain holes shall conform to the requirements of Article 503.11 of the Standard Specifications unless noted otherwise.

Nonwoven geotextile fabric shall conform to the requirements of Article 1080.01. The minimum weight of the fabric shall be 6 oz. / sq. yd..

For end sections with traversable pipe grate systems, see grate detail sheet for required modifications.

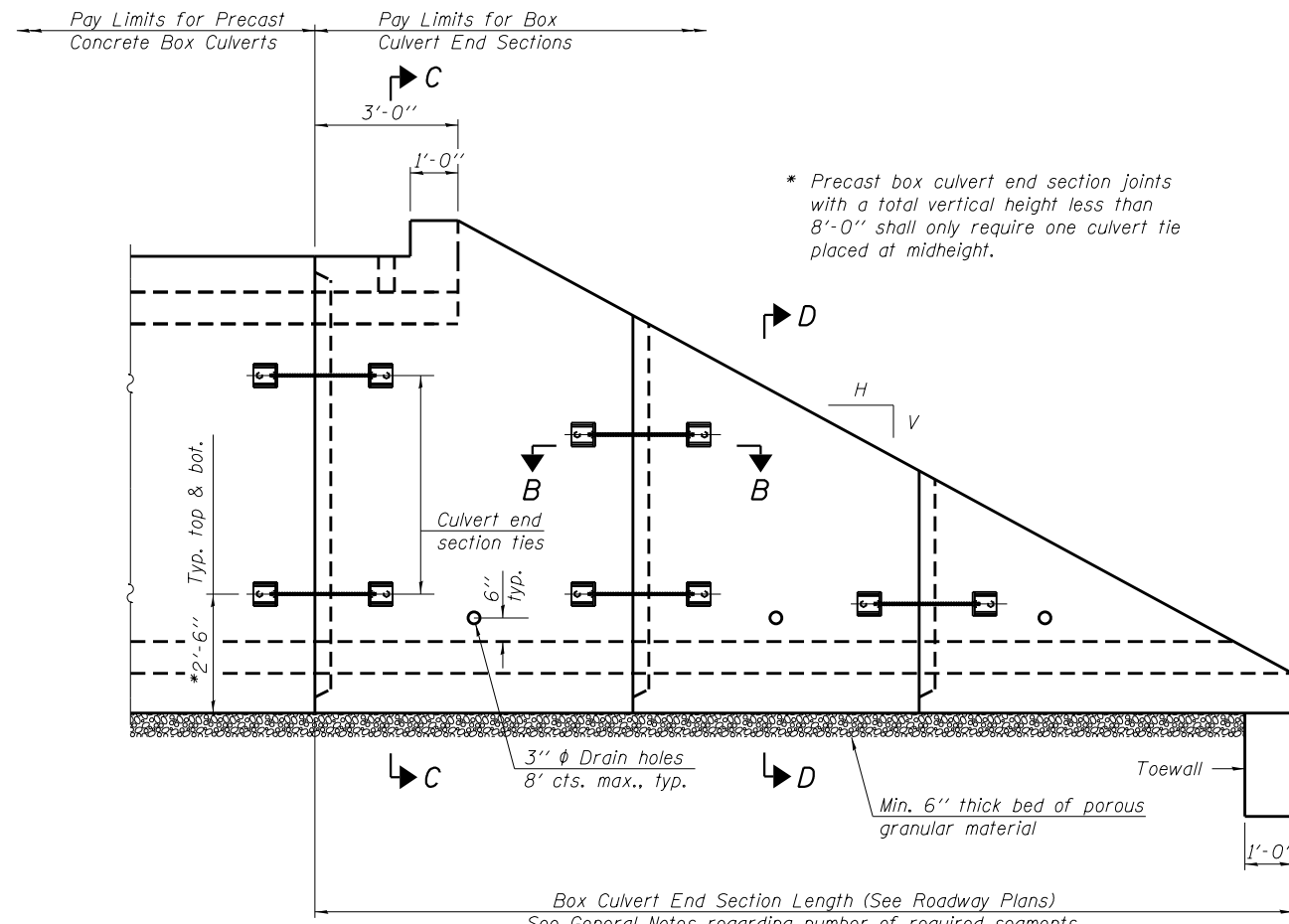

**ELEVATION**

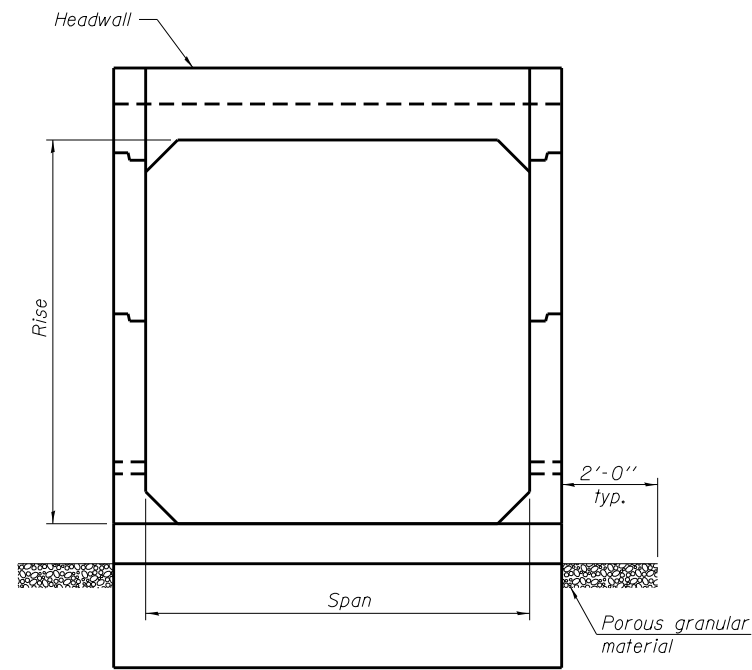

**END VIEW**

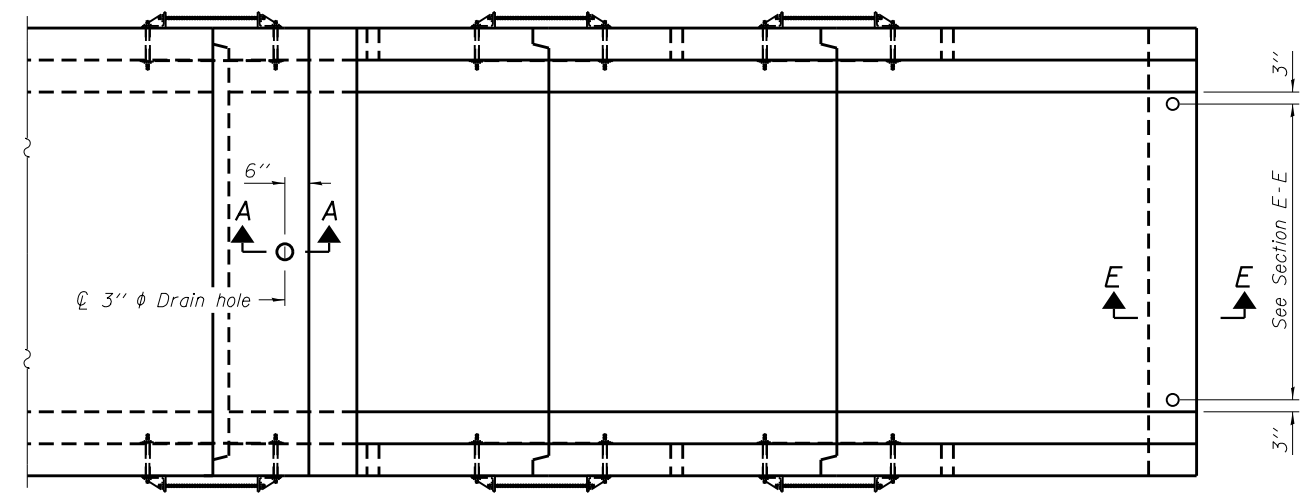

**PLAN**

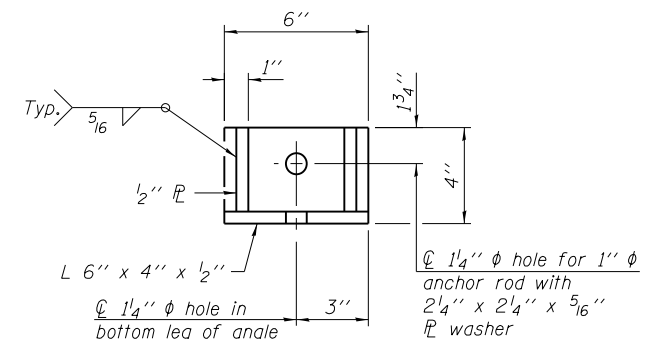

**RESTRAINT ANGLE DETAIL**

12" x 12" block of CA5, CA7, or CA11 coarse aggregate placed over drain opening. Block of aggregate shall be completely wrapped in nonwoven geotextile fabric.

Provide a double layer of 12" x 12" nonwoven geotextile fabric centered over the drain hole. Fabric shall be sealed to the concrete with mastic.

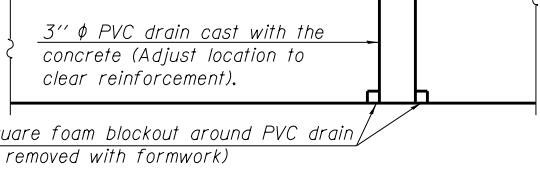

**SECTION A-A**

(All costs associated with furnishing and constructing the above drain details will not be measured for payment but shall be included in the contract unit price for the end section.)

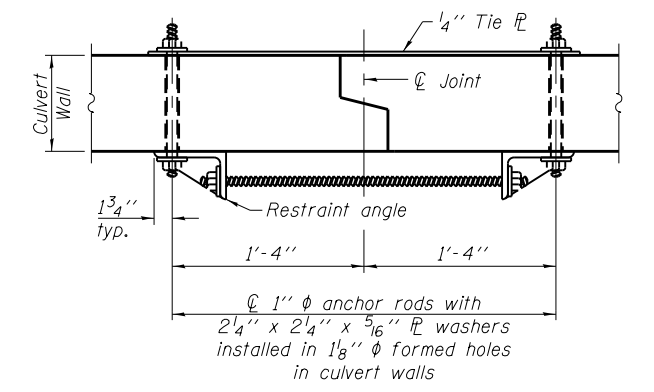

**SECTION B-B**

(Showing end section tie details)

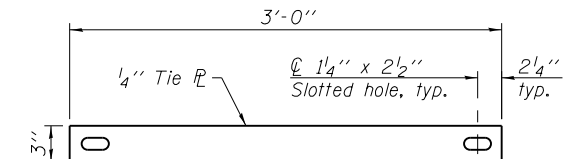

**TIE PLATE DETAIL**

10-16-12

FILE NAME D206911-sht-singlecelldetail.dgn	DESIGNED -	REVISED -
	CHECKED -	REVISED -
PLOT DATE Wed Oct 02 08:55:29 2013	DRAWN -	REVISED -
	CHECKED -	REVISED -

**STATE OF ILLINOIS  
DEPARTMENT OF TRANSPORTATION**

**SINGLE CELL PRECAST BOX CULVERT END SECTIONS**

SHEET NO. 1 OF 2 SHEETS

F.A.P. RTE.	SECTION	COUNTY	TOTAL SHEETS	SHEET NO.
505	(W-15D)T-2	WINNEBAGO	41	29
CONTRACT NO. 64H04				

ILLINOIS FED. AID PROJECT

(Sheet 1 of 2)