

SECTION THRU PARAPET
(SPANS 1 THRU 18)

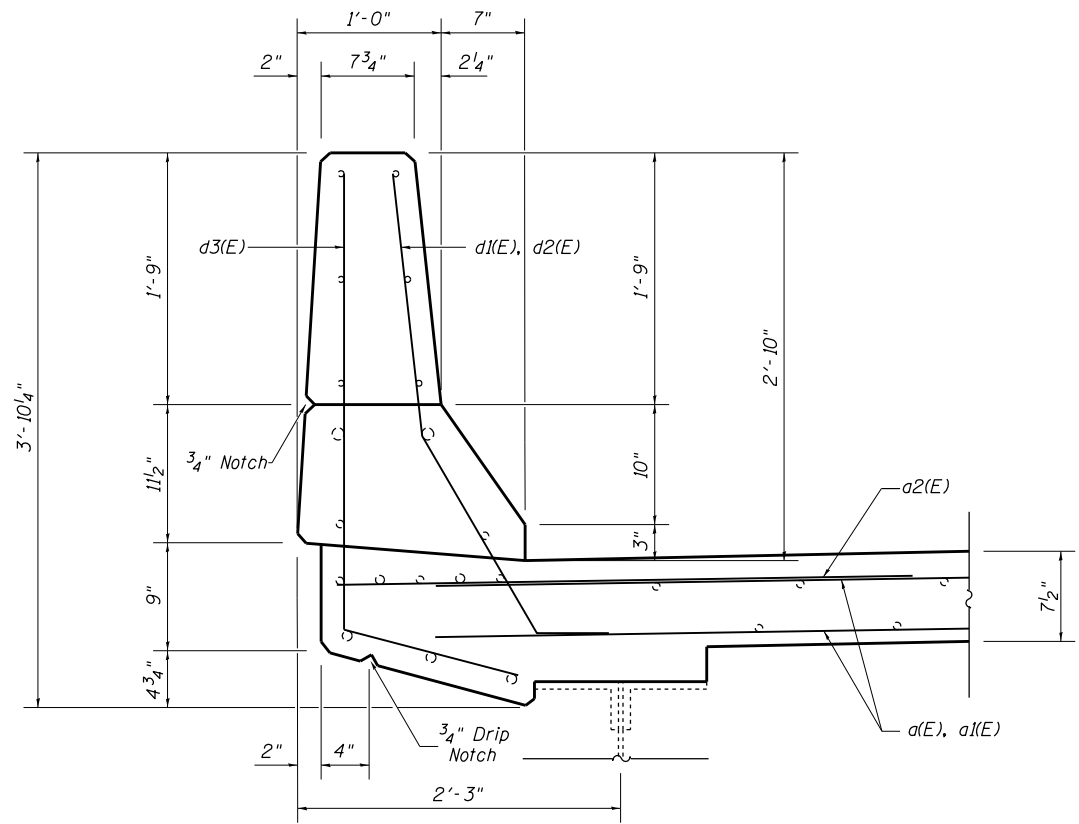

SECTION THRU PARAPET
(SPANS 19 THRU 21)

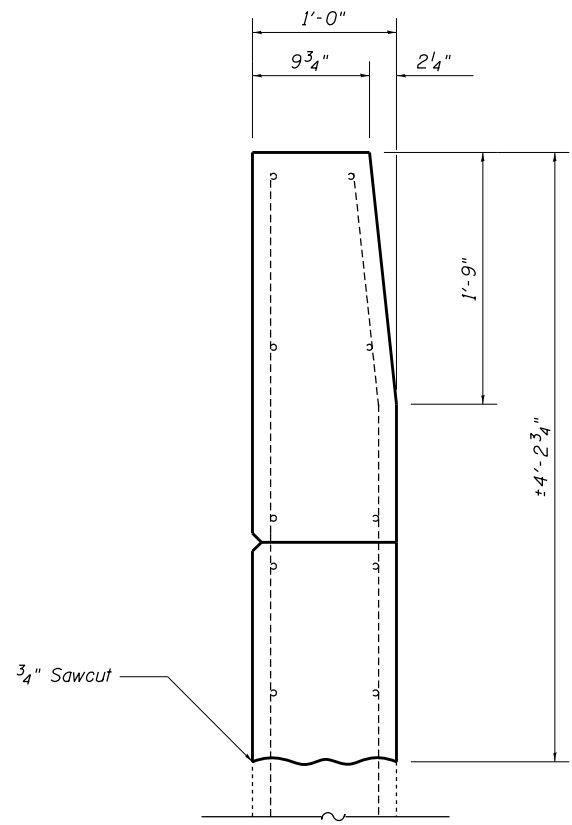

**TYPICAL WINGWALL
REMOVAL & REPLACEMENT**

FILE NAME =	USER NAME = steffenmk	DESIGNED - MJM	REVISED -
ci:\pw\work\p\idot\steffenmk\d0340638\074618-sh-t-brd\details-0960010.dgn		DRAWN - MJM	REVISED -
Default	PLOT SCALE = 40.0000' / in.	CHECKED - MEA	REVISED -
	PLOT DATE = 12/6/2013	DATE - 08/13/2013	REVISED -

**STATE OF ILLINOIS
DEPARTMENT OF TRANSPORTATION**

**EXPANSION JOINT REPLACEMENT DETAILS
SN. 096-0010**

SCALE: N/A SHEET 14 OF 35 SHEETS STA. TO STA.

F.A.P. RTE.	SECTION	COUNTY	TOTAL SHEETS	SHEET NO.
823	07 BRIDGE REPAIRS 2014-3	WAYNE	60	35
CONTRACT NO. 74618			ILLINOIS FED. AID PROJECT	