

EXISTING TYPICAL CROSS SECTION

**LEGEND**

- ① EXISTING HMA SURFACE ± 2 1/2" (AFTER MILLING)
- ② EXISTING PCC BASE COURSE 10"
- ③ EXISTING COMB. CONCRETE CURB & GUTTER, TYPE B 6.12 OR 6.24
- ④ EXISTING CONCRETE BARRIER MEDIAN
- ⑤ PROP. HMA SURFACE REMOVAL, 2 1/2"
- ⑥ PROP. POLYMERIZED LEVELING BINDER (MM), IL-4.75, N50, 3/4"
- ⑦ PROP. POLYMERIZED HMA SURFACE COURSE, MIX "F", N90, 1 3/4"
- ⑧ PROP. CORRUGATED MEDIAN REMOVAL

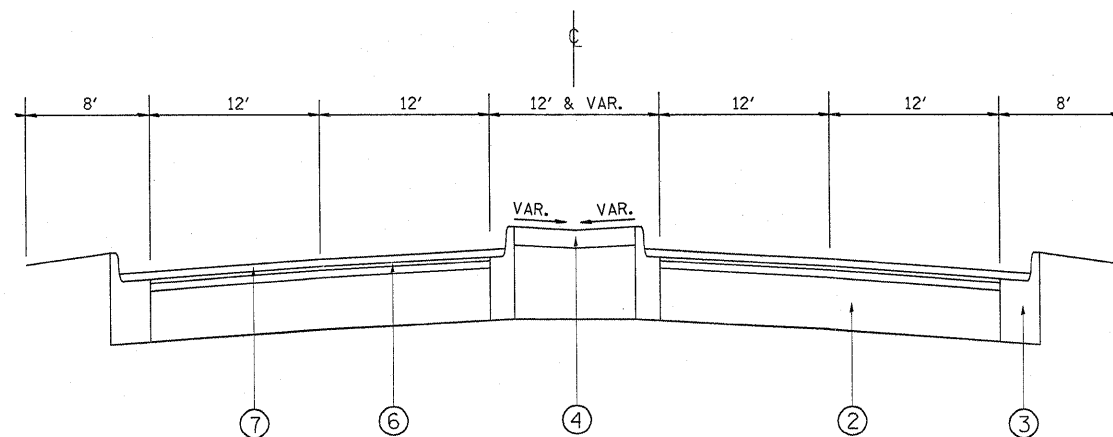

PROPOSED TYPICAL CROSS SECTION

HMA MIXTURE REQUIREMENTS	
MIXTURE USES	% VOIDS @ Ndes
POLY. HMA SURFACE COURSE, MIX "F", N90 (IL 9.5 mm)	4% @ 90 GYR.
POLY. LEVELING BINDER (MM), IL-4.75, N50	4% @ 50 GYR.
CLASS D PATCHES (HMA BINDER IL-19 mm)	4% @ 70 GYR.

- THE UNIT WEIGHT USED TO CALCULATE ALL HMA SURFACE MIXTURES IS 112 LBS/SQ YD/IN
- THE "AC TYPE" FOR POLYMERIZED HMA MIXES SHALL BE "SBS/SBR PG 70 -22" AND FOR NON-POLYMERIZED HMA THE "AC TYPE" SHALL BE "PG 64 -22" UNLESS MODIFIED BY DISTRICT ONE SPECIAL PROVISIONS. FOR "PERCENT OF RAP" SEE DISTRICT ONE SPECIAL PROVISIONS.

**NOTE:**

THE CONTRACTOR SHALL MILL FIRST BEFORE PATCHING