

DATE	
BY	
DESIGNED	
CHECKED	
PLANNED	
NOTED	
NO.	
FILE NAME	

DATE	
BY	
DESIGNED	
CHECKED	
PLANNED	
NOTED	
NO.	
FILE NAME	

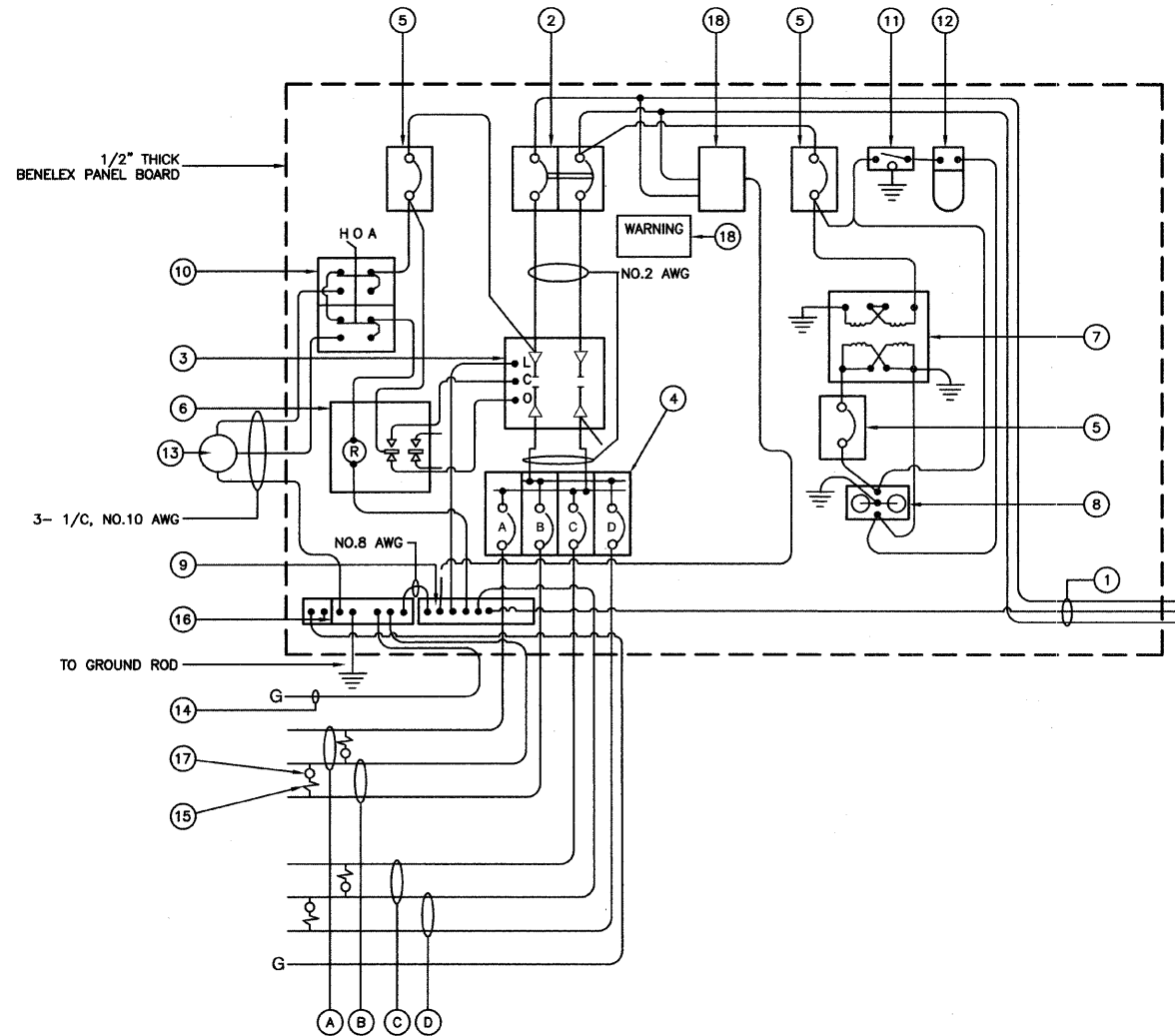

CONTROLLER WIRING DIAGRAM
CONTROLLER #1

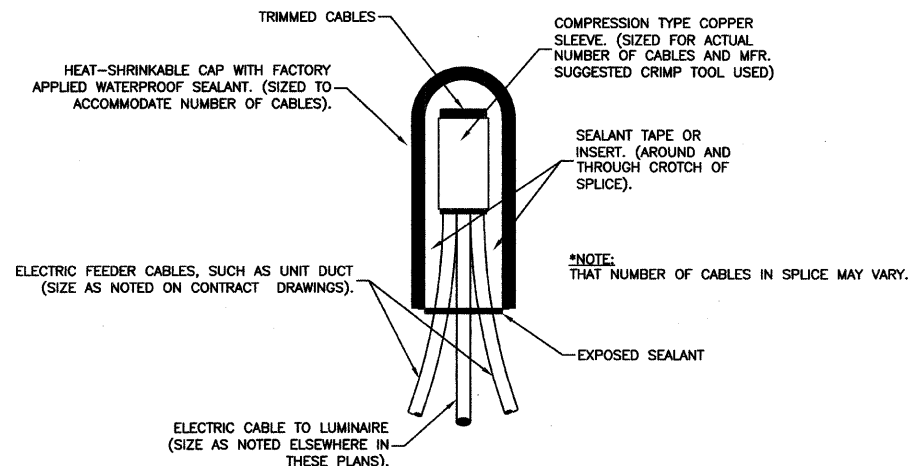

SPLICING ELECTRIC CABLES
BASIC MATERIALS AND METHODS

CONTROLLER WIRING DIAGRAM LEGEND

- ① 3-1/C, NO. 1/0 600V SERVICE WIRE IN 2" DIA GALVANIZED STEEL CONDUIT FOR 240/480 VOLT, 1Ø, 3 WIRE, 60HZ. SERVICE.
 - ② (1) 60 AMP MAIN CIRCUIT BREAKER, 2 POLE, 600 VOLT, 100 AMP BASE, NON-INTERCHANGEABLE TRIP INTERRUPTING RATING NEMA - 14000 AMP AT 480 V.
 - ③ (1) 60 AMP CONTACTOR SWITCH, ELECTRICALLY OPERATED, MECHANICALLY HELD, 2 POLE, 600 VOLT
 - ④ (4) 30 AMP CIRCUIT BREAKER, 1 POLE, 240 VOLT, 100 AMP BASE, NON-INTERCHANGEABLE TRIP INTERRUPTING RATING NEMA - 14000 AMP AT 240 VOLTS.
 - ⑤ (3) 20 AMP CONTROL CIRCUIT-CIRCUIT BREAKER, 1 POLE, 240 VOLT, 100 AMP BASE, NON-INTERCHANGEABLE TRIP INTERRUPTING RATING NEMA 14000 AMP AT 240 V.
 - ⑥ (1) 20 AMP, 1 POLE DOUBLE THROW, 240 VOLT RELAY
 - ⑦ (1) 1.5 KVA, SINGLE PHASE, ENCAPSULATED TRANSFORMER 240 X 480/120 X 240 VOLT, 60HZ.
 - ⑧ (1) 20 AMP, 120 VOLT DUPLEX GFCI RECEPTACLE.
 - ⑨ NEUTRAL BUS BAR, 1/4"x1"x12" LONG MOUNTED ON PANEL WITH TAPS.
 - ⑩ 3 POSITION SELECTOR SWITCH
 - ⑪ SWITCH FOR LIGHTING FIXTURE MOUNTED IN BOX.
 - ⑫ WEATHER-PROOF INCANDESCENT LIGHTING FIXTURE WITH 60 WATT, 120 V LAMP.
 - ⑬ PHOTOCCELL MOUNTED TO CABINET, 240 V.
 - ⑭ NO.2 AWG INSULATED GROUND WIRE
 - ⑮ IN-LINE FUSEHOLDER WITH FUSE AS NOTED IN FUSE TABLE
 - ⑯ GROUND BUS BAR 1/4"x1"x12" MINIMUM LENGTH MOUNTED ON PANEL WITH TAPS.
 - ⑰ LUMINAIRE
 - ⑱ WARNING PLATE TO READ: WARNING, MAINTENANCE CIRCUIT IS LIVE WHEN MAIN BREAKER IS SWITCHED OFF.
- (A) CIRCUIT (RED)
(B) CIRCUIT (BLACK)
(C) CIRCUIT (RED)
(D) CIRCUIT (BLACK)

GENERAL NOTES FOR CONTROL CABINET

1. ENTIRE CONTROL CABINET SHALL BE GROUNDED.
2. ALL WIRING SHALL BE TAGGED WITH SELF-STICKING WIRE MARKERS.
3. GROUND BUS TO BE COLOR CODED GREEN, NEUTRAL BUS WHITE, AND BONDED TO CABINET ENCLOSURE, BY LISTED PRESSURE CONNECTORS OR LISTED CLAMPS.
4. ALL INTERNAL CONTROLLER WIRING TO BE NO.12 AWG UNLESS OTHERWISE SPECIFIED.
5. CABINET WIRING INSULATION TO BE TYPE XHHW OR APPROVED EQUAL.

LIGHTING GENERAL NOTES

1. ALL WORK TO CONFORM TO THE MOST RECENT NATIONAL ELECTRICAL CODE AND ANY APPLICABLE LOCAL CODES.
2. CONTRACTOR TO VERIFY LOCATION OF ALL UNDERGROUND UTILITIES BEFORE TRENCHING OR AUGERING.
3. BEFORE INSTALLING STANDARDS NEAR OVERHEAD FACILITIES CALL ComEd FOR APPROVAL OF LOCATION.
4. FOR LOCATION OF EXISTING UNDERGROUND ELECTRICAL CABLE CALL ComEd.
5. CONTRACTOR SHALL TAKE ALL NECESSARY MEASURES TO RESTORE ANY SPECIALIZED LANDSCAPING, (I.E. DECORATIVE ROCKS, SHRUBS, PLANTS, ECT.) OR SHALL REPLACE IT, THE COST OF WHICH SHALL BE CONSIDERED INCIDENTAL TO THE CONTRACT.
6. CARE IS TO BE TAKEN AS NOT TO DAMAGE ANY OF THE EXISTING TRAFFIC SIGNAL CONDUIT, MAGNETIC DETECTORS AND EQUIPMENT. IF ANY OF THE TRAFFIC SIGNAL CONDUIT AND/OR EQUIPMENT IS DAMAGED, THE CONTRACTOR SHALL REPAIR AND/OR REPLACE THE CONDUIT AND/OR EQUIPMENT AT NO COST TO THE CITY OR STATE.
7. THE CONTRACTOR SHALL MAKE SPECIAL NOTE OF THE REQUIREMENT FOR BURIED WARNING TAPE, SPECIFIED AS PART OF "TRENCH AND BACK FILL FOR ELECTRICAL WORK". THE INSTALLATION OF THE TAPE SHALL BE INSPECTED AND APPROVED BY THE RESIDENT ENGINEER PRIOR TO BACKFILLING OR DURING PLOWING OPERATIONS, AS APPLICABLE.
8. THE CONTRACTOR WILL BE RESPONSIBLE FOR THE ESTABLISHMENT OF FINISHED GRADE. THE RESIDENT ENGINEER MAY ASSIST THE CONTRACTOR, AS APPLICABLE, BUT THE RESPONSIBILITY FOR COORDINATING THE FINISHED GRADE ELEVATION WITH THE TOP OF THE FOUNDATION HEIGHTS AND THE LIGHT SHALL REMAIN WITH THE CONTRACTOR.
9. NO POLES SHALL BE ERECTED UNTIL THE RESPECTIVE FOUNDATIONS HAVE CURED, AS APPROVED BY THE ENGINEER.
10. THE CONTRACTOR SHALL MAKE SPECIAL NOTE OF THE REQUIREMENTS FOR WIRE MARKERS AND SHALL TAG ALL WIRE ACCORDINGLY.
11. EQUIPMENT GROUND CONDUCTORS SHALL BE SPLICED AND BONDED AT EACH LIGHT POLE OR OTHER PIECE OF EQUIPMENT.
12. UNDERGROUND SPLICES OF LIGHTING CONDUCTORS WILL NOT BE ALLOWED EXCEPT AT LIGHT POLE BASE.
13. CONDUITS AND UNIT DUCTS MUST BE POSITIONED IN THE FIELD TO AVOID CONFLICT WITH TREE, BUSHES, DRAINS AND OTHER UTILITIES.
14. THE CONTROLLER SHALL BE UL LISTED, NEMA 3R, AND BE SUITABLE FOR USE AS SERVICE ENTRANCE RATED.

NOMINAL WATTAGE	FUSE SIZE
250W COBRAHEAD WITH 70W COACHLIGHT	3.0 AMP

LUMINAIRE FUSE SIZE TABLE

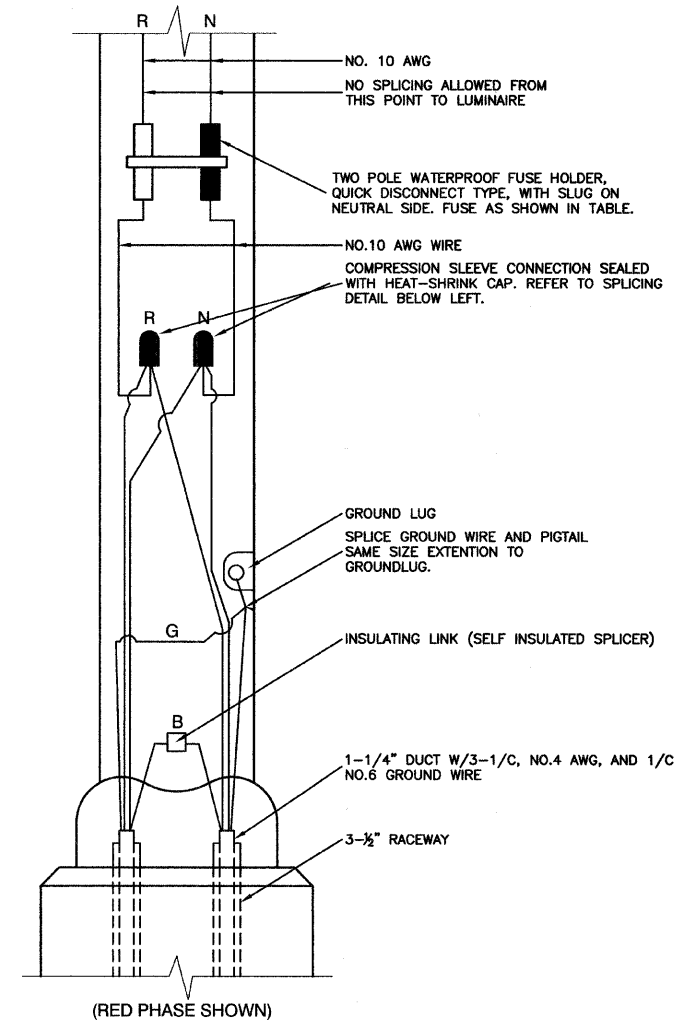

POLE HANDHOLE WIRING DIAGRAM
(TYPICAL FOR SINGLE LUMINAIRE INSTALLATION)

NOTE:
ALLOW 36" LOOP OF CABLES TO INSURE SUFFICIENT SLACK FOR WITHDRAWAL OF THE CONNECTORS OUTSIDE OF THE POLE HANDHOLE.



FILE NAME = 09306-DTLS-01 - P03	USER NAME =	DESIGNED -- PAP	REVISED --	STATE OF ILLINOIS DEPARTMENT OF TRANSPORTATION	BURNHAM AVENUE STREET LIGHTING DETAILS	F.A.U. RTE.	SECTION	COUNTY	TOTAL SHEETS	SHEET NO.	
	PLOT SCALE = N/A	CHECKED -- EJT	REVISED --			2943	09-00033-00-LT	COOK	10	6	
	PLOT DATE = 12-09-09	DRAWN -- MJD	REVISED --			SCALE: N/A	SHEET NO. 6 OF 10 SHEETS	STA. N/A	TO STA. N/A	CONTRACT NO. 63271	
		CHECKED -- DWS	REVISED --			FED. ROAD DIST. NO. 1 ILLINOIS FED. AID PROJECT ARA-9003 (341)					