

SECTION THRU BARREL
(Cast in Place)

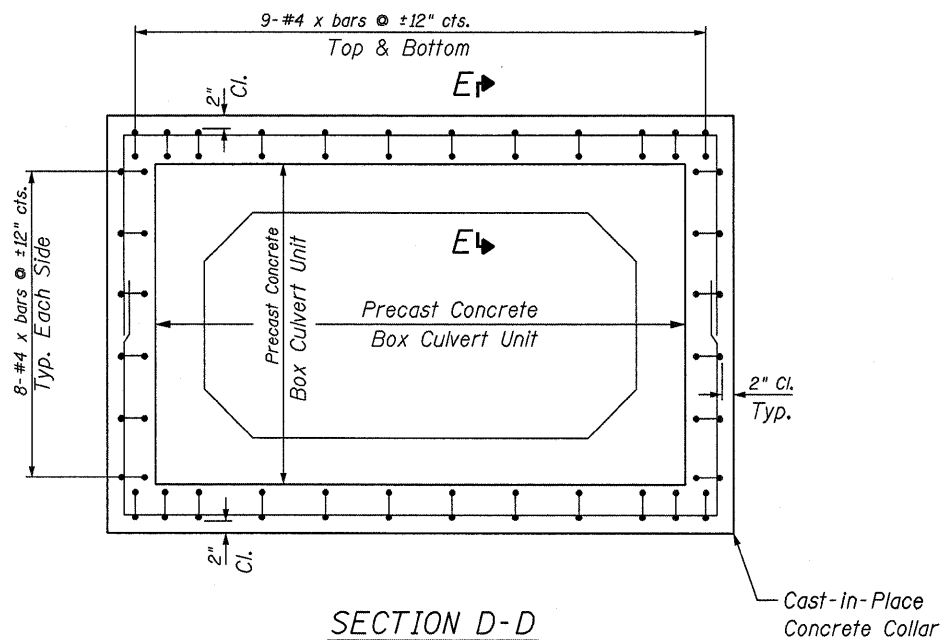

SECTION D-D

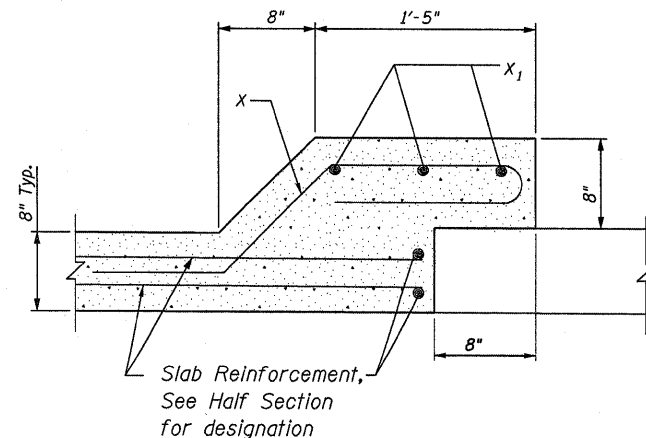

SECTION E-E
Top Slab shown, mirror horizontally for Bottom Slab, Side slabs Sim.

FILE NAME =	USER NAME = duncanbd	DESIGNED -	REVISED -
ca:\pwwork\PIWIDOT\DUNCANBD\dms31838\epc2508-shd-detailed.dgn	2508-shd-detailed.dgn	DRAWN -	REVISED -
PLOT SCALE = 58.0000' / IN.		CHECKED -	REVISED -
PLOT DATE = Dec 08, 2009 - 11:35:15 AM		DATE -	REVISED -

STATE OF ILLINOIS
DEPARTMENT OF TRANSPORTATION

SN 050-2559
CULVERT EXTENSION (RIGHTSIDE)

SCALE: SHEET NO. OF SHEETS STA. TO STA.

F.A.P. RTE.	SECTION	COUNTY	TOTAL SHEETS	SHEET NO.
311	(SIN)	LASALLE	39	21
CONTRACT NO. 66857				
ILLINOIS FED. AID PROJECT				