

STATE OF ILLINOIS
DEPARTMENT OF TRANSPORTATION

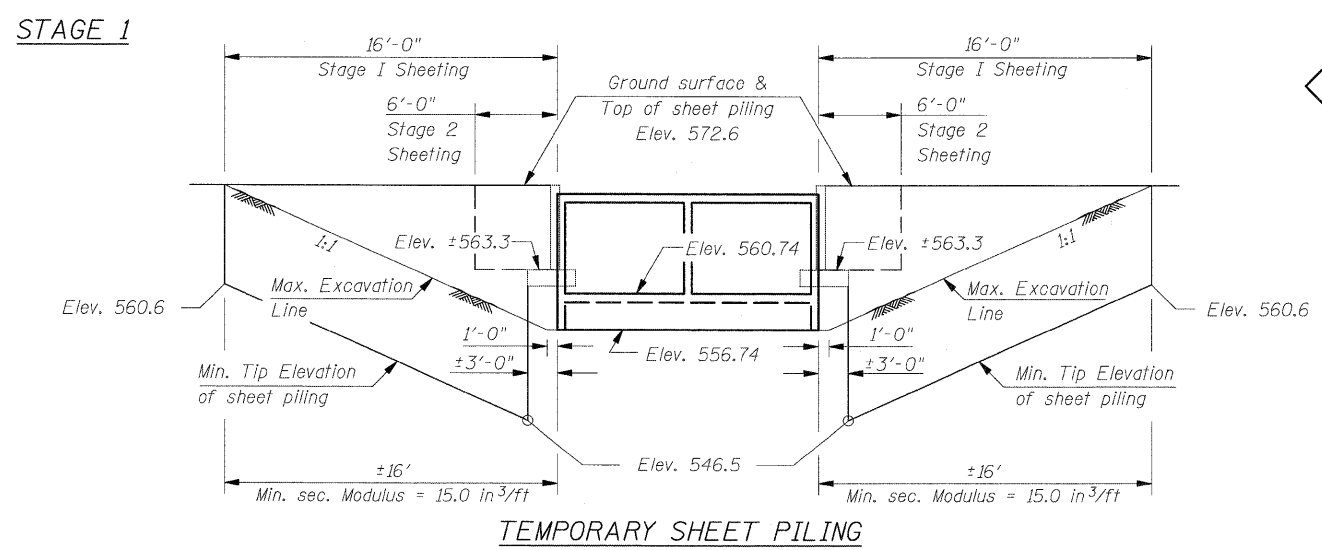
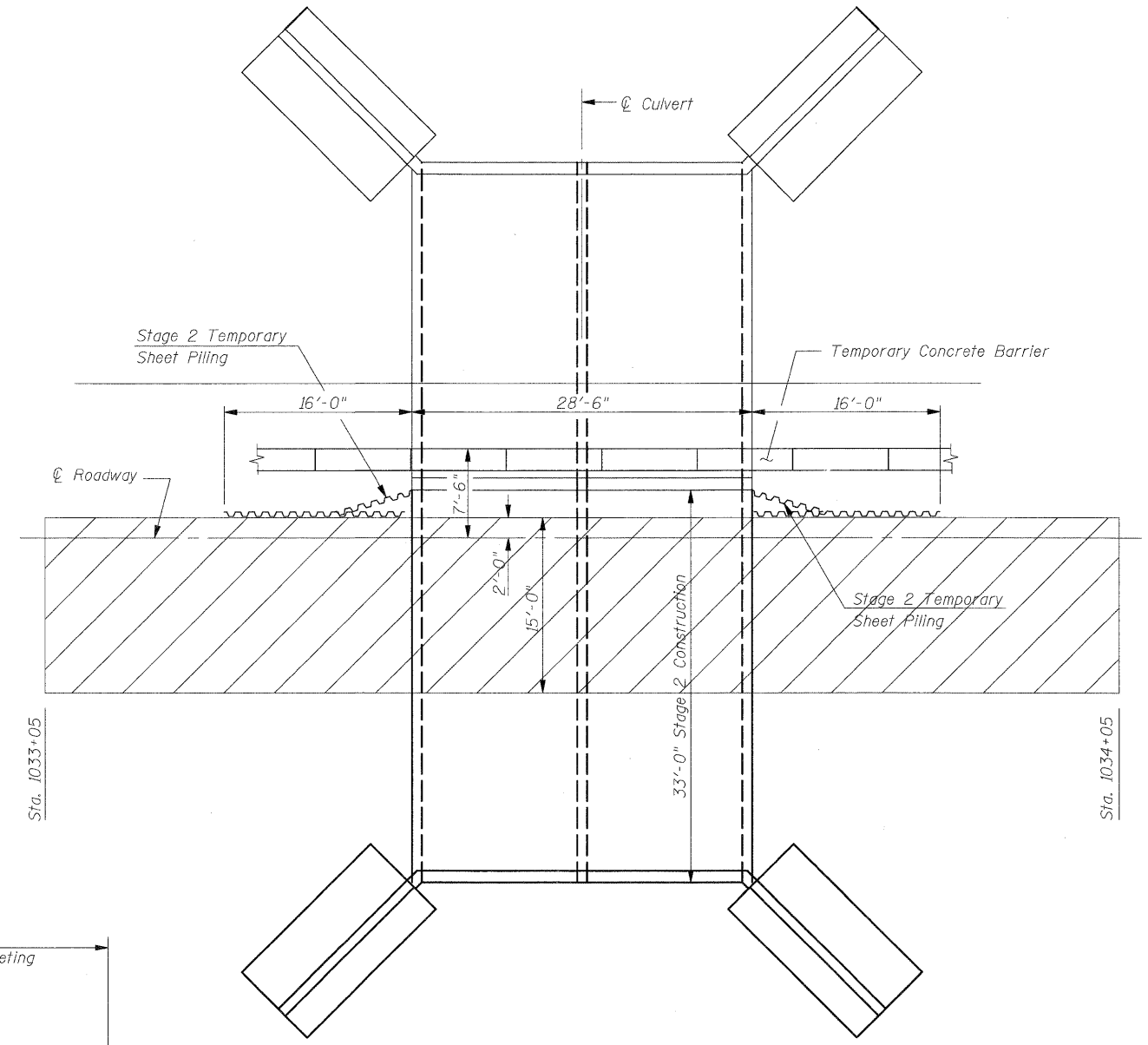
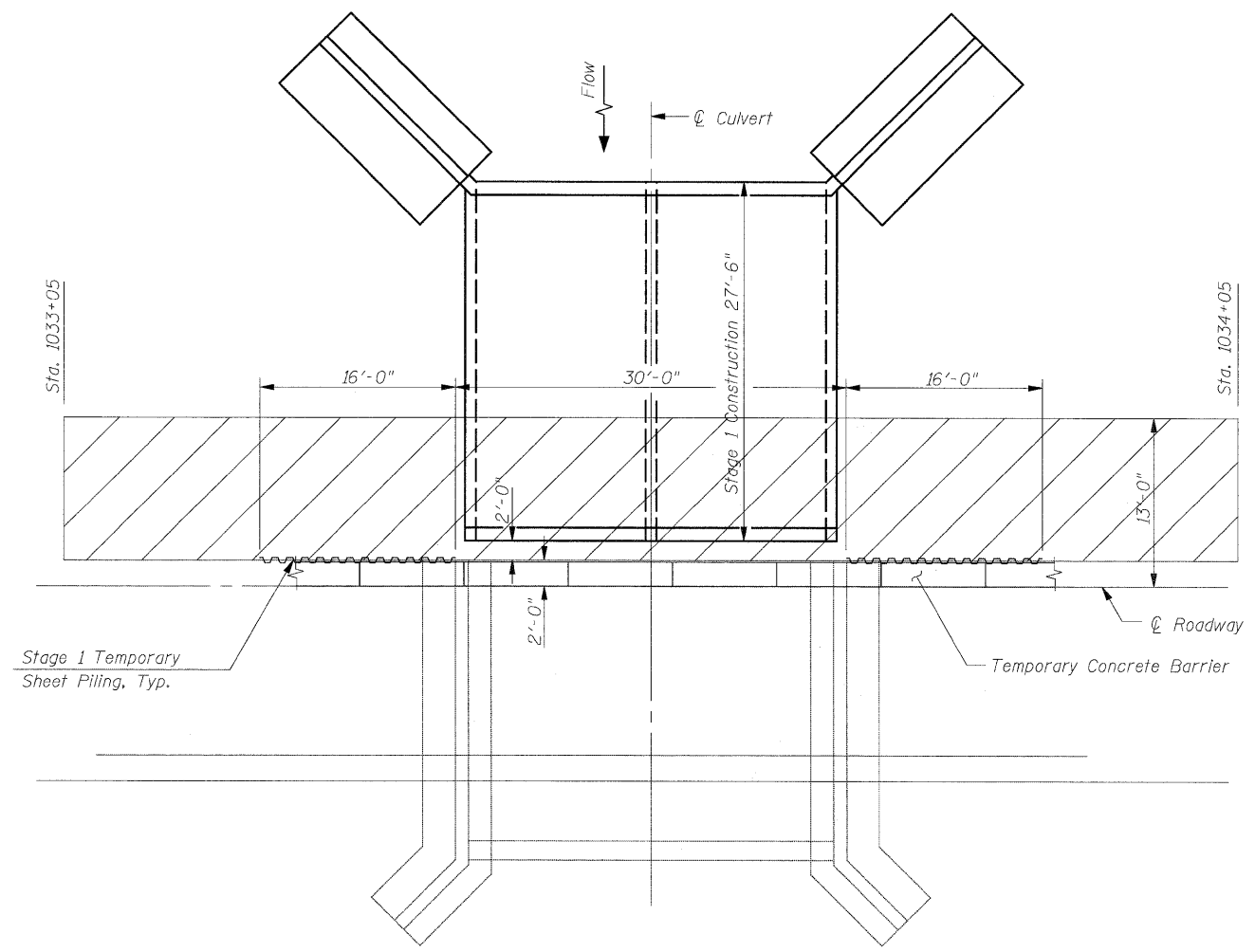

STAGE 2

LEGEND
 - Pavement Removal

**STAGE CONSTRUCTION DETAILS &
TEMPORARY SHEET PILING**
S.N. 026-2019

Notes:
 If the Contractor chooses to alter the temporary cantilevered sheet piling design requirements shown on the plans, a design submittal including plan details and calculations will be required for review and acceptance by the Engineer.
 The Contractor shall connect the first sheet to the existing abutment wall to ensure stability of sheets driven to the top of the existing footing. This connection shall be reviewed and accepted by the Engineer and included in the cost for Temporary Sheet Piling.

DESIGNED	SCD
CHECKED	DRB
DRAWN	THW
CHECKED	SCD

ie consultants
 IE CONSULTANTS, INC
 6420 SOUTH SIXTH STREET
 SPRINGFIELD, ILLINOIS 62712
 TEL: (217) 529-9027
 FAX: (217) 529-4543
 IESPRINGFIELD@IE-CONSULTANTS.COM
 WWW.IE-CONSULTANTS.COM

SHEET NO.	F.A. RTE.	SECTION	COUNTY	TOTAL SHEETS	SHEET NO.
2	*	114B-1(1) & 114B-1(2)	FAYETTE	54	43
OF 9 SHEETS	* F.A.P. RTE. 750, F.A.S. RTE. 719		CONTRACT NO. 74110		
FED. ROAD DIST. NO.		ILLINOIS FED. AID PROJECT			