

STATE OF ILLINOIS
DEPARTMENT OF TRANSPORTATION

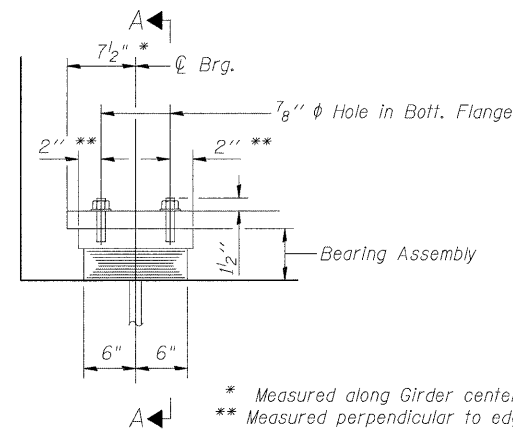

ELEVATION AT ABUT.

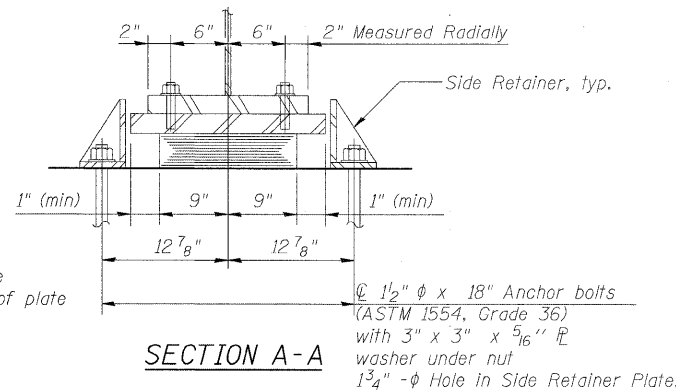

SECTION A-A

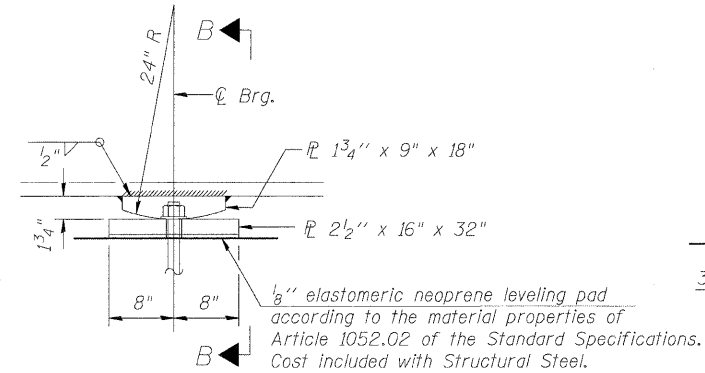

ELEVATION AT PIER

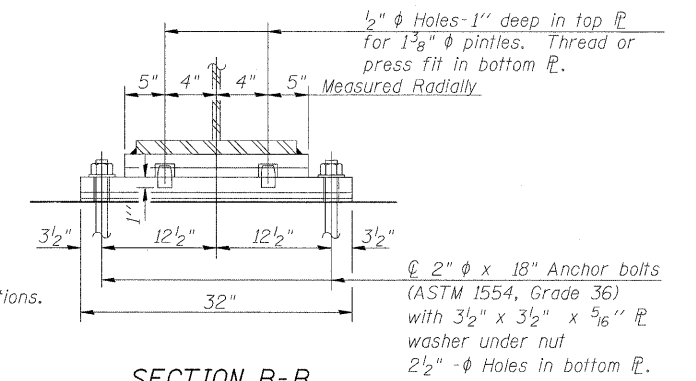

SECTION B-B

TYPE I ELASTOMERIC EXP. BRG.

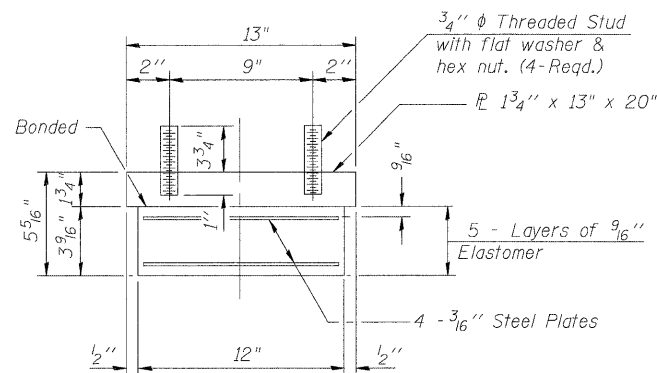

BEARING ASSEMBLY

Note:
Shim plates shall not be placed under Bearing Assembly.

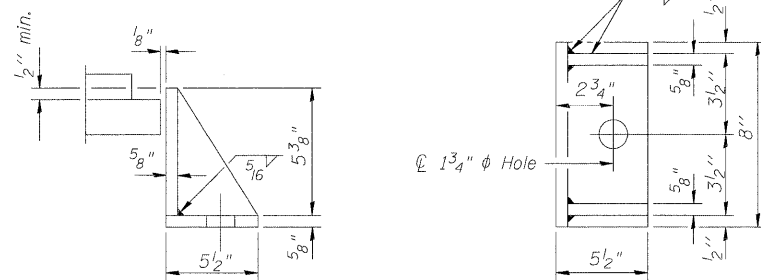

SIDE RETAINER

Equivalent rolled angle with stiffeners will be allowed in lieu of welded plates.

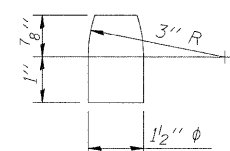

PINTLE

(AASHTO M270 Grade 50)

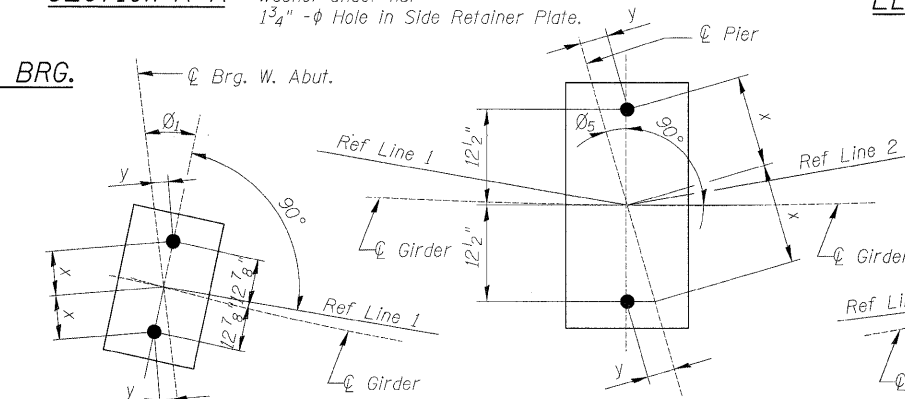

ANCHOR BOLT LAYOUT AT WEST ABUT.

ANCHOR BOLT LAYOUT AT PIER

ANCHOR BOLT LAYOUT AT EAST ABUT.

Beam	θ_1	x	y
1	15°10'45"	12 7/16"	3 3/8"
2	15°01'20"	12 7/16"	3 5/16"
3	14°52'07"	12 7/16"	3 5/16"
4	14°43'05"	12 7/16"	3 1/4"
5	14°35'59"	12 7/16"	3 1/4"
6	14°27'17"	12 7/16"	3 3/8"
7	14°18'45"	12 1/2"	3 3/8"
8	14°10'23"	12 1/2"	3 3/8"

Beam	θ_5	x	y
1	11°35'58"	12 1/4"	2 1/2"
2	11°28'52"	12 1/4"	2 1/2"
3	11°21'55"	12 1/4"	2 7/16"
4	11°15'06"	12 1/4"	2 7/16"
5	11°09'45"	12 1/4"	2 7/16"
6	11°03'11"	12 1/4"	2 3/8"
7	10°56'44"	12 1/4"	2 3/8"
8	10°50'25"	12 1/4"	2 3/8"

Beam	θ_2	x	y
1	8°01'34"	12 3/4"	1 13/16"
2	7°56'40"	12 3/4"	1 3/4"
3	7°51'53"	12 3/4"	1 3/4"
4	7°47'11"	12 3/4"	1 3/4"
5	7°43'29"	12 3/4"	1 3/4"
6	7°38'57"	12 3/4"	1 11/16"
7	7°34'30"	12 3/4"	1 11/16"
8	7°30'09"	12 3/4"	1 11/16"

Notes:
Anchor bolts shall be ASTM F1554 all-thread (or an Engineer-approved alternate material) of the grade(s) and diameter(s) specified. ASTM A307 Grade C anchor bolts may be used in lieu of ASTM F1554 Grade 36 (Fy=36ksi). The corresponding specified grade of AASHTO M314 anchor bolts may be used in lieu of ASTM F1554.
Anchor bolts at fixed bearings may be either cast in place or installed in holes drilled after the supported member is in place.
Anchor bolts for side retainers may be cast in place or installed in holes drilled before or after members are in place.
Drilled and set anchor bolts shall be installed according to Article 521.06 of the Standard Specifications.
Side retainers and other steel members required for the bearing assembly shall be included in the cost of Elastomeric Bearing Assembly, Type I.
The structural steel plates of the Bearing Assembly shall conform to the requirements of AASHTO M 270 Grade 50.
Two 1/8 in. adjusting shims shall be provided for each bearing in addition to all other plates or shims and placed as shown on bearing details.

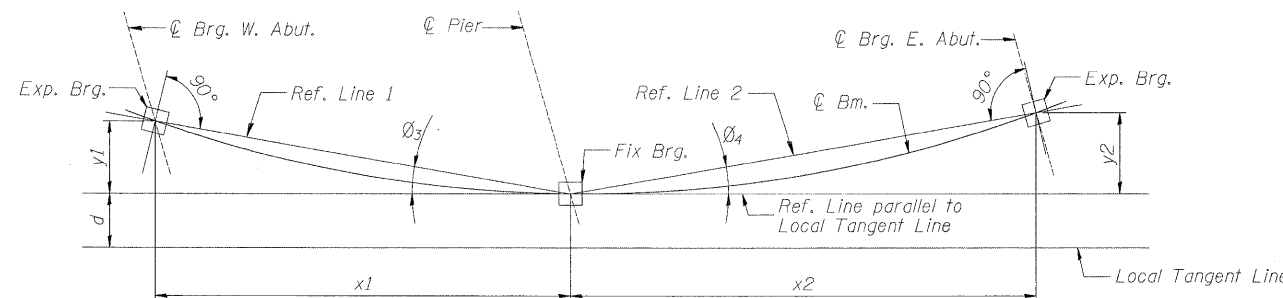

BEARING ORIENTATION

Beam	θ_3	θ_4	x1 (ft.)	y1 (ft.)	x2 (ft.)	y2 (ft.)	d (ft.)
1	3°58'20"	3°10'51"	91.952	6.385	91.863	5.105	51.001
2	3°48'55"	3°15'45"	91.901	6.129	91.837	5.235	43.492
3	3°39'42"	3°20'32"	91.851	5.878	91.812	5.362	35.987
4	3°30'40"	3°25'14"	91.803	5.633	91.787	5.486	28.484
5	3°23'34"	3°28'56"	91.765	5.440	91.768	5.584	22.484
6	3°14'52"	3°33'28"	91.718	5.205	91.744	5.704	14.987
7	3°06'20"	3°37'55"	91.672	4.974	91.721	5.822	7.492
8	2°57'58"	3°42'16"	91.628	4.748	91.698	5.937	0.000

BILL OF MATERIAL

Item	Unit	Total
Elastomeric Bearing Assembly, Type I	Each	16
Anchor Bolts 1 1/2"	Each	32
Anchor Bolts 2"	Each	16

BEARING DETAILS
STRUCTURE NO. 067-0042

DESIGNED - JPM
CHECKED - CCS
DRAWN - JPM
CHECKED - WPM



9-28-09

SHEET NO. 17 34 SHEETS	F.A.P. RTE. 809	SECTION 67-1HBR	COUNTY Monroe	TOTAL SHEETS 144	SHEET NO. 81
	CONTRACT NO. 76977				
FED. ROAD DIST. NO. 7 ILLINOIS FED. AID PROJECT					