

STATE OF ILLINOIS
DEPARTMENT OF TRANSPORTATION

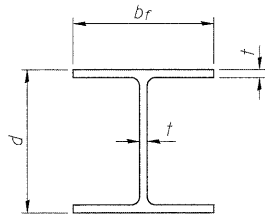

STEEL PILE TABLE

Designation	Depth d	Flange width br	Web and Flange thickness t	Encasement diameter A
HP 14x117	14 1/4"	14 7/8"	13/16"	30"
x102	14"	14 3/4"	11/16"	30"
x89	13 7/8"	14 3/4"	5/8"	30"
x73	13 5/8"	14 5/8"	1/2"	30"
HP 12x84	12 1/4"	12 1/4"	11/16"	24"
x74	12 1/8"	12 1/4"	5/8"	24"
x63	12"	12 1/8"	1/2"	24"
x53	11 3/4"	12"	7/16"	24"
HP 10x57	10"	10 1/4"	9/16"	24"
x42	9 3/4"	10 1/8"	7/16"	24"
HP 8x36	8"	8 1/8"	7/16"	18"

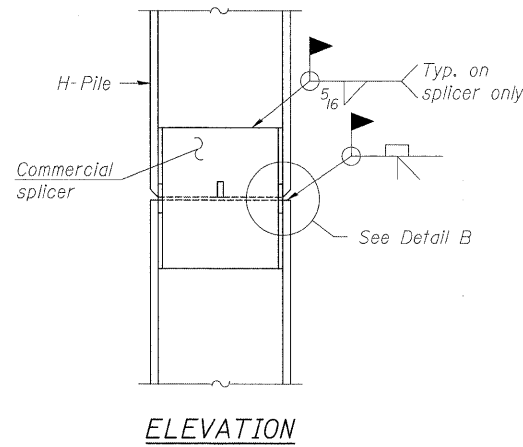

ELEVATION

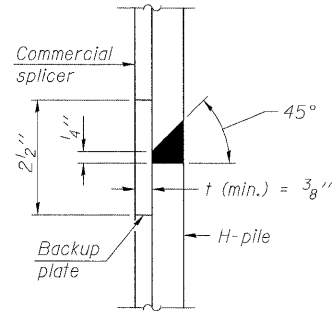

DETAIL "B"

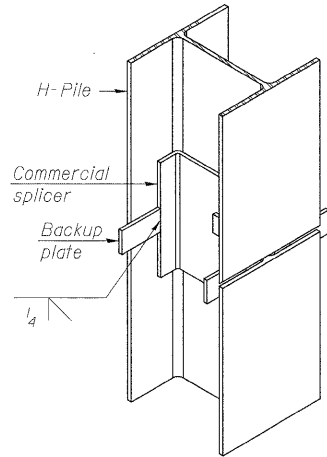

ISOMETRIC VIEW

WELDED COMMERCIAL SPLICE

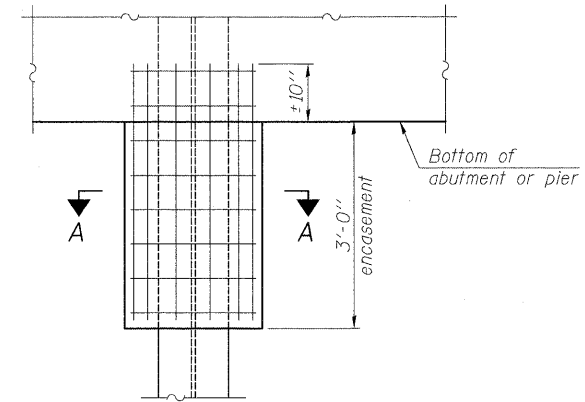

ELEVATION

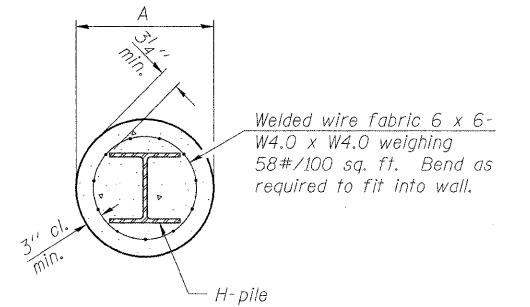

SECTION A-A

Notes:
Forms for encasement may be omitted when soil conditions permit.

PILE ENCASEMENT

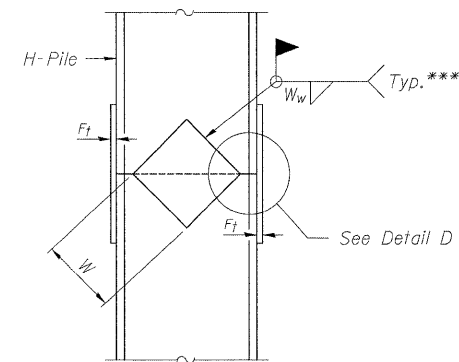

ELEVATION

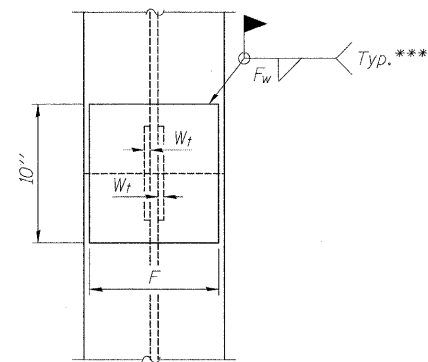

END VIEW

Designation	F	F _t	F _w	W	W _t	W _w
HP 14x117	12 1/2"	1"	7/8"	7 3/4"	5/8"	1/2"
x102	12 1/2"	7/8"	3/4"	7 3/4"	5/8"	1/2"
x89	12 1/2"	3/4"	11/16"	7 3/4"	5/8"	1/2"
x73	12 1/2"	5/8"	9/16"	7 3/4"	5/8"	1/2"
HP 12x84	10"	7/8"	11/16"	6 1/2"	5/8"	1/2"
x74	10"	7/8"	11/16"	6 1/2"	5/8"	1/2"
x63	10"	5/8"	1/2"	6 1/2"	1/2"	3/8"
x53	10"	5/8"	1/2"	6 1/2"	1/2"	3/8"
HP 10x57	8"	3/4"	9/16"	5 1/4"	1/2"	3/8"
x42	8"	5/8"	9/16"	5 1/4"	1/2"	3/8"
HP 8x36	7"	5/8"	7/16"	4 1/4"	1/2"	3/8"

Notes:
The steel H-piles shall be according to AASHTO M270 Grade 50.

WELDED PLATE FIELD SPLICE

STEEL H PILES
STRUCTURE NO. 067-0042

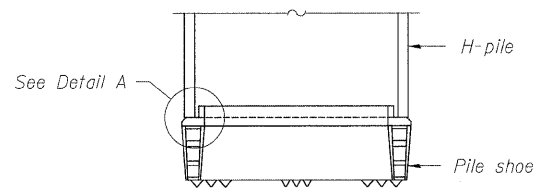

ELEVATION

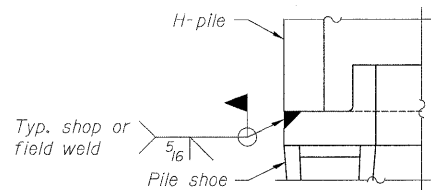

DETAIL A

H-PILE SHOE ATTACHMENT

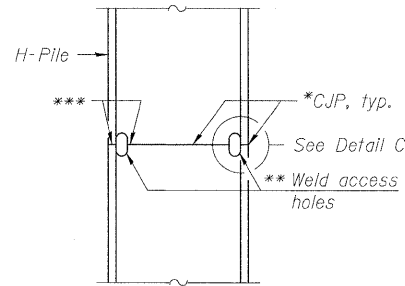

ELEVATION

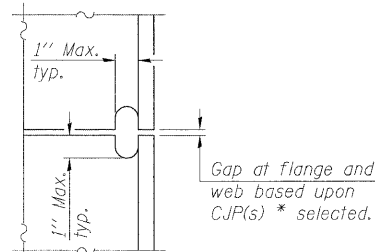

DETAIL C

COMPLETE PENETRATION WELD SPLICE

- * Use joint conforming to Figure 3.4 in AWS D1.1, Structure Welding Code - Steel.
- ** Preparation per Fig. 5.2 in AWS D1.1, Structure Welding Code - Steel.
- *** Interrupt welds 1/4" from end of each pile.

DESIGNED -
CHECKED -
DRAWN - JPM
CHECKED - WPM
9-28-09 F-HP



SHEET NO.26	F.A.P R.T.E.	SECTION	COUNTY	TOTAL SHEETS	SHEET NO.
	809	67-1HBR	Monroe	144	90
34 SHEETS					
CONTRACT NO. 76977					
FED. ROAD DIST. NO. 7 ILLINOIS FED. AID PROJECT					