

F.A. R.T.E.	SECTION	COUNTY	TOTAL SHEETS	SHEET NO.
VAR.	2020-220-1	COOK	9	1
		ILLINOIS	CONTRACT NO. 62M97	

03-05-2021 LETTING ITEM 179

STATE OF ILLINOIS
DEPARTMENT OF TRANSPORTATION

FOR INDEX OF SHEETS, SEE SHEET NO. 2

**PROPOSED
HIGHWAY PLANS**

ROUTE: VARIOUS DISTRICT ONE
SECTION: 2020-220-1
ARTERIAL HIGHWAY CLEANING (SWEEPING)
COUNTY: COOK (NORTH)
C-91-018-21

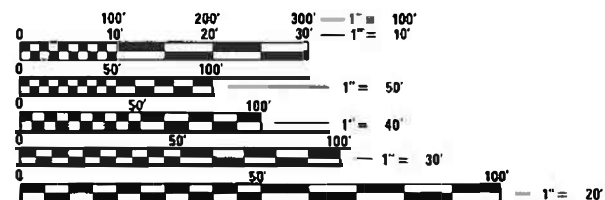
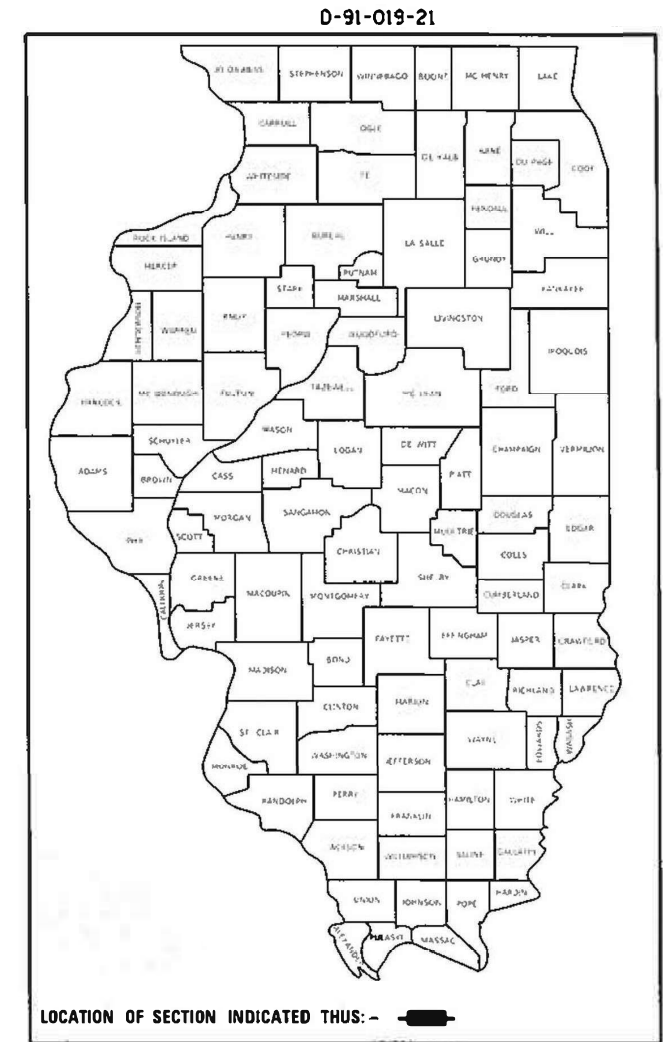

FULL SIZE PLANS HAVE BEEN PREPARED USING STANDARD ENGINEERING SCALES. REDUCED SIZED PLANS WILL NOT CONFORM TO STANDARD SCALES. IN MAKING MEASUREMENTS ON REDUCED PLANS THE ABOVE SCALES MAY BE USED.

J.U.L.I.E.
JOINT UTILITY LOCATION INFORMATION FOR EXCAVATION
1-800-892-0123
OR 811

LOCATION MAPS - SEE INDEX OF SHEETS

PROJECT MANAGER: J. ALAIN MIDY (847) 221-3056

CONTRACT NO. 62M97

STATE OF ILLINOIS
DEPARTMENT OF TRANSPORTATION

SUBMITTED August 24, 2020
[Signature]
REGIONAL ENGINEER

October 2, 2020
[Signature]
ENGINEER OF DESIGN AND ENVIRONMENT

October 2, 2020
[Signature]
DIRECTOR OF HIGHWAYS PROJECT IMPLEMENTATION

PRINTED BY THE AUTHORITY
OF THE STATE OF ILLINOIS

F.A. RTE.	SECTION	COUNTY	TOTAL SHEETS	SHEET NO.
VAR.	2020-220-I	COOK	9	2
STA.		TO STA.		
FED. ROAD DIST. NO.	ILLINOIS	FED. AID PROJECT		

INDEX OF SHEETS

1. TITLE SHEET
2. INDEX OF SHEETS
APPLICABLE STATE STANDARDS
3. SUMMARY OF QUANTITIES
SCHEDULE OF CLEANING STARTING DATES
4. ARTERIAL TYPICAL SECTIONS
5. ARTERIAL CLEANING: COOK COUNTY
ARLINGTON HEIGHTS TEAM SECTION
6. ARTERIAL CLEANING: COOK COUNTY
NORTHBROOK TEAM SECTION
7. ARTERIAL CLEANING: COOK COUNTY
NORTHSIDE TEAM SECTION
8. ARTERIAL CLEANING: COOK COUNTY
RODENBURG TEAM SECTION
9. TRAFFIC CONTROL AND PROTECTION FOR SIDE ROADS,
INTERSECTIONS AND DRIVEWAYS (TC-10)

STATE STANDARDS

- | | |
|-----------|------------------------------------------------------------------------------|
| 701001-02 | OFF-ROAD OPERATION 2L, 2W, 15' MIN. AWAY FOR SPEEDS > 45 MPH |
| 701006-05 | OFF-ROAD OPERATION 2L, 2W, 15' TO PAVEMENT EDGE FOR SPEEDS > 45 MPH |
| 701011-04 | OFF-ROAD MOVING OPERATION 2L, 2W, DAY ONLY |
| 701301-04 | LANE CLOSURE, 2L 2W, SHORT TIME OPERATIONS |
| 701311-03 | LANE CLOSURE, 2L 2W, MOVING OPERATIONS - DAY ONLY |
| 701411-09 | LANE CLOSURE, MULTILANE AT ENTERANCE/EXIT RAMP FOR SPEEDS > 45 MPH |
| 701426-09 | LANE CLOSURE, MULTILANE INTERMITTENT OR MOVING OPERATION FOR SPEEDS > 45 MPH |
| 701427-05 | LANE CLOSURE, MULTILANE, INTERMITTENT OR MOVING OPERATIONS ≤ 40 MPH |
| 701901-08 | TRAFFIC CONTROL DEVICES |

PLOT DATE = 8/26/2020
 FILE NAME = p:\planning\commod\illinois\gov\p\1001\Documents\1001\Office\District\1\Projects\Sweeping\Contracta\CAD\Bata\Design\Sweeping\Contracta\2017.dgn
 PLOT SCALE = 1/8"=1'-0"
 USER NAME = mcljup

REV-SEP

REVISIONS		ILLINOIS DEPARTMENT OF TRANSPORTATION
NAME	DATE	
		INDEX OF SHEETS AND STATE STANDARDS
SCALE:	VERT. / HORIZ.	DRAWN BY
DATE		CHECKED BY

F.A. RTE.	SECTION	COUNTY	TOTAL SHEETS	SHEET NO.
VAR.	2020-220-1	COOK	9	4
STA.		TO STA.		
FED. ROAD DIST. NO.	ILLINOIS	FED. AID PROJECT		

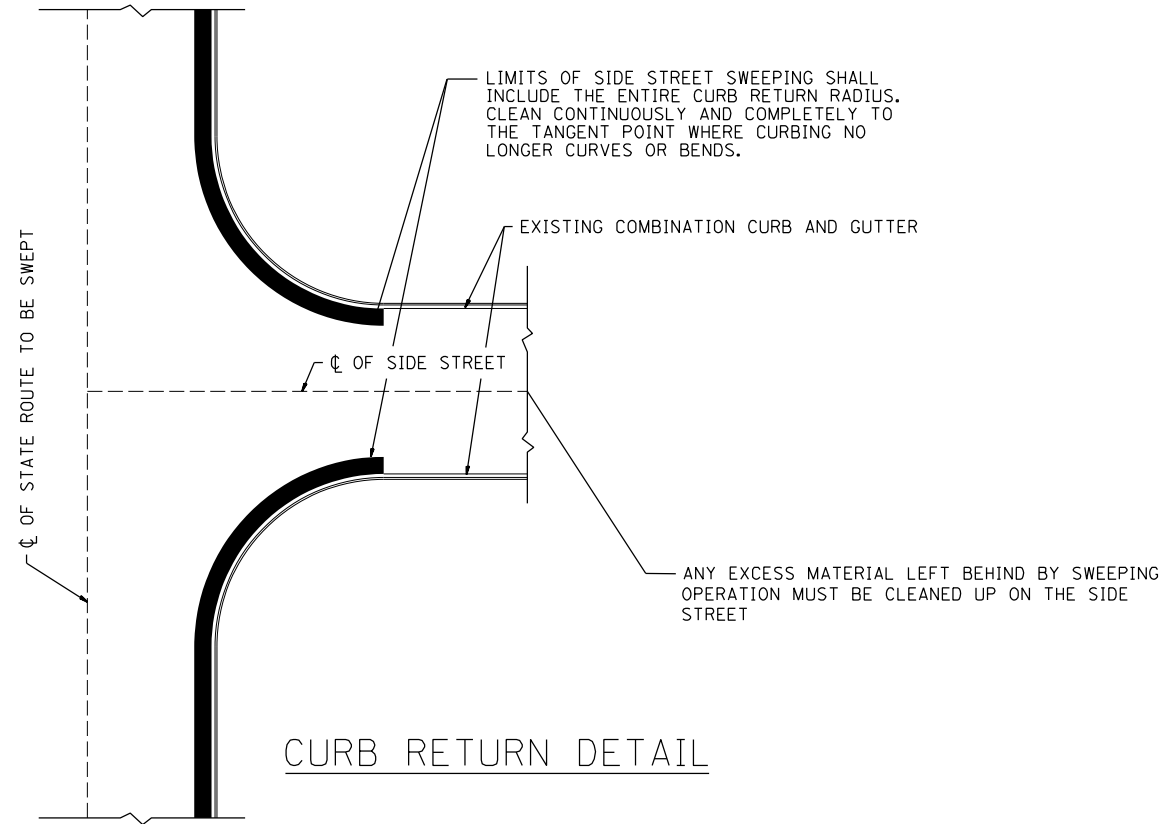

CURB RETURN DETAIL

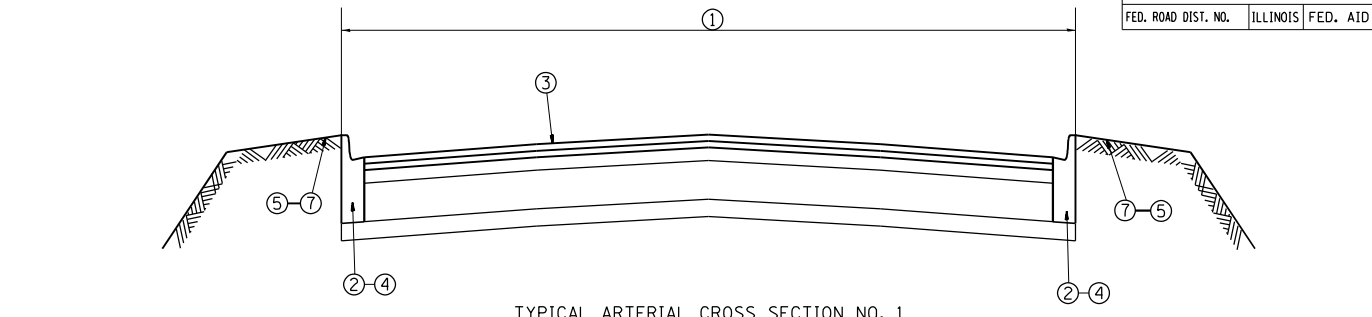

TYPICAL ARTERIAL CROSS SECTION NO. 1

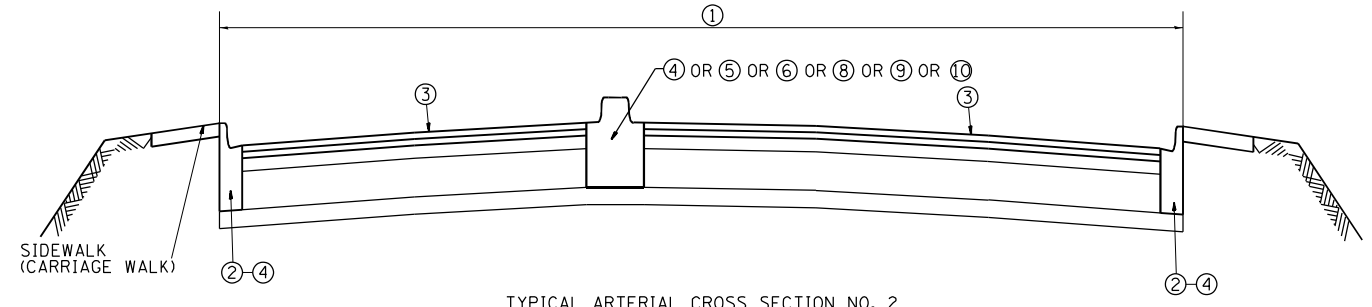

TYPICAL ARTERIAL CROSS SECTION NO. 2

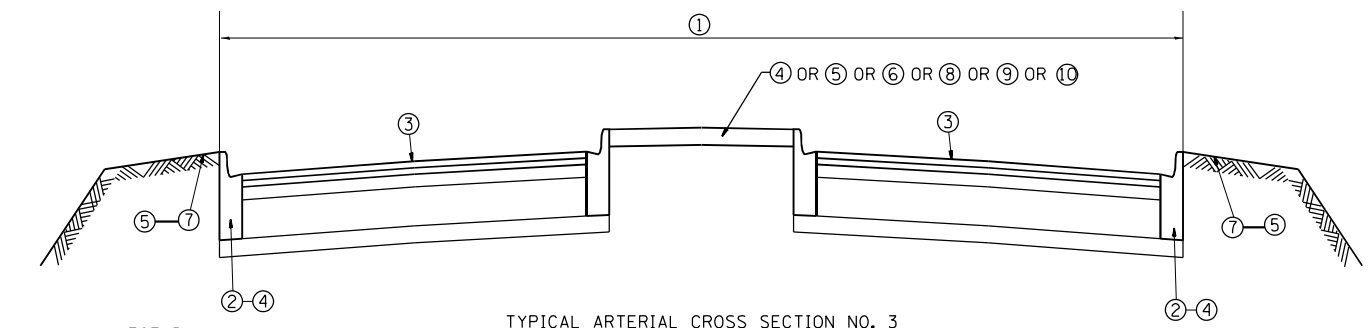

TYPICAL ARTERIAL CROSS SECTION NO. 3

LEGEND

- ① AREA OF ROADWAY CLEANING AND RUBBISH REMOVAL
- ② CURB AND GUTTER
- ③ TRAVELED ROADWAY
- ④ STABILIZED SHOULDER OR MEDIAN
- ⑤ STEEL PLATE GUARDRAIL (SEE NOTE 1)
- ⑥ CONCRETE BARRIER
- ⑦ NON STABILIZED AREA
- ⑧ RAISED CONCRETE MEDIAN
- ⑨ ALL EXISTING TURF MEDIANS
- ⑩ LITTER PICKING

NOTES:

- 1) ALL LOCATIONS OF MEDIANS AND GUARDRAILS SHALL BE CLEANED OF ALL DEBRIS AND RUBBISH INCLUDING BUT NOT LIMITED TO DIRT, WEEDS, SAND, ROCKS, GRAVEL, CONCRETE, WOOD, LIMBS, LEAVES, GARBAGE & ANIMAL CARCASSES BY HAND LABORING UNDERNEATH AND 10 FEET BEHIND GUARDRAIL INCLUDING STABILIZED AND NON STABILIZED AREAS. THIS WORK SHALL BE CONSIDERED AS INCLUDED IN THE CONTRACT UNIT PRICE FOR ALL FULL CLEANING CYCLES.
- 2) SLOPE WALLS UNDER BRIDGES ARE NOT INCLUDED IN AREAS TO BE CLEANED.
- 3) ALL ARTERIAL INTERCHANGES, INTERSECTIONS, RAMPS AND CROSSOVERS SHALL BE CLEANED AND LITTER PICKED.
- 4) ALL PAVED DITCHES AND SPILLWAYS WITHIN 10' OF STABILIZED BASE SHALL BE CLEANED

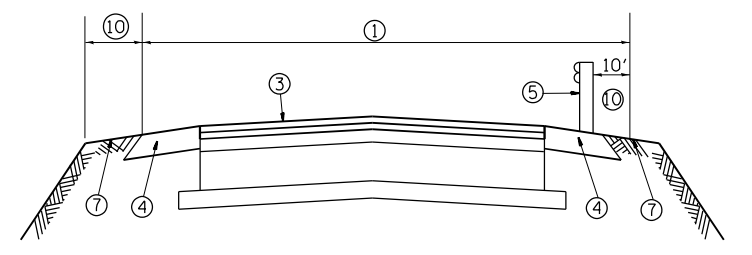

TYPICAL ARTERIAL CROSS SECTION NO. 4

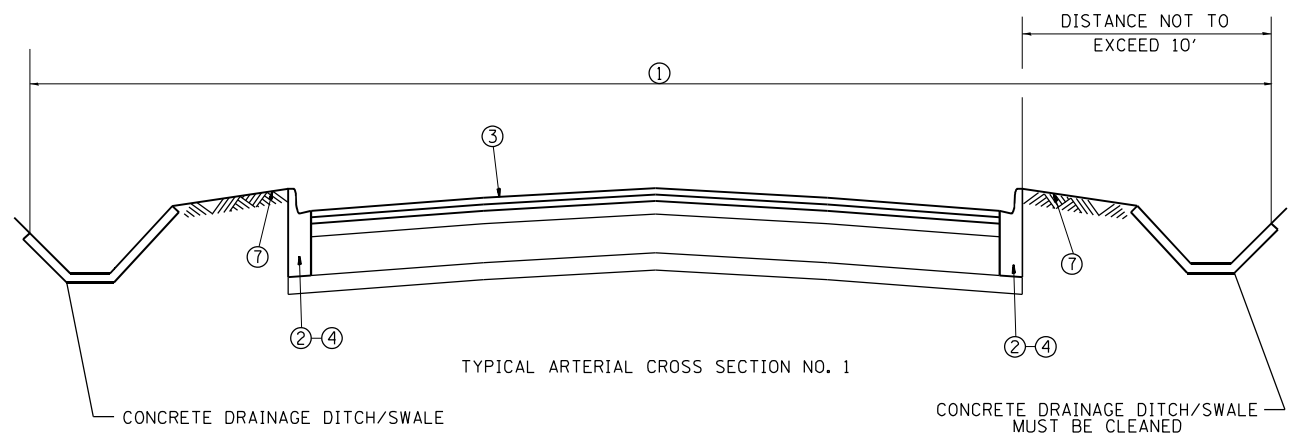

TYPICAL ARTERIAL CROSS SECTION NO. 1

PLOT DATE = 8/28/2020
 FILE NAME = p:\v\p\enr\com\do\illinois\go\p\m\1001\Documents\1001_Offices\District_1\Projects\Sweeping_Contracts\CAD\Drawings\SweepingContract2017.dgn
 PLOT SCALE = 1/8" = 1'-0"
 USER NAME = mchup

REVISIONS	
NAME	DATE

ILLINOIS DEPARTMENT OF TRANSPORTATION
 EXPRESSWAY AND ARTERIAL HIGHWAY
 CLEANING (SWEEPING)
**TYPICAL
 ARTERIAL CROSS SECTIONS
 AND CURB RETURN DETAIL**
 SCALE: VERT. _____
 HORIZ. _____
 DATE _____ DRAWN BY _____
 CHECKED BY _____

F.A. RTE.	SECTION	COUNTY	TOTAL SHEETS	SHEET NO.
VAR.	2020-220-1	COOK	9	5
STA.		TO STA.		
FED. ROAD DIST. NO.	ILLINOIS	FED. AID PROJECT		



TEAM SECTION
ARLINGTON HTS.

KEY LOCATIONS
AH1-AH21

NOTE:
KEY LOCATION *AH21 INCLUDES IL 53 FRONTAGE RDS.
AS DEFINED IN THE SPECIAL PROVISIONS

- DISTRICT NO. 1
- STATE HIGHWAYS & EXPRESSWAYS WITHIN STATE JURISDICTION (EXCEPT TOLLWAYS)
 - STATE HIGHWAYS & EXPRESSWAYS TO BE CLEANED
 - - - FUTURE HIGHWAYS
 - VARIOUS AGENCIES HIGHWAYS

REVISIONS	
NAME	DATE

ILLINOIS DEPARTMENT OF TRANSPORTATION

ARTERIAL CLEANING
LOCATION MAP
COOK COUNTY
ARLINGTON HTS TEAM SECTION

SCALE: VERT. / HORIZ.

DATE

DRAWN BY / CHECKED BY

PLOT DATE = 8/26/2020
 FILE NAME = p:\proj\arlene\com\do\illinois\gou\p\m\001\Documents\ID01 Offices\District 1\Projects\Sweeping Contracts\GeoData\Design\SweepingContract2017.dgn
 PLOT SCALE = 1/8" = 100'
 USER NAME = midup

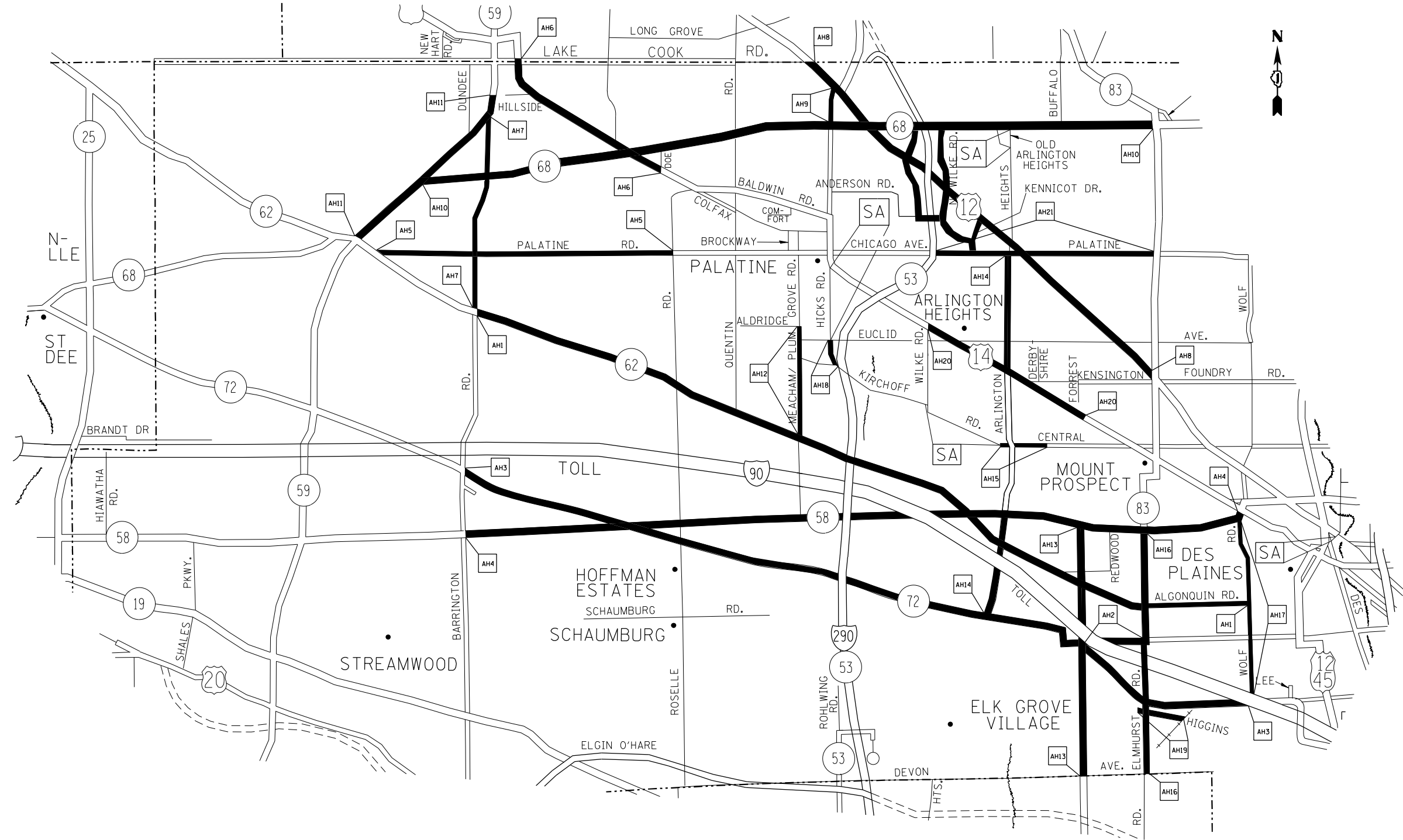

F.A. RTE.	SECTION	COUNTY	TOTAL SHEETS	SHEET NO.
VAR.	2020-220-1	COOK	9	7
STA.		TO STA.		
FED. ROAD DIST. NO.	ILLINOIS	FED. AID PROJECT		

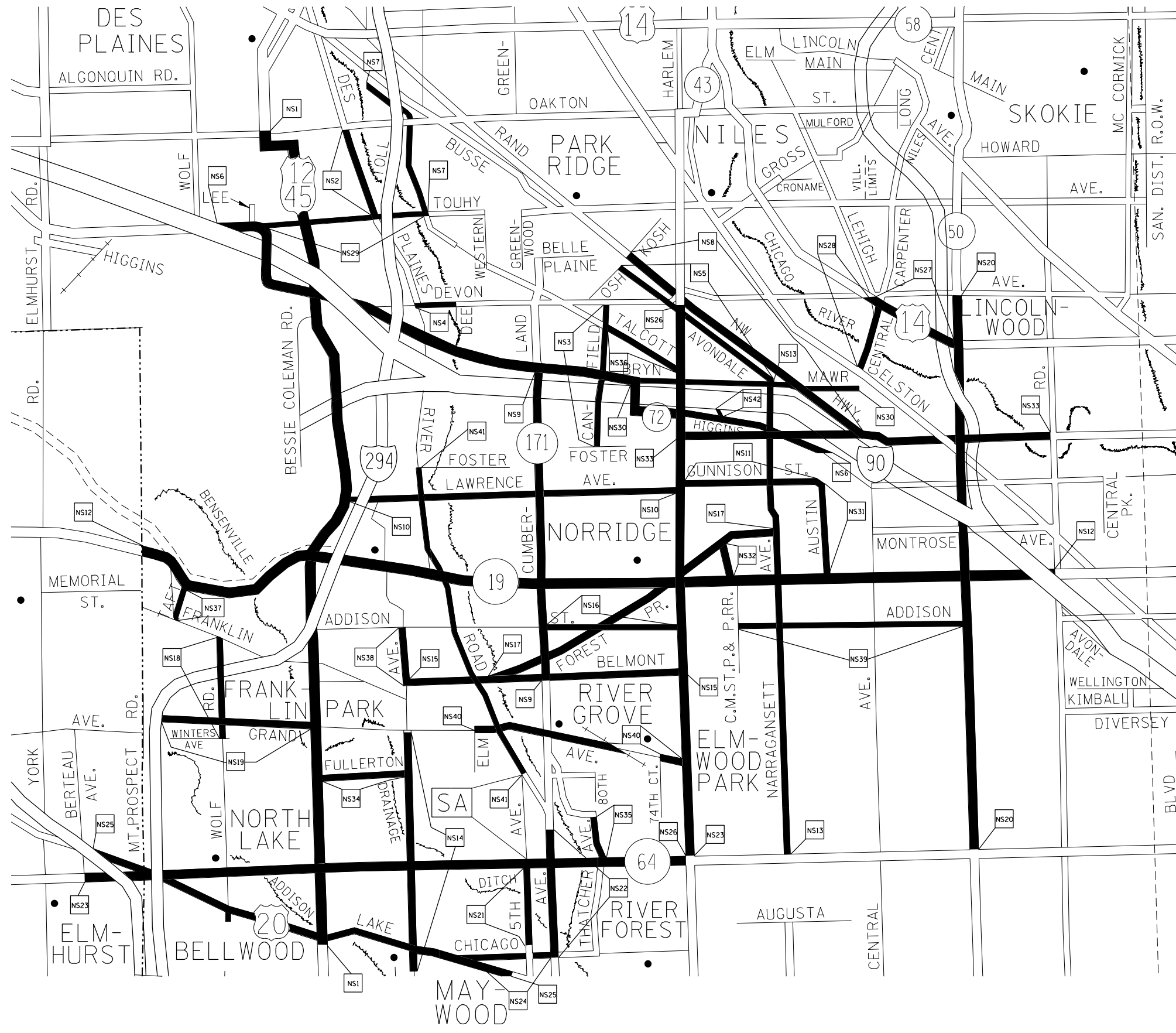

TEAM SECTION
NORTHSIDE

KEY LOCATIONS
NS1-NS42

- DISTRICT NO. 1
- STATE HIGHWAYS & EXPRESSWAYS WITHIN STATE JURISDICTION (EXCEPT TOLLWAYS)
 - STATE HIGHWAYS & EXPRESSWAYS TO BE CLEANED
 - FUTURE HIGHWAYS
 - VARIOUS AGENCIES HIGHWAYS

REVISIONS	
NAME	DATE

ILLINOIS DEPARTMENT OF TRANSPORTATION

ARTERIAL CLEANING
LOCATION MAP
COOK COUNTY NORTH
NORTHSIDE TEAM SECTION

SCALE: VERT. / HORIZ.
DATE

DRAWN BY / CHECKED BY

PLOT DATE = 8/26/2020
 FILE NAME = p:\n\l\ar\com\do\illinois\gov\p\m\1001\Documents\1001\0ffices\District\1\Projects\Sweeping\Contract\62M97\Design\SweepingContract2017.dgn
 PLOT SCALE = 1/8" = 100'
 USER NAME = midup

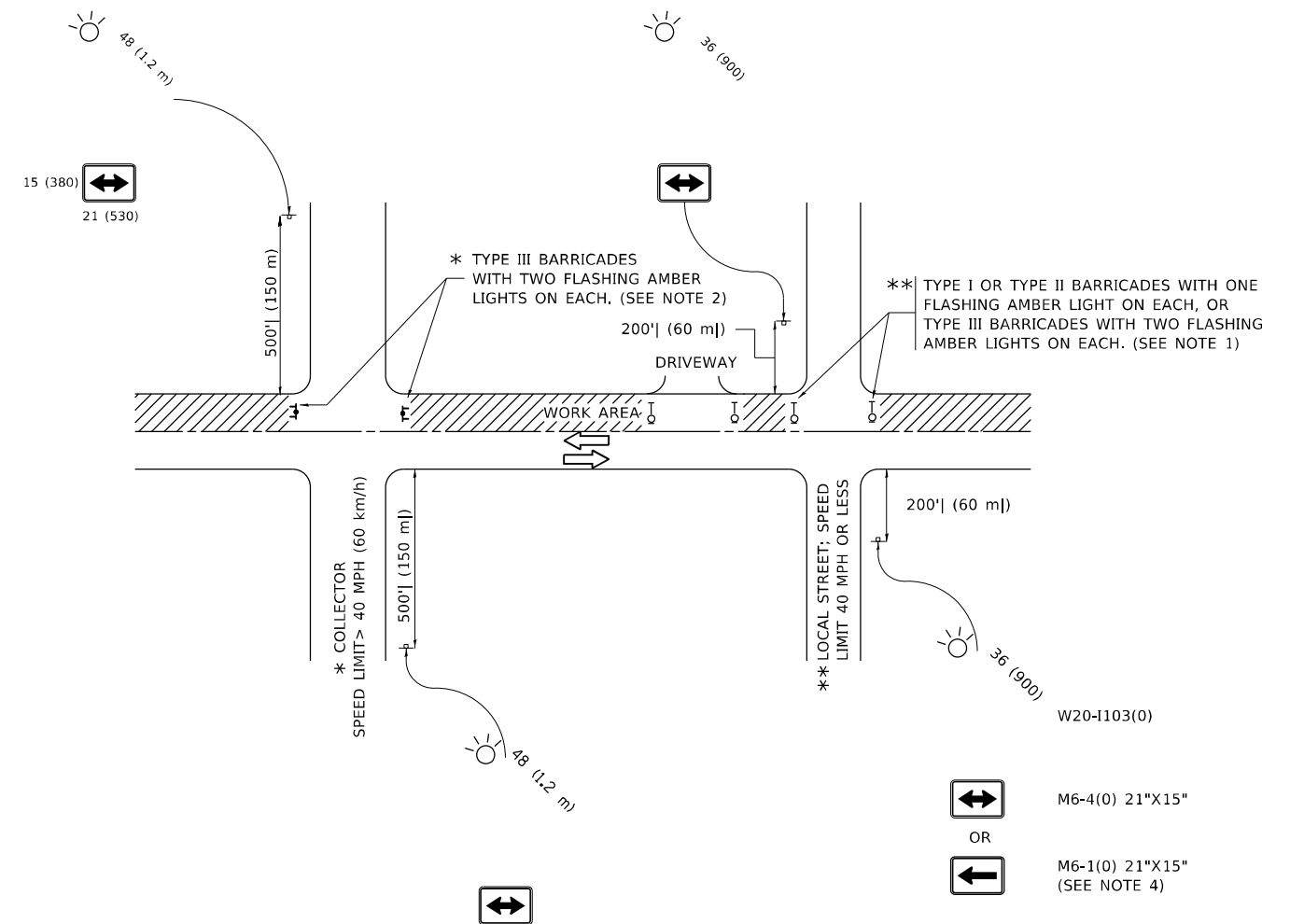

NOTES:

- SIDE ROAD WITH A SPEED LIMIT OF 40 MPH (60 km/h) OR LESS AS SHOWN ON THE DRAWING AND AS DIRECTED BY THE ENGINEER:
 - ONE "ROAD CONSTRUCTION AHEAD" SIGN 36 x 36 (900x900) WITH A FLASHER MOUNTED ON IT APPROXIMATELY 200' (60 m) IN ADVANCE OF THE MAIN ROUTE.
 - THE CLOSED PORTION OF THE MAIN ROUTE SHALL BE PROTECTED BY BLOCKING WITH TYPE I, TYPE II OR TYPE III BARRICADES, 1/3 OF THE CROSS SECTION OF THE CLOSED PORTION.
- SIDE ROAD WITH A SPEED LIMIT GREATER THAN 40 MPH (60 km/h) AS SHOWN ON THE DRAWING AND AS DIRECTED BY THE ENGINEER:
 - ONE "ROAD CONSTRUCTION AHEAD" SIGN 48 x 48 (1.2 m x 1.2 m) WITH A FLASHER MOUNTED ON IT APPROXIMATELY 500' (150 m) IN ADVANCE OF THE MAIN ROUTE.
 - THE CLOSED PORTION OF THE MAIN ROUTE SHALL BE PROTECTED BY BLOCKING WITH TYPE III BARRICADES, 1/2 OF THE CROSS SECTION OF THE CLOSED PORTION.
- CONES MAY BE SUBSTITUTED FOR BARRICADES OR DRUMS AT HALF THE SPACING DURING DAY OPERATIONS. CONES SHALL BE A MINIMUM OF 28 (710) IN HEIGHT.
- WHEN THE SIDE ROAD LIES BETWEEN THE BEGINNING OF THE MAINLINE SIGNING AND THE WORK ZONE, A SINGLE HEADED ARROW (M6-1) SHALL BE USED IN LIEU OF THE DOUBLE HEADED ARROW (M6-4).
- WHEN WORK IS BEING PERFORMED ON A SIDE ROAD OR DRIVEWAY, FOLLOW THE APPLICABLE STANDARD(S). THE DIRECTIONAL ARROW (M6-1 OR M6-4) SHALL BE COVERED OR REMOVED WHEN NO LONGER CONSISTENT WITH THE TRAFFIC CONTROL SET-UP.
- ADVANCE WARNING SIGNS ARE TO BE OMITTED ON DRIVEWAYS UNLESS OTHERWISE SPECIFIED IN THE PLANS OR BY THE ENGINEER.
- THE TRAFFIC CONTROL AND PROTECTION FOR SIDE ROADS, INTERSECTIONS, AND DRIVEWAYS SHALL BE INCLUDED IN THE COST OF SPECIFIED TRAFFIC CONTROL STANDARDS OR ITEMS.

All dimensions are in inches (millimeters) unless otherwise shown.

MODEL: Default
 FILE NAME: p:\m\m\room.dwg
 PROJECT: SWEEPING CONTRACTS\CAD\DATA\DATA\SweepingContract2017.dwg

USER NAME = mldyja	DESIGNED - L.H.A.	REVISED - A. HOUSEH 10-15-96
PLOT SCALE = 100,0000' / in.	CHECKED -	REVISED - T. RAMMACHER 01-06-00
PLOT DATE = 8/26/2020	DATE - 06-89	REVISED - A. SCHUETZE 07-01-13
		REVISED - A. SCHUETZE 09-15-16

**STATE OF ILLINOIS
DEPARTMENT OF TRANSPORTATION**

**TRAFFIC CONTROL AND PROTECTION FOR
SIDE ROADS, INTERSECTIONS, AND DRIVEWAYS**

SCALE: NONE SHEET 1 OF 1 SHEETS STA. TO STA.

F.A. RTE.	SECTION	COUNTY	TOTAL SHEETS	SHEET NO.
	2020-220-I	COOK	9	9
TC-10			CONTRACT NO. 62M97	
ILLINOIS FED. AID PROJECT				