

PLAN	DATE
BY	
SURVEYED	CHECKED
ALIGNMENT	FILE NAME
NO.	

PROFILE	DATE
BY	
SURVEYED	CHECKED
GRADES	NOTES
NO.	

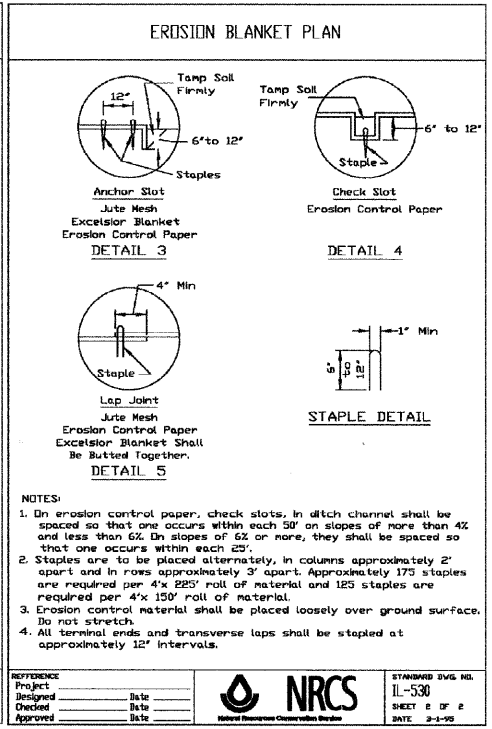
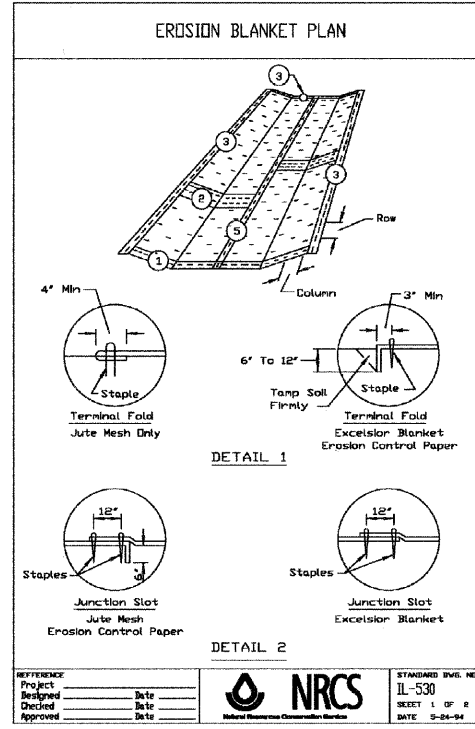

NOTES:

- On erosion control paper, check slots, in ditch channel shall be spaced so that one occurs within each 50' on slopes of more than 4% and less than 6%. On slopes of 6% or more, they shall be spaced so that one occurs within each 25'.
- Staples are to be placed alternately, in columns approximately 2' apart and in rows approximately 3' apart. Approximately 175 staples are required per 4' x 150' roll of material and 125 staples are required per 4' x 150' roll of material.
- Erosion control material shall be placed loosely over ground surface. Do not stretch.
- All terminal ends and transverse laps shall be stapled at approximately 12" intervals.

REFERENCE	Project	IL-530
Designed	Date	
Checked	Date	
Approved	Date	

REFERENCE	Project	IL-530
Designed	Date	
Checked	Date	
Approved	Date	

EROSION CONTROL NOTES:

- EROSION CONTROL MEASURES SHALL MEET ALL REQUIREMENTS OF THE VILLAGE AND THE ENVIRONMENTAL PROTECTION AGENCY, N.P.D.E.S. PERMIT CONSTRUCTION SITE ACTIVITIES.
- UNLESS OTHERWISE INDICATED, ALL VEGETATIVE AND STRUCTURAL EROSION AND SEDIMENT CONTROL PRACTICES WILL BE CONSTRUCTED ACCORDING TO MINIMUM STANDARDS AND SPECIFICATIONS IN THE ILLINOIS URBAN MANUAL REVISED FEBRUARY 2002.
- THE KANE-DUPAGE SOIL AND WATER CONSERVATION DISTRICT (KDSWCD) MUST BE NOTIFIED ONE WEEK PRIOR TO THE PRE-CONSTRUCTION CONFERENCE, ONE WEEK PRIOR TO THE COMMENCEMENT OF LAND DISTURBING ACTIVITIES, AND ONE WEEK PRIOR TO THE FINAL INSPECTION.
- A COPY OF THE APPROVED EROSION AND SEDIMENT CONTROL PLAN SHALL BE MAINTAINED ON THE SITE AT ALL TIMES.
- PRIOR TO COMMENCING LAND-DISTURBING ACTIVITIES IN AREAS OTHER THAN INDICATED ON THESE PLANS (INCLUDING BUT NOT LIMITED TO OFF-SITE BORROW OR WASTE AREAS) A SUPPLEMENTARY EROSION CONTROL PLAN SHALL BE SUBMITTED TO THE OWNER FOR REVIEW BY THE KDSWCD.
- THE CONTRACTOR IS RESPONSIBLE FOR INSTALLATION OF ANY ADDITIONAL EROSION CONTROL MEASURES NECESSARY TO PREVENT EROSION AND SEDIMENTATION AS DETERMINED BY THE KDSWCD.
- DURING DEWATERING OPERATIONS, WATER WILL BE PUMPED INTO SEDIMENT BASINS OR SILT TRAPS. DEWATERING DIRECTLY INTO FIELD TILES OR STORM WATER STRUCTURES IS PROHIBITED.
- IN AREAS WHERE WORK IS COMPLETE, PERMANENT STABILIZATION SHALL OCCUR WITHIN 7 DAYS OF COMPLETION, AND IN AREAS WHERE WORK HAS TEMPORARILY CEASED FOR 21 DAYS OR MORE, TEMPORARY STABILIZATION SHALL OCCUR BY THE 14TH DAY AFTER WORK HAS CEASED. TEMPORARY SEEDING SHALL BE IDOT CLASS I & PERMANENT SEEDING SHALL BE IDOT CLASS I.
- STOCKPILE OF SOIL & OTHER BUILDING MATERIALS TO REMAIN IN PLACE MORE THAN 3 DAYS SHALL BE FURNISHED EROSION & SEDIMENT CONTROL MEASURES (I.E. PERIMETER SILT FENCE), STOCKPILES TO REMAIN IN PLACE FOR 30 DAYS OR MORE SHALL RECEIVE TEMPORARY SEEDING.
- PROPERTIES ADJACENT TO SITE OF A LAND DISTURBANCE SHOULD BE PROTECTED FROM SEDIMENT DEPOSITION. THIS MAY BE ACCOMPLISHED BY PERIMETER CONTROLS SUCH AS FILTER FENCE OR DIKES, OR OTHER APPROVED MEASURES.
- EROSION CONTROL MEASURES MUST BE CONSTRUCTED AS A FIRST STEP IN GRADING AND BE MADE FUNCTIONAL BEFORE UP SLOPE LAND DISTURBANCE TAKES PLACE.
- ALL STORM SEWER INLETS WHICH ARE MADE OPERABLE DURING CONSTRUCTION SHALL BE PROTECTED BY EITHER AREA DRAIN PROTECTION, DIKE IN GRADED AREAS, OR BY WRAPPING FILTER FABRIC AROUND THE GRATE IN PAVED AREAS.
- WHEN EVER CONSTRUCTION VEHICLE ACCESS ROUTES INTERSECT PAVED PUBLIC ROADS, PROVISIONS SHOULD BE MADE TO MINIMIZE THE TRANSPORT OF SEDIMENT (MUD) BY RUNOFF OR VEHICLE TRACKING ONTO THE PAVED SURFACE.
- ALL TEMPORARY EROSION AND SEDIMENT CONTROL MEASURES SHOULD BE DISPOSED OF WITHIN 30 DAYS AFTER FINAL SITE STABILIZATION IS ACHIEVED OR AFTER THE TEMPORARY MEASURES ARE NO LONGER NEEDED. TRAPPED SEDIMENT AND OTHER DISTURBED SOIL AREAS RESULTING FROM THE DISPOSITION OF TEMPORARY MEASURES SHOULD BE PERMANENTLY STABILIZED TO PREVENT FURTHER EROSION AND SEDIMENTATION.
- ALL TEMPORARY AND PERMANENT EROSION AND SEDIMENT CONTROL MEASURES SHOULD BE MAINTAINED AND REPAIRED AS NEEDED TO ASSURE CONTINUED PERFORMANCE OF THEIR INTENDED FUNCTION.
- THE CONTRACTOR SHALL BE RESPONSIBLE FOR THE REMOVAL AND RESPREADING OF ANY MATERIAL THAT IS DEPOSITED OFF-SITE.
- ALL EROSION CONTROL MEASURES MUST BE INSPECTED WEEKLY & AFTER EACH 1/2" RAIN EVENT.
- ALL ADJACENT STREETS MUST BE KEPT CLEAR OF DEBRIS, INSPECTED DAILY & CLEANED WHEN NECESSARY.
- WINTER SHUT DOWN SHALL BE ADDRESSED EARLY IN THE FALL GROWING SEASON SO THAT SLOPES AND OTHER BARE EARTH AREAS MAY BE STABILIZED WITH TEMPORARY AND/OR PERMANENT VEGETATIVE COVER FOR PROPER EROSION AND SEDIMENT CONTROL.

SOIL PROTECTION SCHEDULE

STABILIZATION TYPE	JAN.	FEB.	MAR.	APR.	MAY	JUNE	JULY	AUG.	SEPT.	OCT.	NOV.	DEC.
PERMANENT SEEDING				A				A				
DORMANT SEEDING	B									A		
TEMPORARY SEEDING			B									
ER-BLANKET/HYDROMULCH	B							B				
MULCHING	C											

A- CLASS I IDOT SEEDING
B- CLASS II IDOT SEEDING
C- MULCH

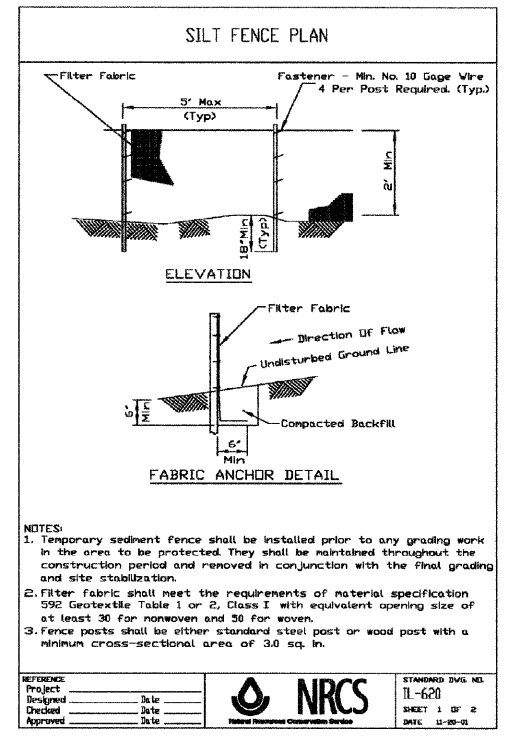

REFERENCE	Project	IL-530
Designed	Date	
Checked	Date	
Approved	Date	

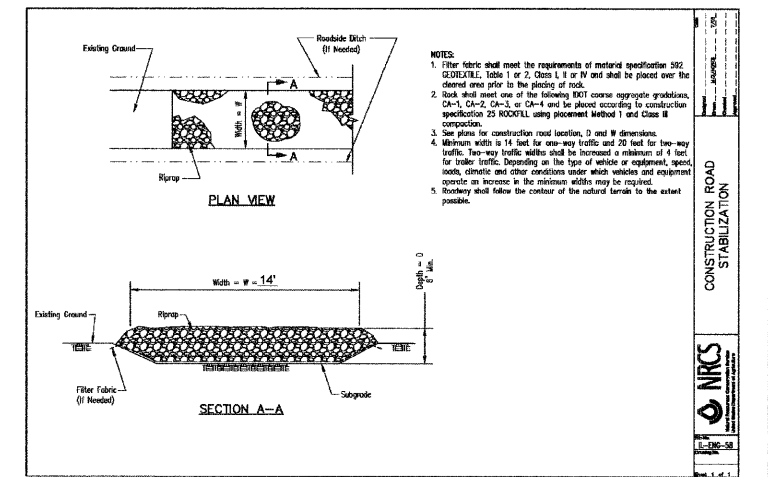

FILE NAME =	USER NAME =	DESIGNED -	REVISED -
m:\dgn\1\1\327\sheet\1\327_erosiondetals.dgn	_USER_	CHECKED -	REVISED -
		PLOT SCALE = 38.00 Ft / IN.	REVISED -
		PLOT DATE = 11/6/2008	REVISED -

DESIGNED -	REVISED -
CHECKED -	REVISED -
DRAWN -	REVISED -
CHECKED -	REVISED -

**STATE OF ILLINOIS
DEPARTMENT OF TRANSPORTATION**

**EROSION AND SEDIMENT
CONTROL NOTES AND DETAILS**

F.A. RTE.	SECTION	COUNTY	TOTAL SHEETS	SHEET NO.
	07-00050-00-BT	KANE	15	9
CONTRACT NO. 63097				
FED. ROAD DIST. NO.	ILLINOIS	FED. AID PROJECT		

SCALE: NONE SHEET NO. OF SHEETS STA. TO STA.