

# GRADING AROUND WINGWALLS

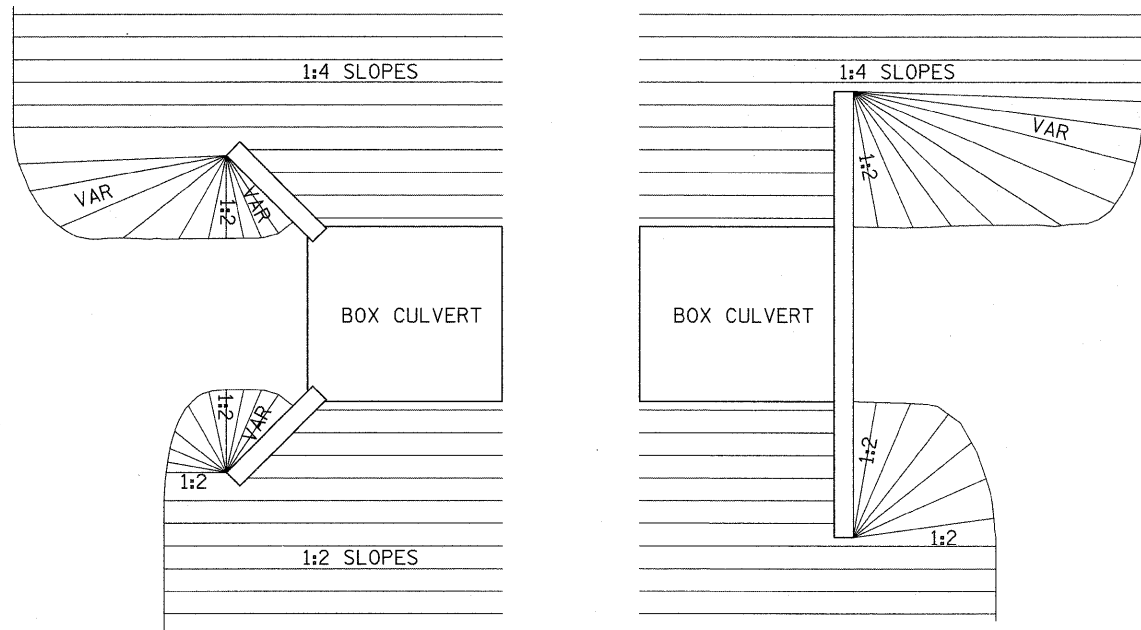

10-21-08

GRADING AROUND WINGWALLS 20.4

# DETAIL OF HOT-MIX ASPHALT SHOULDER AT GUARD RAIL

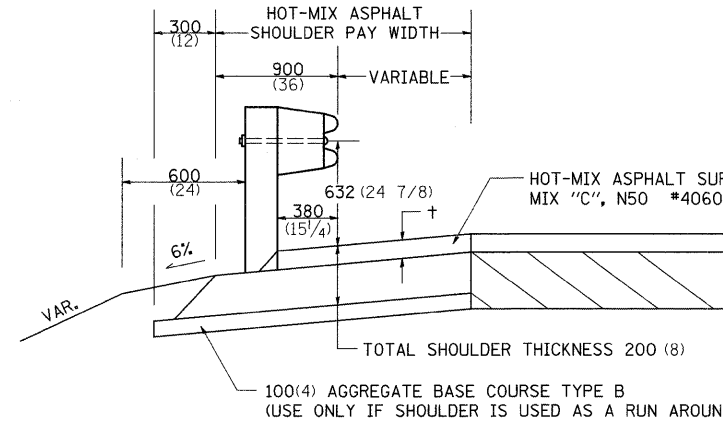

† = SEE TYPICAL SECTIONS FOR THICKNESS

### GENERAL NOTES

THE TOP LIFT SHALL NOT BE PLACED BEHIND THE GUARDRAIL POSTS. WHEN PLACING THE TOP LIFT THE RAIL MUST BE REMOVED FROM THE POSTS. THE POST SHALL NOT BE REMOVED.

THE HEIGHT OF THE GUARD RAIL SHALL BE SET 632 (24 7/8) FROM THE FINISHED SURFACE.

THE HOT-MIX ASPHALT SHOULDER SHALL BE CONSTRUCTED IN ACCORDANCE WITH SECTION 482 EXCEPT THE TOP LIFT SHALL BE HOT-MIX ASPHALT SURFACE COURSE, MIXTURE C, N50. THE WORK WILL BE PAID FOR AT THE CONTRACT UNIT PRICE PER TON FOR HOT-MIX ASPHALT SURFACE COURSE, MIXTURE "C", N50 AND SQUARE METER (SQUARE YARD) FOR HOT-MIX ASPHALT SHOULDERS OF THE THICKNESS SPECIFIED. THE REMOVAL & REINSTALLATION OF THE GUARDRAIL WILL BE INCLUDED IN THE COST OF THE HOT-MIX ASPHALT SURFACE COURSE, MIXTURE C, N50.

ALL DIMENSIONS ARE IN MILLIMETERS (INCHES) UNLESS OTHERWISE NOTED.

REVISED - 11-01-07

DETAIL OF HOT-MIX ASPHALT SHOULDER AT GUARD RAIL 23.4

# DELINEATOR AND POST ORIENTATION

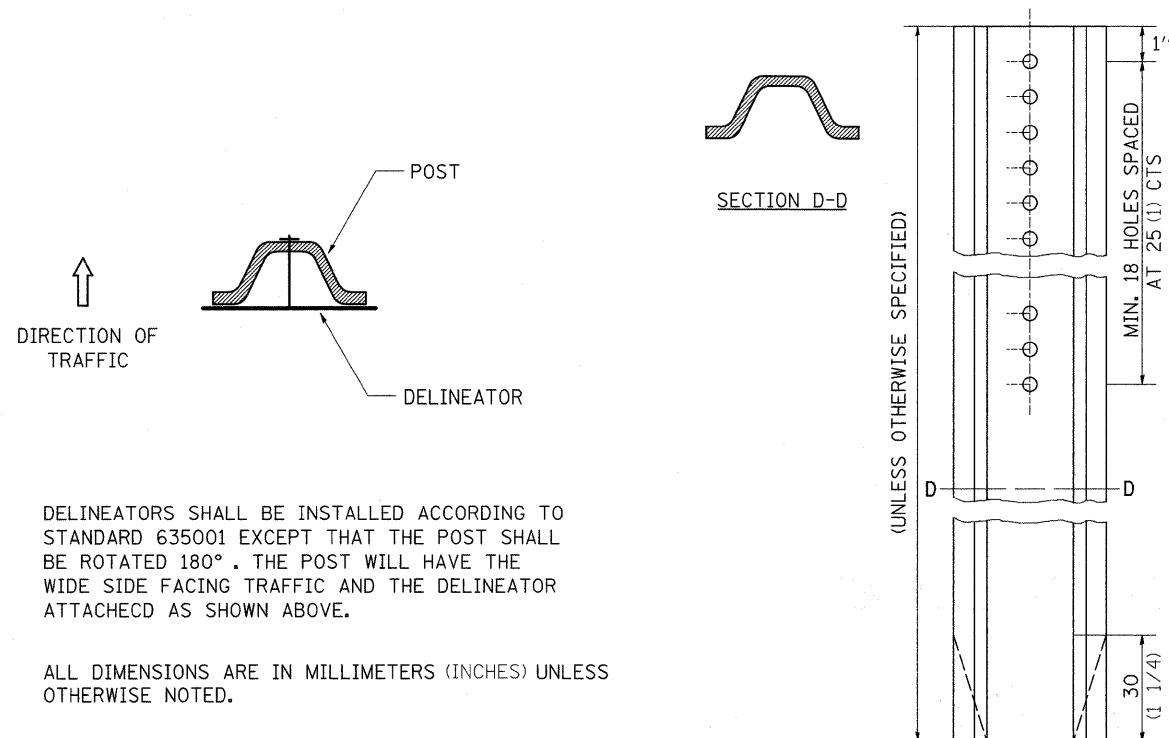

DELINEATORS SHALL BE INSTALLED ACCORDING TO STANDARD 635001 EXCEPT THAT THE POST SHALL BE ROTATED 180°. THE POST WILL HAVE THE WIDE SIDE FACING TRAFFIC AND THE DELINEATOR ATTACHED AS SHOWN ABOVE.

ALL DIMENSIONS ARE IN MILLIMETERS (INCHES) UNLESS OTHERWISE NOTED.

REVISED - 11-01-07

DELINEATOR AND POST ORIENTATION 37.4

# TYPICAL BENCHING ON EXISTING EMBANKMENT

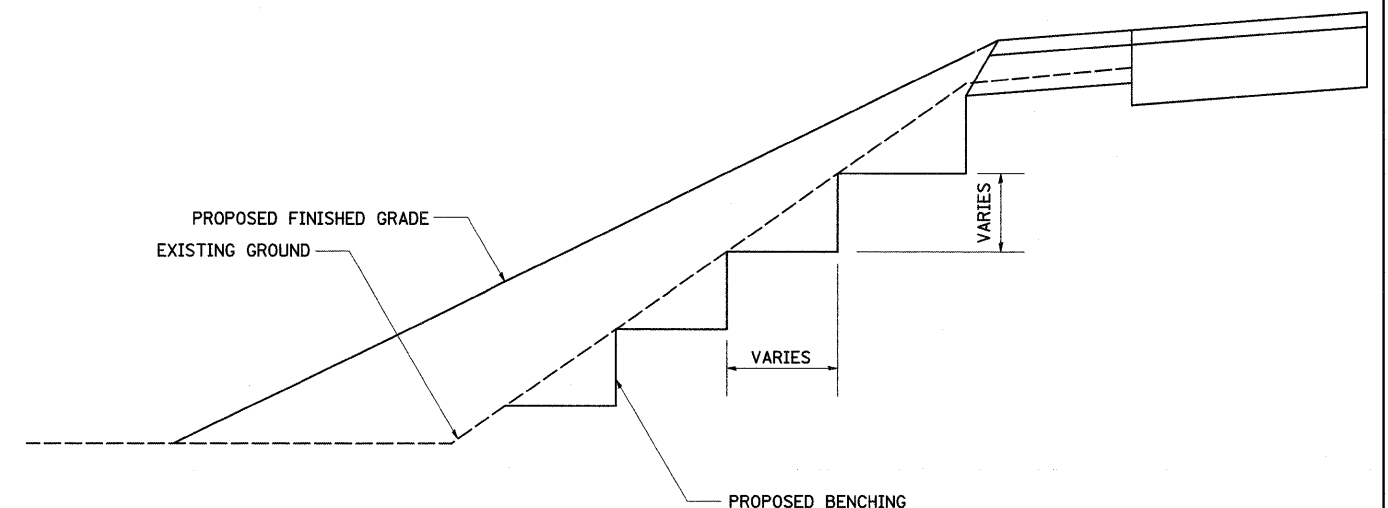

REVISED - 2-22-06	<b>REGION 2 / DISTRICT 2 STANDARD</b>	F.A.S. RTE.	SECTION	COUNTY	TOTAL SHEETS	SHEET NO.
REVISED -		1177	111T	LASALLE	59	40
REVISED -		CONTRACT NO. 64A07				
REVISED -		SCALE: 50,000' / IN	SHEET NO.	OF SHEETS	STA.	TO STA.

PLOT DATE = Wed Dec 24 14:22:43 2008

TYPICAL BENCHING ON EXISTING EMBANKMENT 50.4