

F.A. RTE.	SECTION	COUNTY	TOTAL SHEETS	SHEET NO.
840		IROQUOIS	16	16
STA.		TO STA.		
FED. ROAD DIST. NO.		ILLINOIS FED. AID PROJECT		

* (123)RS-1 & (135)RS-2

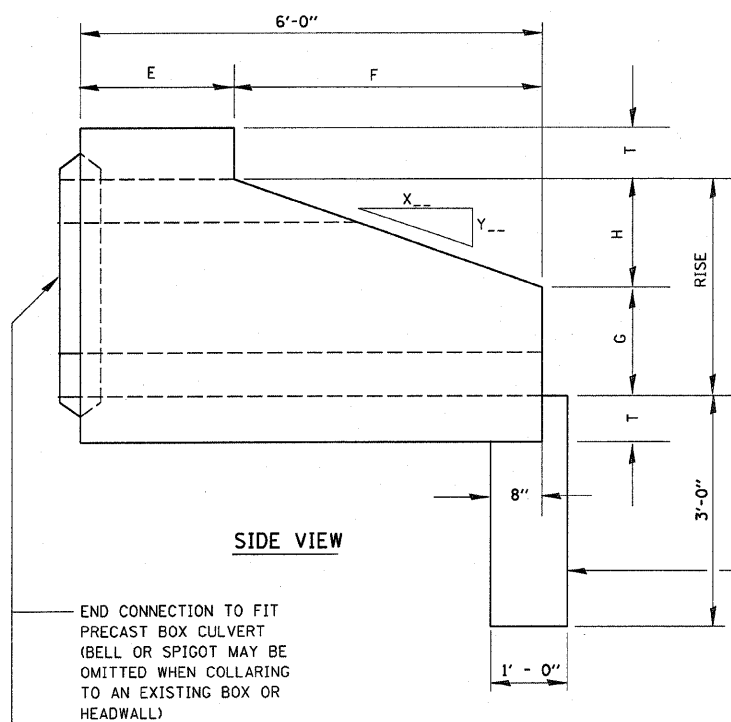

SIDE VIEW

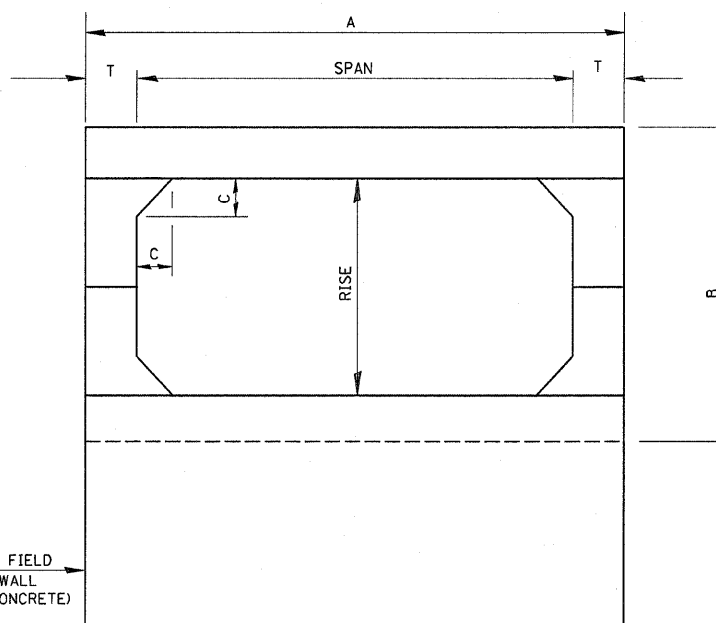

END VIEW

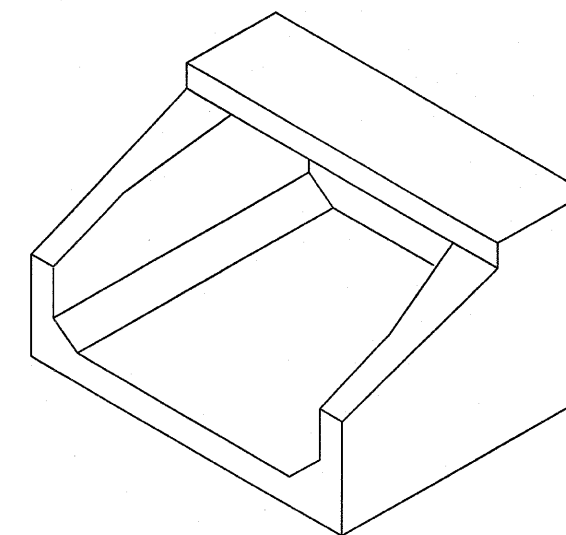

ISOMETRIC VIEW

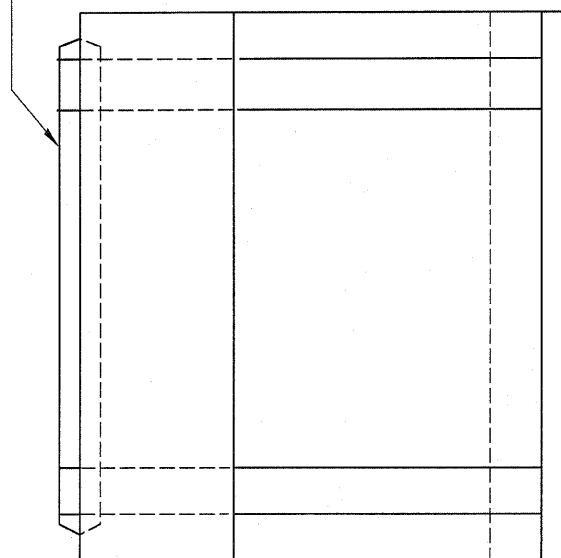

PLAN

PRECAST OR FIELD
POURED TOEWALL
(CLASS SI CONCRETE)

SPAN X RISE	T (INCHES)	A (FT.-IN.)	B (FT.-IN.)	C (INCHES)	E (FT.-IN.)	F (FT.-IN.)	G (FT.-IN.)	H (FT.-IN.)	SLOPE
2' X 2'	4	2 - 8	2 - 8	4	3 - 0	3 - 0	1 - 0	1 - 0	3 : 1
3' X 2'	4	3 - 8	2 - 8	4	3 - 0	3 - 0	1 - 0	1 - 0	3 : 1
3' X 3'	4	3 - 8	3 - 8	4	2 - 0	4 - 0	1 - 8	1 - 4	3 : 1
4' X 2'	5	4 - 10	2 - 10	5	3 - 0	3 - 0	1 - 0	1 - 0	3 : 1
4' X 3'	5	4 - 10	3 - 10	5	2 - 0	4 - 0	1 - 8	1 - 4	3 : 1
4' X 4'	5	4 - 10	4 - 10	5	2 - 0	4 - 0	2 - 0	2 - 0	2 : 1
5' X 2'	6	6 - 0	3 - 0	6	3 - 0	3 - 0	1 - 0	1 - 0	3 : 1
5' X 3'	6	6 - 0	4 - 0	6	2 - 0	4 - 0	1 - 8	1 - 4	3 : 1
5' X 4'	6	6 - 0	5 - 0	6	2 - 0	4 - 0	2 - 0	2 - 0	2 : 1
5' X 5'	6	6 - 0	6 - 0	6		4 - 0	3 - 0	2 - 0	2 : 1
6' X 2'	7	7 - 2	3 - 2	7	3 - 0	3 - 0	1 - 0	1 - 0	3 : 1
6' X 3'	7	7 - 2	4 - 2	7	2 - 0	4 - 0	1 - 8	1 - 4	3 : 1
6' X 4'	7	7 - 2	5 - 2	7	2 - 0	4 - 0	2 - 0	2 - 0	2 : 1
6' X 5'	7	7 - 2	6 - 2	7		4 - 0	3 - 0	2 - 0	2 : 1
7' X 3'	8	8 - 4	4 - 4	8		4 - 0	1 - 8	1 - 4	3 : 1
7' X 4'	8	8 - 4	5 - 4	8		4 - 0	2 - 0	2 - 0	2 : 1
7' X 5'	8	8 - 4	6 - 4	8		4 - 0	3 - 0	2 - 0	2 : 1
8' X 3'	8	9 - 4	4 - 4	8		4 - 0	1 - 8	1 - 4	3 : 1
8' X 4'	8	9 - 4	5 - 4	8		4 - 0	2 - 0	2 - 0	2 : 1
8' X 5'	8	9 - 4	6 - 4	8		4 - 0	3 - 0	2 - 0	2 : 1
9' X 3'	9	10 - 6	4 - 6	9		4 - 0	1 - 8	1 - 4	3 : 1
9' X 4'	9	10 - 6	5 - 6	9		4 - 0	2 - 0	2 - 0	2 : 1
9' X 5'	9	10 - 6	6 - 6	9		4 - 0	3 - 0	2 - 0	2 : 1
10' X 4'	10	11 - 8	5 - 9	10		4 - 0	2 - 0	2 - 0	2 : 1
10' X 5'	10	11 - 8	6 - 8	10		4 - 0	3 - 0	2 - 0	2 : 1

540-16

REVISIONS	
NAME	DATE

ILLINOIS DEPARTMENT OF TRANSPORTATION

PRECAST CONCRETE BOX
CULVERT END SECTION

SCALE: VERT.
HORIZ.
DATE

DRAWN BY
CHECKED BY