

NOTE:
LENGTH = 10' UNLESS
OTHERWISE NOTED ON PLANS.

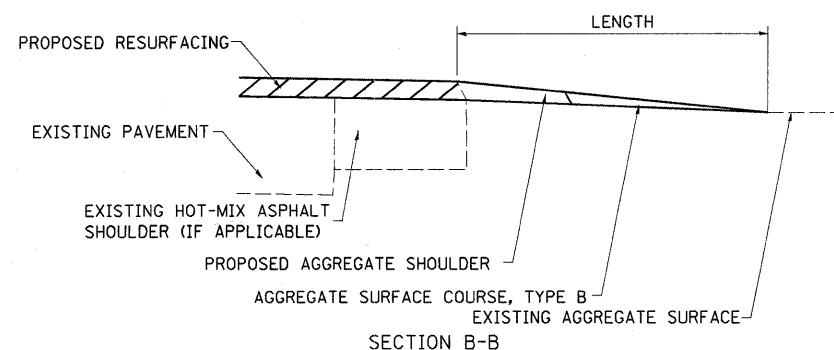

SECTION B-B

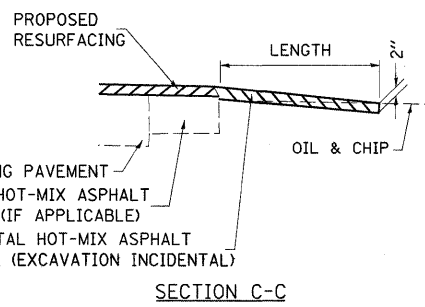
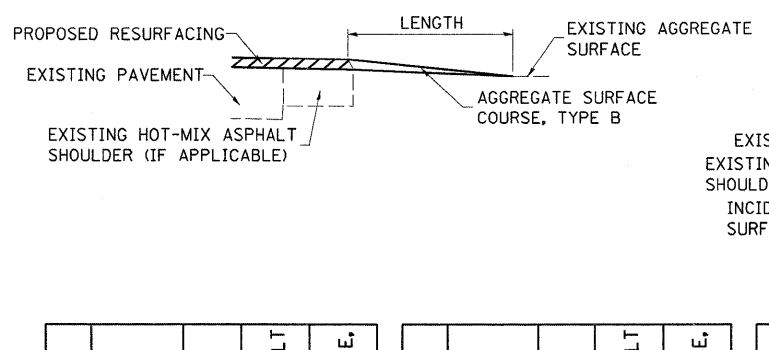

SECTION C-C

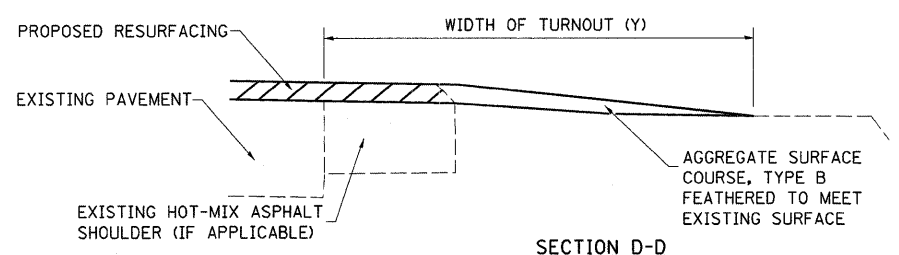
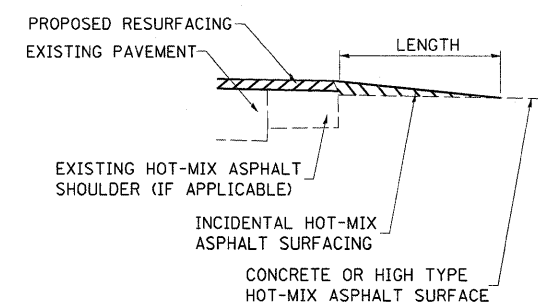

SECTION D-D

TYPICAL SECTION AT MAILBOX TURNOUT

NOTE: SEE STANDARD 406201 FOR MAILBOX TURNOUT DETAILS

NOTES

THE COST OF THE ASPHALT MATERIALS, AND AGGREGATE (PRIME COAT) FOR ENTRANCES AND PUBLIC ROADS AND APPROACHES SHALL BE INCLUDED IN THE PAY ITEM INCIDENTAL HOT-MIX ASPHALT SURFACING.

THE COST OF EXCAVATION IS INCLUDED IN THE PAY ITEM INCIDENTAL HOT-MIX ASPHALT SURFACING.

IF THERE IS NOT EXISTING HOT-MIX ASPHALT SHOULDER THEN THE ENTRANCE TAPER STARTS AT THE EDGE OF EXISTING PAVEMENT.

SIDE	STATION	TYPE	INCIDENTAL HOT-MIX ASPHALT SURFACING	AGGREGATE SURFACE COURSE, TYPE B
			TON	TON
RT	611+00	PE	1.7	
RT	622+60	PRA	2.3	
	TOTAL		4.0	

SIDE	STATION	TYPE	INCIDENTAL HOT-MIX ASPHALT SURFACING	AGGREGATE SURFACE COURSE, TYPE B
			TON	TON

SIDE	STATION	TYPE	INCIDENTAL HOT-MIX ASPHALT SURFACING	AGGREGATE SURFACE COURSE, TYPE B
			TON	TON

SIDE	STATION	TYPE	INCIDENTAL HOT-MIX ASPHALT SURFACING	AGGREGATE SURFACE COURSE, TYPE B
			TON	TON

SIDE	STATION	TYPE	INCIDENTAL HOT-MIX ASPHALT SURFACING	AGGREGATE SURFACE COURSE, TYPE B
			TON	TON

FE=FIELD ENTRANCE PRA - PUBLIC ROAD APPROACH
PE=PRIVATE ENTRANCE MBT - MAILBOX TURNOUT
CE=COMMERCIAL ENTRANCE