

**NEW CONSTRUCTION**

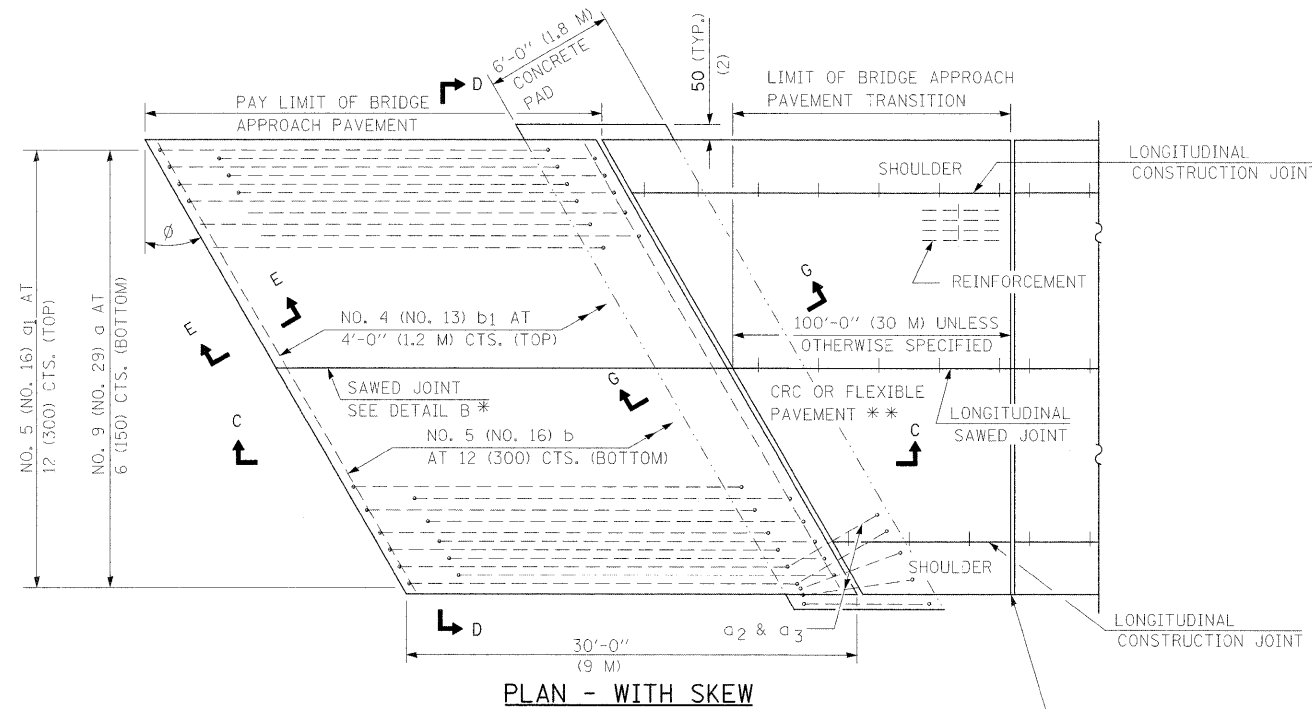

**PLAN - WITH SKEW**

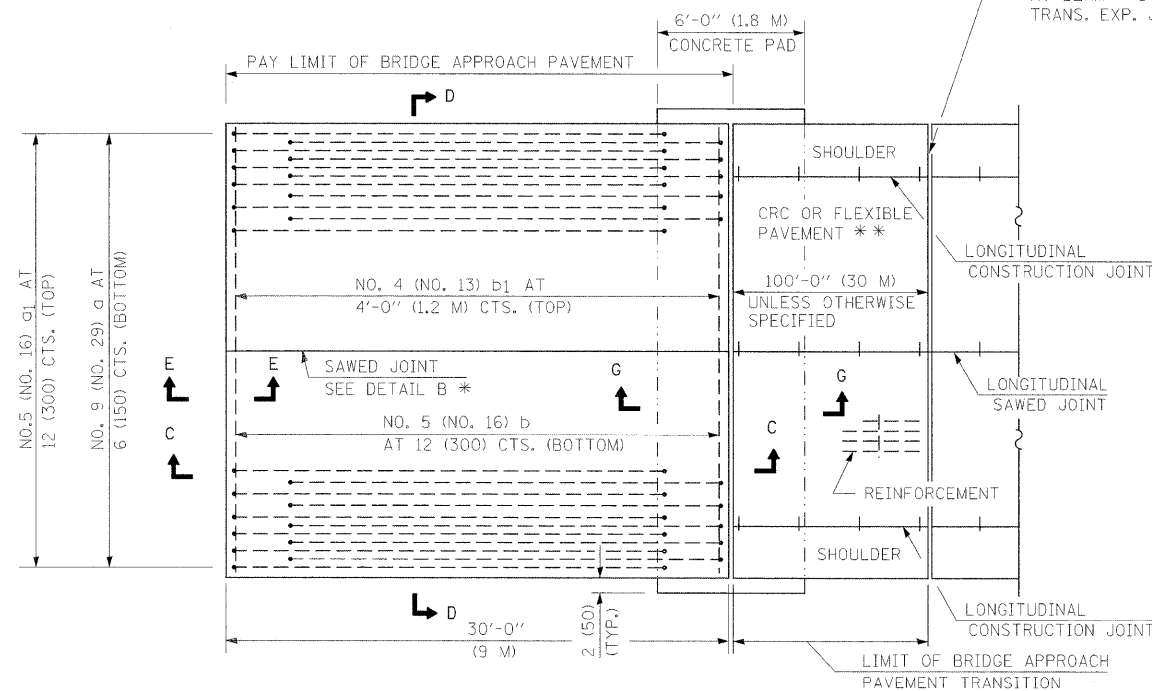

**PLAN - WITHOUT SKEW**

\* SAW  $\phi$  OR LANE EDGE IF POURED TWO OR MORE LANE WIDTHS AT A TIME.  
 \*\* OMIT REINFORCEMENT, TIE BARS AND LONG. SAWED JT. FOR FLEXIBLE PAVEMENT.

RIGID PAVEMENT ONLY:  
 WIDE FLANGE BEAM TERMINAL JOINT (SEE DETAIL AT BEAM - STANDARD 421101 OR 421106) OR 2 (50) TRANS. EXP. JOINT AS DETAILED ON STANDARD 420001.

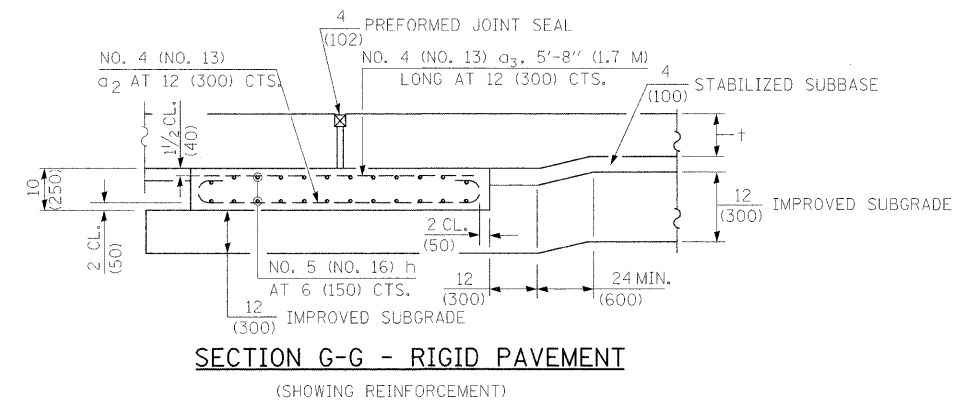
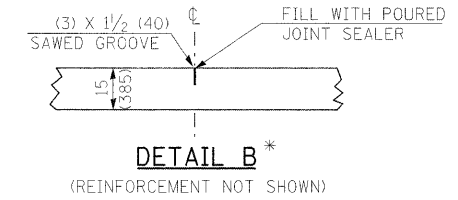

**SECTION G-G - RIGID PAVEMENT**

(SHOWING REINFORCEMENT)

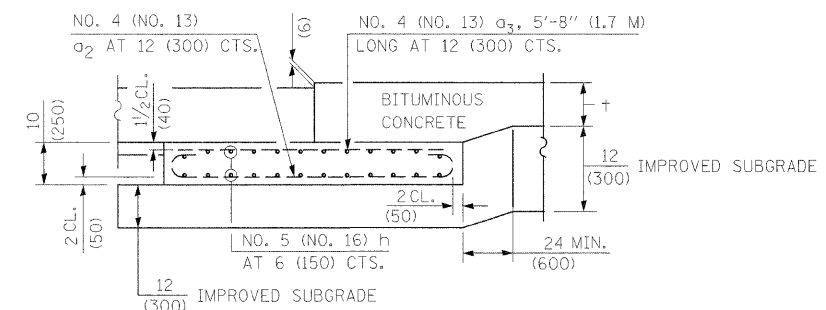

**SECTION G-G - FLEXIBLE PAVEMENT**

(SHOWING REINFORCEMENT)

**GENERAL NOTES**

THICKNESS-"t"=THICKNESS OF PAVEMENT.  
 SEE STANDARD 421001 FOR REINFORCEMENT DETAILS NOT SHOWN.  
 SEE STANDARD 420001 FOR JOINT DETAILS NOT SHOWN.  
 ALL DIMENSIONS ARE IN INCHES (MILLIMETERS) UNLESS OTHERWISE SHOWN.

FILE NAME =	USER NAME = harbaughrd	DESIGNED -	REVISED -	<b>STATE OF ILLINOIS DEPARTMENT OF TRANSPORTATION</b>	<b>MISCELLANEOUS DETAILS BRIDGE APPROACH PAVEMENT DETAIL</b>			F.A.P. RTE.	SECTION	COUNTY	TOTAL SHEETS	SHEET NO.
01\pw\work\pwr\d01\harbaughrd\dms51889\p01506a.dgn	PLOT SCALE = 50.0000' / IN.	DRAWN -	REVISED -					761	104-BR-2	GREENE	82	74
PLOT DATE = 12/18/2008	DATE -	CHECKED -	REVISED -		SCALE: SHEET NO. 1 OF 4 SHEETS STA. TO STA.			CONTRACT NO. 76987				
		DATE -	REVISED -		FED. ROAD DIST. NO. ILLINOIS FED. AID PROJECT							