

F.A.P. RTE.	SECTION	COUNTY	TOTAL SHEETS	SHEET NO.
328	109RS-2	WHITE	15	1

STATE OF ILLINOIS
DEPARTMENT OF TRANSPORTATION
DIVISION OF HIGHWAYS

PROPOSED HIGHWAY PLANS

FAP 328 (US 45)
SECTION 109RS-2
PROJECT NO. ACF-0328(025)
WHITE COUNTY
C-99-052-08

FOR INDEX OF SHEETS, SEE SHEET NO. 3
FOR SUMMARY OF QUANTITIES, SEE SHEET NO. 4

STATION EQUATIONS

STA EQ 163+35.9 @ BK = STA 163+39.7 @ AH
STA EQ 174+35.3 @ BK = STA 174+53.5 @ AH
STA EQ 238+92.8 @ BK = STA 238+95.9 @ AH
STA EQ 277+14.2 @ BK = STA 277+69.1 @ AH
STA EQ 303+08.5 @ BK = STA 304+13.3 @ AH

TRAFFIC DATA

US 45 TRAFFIC DATA
2005 ADT = 1,800 WITH 21% TRUCKS

TOWNSHIPS

INDIAN CREEK
ENFIELD



APPROXIMATE SCALE

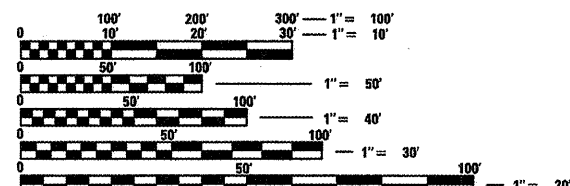

FULL SIZE PLANS HAVE BEEN PREPARED USING STANDARD ENGINEERING SCALES. REDUCED SIZED PLANS WILL NOT CONFORM TO STANDARD SCALES. IN MAKING MEASUREMENTS ON REDUCED PLANS, THE ABOVE SCALES MAY BE USED.

J.U.L.I.E.
JOINT UTILITY LOCATION INFORMATION FOR EXCAVATION
1-800-892-0123 or www.julie1call.com

CONTRACT NO. 78066

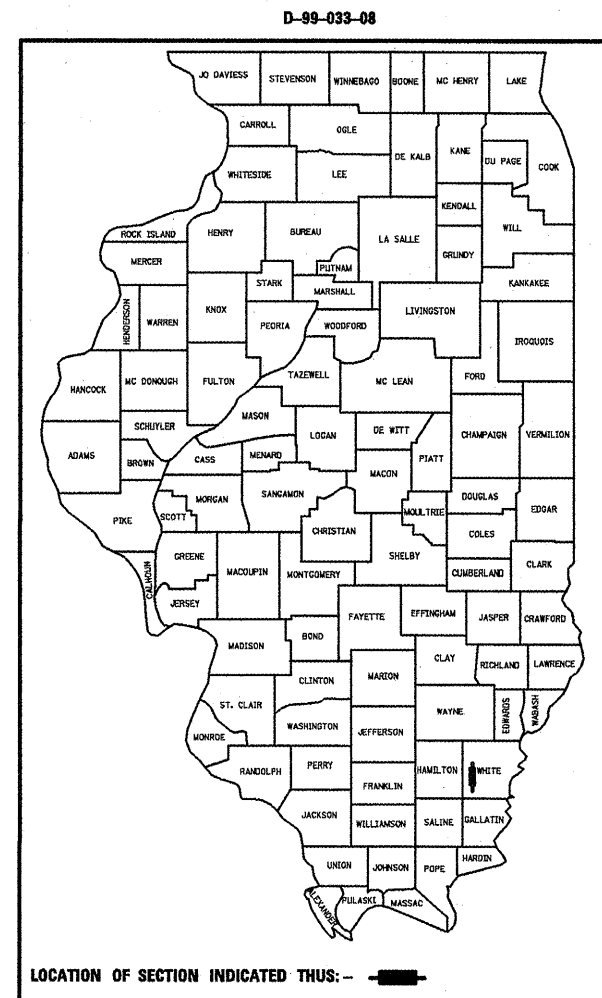

LOCATION OF SECTION INDICATED THUS: ———

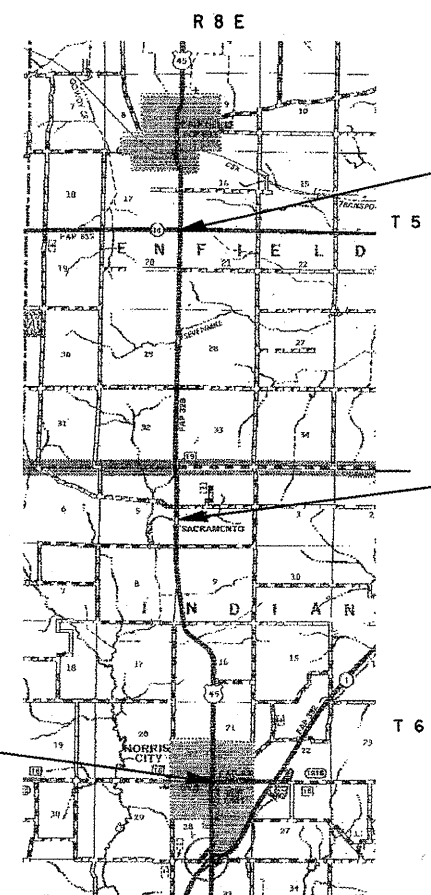

PROPOSED IMPROVEMENT
FAP 328 (US 45)
SECTION 109RS-2
WHITE COUNTY
BEGINS STA. 0+60.00

GAP IMPROVEMENT
STRUCTURE NUMBER 097-2007
STA. 193+82.0 TO STA. 194+24.0

PROPOSED IMPROVEMENT
FAP 328 (US 45)
SECTION 109RS-2
WHITE COUNTY
ENDS STA. 381+90.00

GROSS LENGTH OF PROJECT = 37,908.20 FT = 7.180 MILES
NET LENGTH OF PROJECT = 37,836.20 FT = 7.166 MILES

STATE OF ILLINOIS
DEPARTMENT OF TRANSPORTATION
DIVISION OF HIGHWAYS

SUBMITTED *Dec 2 20 08*
Min [Signature]
DEPUTY DIRECTOR OF HIGHWAYS, REGION ENGINEER

January 30 20 09
Charles J. Ingersoll
ENGINEER OF DESIGN AND ENVIRONMENT

January 30 20 09
Christine M. Reed
DIRECTOR OF HIGHWAYS, CHIEF ENGINEER

PRINTED BY THE AUTHORITY
OF THE STATE OF ILLINOIS

GENERAL NOTES

FACTORS USED FOR ESTIMATING PLAN QUANTITIES ARE AS FOLLOWS AND SHALL NOT BE USED FOR THE BASIS OF FINAL QUANTITIES:

ALL HOT-MIX ASPHALT
2.016 TONS/CU. YD.

BITUMINOUS MATERIALS:

ON PAVEMENT
0.09 GAL./SQ. YD.

INTERMEDIATE LIFTS (FOG COAT)
0.04 GAL./SQ. YD.

ON AGGREGATE SURFACE
0.32 GAL./SQ. YD.

AGGREGATE (PRIME COAT)
0.0015 TONS/SQ. YD.

ALL AGGREGATE
2.05 TONS/CU. YD.

THE QUANTITY OF SHORT TERM PAVEMENT MARKING IS BASED ON THREE APPLICATIONS, ONE EACH FOR HMA LEVELING BINDER, HMA SURFACE COURSE AND HMA SURFACE REMOVAL.

THE QUANTITY OF AGGREGATE SHOULDER, TYPE B IS BASED ON AN EXTRA 2" DEPTH DUE TO SETTLING OF EXISTING MATERIAL AND TAPER AT EXISTING FIELD ENTRANCES.

THE QUANTITY OF AGGREGATE PRIME COAT IS BASED ON ONE APPLICATION EACH FOR BINDER AND SURFACE COURSE.

SAW CUTS FOR PAVEMENT AND ENTRANCE BUTT JOINTS SHALL BE INCLUDED IN THE COST OF THE HMA SURFACE REMOVAL-BUTT JOINT OR THE PCC SURFACE REMOVAL-BUTT JOINT.

THE CONTRACTOR SHALL STAMP STATIONING IN THE PROPOSED HOT MIX ASPHALT SURFACE AT 300 FT. INTERVALS ON ALTERNATING SIDES OF THE PAVEMENT AND AS DIRECTED BY THE ENGINEER. THE STATION SYMBOL STAMPS USED SHALL BE FURNISHED BY THE CONTRACTOR. THEY SHALL BE 5.5 IN. TALL, OF A DESIGN APPROVED BY THE ENGINEER, AND SHALL REMAIN THE PROPERTY OF THE CONTRACTOR. STATIONING FOR THIS PROJECT IS INCREASING TO THE SOUTH.

PRIOR TO PLACEMENT OF THE FINAL PAVEMENT MARKINGS THE RESIDENT ENGINEER SHALL CONTACT THE BUREAU OF OPERATIONS AND ARRANGE FOR INSPECTION AND APPROVAL OF THE PAVEMENT MARKING LAYOUT.

IN ADDITION TO THE REQUIREMENTS OF ARTICLE 107.16, THE CONTRACTOR SHALL PROTECT THE SURFACE OF ALL BRIDGE DECK AND BRIDGE APPROACH PAVEMENTS IN A MANNER SATISFACTORY TO THE ENGINEER BEFORE ANY EQUIPMENT IS ALLOWED TO CROSS THE STRUCTURE. PROTECTION SHALL BE PROVIDED FOR ALL EQUIPMENT AS DEFINED IN ARTICLE 101.17 REGARDLESS OF TRACK MOUNTED OR WHEELED.

Prepared By: Joe N. Daniewicz
DISTRICT STUDIES & PLANS ENGINEER

Examined By: James Louis Emery
DISTRICT LAND ACQUISITION ENGINEER

Examined By: Carrie Nelson
DISTRICT PROGRAM DEVELOPMENT ENGINEER

Examined By: Kevin M. Hammer
DISTRICT OPERATIONS ENGINEER

Examined By: Jim Smother
DISTRICT CONSTRUCTION ENGINEER

Examined By: Bruce B. Pebles
DISTRICT MATERIALS ENGINEER

Examined By: Jim Smother
DISTRICT PROJECT IMPLEMENTATION ENGINEER

Examined By: Danney L. Clanton
ASSISTANT REGIONAL ENGINEER

Approved By: My Chami
DEPUTY DIRECTOR OF HIGHWAYS, REGION 5 ENGINEER

Dec 2 2008
DATE

FILE NAME *	USER NAME = sheperdgd	DESIGNED - ---	REVISED - ---	STATE OF ILLINOIS DEPARTMENT OF TRANSPORTATION	GENERAL NOTES AND SIGNATURE SHEET	F.A.P. RTE. 328	SECTION 109R5-2	COUNTY WHITE	TOTAL SHEETS 14	SHEET NO. 2
ca:\pwr\work\pwr\dtd\sheperdgd\dms49876\dms49876.sht.miso.dgn		DRAWN - ---	REVISED - ---							
	PLOT SCALE = 100.0000' / IN.	CHECKED - ---	REVISED - ---							
	PLOT DATE = 11/12/2008	DATE - ---	REVISED - ---							
					SCALE: -----	SHEET NO. 2 OF 14 SHEETS		STA. ----- TO STA. -----		
					FED. ROAD DIST. NO. - ILLINOIS FED. AID PROJECT					
					CONTRACT NO. 78066					

INDEX OF SHEETS

SHEET NO.	DESCRIPTION
1	COVER SHEET
2	GENERAL NOTES AND SIGNATURE SHEET
3	INDEX OF SHEETS, COMMITMENTS, MIXTURE REQUIREMENTS, HIGHWAY STANDARDS AND STRUCTURES
4	SUMMARY OF QUANTITIES
5	TYPICAL SECTIONS
6	TYPICAL SECTIONS
7	TYPICAL SECTIONS
8	SIDEROAD AND ENTRANCE SCHEDULE
9	PAVEMENT AND RESURFACING SCHEDULE
10	PAVEMENT MARKING SCHEDULES
11	RUMBLE STRIP AND PATCHING SCHEDULES
12	PATCHING SCHEDULE
13	DETAILS: BUTT JOINTS AND PAVEMENT TRANSITIONS
14	DETAILS: BUTT JOINTS, PAVEMENT TRANSITION AND RUMBLE STRIP DETAILS
15	DETAILS: SIDEROAD AND ENTRANCE DETAILS HIGHWAY STANDARDS

MIXTURE REQUIREMENTS

LOCATION(S):	HOT-MIX ASPHALT SURFACE COURSE, MIX C, N90
MIXTURE USE(S):	HOT-MIX ASPHALT SURFACE COURSE, MIX C, N90
AC/PG:	PG64-22
RAP % (MAX):	10
DESIGN AIR VOIDS:	4.0 %, 90 GYRATION DESIGN
MIXTURE COMPOSITION: (GRADATION MIXTURE)	IL-9.5 MM OR IL12.5 MM
FRICTION AGGREGATE:	C SURFACE

LOCATION(S):	LEVELING BINDER (MACHINE METHOD), N90
MIXTURE USE(S):	HOT-MIX ASPHALT SURFACE COURSE, MIX C, N90
AC/PG:	PG64-22
RAP % (MAX):	10
DESIGN AIR VOIDS:	4.0 %, 90 GYRATION DESIGN
MIXTURE COMPOSITION: (GRADATION MIXTURE)	IL-9.5 MM OR IL12.5 MM
FRICTION AGGREGATE:	C SURFACE

LOCATION(S):	INCIDENTAL HMA SURFACING
MIXTURE USE(S):	HOT-MIX ASPHALT SURFACE COURSE, MIX C, N90
AC/PG:	PG64-22
RAP % (MAX):	10
DESIGN AIR VOIDS:	4.0 %, 90 GYRATION DESIGN
MIXTURE COMPOSITION: (GRADATION MIXTURE)	IL-9.5 MM OR IL12.5 MM
FRICTION AGGREGATE:	C SURFACE

HIGHWAY STANDARDS

STANDARD NUMBER	TITLE
000001-05	STANDARD SYMBOLS, ABBREVIATIONS AND PATTERNS
442201-03	CLASS C AND D PATCHES
701006-03	OFF-ROAD OPERATIONS, 2L, 2W, 4.5 M (15') TO 600 MM (24") FROM PAVEMENT EDGE
701011-02	OFF-ROAD MOVING OPERATIONS, 2L, 2W, DAY ONLY
701301-03	LANE CLOSURE, 2L, 2W, SHORT TIME OPERATIONS
701306-02	LANE CLOSURE, 2L, 2W, SLOW MOVING OPERATIONS DAY ONLY, FOR SPEEDS > 45 MPH
701311-03	LANE CLOSURE, 2L, 2W, MOVING OPERATIONS - DAY ONLY
701336-05	LANE CLOSURE, 2L, 2W, WORK AREAS IN SERIES, FOR SPEEDS > 45 MPH
701501-05	URBAN LANE CLOSURE, 2L, 2W, UNDIVIDED
701901-01	TRAFFIC CONTROL DEVICES
780001-02	TYPICAL PAVEMENT MARKINGS
781001-03	TYPICAL APPLICATIONS RAISED REFLECTIVE PAVEMENT MARKERS

STRUCTURES WITHIN PROJECT LIMITS

Structure No.	Operating Rating	Inventory Rating	Posting
097-2007	15.0	9.0	NONE
097-2012	50.9	30.5	NONE

AS PER BRIDGE OFFICE: A LOADED MTD IS ALLOWED OVER SN 097-2012 AND AN EMPTY MTD ONLY OVER SN 097-2007.

COMMITMENTS

NONE AS OF 12/12/2008

SUMMARY OF QUANTITIES

CODE NUMBER	ITEM DESCRIPTION	UNIT	TOTAL QUANTITY	STP-RURAL-STATE	STP-RURAL-STATE
				80% FED / 20% STATE	80% FED / 20% STATE
				WHITE COUNTY	WHITE COUNTY
				1000 QUANTITY	1000 QUANTITY
35102000	AGGREGATE BASE COURSE TYPE B, 8"	SO YD	545	545	
40600100	BITUMINOUS MATERIALS(PRIME COAT)	GAL/DN	14454	13411	1043
40600300	AGGREGATE(PRIME COAT)	TON	321	301	20
40600400	MIXTURE FOR CRACKS, JOINTS, AND FLANGEWAYS	TON	30	27	3
40600645	LEVELING BINDER (MACHINE METHOD), N90	TON	4597	4260	337
40600895	CONSTRUCTING TEST STRIP	EACH	1	1	0
40600982	HOT-MIX ASPHALT SURFACE REMOVAL - BUTT JOINT	SO YD	804	718	86
40600985	PORTLAND CEMENT CONCRETE SURFACE REMOVAL - BUTT JOINT	SO YD	98	98	
40600990	TEMPORARY RAMP	SO YD	71	44	27
40603320	HOT-MIX ASPHALT SURFACE COURSE, MIX "C", N90	TON	9236	8559	677
40800050	INCIDENTAL HOT-MIX ASPHALT SURFACING	TON	138	138	
44000153	HOT-MIX ASPHALT SURFACE REMOVAL, 1"	SO YD	97476	97476	
44000155	HOT-MIX ASPHALT SURFACE REMOVAL, 1 1/2"	SO YD	3925	3925	
44000158	HOT-MIX ASPHALT SURFACE REMOVAL, 2 1/4"	SO YD	8023		8023
44200128	PAVEMENT PATCHING, TYPE I, 11 INCH	SO YD	6.6	6.6	
44200132	PAVEMENT PATCHING, TYPE II, 11 INCH	SO YD	2598.0	2433.4	164.6
44200136	PAVEMENT PATCHING, TYPE III, 11 INCH	SO YD	814.7	793.0	21.7
44200138	PAVEMENT PATCHING, TYPE IV, 11 INCH	SO YD	1015.5	951.6	63.9
44300200	STRIP REFLECTIVE CRACK CONTROL TREATMENT	FOOT	75807	70427	5380
48101200	AGGREGATE SHOULDERS, TYPE B	TON	4164	4164	
60255500	MANHOLES TO BE ADJUSTED	EACH	4		4
67000500	ENGINEER'S FIELD OFFICE, TYPE B	CAL MO	8	6	2
67100100	MOBILIZATION	L SUM	1	0.9	0.1
70100460	TRAFFIC CONTROL AND PROTECTION, STANDARD 701306	L SUM	1	1	
70100600	TRAFFIC CONTROL AND PROTECTION, STANDARD 701336	L SUM	1	1	
70102620	TRAFFIC CONTROL AND PROTECTION, STANDARD 701501	L SUM	1		1
70300100	SHORT-TERM PAVEMENT MARKING	FOOT	10977	9616	1361
70300220	TEMPORARY PAVEMENT MARKING - LINE 4"	FOOT	102581	96611	5970
70301000	WORK ZONE PAVEMENT MARKING REMOVAL	SO FT	34194	32204	1990
* 78001110	PAINT PAVEMENT MARKING - LINE 4"	FOOT	102581	96611	5970
* 78100100	RAISED REFLECTIVE PAVEMENT MARKER	EACH	475	441	34
78300200	RAISED REFLECTIVE PAVEMENT MARKER REMOVAL	EACH	475	441	34
X0322729	MATERIAL TRANSFER DEVICE	TON	13833	12819	1014
Z0055500	RUMBLE STRIP	SO FT	1196	1196	
Z0075310	TIE BARS 3/4"	EACH	437	397	40

**Specialty Items*

TYPICAL SECTION #1

WHITE COUNTY
FAP 328 (US 45)
(LOOKING IN DIRECTION OF INCREASING STATIONING)

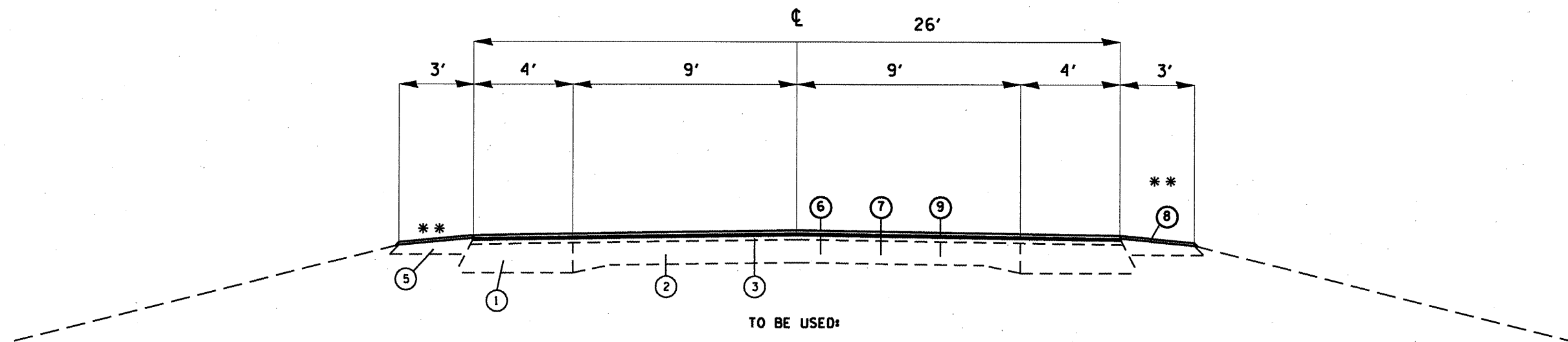

TO BE USED:

STA 0+60.0 TO STA 163+35.9
STA 163+39.7 TO STA 174+00.0
STA 188+90.0 TO STA 193+82.0
STA 194+24.0 TO STA 238+92.8
STA 238+95.9 TO STA 277+14.2
STA 277+69.1 TO STA 303+08.5
STA 304+13.3 TO STA 373+00.0

- ① EXISTING BASE COURSE WIDENING, 9"
- ② EXISTING PAVEMENT STRUCTURE
- ③ EXISTING HOT MIX ASPHALT RESURFACING, 3 1/2" TYP.
- ④ EXISTING CONCRETE GUTTER, TYPE B (MODIFIED)
- ⑤ EXISTING AGGREGATE SHOULDERS

- ⑥ PROPOSED HMA SURFACE COURSE, 1 1/2"
- ⑦ PROPOSED HMA LEVELING BINDER, 3/4"
- ⑧ PROPOSED AGGREGATE SHOULDERS, 1 1/4"
- ⑨ PROPOSED HMA SURFACE REMOVAL, 1"
- ⑩ PROPOSED HMA SURFACE REMOVAL, 1 1/2"
- ⑪ PROPOSED AGGREGATE SHOULDERS, 1 1/4"
- ⑫ PROPOSED BITUMINOUS SHOULDERS SUPERPAVE 4 1/2" TO 2" MIN
- ⑬ PROPOSED BITUMINOUS SHOULDERS SUPERPAVE 4 1/2" TO 2" MIN

TYPICAL SECTION #2

WHITE COUNTY
FAP 328 (US 45)
LOOKING IN DIRECTION OF INCREASING STATIONING

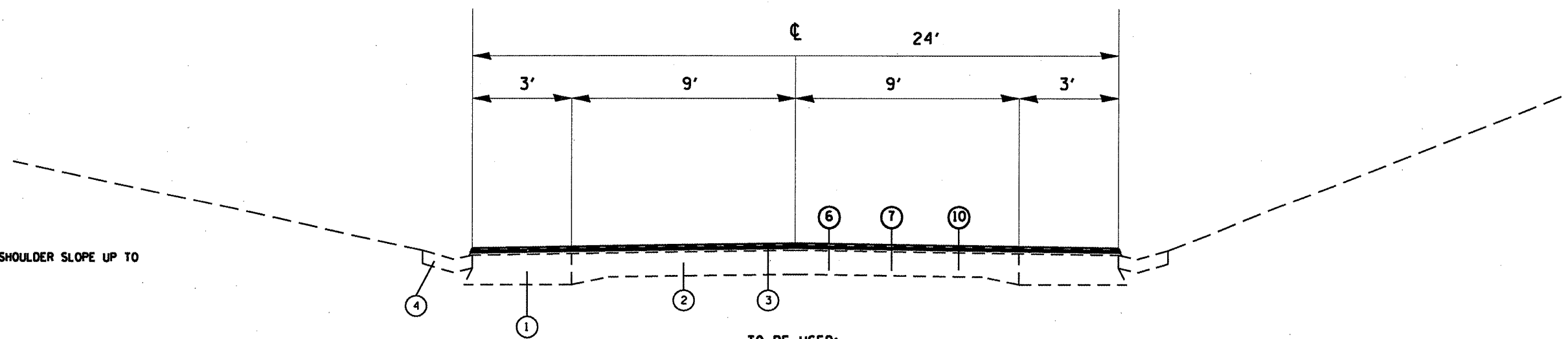

TO BE USED:

STA 174+00.0 TO STA 174+35.3
STA 174+53.5 TO STA 188+90.0

NOTES:

** MATCH EXISTING SHOULDER SLOPE UP TO 6% MAXIMUM.

FILE NAME =	USER NAME = shepardgd	DESIGNED - ---	REVISED - ---	STATE OF ILLINOIS DEPARTMENT OF TRANSPORTATION	TYPICAL SECTIONS		F.A.P. RTE. 328	SECTION 109RS-2	COUNTY WHITE	TOTAL SHEETS 15	SHEET NO. 5
ct:\p\work\p\wdot\shepardgd\dms49876\d	78066_sht_miso.dgn	DRAWN - ---	REVISED - ---		SCALE: _____	SHEET NO. 5 OF 14 SHEETS	STA. _____ TO STA. _____	FED. ROAD DIST. NO. ILLINOIS FED. AID PROJECT		CONTRACT NO. 78066	
	PLOT SCALE = 100.0000' / IN.	CHECKED - ---	REVISED - ---								
	PLOT DATE = 12/4/2008	DATE - -----	REVISED - ---								

TYPICAL SECTION #3

WHITE COUNTY
FAP 328 (US 45)
(LOOKING IN DIRECTION OF INCREASING STATIONING)

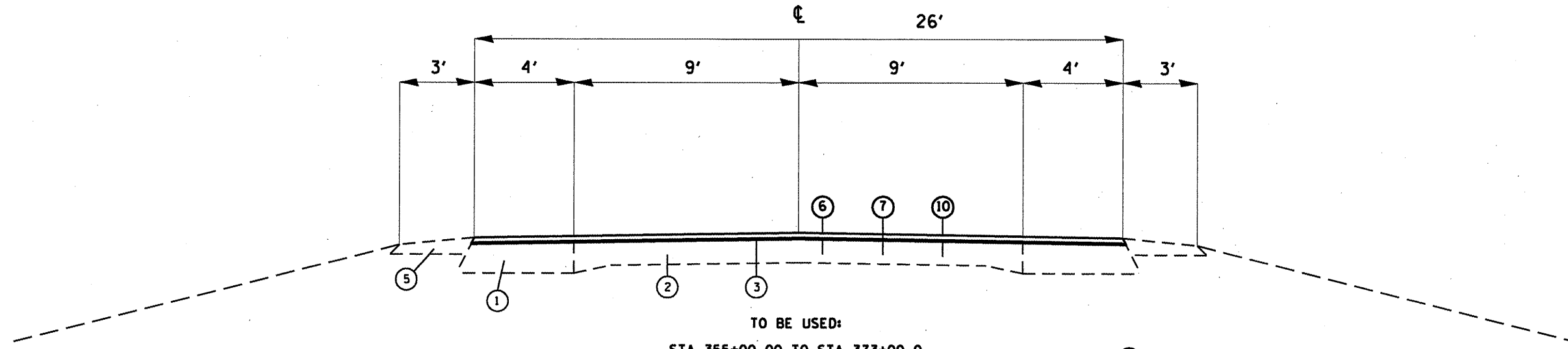

TO BE USED:
STA 355+00.00 TO STA 373+00.0

⑥ PROPOSED HMA SURFACE COURSE, 1 1/2"

- ① EXISTING BASE COURSE WIDENING, 9"
- ② EXISTING PAVEMENT STRUCTURE
- ③ EXISTING HOT MIX ASPHALT RESURFACING, 3 1/2" TYP.
- ④ EXISTING CONCRETE GUTTER, TYPE B (MODIFIED)
- ⑤ EXISTING AGGREGATE SHOULDERS
- ⑥ EXISTING COMBINATION CONCRETE CURB AND GUTTER, SPECIAL

- ⑥ PROPOSED HMA SURFACE COURSE, 1 1/2"
- ⑦ PROPOSED HMA LEVELING BINDER, 3/4"
- ⑧ PROPOSED AGGREGATE SHOULDERS, 1 1/4"
- ⑨ PROPOSED HMA SURFACE REMOVAL, 1"
- ⑩ PROPOSED HMA SURFACE REMOVAL, 2 1/4"
- ⑪ PROPOSED AGGREGATE SHOULDERS, 1 1/4"
- ⑫ PROPOSED BITUMINOUS SHOULDERS SUPERPAVE 4 1/2" TO 2" MIN
- PROPOSED BITUMINOUS SHOULDERS SUPERPAVE 4 1/2" TO 2" MIN

TYPICAL SECTION #4

WHITE COUNTY
FAP 328 (US 45)
LOOKING IN DIRECTION OF INCREASING STATIONING)

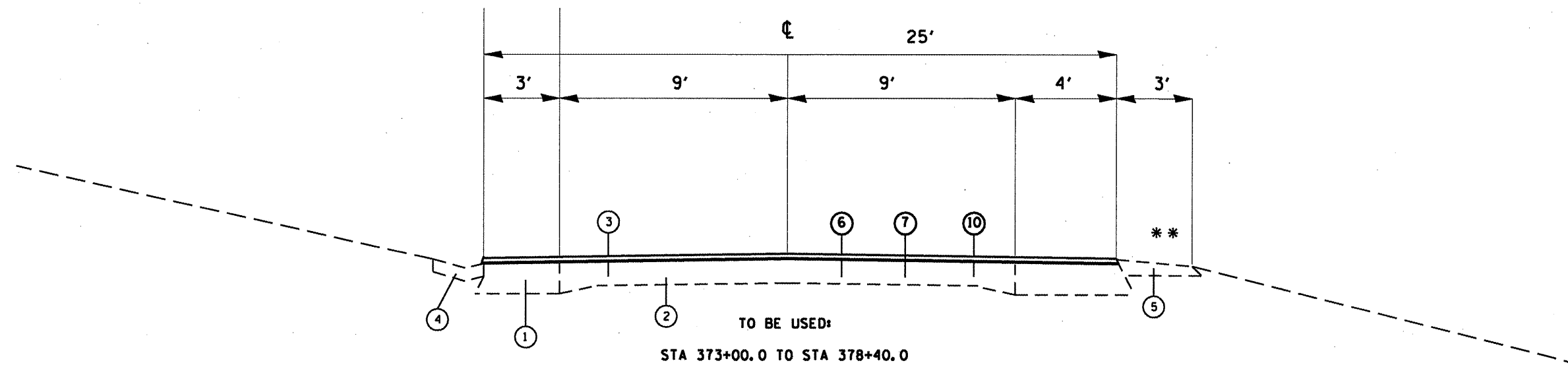

TO BE USED:
STA 373+00.0 TO STA 378+40.0

**

FILE NAME =	USER NAME = sheperdgd	DESIGNED -	REVISED -	STATE OF ILLINOIS DEPARTMENT OF TRANSPORTATION	TYPICAL SECTIONS	F.A.P. RTE.	SECTION	COUNTY	TOTAL SHEETS	SHEET NO.
328	109RS-2	WHITE	15			6				
SCALE: _____ SHEET NO. 6 OF 14 SHEETS STA. _____ TO STA. _____						CONTRACT NO. 78066				
						FED. ROAD DIST. NO. ILLINOIS FED. AID PROJECT				

TYPICAL SECTION #5

WHITE COUNTY
 FAP 328 (US 45)
 LOOKING IN DIRECTION OF INCREASING STATIONING)

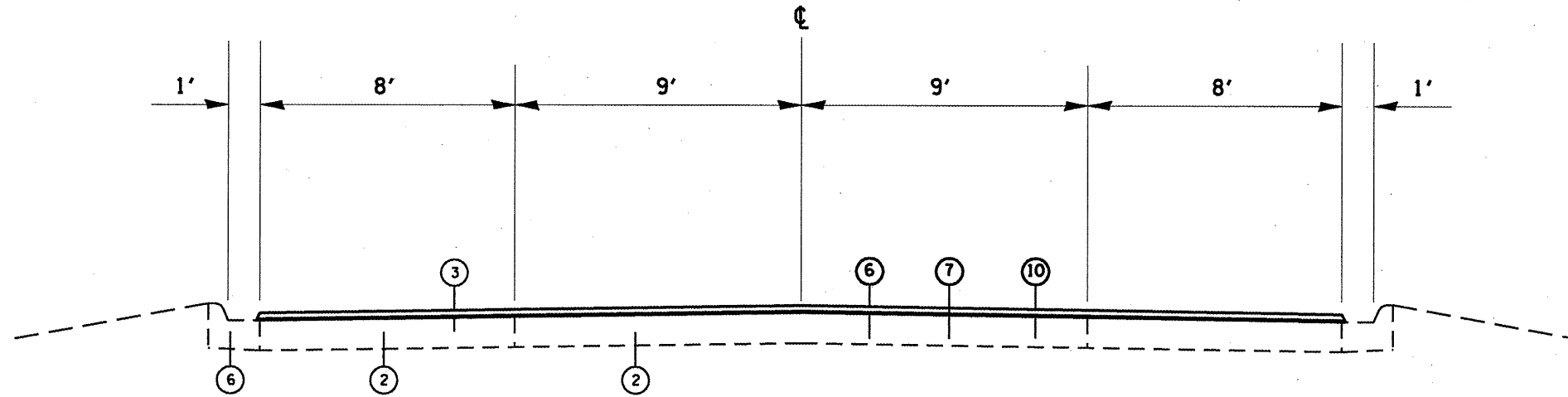

TO BE USED:
 STA 378+40.0 TO STA 381+90.0

- ① EXISTING BASE COURSE WIDENING, 9"
- ② EXISTING PAVEMENT STRUCTURE
- ③ EXISTING HOT MIX ASPHALT RESURFACING, 3 1/2" TYP.
- ④ EXISTING CONCRETE GUTTER, TYPE B (MODIFIED)
- ⑤ EXISTING AGGREGATE SHOULDERS

- ⑦ PROPOSED HMA LEVELING BINDER, 3/4"
- ⑧ PROPOSED AGGREGATE SHOULDERS, 1 1/4"
- ⑨ PROPOSED HMA SURFACE REMOVAL, 1"
- ⑩ PROPOSED HMA SURFACE REMOVAL, 2 1/4"
- ⑪ PROPOSED AGGREGATE SHOULDERS, 1 1/4"
- ⑫ PROPOSED BITUMINOUS SHOULDERS SUPERPAVE 4 1/2" TO 2" MIN
- ⑬ PROPOSED BITUMINOUS SHOULDERS SUPERPAVE 4 1/2" TO 2" MIN

NOTES:

** MATCH EXISTING SHOULDER SLOPE UP TO 6% MAXIMUM.

FILE NAME =	USER NAME = shepardgd	DESIGNED - ---	REVISED - ---	STATE OF ILLINOIS DEPARTMENT OF TRANSPORTATION	TYPICAL SECTIONS			F.A.P. RTE.	SECTION	COUNTY	TOTAL SHEETS	SHEET NO.
at\pwwork\pwwidot\shepardgd\dms45876\d	78066_sht_misc.dgn	DRAWN - ---	REVISED - ---		SCALE: _____	SHEET NO. 5 OF 14 SHEETS	STA. _____ TO STA. _____	328	109RS-2	WHITE	15	7
	PLOT SCALE = 100.0000 1 / IN.	CHECKED - ---	REVISED - ---					CONTRACT NO. 78066				
	PLOT DATE = 12/4/2008	DATE - -----	REVISED - ---					ILLINOIS FED. AID PROJECT				

SIDEROAD AND ENTRANCE SCHEDULE

ENTRANCE TYPE	RT/LT	EXISTING SURFACE TYPE	HMA SURF. REM. BT. JT. •	BIT. MAT. PRIME COAT •	AGG. PRIME COAT •	INCIDENTAL BIT. SURFACE	PCC SURF. REM. BT. JT.	AGGREGATE BASE COURSE TYPE B-8" •		
			(SQ YD)	(GAL)	(TON)	(TON)	(SQ YD)	(SQ YD)		
ALONG FAP 328 (US 45)										
RURAL SECTION										
CE	RT	BIT		2.0	0.0	1.1				
CE	RT	BIT		1.6	0.0	0.8				
CE	RT	BIT		3.8	0.1	2.1				
PE	RT	AGG		8.0	0.0	1.7				
PE	RT	BIT		0.8	0.0	0.5				
1350 N	LT	BIT	64.2	5.8	0.1	10.8		64.2		
PE	LT	AGG		3.0	0.0	0.7				
PE	RT	AGG		3.0	0.0	0.7				
PE	RT	AGG		13.7	0.1	3.0				
1200 N	LT	O & C	56.7	5.1	0.1	9.5		56.7		
1200 N	RT	CONC		8.8	0.1	8.2	97.3			
PE	LT	AGG		3.0	0.0	0.7				
PE	LT	AGG		6.5	0.0	1.4				
PE	RT	AGG		6.5	0.0	1.4				
PE	RT	AGG		3.7	0.0	0.8				
1100 N	LT	O & C	102.5	9.2	0.2	17.2		102.5		
PE	LT	AGG		3.0	0.0	0.7				
PE	LT	AGG		4.4	0.0	1.0				
PE	RT	AGG		5.8	0.0	1.3				
PE	LT	AGG		5.4	0.0	1.2				
PE	LT	AGG		6.5	0.0	1.4				
1100 N	LT	BIT	45.0	4.1	0.1	7.6		45.0		
1100 N	RT	AGG		13.9	0.1	7.3		43.3		
900 N	LT	BIT	45.8	4.1	0.1	7.7		45.8		
900 N	RT	BIT	50.8	4.6	0.1	8.5		50.8		
PE	RT	AGG		3.0	0.0	0.7				
825 N	LT	O & C	63.3	5.7	0.1	10.6		63.3		
PE	LT	AGG		3.7	0.0	0.8				
PE	RT	AGG		3.0	0.0	0.7				
PE	RT	AGG		3.0	0.0	0.7				
PE	LT	AGG		3.0	0.0	0.7				
PE	LT	AGG		3.0	0.0	0.7				
PE	LT	AGG		3.0	0.0	0.7				
PE	RT	AGG		3.0	0.0	0.7				
PE	RT	AGG		3.0	0.0	0.7				
PE	LT	CONC		0.9	0.0	0.5				
PE	LT	O & C		0.5	0.0	0.3				
CE	LT	AGG		3.0	0.0	0.7				
PE	RT	AGG		3.0	0.0	0.7				
PE	RT	AGG		3.0	0.0	0.7				
CE	LT	AGG		8.7	0.0	1.9				
PE	RT	AGG		3.0	0.0	0.7				
CE	LT	AGG		8.0	0.0	1.7				
750 N	RT	O & C	72.5	6.5	0.1	12.2		72.5		
CE	RT	AGG		13.7	0.1	3.0				
PE	RT	AGG		3.0	0.0	0.7				
PE	LT	AGG		3.0	0.0	0.7				
RURAL SECTION TOTAL			501	229	2	138	98	545		

•SEE PAVEMENT AND SHOULDER SCHEDULE FOR ADDITIONAL QUANTITIES.

PAVEMENT AND SHOULDER SCHEDULE

LOCATION STATION TO STATION	TYPICAL NUMBER	HOT-MIX ASPHALT LEVELING BINDER TON	HOT-MIX ASPHALT SURFACE COURSE TON	PRIME COAT*		AGGREGATE SHOULDERS, TYPE B TONS	HOT-MIX ASPHALT SURFACE REMOVAL, 1" SO YD	HOT-MIX ASPHALT SURFACE REMOVAL, 1-1/2" SO YD	HOT-MIX ASPHALT SURFACE REMOVAL, 2-1/4" SO YD	HOT-MIX ASPHALT SURFACE REMOVAL BUTT JOINT* SO YD	TEMPORARY RAMP* SO YD	AGGREGATE BASE COURSE TYPE B-8" SO YD
				BITUMINOUS MATERIALS GAL	AGGREGATE TON							
RURAL SECTION												
+60.0 TO 74+16.0	1	892.7	1793.9	2762.6	63.8	907.6	21250.7			72.2	14.4	
74+16.0 TO 75+24.0	1	13.1	26.3	40.6	0.9	13.3	312.0					
75+24.0 TO 163+35.9	1	1069.3	2149.0	3309.4	76.4	1087.2	25456.6					
163+35.9 TO 163+39.7	STA EQN											
163+39.7 TO 174+00.0	1	128.7	258.6	398.2	9.2	130.8	3063.1			28.9		
174+00.0 TO 174+35.3	2	4.0	7.9	12.2	0.1				94.1			
174+35.3 TO 174+53.5	STA EQN											
174+53.5 TO 188+90.0	2	160.9	321.8	498.0	5.7			3830.7				
188+90.0 TO 193+82.0	1	59.7	120.0	184.8	4.3	60.7	1421.3			72.2	14.4	
193+82.0 TO 194+24.0	GAP 097-2007											
194+24.0 TO 238+92.8	1	542.3	1089.8	1678.3	38.7	551.4	12909.9			43.3	14.4	
238+92.8 TO 238+95.9	STA EQN											
238+95.9 TO 277+14.2	1	463.4	931.2	1434.0	33.1	471.1	11030.6					
277+14.2 TO 277+69.1	STA EQN											
277+69.1 TO 303+08.5	1	308.2	619.3	953.7	22.0	313.3	7336.0					
303+08.5 TO 304+13.3	STA EQN											
304+13.3 TO 355+00.0	1	617.3	1240.5	1910.3	44.1	627.6	14694.9					
ENTRANCE AND SIDEROAD TOTALS				229.0	2.0					501.0		545.0
RURAL SECTION TOTALS		4260	8559	13411	301	4164	97476	3925		718	44	545
URBAN SECTION												
355+00.0 TO 373+00.0	3	218.4	439.0	676.0	15.6				5200.0	72.2		
373+00.0 TO 378+40.0	4	63.0	126.0	195.0	2.3				1500.0			
378+40.0 TO 381+90.0	5	55.5	111.1	171.9	2.0				1322.2		26.4	
URBAN SECTION TOTALS		337	677	1043	20				8023	73	27	
TOTALS		4597	9236	14454	321	4164	97476	3925	8023	791	71	545

*SEE SIDEROAD AND ENTRANCE SCHEDULE FOR ADDITIONAL QUANTITIES.

PAVEMENT MARKING SCHEDULE

STATION	LENGTH	PAINT PAVEMENT MARKING LINE, 4"				RAISED REFLECTIVE PAVEMENT MARKER	RAISED REFLECTIVE PAVEMENT MARKER REMOVAL	SHORT TERM PAVEMENT MARKING (3 APPL.)	TEMPORARY PAVEMENT MARKING	WORK ZONE PAVEMENT MARKING REMOVAL
		4" YELLOW SKIP DASH	4" YELLOW SKIP DASH & NO PASSING	4" DOUBLE SOLID YELLOW	4" WHITE EDGE LINES					
FAP 328 (US 45)	(FT)	(FT)	(FT)	(FT)	(FT)	(EACH)	(EACH)	(FT)	(FT)	(SQ FT)
+60.0 TO 21+64.8	2104.8	526.2			4209.6	26.3	26.3	574.0	4735.8	1578.6
21+64.8 TO 29+04.0	739.2		924.0		1478.4	9.2	9.2	201.6	2402.4	800.8
29+04.0 TO 32+20.8	316.8	79.2			633.6	4.0	4.0	86.4	712.8	237.6
32+20.8 TO 37+48.8	528.0		660.0		1056.0	6.6	6.6	144.0	1716.0	572.0
37+48.8 TO 40+65.6	316.8	79.2			633.6	4.0	4.0	86.4	712.8	237.6
40+65.6 TO 50+16.0	950.4		1188.0		1900.8	11.9	11.9	259.2	3088.8	1029.6
50+16.0 TO 52+80.0	264.0	66.0			528.0	3.3	3.3	72.0	594.0	198.0
52+80.0 TO 60+19.2	739.2		924.0		1478.4	9.2	9.2	201.6	2402.4	800.8
60+19.2 TO 79+72.8	1953.6	488.4			3907.2	24.4	24.4	532.8	4395.6	1465.2
79+72.8 TO 85+53.6	580.8		726.0		1161.6	7.3	7.3	158.4	1887.6	629.2
85+53.6 TO 89+76.0	422.4	105.6			844.8	5.3	5.3	115.2	950.4	316.8
89+76.0 TO 95+56.8	580.8		726.0		1161.6	7.3	7.3	158.4	1887.6	629.2
95+56.8 TO 123+02.4	2745.6	686.4			5491.2	34.3	34.3	748.8	6177.6	2059.2
123+02.4 TO 130+41.6	739.2		924.0		1478.4	9.2	9.2	201.6	2402.4	800.8
130+41.6 TO 133+05.6	264.0	66.0			528.0	3.3	3.3	72.0	594.0	198.0
133+05.6 TO 141+50.4	844.8		1056.0		1689.6	10.6	10.6	230.4	2745.6	915.2
141+50.4 TO 142+03.2	52.8	13.2			105.6	0.7	0.7	14.4	118.8	39.6
142+03.2 TO 152+59.2	1056.0		1320.0		2112.0	13.2	13.2	288.0	3432.0	1144.0
152+59.2 TO 153+12.0	52.8			105.6	105.6	0.7	0.7	14.4	211.2	70.4
153+12.0 TO 164+84.6	1168.8		1461.0		2337.6	14.6	14.6	318.8	3798.6	1266.2
164+84.6 TO 170+65.4	580.8	145.2			1161.6	7.3	7.3	158.4	1306.8	435.6
170+65.4 TO 180+34.0	950.4		1188.0		1900.8	11.9	11.9	259.2	3088.8	1029.6
180+34.0 TO 190+90.0	1056.0		1320.0		2112.0	13.2	13.2	288.0	3432.0	1144.0
190+90.0 TO 256+93.1	6600.0	1650.0			13200.0	82.5	82.5	1800.0	14850.0	4950.0
256+93.1 TO 265+37.9	844.8		1056.0		1689.6	10.6	10.6	230.4	2745.6	915.2
265+37.9 TO 270+65.9	528.0			1056.0	1056.0	6.6	6.6	144.0	2112.0	704.0
270+65.9 TO 281+76.8	1056.0		1320.0		2112.0	13.2	13.2	288.0	3432.0	1144.0
281+76.8 TO 291+80.0	1003.2		1254.0		2006.4	12.5	12.5	273.6	3260.4	1086.8
291+80.0 TO 296+55.2	475.2	118.8		950.4	950.4	5.9	5.9	129.6	2019.6	673.2
296+55.2 TO 307+63.2	1003.2		1254.0		2006.4	12.5	12.5	273.6	3260.4	1086.8
307+63.2 TO 315+55.2	792.0	198.0			1584.0	9.9	9.9	216.0	1782.0	594.0
315+55.2 TO 321+88.8	633.6		792.0		1267.2	7.9	7.9	172.8	2059.2	686.4
321+88.8 TO 325+58.4	369.6	92.4			739.2	4.6	4.6	100.8	831.6	277.2
325+58.4 TO 334+03.2	844.8		1056.0		1689.6	10.6	10.6	230.4	2745.6	915.2
334+03.2 TO 355+00.0	2096.8	524.2			4193.6	26.2	26.2	571.9	4717.8	1572.6
SUBTOTAL - RURAL SECTION			26100		70511	441	441	9616	96611	32204
355+00.0 TO 381+53.0	2653.0	663.3			5306.0	33.2	33.2	1360.3	5969.3	1989.8
SUBTOTAL - URBAN SECTION			664		5306	34	34	1361	5970	1990
TOTALS			102581			475	475	10977	102581	34194

RUMBLE STRIP SCHEDULE

STATION	LENGTH	RUMBLE STRIP
FAP 328 (US 45)	(FT)	(SQ FT)
3+13.0 TO 3+31.0	18.0	234.0
3+76.0 TO 3+94.0	18.0	234.0
10+75.0 TO 11+03.0	28.0	364.0
12+02.0 TO 12+30.0	28.0	364.0
TOTALS		1196

PATCHING SCHEDULE

NORTHBOUND LANE

LOCATION MILEPOST	LENGTH (FT)	WIDTH (FT)	AREA (SQ YD)	TYPE	TIE BARS
RURAL					
0	6	13	8.7	II	
0	4	13	5.8	II	
0.1					
0.2	6	13	8.7	II	
0.2	12	13	17.3	III	
0.2	8	13	11.6	II	
0.3	6	13	8.7	II	
0.3					
0.3					
0.3	8	13	11.6	II	
0.4	8	13	11.6	II	
0.4	10	13	14.4	II	
0.4	6	13	8.7	II	
0.5	8	13	11.6	II	
0.5	6	13	8.7	II	
0.5	6	13	8.7	II	
0.5					
0.5					
0.6	6	13	8.7	II	
0.6					
0.7	14	13	20.2	III	
0.7	4	13	5.8	II	
0.7	6	13	8.7	II	
0.7	10	13	14.4	II	
0.8	12	13	17.3	III	
0.8	10	13	14.4	II	
0.8	14	13	20.2	III	
0.8	6	13	8.7	II	
0.9	6	13	8.7	II	
SHEET TOTALS:			262.9		0

SOUTHBOUND LANE

LOCATION MILEPOST	LENGTH (FT)	WIDTH (FT)	AREA (SQ YD)	TYPE	TIE BARS
RURAL					
0.0	4	13	5.8	II	
0.0	6	13	8.7	II	
0.1	6	13	8.7	II	
0.2	12	13	17.3	III	
0.2	13	13	18.8	III	
0.2					
0.3	6	13	8.7	II	
0.3	9	13	13.0	II	
0.3	11	13	15.9	III	
0.4	6	13	8.7	II	
0.4	16	13	23.1	III	
0.4	25	13	36.1	IV	14
0.4	10	13	14.4	II	
0.5	14	13	20.2	III	
0.5	10	13	14.4	II	
0.5	6	13	8.7	II	
0.5	25	13	36.1	IV	14
0.5	10	13	14.4	II	
0.6	6	13	8.7	II	
0.6	6	13	8.7	II	
0.7	10	13	14.4	II	
0.7	13	13	18.8	III	
0.7	6	13	8.7	II	
0.7	12	13	17.3	III	
0.8	6	13	8.7	II	
0.8	6	13	8.7	II	
0.8	12	13	17.3	III	
0.8					
0.9	8	13	11.6	II	
SHEET TOTALS:			396		28

NORTHBOUND LANE

LOCATION MILEPOST	LENGTH (FT)	WIDTH (FT)	AREA (SQ YD)	TYPE	TIE BARS
RURAL					
0.9	8	13	11.6	II	
0.9	10	13	14.4	II	
0.9	6	13	8.7	II	
0.9	8	13	11.6	II	
0.9	6	13	8.7	II	
1	9	13	13.0	II	
1	8	13	11.6	II	
1	6	13	8.7	II	
1	8	13	11.6	II	
1	10	13	14.4	II	
1.1	10	13	14.4	II	
1.1	8	13	11.6	II	
1.1	9	13	13.0	II	
1.1	25	13	36.1	IV	14
1.2	10	13	14.4	II	
1.2	6	13	8.7	II	
1.2	10	13	14.4	II	
1.2	10	13	14.4	II	
1.3	6	13	8.7	II	
1.3	8	13	11.6	II	
1.4	4	13	5.8	II	
1.4	20	13	28.9	IV	
1.4					
1.4					
1.5	8	13	11.6	II	
1.5	8	13	11.6	II	
1.5	4	13	5.8	II	
1.5					
1.6	10	13	14.4	II	
SHEET TOTALS:			339		14

SOUTHBOUND LANE

LOCATION MILEPOST	LENGTH (FT)	WIDTH (FT)	AREA (SQ YD)	TYPE	TIE BARS
RURAL					
0.9	6	13	8.7	II	
0.9	8	13	11.6	II	
0.9	6	13	8.7	II	
0.9	8	13	11.6	II	
0.9					
1.0	8	13	11.6	II	
1.0	8	13	11.6	II	
1.0					
1.0					
1.1	10	13	14.4	II	
1.1	8	13	11.6	II	
1.1	6	13	8.7	II	
1.1					
1.2	10	13	14.4	II	
1.2	6	13	8.7	II	
1.2	8	13	11.6	II	
1.2					
1.3	6	13	8.7	II	
1.3					
1.4	10	13	14.4	II	
1.4	20	13	28.9	IV	
1.4	6	13	8.7	II	
1.4	25	13	36.1	IV	14
1.5	10	13	14.4	II	
1.5	12	13	17.3	III	
1.5	4	13	5.8	II	
1.5	6	13	8.7	II	
1.6	25	13	36.1	IV	14
SHEET TOTALS:			312.0		28

• MILEPOST BEGINS AT THE NORTH PROJECT TERMINUS AND GOES SOUTH.
 PATCHING SURVEY QUANTITIES FOR INFORMATION ONLY. ACTUAL QUANTITIES AND LOCATIONS SHALL BE DETERMINED BY ENGINEER IN FIELD.

PATCHING SCHEDULE (CONT)

NORTHBOUND LANE

LOCATION MILEPOST*	LENGTH (FT)	WIDTH (FT)	AREA (SQ YD)	TYPE	TIE BARS
RURAL					
1.6	6	13	8.7	II	
1.7	6	13	8.7	II	
1.7	6	13	8.7	II	
1.7	12	13	17.3	III	
1.8	6	13	8.7	II	
1.8	25	13	36.1	IV	14
1.9	12	13	17.3	III	
1.9	6	13	8.7	II	
2	10	13	14.4	II	
2	8	13	11.6	II	
2	6	13	8.7	II	
2	10	13	14.4	II	
2					
2					
2.1	10	13	14.4	II	
2.1	4	13	5.8	II	
2.1	8	5	4.4	I	
2.1	10	13	14.4	II	
2.1	8	13	11.6	II	
2.2	8	13	11.6	II	
2.2	15	13	21.7	III	
2.2	6	13	8.7	II	
2.2	10	13	14.4	II	
2.3	6	13	8.7	II	
2.3	20	13	28.9	IV	
2.3	8	13	11.6	II	
2.3					
2.4	6	13	8.7	II	
2.4	8	13	11.6	II	
2.4	10	13	14.4	II	
2.4	10	13	14.4	II	
2.4					
2.5	8	13	11.6	II	
2.5	8	13	11.6	II	
2.5	6	13	8.7	II	
2.5	6	13	8.7	II	
2.5					
2.6	10	13	14.4	II	
2.6	8	13	11.6	II	
2.6	6	13	8.7	II	
2.7	6	13	8.7	II	
2.7	4	13	5.8	II	
2.8	6	13	8.7	II	
2.8					
2.9	4	13	5.8	II	
3.1	6	13	8.7	II	
3.1	6	13	8.7	II	
3.1					
3.2	6	13	8.7	II	
3.2					
3.2					
3.3	6	13	8.7	II	
3.4	4	13	5.8	II	
3.4	400	5	222.2	IV	201
3.5	8	13	11.6	II	
3.5	8	13	11.6	II	
3.5					
3.6	6	13	8.7	II	
3.6	6	13	8.7	II	
3.6	10	13	14.4	II	
3.6					
3.6					
3.6					
3.7	6	13	8.7	II	
3.7	25	13	36.1	IV	14
SHEET TOTALS:			834.8		229.0

SOUTHBOUND LANE

LOCATION MILEPOST*	LENGTH (FT)	WIDTH (FT)	AREA (SQ YD)	TYPE	TIE BARS
RURAL					
1.6					
1.7	6	13	8.7	II	
1.7	10	13	14.4	II	
1.7	12	13	17.3	III	
1.8	8	13	11.6	II	
1.8	20	13	28.9	IV	
1.9	6	13	8.7	II	
1.9	12	13	17.3	III	
2.0	8	13	11.6	II	
2.0	6	13	8.7	II	
2.0	6	13	8.7	II	
2.0	20	13	28.9	IV	
2.0	6	13	8.7	II	
2.0	6	13	8.7	II	
2.0	14	13	20.2	III	
2.1	12	13	17.3	III	
2.1	10	13	14.4	II	
2.1	8	13	11.6	II	
2.1	8	13	11.6	II	
2.1	8	13	11.6	II	
2.2	8	13	11.6	II	
2.2	6	13	8.7	II	
2.2	6	13	8.7	II	
2.2	10	13	14.4	II	
2.3	8	13	11.6	II	
2.3	20	13	28.9	IV	
2.3	8	13	11.6	II	
2.3	6	13	8.7	II	
2.4	10	13	14.4	II	
2.4	10	13	14.4	II	
2.4	15	13	21.7	III	
2.4	25	13	36.1	IV	14
2.4	10	13	14.4	II	
2.5	8	13	11.6	II	
2.5	8	13	11.6	II	
2.5	6	13	8.7	II	
2.5	8	13	11.6	II	
2.5	6	13	8.7	II	
2.5	10	13	14.4	II	
2.6	6	13	8.7	II	
2.7	4	13	5.8	II	
2.8	10	13	14.4	II	
2.8	6	13	8.7	II	
2.9	6	13	8.7	II	
3.1	10	13	14.4	II	
3.1	8	13	11.6	II	
3.1	4	13	5.8	II	
3.2	6	13	8.7	II	
3.2	14	13	20.2	III	
3.2	6	13	8.7	II	
3.3					
3.4	4	13	5.8	II	
3.5	8	13	11.6	II	
3.5	10	13	14.4	II	
3.5	6	13	8.7	II	
3.6	8	13	11.6	II	
3.6	6	13	8.7	II	
3.6	6	13	8.7	II	
3.6	10	13	14.4	II	
3.6	6	13	8.7	II	
3.7	8	13	11.6	II	
3.7	25	13	36.1	IV	14
SHEET TOTALS:			807.4		28.0

NORTHBOUND LANE

LOCATION MILEPOST*	LENGTH (FT)	WIDTH (FT)	AREA (SQ YD)	TYPE	TIE BARS
RURAL					
3.7	20	13	28.9	IV	
3.8	4	13	5.8	II	
3.8	8	13	11.6	II	
3.8	12	13	17.3	III	
3.8	6	13	8.7	II	
3.9	12	13	17.3	III	
3.9	4	13	5.8	II	
3.9					
4.1	12	13	17.3	III	
4.1					
4.2	15	13	21.7	III	
4.2					
4.2					
4.3	4	13	5.8	II	
4.4	6	13	8.7	II	
4.4	6	13	8.7	II	
4.4	8	13	11.6	II	
4.5	10	13	14.4	II	
4.5	8	13	11.6	II	
4.5	6	13	8.7	II	
4.5	8	13	11.6	II	
4.6	6	13	8.7	II	
4.6	8	13	11.6	II	
4.6	12	13	17.3	III	
4.6	15	13	21.7	III	
4.7	15	13	21.7	III	
4.7	15	13	21.7	III	
4.7	6	13	8.7	II	
4.7	10	13	14.4	II	
4.8	8	13	11.6	II	
4.8	6	13	8.7	II	
4.8	6	13	8.7	II	
5.1	10	13	14.4	II	
5.2					
5.2					
5.3	4	13	5.8	II	
5.3					
5.4					
5.5	8	13	11.6	II	
5.5	6	13	8.7	II	
5.6	10	13	14.4	II	
5.6	6	13	8.7	II	
5.6					
5.7	6	13	8.7	II	
5.7	15	13	21.7	III	
5.7	15	13	21.7	III	
5.8	8	13	11.6	II	
5.8	6	13	8.7	II	
5.9	6	13	8.7	II	
5.9	10	13	14.4	II	
6	8	13	11.6	II	
6	6	13	8.7	II	
6	25	5	13.9	II	14
6.1	10	13	14.4	II	
6.2	6	13	8.7	II	
6.2					
URBAN					
6.6	6	13	8.7	II	
6.6	4	13	5.8	II	
6.7	6	13	8.7	II	
6.7	10	13	14.4	II	
6.7	6	13	8.7	II	
6.8	15	13	21.7	III	
6.8	8	13	11.6	II	
6.9	10	13	14.4	II	
6.9	10	13	14.4	II	
6.9	50	5	27.8	IV	26
7	4	13	5.8	II	
RURAL SHEET TOTALS:			585.9		14.0
URBAN SHEET TOTALS:			141.9		26.0
RURAL JOB TOTALS:			2023.0		257.0
URBAN JOB TOTALS:			141.9		26.0

SOUTHBOUND LANE

LOCATION MILEPOST*	LENGTH (FT)	WIDTH (FT)	AREA (SQ YD)	TYPE	TIE BARS
RURAL					
3.7					
3.8	8	13	11.6	II	
3.8	25	13	36.1	IV	14
3.8	15	13	21.7	III	
3.8	20	13	28.9	IV	
3.9	6	13	8.7	II	
3.9	25	13	36.1	IV	14
3.9	6	13	8.7	II	
4.1	6	13	8.7	II	
4.1	25	13	36.1	IV	14
4.2	10	13	14.4	II	
4.2	8	13	11.6	II	
4.2	6	13	8.7	II	
4.3	4	13	5.8	II	
4.4	6	13	8.7	II	
4.4	6	13	8.7	II	
4.4					
4.5	15	13	21.7	III	
4.5	6	13	8.7	II	
4.5					
4.6	6	13	8.7	II	
4.6	8	13	11.6	II	
4.6	10	13	14.4	II	
4.6					
4.7	15	13	21.7	III	
4.7	15	13	21.7	III	
4.7	25	13	36.1	IV	14
4.7	15	13	21.7	III	
4.8	20	13	28.9	IV	
4.8	6	13	8.7	II	
4.8					
5.1	6	13	8.7	II	
5.2	6	13	8.7	II	
5.2	12	13	17.3	III	
5.3	4	5	2.2	I	
5.3	4	13	5.8	II	
5.4	15	13	21.7	III	
5.5	6	13	8.7	II	
5.5					
5.6	8	13	11.6	II	
5.6	10	13	14.4	II	
5.6	6	13	8.7	II	
5.7	6	13	8.7	II	
5.7					
5.8	8	13	11.6	II	
5.8					
5.9	6	13	8.7	II	
5.9	12	13	17.3	III	
6.0	6	13	8.7	II	
6.0					
6.0					
6.1					
6.2	6	13	8.7	II	
6.2	12	13	17.3	III	
URBAN					
6.6	6	13	8.7	II	
6.6	4	13	5.8	II	
6.7	6	13	8.7	II	
6.7					
6.8	25	13	36.1	IV	14
6.8	8	13	11.6	II	
6.9	6	13	8.7	II	
6.9	10	13	14.4	II	
6.9	6	13	8.7	II	
7.0	4	13	5.8	II	
RURAL SHEET TOTALS:			646.4		56.0
URBAN SHEET TOTALS:			108.3		

BUTT JOINT

STA. 0+60 TO STA. 0+85

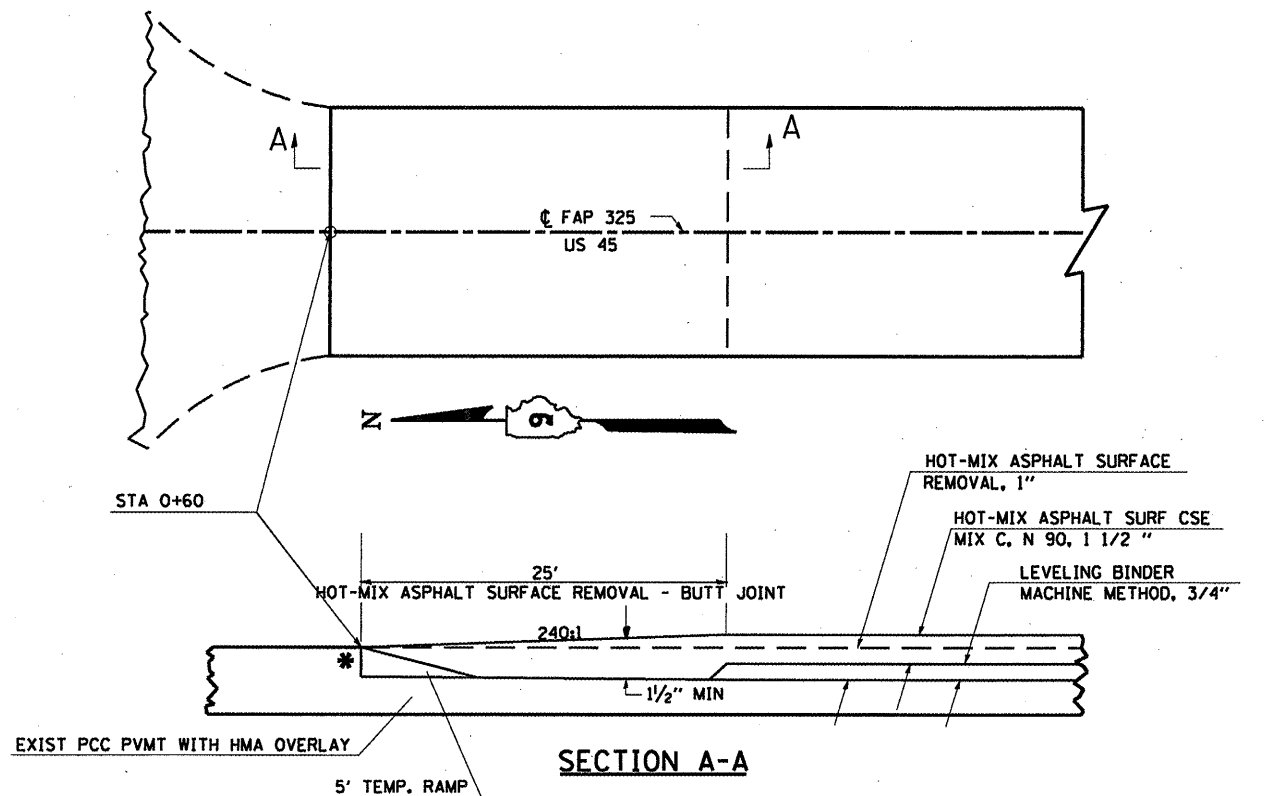

SECTION A-A

*SAW CUT SHALL BE INCLUDED IN THE COST OF HMA SURFACE REMOVAL.

BUTT JOINT

STA. 381+75 TO STA. 381+90

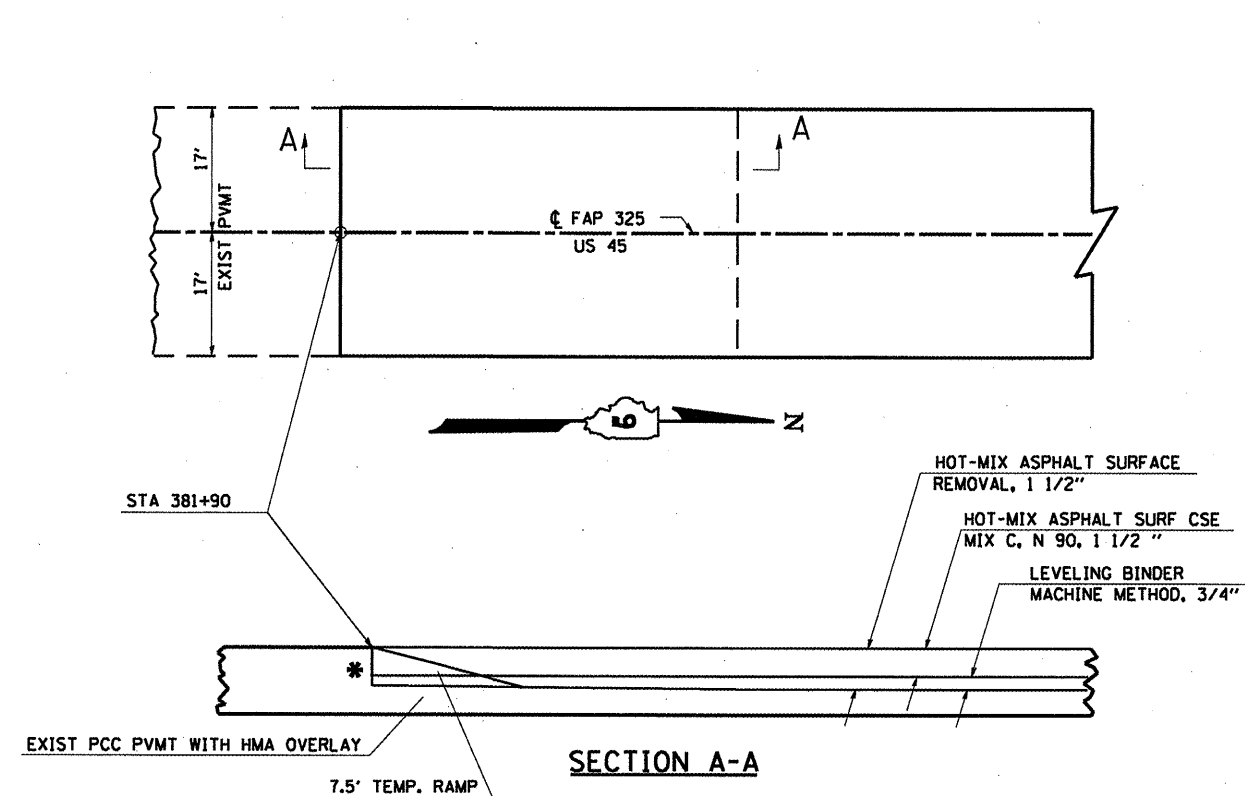

SECTION A-A

*SAW CUT SHALL BE INCLUDED IN THE COST OF HMA SURFACE REMOVAL.

PAVEMENT TRANSITION DETAIL

STA. 355+00 TO STA. 355+25

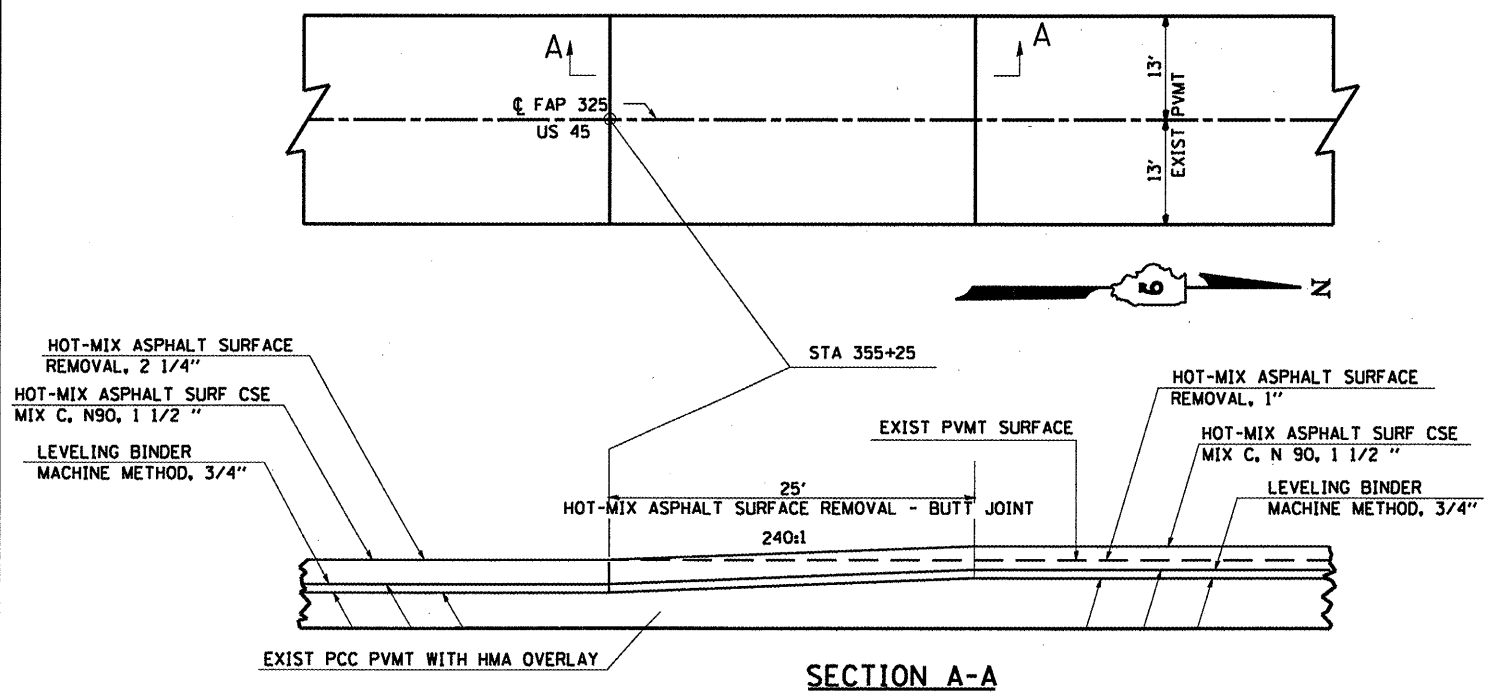

SECTION A-A

PAVEMENT TRANSITION DETAIL

STA. 173+90 TO STA. 174+00

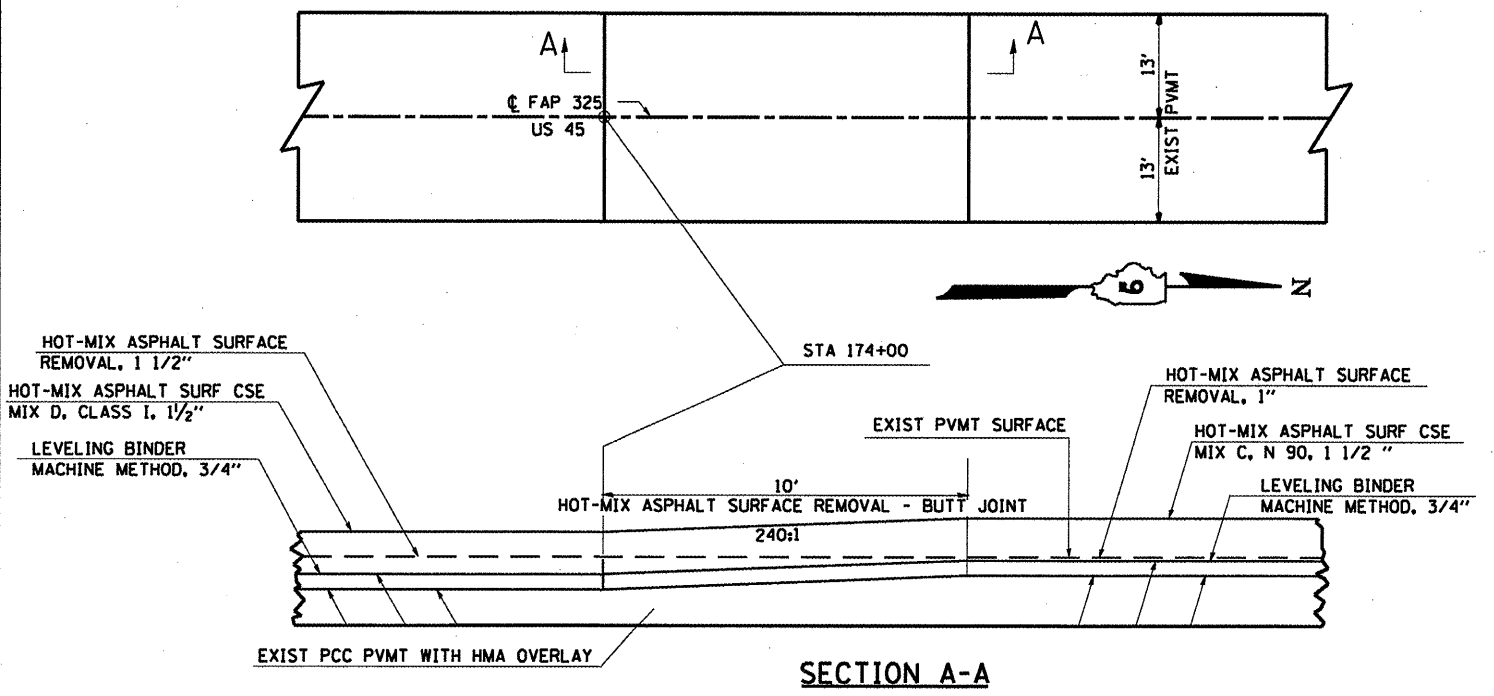

SECTION A-A

FILE NAME =	USER NAME = shepardgd	DESIGNED -	REVISED -
ct:\pw\work\pwsdot\shepardgd\dms49876\d78066_sht.msxdgn		DRAWN -	REVISED -
PLOT SCALE = 100.0000 1/16 IN.		CHECKED -	REVISED -
PLOT DATE = 12/4/2008		DATE -	REVISED -

STATE OF ILLINOIS
DEPARTMENT OF TRANSPORTATION

BUTT JOINT AND PAVEMENT TRANSITION DETAILS		F.A.P. RTE. 328	SECTION 109RS-2	COUNTY WHITE	TOTAL SHEETS 15	SHEET NO. 13
SCALE: _____	SHEET NO. 12 OF 14 SHEETS	STA. _____ TO STA. _____	FED. ROAD DIST. NO. _____ ILLINOIS FED. AID PROJECT			

PAVEMENT TRANSITION DETAIL

STA. 188+90 TO STA. 189+00

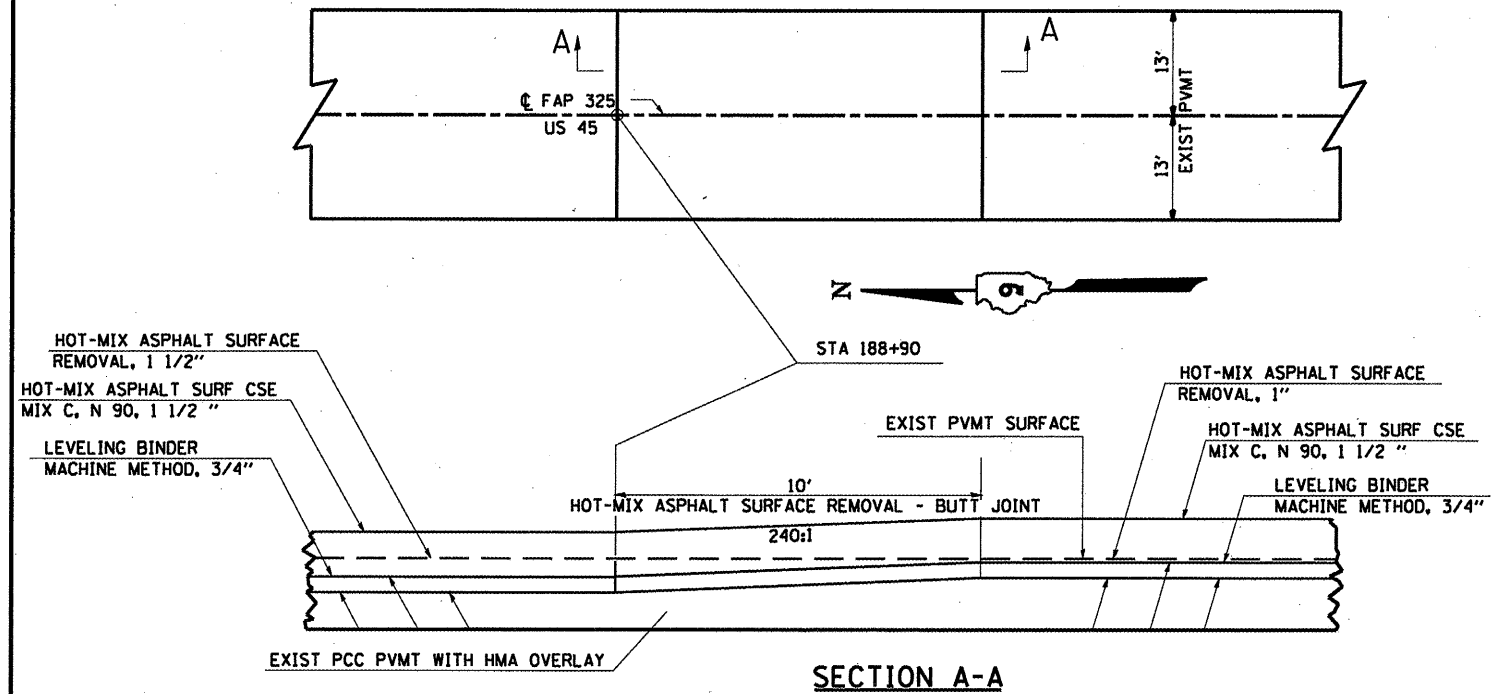

BUTT JOINT

FOR GAPPING STRUCTURE NUMBER 097-2007
STA. 193+67 TO STA. 193+82

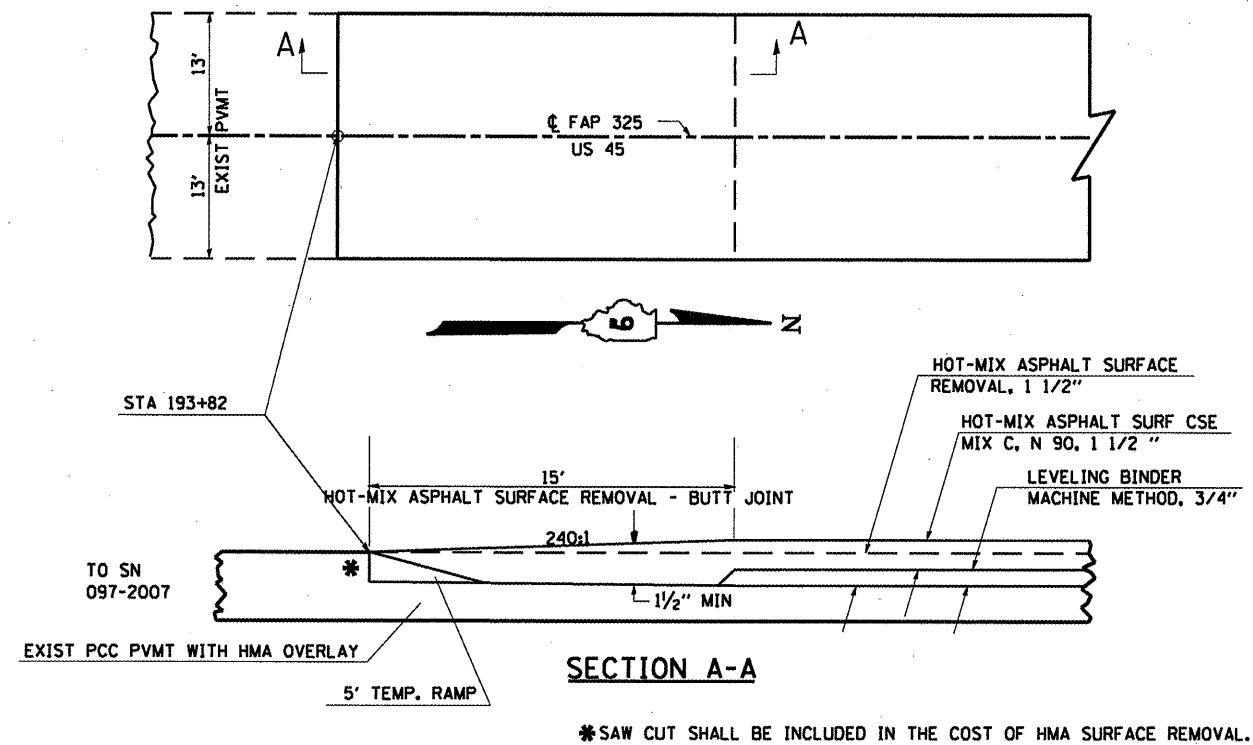

*SAW CUT SHALL BE INCLUDED IN THE COST OF HMA SURFACE REMOVAL.

RUMBLE STRIP DETAIL

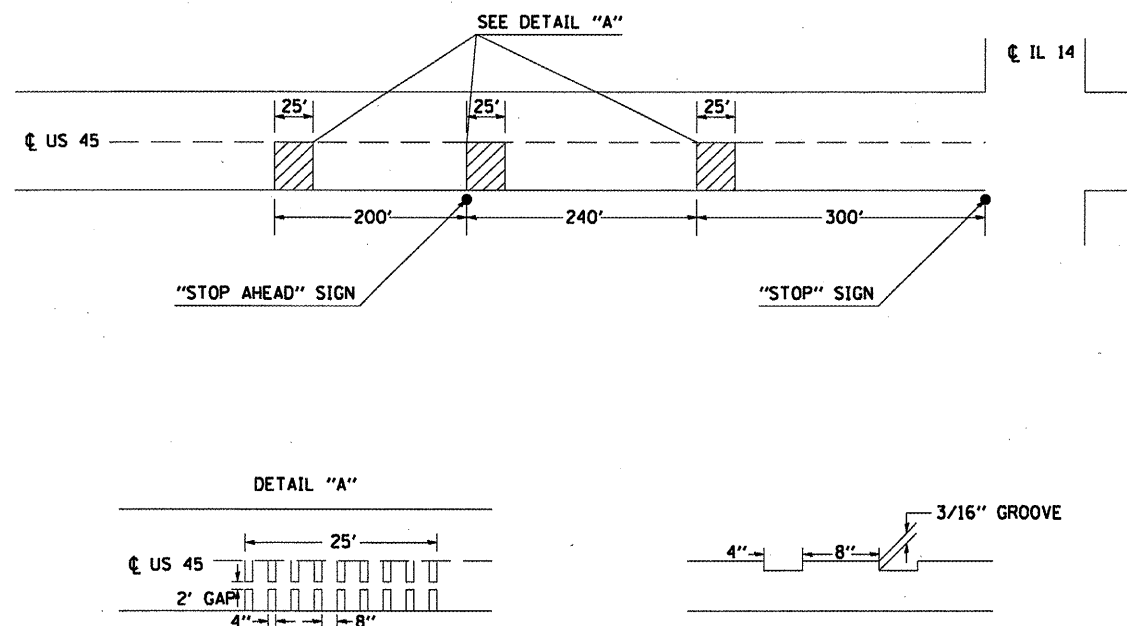

BUTT JOINT

FOR GAPPING STRUCTURE NUMBER 097-2007
STA. 194+24 TO STA. 194+39

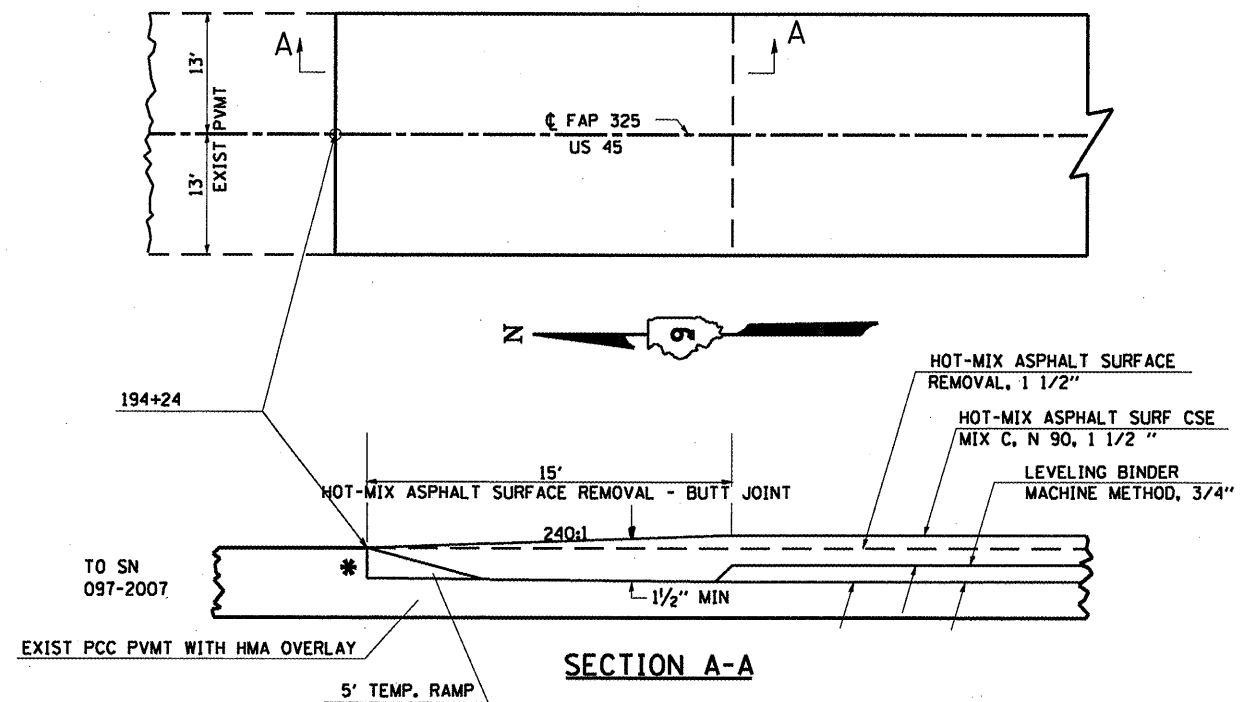

*SAW CUT SHALL BE INCLUDED IN THE COST OF HMA SURFACE REMOVAL.

FILE NAME =
c:\pwork\pwork\shepard\dms49876\d78066_sht_miso.dgn

USER NAME = shepardgd
DESIGNED -
DRAWN -
CHECKED -
DATE -
PLOT SCALE = 100.0000 / IN.
PLOT DATE = 12/4/2008

DESIGNED -
DRAWN -
CHECKED -
DATE -
REVISED -
REVISED -
REVISED -
REVISED -

STATE OF ILLINOIS
DEPARTMENT OF TRANSPORTATION

BUTT JOINT, PAVEMENT TRANSITION AND RUMBLE STRIP DETAILS

SCALE: SHEET NO. 13 OF 14 SHEETS STA. TO STA.

F.A.P. RTE.	SECTION	COUNTY	TOTAL SHEETS	SHEET NO.
328	109RS-2	WHITE	15	14
CONTRACT NO. 78066				
FED. ROAD DIST. NO. ILLINOIS FED. AID PROJECT				

DETAIL OF BITUMINOUS OR PCC
SIDE ROADS WITH BUTT JOINT

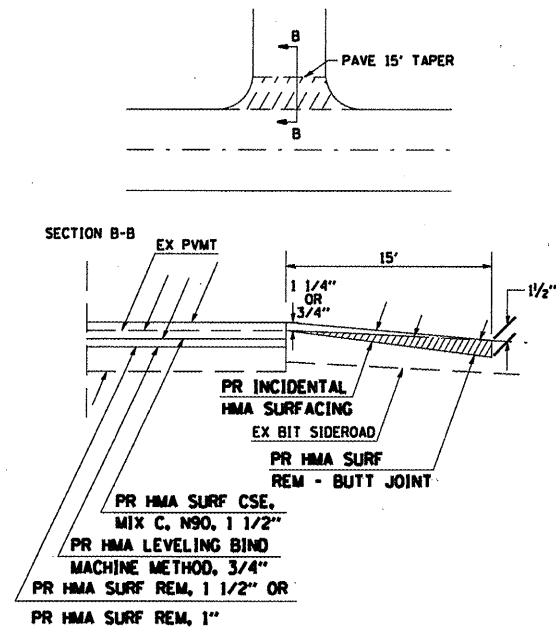

DETAIL OF OIL & CHIP
SIDE ROAD

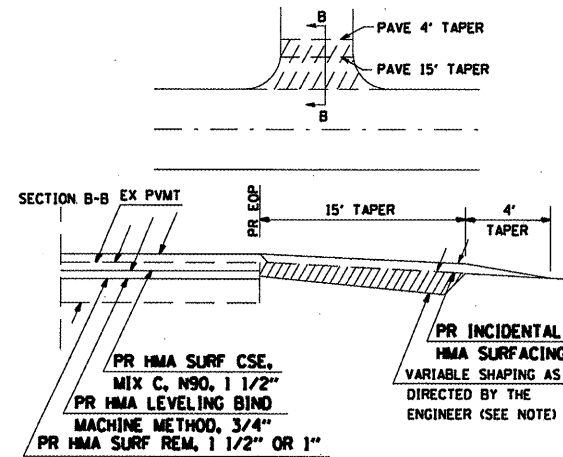

NOTES:
VARIABLE SHAPING IS INCLUDED IN THE COST OF HOT-MIX ASPHALT. PREPARATION OF EXISTING SURFACE AND ANY EXCAVATION FOR ENTRANCES SHALL BE IN ACCORDANCE WITH ARTICLE 406.09 OF THE STANDARD SPECIFICATIONS. IF EXISTING SUB-BASE IS INADEQUATE, AS DETERMINED BY THE ENGINEER, THE SIDEROADS SHALL BE CORED OUT AND AGGREGATE BASE COURSE TYPE B, 8" SHALL BE PLACED FOR BASE. THE COST OF CORING OUT THE SIDEROAD SHALL BE INCLUDED IN THE COST OF THE AGGREGATE BASE COURSE. IF EXISTING SUB-BASE IS DETERMINED TO BE ADEQUATE, THE AGGREGATE BASE COURSE SHALL BE DELETED AND THE PREPARATION OF THE BASE SHALL BE CONSTRUCTED ACCORDING TO ARTICLE 406.09.

DETAIL OF BITUMINOUS, PCC, OR OIL &
CHIP PRIVATE OR COMMERCIAL ENTRANCE

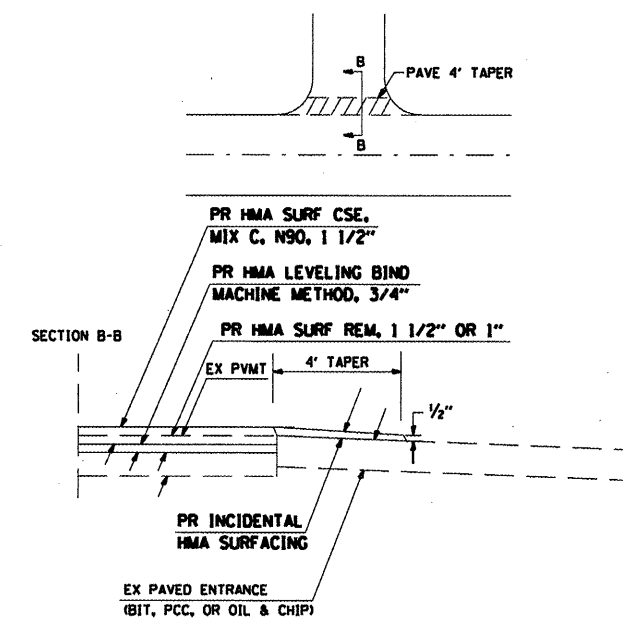

DETAIL OF AGGREGATE PRIVATE OR
COMMERCIAL ENTRANCE

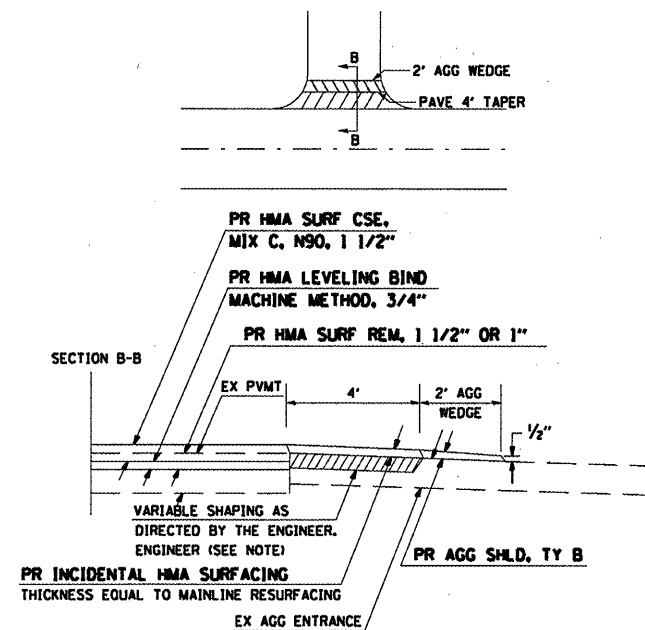

DETAIL OF AGGREGATE OR EARTH
FIELD ENTRANCE

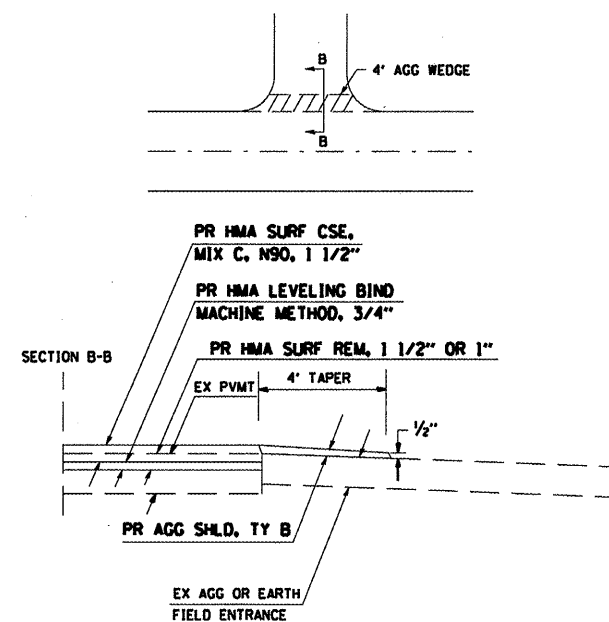

DETAIL OF AGGREGATE
SIDEROAD

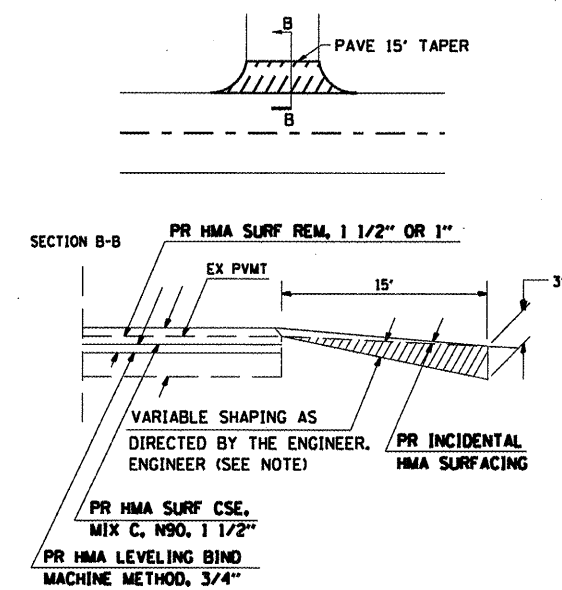

FILE NAME =
c:\pwwork\pwwork\shepardgd\dms49876\d78066_sht_miso.dgn

USER NAME = shepardgd
PLOT SCALE = 1/8" = 1' IN.
PLOT DATE = 12/4/2008

DESIGNED -
DRAWN -
CHECKED -
DATE -

REVISED -
REVISED -
REVISED -
REVISED -

STATE OF ILLINOIS
DEPARTMENT OF TRANSPORTATION

BUTT JOINT AND PAVEMENT TRANSITION DETAILS

SCALE: SHEET NO. 14 OF 14 SHEETS STA. TO STA.

F.A.P. RTE. 328	SECTION 109RS-2	COUNTY WHITE	TOTAL SHEETS 15	SHEET NO. 15
CONTRACT NO. 78066				
FED. ROAD DIST. NO. ILLINOIS FED. AID PROJECT				