

**NOTES:**  
 DETAIL NUMBERS INDICATE NO. OF CABLES.  
 TRENCHES WITH MORE THAN SEVEN CABLES SHALL BE INCREASED 3" IN WIDTH FOR EACH ADDITIONAL CABLE; IF SPECIFIED ON PLANS TWO PARALLEL TRENCHES MAY BE CONSTRUCTED.  
 DEPTH OF TRENCHES SHALL BE AS SHOWN ABOVE UNLESS OTHERWISE SPECIFIED ON THE PLANS.  
 ALL DISTURBED SURFACES SHALL BE RESTORED TO THEIR ORIGINAL CONDITION. COST IS INCIDENTAL TO TRENCH.

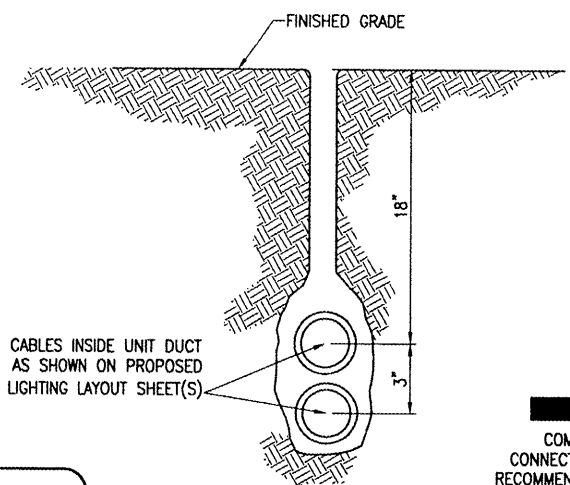

**PLOWED CABLE**  
(NOT TO SCALE)

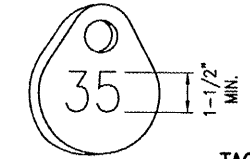

**TAG DETAIL**  
(NOT TO SCALE)

**NOTE:**  
 AFFIX NON-CORROSIVE TAG TO FIXTURE FACING RUNWAY WITH SET SCREW, WIRE TIE, OR METAL BAND. NUMERALS SHALL BE ENGRAVED FOR PERMANENT READABILITY.

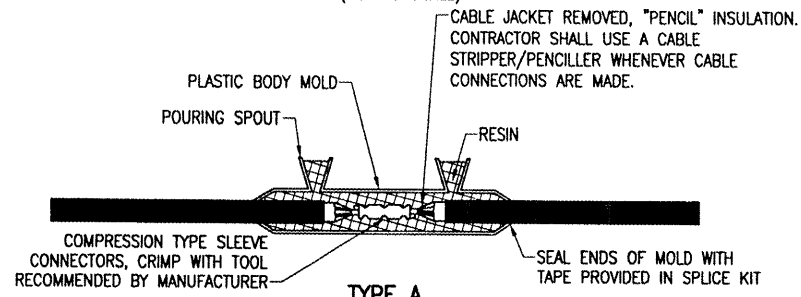

**TYPE A**

FOR SPLICES IN HOMERUNS FOR EXTENSIONS TO EXISTING CABLES ONLY

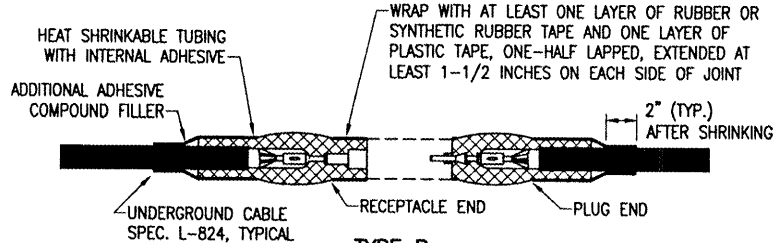

**TYPE B**

FOR SPLICES AT JUNCTION OF HOMERUN WITH LOOP CIRCUIT

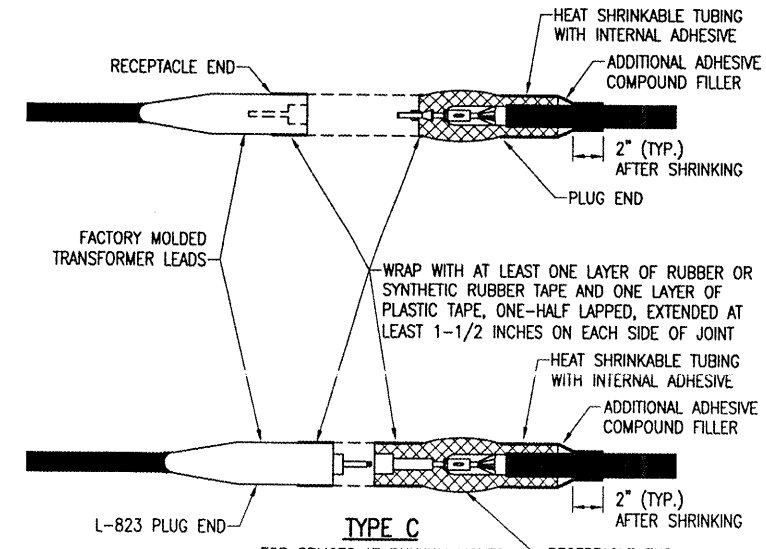

**TYPE C**

FOR SPLICES AT RUNWAY LIGHTS

**NOTES:**  
 SEE PROPOSED LIGHTING LAYOUT SHEET(S) FOR SPLICE TYPE.  
 INSIDE DIAMETER OF CONNECTOR SHALL PROPERLY MATCH THE OUTSIDE DIAMETER OF CABLE.

**CABLE SPLICES**  
(NOT TO SCALE)

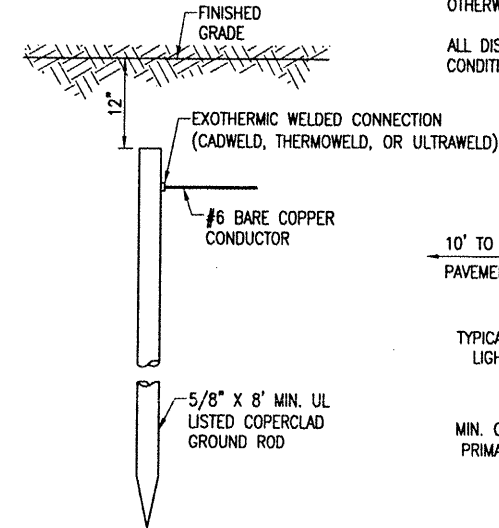

**CABLE TRENCHES**  
(NOT TO SCALE)

PER FAA AC 150/5340-30C DESIGN AND INSTALLATION DETAILS FOR AIRPORT VISUAL AIDS, A SAFETY GROUND MUST BE INSTALLED AT EACH LIGHT FIXTURE. A SAFETY GROUND SHALL BE INSTALLED AT EACH STAKE MOUNTED LIGHT AND EACH TRANSFORMER BASE/LIGHT CAN ASSOCIATED WITH RUNWAY LIGHTS, TAXIWAY LIGHTS, AND LIGHTED TAXI GUIDANCE SIGNS. THE SAFETY GROUND SHALL BE A #6 AWG BARE COPPER CONDUCTOR CONNECTED TO THE GROUND LUG ON THE RESPECTIVE L-867 TRANSFORMER BASE/LIGHT CAN OR MOUNTING STAKE AND A 5/8-INCH DIAMETER BY 8-FOOT LONG (MINIMUM) UL LISTED COPPER CLAD GROUND ROD.

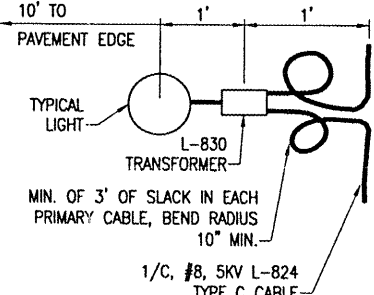

**PLAN VIEW**

**NOTES:**  
 SEE PROPOSED LIGHTING LAYOUT SHEET FOR LIGHT LOCATIONS.

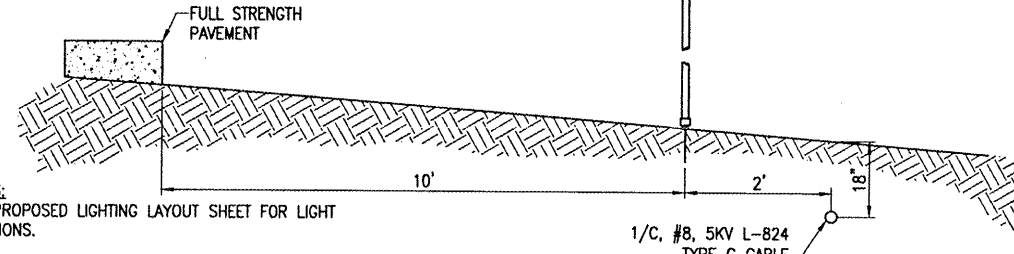

**PROFILE VIEW**

**LIGHT AND CABLE INSTALLATION DETAIL**  
(NOT TO SCALE)

**NOTES:**  
 TYPE AND MINIMUM NUMBER OF GROUND RODS SHALL BE AS SPECIFIED ON THE PLAN.  
 THE RESISTANCE TO GROUND OF THE GROUNDING SYSTEM SHALL NOT EXCEED 25 OHMS.  
 COST OF GROUND RODS IS INCIDENTAL TO THE ASSOCIATED ITEMS REQUIRING GROUNDING UNLESS OTHERWISE SPECIFIED.

**GROUND ROD**  
(NOT TO SCALE)

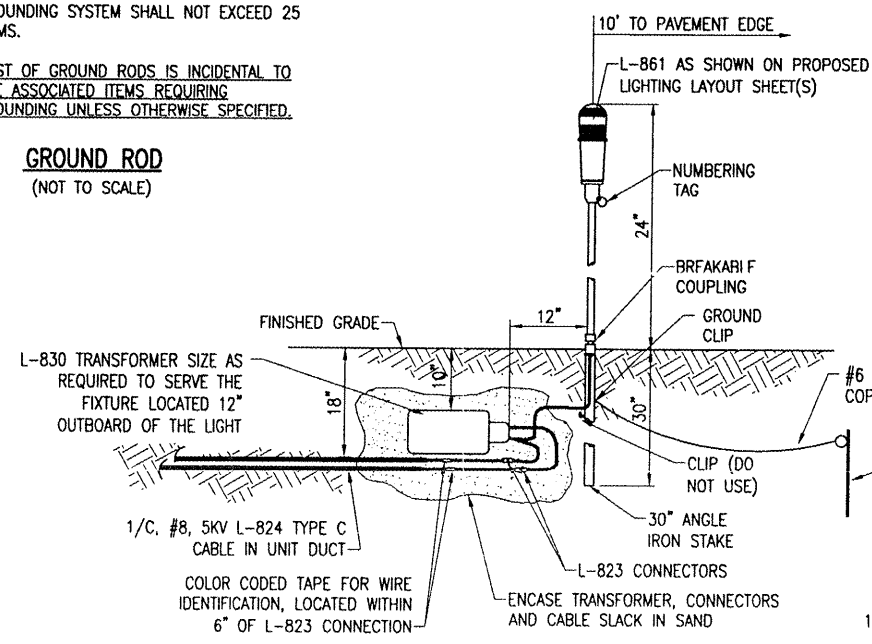

**MEDIUM INTENSITY LIGHT - STAKE MOUNTED**  
(NOT TO SCALE)

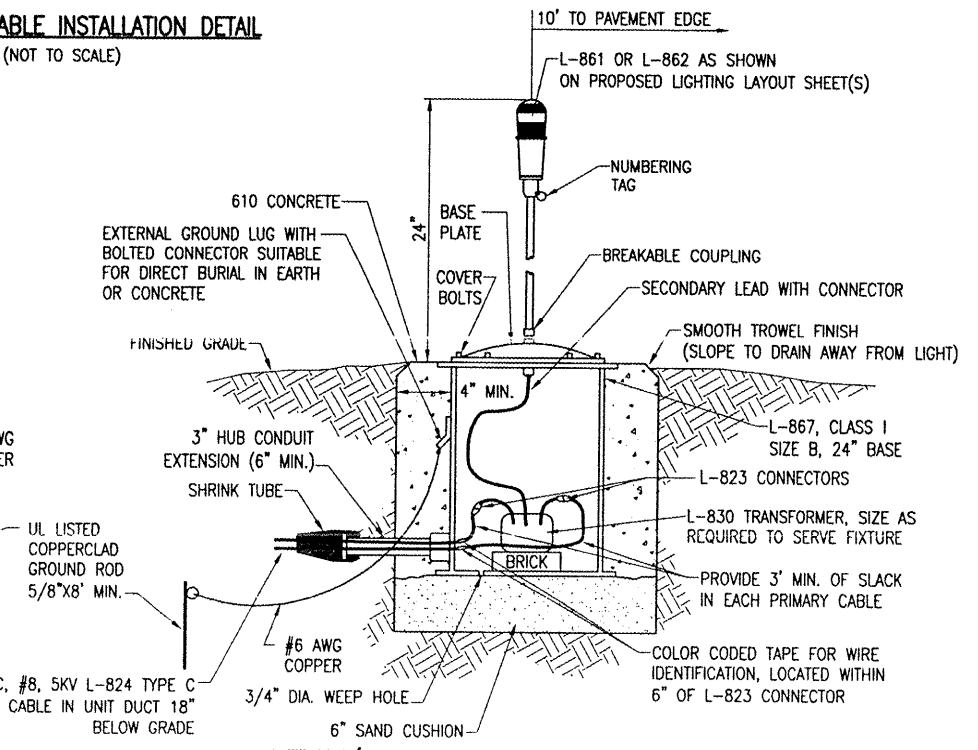

**MEDIUM/HIGH INTENSITY LIGHT - BASE MOUNTED**  
(NOT TO SCALE)

BY	
REVISION	
DATE	

FAIRFIELD MUNICIPAL AIRPORT  
 FAIRFIELD, ILLINOIS

10/10/08	CAH	REVIEWED
08/22/08	BAK	DRAWN
08/22/08	KNL	LAYOUT

**HANSON**  
 Hanson Professional Services Inc.  
 1626 South Sixth Street  
 Springfield, Illinois 62703-2686  
 Offices Nationwide

REPLACE RUNWAY & TAXIWAY LIGHTING  
 PROPOSED ELECTRICAL DETAILS  
 SHEET 2

FEB 08, 2009 1:45 PM HAGL000382  
 \\FAIRPORTS\FAIRFIELD\08A0073\AIRPORT\SHEETS\R-542ELE.CWG - ELEC DETAILS