

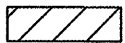



**PHASE 1 CONSTRUCTION**

- LEGEND**
-  PHASE 1 CONSTRUCTION (EQUIPMENT HEIGHT 25')
  -  CONTRACTOR'S ACCESS/HAUL ROAD
  -  TYPE 2 BARRICADES WITH STEADY BURN RED LIGHTS AND CONSTRUCTION FENCING
  -  AIRCRAFT MOVEMENT OPERATIONS
  -  AOA AIR OPERATIONS AREA (A.O.A.)
  -  CONSTRUCTION STAGING

WH008

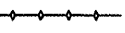

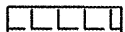
Whiteside County **AIRPORT**  
JOSEPH H. BITTORF FIELD

Whiteside County  
Airport

Sterling / Rock Falls,  
Illinois

Whiteside County  
Airport

AIP: 3-17-0098-B15  
SQI-3872  
REHABILITATE  
SOUTH TERMINAL  
APRON / NORTH  
T-HANGAR  
PAVEMENTS

**CONSTRUCTION PHASING STAGE 1 - NOTES:**

1. CONTRACTOR SHALL PROVIDE RESIDENT ENGINEER WITH APPROVED PROGRESS SCHEDULE SHOWING START/ STOP DATES OF ALL PHASES. APPROVED PROGRESS SCHEDULE SHALL BE SUBMITTED 3 WORKING DAYS PRIOR TO START OF CONSTRUCTION.
2. PHASE 1 CONSTRUCTION ACTIVITIES SHALL TAKE PLACE BETWEEN THE HOURS OF OPERATION SUBMITTED BY THE CONTRACTOR AND APPROVED BY THE AIRPORT MANAGER AND RESIDENT ENGINEER.
3. PHASE 1 CONSTRUCTION SHALL BE COMPLETED PRIOR TO THE START OF PHASE 2.
4. PHASE 1 WORK AREA DESCRIPTION. AN APPROVED PHASE 1 WORK AREA SCHEDULE SHALL BE SUBMITTED TO THE AIRPORT MANAGER AND RESIDENT ENGINEER 72 HOURS PRIOR TO THE START OF SAID CONSTRUCTION. DURING PHASE 1 WORK THE CONTRACTOR SHALL PLACE TYPE 2 BARRICADES WITH STEADY BURN RED LIGHTS IN THE LOCATION OF THE WORK BEING PERFORMED. ACCESS TO THE ADJACENT HANGARS SHALL BE MADE AVAILABLE AT ALL TIMES TO AIRCRAFT AND AIRPORT PERSONNEL. SHOULD AN AIRCRAFT OR AIRPORT PERSONNEL NEED ACCESS TO A HANGAR OR AN AREA THAT THE CONTRACTOR IS WORKING, THE CONTRACTOR SHALL MAKE SAID AREA ACCESSIBLE AND SHALL DO SO AT NO ADDITIONAL COST TO THE CONTRACT. THE CONTRACTOR SHALL KEEP THE IMMEDIATE AND SURROUNDING AREA FREE OF DUST AND DEBRIS AT ALL TIMES DURING CONSTRUCTION.

**PROJECT GENERAL NOTES (CONTD. FROM SHT. CPP1)  
(APPLY TO ALL STAGES):**

**15. UNATTENDED CONSTRUCTION ACCESS**  
THE OWNER WILL ASSESS THE CONTRACTOR A \$1,000.00 FINE FOR CLOSING AND/OR LOCKING EACH UNATTENDED ACCESS DOOR, GATE OR FENCE WHICH HAS BEEN IDENTIFIED AS A CONTRACTOR RESPONSIBILITY. AN ACCESS DOOR, GATE OR FENCE IS DEFINED AS "UNATTENDED" ANY TIME IT IS OPEN, UNLOCKED OR OTHERWISE RENDERED INEFFECTIVE IN PROVIDING SECURITY AND CONTRACTOR PERSONNEL ARE NOT PHYSICALLY IN A POSITION TO DETECT AND PREVENT UNAUTHORIZED ENTRY THROUGH IT. IN THE EVENT AIRPORT PERSONNEL ARE UNABLE TO SECURE AN UNATTENDED ACCESS DOOR, GATE OR FENCE, AIRPORT SECURITY PERSONNEL WILL BE POSTED AND CONTRACTORS WILL BE NOTIFIED. CONTRACTORS WILL BE CHARGED THE COST OF PROVIDING SECURITY PERSONNEL UNTIL THE AREA IS AGAIN SECURE.

**16. UNAUTHORIZED ACCESS TO AIRFIELD**  
THE CONTRACTOR SHALL RESTRICT ALL ACTIVITIES TO THE CONSTRUCTION AREA DETAILED IN THE PHASING PLAN. ANY UNAUTHORIZED MOVEMENTS, PEDESTRIAN OR VEHICULAR, BEYOND THE CONSTRUCTION LIMITS SHOWN SHALL BE CONSIDERED AN AIRFIELD INCURSION. AIRFIELD INCURSIONS, AT THE DISCRETION OF THE AIRPORT MANAGER, MAY BE FINED \$10,000.00 PER INCIDENT. INCURSION FINES WILL BE ASSESSED IMMEDIATELY AND TAKEN FROM MONIES DUE THE CONTRACTOR ON THE NEXT CONSTRUCTION PAYMENT.

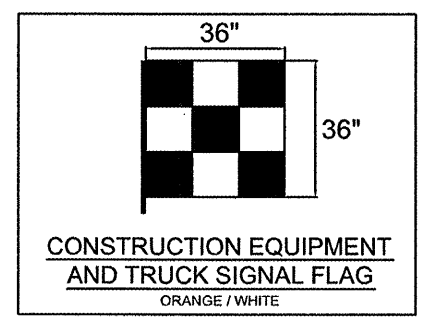

- ① Lat. 41 44 36.25; Long. 89 41 01.26; Grd. El. 648.0; Equip. Ht. 25'; **Top El. 673.0**
- ② Lat. 41 44 33.96; Long. 89 41 01.38; Grd. El. 648.0; Equip. Ht. 25'; **Top El. 673.0**

**CONSTR. PHASING STAGE 1**

Revisions		
No.	Date	Description

0 1  
THIS BAR IS EQUAL TO 1"  
AT FULL SCALE (17 X 11).

DESIGN BY:	CMT- RFD
DRAWN BY:	CMT- RFD
CHECKED BY:	CMT- RFD
APPROVED BY:	JGP
DATE:	11.21.08
JOB No:	08292-05-00

**CONSTRUCTION  
PHASING STAGE  
1  
(CPS1)**

07