

STATE OF ILLINOIS  
DEPARTMENT OF TRANSPORTATION

FAP RTE	SECTION	COUNTY	TOTAL SHEETS	SHEET NO.
693	(12B)BR, BDR, BJR	TAZEWELL	63	1
		ILLINOIS	CONTRACT NO. 68E79	

63 + 5 = 68 TOTAL SHEETS

D-94-015-19

INDEX OF SHEETS

1. COVER SHEET
2. GENERAL NOTES & PROJECT SPECIFIC NOTES
3. STATUS OF UTILITIES
- 4-8. SUMMARY OF QUANTITIES
9. EXISTING TYPICAL SECTIONS
- 10-11. SCHEDULE OF QUANTITIES
12. GENERAL PLAN
- 13-20. PROPOSED TRAFFIC CONTROL
- 21-22. GUARDRAIL DETAILS
- 23-45E. STRUCTURAL DETAILS
- 46-55. ELECTRICAL DETAILS
- 56-63. DISTRICT 4 STANDARDS

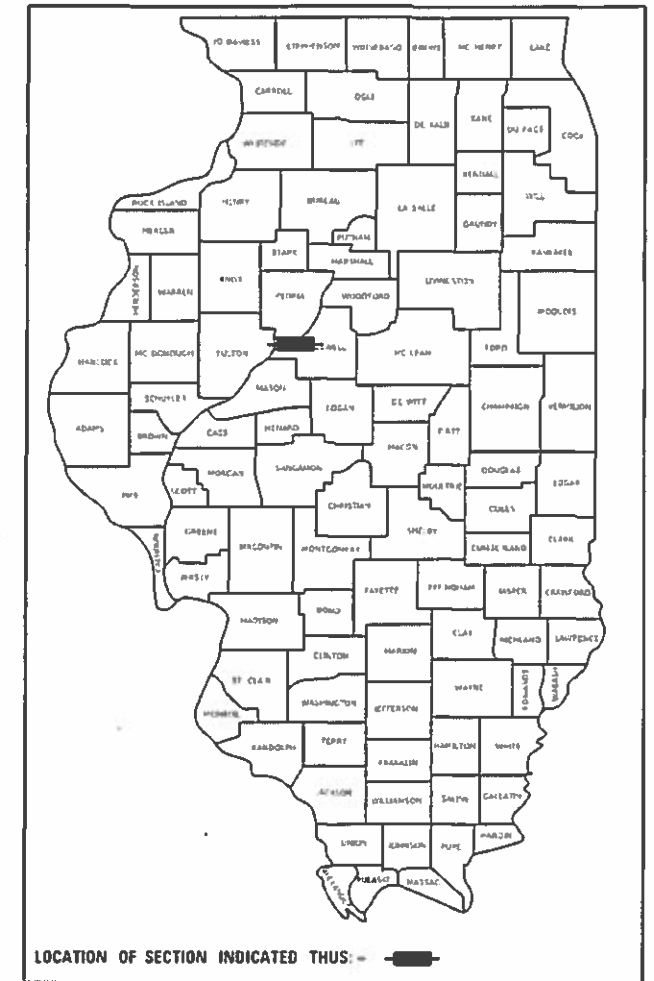
PROPOSED  
HIGHWAY PLANS

FAP ROUTE 693 (IL 9)  
SECTION (12B)BR, BDR, BJR  
NHPP-PQR8(399)  
BRIDGE PRESERVATION  
TAZEWELL COUNTY

C-94-021-19

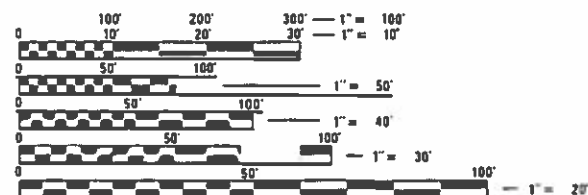
LIST OF ILLINOIS DOT HIGHWAY STANDARDS

- 001001-02
- 606001-07
- 630301-09
- 631033-08
- 643001-02
- 701101-05
- 701106-02
- 701423-10
- 701426-09
- 701428-01
- 701601-09
- 701901-08
- 704001-08
- 725001-01
- 780001-05
- 782006-01
- 821101-02
- 830011-03



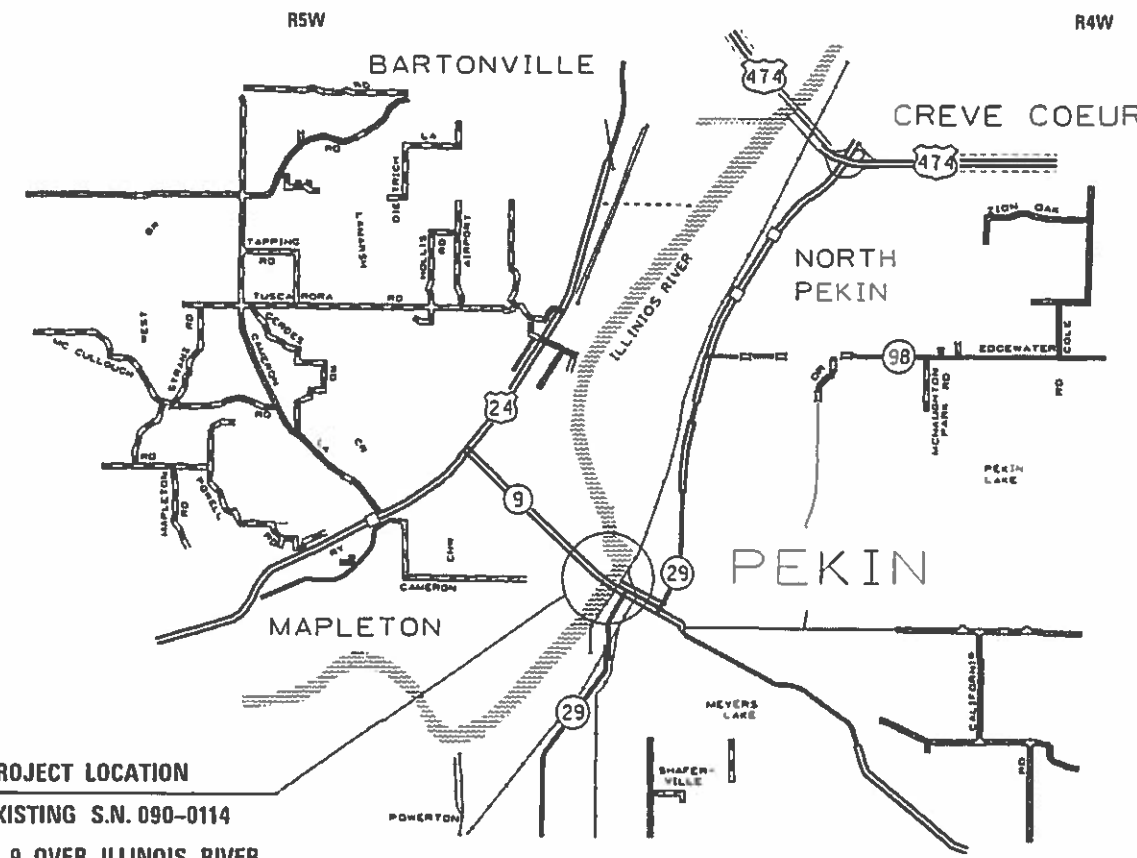
LOCATION OF SECTION INDICATED THUS: [shaded area symbol]

S.N. 090-0114 (MCNAUGHTON BRIDGE) OVER THE ILLINOIS RIVER:  
THE SCOPE OF THIS CONTRACT CONSISTS OF THE REPLACEMENT OF BEARINGS AND EXPANSION JOINTS, BRIDGE DECK PATCHING, SUBSTRUCTURE REPAIRS, AND MISCELLANEOUS BRIDGE LIGHTING REPAIRS.



FULL SIZE PLANS HAVE BEEN PREPARED USING STANDARD ENGINEERING SCALES. REDUCED SIZED PLANS WILL NOT CONFORM TO STANDARD SCALES. IN MAKING MEASUREMENTS ON REDUCED PLANS, THE ABOVE SCALES MAY BE USED.

J.U.L.I.E.  
JOINT UTILITY LOCATION INFORMATION FOR EXCAVATORS  
1-800-892-0123  
OR 811



PROJECT LOCATION  
EXISTING S.N. 090-0114  
IL 9 OVER ILLINOIS RIVER

GROSS LENGTH = 4752 FT. = 0.900 MILE  
NET LENGTH = 4752 FT. = 0.900 MILE

PROJECT ENGINEER: NICK JACK  
PROJECT MANAGER: JOSH JOCHUMS  
CONTRACT NO. 68E79  
CATALOG NO. 035699-00D

STATE OF ILLINOIS  
DEPARTMENT OF TRANSPORTATION

SUBMITTED Dec 12 2019  
Kenneth A. Barnett RSO  
REGIONAL ENGINEER

Jan 31 2020  
[Signature]  
ENGINEER OF DESIGN AND ENVIRONMENT

Jan 31 2020  
[Signature]  
DIRECTOR OF HIGHWAYS PROJECT IMPLEMENTATION

PRINTED BY THE AUTHORITY  
OF THE STATE OF ILLINOIS

GENERAL NOTES

AVAILABILITY OF ELECTRONIC FILES

MicroStation and GEOPAK files of this project will be made available to the Contractor after contract award. If there is a conflict between the electronic files and the printed contract plans and documents, the printed contract plans and documents shall take precedence over the electronic files. The Contractor shall accept all risk associated with using the electronic files and shall hold the Department harmless for any errors or omissions in the electronic files and the data contained therein. Errors or delays resulting from the use of the electronic files by the Contractor shall not result in an extension of time for any interim or final completion date or shall not be considered cause for additional compensation. The Contractor shall not use, share, or distribute these electronic files except for the purpose of constructing this contract. Any claims by third parties due to use or errors shall be the responsibility of the Contractor. The Contractor shall include this disclaimer with the transfer of these electronic files to any other parties and shall include appropriate language binding them to similar responsibilities.

PLAN ELEVATIONS - U.S.G.S. MEAN SEA LEVEL DATUM

Use one of the following two options.

1. All elevations shown on the plans are established from U.S.G.S. mean sea level datum.
2. All elevations shown refer to U.S.G.S. datum at mean sea level unless otherwise noted.

PROPERTY OWNER ACCESS REQUIREMENTS

Access must be maintained to all existing properties during construction per Article 107.09 unless arrangements are made in writing by the Contractor with the property owners with a copy to the Engineer for short-term closures.

CRITICAL PATH WORK SCHEDULE REQUIREMENT

The Contractor will submit to the Engineer a satisfactory progress schedule and critical path schedule which shall show the proposed sequence of work at the time of the pre-construction conference.

ENVIRONMENTAL REVIEWS

Prior to the use of any proposed borrow areas, use areas (temporary access roads, detours, run-arounds, etc.) and/or waste areas, the Contractor shall file the required environmental resource request surveys according to Section 107.22 of the Standard Specifications. These surveys are required in order for the Department to conduct cultural and biological resource surveys for the proposed site.

The required environmental resource documentation shall include the following:

- BDE Form 2289 (Cultural and Natural Resources Review of Borrow Areas)
- BDE Form 2290 (Waste/Use Area Review)
- A location map showing the size limits and location of the use area
- Color photographs depicting the use area
- Borrow Area Entry Agreement form - D4 PI0101

Prior to any waste materials being removed from the construction site the required environmental resource surveys shall be obtained and filed by the Contractor. Excess waste products removed from the construction site shall be disposed of as required in Section 202.03 of the Standard Specifications.

Any protruding metal bars shall be removed prior to the disposal of broken concrete at approved disposal sites.

Please note that a minimum of four weeks shall be allowed for the District to obtain the required environmental clearances and six weeks for the required borrow site environmental clearances.

ADDITIONAL SUPPLEMENTAL TRAFFIC CONTROL

The Department reserves the right at any time to add additional Traffic Control Systems or devices within the active contract limits, by means of an additional contract. All terms of Article 105.08 of the Standard Specifications shall be followed by each Contractor.

SIGNING

Sign locations may vary from the stations shown on the plans in accordance with directions from the Engineer at the time of construction. Sign locations may be adjusted in the field to avoid any found utilities.

All wood post locations shall be verified with the Bureau of Operations, Traffic Section, before installation.

NO PASSING ZONE VERIFICATION

The resident shall contact Operations to verify the location of no passing zones prior to placement of centerline striping.

PROJECT SPECIFIC NOTES

1. All work between Sta. 104+89 and 2nd St. on Ann Eliza St. shall be completed before any other work shall begin. This work shall utilize TRAFFIC CONTROL AND PROTECTION, STANDARD 701601. After the completion of this work, TRAFFIC CONTROL AND PROTECTION, STANDARD 701423 shall take priority.
2. PROTECTIVE SHIELD will be required at and adjacent to Piers 5, 6, and 9. The protective shield will be required for the full width of the bridge. The protective shield shall protect a total of 20 ft. of bridge length at each pier. The 20 ft. of bridge length shall be centered over each pier.

MODEL: sheets  
 FILE: \\nrcs\pub\pubroom\dat\links\gov\PI0101\Documents\DOT\_Offices\District\_4\Projects\IDA\_68E79\CAD\Drawings\Plan\_Seed\_File.dgn

USER NAME = jochumsjg	DESIGNED -	REVISED -
	DRAWN -	REVISED -
PLOT SCALE = 40.0000 ' / in.	CHECKED -	REVISED -
PLOT DATE = 12/13/2019	DATE -	REVISED -

**STATE OF ILLINOIS  
DEPARTMENT OF TRANSPORTATION**

**GENERAL NOTES AND  
PROJECT SPECIFIC NOTES**

SCALE: SHEET OF SHEETS STA. TO STA.

F.A.P. RTE.	SECTION	COUNTY	TOTAL SHEETS	SHEET NO.
693	(12B)BR:BDR,BJR	TAZEWELL	63	2
			CONTRACT NO. 68E79	
		ILLINOIS	FED. AID PROJECT	









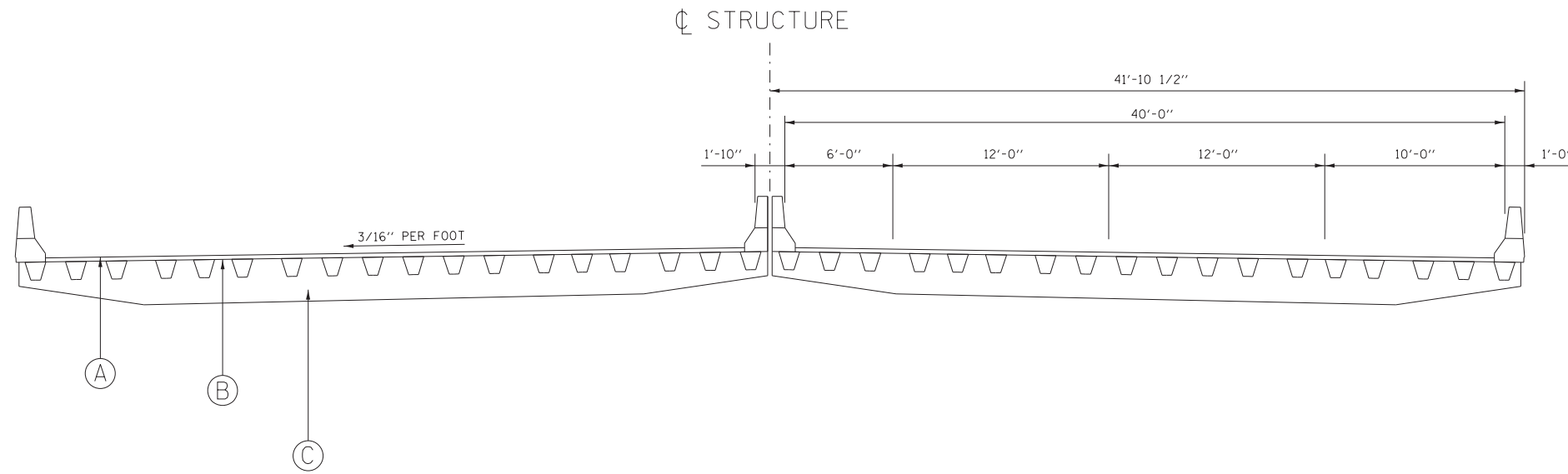




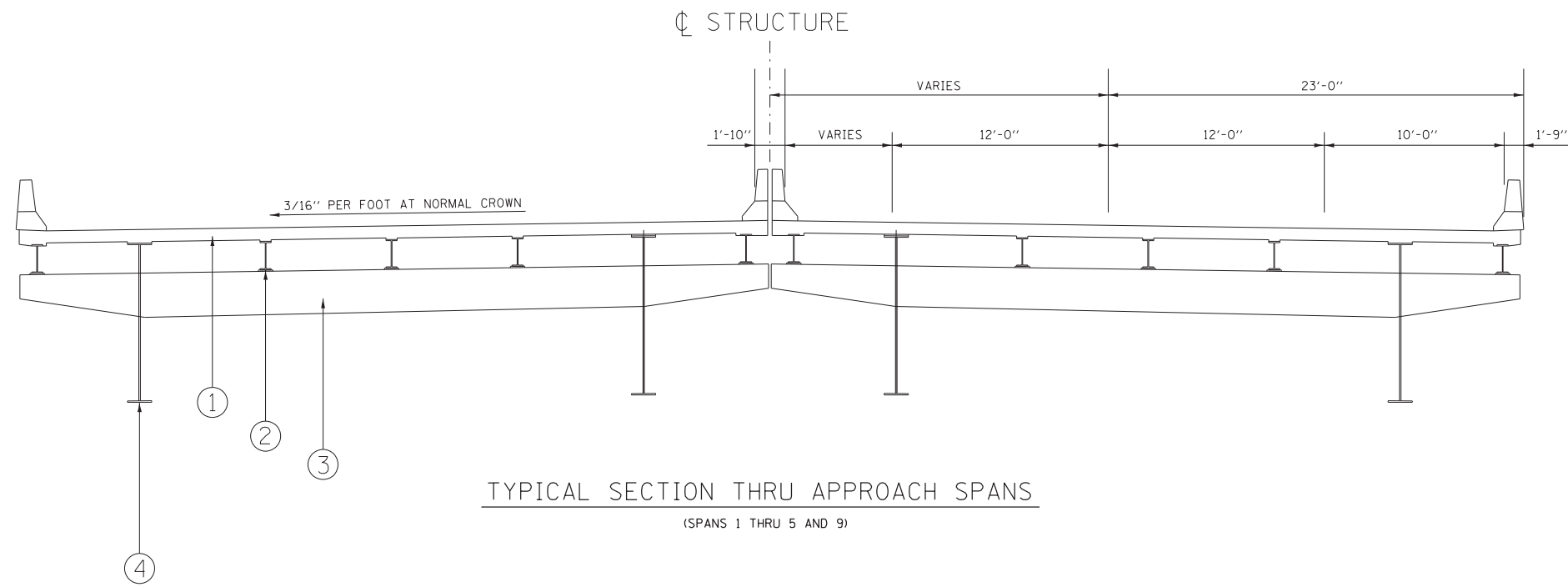


EXISTING

- Ⓐ 5" CONCRETE WEARING SURFACE
- Ⓑ ORTHOTROPIC STEEL PLATE DECK
- Ⓒ ③ FLOOR BEAMS AT 20' ON CENTERS
- ① 8" CONCRETE DECK
- ② WIDE FLANGE STRINGER
- ④ STEEL GIRDER



TYPICAL SECTION THRU MAIN RIVER SPANS  
(SPANS 6, 7, AND 8)



TYPICAL SECTION THRU APPROACH SPANS  
(SPANS 1 THRU 5 AND 9)

MODEL: sheets  
 FILE: Model: 6879\planroom\dat\illinois.gov\PWIDOT\Documents\DOT\_Offices\District\_4\Projects\ID4\_68E79\CAD\Draws\CAD\Drawings\Plan\_Seed Title.dgn

USER NAME = jochumsjg	DESIGNED -	REVISED -
	DRAWN -	REVISED -
PLOT SCALE = 40.0000 ' / in.	CHECKED -	REVISED -
PLOT DATE = 12/13/2019	DATE -	REVISED -

STATE OF ILLINOIS  
DEPARTMENT OF TRANSPORTATION

EXISTING TYPICAL SECTIONS

SCALE: SHEET OF SHEETS STA. TO STA.

F.A.P. RTE.	SECTION	COUNTY	TOTAL SHEETS	SHEET NO.
693	(12B)BR:BDR,BJR	TAZEWELL	63	9
CONTRACT NO. 68E79				
ILLINOIS FED. AID PROJECT				

PCC BASE COURSE WIDENING 10"	
LOCATIONS	35400500
	SY
STA. 105+58 TO 106+36 LT (ANN ELIZA ST.)	6.0
<b>TOTAL</b>	<b>6</b>

TRANSITIONAL COMBINATION CONCRETE CURB AND GUTTER	
LOCATION	60626500
	FOOT
STA. 105+42 TO 105+52 LT (ANN ELIZA ST.)	10
STA. 107+05 TO 107+15 LT (ANN ELIZA ST.)	10
STA. 105+25 TO 105+35 RT (ANN ELIZA ST.)	10
STA. 106+81 TO 106+91 RT (ANN ELIZA ST.)	10
<b>TOTAL</b>	<b>40</b>

TRAFFIC CONTROL SURVEILLANCE	
LOCATION	70103815
	CAL DAY
JOBSITE	10
<b>TOTAL</b>	<b>10</b>

COMBINATION CURB & GUTTER REMOVAL	
LOCATIONS	44000500
	FOOT
STA. 105+42 TO STA. 107+15 LT (ANN ELIZA ST.)	173.0
STA. 105+25 TO STA. 106+91 RT (ANN ELIZA ST.)	166.0
<b>TOTAL</b>	<b>339</b>

ENGINEER'S FIELD OFFICE, TYPE B	
LOCATION	67000500
	CAL MO
JOBSITE	6
<b>TOTAL</b>	<b>6</b>

CHANGEABLE MESSAGE SIGN	
LOCATION	70106800
	CAL MO
JOBSITE	0.5
<b>TOTAL</b>	<b>0.5</b>

TIE BARS 3/4"	
LOCATIONS	44213204
	EACH
STA. 105+42 TO STA. 107+15 LT (ANN ELIZA ST.)	59
STA. 105+25 TO STA. 106+91 RT (ANN ELIZA ST.)	57
<b>TOTAL</b>	<b>116</b>

PROTECTIVE SHIELD	
LOCATIONS	50157300
	SY
PIER 5	186.7
PIER 6	186.7
PIER 9	186.7
<b>TOTAL</b>	<b>560</b>

SHORT-TERM PAVEMENT MARKING						
LOCATION			NOTES	70300100	70300150	
STA	TO	STA		SHORT-TERM PAVEMENT MARKING	SHORT-TERM PAVEMENT MARKING REMOVAL	
				FT	SF	
<b>STAGE 1-EBL</b>						
62+90	TO	75+16	ONE LINE	1226	409	
75+16	TO	104+89	TWO LINES	5946	1982	
104+89	TO	105+69	ONE LINE	80	27	
<b>STAGE 1-WBL</b>						
75+74	TO	78+55	ONE LINE	281	94	
78+55	TO	106+62	TWO LINES	5614	1871	
106+62	TO	108+59	ONE LINE	197	66	
<b>STAGE 2-EBL</b>						
62+90	TO	75+25	ONE LINE	1235	412	
75+25	TO	104+98	TWO LINES	5946	1982	
104+98	TO	105+65	ONE LINE	67	22	
<b>STAGE 2-WBL</b>						
75+25	TO	105+76	TWO LINES	6102	2034	
105+76	TO	111+17	ONE LINE	541	180	
<b>TOTALS</b>				<b>27235</b>	<b>9078</b>	

TRAFFIC CONTROL AND PROTECTION, STANDARD 701423	
LOCATION	70100325
	EACH
STA 62+90 TO 111+17 (STAGE CONSTRUCTION)	1
<b>TOTAL</b>	<b>1</b>

MOBILIZATION	
LOCATION	67100100
	L SUM
JOBSITE	1
<b>TOTAL</b>	<b>1</b>

TRAFFIC CONTROL AND PROTECTION, STANDARD 701601	
LOCATION	70102630
	L SUM
STA. 104+89 TO STA. 107+15 (EAST APPROACH IN THE WEST BOUND LANES)	1
<b>TOTAL</b>	<b>1</b>

COMBINATION CONCRETE CURB AND GUTTER, TY M (SPECIAL)	
LOCATION	X6061815
	FOOT
STA. 105+52 TO STA. 107+05 LT (ANN ELIZA ST.)	153
STA. 105+35 TO STA. 106+81 RT (ANN ELIZA ST.)	146
<b>TOTAL</b>	<b>299</b>

MODEL: sheets  
 FILE: h:\mfc\_2019\pub\harron\mfc\_2019\pub\harron\DOT Documents\DOT Office\Drawings\Plan\_Seed File.dgn

USER NAME = jochumsjg	DESIGNED -	REVISED -
	DRAWN -	REVISED -
PLOT SCALE = 40.0000 ' / in.	CHECKED -	REVISED -
PLOT DATE = 12/13/2019	DATE -	REVISED -

**STATE OF ILLINOIS**  
**DEPARTMENT OF TRANSPORTATION**

SCHEDULE OF QUANTITIES			
SCALE:	SHEET	OF SHEETS	STA. TO STA.

F.A.P. RTE.	SECTION	COUNTY	TOTAL SHEETS	SHEET NO.
693	(12B)BR;BDR,BJR	TAZEWELL	63	10
				CONTRACT NO. 68E79
		ILLINOIS	FED. AID PROJECT	



GUARDRAIL SCHEDULE					
LOCATION	63100089	63100167	63200310	7820005	72501000
	TRAFFIC BARRIER TERMINAL, TYPE 6B	TRAFFIC BARRIER TERMINAL, TYPE 1 (SPECIAL) TANGENT	GUARDRAIL REMOVAL	GUARDRAIL REFLECTORS, TYPE A	TERMINAL MARKER- DIRECT APPLIED
	EACH	EACH	FOOT	EACH	EACH
STA. 78+30 RT (MAINLINE)	1			1	
STA. 105+13 LT (ANN ELIZA ST.)	1			1	
STA. 105+00 RT (ANN ELIZA ST.)	1			1	
STA. 77+43 RT (MAINLINE)		1		1	1
STA. 106+04 RT (ANN ELIZA ST.)		1		1	1
STA. 105+83 LT (ANN ELIZA ST.)		1		1	1
STA. 74+54 TO STA. 78+30 RT (MAINLINE)			376		
STA. 105+00 TO STA. 105+69 RT (ANN ELIZA ST.)			69		
STA. 105+13 TO STA. 105+94 LT (ANN ELIZA ST.)			81		
<b>TOTAL</b>	<b>3</b>	<b>3</b>	<b>526</b>	<b>6</b>	<b>3</b>

PAVEMENT MARKINGS					
LOCATION			X0327980	78009004	
STA	TO	STA	PAVEMENT MARKING REMOVAL - WATER BLASTING	MODIFIED URETHANE PAVEMENT MARKING - LINE 4"	
			SF	FOOT	
63+90	TO	109+00			
2 WHITE			3007	9020	
2 YELLOW			3007	9020	
2 SKIP DASH			752	2255	
<b>TOTALS</b>			<b>6765</b>	<b>20295</b>	

TEMPORARY PAVEMENT MARKINGS					
LOCATION			70300220	X7030005	
STA	TO	STA	TEMPORARY PAVEMENT MARKING - 4"	TEMPORARY PAVEMENT MARKING REMOVAL	
			FOOT	SF	
63+90	TO	109+00			
2 WHITE			9020	3007	
2 YELLOW			9020	3007	
2 SKIP DASH			2255	752	
<b>TOTALS</b>			<b>20295</b>	<b>6765</b>	

TRAFFIC CONTROL ITEMS				
LOCATION	70400100	70400200	70600250	70600350
	TEMPORARY CONCRETE BARRIER	RELOCATE TEMPORARY CONCRETE BARRIER	IMPACT ATTENUATORS, TEMPORARY (NON- REDIRECTIVE) TEST LEVEL 3	IMPACT ATTENUATORS, RELOCATE (NON- REDIRECTIVE) TEST LEVEL 3
	FOOT	FOOT	EACH	EACH
STAGE 1, EBL - STA. 76+67 TO STA. 104+89		2822		
STAGE 1, WBL - STA. 78+55 TO STA. 106+17		2762		
STAGE 2, EBL - STA. 76+66 TO STA. 104+89	2823			
STAGE 2, WBL - STA. 78+55 TO STA. 106+58	2803			
STA. 76+67 RT			1	
STA. 106+17 LT			1	
STA. 76+67 RT				1
STA. 106+58 LT				1
<b>TOTAL</b>	<b>5626</b>	<b>5584</b>	<b>2</b>	<b>2</b>

GUARDRAIL AGGREGATE EROSION CONTROL	
LOCATION	Z0001002 TON
STA. 77+10 TO STA. 78+30 RT (MAINLINE)	17.9
STA. 105+13 TO STA. 106+36 LT (ANN ELIZA ST.)	18.3
STA. 105+00 TO STA. 106+26 RT (ANN ELIZA ST.)	18.8
<b>TOTAL</b>	<b>55</b>

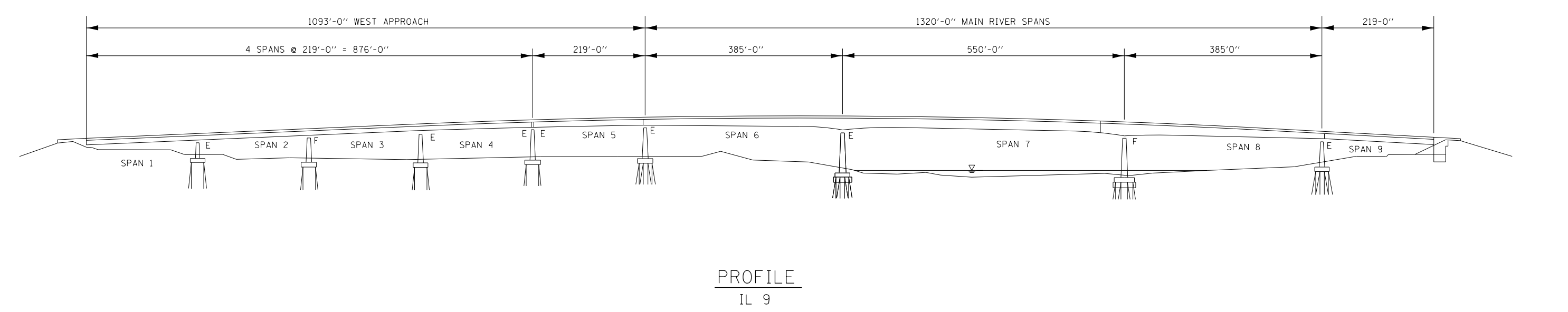
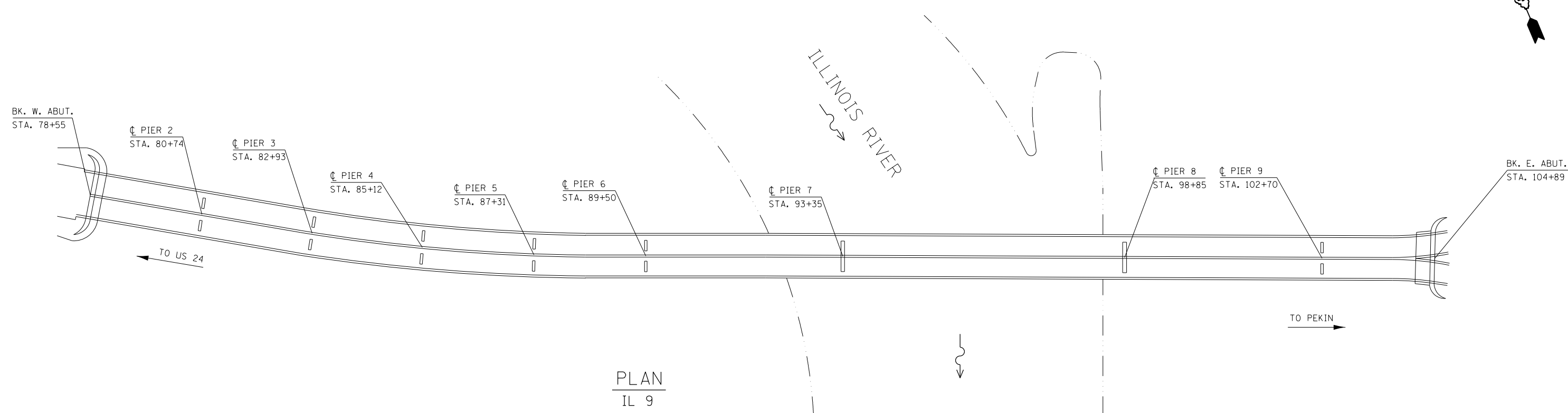
MODEL: sheets  
 FILE: h:\mfc\pub\pubroom.dwg  
 PROJECT: ILLINOIS STATE ROADWAY IMPROVEMENT PROJECT  
 SHEET: 68E79  
 DATE: 12/13/2019

USER NAME = jochumsjg	DESIGNED -	REVISED -
	DRAWN -	REVISED -
PLOT SCALE = 40,0000 ' / in.	CHECKED -	REVISED -
PLOT DATE = 12/13/2019	DATE -	REVISED -

**STATE OF ILLINOIS  
 DEPARTMENT OF TRANSPORTATION**

SCHEDULE OF QUANTITIES			
SCALE:	SHEET	OF	SHEETS

F.A.P. RTE.	SECTION	COUNTY	TOTAL SHEETS	SHEET NO.
693	(12B)BR:BDR,BJR	TAZEWELL	63	11
CONTRACT NO. 68E79				
ILLINOIS FED. AID PROJECT				



MODEL: sheets  
 FILE: h:\mfc\_2019\suppl\room\dat\illinois\gov\PWIDOT\Documents\DOT\_Offices\Director\_4\Projects\IL9\CAD\Drawings\Plan\_Seed\_1116.dgn

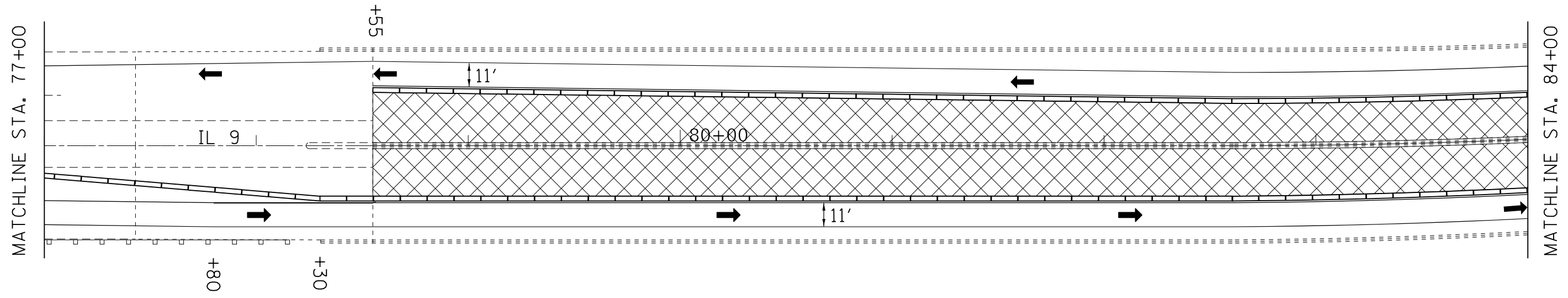
USER NAME = jochumsjg	DESIGNED -	REVISED -
	DRAWN -	REVISED -
PLOT SCALE = 40.0000 ' / in.	CHECKED -	REVISED -
PLOT DATE = 12/13/2019	DATE -	REVISED -

**STATE OF ILLINOIS**  
**DEPARTMENT OF TRANSPORTATION**




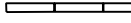

<b>GENERAL PLAN</b>			
SCALE:	SHEET	OF	SHEETS
	STA.	TO	STA.

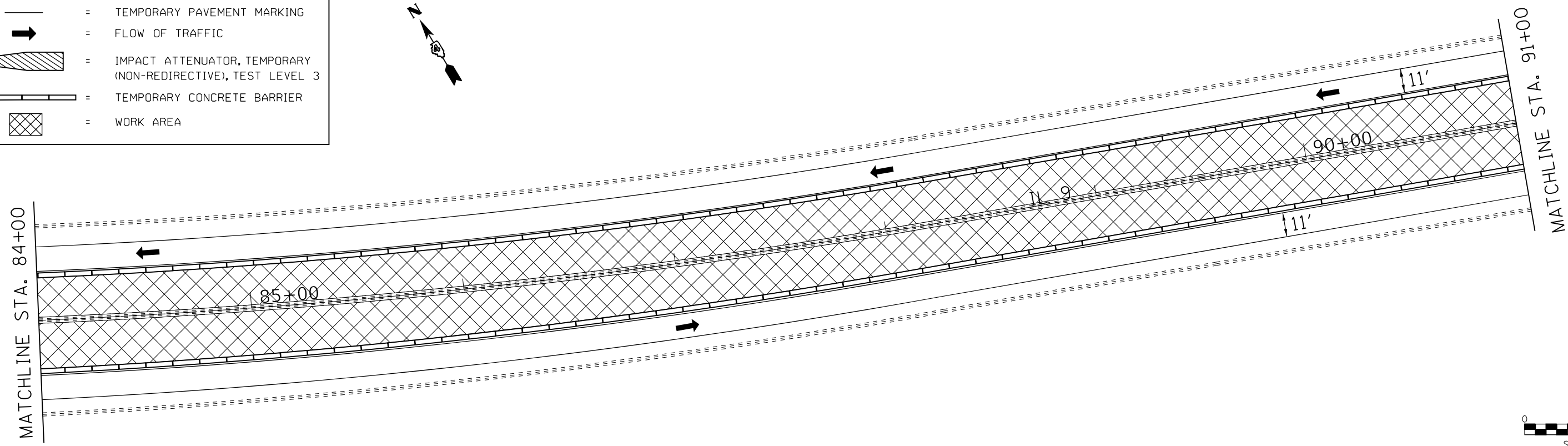
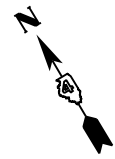
F.A.P. RTE.	SECTION	COUNTY	TOTAL SHEETS	SHEET NO.
693	(12B)BR:BDR,BJR	TAZEWELL	63	12
CONTRACT NO. 68E79			ILLINOIS FED. AID PROJECT	





**LEGEND**

-  = TEMPORARY PAVEMENT MARKING
-  = FLOW OF TRAFFIC
-  = IMPACT ATTENUATOR, TEMPORARY (NON-REDIRECTIVE), TEST LEVEL 3
-  = TEMPORARY CONCRETE BARRIER
-  = WORK AREA



MODEL: sheets  
 FILE: Model: 68E79\planroom.dwg  
 PROJECT: 68E79\planroom.dwg  
 OFFICE: IDOT  
 DATE: 12/13/2019

USER NAME = jochumsjg	DESIGNED -	REVISED -
PLOT SCALE = 50,0000 ' / in.	DRAWN -	REVISED -
PLOT DATE = 12/13/2019	CHECKED -	REVISED -
	DATE -	REVISED -

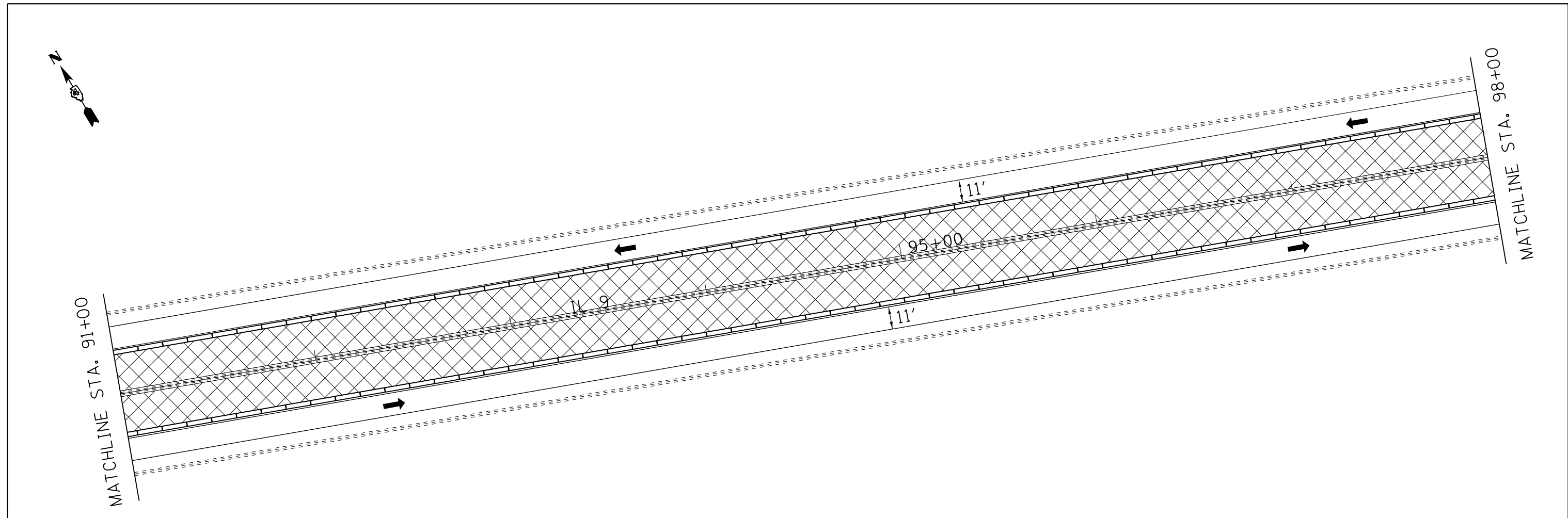
**STATE OF ILLINOIS  
DEPARTMENT OF TRANSPORTATION**

**PROPOSED TRAFFIC CONTROL  
STAGE 1**

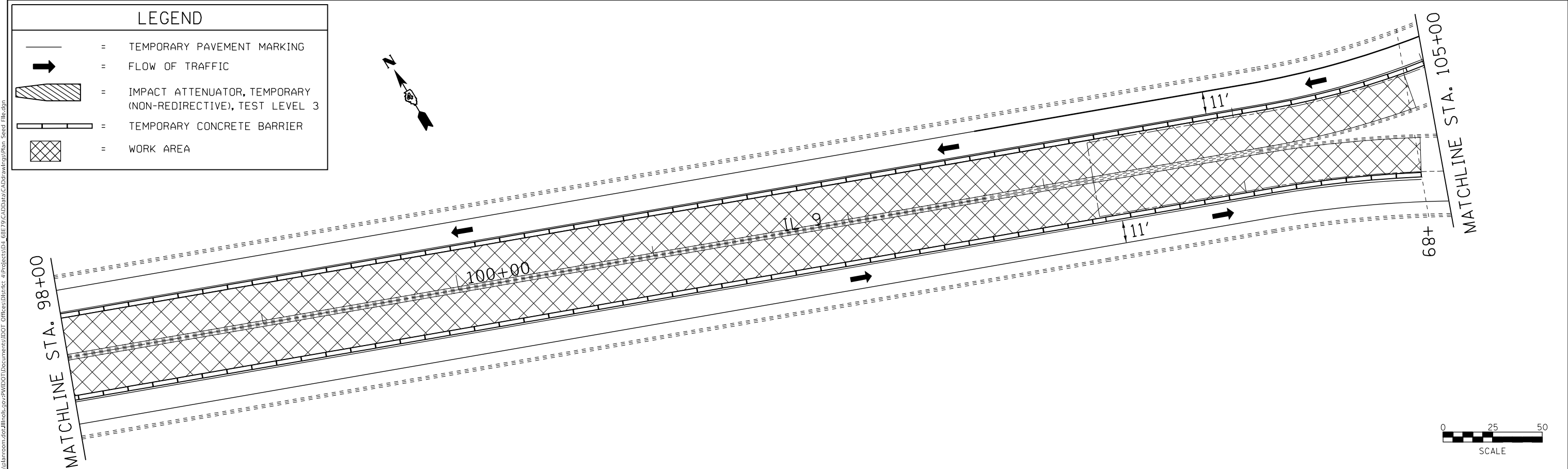
SCALE: SHEET OF SHEETS STA. TO STA.

F.A.P. RTE.	SECTION	COUNTY	TOTAL SHEETS	SHEET NO.
693	(128)BR,BDR,BJR	TAZEWELL	63	14
CONTRACT NO. 68E79				
ILLINOIS FED. AID PROJECT				

MODEL: h:\projects\68E79\CADD\Drawings\DOT\Office\Drawings\68E79\CADD\Drawings\Plan\_Seed\_Plan.dgn  
 FILE NAME: p:\pub\baronm.dta\illinois.gov\PHOTO\Documents\DOT\Office\Drawings\68E79\CADD\Drawings\Plan\_Seed\_Plan.dgn



LEGEND	
	= TEMPORARY PAVEMENT MARKING
	= FLOW OF TRAFFIC
	= IMPACT ATTENUATOR, TEMPORARY (NON-REDIRECTIVE), TEST LEVEL 3
	= TEMPORARY CONCRETE BARRIER
	= WORK AREA




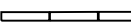
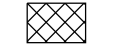


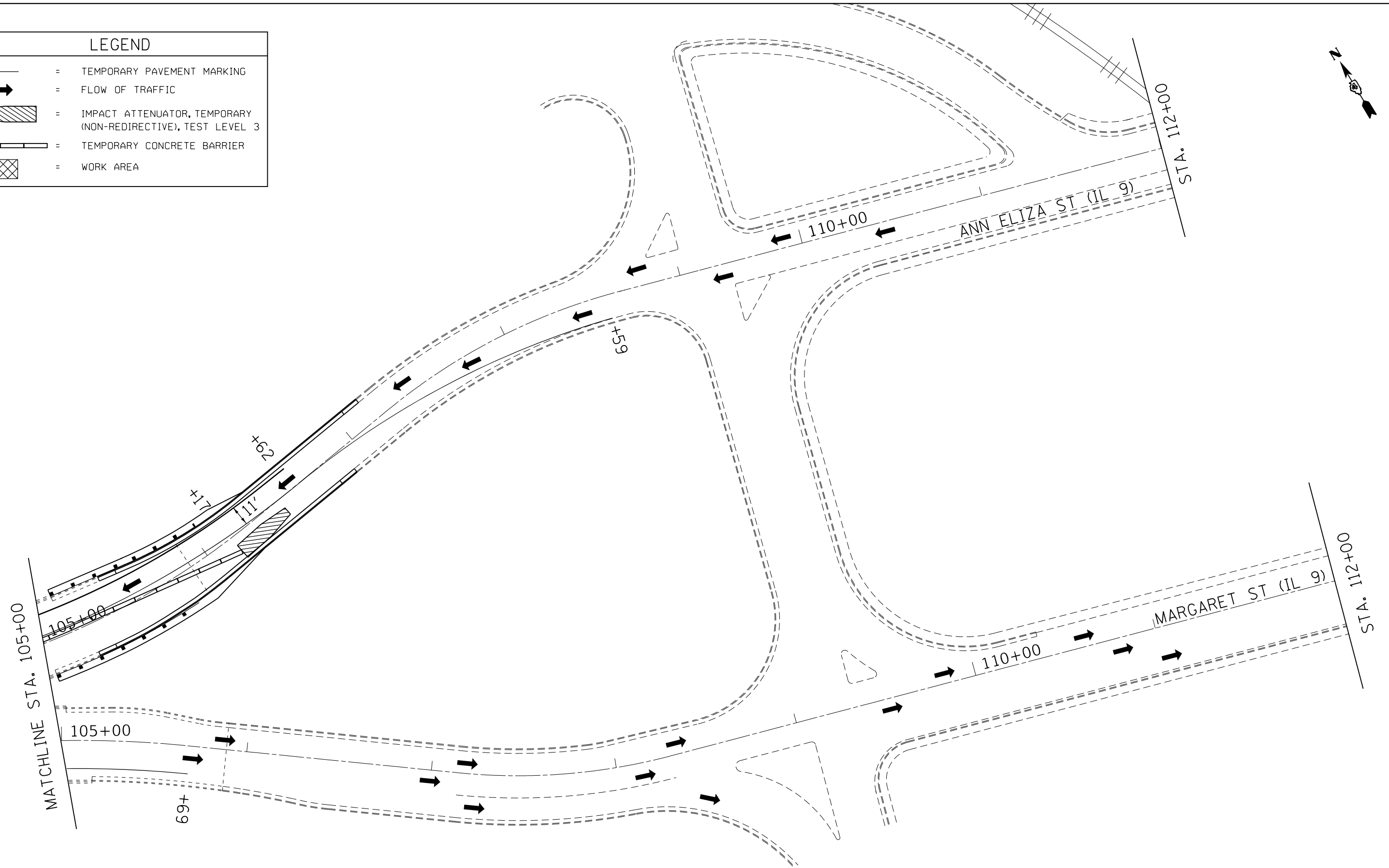
USER NAME = jochumsjg	DESIGNED -	REVISED -
PLOT SCALE = 50.0000' / in.	DRAWN -	REVISED -
PLOT DATE = 12/13/2019	CHECKED -	REVISED -
	DATE -	REVISED -

**STATE OF ILLINOIS**  
**DEPARTMENT OF TRANSPORTATION**

PROPOSED TRAFFIC CONTROL STAGE 1				
SCALE:	SHEET	OF	SHEETS	STA. TO STA.

F.A.P. RTE.	SECTION	COUNTY	TOTAL SHEETS	SHEET NO.
693	(12B)BR,BDR,BJR	TAZEWELL	63	15
CONTRACT NO. 68E79				
ILLINOIS		FED. AID PROJECT		

LEGEND	
	= TEMPORARY PAVEMENT MARKING
	= FLOW OF TRAFFIC
	= IMPACT ATTENUATOR, TEMPORARY (NON-REDIRECTIVE), TEST LEVEL 3
	= TEMPORARY CONCRETE BARRIER
	= WORK AREA



MODEL: sheets  
 FILE: h:\mfc\_p\pub\planroom.dwg  
 I:\projects\68E79\CADD\Drawings\Plan\_Seed\_Tile.dgn

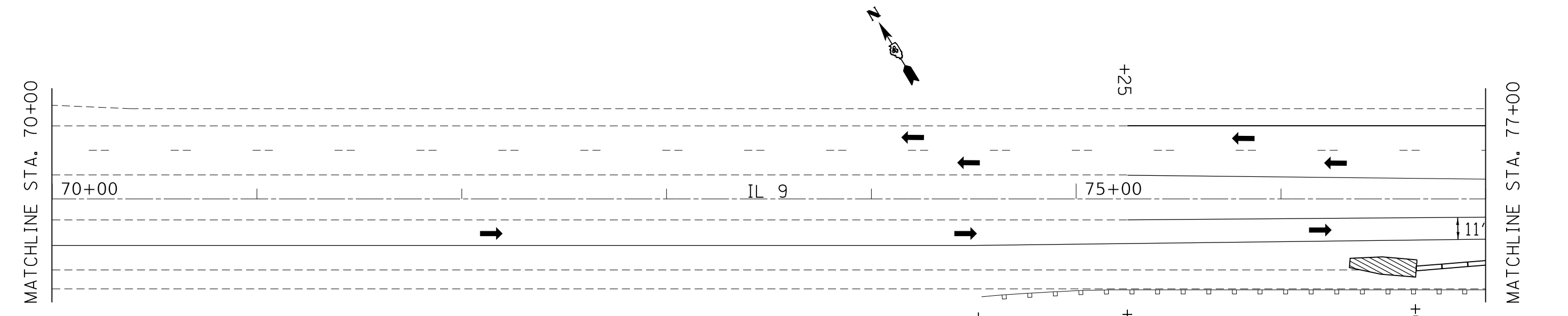
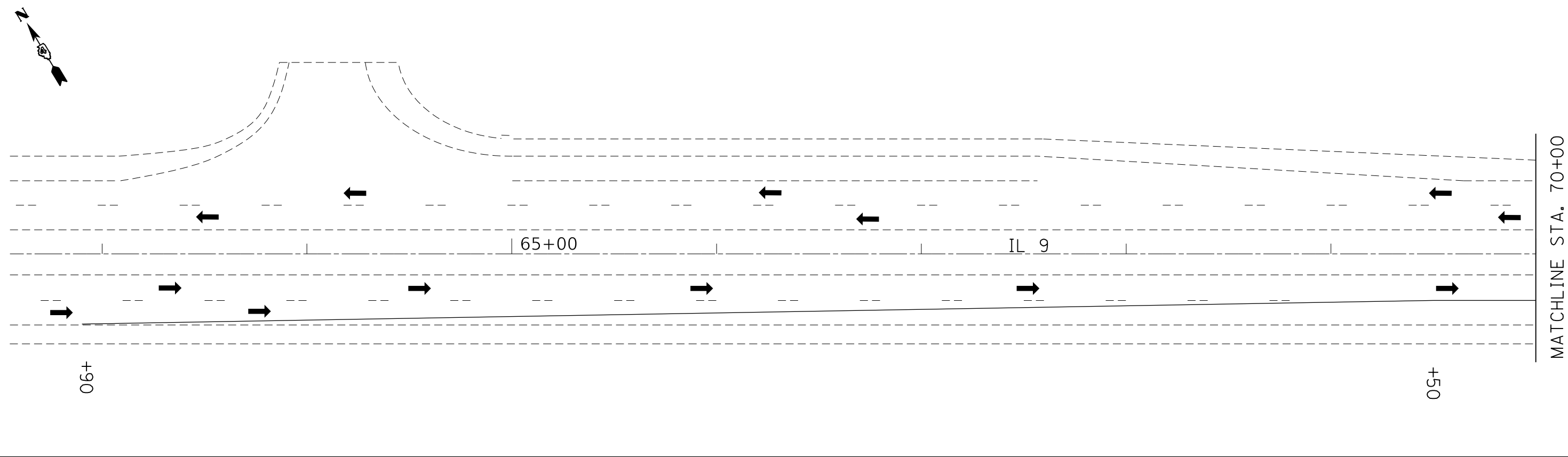
USER NAME = jochumsjg	DESIGNED -	REVISED -
PLOT SCALE = 50.0000 ' / in.	DRAWN -	REVISED -
PLOT DATE = 12/13/2019	CHECKED -	REVISED -
	DATE -	REVISED -






**STATE OF ILLINOIS**  
**DEPARTMENT OF TRANSPORTATION**

PROPOSED TRAFFIC CONTROL				
STAGE 1				
SCALE:	SHEET	OF	SHEETS	STA. TO STA.

F.A.P. RTE.	SECTION	COUNTY	TOTAL SHEETS	SHEET NO.
693	(128)BR,BDR,BJR	TAZEWELL	63	16
CONTRACT NO. 68E79				
ILLINOIS FED. AID PROJECT				

MODEL: h:\projects\687E79\CADD\Drawings\Plan\_Seed\_Plan.dgn  
 FILE NAME: P:\pub\baronm.dta\illinois.gov\PIWDOT\Documents\DOT\_Offices\Director\_4\Projects\687E79\CADD\Drawings\Plan\_Seed\_Plan.dgn



LEGEND	
	= TEMPORARY PAVEMENT MARKING
	= FLOW OF TRAFFIC
	= IMPACT ATTENUATOR, TEMPORARY (NON-REDIRECTIVE), TEST LEVEL 3
	= TEMPORARY CONCRETE BARRIER
	= WORK AREA

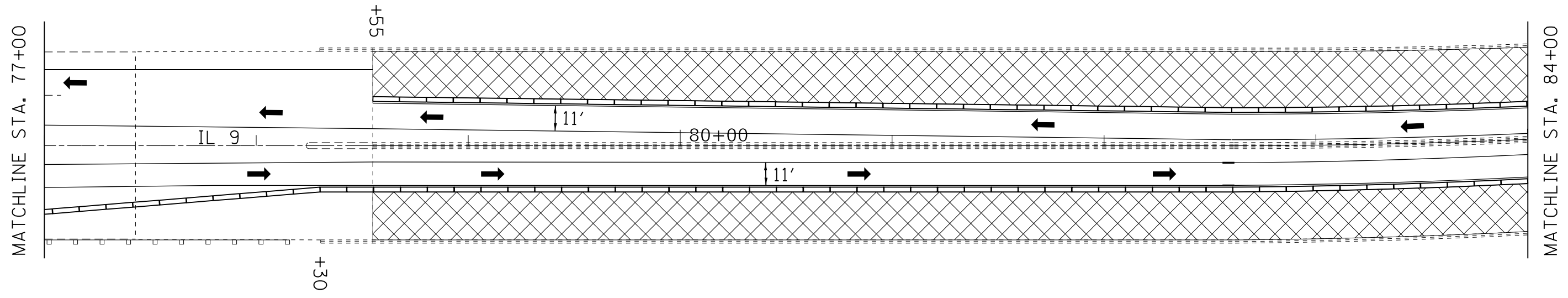
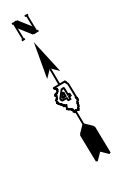


USER NAME = jochumsjg	DESIGNED -	REVISED -
PLOT SCALE = 50.0000' / in.	DRAWN -	REVISED -
PLOT DATE = 12/13/2019	CHECKED -	REVISED -
	DATE -	REVISED -




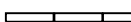

**STATE OF ILLINOIS**  
**DEPARTMENT OF TRANSPORTATION**

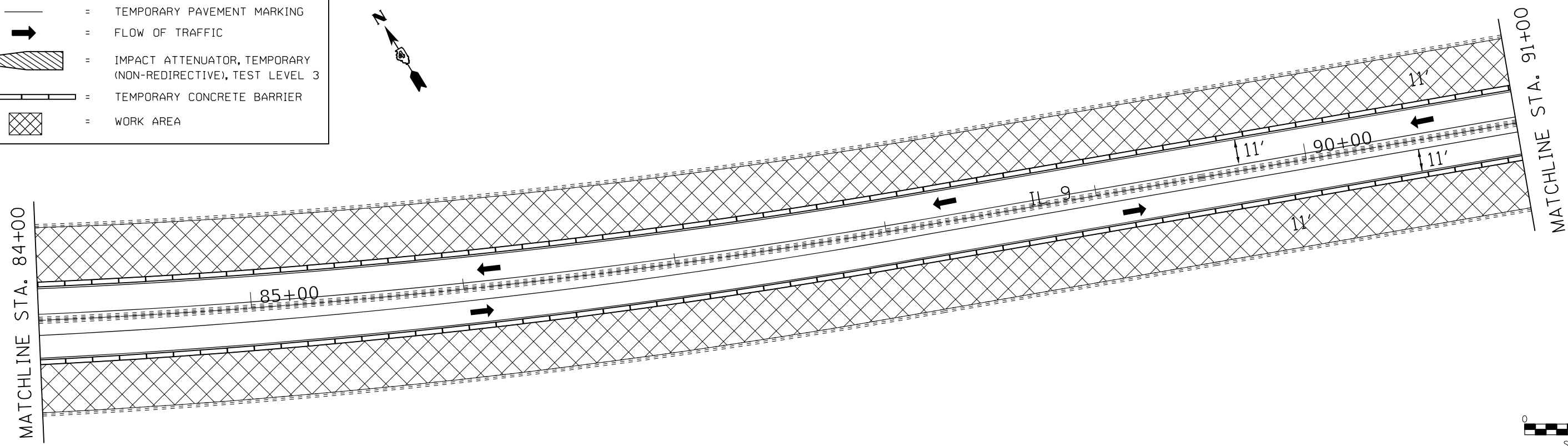
<b>PROPOSED TRAFFIC CONTROL STAGE 2</b>				
SCALE:	SHEET	OF	SHEETS	STA. TO STA.

F.A.P. RTE.	SECTION	COUNTY	TOTAL SHEETS	SHEET NO.
693	(128)BR,BDR,BJR	TAZEWELL	63	17
ILLINOIS FED. AID PROJECT			CONTRACT NO. 68E79	



**LEGEND**

-  = TEMPORARY PAVEMENT MARKING
-  = FLOW OF TRAFFIC
-  = IMPACT ATTENUATOR, TEMPORARY (NON-REDIRECTIVE), TEST LEVEL 3
-  = TEMPORARY CONCRETE BARRIER
-  = WORK AREA



MODEL: sheets  
 FILE NAME: P:\pub\baronm.dta\illinois.gov\PWIDOT\Documents\DOT\_Offices\District\_4\Projects\IDA\_68E79\CADD\Drawings\Plan\_Seed\_File.dgn

USER NAME = jochumsjg	DESIGNED -	REVISED -
	DRAWN -	REVISED -
PLOT SCALE = 50.0000' / in.	CHECKED -	REVISED -
PLOT DATE = 12/13/2019	DATE -	REVISED -

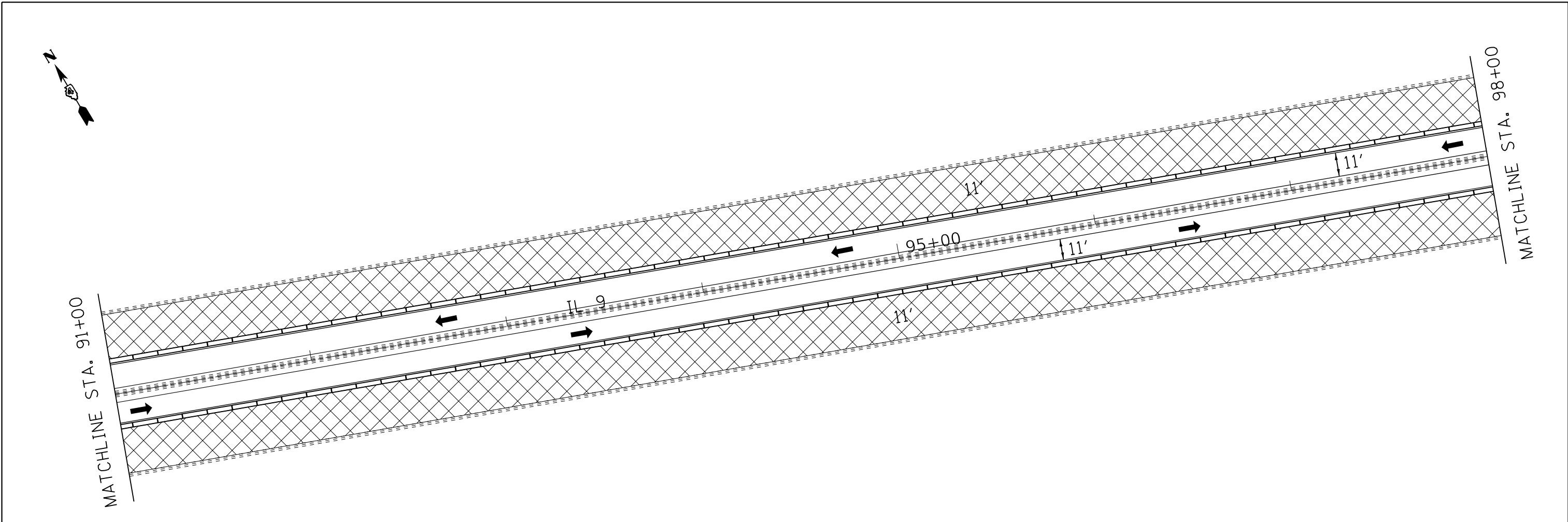
**STATE OF ILLINOIS  
DEPARTMENT OF TRANSPORTATION**

**PROPOSED TRAFFIC CONTROL  
STAGE 2**

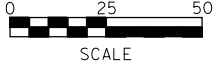
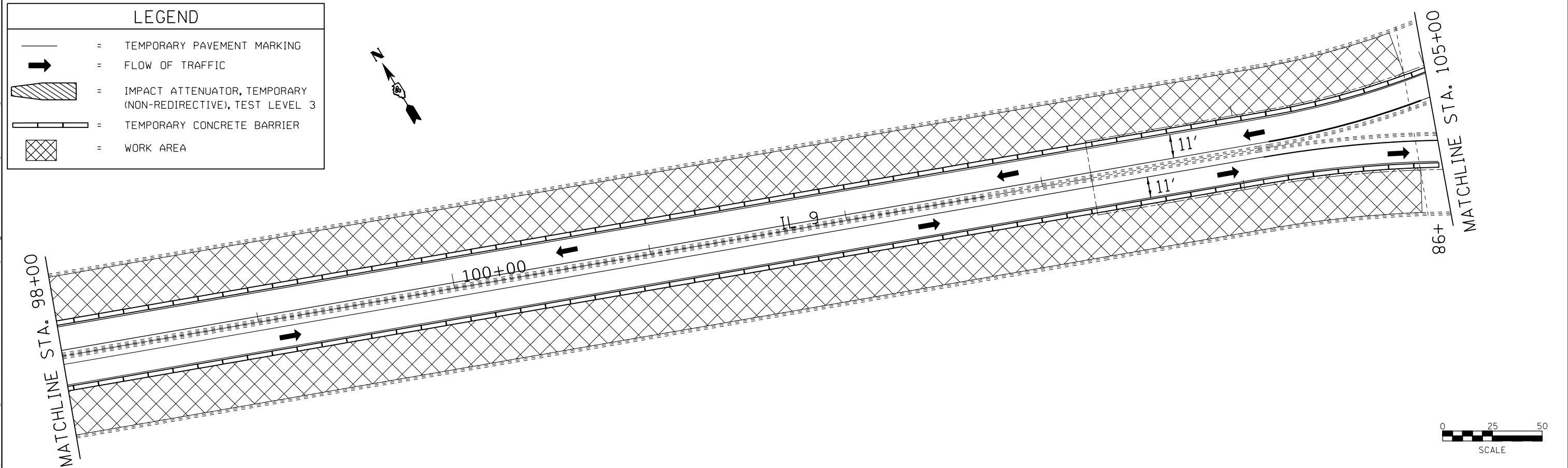
SCALE: SHEET OF SHEETS STA. TO STA.

F.A.P. RTE.	SECTION	COUNTY	TOTAL SHEETS	SHEET NO.
693	(12B)BR,BDR,BJR	TAZEWELL	63	18
CONTRACT NO. 68E79				
ILLINOIS FED. AID PROJECT				





LEGEND	
	= TEMPORARY PAVEMENT MARKING
	= FLOW OF TRAFFIC
	= IMPACT ATTENUATOR, TEMPORARY (NON-REDIRECTIVE), TEST LEVEL 3
	= TEMPORARY CONCRETE BARRIER
	= WORK AREA



MODEL: sheets  
 FILE: \home\p\pub\barroom\dot\illinois.gov\PIW\DOT\Documents\DOT\_Offices\District\_4\Projects\ID4\_68E79\CADD\Drawings\Plan\_Seed\_Tile.dgn

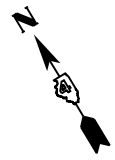
USER NAME = jochumsjg	DESIGNED -	REVISED -
PLOT SCALE = 50.0000' / in.	DRAWN -	REVISED -
PLOT DATE = 12/13/2019	CHECKED -	REVISED -
	DATE -	REVISED -

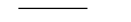


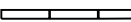
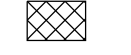
**STATE OF ILLINOIS**  
**DEPARTMENT OF TRANSPORTATION**

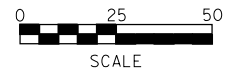
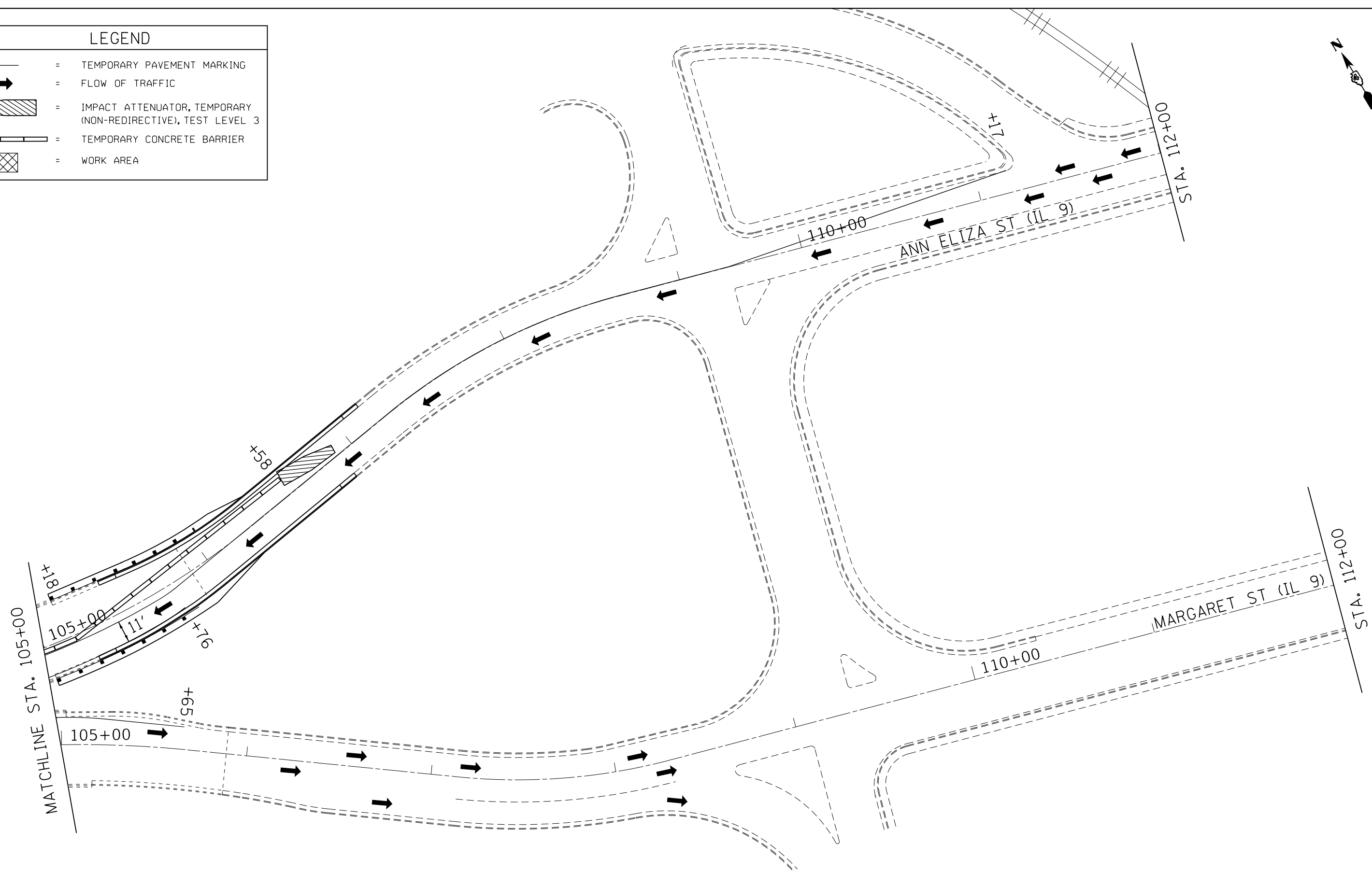
**PROPOSED TRAFFIC CONTROL**  
**STAGE 2**

SCALE: SHEET OF SHEETS STA. TO STA.

F.A.P. RTE.	SECTION	COUNTY	TOTAL SHEETS	SHEET NO.
693	(12B)BR,BDR,BJR	TAZEWELL	63	19
CONTRACT NO. 68E79				
ILLINOIS		FED. AID PROJECT		



LEGEND	
	= TEMPORARY PAVEMENT MARKING
	= FLOW OF TRAFFIC
	= IMPACT ATTENUATOR, TEMPORARY (NON-REDIRECTIVE), TEST LEVEL 3
	= TEMPORARY CONCRETE BARRIER
	= WORK AREA



MODEL: sheets  
 FILE: h:\mhc\p\suplanroom.d\illinois.gov\PWIDOT\Documents\DOT\_Offices\District\_4\Projects\IDA\_68E79\CADD\Drawings\Plan\_Seed\_File.dgn

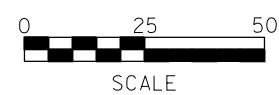
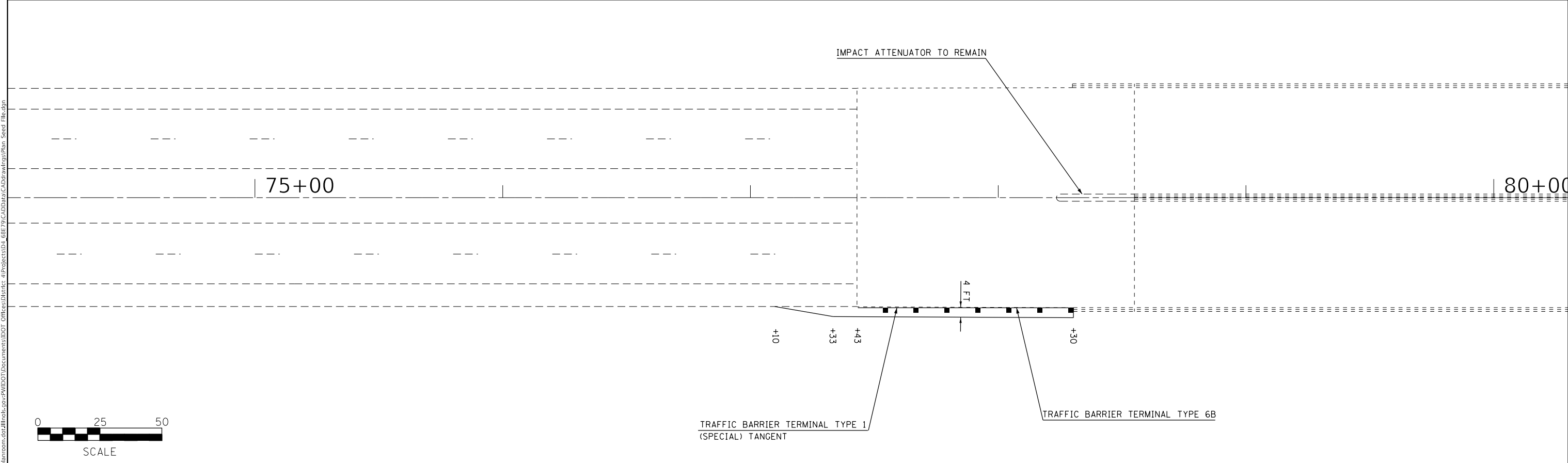
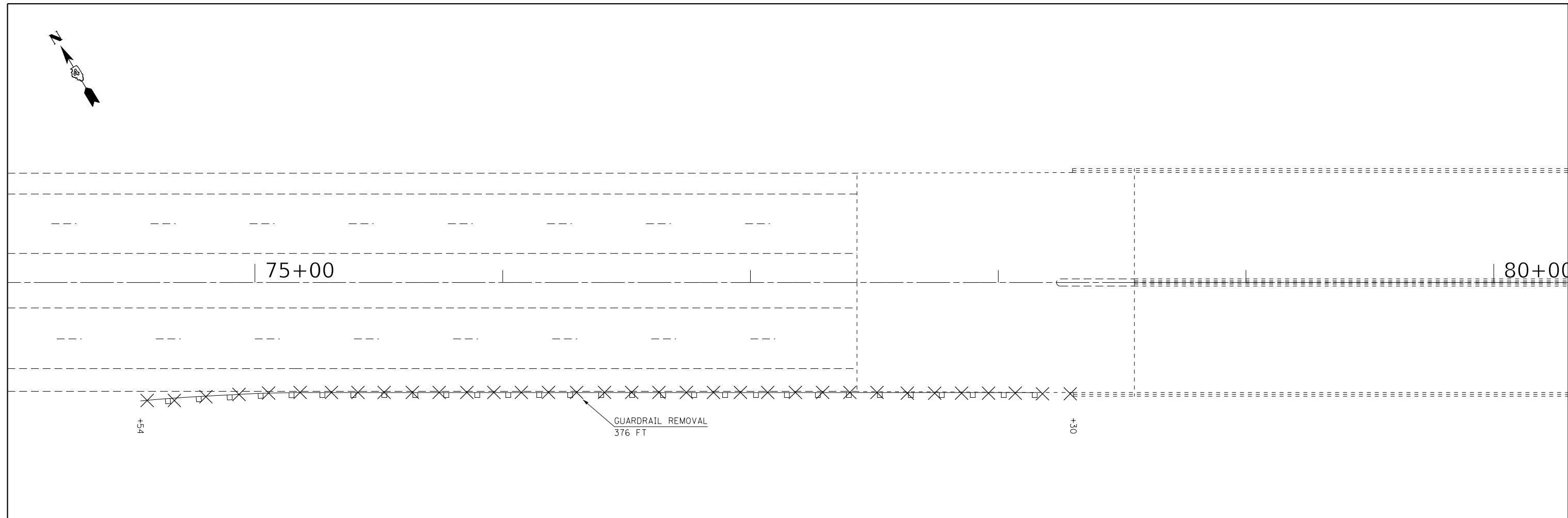
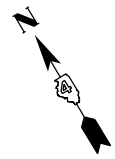
USER NAME = jochumsjg	DESIGNED -	REVISED -
PLOT SCALE = 50.0000 ' / in.	DRAWN -	REVISED -
PLOT DATE = 12/13/2019	CHECKED -	REVISED -
	DATE -	REVISED -

**STATE OF ILLINOIS  
DEPARTMENT OF TRANSPORTATION**

**PROPOSED TRAFFIC CONTROL  
STAGE 2**

SCALE: SHEET OF SHEETS STA. TO STA.

F.A.P. RTE.	SECTION	COUNTY	TOTAL SHEETS	SHEET NO.
693	(12B)BR,BDR,BJR	TAZEWELL	63	20
CONTRACT NO. 68E79				
ILLINOIS FED. AID PROJECT				



MODEL: h:\projects\6879\CADD\Drawings\Plan\_Seed Title.dgn  
 FILE NAME: p:\pub\barroom.dwg  
 ILLINOIS DOT OFFICE\DOT\Documents\DOT Office\Drawings\6879\CADD\Drawings\Plan\_Seed Title.dgn

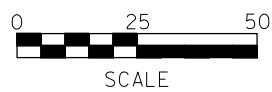
USER NAME = jochumsjg	DESIGNED -	REVISED -
DRAWN -	REVISOR -	
PLOT SCALE = 40.0000 ' / in.	CHECKED -	REVISED -
PLOT DATE = 12/13/2019	DATE -	REVISED -

**STATE OF ILLINOIS**  
**DEPARTMENT OF TRANSPORTATION**

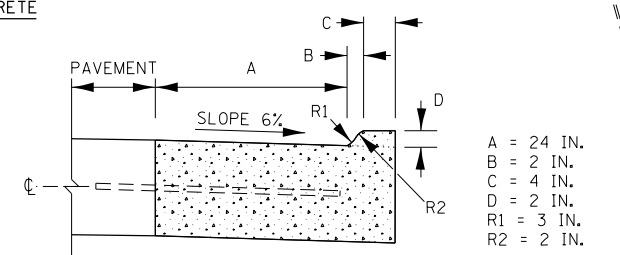
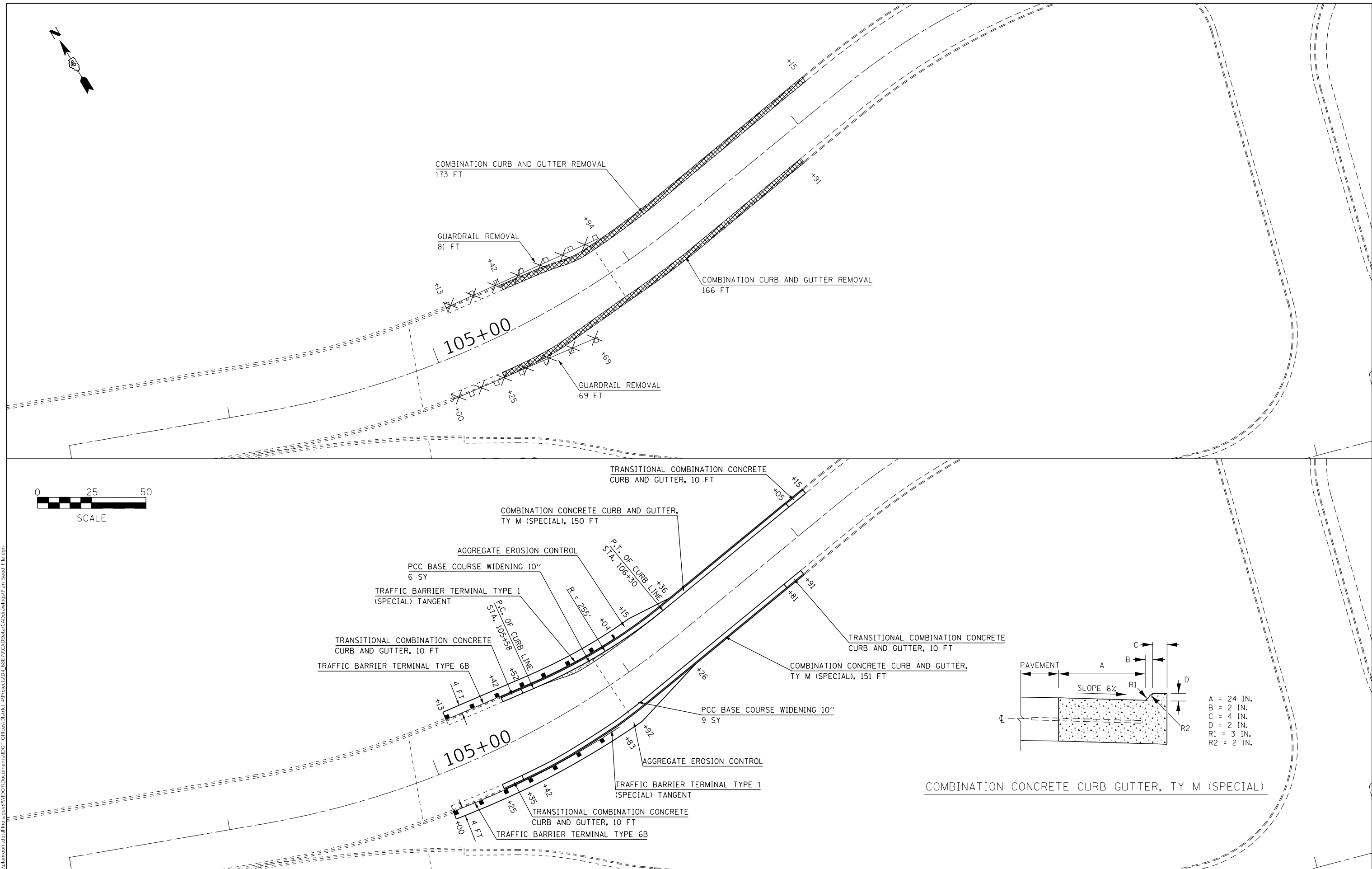
**GUARDRAIL DETAILS**  
**EXISTING & PROPOSED**

F.A.P. RTE.	SECTION	COUNTY	TOTAL SHEETS	SHEET NO.
693	(12B)BR,BDR,BJR	TAZEWELL	63	21
ILLINOIS FED. AID PROJECT			CONTRACT NO. 68E79	

SCALE: SHEET OF SHEETS STA. TO STA.



MODEL: streets  
 FILE: h:\mfc\_p\pub\barroom.dwg\illinois\dot\Documents\DOT\_Offices\Director\_of\Projects\04\_68E79\CADD\01\CAD\Drawings\Plan\_Seed\_1116.dgn



COMBINATION CONCRETE CURB GUTTER, TY M (SPECIAL)

USER NAME = jochumsjg	DESIGNED -	REVISED -
	DRAWN -	REVISED -
PLOT SCALE = 40.0000 ' / in.	CHECKED -	REVISED -
PLOT DATE = 12/13/2019	DATE -	REVISED -

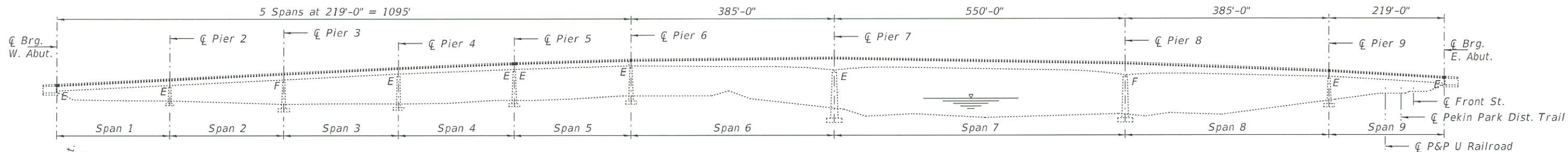
**STATE OF ILLINOIS**  
**DEPARTMENT OF TRANSPORTATION**

**GUARDRAIL DETAILS**  
**EXISTING & PROPOSED**

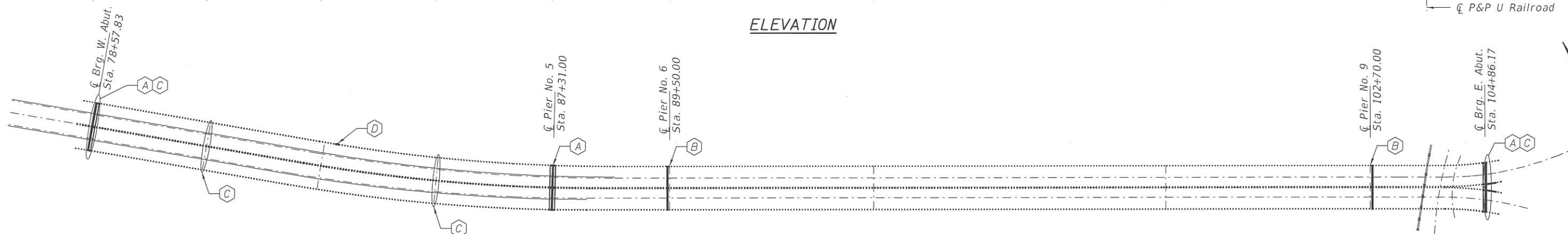
SCALE: SHEET OF SHEETS STA. TO STA.

F.A.P. RTE.	SECTION	COUNTY	TOTAL SHEETS	SHEET NO.
693	(128)BR,BDR,BJR	TAZEWELL	63	22
CONTRACT NO. 68E79				
ILLINOIS FED. AID PROJECT				

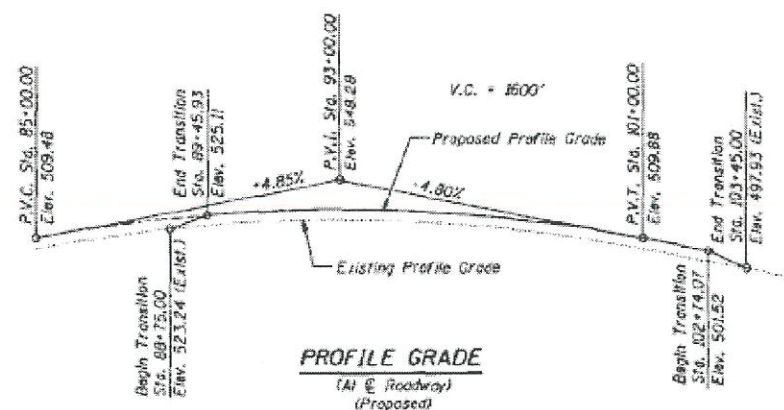




ELEVATION



PLAN



PROFILE GRADE  
(At Roadway)  
(Proposed)

CURVE DATA

P.I. Sta. 85+41.51  
P.C. Sta. 82+60.12  
P.T. Sta. 88+21.52  
 $\Delta = 9^{\circ}49'28.1''$   
 $D = 1^{\circ}45'00''$   
 $R = 3274.04'$   
 $L = 561.40'$   
 $S.E. = .05\%/ft.$

WESTBOUND  
CURVE DATA

P.I. Sta. 105+42.47  
P.C. Sta. 104+10.01  
P.T. Sta. 106+70.50  
 $\Delta = 25^{\circ}36'02''$   
 $D = 9^{\circ}49'40''$   
 $R = 563.00'$   
 $L = 132.46'$   
 $S.E. = .04\%/ft.$

EASTBOUND  
CURVE DATA

P.I. Sta. 104+89.50  
P.C. Sta. 104+10.04  
P.T. Sta. 105+67.99  
 $\Delta = 15^{\circ}31'22''$   
 $D = 9^{\circ}49'40''$   
 $R = 563.00'$   
 $L = 157.95'$   
 $S.E. = .04\%/ft.$

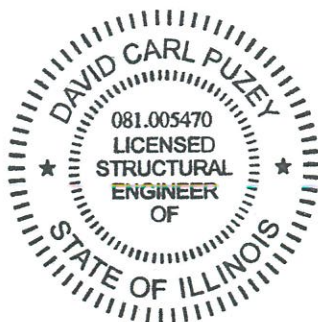
- (A) Remove and replace Modular Joint.
- (B) Remove and replace Preformed Joint Strip Seal.
- (C) Remove Rocker Bearings and replace with Pot Bearings.
- (D) Remove and replace concrete for light standard. See sheet 17 of 23 for details.

BOLT INSTALLATION REPAIR

NBIS ITEM	SPAN	MEMBER / LOCATION	DEFFICIENCY
71	2	Drain @ G8 Btwn. FB. 3 & 4	2 broken bolts in brkt.
54	2	G6 Bot. Flg. Splice PL. Btwn. FB. 7 & 8	1 Loose Bolt
55	2	Str. 1 Bot. Flg. Splice PL. Btwn. FB. 7 & 8	1 Loose Bolt
36	2	FB. 8 South Conn. PL. of FB. 8 @ G8	4 Loose Bolts
74	3	FB. 6 @ G6 Inside Bot. Conn. PL	1 Missing Bolt
37	3	Drain @ G5 Btwn. FB. 7 & 8	2 bolts broken on brkt. Connecting to G5
56	3	Catwalk, Hanger Conn. @ FB. 8 Btwn. S8 & S9	1 Missing Bolt
83	4	G5 @ FB. 10, P5	1 Loose Bolt, Bot. Flg. To Conn. PL
39	5	Drain @ G12 Btwn. FB. 7 & 8	2 Missing Bolts and Missing Brkt.
58	5	Catwalk, N. Rail, 3rd Post from P6	1 Missing Bolt & Hole Misaligned Btwn. S7 & S8
60	6	G3 Box Gir. Pan. 4, S Web, Top Stiff @ Web Splice	1 Loose Bolt
61	6	G4 Box Gir. Pan. 7, Bot. Flg. @ Splice	1 Missing Bolt
62	6	G2 Bos Gir. Pan. 10, Top of N. Web Splice	1 Missing Bolt
41	6	G4 Box Gir. Pan. 13, N Web @ Splice	1 Loose Nut at Splice
63	6	G3 Box Gir. Pan. 13, S Web, 3rd from Bot. Stiff. @ Web Splice	1 Loose Bolt at Splice
94	6	G1 Box Gir. Pan. 13, S Web, @ Web Splice	1 Loose Bolt @ Horiz. Stiff. Splice
64	6	G1 Box Gir. Pan. 19, S Web, Top Stiff. @ Web Splice	1 Loose Bolt @ Splice
65	6	G4 Box Gir. Pan. 19, Bot. Flg., Stiff. @ Web Splice	11 Loose Nuts, 1 Missing Bolt and 1 Missing Nut at Splice
66	7	G3 Box Gir. Pan. 23, N Web, 2nd Stiff. From Floor, Web Splice	1 Loose Nut at Splice
52	8,9	Brg. NW Anchor Bolt Below G4 @ P9	Nut is Loose
16	7,8	G2 Brg. @ P8	2 bolts missing
98	7,8	G3 Brg. @ P8	3 loost nuts

GENERAL NOTES

All structural steel shall conform to AASHTO Classification M-270 Gr. 36, unless otherwise noted.  
 Reinforcement bars designated (E) shall be epoxy coated.  
 Fasteners shall be high strength bolts. Bolts 7/8"Ø, open holes 1 1/16"Ø, unless otherwise noted.  
 Prior to pouring the new concrete deck, all heavy or loose rust, loose mill scale, and other loose or potentially detrimental foreign material shall be removed from the surfaces in contact with concrete. Tightly adhered paint may remain unless otherwise noted. Removal shall be accomplished by methods that will not damage the steel and the cost will be included in the pay item covering removal of the existing concrete.  
 Plan dimensions and details relative to existing plans are subject to nominal construction variations. The Contractor shall field verify existing dimensions and details affecting new construction and make necessary approved adjustments prior to construction or ordering of materials. Such variations shall not be cause for additional compensation for a change in scope of the work, however, the Contractor will be paid for the quantity actually furnished at the unit price bid for the work.  
 Existing reinforcement bars extending into the removal area shall be cleaned, straightened and incorporated into the new construction. Any reinforcement bars that are damaged during concrete removal shall be replaced with an approved bar splicer or anchorage system. Cost included with Concrete Removal.  
 The deck surface shall have its final finish tined according to Article 420.09(e)(1) of the Standard Specifications. Cost included with Concrete Superstructure.  
 Areas of deck repairs shown are estimated. The Engineer shall show actual locations of deck repairs on As-built Plans.  
 Joint openings shall be adjusted according to Article 520.04 of the Std. Specs. when the deck is poured at an ambient temperature other than 50° F.  
 New bearing plates, steel extensions, shim plates, side retainers, anchor bolts, connection bolts, nuts and washers shall be hot-dip galvanized. See Special Provisions for "Hot Dip Galvanizing For Structural Steel".



EXPIRES 11-30-2020

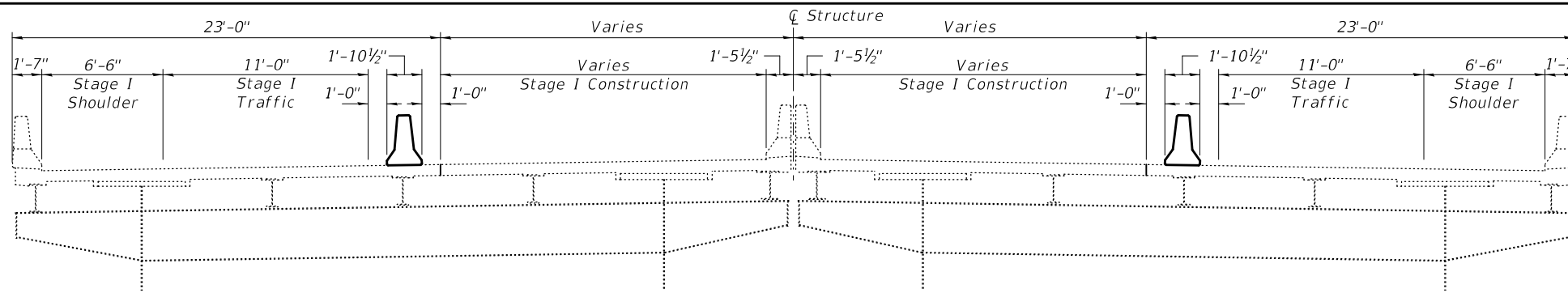
DESIGNED - [Signature]	EXAMINED - [Signature]	DATE - JANUARY 31, 2020
CHECKED - [Signature]	PASSED - [Signature]	REVISER -
DRAWN - [Signature]	ENGINEER OF BRIDGES AND STRUCTURES	REVISER -
CHECKED - [Signature]	ENGINEER OF STRUCTURAL SERVICES	

STATE OF ILLINOIS  
DEPARTMENT OF TRANSPORTATION

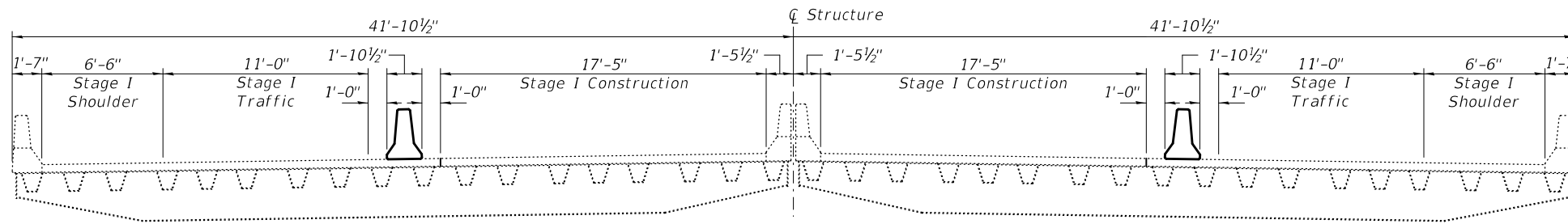
GENERAL PLAN AND ELEVATION  
IL 9 OVER ILLINOIS RIVER  
SN 090-0114

SHEET NO. 1 OF 23 SHEETS

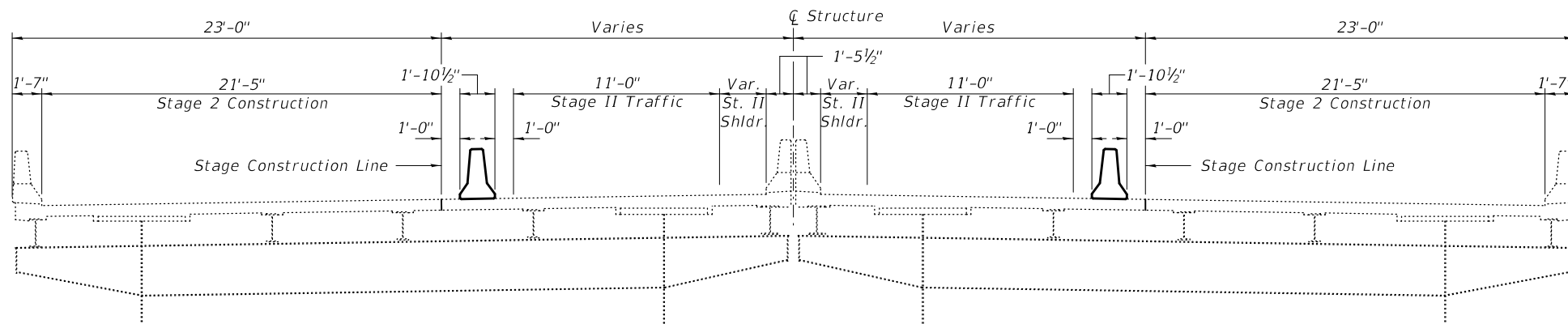
F.A.P. RTE.	SECTION	COUNTY	TOTAL SHEETS	SHEET NO.
693	(12B)BR,BDR,BJR	PEORIA	63	23
CONTRACT NO. 68E79				
ILLINOIS FED. AID PROJECT				



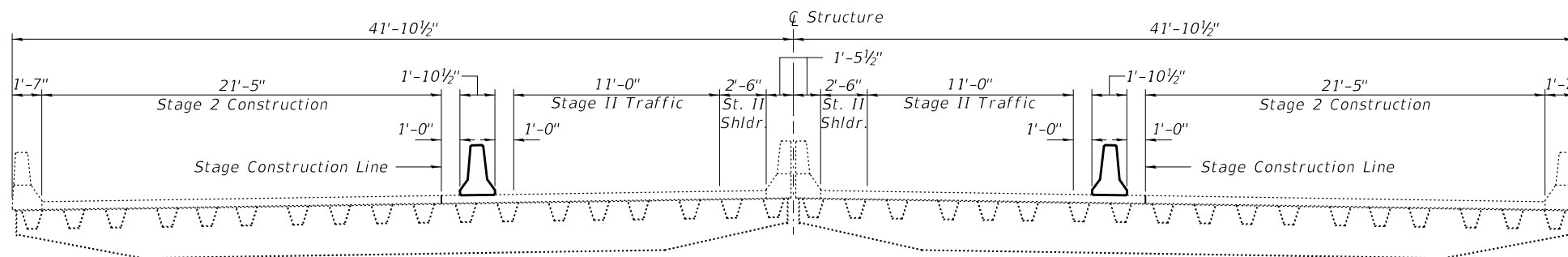
**TYPICAL SECTION THRU APPROACH SPANS 1-5 & 9**  
(Looking East)



**TYPICAL SECTION THRU MAIN RIVER SPANS 6, 7, 8**  
(Looking East)



**TYPICAL SECTION THRU APPROACH SPANS 1-5, 9**  
(Looking East)



**TYPICAL SECTION THRU MAIN RIVER SPANS 6, 7, 8**  
(Looking East)

**TOTAL BILL OF MATERIAL**

ITEM	UNIT	QUANTITY
Concrete Removal	Cu. Yd.	113.6
Concrete Structures	Cu. Yd.	25.5
Concrete Superstructure	Cu. Yd.	118.2
Reinforcement Bars, Epoxy Coated	Pound	21330
Protective Coat	Sq. Yd.	235
Bar Splicers	Each	124
Mechanical Splicers	Each	388
Anchor Bolts 1 1/4"	Each	20
Anchor Bolts 1 1/2"	Each	80
Dowel Bars, 5/8"	Each	8
Modular Expansion Joint 6"	Foot	90
Modular Expansion Joint 9"	Foot	93
Modular Expansion Joint 18"	Foot	84
Preformed Joint Strip Seal	Foot	164
Structural Repair of Concrete (Depth ≤ 5")	Sq. Ft.	262
Deck Slab Repair (Partial)	Sq. Yd.	140
Jack and Remove Existing Bearings	Each	16
High Load Multi-Rotational Bearings, Guided Expansion, 650k	Each	4
High Load Multi-Rotational Bearings, Guided Expansion, 700k	Each	4
High Load Multi-Rotational Bearings, Guided Expansion, 1700k	Each	4
High Load Multi-Rotational Bearings, Guided Expansion, 1900k	Each	4
Structural Steel Removal	Pound	110
Structural Steel Repair	Pound	50
Structural Repair of Concrete (Depth > 5")	Sq. Ft.	524

\* On new concrete adjacent to joints and new light standard only.  
 \*\* Installation of missing bolts.  
 \*\*\* Quantity includes deck repair on spans 1 thru 5 and 9.

DESIGNED - AJR  
 CHECKED - JSB  
 DRAWN - daburdell  
 CHECKED - AJR JSB

EXAMINED  
 PASSED  
 ENGINEER OF STRUCTURAL SERVICES  
 ENGINEER OF BRIDGES AND STRUCTURES

DATE - JANUARY 31, 2020  
 REVISED -  
 REVISED -

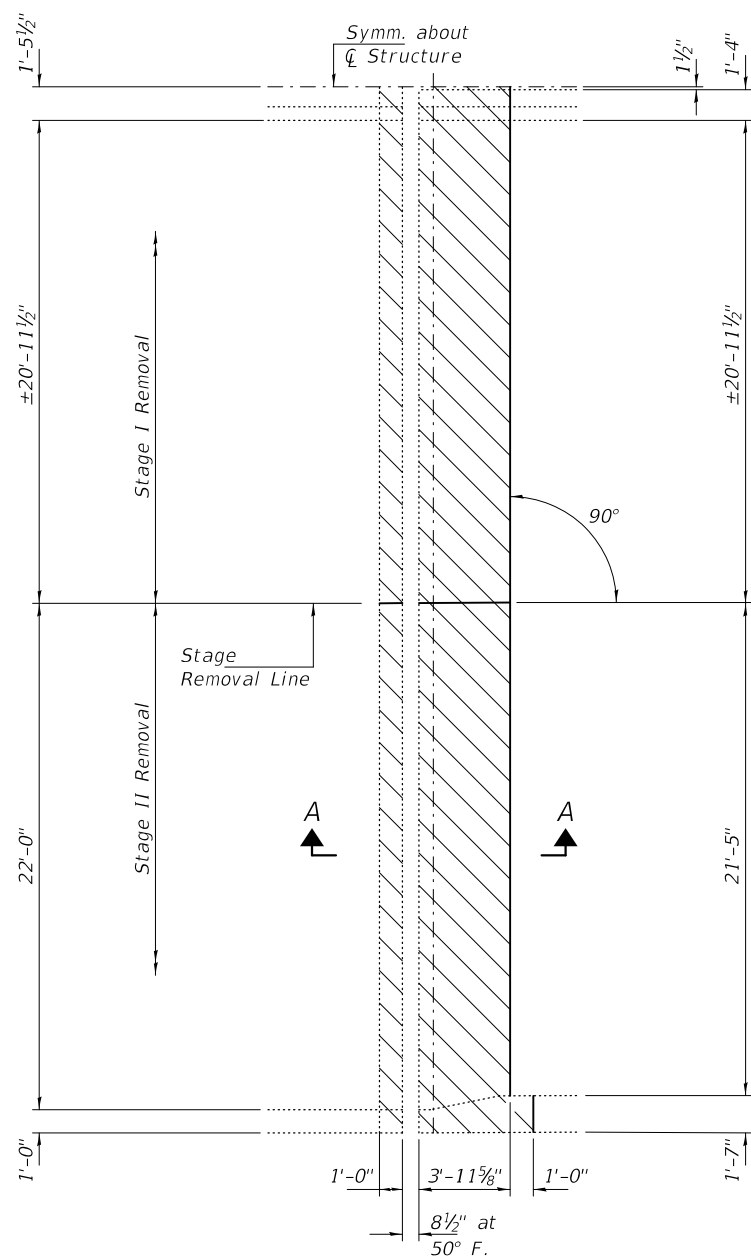
STATE OF ILLINOIS  
 DEPARTMENT OF TRANSPORTATION

STAGE CONSTRUCTION DETAILS  
 SN 090-0114

SHEET NO. 2 OF 23 SHEETS

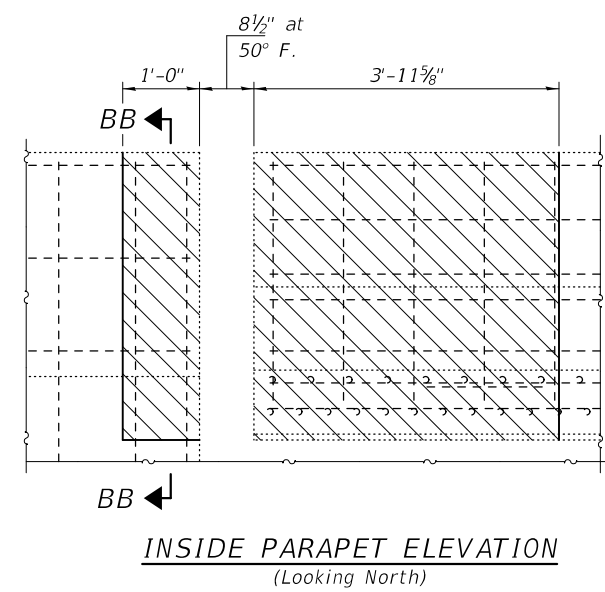
F.A.P. RTE.	SECTION	COUNTY	TOTAL SHEETS	SHEET NO.
693	(12B)BR,BDR,BJR	PEORIA	63	24
CONTRACT NO. 68E79			ILLINOIS FED. AID PROJECT	



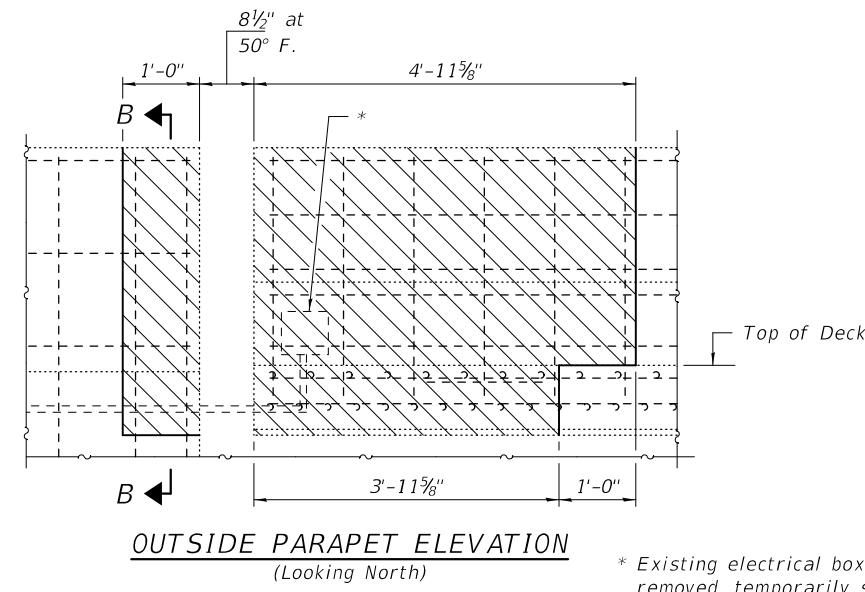


**CONCRETE REMOVAL DETAILS**  
(West Abutment - E.B. shown,  
W.B. typ. by mirroring)

Note:  
Hatched areas indicate  
Concrete Removal.

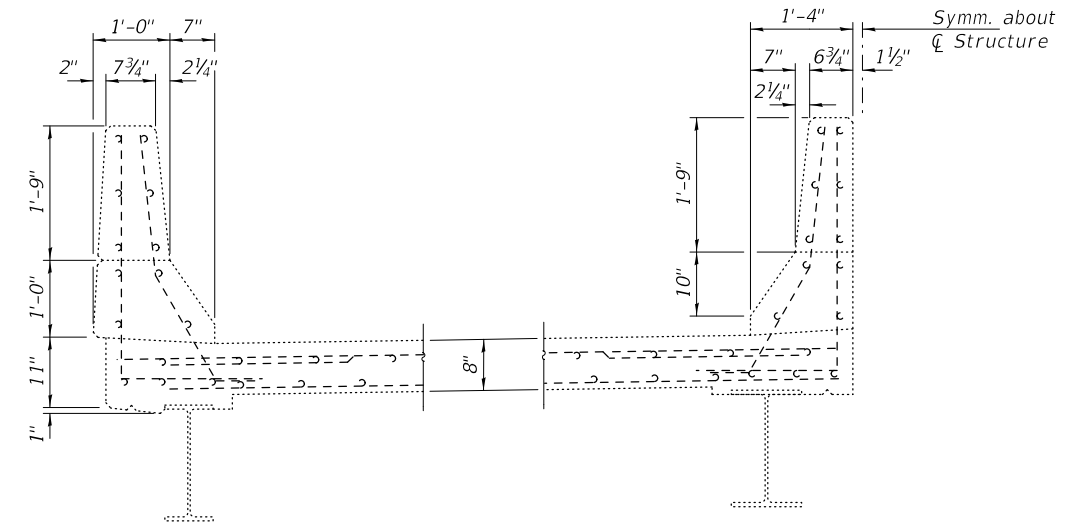


**INSIDE PARAPET ELEVATION**  
(Looking North)

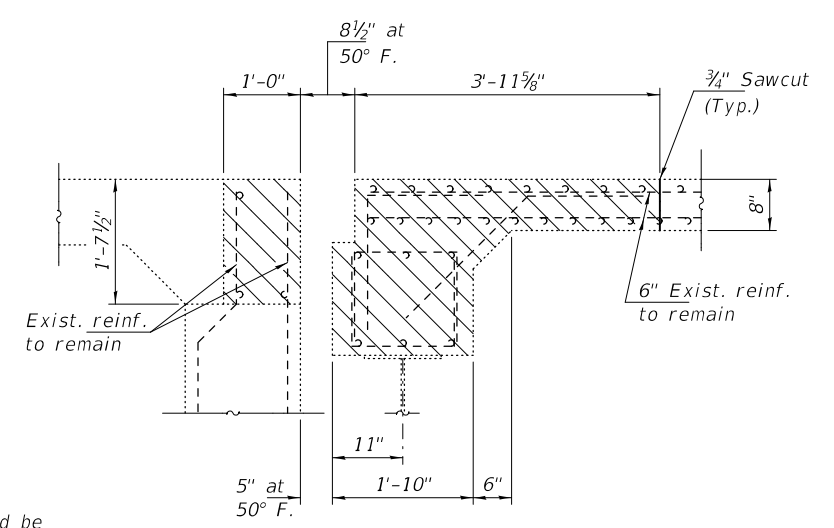


**OUTSIDE PARAPET ELEVATION**  
(Looking North)

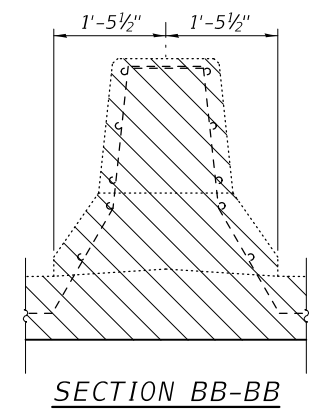
\* Existing electrical box should be removed, temporarily supported and reattached after concrete work is completed.



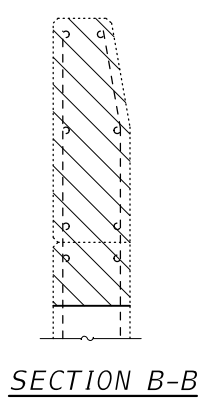
**SECTION THRU PARAPETS**



**SECTION A-A**



**SECTION BB-BB**



**SECTION B-B**

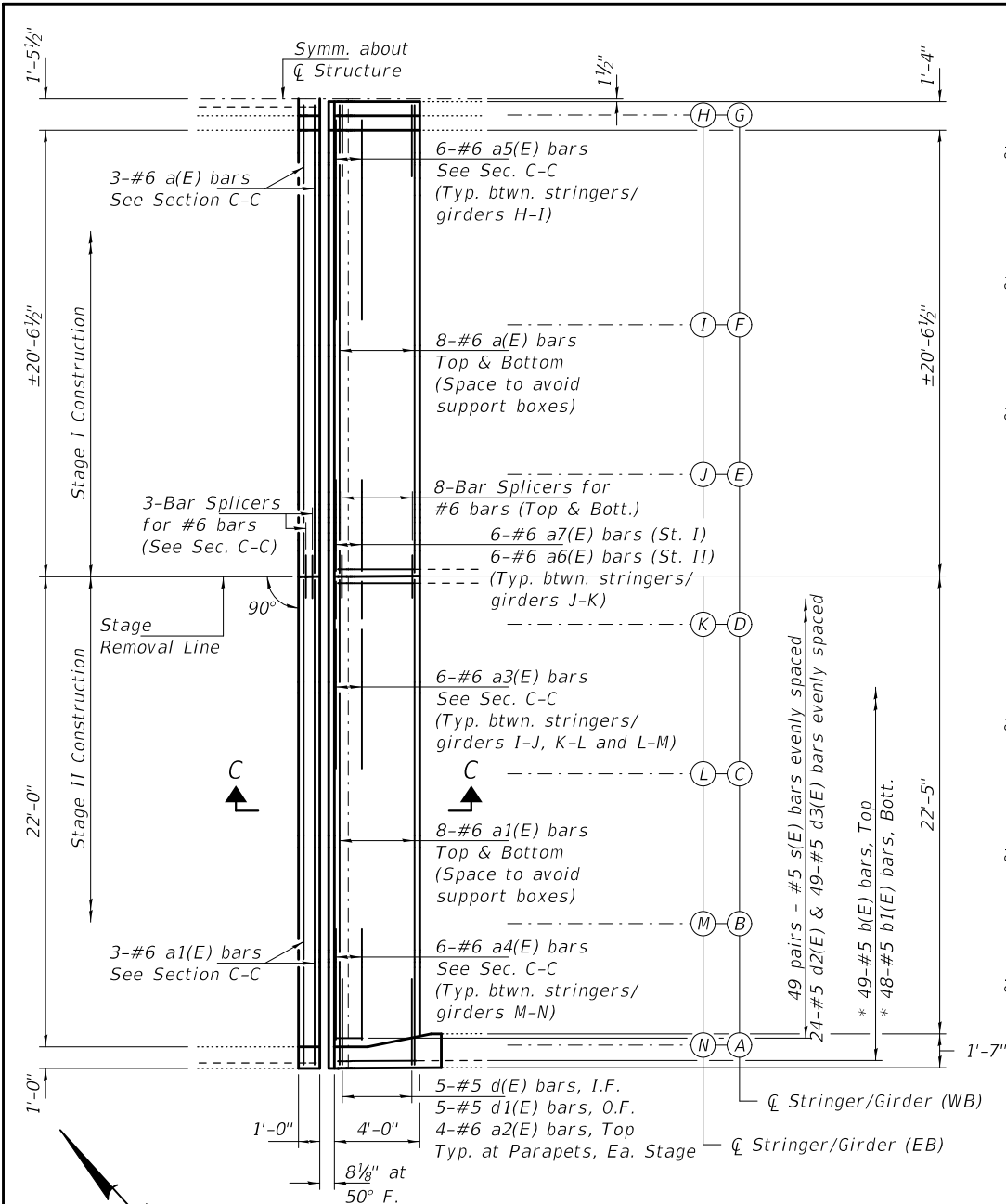
DESIGNED - AJR	EXAMINED - <i>Timothy A. Daburdell</i>	DATE - JANUARY 31, 2020
CHECKED - JSB	ENGINEER OF STRUCTURAL SERVICES	
DRAWN - <i>daburdell</i>	PASSED - <i>Carl Pinger</i>	REVISED -
CHECKED - AJR JSB	ENGINEER OF BRIDGES AND STRUCTURES	REVISED -

**STATE OF ILLINOIS**  
**DEPARTMENT OF TRANSPORTATION**

**JOINT REMOVAL - WEST ABUTMENT**  
**SN 090-0114**

SHEET NO. 3 OF 23 SHEETS

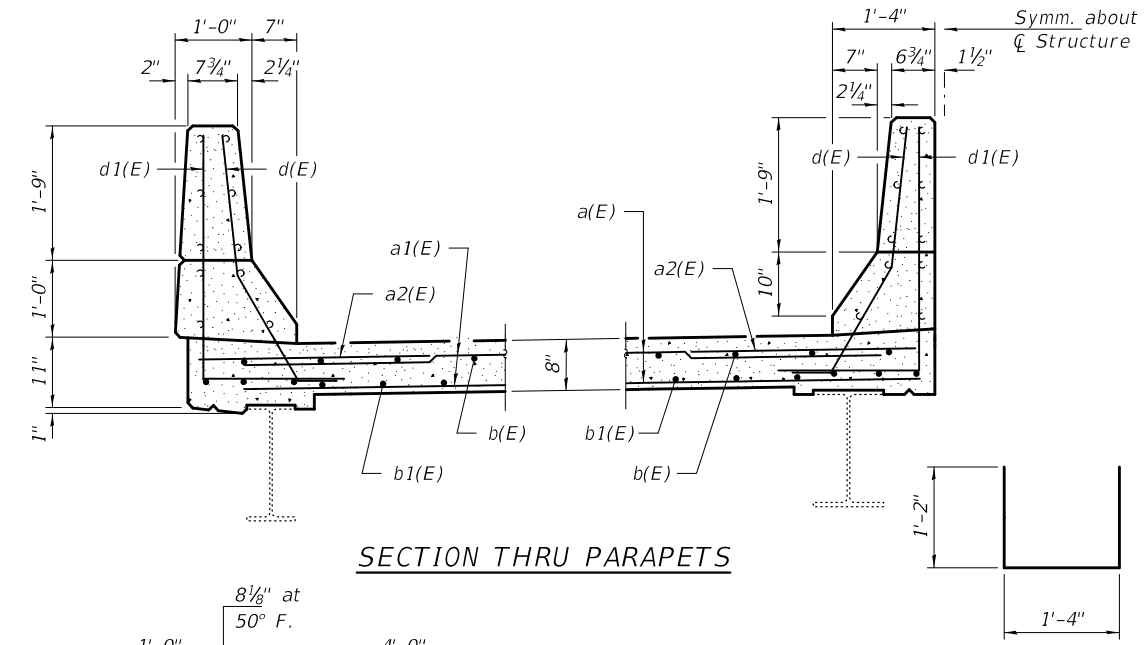
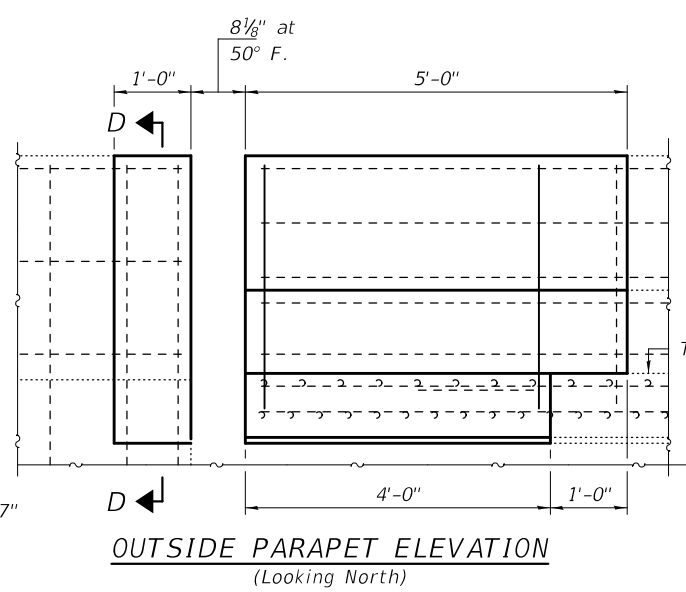
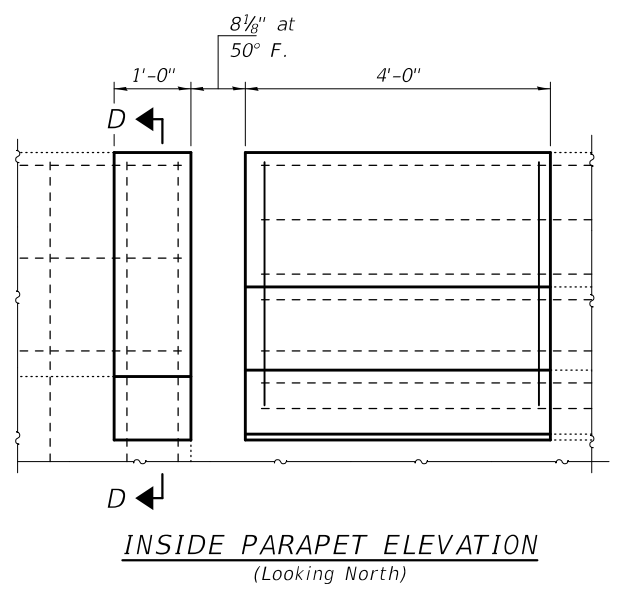
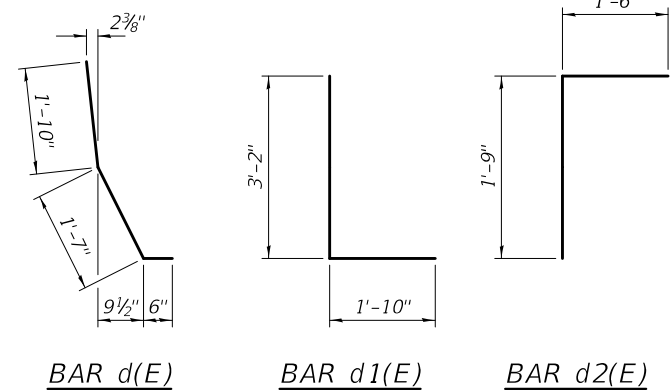
F.A.P. RTE.	SECTION	COUNTY	TOTAL SHEETS	SHEET NO.
693	(12B)BR,BDR,BJR	PEORIA	63	25
CONTRACT NO. 68E79				
ILLINOIS FED. AID PROJECT				



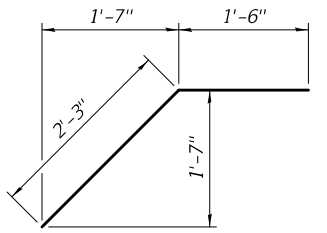
**CONCRETE REPLACEMENT DETAILS**

(West Abutment - E.B. shown, W.B. typ. by mirroring)

Note: Place d2(E) bars between modular jt. support boxes.



**BAR s(E)**



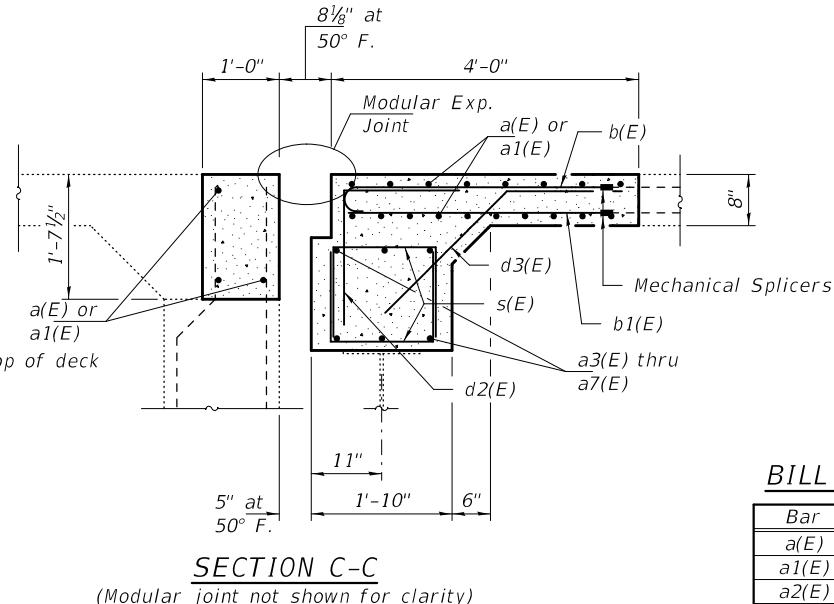
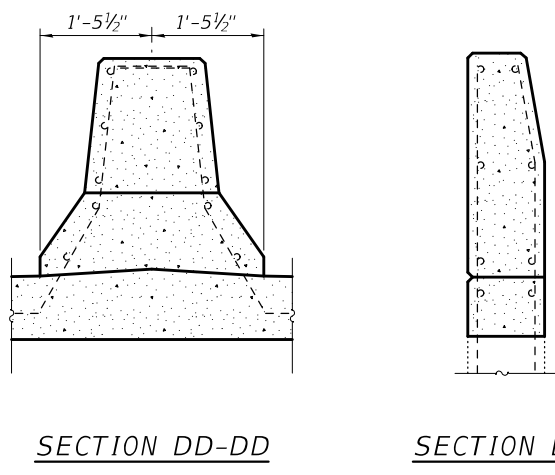
**BAR d3(E)**

**BILL OF MATERIAL - W. ABUT.**

Bar	No.	Size	Length	Shape
a(E)	32	#6	21'-6"	—
a1(E)	32	#6	22'-8"	—
a2(E)	16	#6	4'-0"	—
a3(E)	36	#6	6'-8"	—
a4(E)	12	#6	5'-4"	—
a5(E)	12	#6	9'-4"	—
a6(E)	12	#6	1'-9"	—
a7(E)	12	#6	4'-3"	—
b(E)	98	#5	3'-11"	┌
b1(E)	96	#5	3'-4"	—
d(E)	20	#5	3'-11"	└
d1(E)	20	#5	5'-0"	┌
d2(E)	48	#5	3'-3"	└
d3(E)	98	#5	3'-9"	└
s(E)	196	#5	3'-8"	└

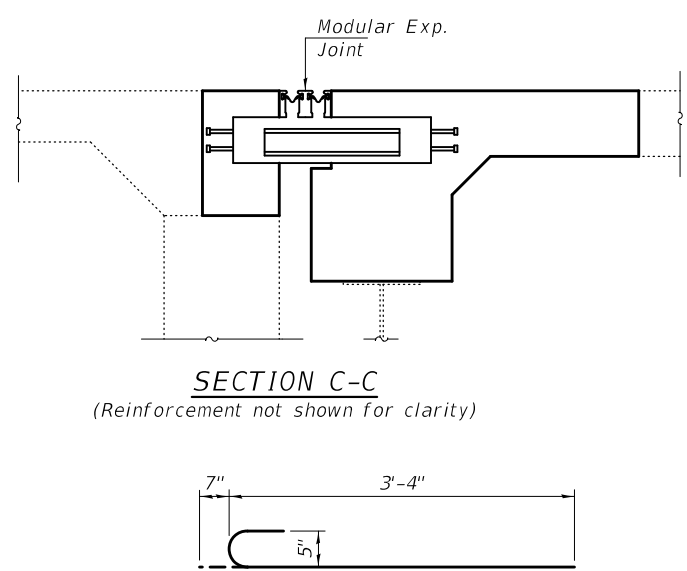
Concrete Removal	Cu. Yd.	27.0
Concrete Superstructure	Cu. Yd.	27.1
Bar Splicers	Each	38
Mechanical Splicers	Each	194
Protective Coat	Sq. Yd.	62
Modular Expansion Joint, 6"	Foot	90
Reinforcement Bars, Epoxy Coated	Pound	5170

Placement of reinforcement within the joint block out needs to be coordinated with the joint manufacturer.



**SECTION C-C**

(Modular joint not shown for clarity)



**SECTION C-C**

(Reinforcement not shown for clarity)

**BAR b(E)**

DESIGNED - AJR  
 CHECKED - JSB  
 DRAWN - daburdell  
 CHECKED - AJR JSB

EXAMINED  
 PASSED  
 ENGINEER OF BRIDGES AND STRUCTURES

DATE - JANUARY 31, 2020  
 REVISED -  
 REVISED -

STATE OF ILLINOIS  
 DEPARTMENT OF TRANSPORTATION

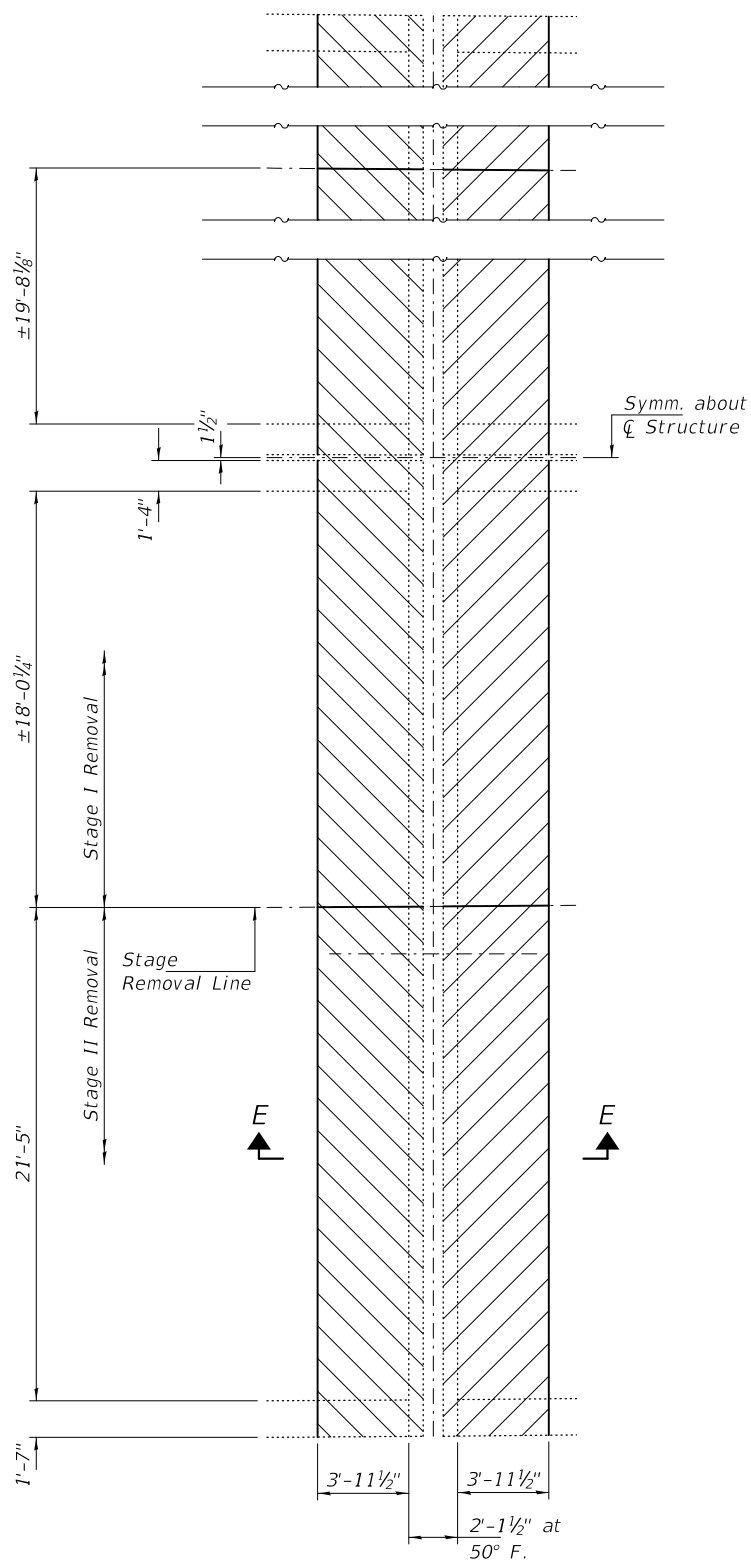
JOINT REPLACEMENT - WEST ABUTMENT  
 SN 090-0114

SHEET NO. 4 OF 23 SHEETS

F.A.P. RTE.	SECTION	COUNTY	TOTAL SHEETS	SHEET NO.
693	(12B)BR,BDR,BJR	PEORIA	63	26
				CONTRACT NO. 68E79

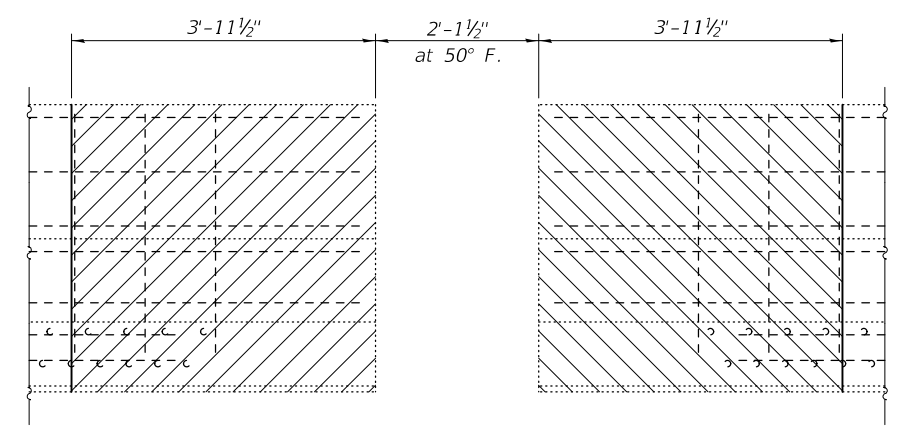
ILLINOIS FED. AID PROJECT



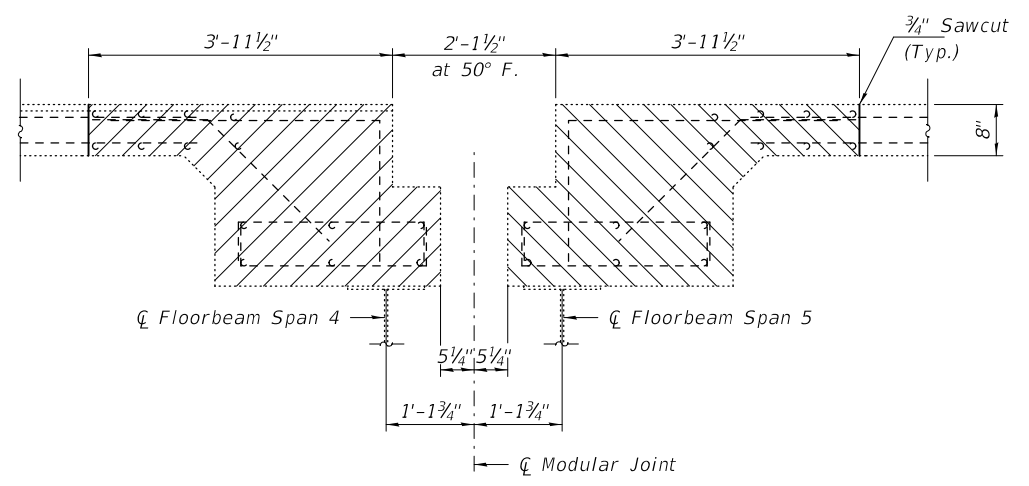


**CONCRETE REMOVAL DETAILS**  
 (Pier 5 - E.B. shown,  
 W.B. typ. by mirroring,  
 except as noted.)

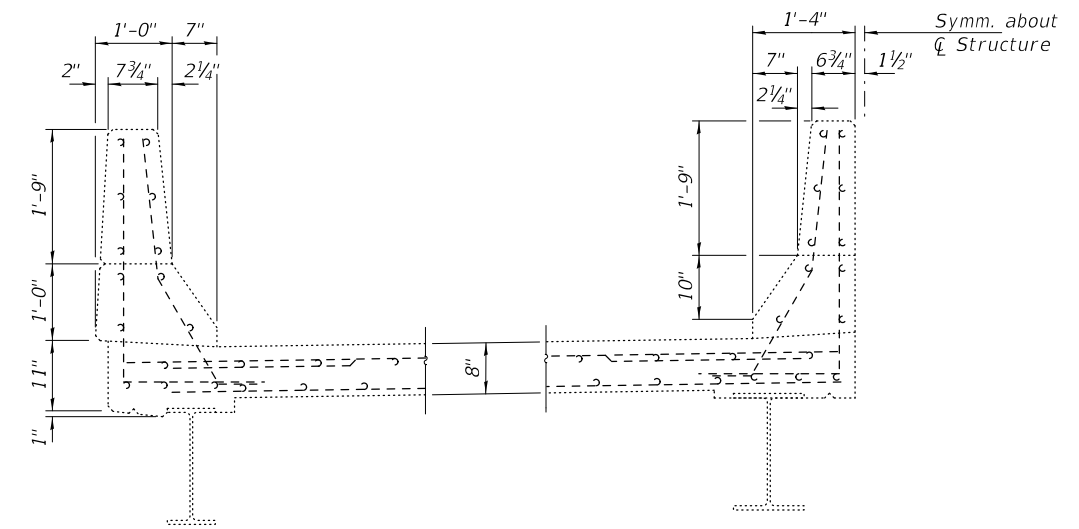
Note:  
 Hatched areas indicate  
 Concrete Removal.



**PARAPET ELEVATION**



**SECTION E-E**



**SECTION THRU PARAPETS**

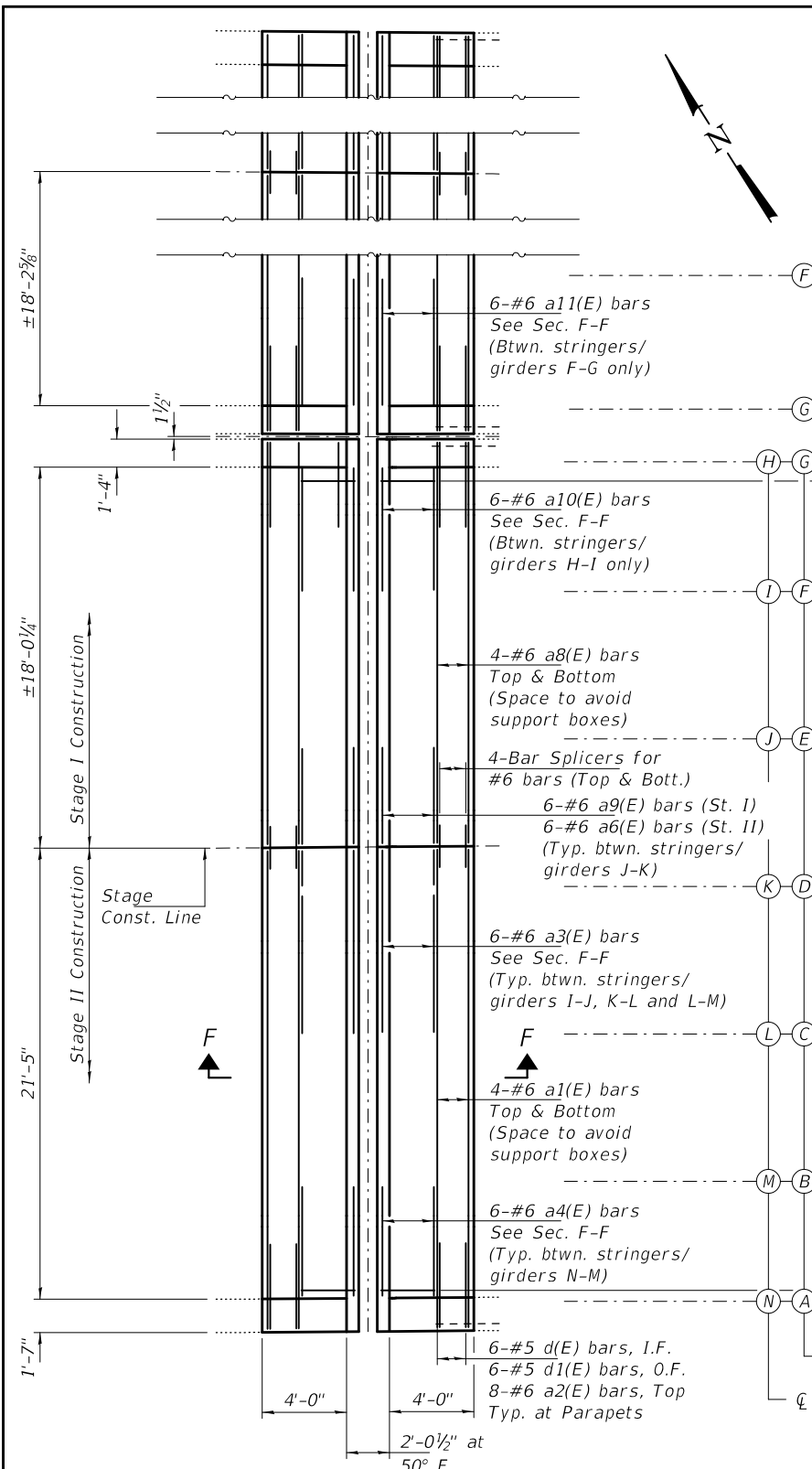
DESIGNED - AJR	EXAMINED - <i>Timothy A. Daulton</i> ENGINEER OF STRUCTURAL SERVICES	DATE - JANUARY 31, 2020
CHECKED - JSB	PASSED - <i>Carl R. Roper</i> ENGINEER OF BRIDGES AND STRUCTURES	REVISED -
DRAWN - daburdell		REVISED -
CHECKED - AJR JSB		

**STATE OF ILLINOIS  
 DEPARTMENT OF TRANSPORTATION**

**JOINT REMOVAL - PIER 5  
 SN 090-0114**

SHEET NO. 5 OF 23 SHEETS

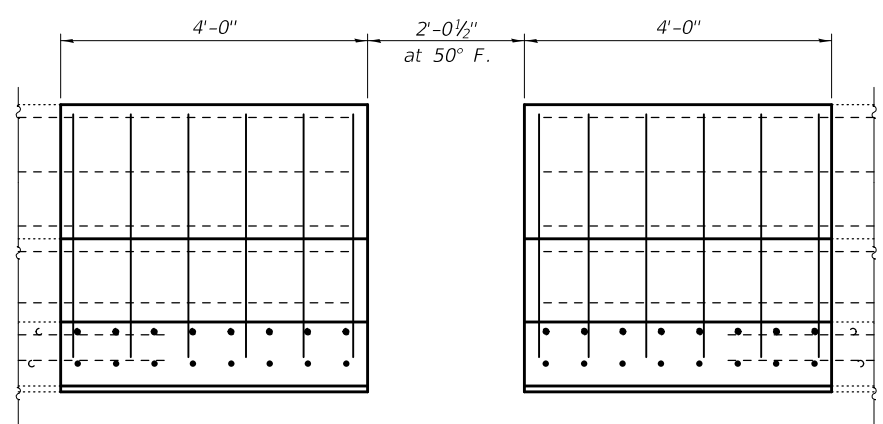
F.A.P. RTE.	SECTION	COUNTY	TOTAL SHEETS	SHEET NO.
693	(12B)BR,BDR,BJR	PEORIA	63	27
CONTRACT NO. 68E79			ILLINOIS FED. AID PROJECT	



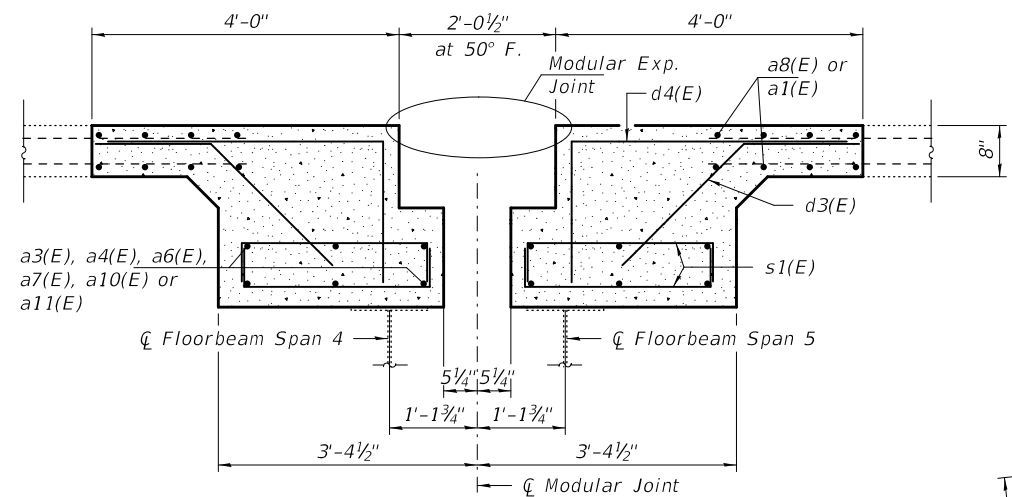
**CONCRETE REPLACEMENT DETAILS**

(Pier 5 - E.B. shown, W.B. typ. by mirroring, except as noted.)

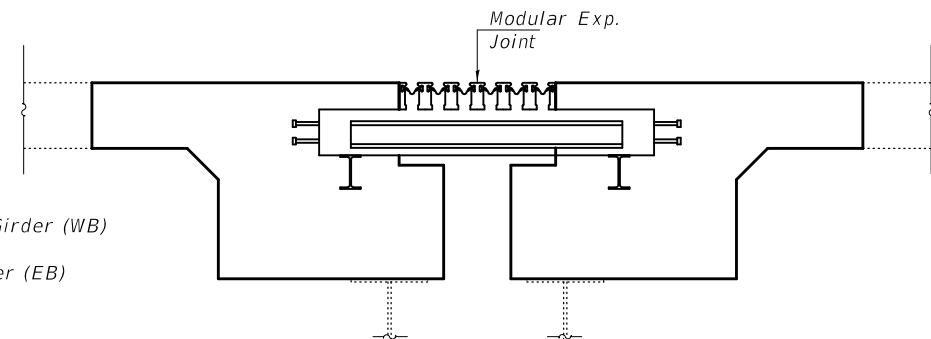
Note:  
All reinforcement typ. each side of joint.  
Place d4(E) bars between Modular jt. support boxes



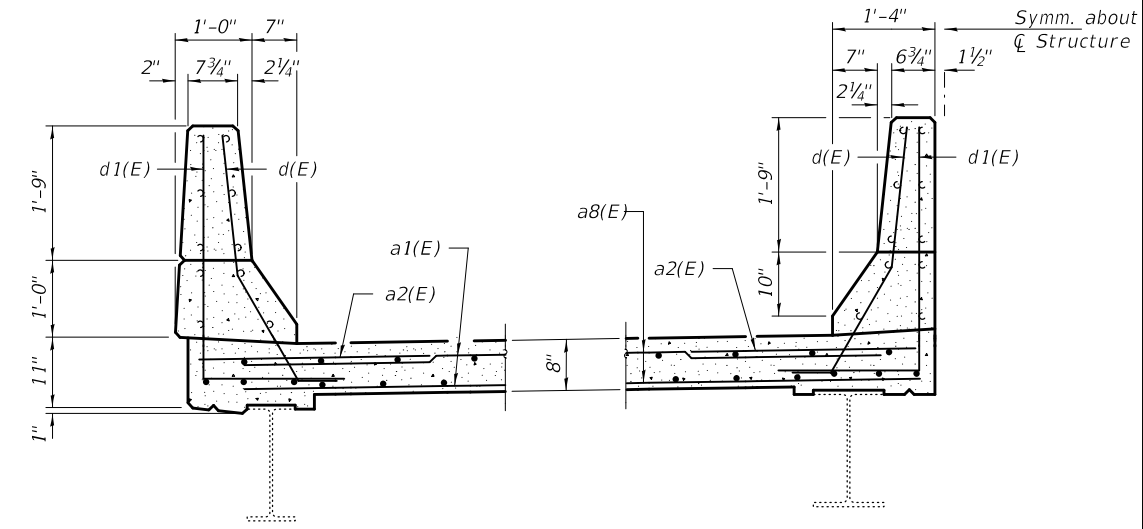
**PARAPET ELEVATION**



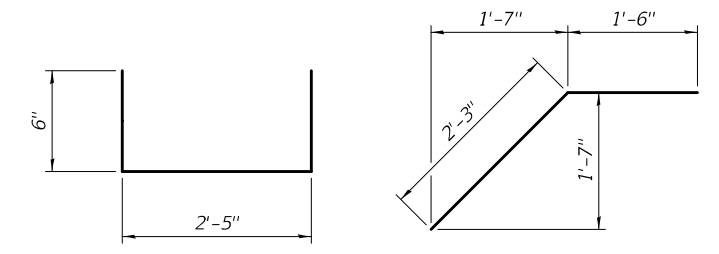
**SECTION F-F**  
(Modular joint not shown for clarity)



**SECTION F-F**  
(Reinforcement not shown for clarity)

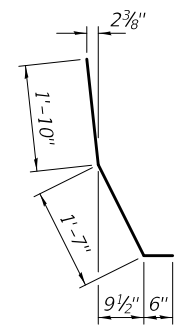


**SECTION THRU PARAPETS**

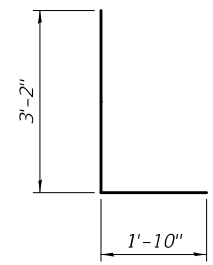


**BAR s1(E)**

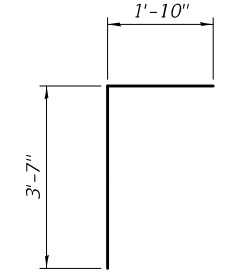
**BAR d3(E)**



**BAR d(E)**



**BAR d1(E)**



**BAR d4(E)**

**BILL OF MATERIAL - PIER 5**

Bar	No.	Size	Length	Shape
a1(E)	32	#6	22'-8"	—
a2(E)	64	#6	4'-0"	—
a3(E)	72	#6	6'-8"	—
a4(E)	24	#6	5'-4"	—
a6(E)	24	#6	1'-9"	—
a7(E)	24	#6	4'-7"	—
a8(E)	32	#6	17'-8"	—
a10(E)	12	#6	7'-2"	—
a11(E)	12	#6	7'-4"	—
d(E)	48	#5	3'-11"	↘
d1(E)	48	#5	5'-0"	L
d3(E)	176	#5	3'-9"	↗
d4(E)	88	#5	5'-5"	┌
s1(E)	320	#5	3'-5"	└
Concrete Removal		Cu. Yd.	49.9	
Concrete Superstructure		Cu. Yd.	50.2	
Bar Splicers		Each	32	
Protective Coat		Sq. Yd.	83	
Modular Expansion Joint, 18"		Pound	6500	
Reinforcement Bars, Epoxy Coated		Foot	84	

Placement of reinforcement within the joint block out needs to be coordinated with the joint manufacturer.

DESIGNED - AJR  
CHECKED - JSB  
DRAWN - daburdell  
CHECKED - AJR JSB

EXAMINED  
PASSED  
Timothy A. [Signature]  
ENGINEER OF STRUCTURAL SERVICES  
[Signature]  
ENGINEER OF BRIDGES AND STRUCTURES

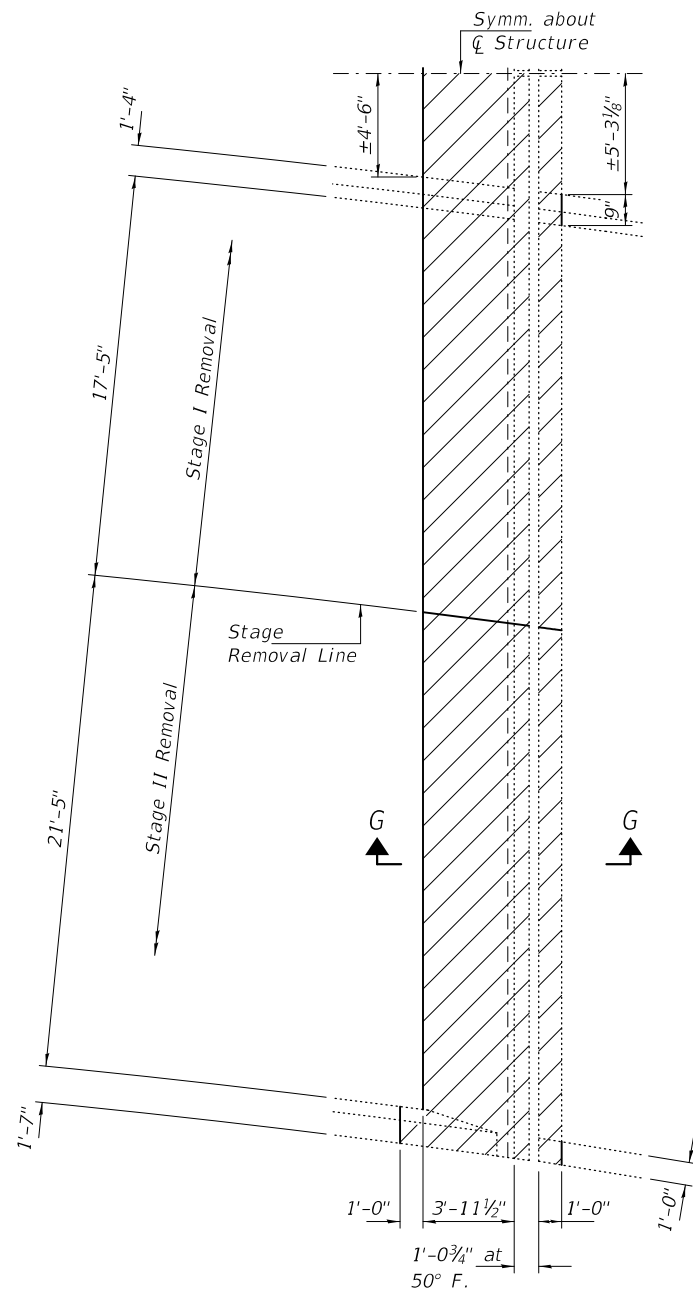
DATE - JANUARY 31, 2020  
REVISED -  
REVISED -

STATE OF ILLINOIS  
DEPARTMENT OF TRANSPORTATION

JOINT REPLACEMENT - PIER 5  
SN 090-0114

SHEET NO. 6 OF 23 SHEETS

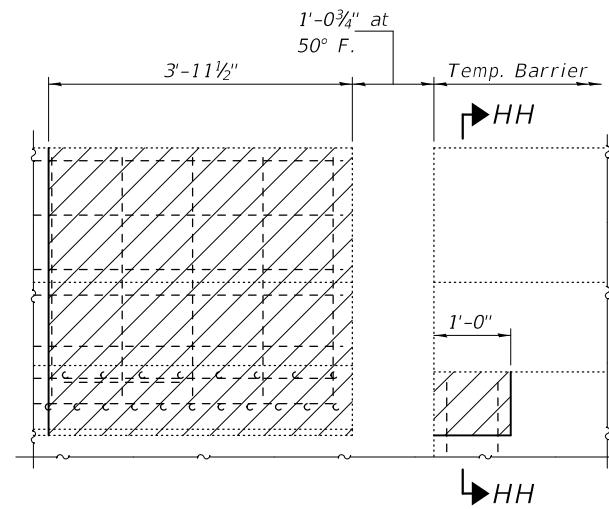
F.A.P. RTE.	SECTION	COUNTY	TOTAL SHEETS	SHEET NO.
693	(12B)BR,BDR,BJR	PEORIA	63	28
			CONTRACT NO. 68E79	
ILLINOIS FED. AID PROJECT				



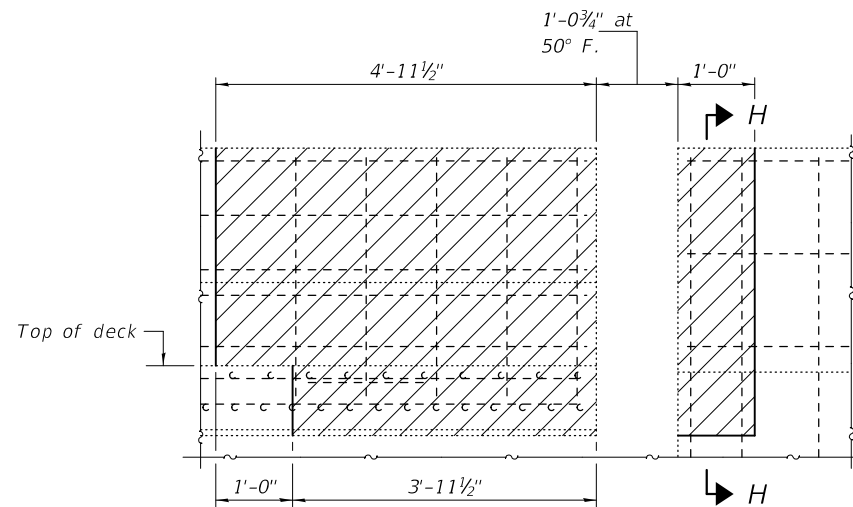
**CONCRETE REMOVAL DETAILS**

(East Abutment - E.B. shown,  
W.B. typ. by mirroring)

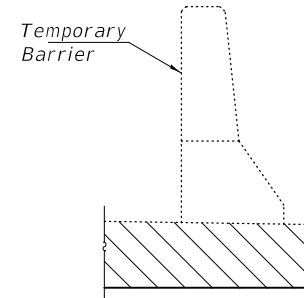
Note:  
Hatched areas indicate  
Concrete Removal.



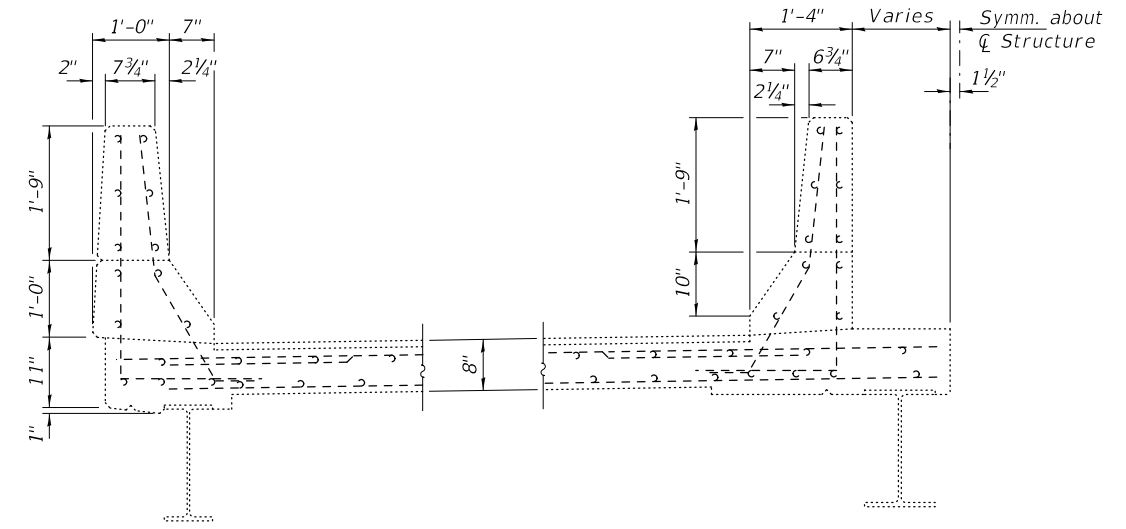
**INSIDE PARAPET ELEVATION**  
(Looking North)



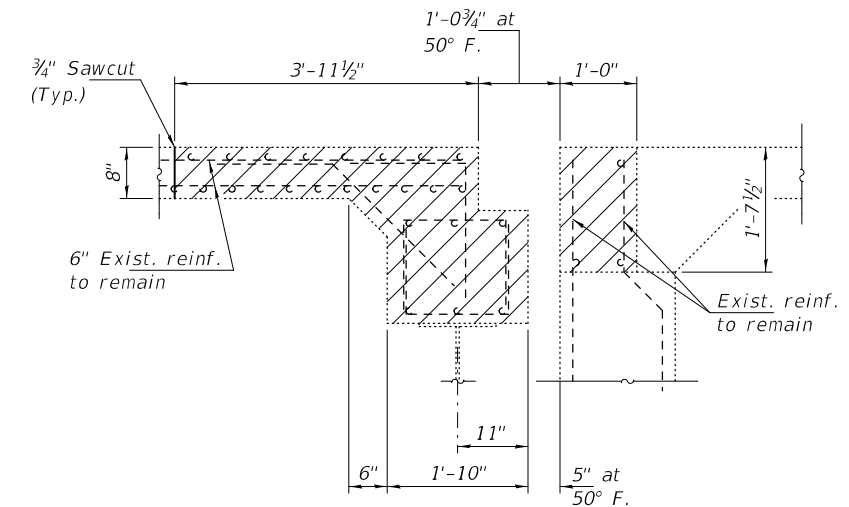
**INSIDE PARAPET ELEVATION**  
(Looking North)



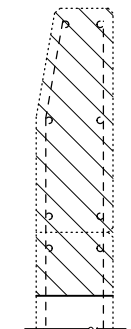
**SECTION HH-HH**



**SECTION THRU PARAPETS**


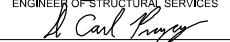


**SECTION G-G**



**SECTION H-H**

DESIGNED - AJR  
CHECKED - JSB  
DRAWN - daburdell  
CHECKED - AJR JSB

EXAMINED  
PASSED  
  
  
 ENGINEER OF STRUCTURAL SERVICES  
 ENGINEER OF BRIDGES AND STRUCTURES

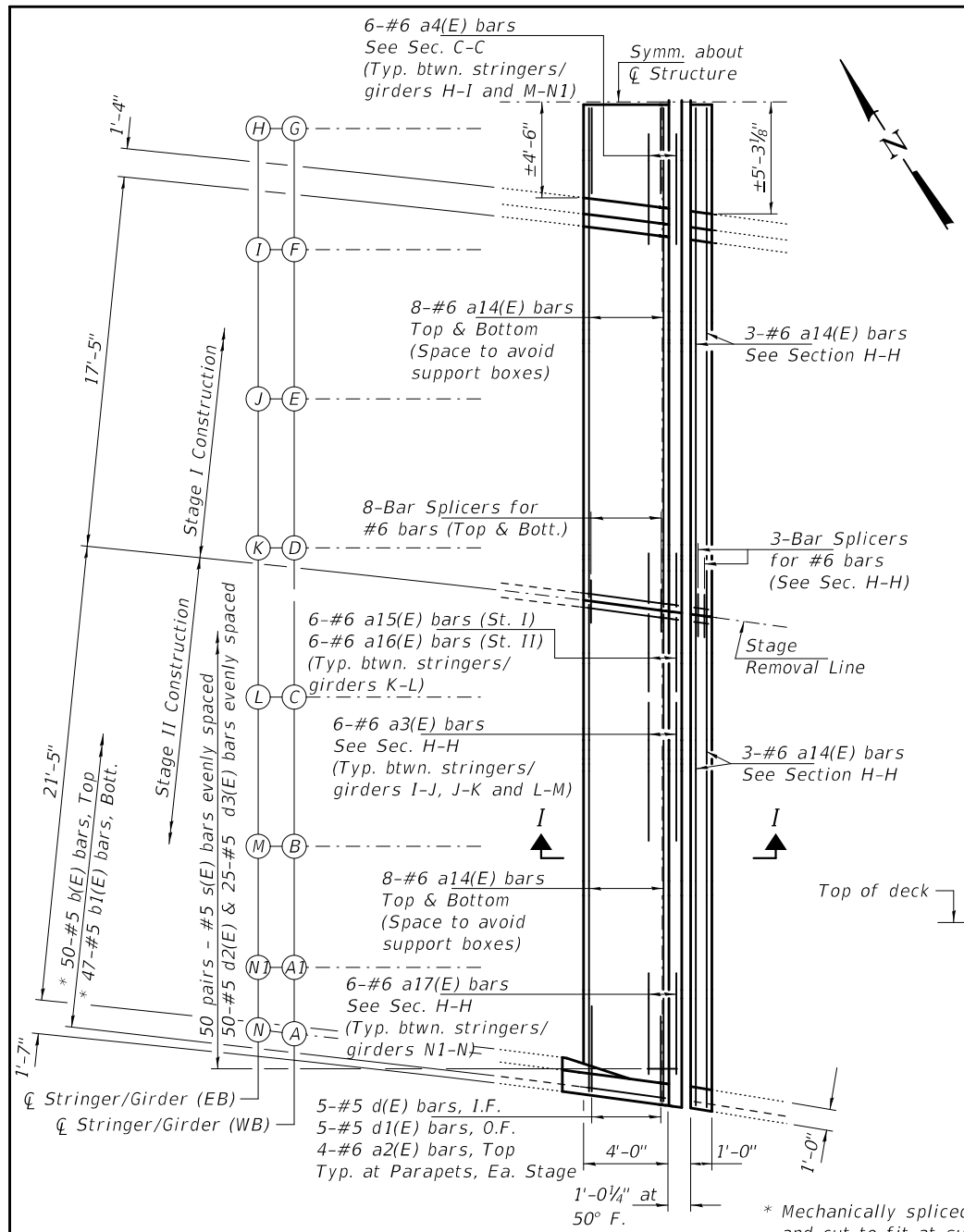
DATE - JANUARY 31, 2020  
 REVISED -  
 REVISED -

**STATE OF ILLINOIS**  
**DEPARTMENT OF TRANSPORTATION**

**JOINT REMOVAL - EAST ABUTMENT**  
**SN 090-0114**

SHEET NO. 7 OF 23 SHEETS

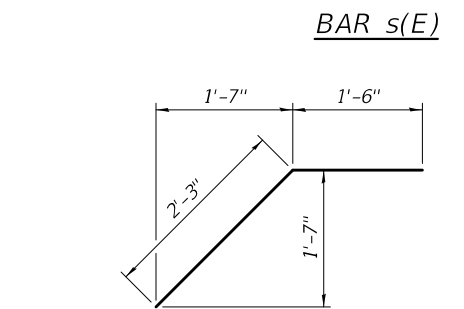
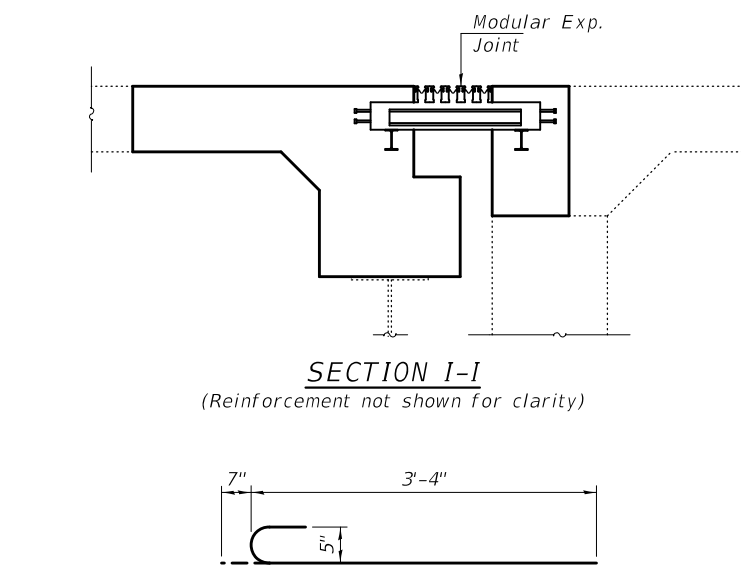
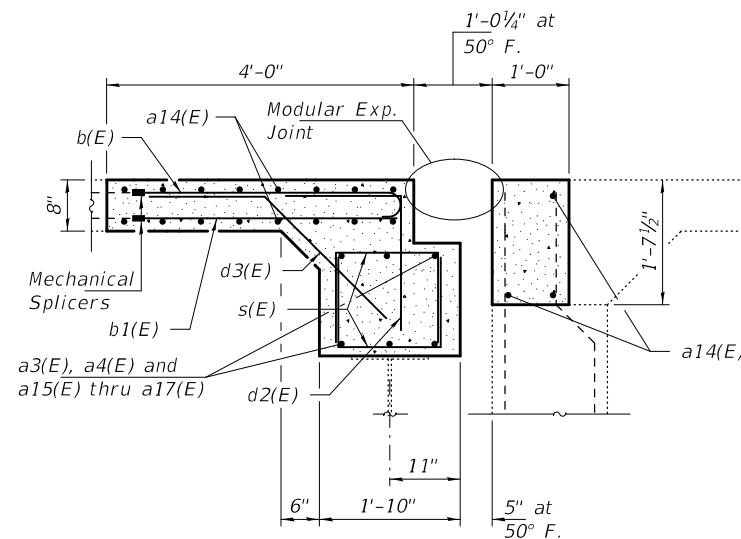
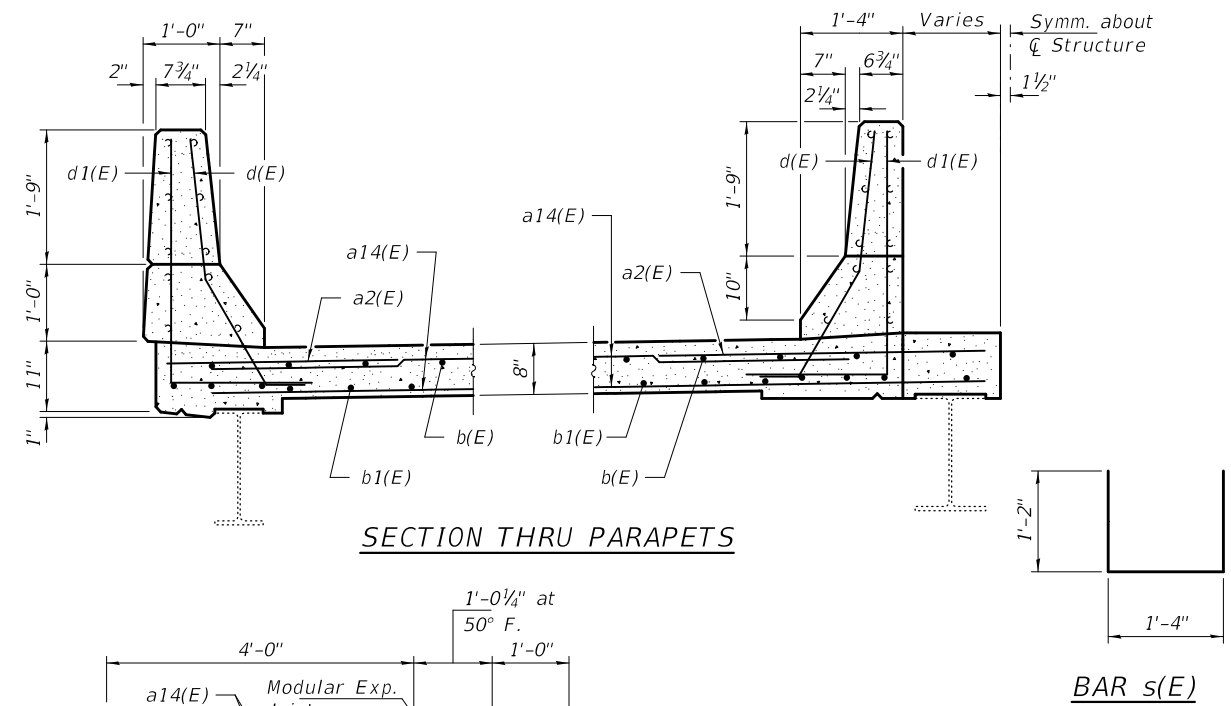
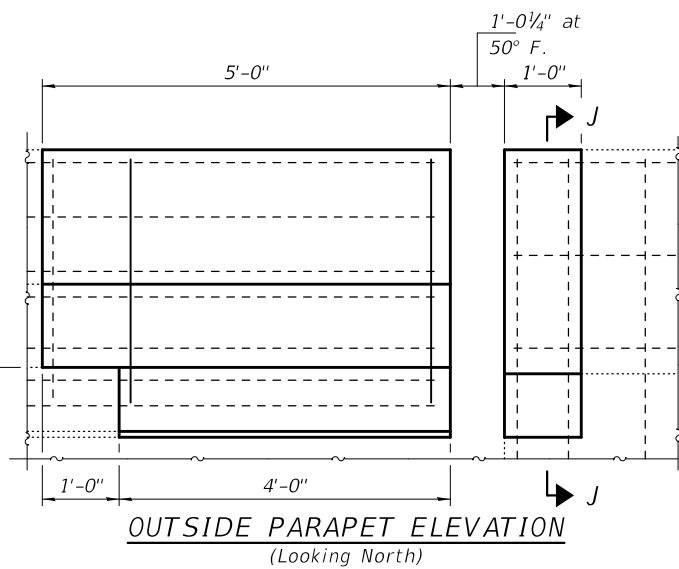
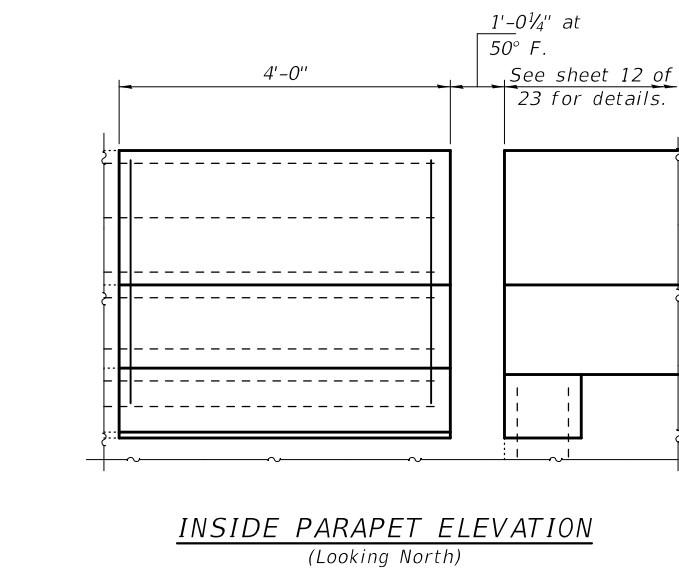
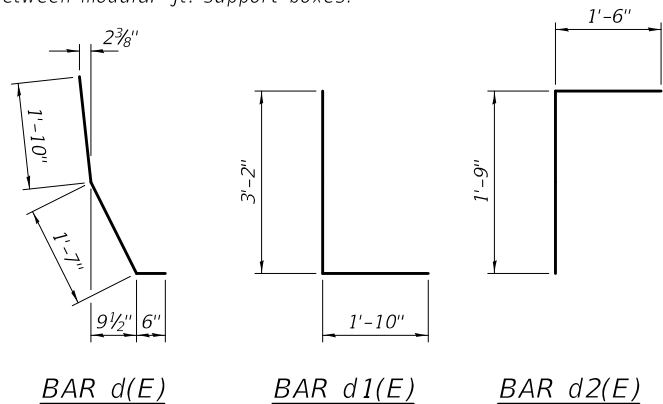
F.A.P. RTE.	SECTION	COUNTY	TOTAL SHEETS	SHEET NO.
693	(12B)BR,BDR,BJR	PEORIA	63	29
CONTRACT NO. 68E79				
ILLINOIS FED. AID PROJECT				



**CONCRETE REPLACEMENT DETAILS**

(East Abutment - E.B. shown,  
W.B. typ. by mirroring)

Note:  
Place d2(E) bars between modular jt. support boxes.



**BILL OF MATERIAL - E. ABUT.**

Bar	No.	Size	Length	Shape
a2(E)	16	#6	4'-0"	—
a3(E)	36	#6	6'-8"	—
a4(E)	24	#6	5'-4"	—
a14(E)	76	#6	22'-10"	—
a15(E)	12	#6	2'-6"	—
a16(E)	12	#6	4'-0"	—
a17(E)	12	#6	4'-9"	—
b(E)	100	#5	3'-11"	┌
b1(E)	94	#5	3'-4"	—
d(E)	20	#5	3'-11"	└
d1(E)	20	#5	5'-0"	L
d2(E)	50	#5	3'-3"	┌
d3(E)	100	#5	3'-9"	└
s(E)	200	#5	3'-8"	┌
Concrete Removal			Cu. Yd.	28.2
Concrete Superstructure			Cu. Yd.	28.3
Bar Splicers			Each	38
Mechanical Splicers			Each	194
Protective Coat			Sq. Yd.	52
Modular Expansion Joint, 9"			Foot	93
Reinforcement Bars, Epoxy Coated			Pound	5700

Placement of reinforcement within the joint block out needs to be coordinated with the joint manufacturer.

DESIGNED - AJR  
CHECKED - JSB  
DRAWN - daburdell  
CHECKED - AJR JSB

EXAMINED  
PASSED  
ENGINEER OF STRUCTURAL SERVICES  
ENGINEER OF BRIDGES AND STRUCTURES

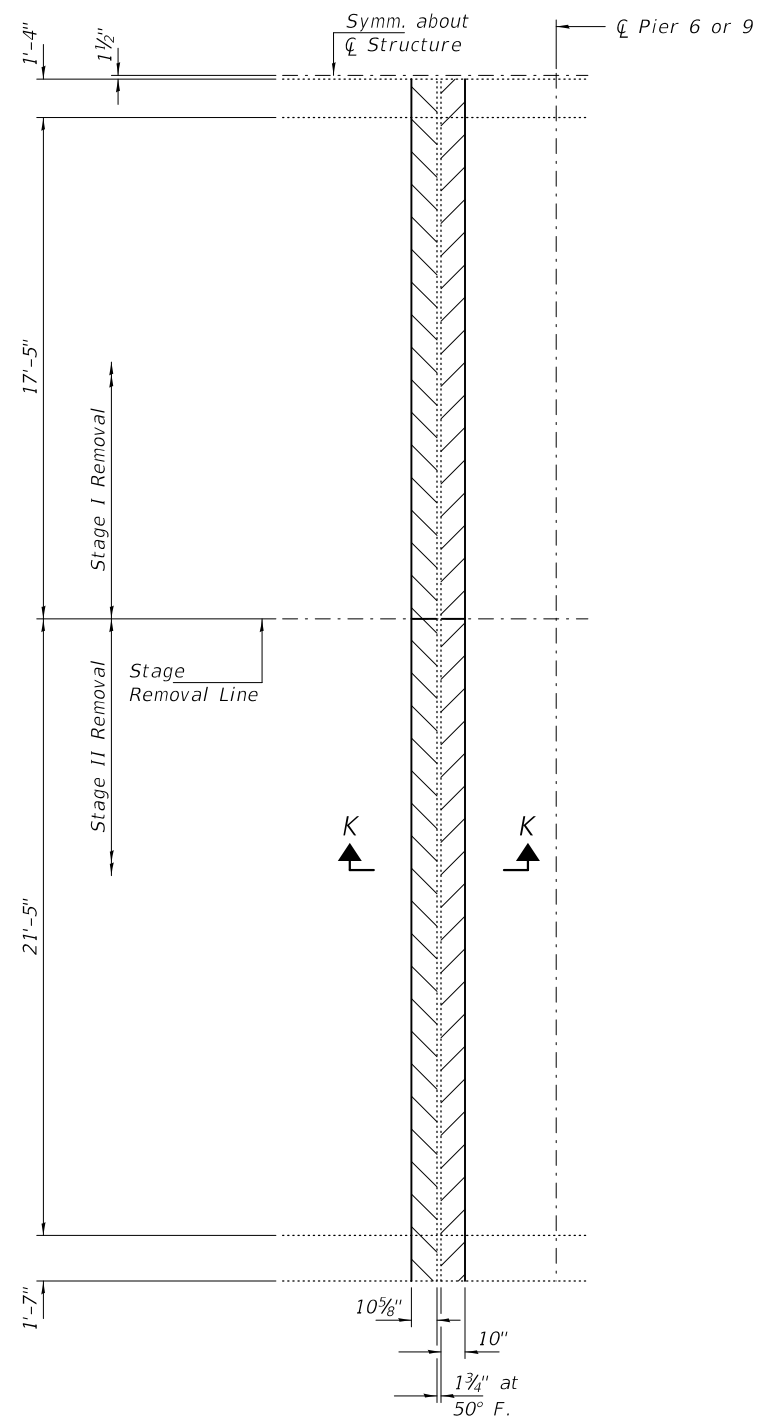
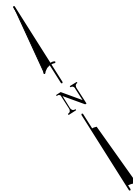
DATE - JANUARY 31, 2020  
REVISED -  
REVISED -

STATE OF ILLINOIS  
DEPARTMENT OF TRANSPORTATION

JOINT REPLACEMENT - EAST ABUTMENT  
SN 090-0114

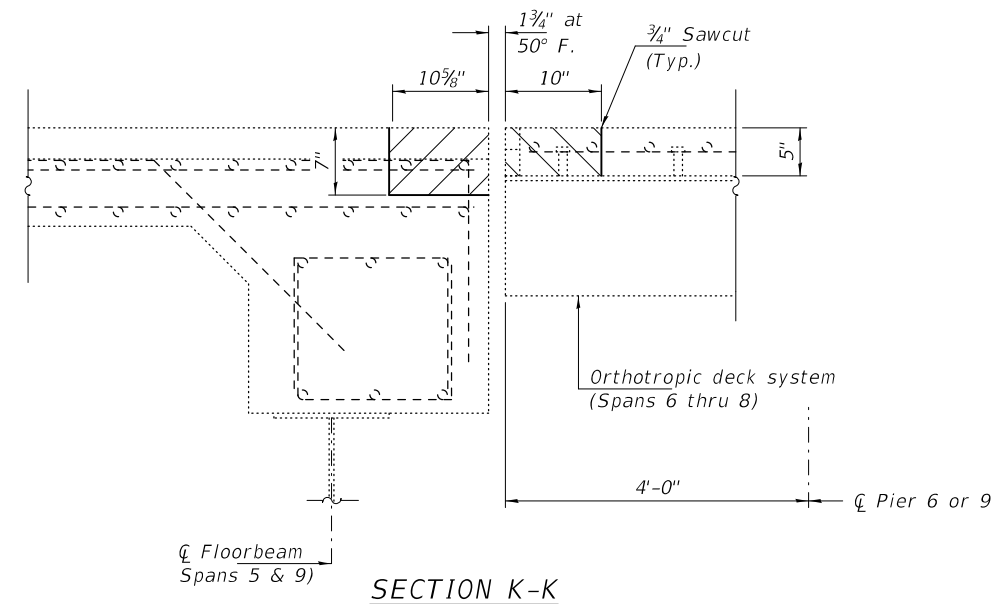
SHEET NO. 8 OF 23 SHEETS

F.A.P. RTE.	SECTION	COUNTY	TOTAL SHEETS	SHEET NO.
693	(12B)BR,BDR,BJR	PEORIA	63	30
				CONTRACT NO. 68E79
ILLINOIS FED. AID PROJECT				

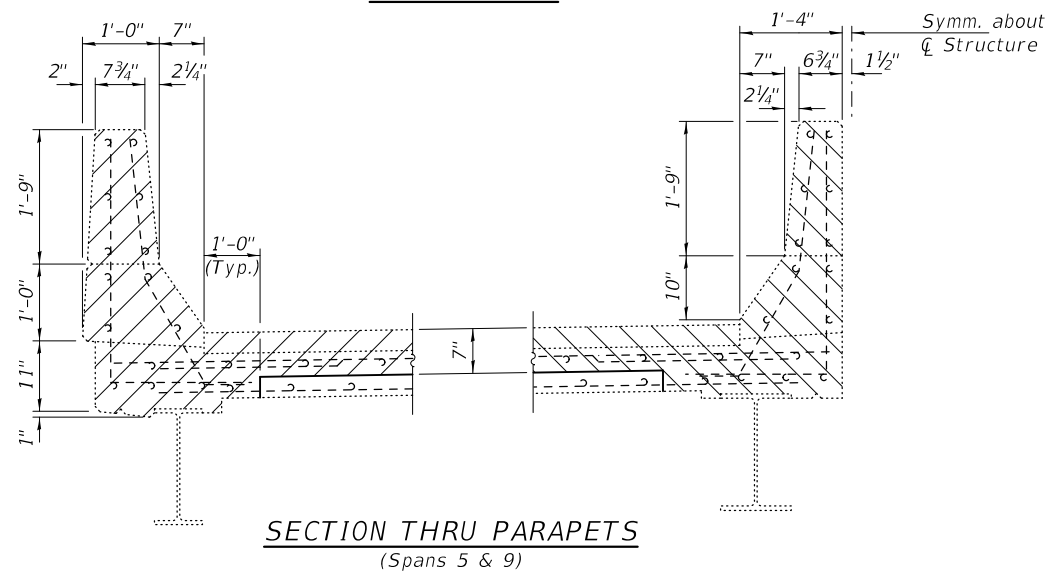


**CONCRETE REMOVAL DETAILS**  
 (Pier 6 - E.B. shown, W.B. typ. by mirroring.)  
 (Pier 9 typ. by rotation.)

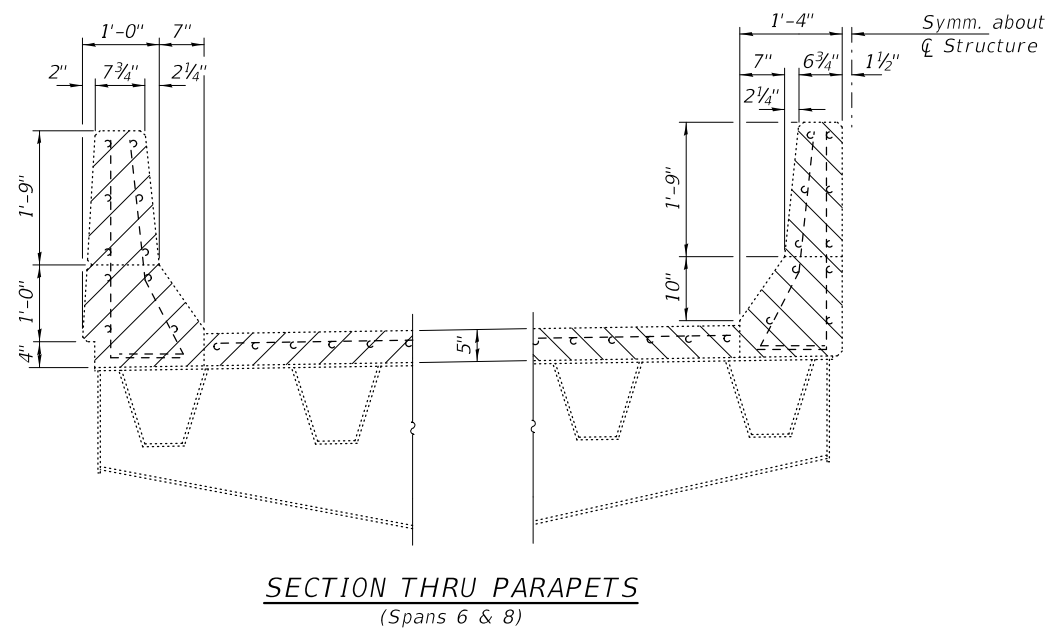
Note:  
 Hatched areas indicate  
 Concrete Removal.



**SECTION K-K**



**SECTION THRU PARAPETS**  
 (Spans 5 & 9)



**SECTION THRU PARAPETS**  
 (Spans 6 & 8)

DESIGNED - AJR  
 CHECKED - JSB  
 DRAWN - daburdell  
 CHECKED - AJR JSB

EXAMINED  
 PASSED  
*Timothy A. Daburdell*  
 ENGINEER OF STRUCTURAL SERVICES  
*Carl R. Poyner*  
 ENGINEER OF BRIDGES AND STRUCTURES

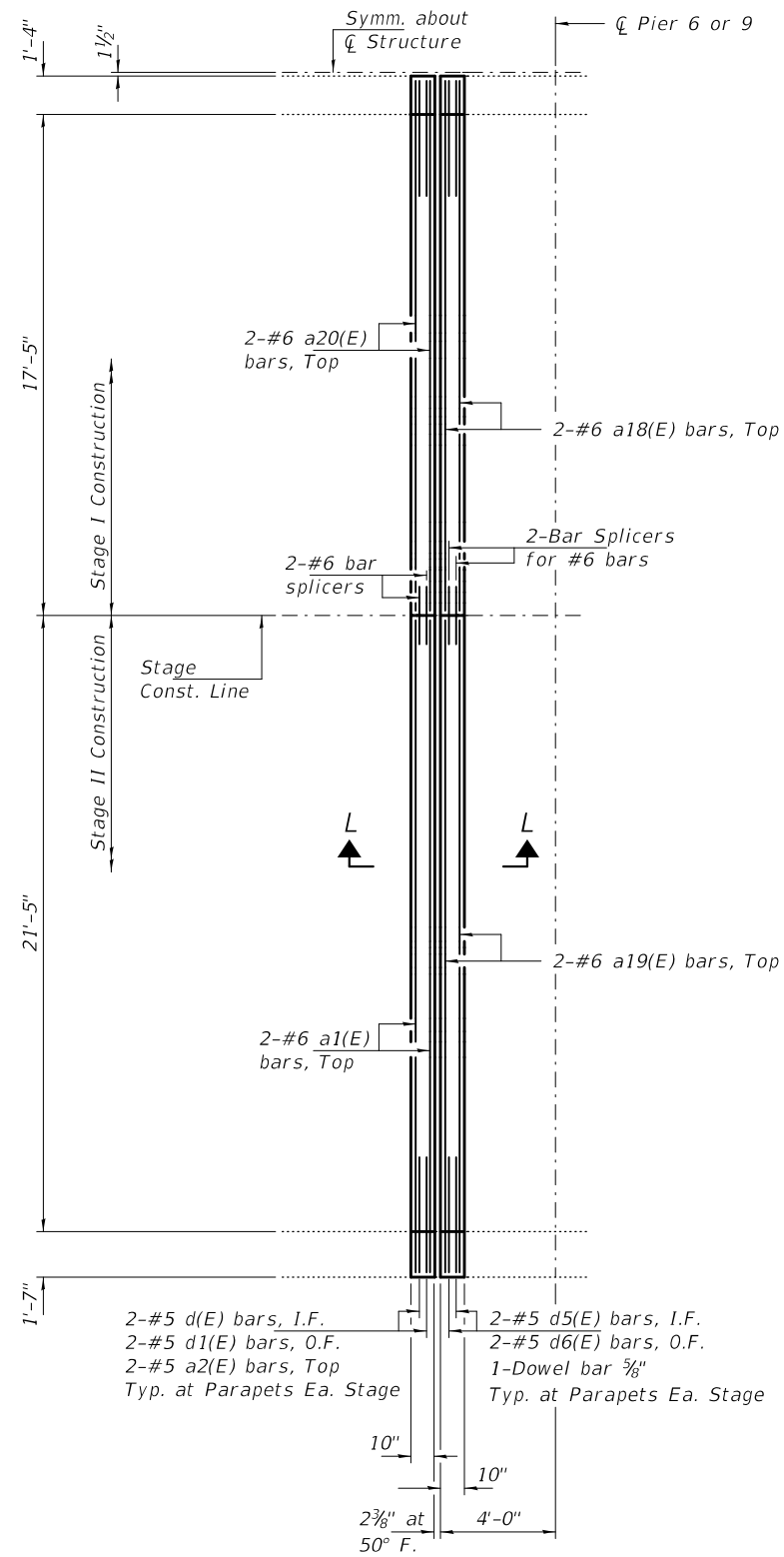
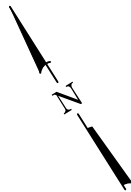
DATE - JANUARY 31, 2020  
 REVISED -  
 REVISED -

STATE OF ILLINOIS  
 DEPARTMENT OF TRANSPORTATION

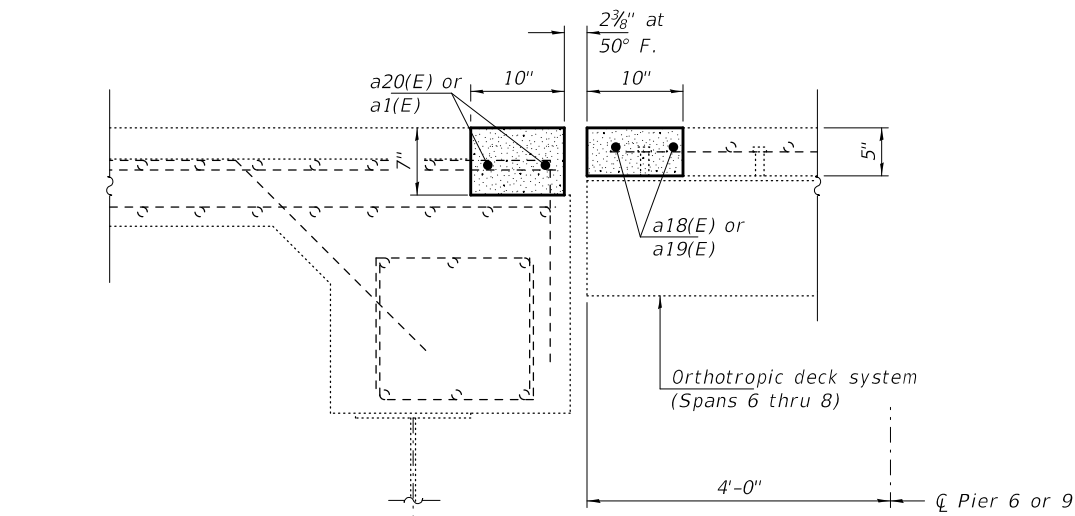
JOINT REMOVAL - PIERS 6 & 9  
 SN 090-0114

SHEET NO. 9 OF 23 SHEETS

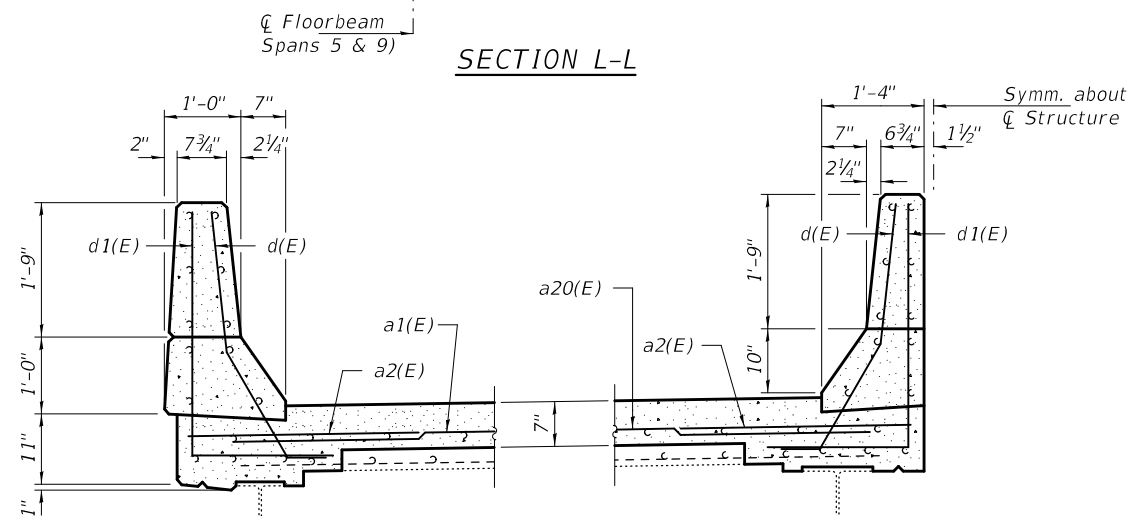
F.A.P. RTE.	SECTION	COUNTY	TOTAL SHEETS	SHEET NO.
693	(12B)BR,BDR,BJR	PEORIA	63	31
CONTRACT NO. 68E79				
ILLINOIS FED. AID PROJECT				



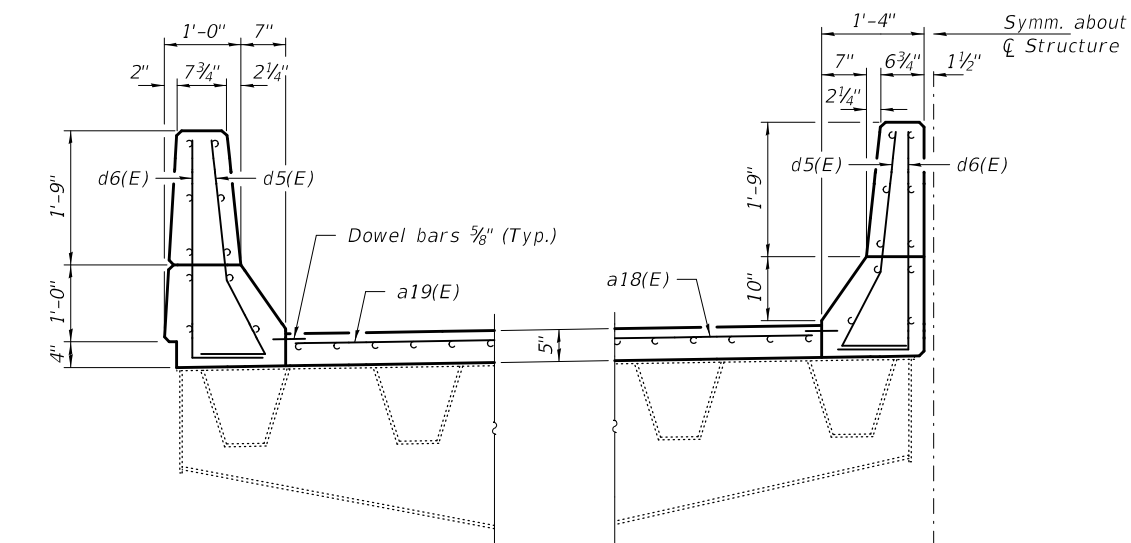
**CONCRETE REPLACEMENT DETAILS**  
 (Pier 6 - E.B. shown, W.B. typ. by mirroring.)  
 (Pier 9 typ. by rotation.)



**SECTION L-L**

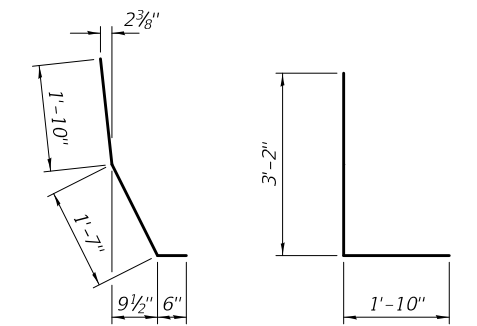


**SECTION THRU PARAPETS**  
 (Spans 5 & 9)

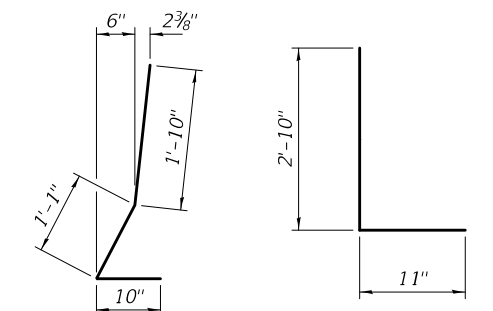


**SECTION THRU PARAPETS**  
 (Spans 6 & 8)

Notes:  
 Remove approach span deck concrete to a depth that permits complete removal of existing joint angle with studs.  
 If strip seal studs interfere with orthotropic deck studs remove and replace deck studs between strip seal studs.



**BAR d(E)**      **BAR d1(E)**



**BAR d5(E)**      **BAR d6(E)**

**BILL OF MATERIAL - PIERS 6 & 9**

Bar	No.	Size	Length	Shape
a1(E)	8	#6	22'-8"	—
a2(E)	16	#6	4'-0"	—
a20(E)	8	#6	18'-5"	—
a18(E)	8	#6	17'-1"	—
a19(E)	8	#6	21'-1"	—
d(E)	16	#5	3'-11"	↘
d1(E)	16	#5	5'-0"	L
d5(E)	16	#5	3'-9"	↘
d6(E)	16	#5	3'-9"	L
Concrete Removal		Cu. Yd.	6.8	
Concrete Superstructure		Cu. Yd.	6.4	
Bar Splicers		Each	16	
Protective Coat		Sq. Yd.	18	
Reinforcement Bars, Epoxy Coated		Pound	1320	
Dowel Bars 3/8"		Each	8	

DESIGNED - AJR  
 CHECKED - JSB  
 DRAWN - daburdell  
 CHECKED - AJR JSB

EXAMINED  
 PASSED  
 ENGINEER OF STRUCTURAL SERVICES  
 ENGINEER OF BRIDGES AND STRUCTURES

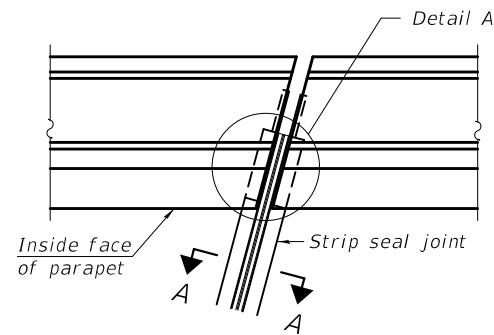
DATE - JANUARY 31, 2020  
 REVISED -  
 REVISED -

STATE OF ILLINOIS  
 DEPARTMENT OF TRANSPORTATION

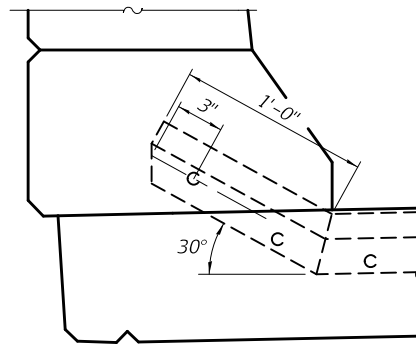
JOINT REPLACEMENT - PIERS 6 & 9  
 SN 090-0114

SHEET NO. 10 OF 23 SHEETS

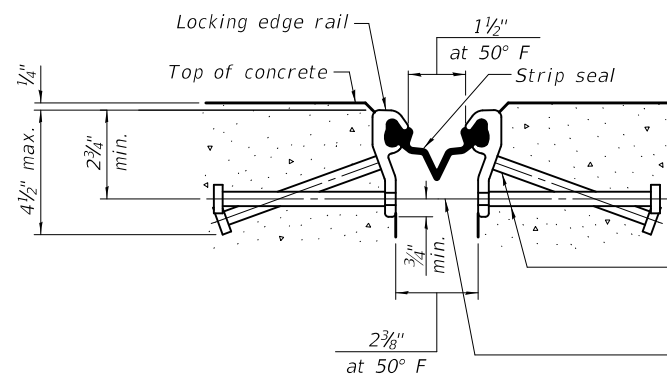
F.A.P. RTE. SECTION COUNTY TOTAL SHEETS SHEET NO.  
 693 (12B)BR,BDR,BJR PEORIA 63 32  
 CONTRACT NO. 68E79  
 ILLINOIS FED. AID PROJECT



FOR SKEWS  $\leq 30^\circ$   
**PLAN AT PARAPET**



**DETAIL A**



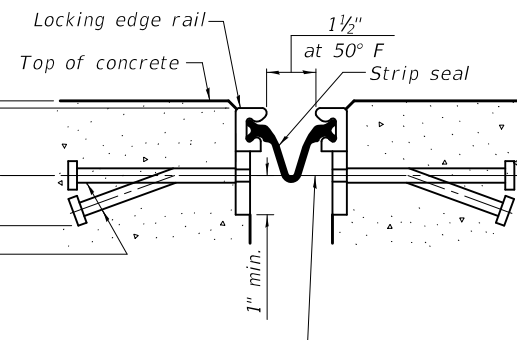
**SHOWING ROLLED RAIL JOINT**

\*  $\frac{5}{8}$ "  $\phi$  x 6" studs @ 6" cts. (alternate angled/bent studs with horizontal studs)

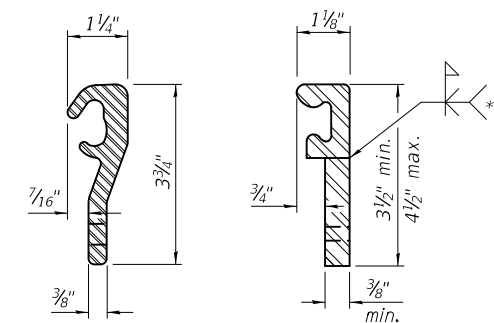
$\frac{3}{8}$ "  $\phi$  threaded rods in  $\frac{7}{16}$ "  $\phi$  holes at  $\pm 4$ "-0" cts. for holding the proper joint opening based on the temperature during the deck pour. Place to miss studs. All rods shall be burned, or sawed off flush with the plates after concrete is set.

**SECTION A-A**

\* Granular or solid flux filled headed studs conforming to Article 1006.32 of the Std. Specs., automatically end welded.



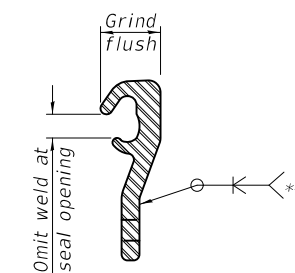
**SHOWING WELDED RAIL JOINT**



**ROLLED (EXTRUDED) RAIL**      **WELDED RAIL**

**LOCKING EDGE RAILS**

\*\* Back gouge not required if complete joint penetration is verified by mock-up.



**LOCKING EDGE RAIL SPLICE**

The inside of the locking edge rail groove shall be free of weld residue. Rolled rail shown, welded rail similar.

**BILL OF MATERIAL**

Item	Unit	Total
Preformed Joint Strip Seal	Foot	164

DESIGNED - AJR  
 CHECKED - JSB  
 DRAWN - daburdell  
 CHECKED - AJR JSB

EXAMINED  
 PASSED  
*Timothy A. Daburdell*  
 ENGINEER OF STRUCTURAL SERVICES  
*Carl R. Rieger*  
 ENGINEER OF BRIDGES AND STRUCTURES

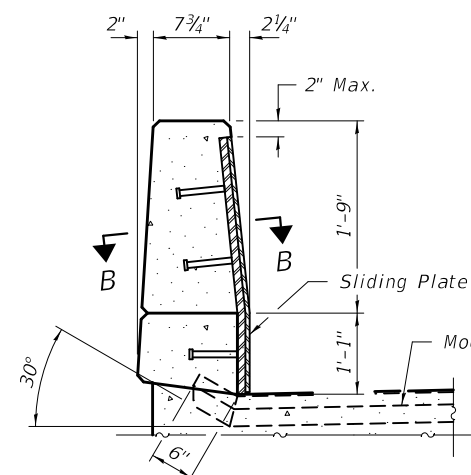
DATE - JANUARY 31, 2020  
 REVISED -  
 REVISED -

**STATE OF ILLINOIS**  
**DEPARTMENT OF TRANSPORTATION**

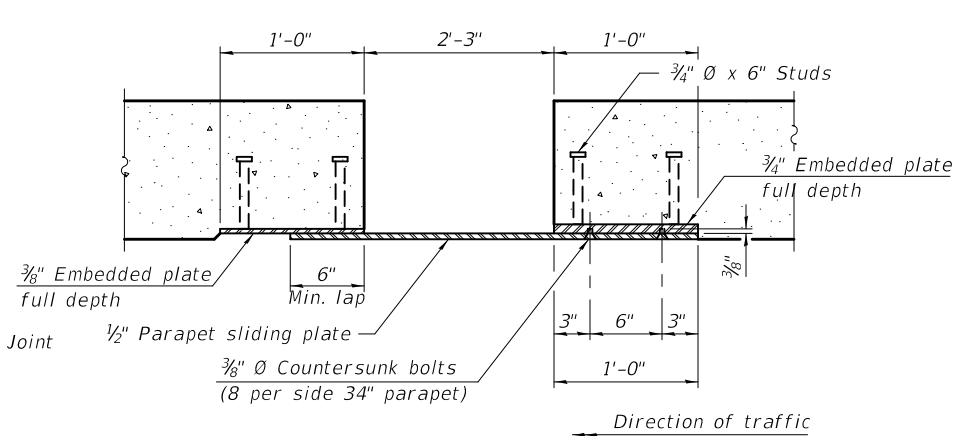
**PREFORMED JOINT STRIP SEAL - PIERS 6 & 9**  
**SN 090-0114**

SHEET NO. 11 OF 23 SHEETS

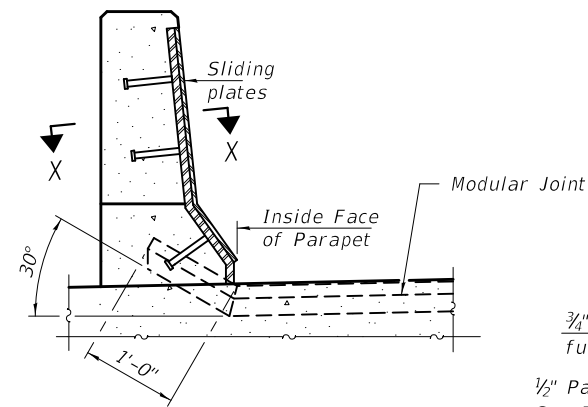
F.A.P. RTE.	SECTION	COUNTY	TOTAL SHEETS	SHEET NO.
693	(12B)BR,BDR,BJR	PEORIA	63	33
ILLINOIS			CONTRACT NO. 68E79	
FED. AID PROJECT				



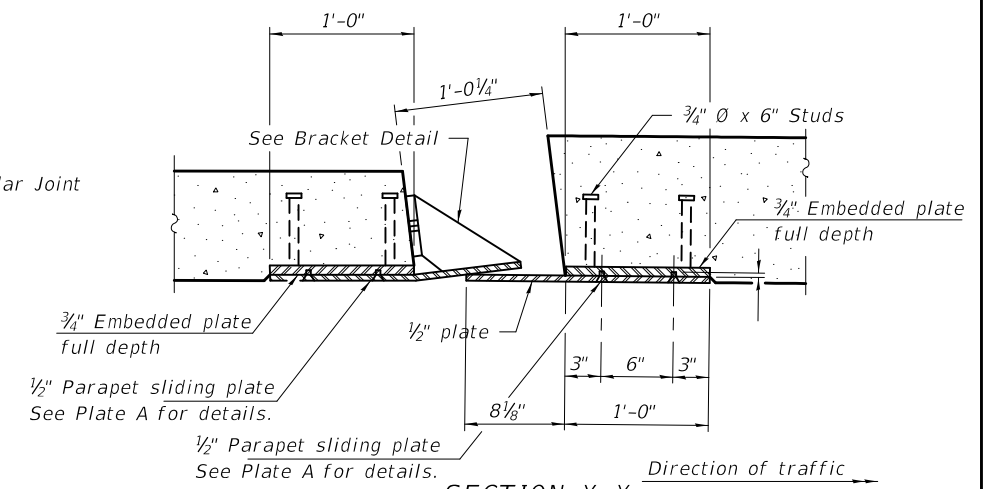
**ELEVATION AT PARAPET**  
(West Abutment)



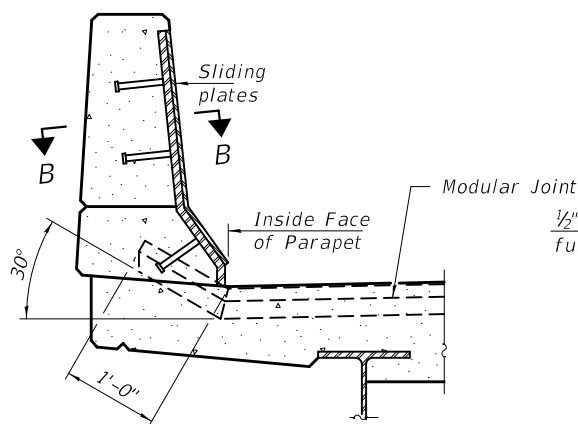
**SECTION B-B**  
(West Abutment)



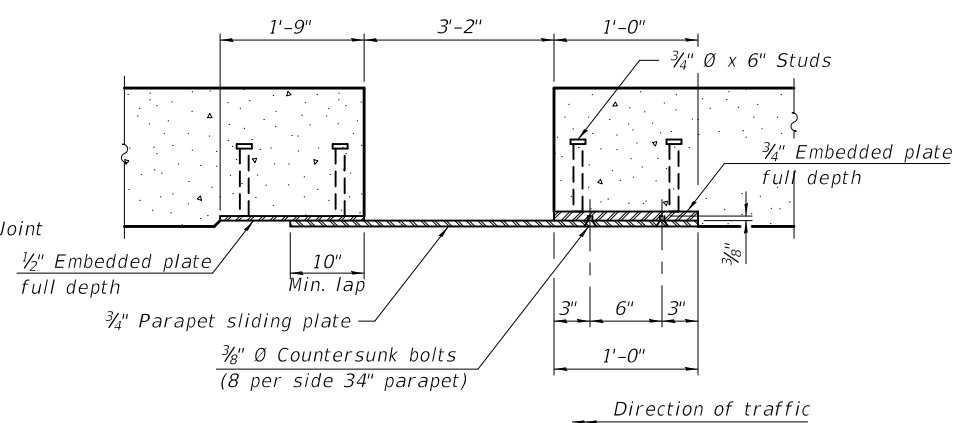
**ELEVATION AT MEDIAN**  
(East Abutment)



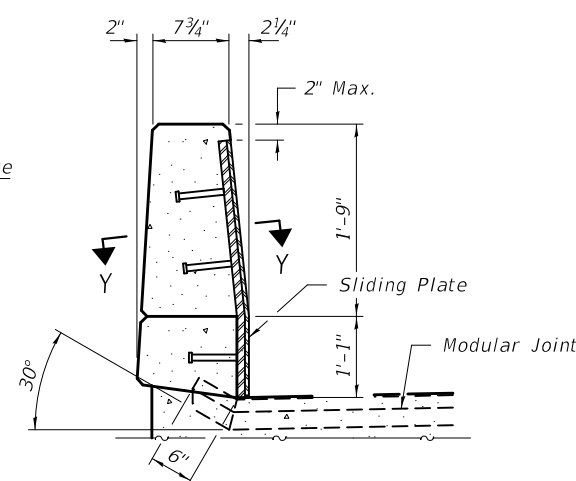
**SECTION X-X**  
(East Abutment)  
(E.B. Parapet shown, W.B. similar by mirroring)



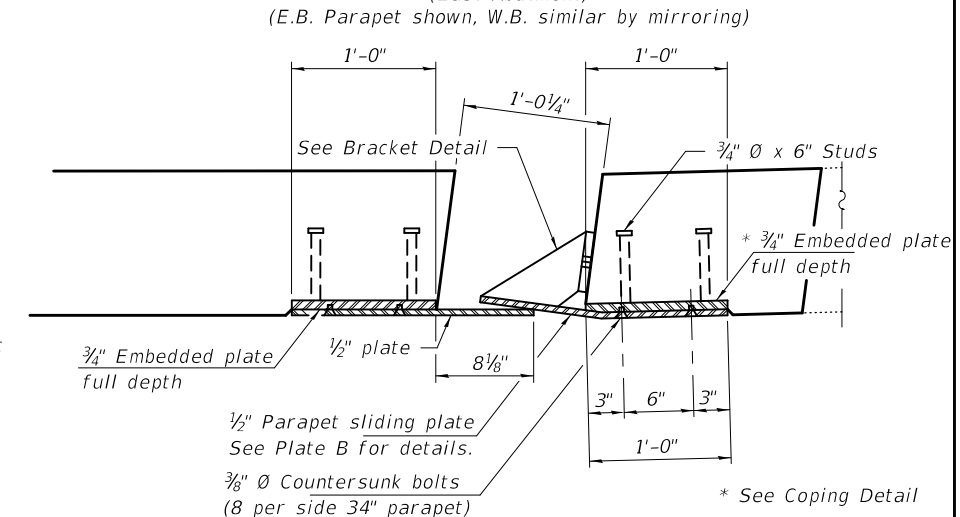
**ELEVATION AT MEDIAN**  
(West Abutment & Pier 5)



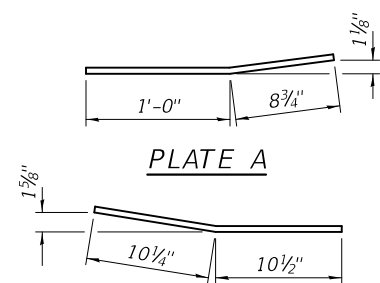
**SECTION B-B**  
(Typ. all locations at Pier 5)



**ELEVATION AT PARAPET**  
(East Abutment)

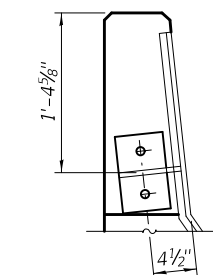


**SECTION Y-Y**  
(East Abutment)  
(W.B. Parapet shown, E.B. similar by mirroring)

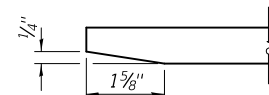


**PLATE A**

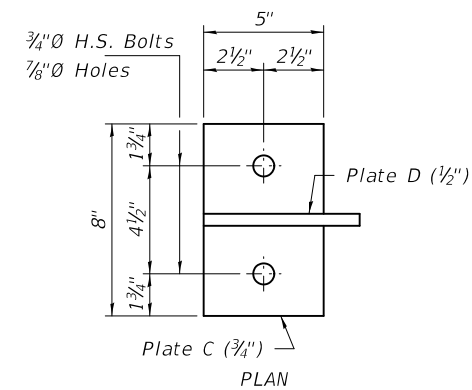
**PLATE B**



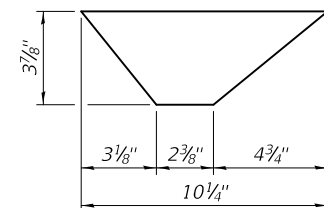
**BRACKET PLACEMENT**



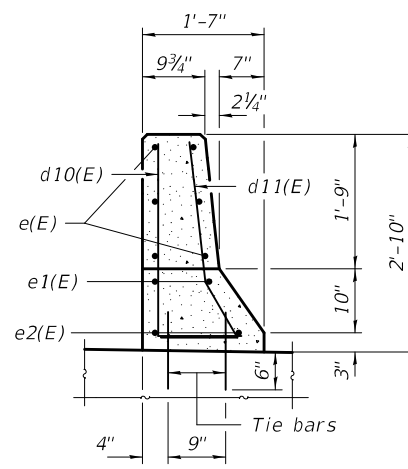
**COPING DETAIL**



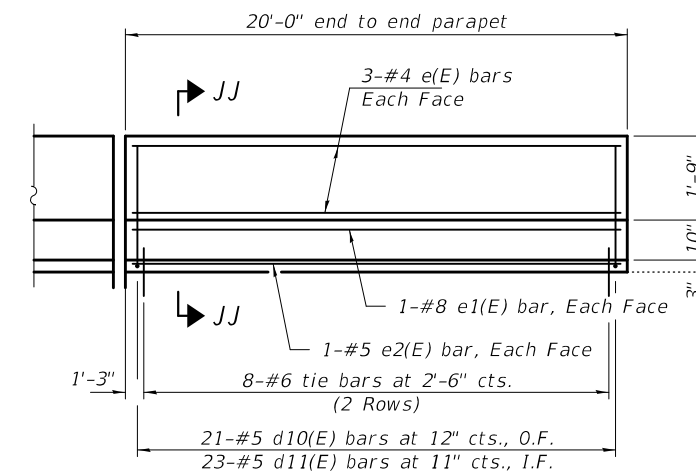
**BRACKET DETAILS**



**PLATE D**

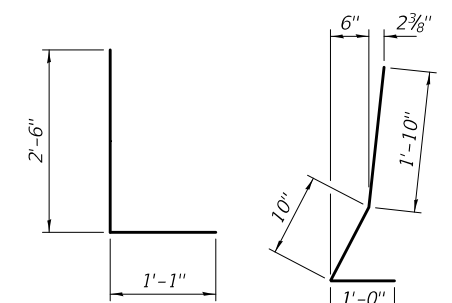


**SECTION JJ-JJ**



**INSIDE ELEVATION OF APPROACH MEDIAN BARRIER**  
(East Abutment)

Notes:  
The cost of the tie bars shall be included with Concrete Superstructure.  
Removal of Temporary Concrete Barrier shall be included with Concrete Superstructure.



**BAR d10(E) BAR d11(E)**  
**BILL OF MATERIAL - 2 PARAPETS**

Bar	No.	Size	Length	Shape
d10(E)	16	#5	3'-7"	L
d11(E)	16	#5	4'-8"	L
e(E)	12	#4	19'-8"	—
e1(E)	4	#8	19'-8"	—
e2(E)	4	#5	19'-8"	—
Concrete Superstructure			Cu. Yd.	4.5
Reinforcement Bars, Epoxy Coated			Pound	590
Protective Coat			Sq. Yd.	17

DESIGNED - AJR  
CHECKED - JSB  
DRAWN - daburdell  
CHECKED - AJR JSB

EXAMINED  
PASSED  
ENGINEER OF STRUCTURAL SERVICES  
ENGINEER OF BRIDGES AND STRUCTURES

DATE - JANUARY 31, 2020  
REVISED -  
REVISED -

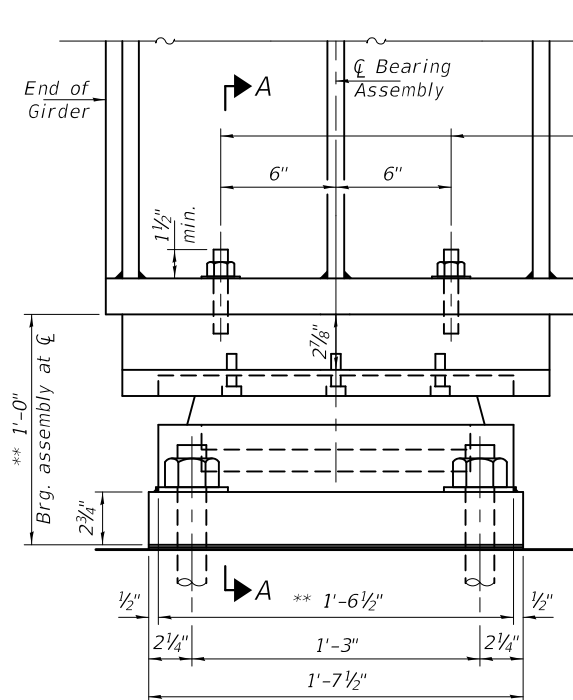
STATE OF ILLINOIS  
DEPARTMENT OF TRANSPORTATION

SLIDING PLATE DETAILS AT MODULAR JOINTS  
SN 090-0114

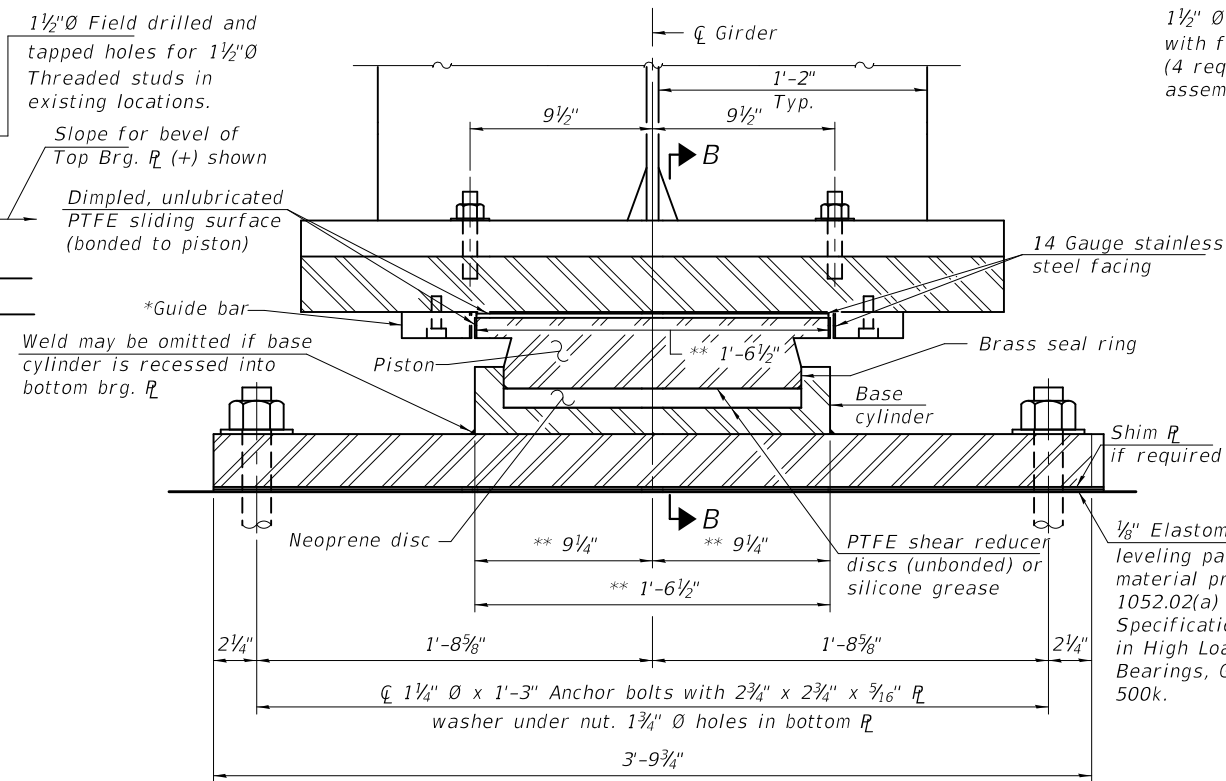
SHEET NO. 12 OF 23 SHEETS

F.A.P. RTE. SECTION COUNTY TOTAL SHEETS SHEET NO.  
693 (12B)BR,BDR,BJR PEORIA 63 34  
CONTRACT NO. 68E79  
ILLINOIS FED. AID PROJECT



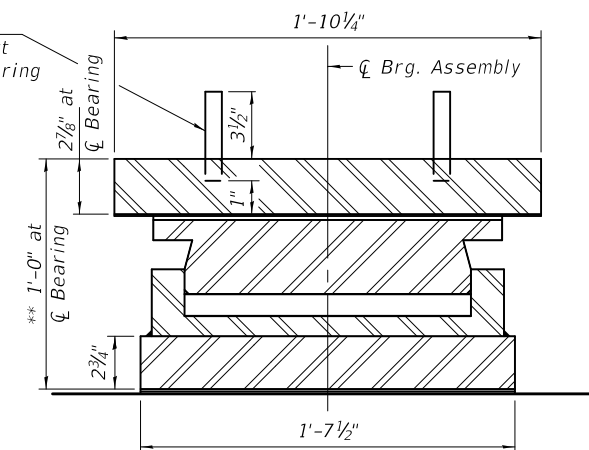


**ELEVATION**



**SECTION A-A**

1 1/2" Ø H.S. threaded studs with flat washer and hex nut (4 required) (included in bearing assembly)



**SECTION B-B**

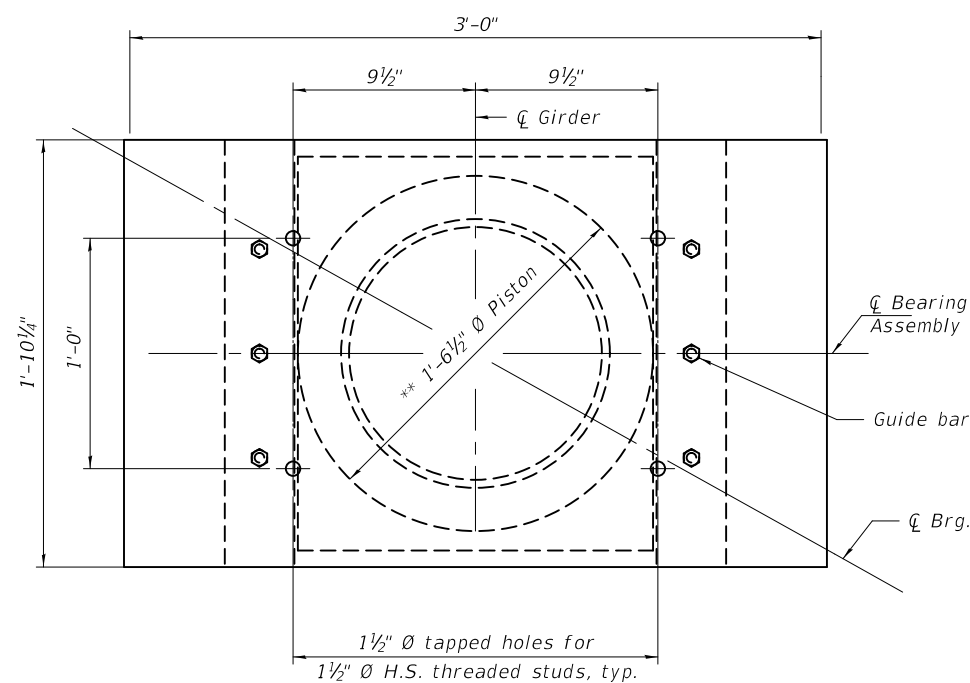
(Guide bar and girder omitted for clarity)

**Notes:**  
 Anchor bolts shall be ASTM F1554 all-thread (or an Engineer-approved alternate material) of the grade(s) and diameter(s) specified. The corresponding specified grade of AASHTO M314 anchor bolts may be used in lieu of ASTM F1554.  
 Drilled and set anchor bolts shall be installed according to Article 521.06 of the Standard Specifications.  
 The structural steel plates of the Bearing Assembly shall conform to the requirements of AASHTO M 270, Grade 50.  
 Two 1/8" adjusting shims shall be provided for each bearing in addition to all other plates or shims and placed as shown on bearing details.  
 Bearing dimensions and details shown are for a pot type HLMR bearing. Disc type HLMR bearing dimensions and details will vary.  
 Bearing Assembly height is estimated based on manufacturer data. Actual bearing height may differ from contract plans. The Contractor shall be responsible verifying bearing heights and adjusting concrete pedestal elevations, if required.  
 Modifications to the Bearing plates at abutments or piers shall consider the location of the backwall or concrete pedestal dimensions and required expansion length if exceeding the end of the girder.

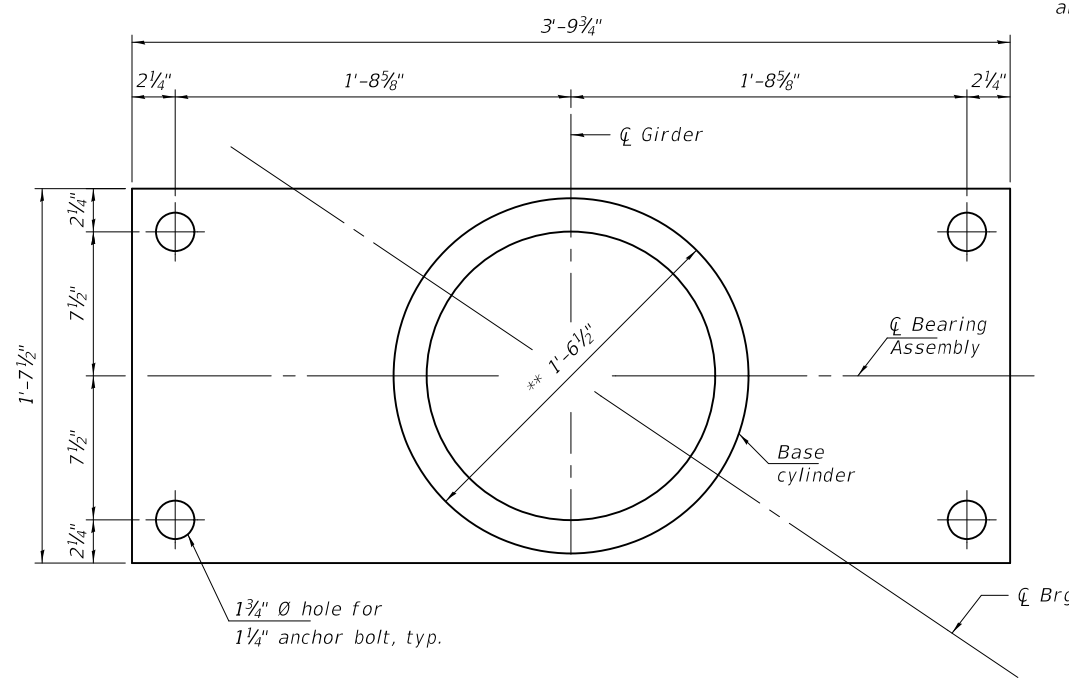
\*\* Dimensions may vary depending on Manufacturer's design.

\* As alternates to the bolted connection shown, the guide bars may be connected to the top bearing plate by groove welds or the guide bars and top bearing plate may be fabricated as a single piece. If bolted connection is used, maintain a minimum clearance of 3" from the centerline of the threaded stud to the bolts in the guide bar.

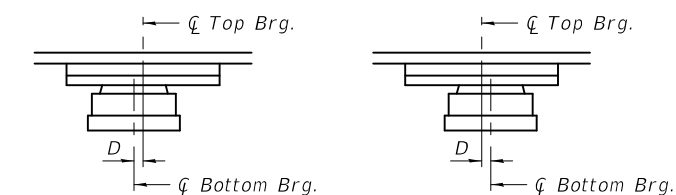
\*\*\* Rotation allowances for fabrication tolerances (0.005 rad) and installation uncertainties (0.005 rad) excluded.



**TOP BEARING P AND PISTON PLAN**



**BOTTOM BEARING P AND BASE CYLINDER PLAN**



**SETTING ANCHOR BOLTS AT EXP. BRG.**  
 D=1/8" per each 100' of expansion for every 15° temp. change from the normal temp. of 50° F.

**DESIGN DATA**

Data	W. Abut.
Service Vertical Design Load (kips)	632
Horizontal Design Load (kips), Hu	127
Design Rotation (rad), θu ***	0.0074
Total Required Movement (in.)	4 7/8
Slope for Bevel of Top Brg. P (%)	+4.69

**BILL OF MATERIAL**

Item	Unit	Total
High Load Multi-Rotational Bearings, Guided Expansion, 650k	Each	4
Anchor Bolts, 1 1/4"	Each	16

DESIGNED - AJR	EXAMINED - <i>Timothy A. Daulton</i>	DATE - JANUARY 31, 2020
CHECKED - JSB	ENGINEER OF STRUCTURAL SERVICES	
DRAWN - Venkat Reddy	PASSED - <i>Carl Berger</i>	REVISD -
CHECKED - AJR JSB	ENGINEER OF BRIDGES AND STRUCTURES	REVISD -

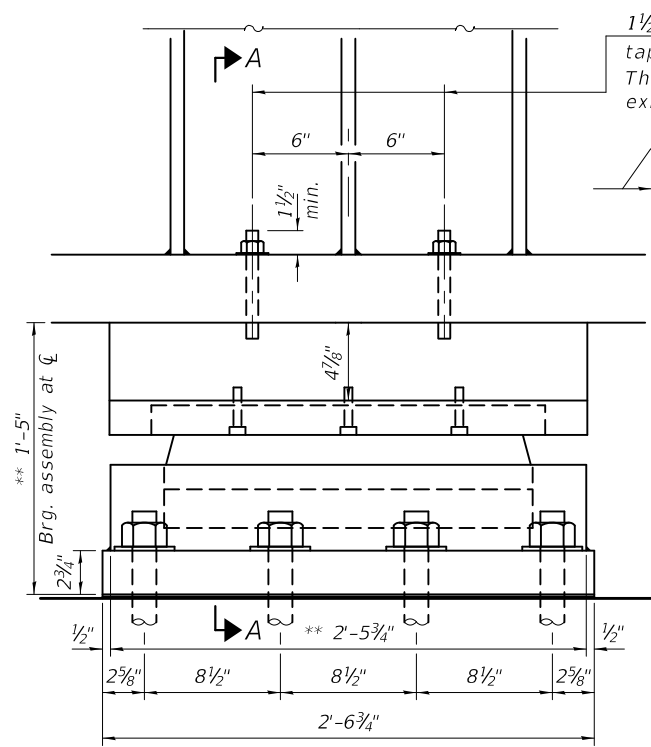
**STATE OF ILLINOIS  
 DEPARTMENT OF TRANSPORTATION**

**WEST ABUTMENT BEARING DETAILS  
 SN 090-0114**

SHEET NO. 13 OF 23 SHEETS

F.A.P. RTE.	SECTION	COUNTY	TOTAL SHEETS	SHEET NO.
693	(12B)BR,BDR,BJR	PEORIA	63	35
CONTRACT NO. 68E79				
ILLINOIS FED. AID PROJECT				

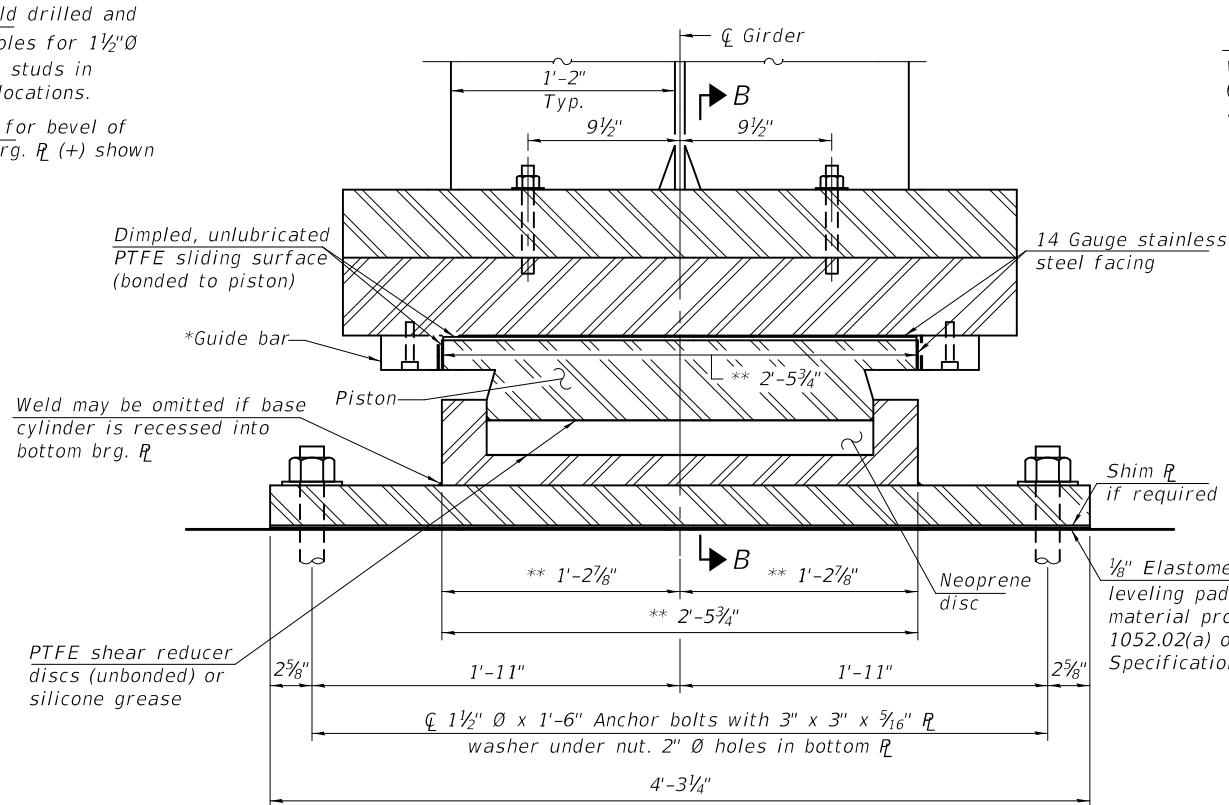




**ELEVATION**

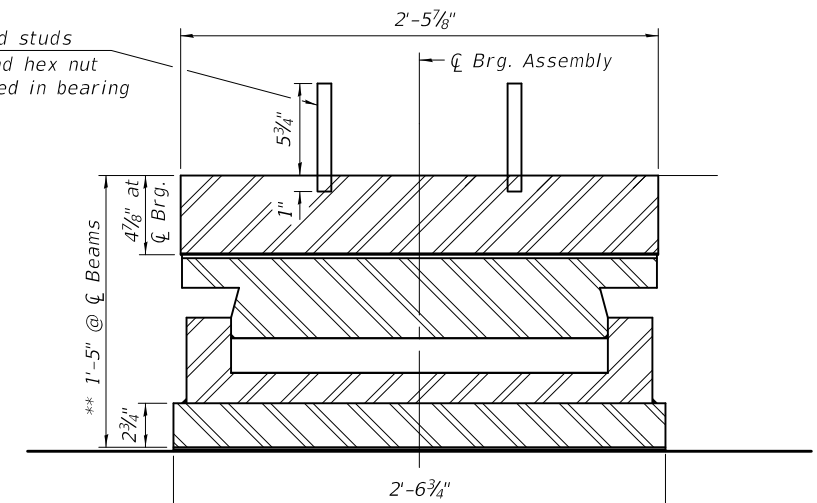
\*\* Dimensions may vary depending on Manufacturer's design.  
 \*\*\* Rotation allowances for fabrication tolerances (0.005 rad) and installation uncertainties (0.005 rad) excluded.

\* As alternates to the bolted connection shown, the guide bars may be connected to the top bearing plate by groove welds or the guide bars and top bearing plate may be fabricated as a single piece. If bolted connection is used, maintain a minimum clearance of 3" from the centerline of the threaded stud to the bolts in the guide bar.



**SECTION A-A**

1 1/2" Ø H.S. threaded studs with flat washer and hex nut (4 required) (included in bearing assembly)



**SECTION B-B**

(Guide bar and girder omitted for clarity)

Notes:

Anchor bolts shall be ASTM F1554 all-thread (or an Engineer-approved alternate material) of the grade(s) and diameter(s) specified. The corresponding specified grade of AASHTO M314 anchor bolts may be used in lieu of ASTM F1554.

Drilled and set anchor bolts shall be installed according to Article 521.06 of the Standard Specifications.

The structural steel plates of the Bearing Assembly shall conform to the requirements of AASHTO M 270, Grade 50.

Two 1/8" adjusting shims shall be provided for each bearing in addition to all other plates or shims and placed as shown on bearing details.

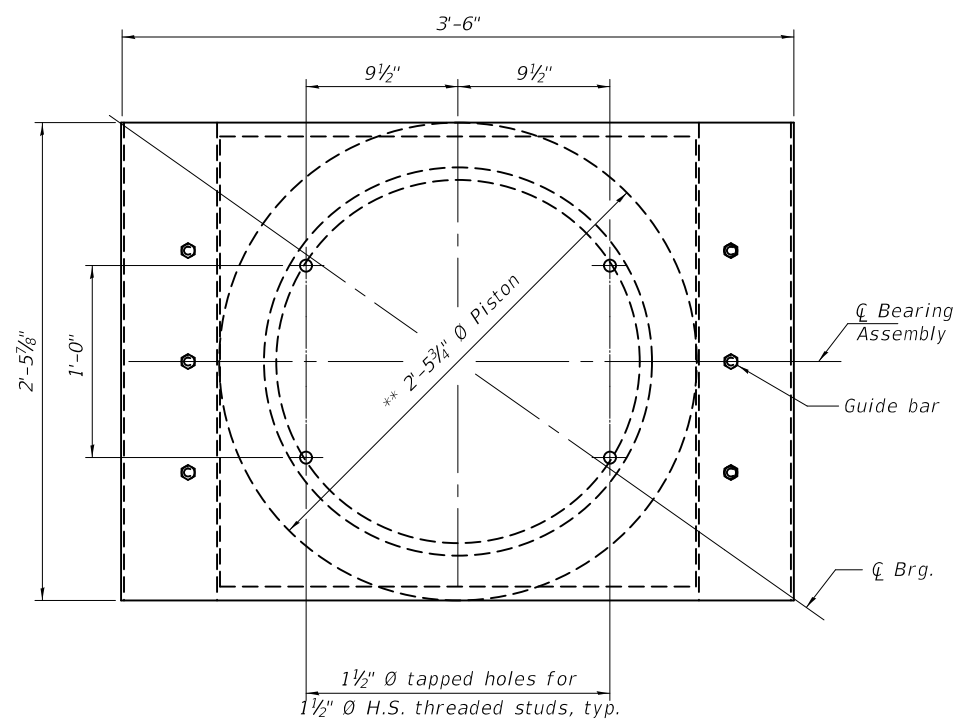
Bearing dimensions and details shown are for a pot type HLMR bearing. Disc type HLMR bearing dimensions and details will vary.

Bearing Assembly height is estimated based on manufacturer data. Actual bearing height may differ from contract plans. The Contractor shall be responsible verifying bearing heights and adjusting concrete pedestal elevations, if required.

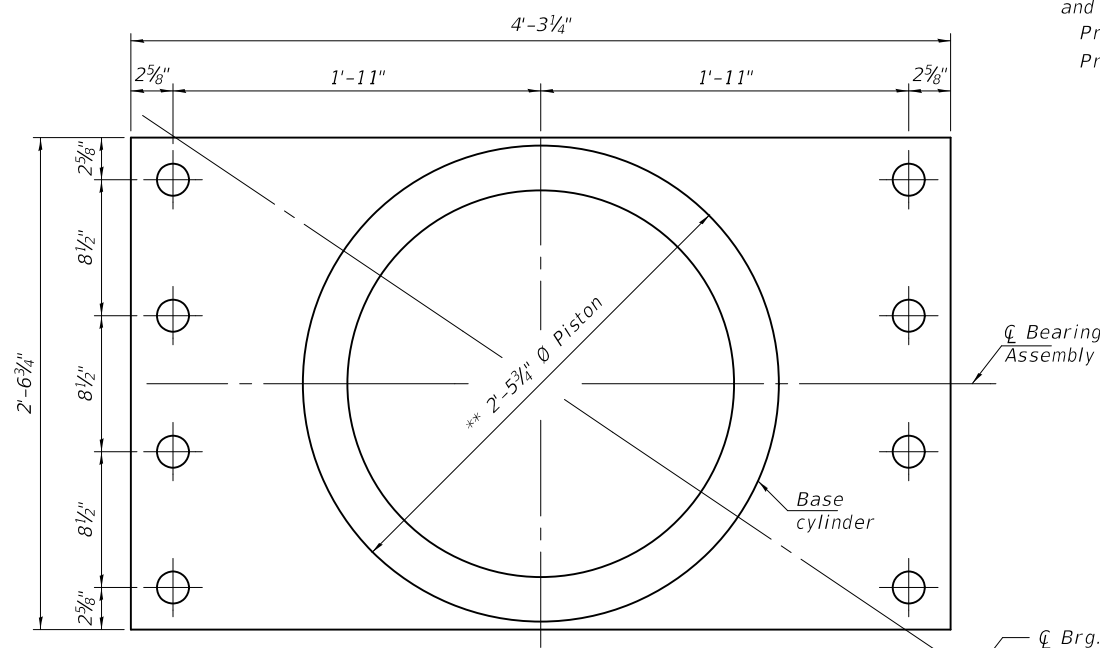
Modifications to the Bearing plates at abutments or piers shall consider the location of the backwall or concrete pedestal dimensions and required expansion length if exceeding the end of the girder.

Provide a 2 3/16" x 4-3 1/4" x 2-6 3/4" fill plate at Girders 5 and 8.

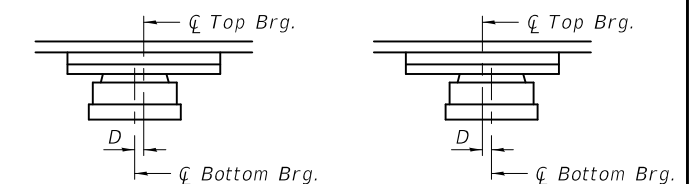
Provide a 2 3/16" x 4-3 1/4" x 2-6 3/4" fill plate at Girders 6 and 7.



**TOP BEARING AND PISTON PLAN**



**BOTTOM BEARING AND BASE CYLINDER PLAN**



BELOW 50° F.

(Move bottom brg. away from fixed brg.)

ABOVE 50° F.

(Move bottom brg. toward fixed brg.)

**SETTING ANCHOR BOLTS AT EXP. BRG.**

D=1/8" per each 100' of expansion for every 15° temp. change from the normal temp. of 50° F.

**DESIGN DATA**

Data	Pier 4
Service Vertical Design Load (kips)	1679
Horizontal Design Load (kips), Hu	336
Design Rotation (rad), Θu ***	0.0026
Total Required Movement (in.)	2.50
Slope for Bevel of Top Brg. R (%)	+4.69

**BILL OF MATERIAL**

Item	Unit	Total
High Load Multi-Rotational Bearings, Guided Expansion, 1700k	Each	4
Anchor Bolts, 1 1/2"	Each	32

DESIGNED - AJR	EXAMINED - <i>Timothy A. Daulton</i>	DATE - JANUARY 31, 2020
CHECKED - JSB	ENGINEER OF STRUCTURAL SERVICES	
DRAWN - Venkat Reddy	PASSED - <i>Carl Berger</i>	REVISED -
CHECKED - AJR JSB	ENGINEER OF BRIDGES AND STRUCTURES	REVISED -

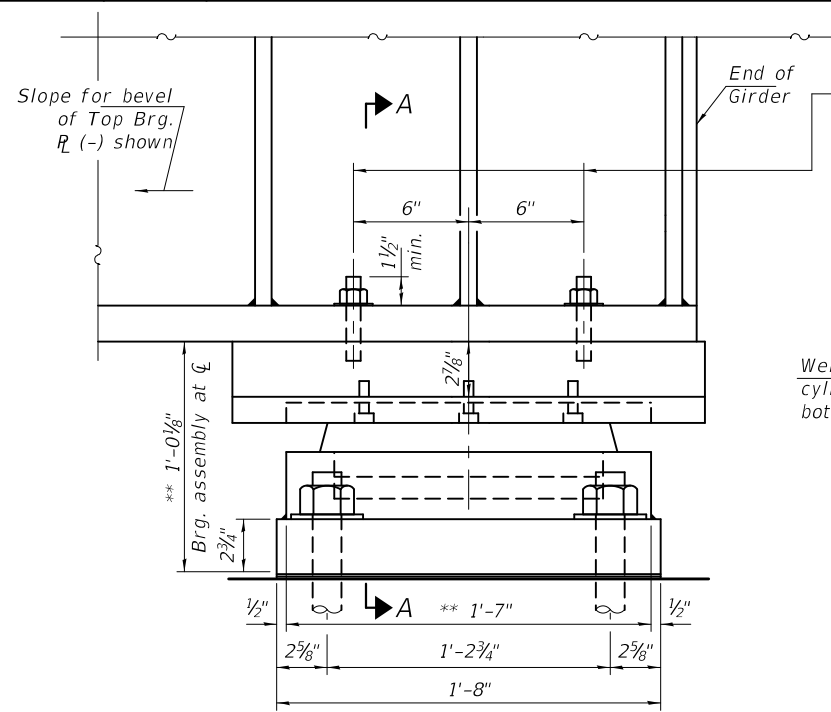
STATE OF ILLINOIS  
DEPARTMENT OF TRANSPORTATION

PIER 4 BEARING DETAILS  
SN 090-0114

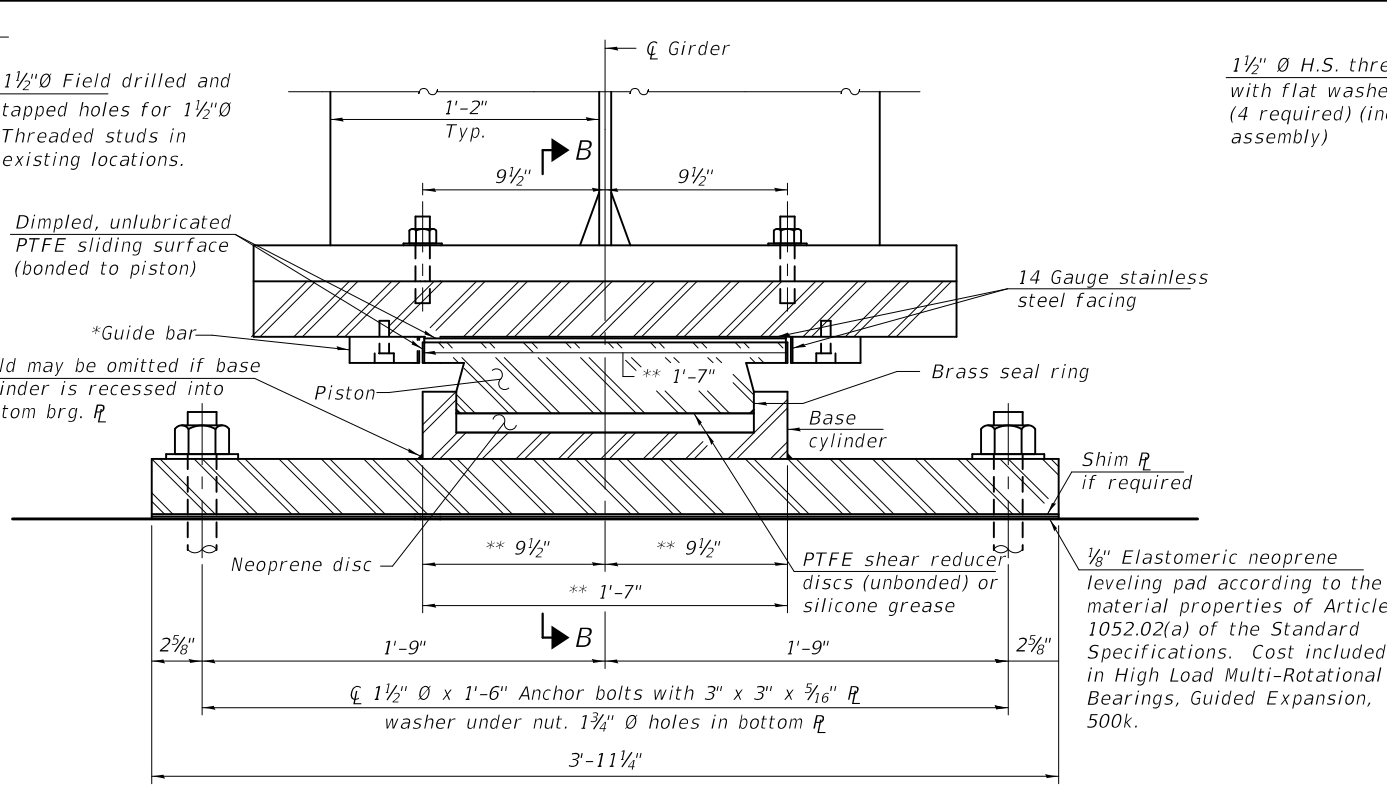
SHEET NO. 15 OF 23 SHEETS

F.A.P. RTE.	SECTION	COUNTY	TOTAL SHEETS	SHEET NO.
693	(12B)BR,BDR,BJR	PEORIA	63	37
CONTRACT NO. 68E79				

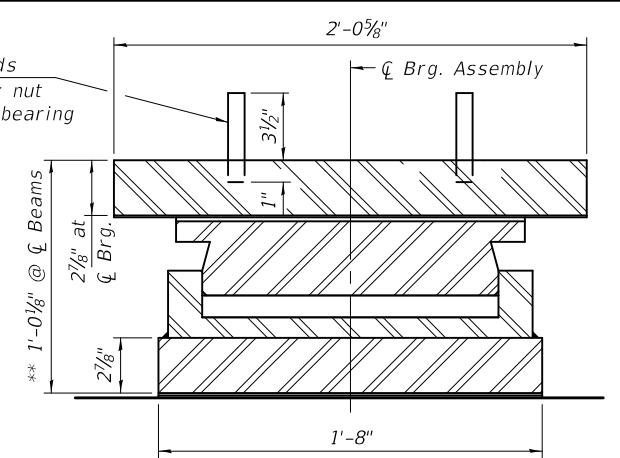
ILLINOIS FED. AID PROJECT



**ELEVATION**



**SECTION A-A**



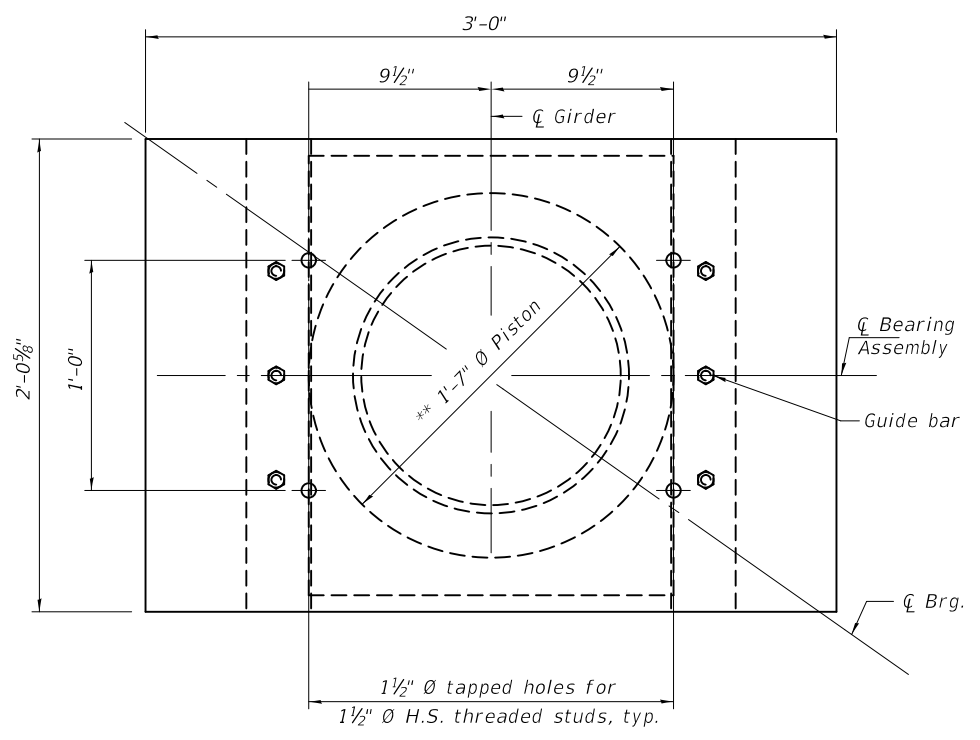
**SECTION B-B**  
(Guide bar and girder omitted for clarity)

\*\* Dimensions may vary depending on Manufacturer's design.  
\*\*\* Rotation allowances for fabrication tolerances (0.005 rad) and installation uncertainties (0.005 rad) excluded.

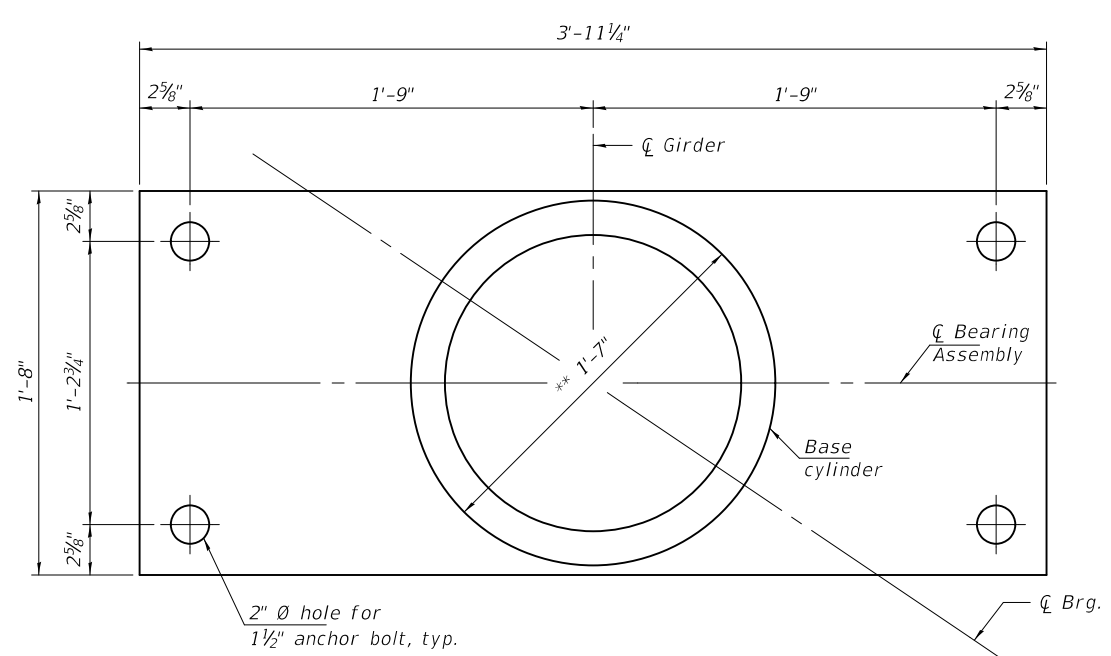
\* As alternates to the bolted connection shown, the guide bars may be connected to the top bearing plate by groove welds or the guide bars and top bearing plate may be fabricated as a single piece. If bolted connection is used, maintain a minimum clearance of 3" from the centerline of the threaded stud to the bolts in the guide bar.

1 1/2" Ø H.S. threaded studs with flat washer and hex nut (4 required) (included in bearing assembly)

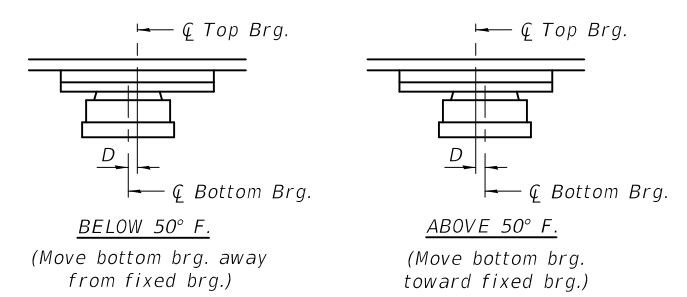
**Notes:**  
Anchor bolts shall be ASTM F1554 all-thread (or an Engineer-approved alternate material) of the grade(s) and diameter(s) specified. The corresponding specified grade of AASHTO M314 anchor bolts may be used in lieu of ASTM F1554.  
Drilled and set anchor bolts shall be installed according to Article 521.06 of the Standard Specifications.  
The structural steel plates of the Bearing Assembly shall conform to the requirements of AASHTO M 270, Grade 50.  
Two 1/8" adjusting shims shall be provided for each bearing in addition to all other plates or shims and placed as shown on bearing details.  
Bearing dimensions and details shown are for a pot type HLMR bearing. Disc type HLMR bearing dimensions and details will vary.  
Bearing Assembly height is estimated based on manufacturer data. Actual bearing height may differ from contract plans. The Contractor shall be responsible verifying bearing heights and adjusting concrete pedestal elevations, if required.  
Modifications to the Bearing plates at abutments or piers shall consider the location of the backwall or concrete pedestal dimensions and required expansion length if exceeding the end of the girder.



**TOP BEARING AND PISTON PLAN**



**BOTTOM BEARING AND BASE CYLINDER PLAN**



**SETTING ANCHOR BOLTS AT EXP. BRG.**  
D=1/8" per each 100' of expansion for every 15° temp. change from the normal temp. of 50° F.

**DESIGN DATA**

Data	E. Abut.
Service Vertical Design Load (kips)	684
Horizontal Design Load (kips), Hu	137
Design Rotation (rad), $\Theta_u$ ***	0.0077
Total Required Movement (in.)	6 5/8
Slope for Bevel of Top Brg. (%)	-4.17

**BILL OF MATERIAL**

Item	Unit	Total
High Load Multi-Rotational Bearings, Guided Expansion, 700k	Each	4
Anchor Bolts, 1 1/2"	Each	16

DESIGNED - AJR  
CHECKED - JSB  
DRAWN - Venkat Reddy  
CHECKED - AJR JSB

EXAMINED - *Timothy A. ...*  
PASSED - *Carl ...*

DATE - JANUARY 31, 2020  
REVISED -  
REVISED -

STATE OF ILLINOIS  
DEPARTMENT OF TRANSPORTATION

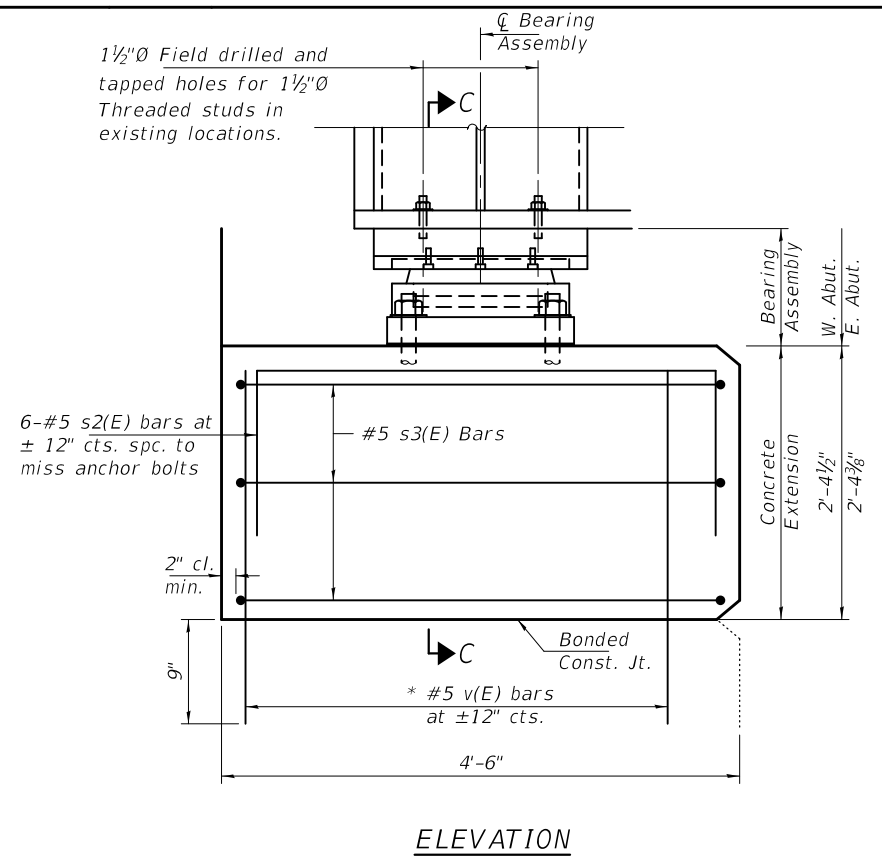
EAST ABUTMENT BEARING DETAILS  
SN 090-0114

SHEET NO. 16 OF 23 SHEETS

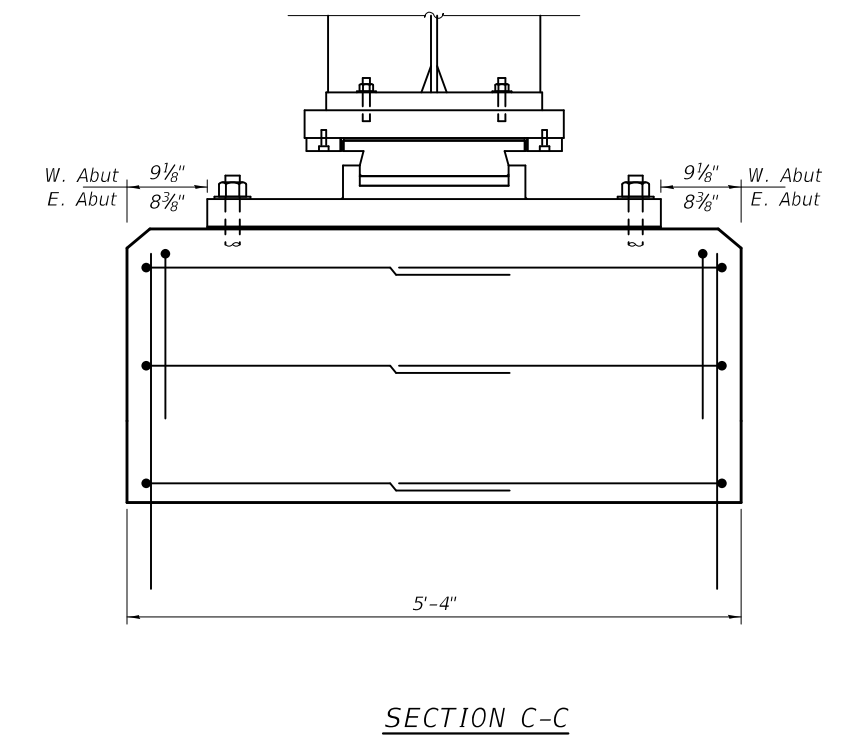
F.A.P. RTE.	SECTION	COUNTY	TOTAL SHEETS	SHEET NO.
693	(12B)BR,BDR,BJR	PEORIA	63	38

CONTRACT NO. 68E79  
ILLINOIS FED. AID PROJECT

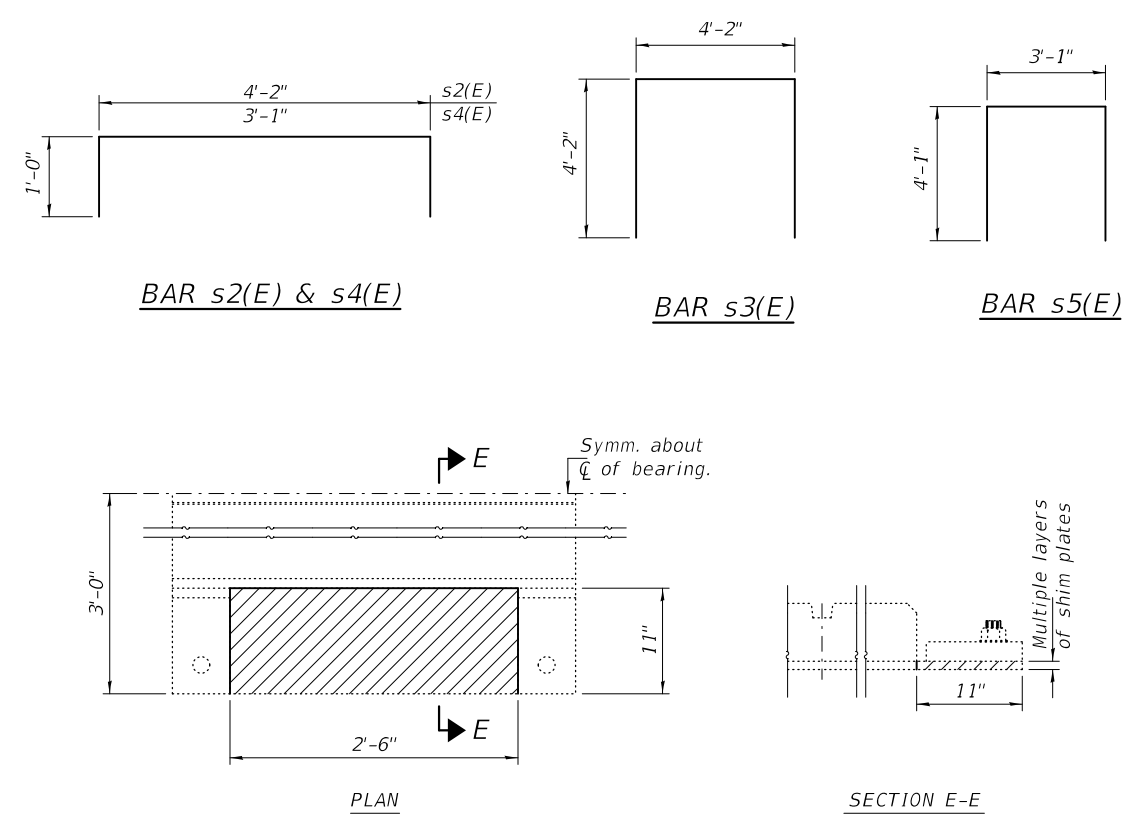
1 1/2"Ø Field drilled and tapped holes for 1 1/2"Ø Threaded studs in existing locations.



ELEVATION



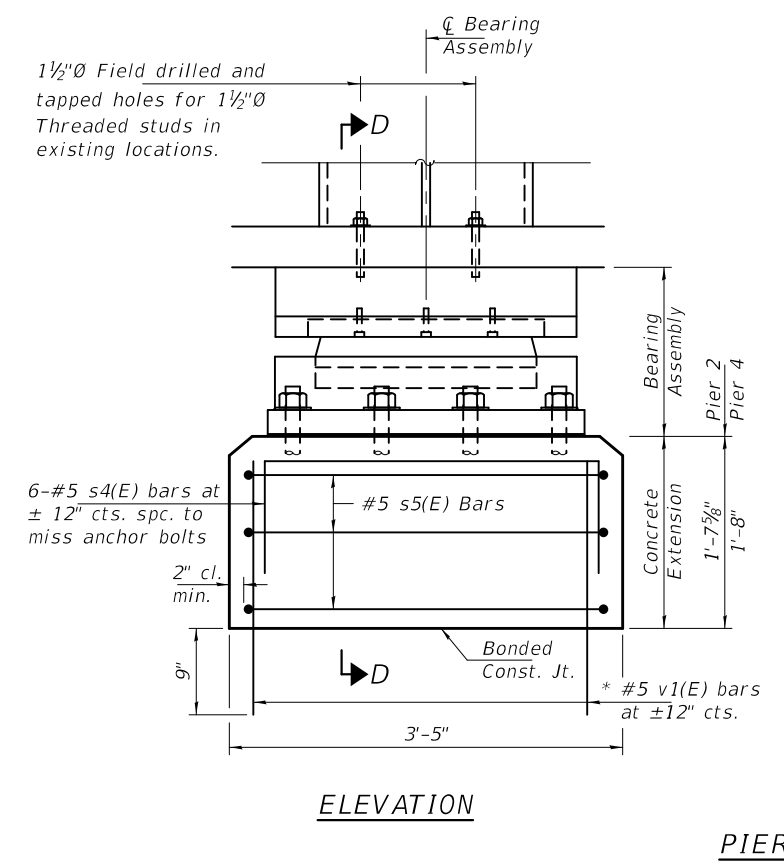
SECTION C-C



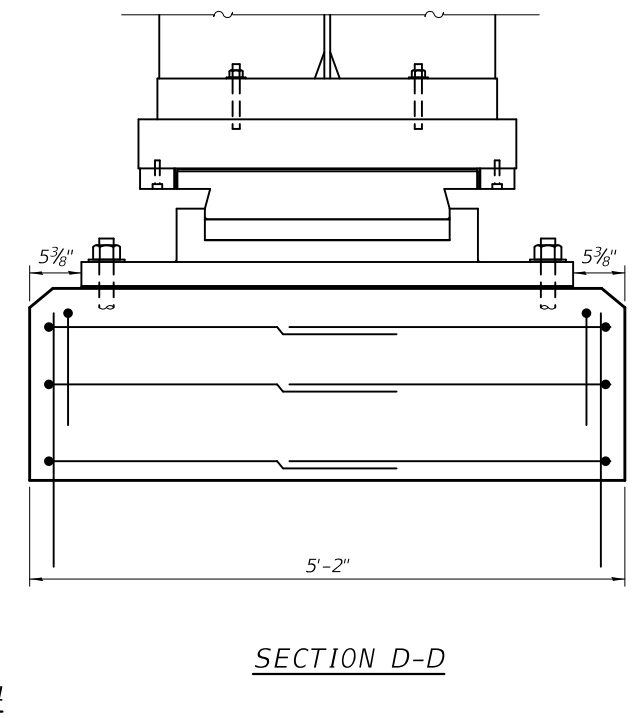
SHIM REMOVAL DETAILS

(Pier 6 - Girder 4)  
Hatched areas indicate shim plate removal. Removal is typical each side of bearing.

Note:  
Prior to ordering any material, the contractor shall verify in the field all bearing height and shim thickness dimensions.  
\*Epoxy grout bars in 9" min. holes according to Article 584 of the Standard Specifications.



ELEVATION



SECTION D-D

PIER 2 & 4

BILL OF MATERIAL

Bar	No.	Size	Length	Shape
s2(E)	48	#5	6'-2"	┌
s3(E)	48	#5	12'-6"	┌
s4(E)	48	#5	5'-1"	┌
s5(E)	48	#5	11'-3"	┌
v(E)	22	#5	2'-11"	—
v1(E)	20	#5	2'-2"	—
Reinforcement Bars, Epoxy Coated			Pound	1860
Structural Steel Removal			Pound	110
Concrete Structures			Cu. Yd.	25.2

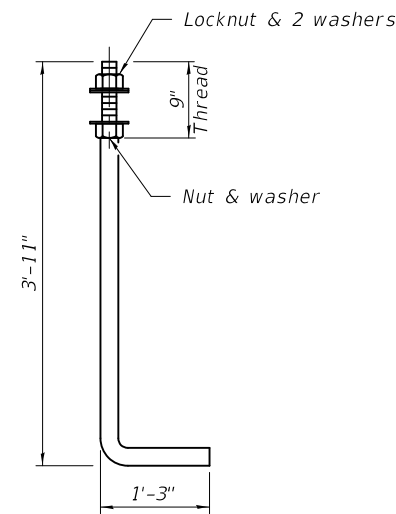
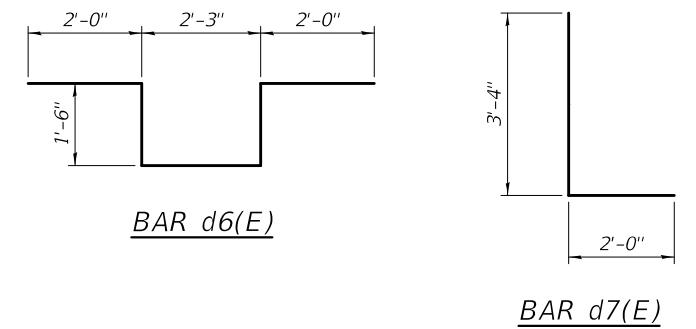
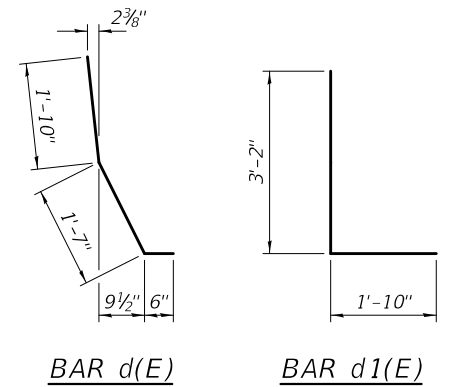
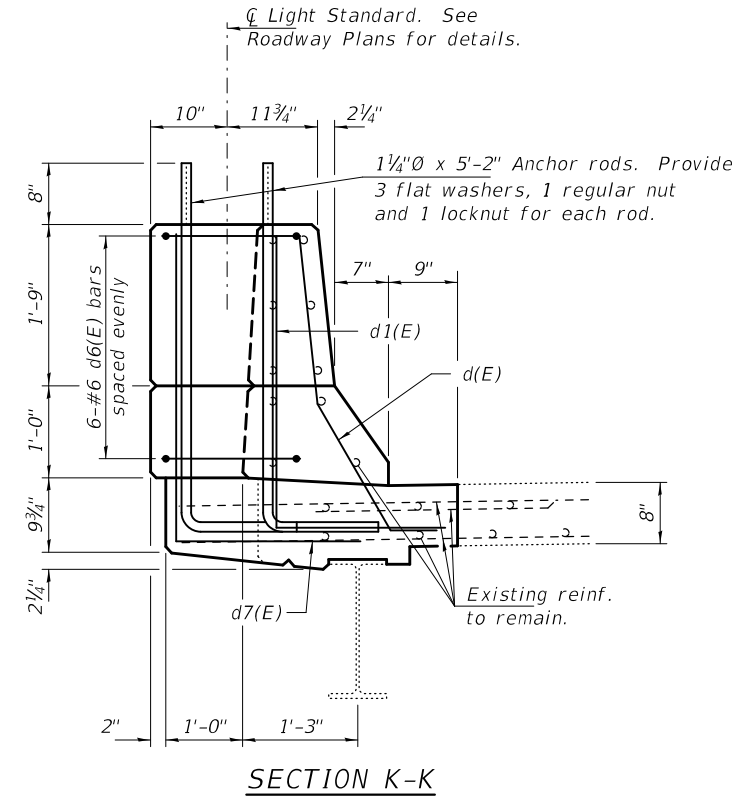
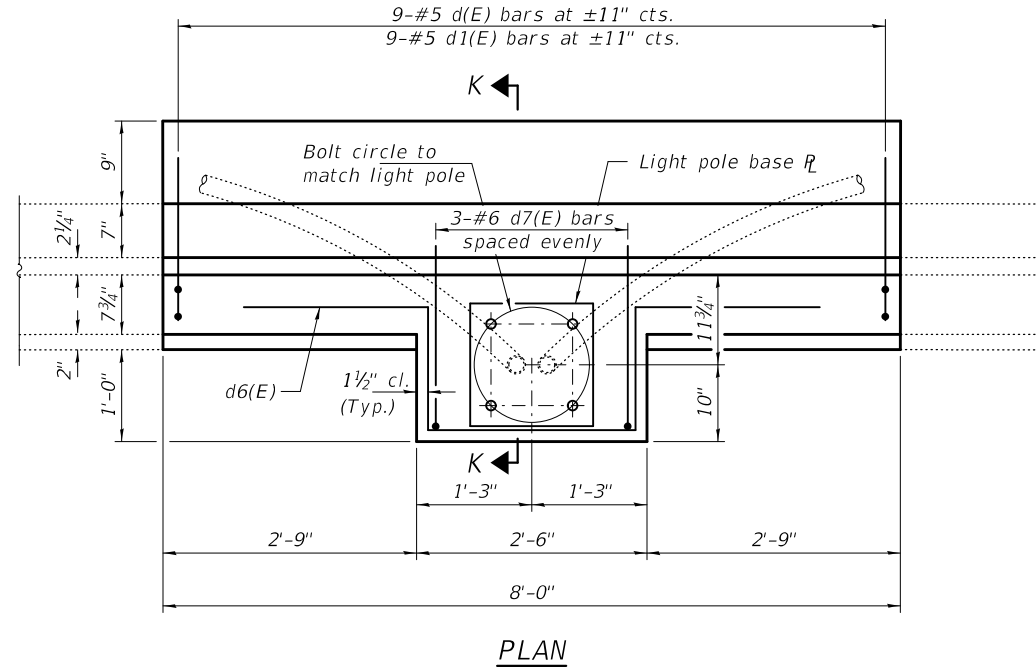
DESIGNED - AJR	EXAMINED - <i>Timothy A. Daulton</i>	DATE - JANUARY 31, 2020
CHECKED - JSB	ENGINEER OF STRUCTURAL SERVICES	
DRAWN - Venkat Reddy	PASSED - <i>Carl Ringer</i>	REVISED -
CHECKED - AJR JSB	ENGINEER OF BRIDGES AND STRUCTURES	REVISED -

STATE OF ILLINOIS  
DEPARTMENT OF TRANSPORTATION

CONCRETE PEDESTAL DETAILS  
SN 090-0114

SHEET NO. 17 OF 23 SHEETS

F.A.P. RTE.	SECTION	COUNTY	TOTAL SHEETS	SHEET NO.
693	(12B)BR,BDR,BJR	PEORIA	63	39
CONTRACT NO. 68E79				
ILLINOIS FED. AID PROJECT				



1/4" Diameter  
(ASTM F 1554 Grade 105) Full length hot dipped galvanized. Paid for as Anchor Bolts, 1/4".

**BILL OF MATERIAL**

Bar	No.	Size	Length	Shape
d(E)	9	#5	3'-11"	L
d1(E)	9	#5	5'-0"	L
d6(E)	6	#6	9'-3"	U
d7(E)	3	#6	5'-4"	L
Concrete Removal			Cu. Yd.	1.7
Concrete Superstructure			Cu. Yd.	1.7
Protective Coat			Sq. Yd.	4.3
Reinforcement Bars, Epoxy Coated			Pound	190
Anchor Bolts, 1/4"			Each	4

DESIGNED - AJR  
CHECKED - JSB  
DRAWN - daburdell  
CHECKED - AJR JSB

EXAMINED  
PASSED

Timothy A. Daburdell  
ENGINEER OF STRUCTURAL SERVICES

Carl R. Rieger  
ENGINEER OF BRIDGES AND STRUCTURES

DATE - JANUARY 31, 2020

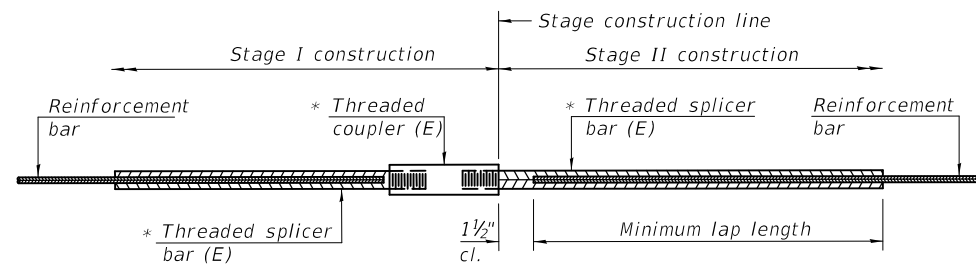
REVISED -  
REVISED -

STATE OF ILLINOIS  
DEPARTMENT OF TRANSPORTATION

LIGHT STANDARD REPAIR DETAILS  
SN 090-0114

SHEET NO. 18 OF 23 SHEETS

F.A.P. RTE.	SECTION	COUNTY	TOTAL SHEETS	SHEET NO.
693	(12B)BR,BDR,BJR	PEORIA	63	40
ILLINOIS			CONTRACT NO. 68E79	
FED. AID PROJECT				

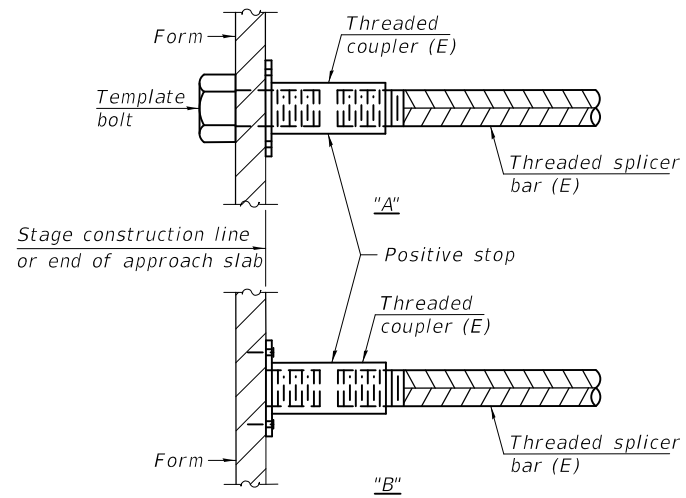


**STANDARD BAR SPLICER ASSEMBLY**

Threaded splicer bar length = min. lap length + 1/2" + thread length

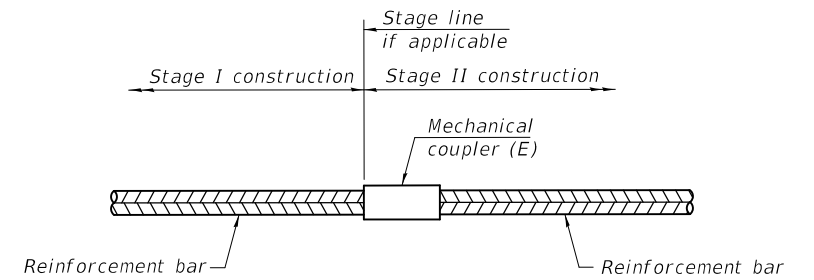
\* Epoxy not required on Bar Splicer Assembly components used in conjunction with black bars.

Location	Bar size	No. assemblies required	Minimum lap length
W. Abut. Deck	#6	32	3'-7"
W. Abut. Appr.	#6	6	4'-0"
E. Abut. Deck	#6	32	3'-7"
E. Abut. Appr.	#6	6	4'-0"
Pier 5	#6	32	3'-7"
Pier 6	#6	8	3'-7"
Pier 9	#6	8	3'-7"



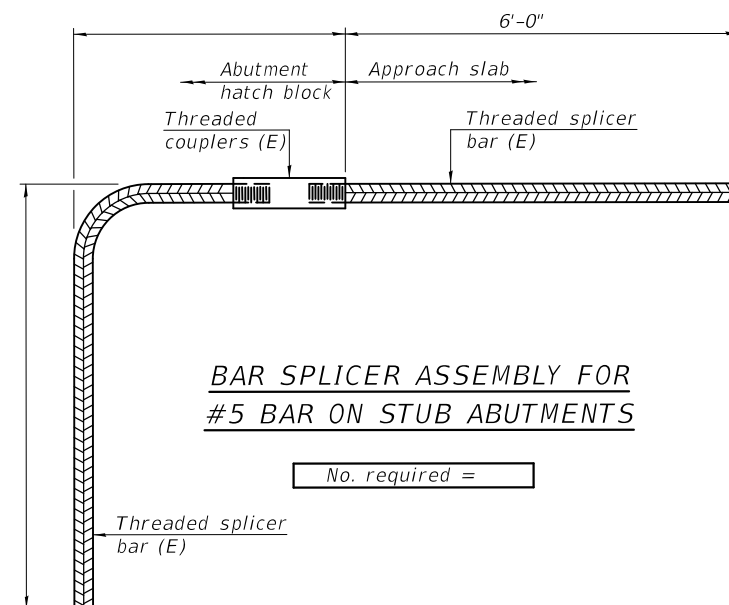
**INSTALLATION AND SETTING METHODS**

"A" : Set bar splicer assembly by means of a template bolt.  
 "B" : Set bar splicer assembly by nailing to wood forms or cementing to steel forms.  
 (E) : Indicates epoxy coating.



**STANDARD MECHANICAL SPLICER**

Location	Bar size	No. assemblies required
W. Abut.	#5	194
E. Abut.	#5	194



**NOTES**

Splicer bars shall be deformed with threaded ends and have a minimum 60 ksi yield strength.  
 All reinforcement shall be lapped and tied to the splicer bars.  
 Bar splicer assemblies shall be epoxy coated according to the requirements for reinforcement bars. See Section 508 of the Standard Specifications.  
 See approved list of bar splicer assemblies and mechanical splicers for alternatives.

BSD-1

2-17-2017

DESIGNED - AJR	EXAMINED	DATE - JANUARY 31, 2020
CHECKED - JSB	<i>Timothy A. Daburdell</i> ENGINEER OF STRUCTURAL SERVICES	
DRAWN - daburdell	PASSED	REVISED -
CHECKED - AJR JSB	<i>Carl R. Berger</i> ENGINEER OF BRIDGES AND STRUCTURES	REVISED -

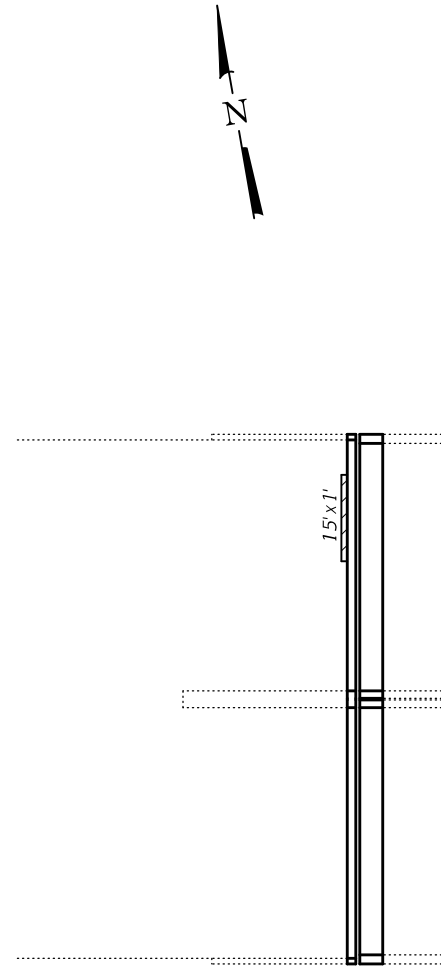
STATE OF ILLINOIS  
DEPARTMENT OF TRANSPORTATION

BAR SPLICER ASSEMBLY AND MECHANICAL SPLICER DETAILS  
SN 090-0114

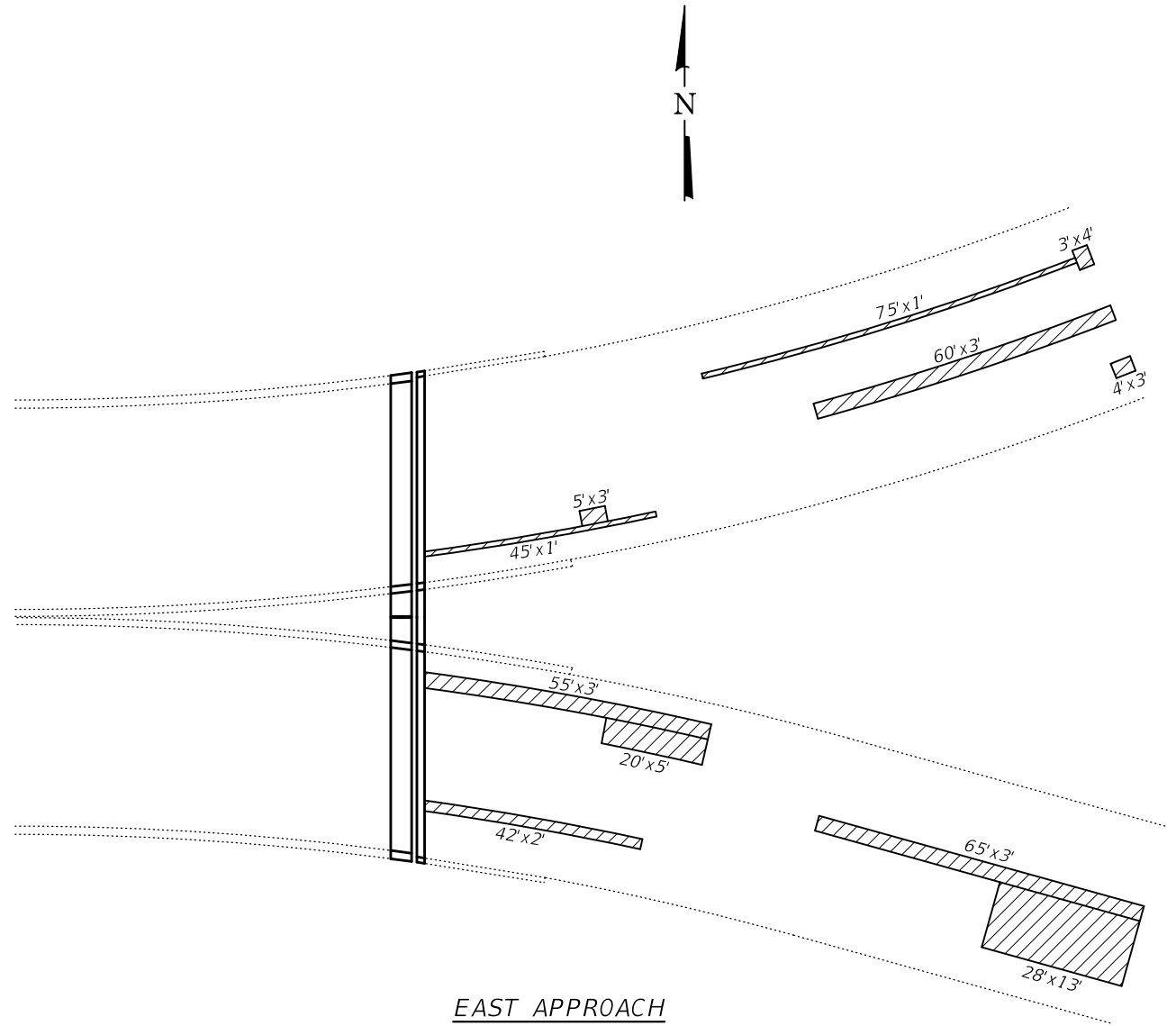
SHEET NO. 19 OF 23 SHEETS

F.A.P. RTE.	SECTION	COUNTY	TOTAL SHEETS	SHEET NO.
693	(12B)BR,BDR,BJR	PEORIA	63	41
CONTRACT NO. 68E79				


ILLINOIS FED. AID PROJECT



WEST APPROACH





EAST APPROACH

 Indicates Deck Slab Repair (Partial).

BILL OF MATERIAL

Item	Unit	Total
Deck Slab Repair (Partial)	Sq. Yd.	140

DESIGNED - AJR	EXAMINED	DATE - JANUARY 31, 2020
CHECKED - JSB	 ENGINEER OF STRUCTURAL SERVICES	
DRAWN - daburdell	PASSED	REVISED -
CHECKED - AJR JSB	 ENGINEER OF BRIDGES AND STRUCTURES	REVISED -

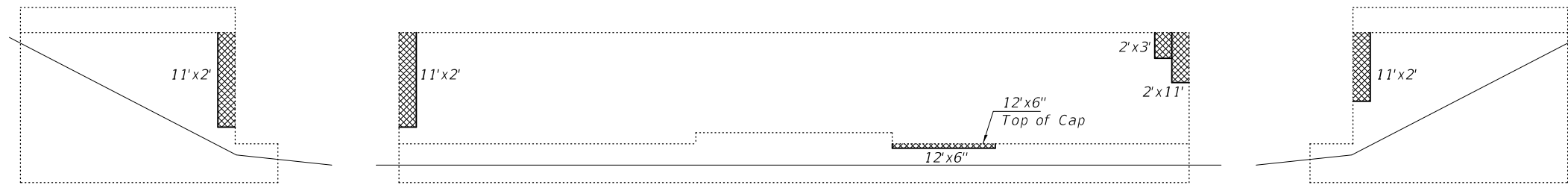
STATE OF ILLINOIS  
DEPARTMENT OF TRANSPORTATION

REPAIR DETAILS  
SN 090-0114

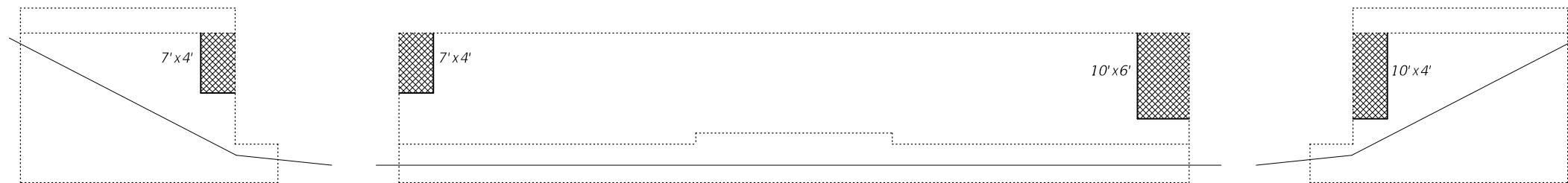
SHEET NO. 20 OF 23 SHEETS

F.A.P. RTE.	SECTION	COUNTY	TOTAL SHEETS	SHEET NO.
693	(12B)BR,BDR,BJR	PEORIA	63	42
ILLINOIS FED. AID PROJECT			CONTRACT NO. 68E79	

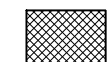




**WEST ABUTMENT**  
(Looking West)



**EAST ABUTMENT**  
(Looking East)

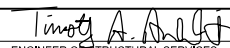
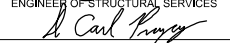
 Structural Repair of Concrete (Depth > 5")

**BILL OF MATERIAL**

Item	Unit	Total
* Structural Repair of Concrete (Depth > 5")	Sq. Ft.	524

\* Quantity includes an additional estimated 262 Sq. Ft.

DESIGNED - AJR  
CHECKED - JSB  
DRAWN - daburdell  
CHECKED - AJR JSB

EXAMINED  
PASSED  
  
  
ENGINEER OF STRUCTURAL SERVICES  
ENGINEER OF BRIDGES AND STRUCTURES

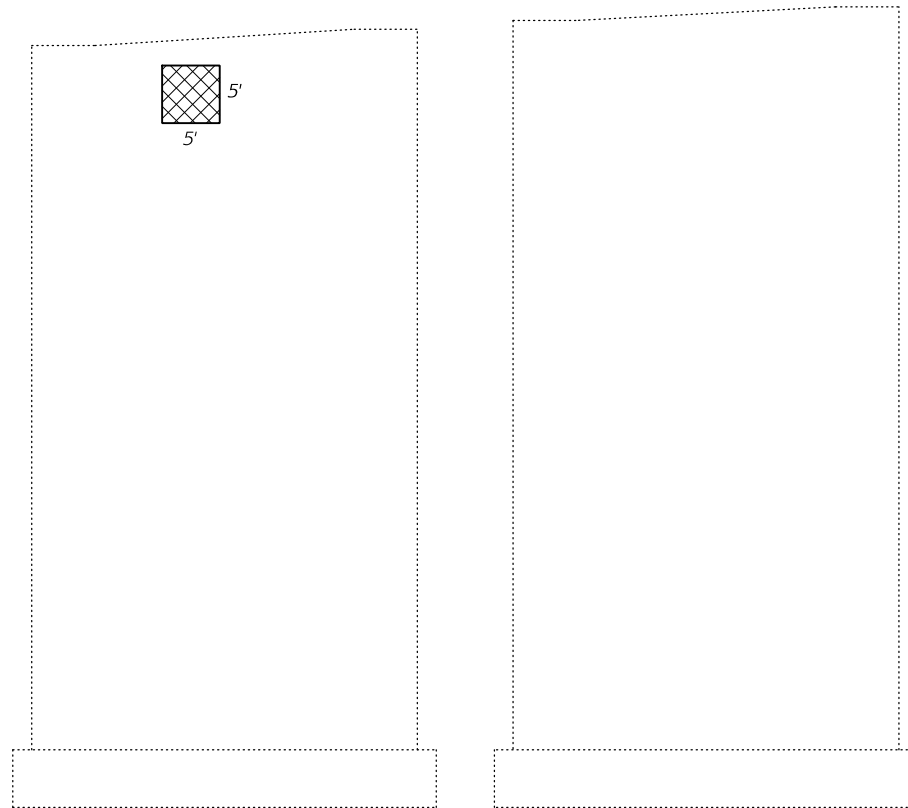
DATE - JANUARY 31, 2020  
REVISED -  
REVISED -

**STATE OF ILLINOIS**  
**DEPARTMENT OF TRANSPORTATION**

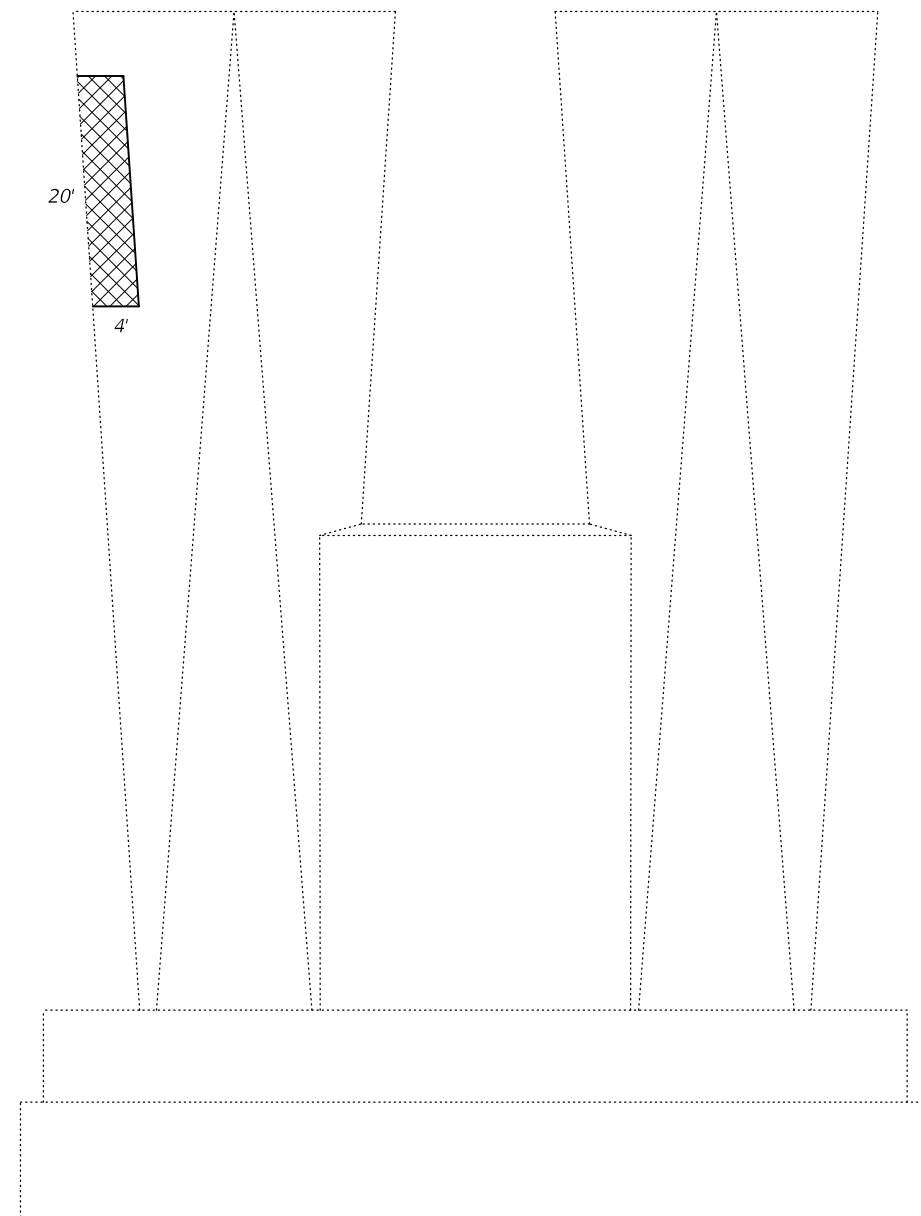
**REPAIR DETAILS**  
**SN 090-0114**

SHEET NO. 21 OF 23 SHEETS

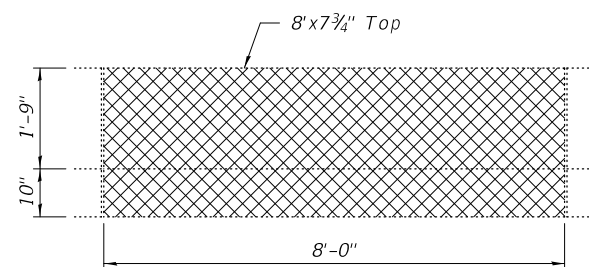
F.A.P. RTE.	SECTION	COUNTY	TOTAL SHEETS	SHEET NO.
693	(12B)BR,BDR,BJR	PEORIA	63	43
CONTRACT NO. 68E79			ILLINOIS   FED. AID PROJECT	




**PIER 5**  
(Looking East)



**PIER 7**  
(Looking West)



**NORTH PARAPET REPAIR**  
(24'-0" East of West Abut.)

 Structural Repair of Concrete (Depth ≤ 5")

**BILL OF MATERIAL**

Item	Unit	Total
* Structural Repair of Concrete (Depth ≤ 5")	Sq. Ft.	262

\* Quantity includes an additional estimated 131 Sq. Ft.

DESIGNED - AJR  
CHECKED - JSB  
DRAWN - daburdell  
CHECKED - AJR JSB

EXAMINED  
PASSED  
*Timothy A. Daulton*  
ENGINEER OF STRUCTURAL SERVICES  
*Carl R. Meyer*  
ENGINEER OF BRIDGES AND STRUCTURES

DATE - JANUARY 31, 2020  
REVISED -  
REVISED -

**STATE OF ILLINOIS**  
**DEPARTMENT OF TRANSPORTATION**

**REPAIR DETAILS**  
**SN 090-0114**

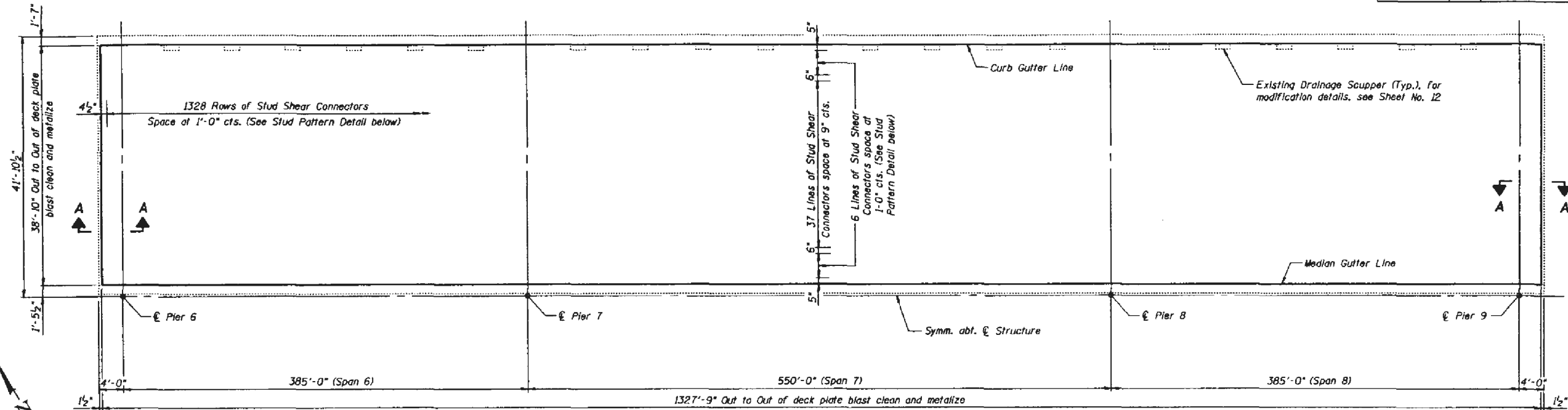
SHEET NO. 22 OF 23 SHEETS

F.A.P. RTE.	SECTION	COUNTY	TOTAL SHEETS	SHEET NO.
693	(12B)BR,BDR,BJR	PEORIA	63	44
ILLINOIS			FED. AID PROJECT	

CONTRACT NO. 68E79

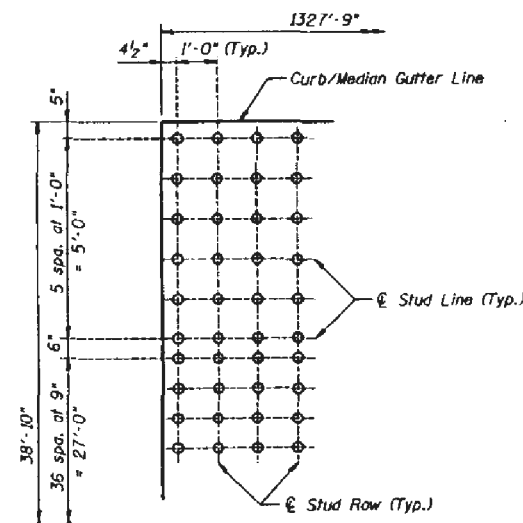
STATE OF ILLINOIS  
DEPARTMENT OF TRANSPORTATION

ROUTE NO.	SECTION	COUNTY	SHEET NO.	TOTAL SHEETS
693	12(B)1	Peoria - Tazewell	34	8

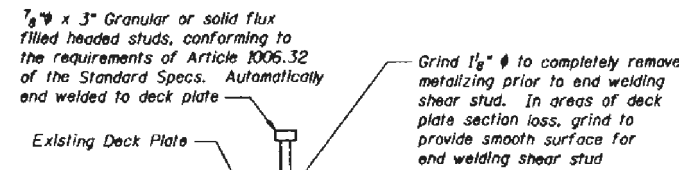


**DECK PLATE PLAN - MAIN RIVER SPANS**  
(Westbound Lanes shown, Eastbound Lanes opposite hand)

Notes: Areas of the deck plate with severe section loss, as determined by the Engineer, shall be provided with a second coating of zinc-metalizing as specified in the Special Provisions; payment for this work shall be made based on the unit bid price for "Additional Zinc-Metalizing". The quantity of 573 square yards for "Additional Zinc-Metalizing" is based on an assumption of 5% of the total steel deck plate area.  
Omit shear studs where existing drainage scuppers interfere with stud placement.  
Individual shear studs may be shifted transversely and/or longitudinally up to 2" to avoid existing deck plate butt welds.  
Individual shear studs may be shifted transversely and/or longitudinally to avoid areas of the plate with severe section loss only as approved by the Engineer.  
See Sheet No. 10 for incidental blast cleaning and metalizing of drainage scuppers.

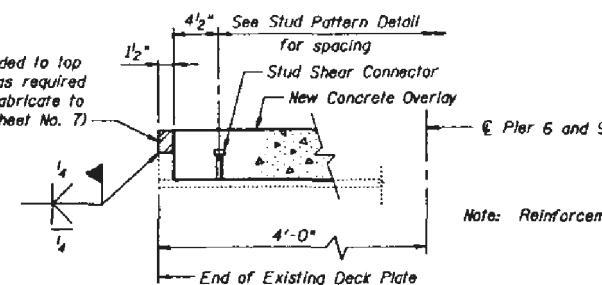


STUD PATTERN DETAIL



STUD SHEAR CONNECTOR DETAIL

\* New Bar 1 1/2" x 2 1/4" welded to top of existing bar, splice as required (Full width of overlay, fabricate to cross slope, refer to Sheet No. 7)



SECTION A-A

\* Cost of new bar, shall be included in the cost bid associated with the joints, at Piers 6 and 9. "Removal and Replacement of Preformed Elastomeric Compression Joint Seal".

**BILL OF MATERIAL**

ITEM	UNIT	TOTAL
Blast Clean Steel Deck Plate	Sq. Yd.	11,458
Zinc-Metalize Steel Deck Plate (Typical)	Sq. Yd.	11,458
Additional Zinc-Metalizing	Sq. Yd.	573
Stud Shear Connectors	Each	130,144

**MAIN SPAN MODIFICATIONS - 2**  
**F.A.P. ROUTE 693 (IL 9) OVER**  
**ILLINOIS RIVER**  
**F.A.P. ROUTE 693 (IL 9) SECTION 12(B)1**  
**PEORIA-TAZEWELL COUNTIES**  
**STATION 96+50**  
**STRUCTURE NO. 090-0114**

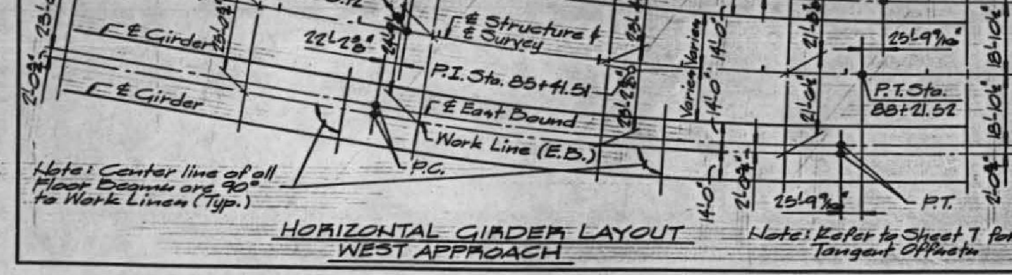
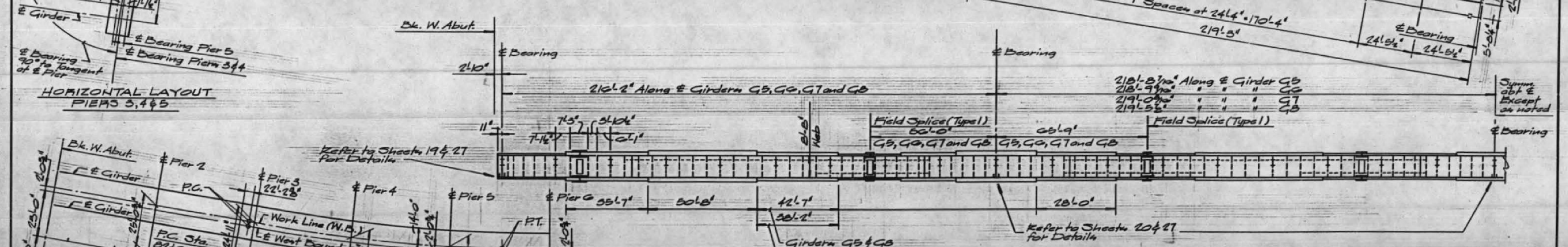
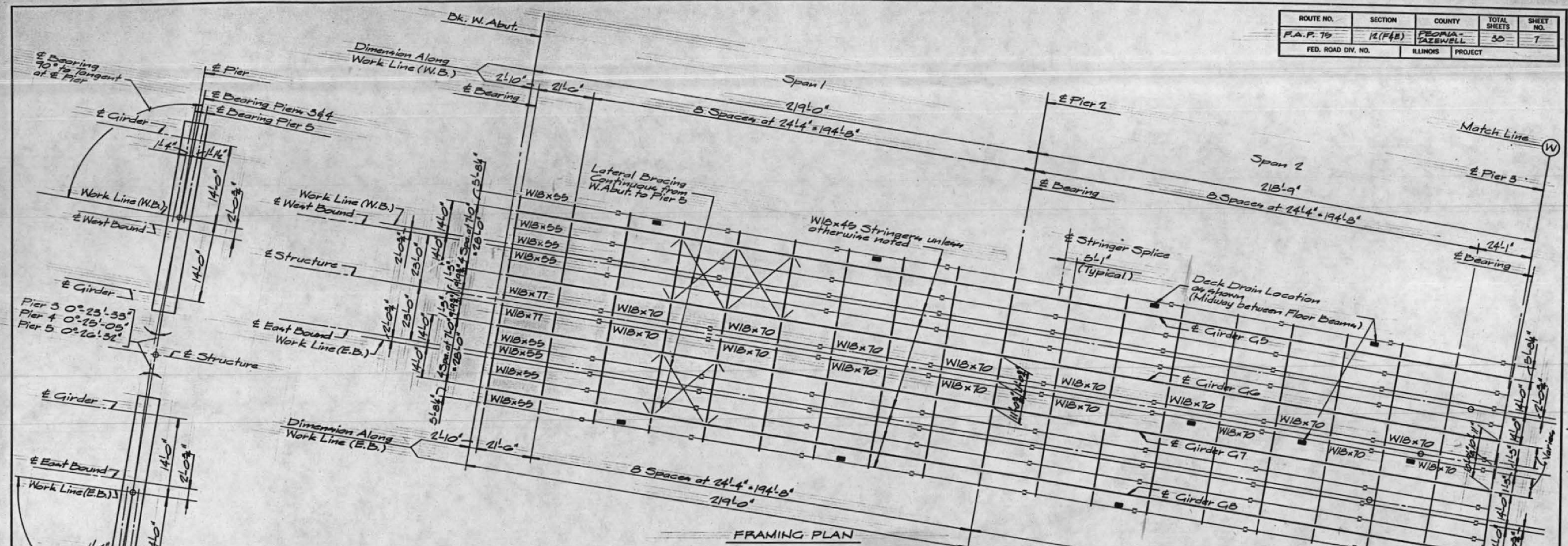
**FOR INFORMATION ONLY**

DESIGNED	K.E.E.
CHECKED	Y.S.S.
DRAWN	P.R.C.
CHECKED	Y.S.S.



6/7/99

ROUTE NO.	SECTION	COUNTY	TOTAL SHEETS	SHEET NO.
F.A.P. 75	12(F&E)	PEORIA-TAZEWELL	30	7
FED. ROAD DIV. NO.	ILLINOIS	PROJECT		



**LAYOUT CURVE DATA**

West Bound	Work Line (W.B.)	Work Line (E.B.)
$\Delta = 9^{\circ}49'28.1''$	$\Delta = 9^{\circ}49'28.1''$	$\Delta = 9^{\circ}49'28.1''$
$D = 1^{\circ}45'$	$D = 1^{\circ}45'04''$	$D = 1^{\circ}44'56''$
$R = 5274.04'$	$R = 5271.98'$	$R = 5276.11'$
$T = 281.59'$	$T = 281.21'$	$T = 281.57'$
$L = 561.40'$	$L = 561.05'$	$L = 561.75'$

**GIRDER ELEVATION**  
GIRDERS G5, G6, G7 & G8  
For Details not shown see Sheet 7

**FOR INFORMATION ONLY**

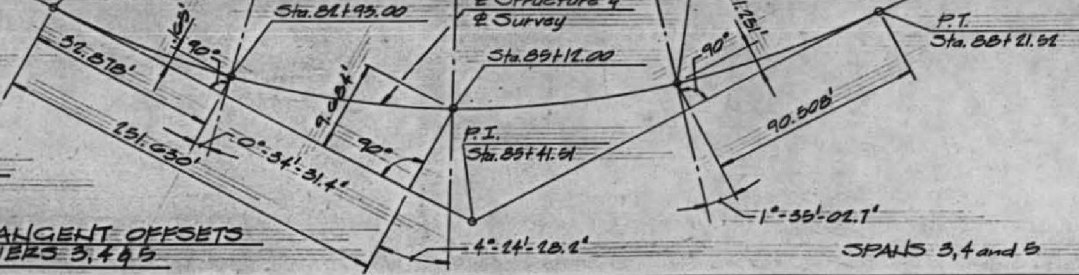
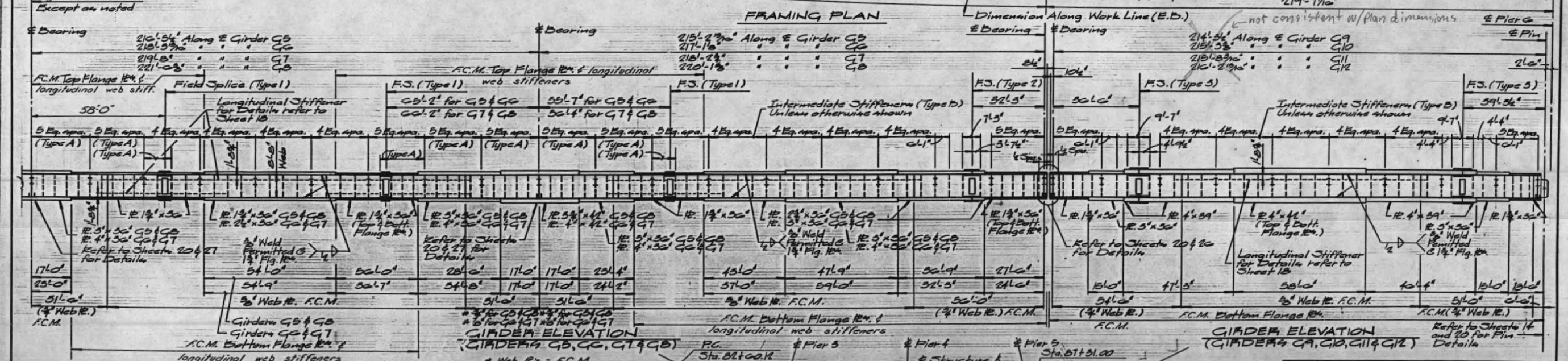
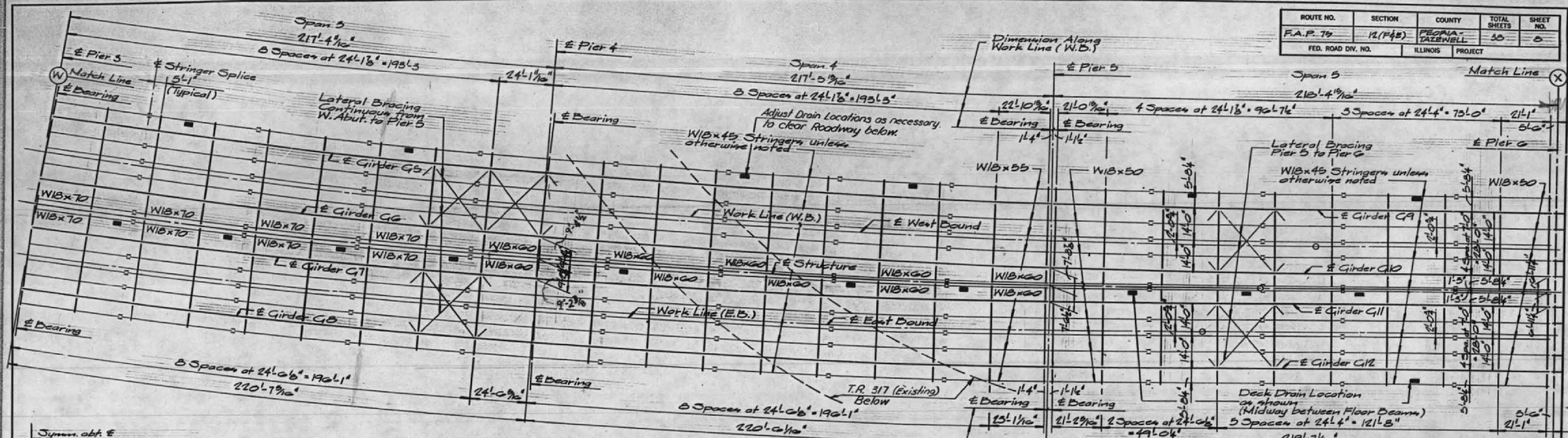
STATE OF ILLINOIS  
DEPARTMENT OF TRANSPORTATION  
FRAMING PLAN AND  
GIRDER ELEVATIONS  
PROJECT:  
ILL. 9 over ILLINOIS RIVER  
F.A.P. 75 SECTION 12(F&E)  
PEORIA-TAZEWELL COUNTIES  
STA. 96+00

THE ENGINEERS COLLABORATIVE  
CHICAGO ILLINOIS

SHEET  
6 of 37



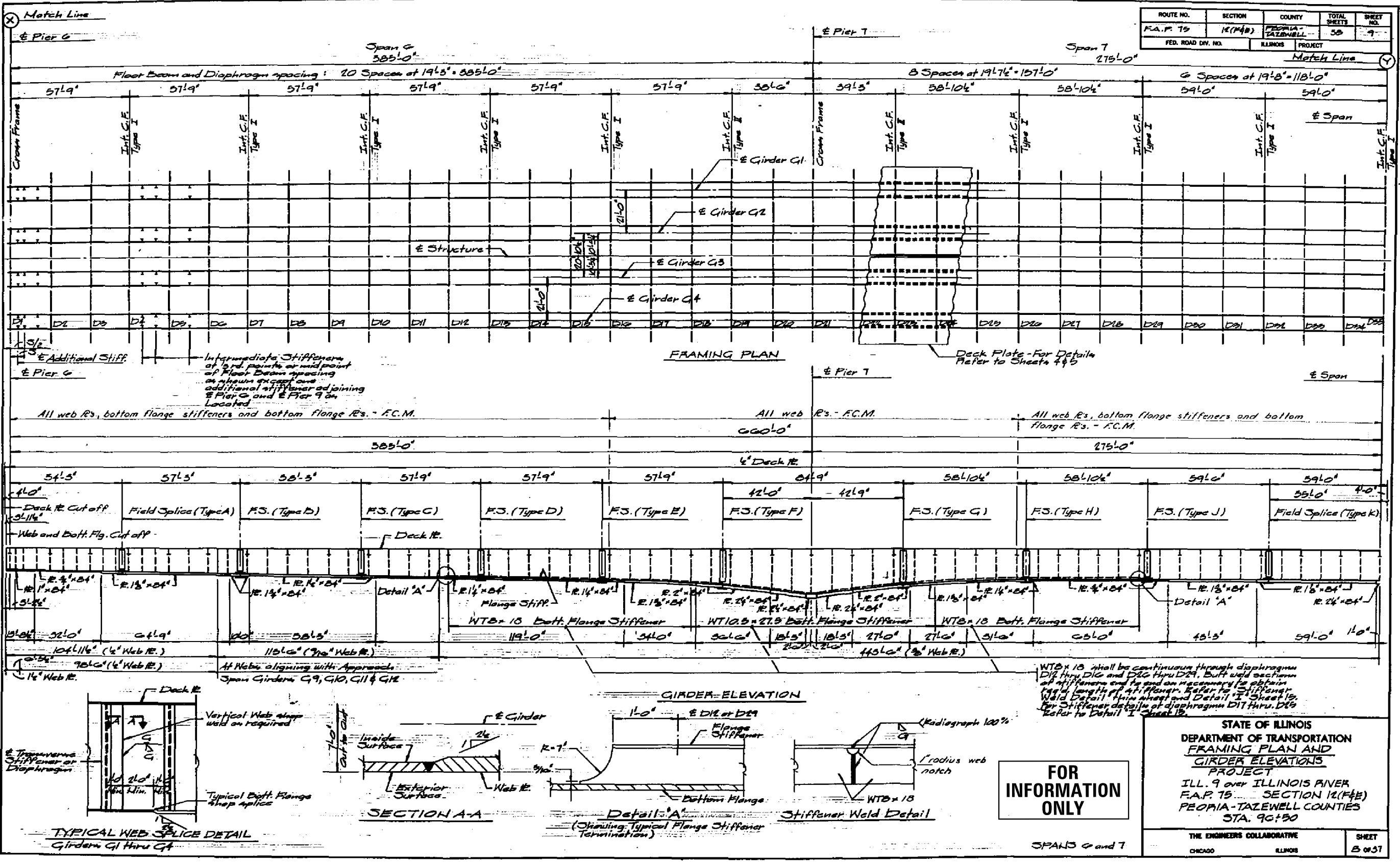
ROUTE NO.	SECTION	COUNTY	TOTAL SHEETS	SHEET NO.
F.A.P. 79	12(F&E)	PEORIA-TAZEWELL	30	5
FED. ROAD DIV. NO.	ILLINOIS	PROJECT		



**FOR INFORMATION ONLY**

STATE OF ILLINOIS  
 DEPARTMENT OF TRANSPORTATION  
 FRAMING PLAN AND  
 GIRDER ELEVATIONS  
 PROJECT:  
 ILL. 9 over ILLINOIS RIVER  
 F.A.P. 79 SECTION 12(F&E)  
 PEORIA-TAZEWELL COUNTIES  
 STA. 96+90

THE ENGINEERS COLLABORATIVE  
 CHICAGO ILLINOIS  
 SHEET T OF 57



ROUTE NO.	SECTION	COUNTY	TOTAL SHEETS	SHEET NO.
F.A.P. 75	12(F&E)	PEORIA-TAZEWELL	58	9
FED. ROAD DIV. NO.	ILLINOIS	PROJECT		

DESIGNED - AJR  
 CHECKED - JSB  
 DRAWN - daburdell  
 CHECKED - AJR JSB

EXAMINED  
 PASSED  
 Timothy A. [Signature]  
 ENGINEER OF STRUCTURAL SERVICES  
 [Signature]  
 ENGINEER OF BRIDGES AND STRUCTURES

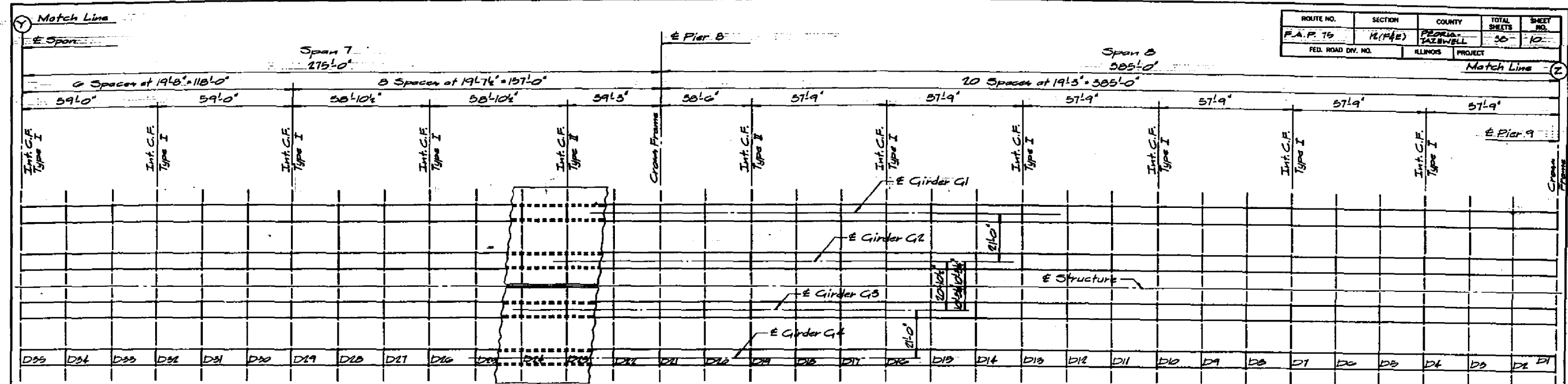
DATE - JANUARY 31, 2020  
 REVISED -  
 REVISED -

STATE OF ILLINOIS  
 DEPARTMENT OF TRANSPORTATION

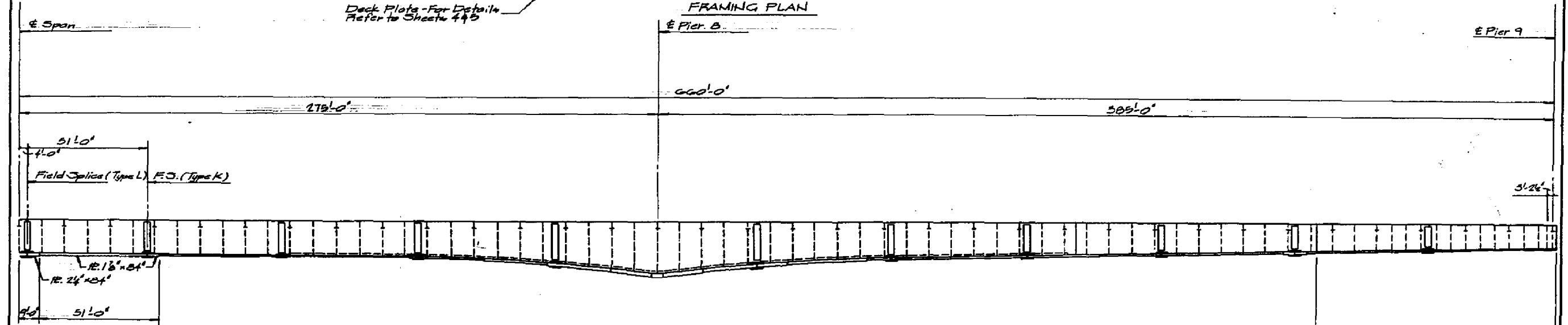
EXISTING PLAN SHEET - FOR INFORMATION ONLY  
 SN 090-0114  
 SHEET NO. 23C OF 23 SHEETS

F.A.P. RTE.	SECTION	COUNTY	TOTAL SHEETS	SHEET NO.
693	(12)BR,BDR,BJR	PEORIA	63	45C
CONTRACT NO. 68E79				
ILLINOIS FED. AID PROJECT				

ROUTE NO.	SECTION	COUNTY	TOTAL SHEETS	SHEET NO.
F.A.P. 75	K(F&E)	PEORIA-TAZEWELL	50	10
FED. ROAD DIV. NO.	ILLINOIS	PROJECT	Match Line - 2	



FRAMING PLAN



GIRDER ELEVATION

For information not shown refer to Girder Elevation sheets at Match Line Y except as noted.

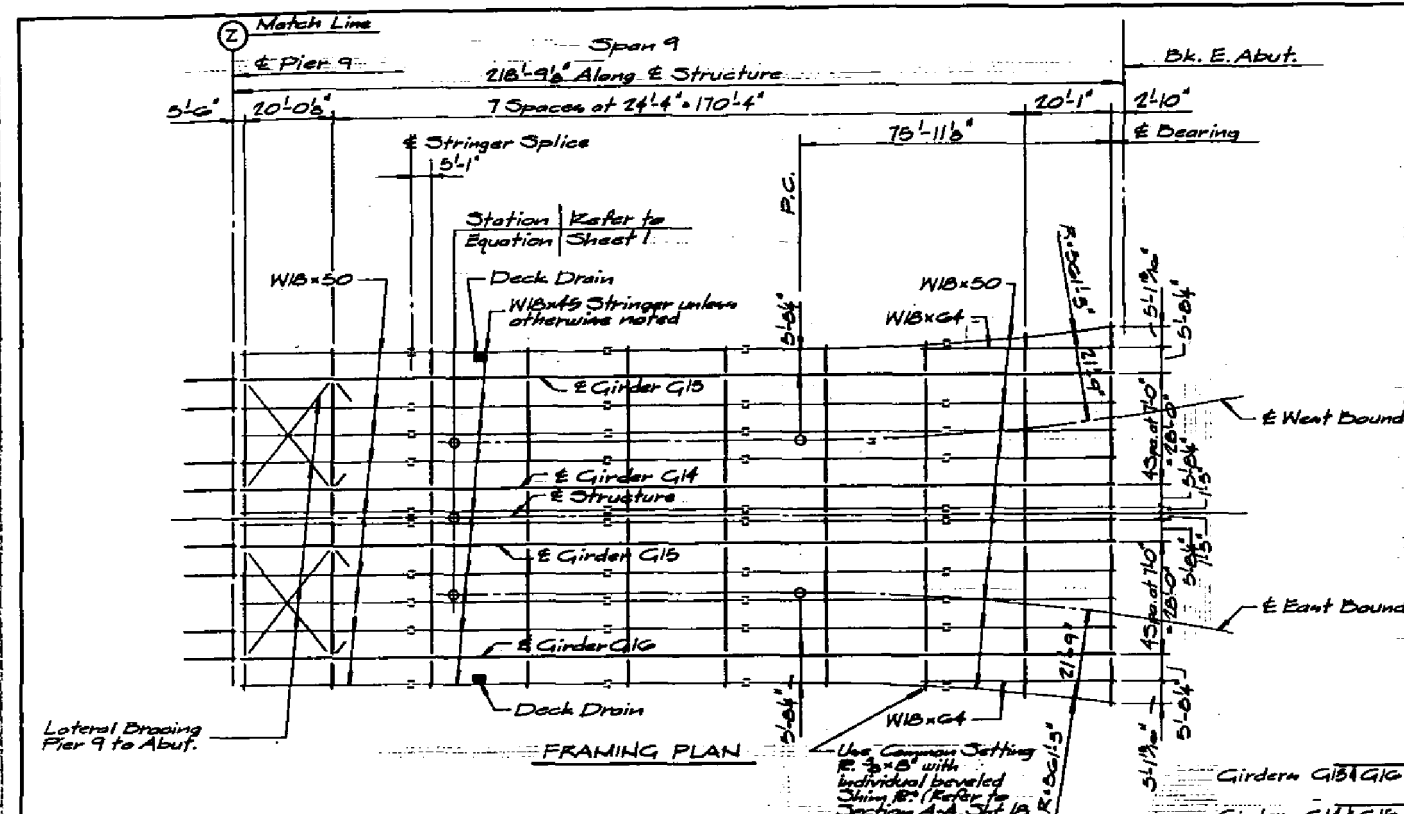
FOR INFORMATION ONLY

STATE OF ILLINOIS  
 DEPARTMENT OF TRANSPORTATION  
 FRAMING PLAN AND  
 GIRDER ELEVATIONS  
 PROJECT:  
 ILL. 9 over ILLINOIS RIVER  
 F.A.P. 75 SECTION K(F&E)  
 PEORIA-TAZEWELL COUNTIES  
 STA. 90+00

THE ENGINEERS COLLABORATIVE CHICAGO ILLINOIS  
 SHEET 9 OF 37

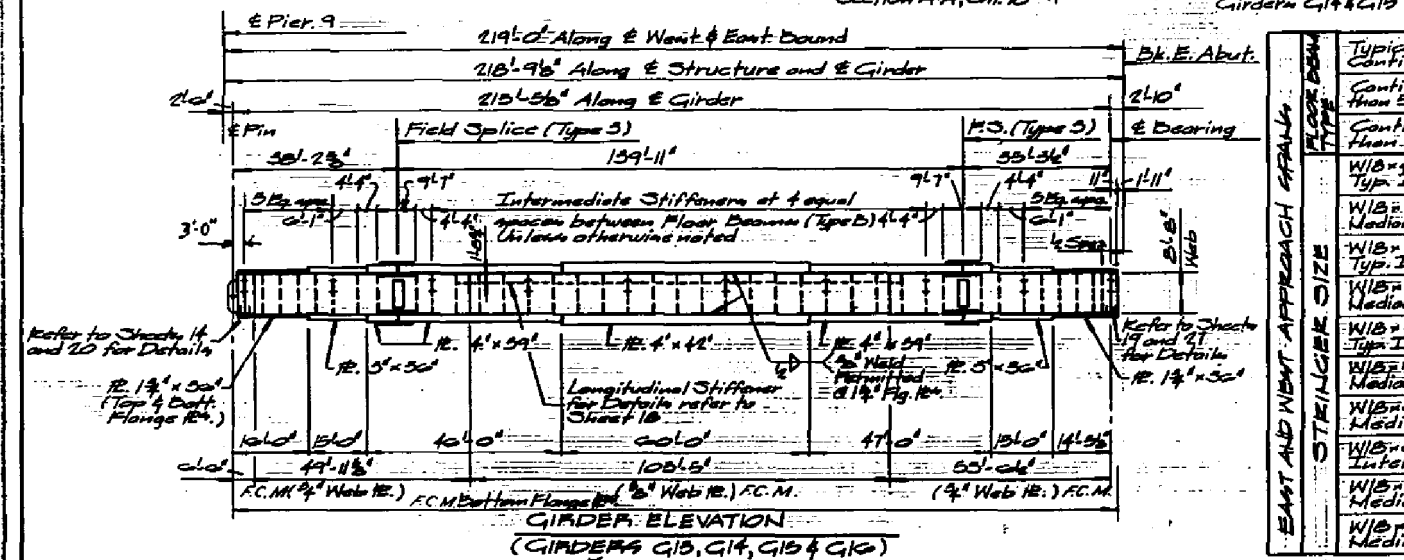


ROUTE NO.	SECTION	COUNTY	TOTAL SHEETS	SHEET NO.
F.A.P. 75	12(F+E)	PEORIA-TAZEWELL	30	11
FED. ROAD DIV. NO.	ILLINOIS	PROJECT		



**TABLE OF MOMENTS AND REACTIONS**

LOCATION	I (in <sup>4</sup> )	DL (K/ft)	ML (K)	MR (K)	MR (K)	Ntotal (K)	R <sub>1</sub> (K)	R <sub>2</sub> (K)	R <sub>3</sub> (K)	R <sub>4</sub> (K)
West Abutment										
0.5 Span 1	676914	4.951	12924	4292	2118	25679	281	410	107	49
Pier 2	1201797	4.951	27154	5900	2711	25769	224	1247	272	122
0.5 Span 2	1102004	4.951	1440	3480	1004	12024	19.7			
Pier 3	200001	5.027	17844	5050	2510	20140	24.1	1014	297	118
0.5 Span 3	1102004	5.027	7070	3550	1042	12024	20.0			
Pier 4	1201797	5.184	28858	6110	2825	31800	29.7	1515	282	129
0.5 Span 4	676914	5.184	18255	4840	2154	25359	24.7			
Pier 5 (Left)							454	111	50	59
Pier 5 (Right)							507	97	45	709
0.5 Span 5	1128292	5.22	20442	5840	2607	20409	23.0			
West Abutment							504	128	59	291
0.5 Span 1	840587	6.029	22820	5540	2921	12009	21.0			
Pier 2	1151680	6.029	32498	7040	3228	15010	23.9	1592	320	152
0.5 Span 2	200001	5.904	8850	4140	1805	14801	17.1			
Pier 3	910204	5.859	20404	5830	2704	29408	21.8	1179	290	144
0.5 Span 3	200001	5.027	8350	3900	1822	14152	12.4			
Pier 4	1151680	5.414	30870	6540	3207	29917	23.0	1379	300	138
0.5 Span 4	840587	5.44	19190	5120	2373	20049	19.4			
Pier 5 (Left)							459	117	54	227
Pier 5 (Right)							507	100	40	719
0.5 Span 5	1128292	5.21	20870	6080	2782	29172	23.8			
Pier 6							987	375	44	1404
0.5 Span 6	1929197	5.559	23429	18417	1809	48081	23.9			
Pier 7	2012200	4.542	90150	20190	3215	129201	20.1	2018	709	92
0.5 Span 7	200001	5.840	10090	21500	1510	29410	24.7			
Pier 8	2012200	4.542	90150	20190	3215	129201	20.1	2018	709	92
0.5 Span 8	1929197	5.559	23429	18417	1809	48081	23.9			
Pier 9							987	375	44	1404
0.5 Span 9	1070000	5.14	27190	5800	2009	20259	22.4			
East Abutment							584	100	47	751
0.5 Span 9	1070000	5.28	28452	5840	2000	21428	23.9			
East Abutment							557	97	45	679
Typical 5/8" Cantilever							552	13.8	70	49
Mid Span	6040		255	404	120	789	23.8			
Cantilever greater than 5/8" to 7/4" Cantilever	5950		192	44	123	789	17.5	20	44	14
Mid Span	8250		192	44	123	789	17.5			
Cantilever greater than 7/4" Cantilever	8250		124	415	124	600	19.2	101	59	16
Mid Span	11380		124	415	124	600	17.5			
W18x45 Typ. Interior	Interior Support	700	1.05	25	75	22	100	24.2	20	20
Mid Span	Mid Span			27	82	24	133	20.2		
W18x45 Median or Facia	Interior Support	700	1.09	27	50	11	114	17.3	21	19
Mid Span	Mid Span			28	40	14	88	15.4		
W18x50 Typ. Interior	Interior Support	802	1.05	27	80	20	181	24.4	27	20
Mid Span	Mid Span			45	40	29	170	22.8		
W18x50 Median or Facia	Interior Support	802	1.09	29	40	14	129	17.4	27	19
Mid Span	Mid Span			40	51	10	113	19.2		
W18x55 ** Typ. Interior	Interior Support	891	1.09	27	80	20	181	24.4	29	20
Mid Span	Mid Span			45	40	29	170	22.8		
W18x55 ** Median or Facia	Interior Support	891	1.09	27	50	15	124	16.4	30	20
Mid Span	Mid Span			40	54	17	117	16.4		
W18x55 ** Median	Interior Support	890	1.51	34	51	15	131	14.0	32	25
Mid Span	Mid Span			34	51	15	122	11.1		
W18x70 ** Interior	Interior Support	1080	Varign	24	70	21	115	11.7		
Mid Span	Mid Span		.8 Max.	21	67	20	120	11.0		
W18x70 ** Median	Interior Support	1100	1.07	103	75	22	180	18.4	41	30
Mid Span	Mid Span			43	80	20	157	14.0		
W18x77 ** Interior Support	Interior Support	1290	1.07	107	99	29	231	19.9	43	30
Mid Span	Mid Span			72	101	30	209	17.2		



EAST AND WEST APPROACH SPALLS

\*\* LL+I Deflection Controls  
\*\*\* Based on Moment and Net Section at Field Splice Location

\* Bottom Flange Stress

FOR  
INFORMATION  
ONLY

**STATE OF ILLINOIS**  
DEPARTMENT OF TRANSPORTATION  
**FRAMING PLAN AND**  
**GIRDER ELEVATIONS**  
PROJECT:  
ILL. 9 over ILLINOIS RIVER  
F.A.P. 75 SECTION 12(F+E)  
PEORIA-TAZEWELL COUNTIES  
STA. 96720

THE ENGINEERS COLLABORATIVE  
CHICAGO ILLINOIS

SHEET  
10 of 37

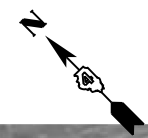


SCHEDULE OF QUANTITIES FOR ELECTRICAL WORK - PEKIN BRIDGE		
ITEM DESCRIPTION	UNIT	TOTAL QTY.
UNDERGROUND CONDUIT, PVC, 3/4" DIA.	FOOT	600.0
UNDERGROUND CONDUIT, PVC, 1 1/2" DIA.	FOOT	130.0
CONDUIT ATTACHED TO STRUCTURE, 2" DIA., STAINLESS STEEL	FOOT	300.0
JUNCTION BOX, STAINLESS STEEL, ATTACHED TO STRUCTURE, 12" X 12" X 6"	EACH	2.0
JUNCTION BOX, STAINLESS STEEL, ATTACHED TO STRUCTURE, 12" X 12" X 8"	EACH	2.0
LUMINAIRE, LED, ROADWAY, OUTPUT DESIGNATION H	EACH	1.0
LIGHTING CONTROLLER, PEDESTAL MOUNTED, 240VOLT, 60AMP	EACH	1.0
LIGHT POLE, GALVANIZED STEEL, 50 FT. M.H., 6 FT. MAST ARM	EACH	1.0
DRILL EXISTING HANDHOLE	EACH	1.0
CIRCUIT BREAKER, 1-POLE, 20 AMP, 120V IN EXISTING TSC CABINET	EACH	1.0
REPLACEMENT OF SENSORS FOR ROADWAY WEATHER INFORMATION SYSTEM	L SUM	1.0
ROADWAY LIGHTING MODIFICATIONS	L SUM	1.0
UPGRADE RPU EQUIPMENT AND COMMUNICATIONS AT RWIS SITE	EACH	1.0
CLOSED CIRCUIT TELEVISION CAMERA EQUIPMENT	EACH	1.0
MISCELLANEOUS ELECTRICAL WORK	L SUM	1.0
CAT. 6 ETHERNET CABLE	FOOT	1268.0
CLOSED CIRCUIT TELEVISION DOME CAMERA, HD	EACH	5.0
CONDUIT ATTACHED TO STRUCTURE, 3/4" DIA., STAINLESS STEEL	FOOT	35.0
CONDUIT ATTACHED TO STRUCTURE, 1 1/2" DIA., STAINLESS STEEL	FOOT	125.0
JUNCTION BOX (SPECIAL)	EACH	2.0

CONSTRUCTION NOTES	
1.	EXISTING UTILITY LOCATION INFORMATION IS NOT SHOWN ON THE PLAN SHEETS. THE CONTRACTOR SHALL FIELD VERIFY THE LOCATION OF ALL UTILITIES AND PRIVATELY OWNED FACILITIES PRIOR TO THE INSTALLATION OF ANY COMPONENTS. THE CONTRACTOR SHALL VERIFY EXISTING
2.	THE LOCATION OF ALL UTILITIES AND PRIVATELY OWNED FACILITIES SHALL BE FIELD VERIFIED BY THE CONTRACTOR PRIOR TO THE INSTALLATION OF ANY COMPONENTS.
3.	THE CONTRACTOR SHALL BE RESPONSIBLE FOR LOCATING EXISTING IDOT ELECTRICAL FACILITIES AT HIS/HER OWN EXPENSE IF REQUIRED. THE CONTRACTOR SHALL ALSO BE LIABLE FOR ANY DAMAGE TO IDOT FACILITIES RESULTING FROM INACCURATE LOCATING.
4.	ELECTRICAL WORK SHALL CONFORM WITH NATIONAL, STATE, AND LOCAL CODES.
5.	THE CONTRACTOR SHALL PROVIDE ELECTRICAL CABLE SLACK IN ACCORDANCE WITH ARTICLE 873.03 UNLESS SPECIFIED OTHERWISE.
6.	ALL SURPLUS MATERIALS SHALL BE DISPOSED OF IN ACCORDANCE WITH ARTICLE 202.03 OF THE STANDARD SPECIFICATION.
7.	ANY MAINTENANCE OF EXISTING ELECTRICAL FACILITIES WILL BE CONSIDERED EXTRA WORK IN ACCORDANCE WITH ARTICLE 109.04 OF THE STANDARD SPECIFICATIONS.
8.	THE EXISTING LIGHTING AND CCTV CAMERAS SHALL REMAIN IN OPERATION DURING THE INSTALLATION OF THE PROPOSED COMPONENTS.
9.	THE CONTRACTOR SHALL FURNISH 3/4" DIAMETER SCHEDULE 40 PVC CONDUIT AND INSTALL IT ON THE EXISTING CATWALK RAILING. THE CONDUIT SHALL BE FIRMLY ATTACHED WITH ATTACHMENT SPACING NOT TO EXCEED EVERY SIX FEET. THE CONTRACTOR SHALL FURNISH AND INSTALL NON-METALLIC SEALTITE TO ACCOMODATE MOVEMENT FROM EXPANSION AND DEFLECTION AND PREVENT DAMAGE TO THE CONDUIT. CONDUIT SHALL BE INSTALLED IN ACCORDANCE WITH SECTION 811 OF THE STANDARD SPECIFICATIONS. THIS WORK WILL BE PAID FOR AS "UNDERGROUND CONDUIT, PVC, 3/4" DIA."
10.	THE CONTRACTOR SHALL FURNISH 1-1/2" DIAMETER SCHEDULE 40 PVC CONDUIT AND INSTALL IT ON THE EXISTING CATWALK RAILING AT THE LOCATIONS INDICATED ON THE PLAN SHEETS. THE CONDUIT SHALL BE FIRMLY ATTACHED WITH ATTACHMENT SPACING NOT TO EXCEED EVERY SIX FEET. THE CONTRACTOR SHALL FURNISH AND INSTALL NON-METALLIC SEALTITE TO ACCOMODATE MOVEMENT FROM EXPANSION AND DEFLECTION AND PREVENT DAMAGE TO THE CONDUIT. CONDUIT SHALL BE INSTALLED IN ACCORDANCE WITH SECTION 811 OF THE STANDARD SPECIFICATIONS. THIS WORK WILL BE PAID FOR AS "UNDERGROUND CONDUIT, PVC, 1-1/2" DIA."
11.	CAT 6 ETHERNET CABLE RUNS SHALL NOT EXCEED 300 FT. TO ENSURE FUNCTIONALITY.
12.	ALL METALLIC STRUCTURES, CONDUITS, AND JUNCTION BOXES SHALL BE GROUNDED AND SAFETY BONDED IN ACCORDANCE WITH NEC REQUIREMENTS
13.	THE CONTRACTOR SHALL FURNISH AND INSTALL LIGHT POLE PROTECTION SLEEVES ON ALL EXISTING AND PROPOSED LIGHT POLES TO PROVIDE PROTECTION FROM SNOW PLOW BADE IMPACTS. THE COST OF THIS WORK SHALL BE INCLUDED IN THE PAY ITEM "ROADWAY LIGHTING MODIFICATIONS".
14.	THE CONTRACTOR SHALL FURNISH AND TEMPORARY CONDUITS, JUNCTION BOXES, WIRING, AND ALL OTHER ITEMS REQUIRED TO PROVIDE TEMPORARY SERVICE FOR THE OVERHEAD LIGHTING AND RWIS DURING THE REPLACEMENT OF THE BRIDGE BEARINGS ON THE EAST ABUTMENT. THE COST OF THIS WORK SHALL BE INCLUDED IN THE PAY ITEM "MISCELLANEOUS ELECTRICAL WORK".

NOT TO SCALE  
ELECTRICAL SHEET 1 OF 10

FILE NAME =	USER NAME = howalder	DESIGNED -	REVISED -	<b>STATE OF ILLINOIS DEPARTMENT OF TRANSPORTATION</b>	<b>SCHEDULE OF QUANTITES FOR PROPOSED ELECTRICAL WORK AND CONSTRUCTION NOTES</b>	F.A.P. RTE.	SECTION	COUNTY	TOTAL SHEETS	SHEET NO.
D:\common\GEN\Transfer - bureaus\68E79	- Final Plans\68E79 - Pekin Bridge Lighting, DRAWN ITS (Revised 2-10-20).dgn	CHECKED -	REVISED -			693	(12B)BR,BDR,BJR	TAZEWELL	63	46
	PLOT SCALE = 38.0568' / in.	DATE -	REVISED -			CONTRACT NO. 68E79				
	PLOT DATE = 2/10/2020					ILLINOIS FED. AID PROJECT				



INSTALL CAT 6 ETHERNET CABLE FROM EX. CCTV CABINET TO CAMERA 1 (TOTAL CABLE LENGTH NOT TO EXCEED 300 FT.)

INSTALL CAT 6 ETHERNET CABLE FROM EX. CCTV CABINET TO CAM 2 POWER SUPPLY IN JB 1 DISTANCE NOT TO EXCEED 300 FT.

INSTALL 6 FT. OF SLACK CABLE IN PROP. JUNCTION BOXES

INSTALL #6 1/2 X 3 FROM EX. CCTV CABINET TO JB 1  
INSTALL POWER SUPPLY FOR CAM 2 INSIDE JB 1 AND CONNECT TO 120V

UNDRGRD C PVC 1-1/2  
40.0 FT. (ATTACH CONDUIT TO CATWALK RAILING)

CON AT ST 1.5 SS  
50.0 FT.

JUN BX SS AS 12X12X6  
1.0 EACH

UNDRGRD C PVC 3/4  
125.0 FT. (ATTACH CONDUIT TO CATWALK RAILING)

EX. CATWALK

JB 1

CAM 1

JUNCTION BOX SPL  
1.0 EACH (12"X12"X6" PVC ATTACHED TO CATWALK)

CCTV DOME CAMERA HD  
1.0 EACH (INSTALL CAMERA ON PENDANT MOUNT 1.0 FT. BELOW STRUCTURE - SEE DETAIL ON ELECTRICAL PLAN SHEET 2)

IL 9 (MCNAUGHTON BRIDGE)

CCTV DOME CAMERA HD  
1.0 EACH (REMOVE EX. CAMERA AND INSTALL PROP. CAMERA ON EX. LIGHT POLE)

DRILL EX HANDHOLE  
1.0 EACH

CAT 6 ETHERNET CABLE  
205.0 FT. (INSTALL FROM EX. CCTV CABINET LOCATED ON LIGHT POLE TO PROP. CCTV CAMERA)

CON AT ST 1.5 SS  
75.0 FT.

JUN BX SS AS 12X12X6  
1.0 EACH

UNDRGRD C PVC 1-1/2  
90.0 FT.

EX. ALUM DAVIT POLE

CB 1P 20A/120V EX CAB  
1.0 EACH (INSTALL IN EX. CCTV CABINET)

FRONT ST.

BILL OF MATERIALS - PEKIN BRIDGE ELECTRICAL PLAN SHEET 2

ITEM DESCRIPTION	UNIT	TOTAL QTY.
JUNCTION BOX, STAINLESS STEEL, ATTACHED TO STRUCTURE, 12" X 12" X 6"	EACH	2.0
DRILL EXISTING HANDHOLE	EACH	1.0
CIRCUIT BREAKER, 1-POLE, 20 AMP, 120V IN EXISTING TSC CABINET	EACH	1.0
UNDERGROUND CONDUIT, PVC, 3/4" DIA.	FOOT	125.0
UNDERGROUND CONDUIT, PVC, 1 1/2" DIA.	FOOT	130.0
CAT. 6 ETHERNET CABLE	FOOT	732.0
CLOSED CIRCUIT TELEVISION DOME CAMERA, HD	EACH	2.0
CONDUIT ATTACHED TO STRUCTURE, 1 1/2" DIA., STAINLESS STEEL	FOOT	125.0
JUNCTION BOX (SPECIAL)	EACH	1.0

NOT TO SCALE  
ELECTRICAL SHEET 2 OF 10

FILE NAME =	USER NAME = howalder	DESIGNED -	REVISED -
\\Central\4\common\GEN\Transfer - bureau\68E79 - Final Plans\68E79 - Pekin Bridge		DRAWING, RWIS, and ITS (Final 12-10-19).dgn	REVISED -
	PLOT SCALE = 38.0588 1 / in.	CHECKED -	REVISED -
	PLOT DATE = 12/12/2019	DATE -	REVISED -

STATE OF ILLINOIS  
DEPARTMENT OF TRANSPORTATION

PROPOSED CCTV CAMERA AND LIGHTING CONTROLLER UPGRADES  
PEKIN BRIDGE - PEORIA COUNTY

F.A.P. RTE.	SECTION	COUNTY	TOTAL SHEETS	SHEET NO.
693	(12B)BR,BDR,BJR	TAZEWELL	63	47
CONTRACT NO. 68E79				
ILLINOIS FED. AID PROJECT				

SCALE: TO STA.

**INSTALL 6 FT. OF SLACK  
CABLE IN PROP. JUNCTION BOXES**

**JUNCTION BOX SPL  
1.0 EACH (6" X 6" PVC ATTACHED  
TO CATWALK RAILING)  
INSTALL 6 FT. OF SLACK  
CABLE IN PROP. JUNCTION BOX**

**CAT 6 ETHERNET CABLE  
300.0 FT. (INSTALL FROM PROP.  
JUNCTION BOX**

**UNDRGRD C PVC 3/4  
300.0 FT. (ATTACH CONDUIT  
TO CATWALK RAILING)**

**UNDRGRD C PVC 3/4  
175.0 FT. (ATTACH CONDUIT  
TO CATWALK RAILING)**

**EX. CATWALK**

**CAMERA INSTALLATION DETAIL  
PENDANT MOUNTING**

**RIGID  
ATTACHMENT  
POINTS**

**GALVANIZED  
UNI-STRUT  
OR STEEL PLATE  
ATTACHED TO  
CATWALK**

**1.5" DIA. GSC  
10' LENGTH**

**AXIS T-94A01D  
PENDANT KIT**

**AXIS Q-6055E  
DOME CAMERA**

**IL 9 (MCNAUGHTON BRIDGE)**

**Pekin Bridge**

**Margaret St**

**CCTV CAMERA EQUIPMENT  
1.0 EACH (INSTALL AXIS T8129-E  
POE EXTENDER INSIDE PROP.  
JUNCTION BOX DISTANCE NOT TO  
EXCEED 300 FT FROM POWER  
SUPPLY IN JB 1**

**CAT 6 ETHERNET CABLE  
175.0 FT. (INSTALL FROM CAMERA  
POWER SUPPLY IN JB 1 TO JB 2**

**CCTV DOME CAMERA HD  
1.0 EACH (INSTALL CAMERA  
ON PENDANT MOUNT BELOW  
STRUCTURE TO VIEW RIVER  
CHANNEL)**

**THE CONTRACTOR SHALL FURNISH AND INSTALL  
A RIGID CAMERA MOUNTING BRACKET FOR  
BOTH PENDANT MOUNTED CAMERAS. ALL  
COMPONENTS SHALL BE GALVANIZED STEEL.  
THE COST OF THIS WORK SHALL BE INCLUDED  
IN THE COST OF THE CAMERA.**

**BILL OF MATERIALS - PEKIN BRIDGE ELECTRICAL PLAN SHEET 3**

ITEM DESCRIPTION	UNIT	TOTAL QTY.
CAT. 6 ETHERNET CABLE	FOOT	491.0
CLOSED CIRCUIT TELEVISION CAMERA EQUIPMENT	EACH	1.0
UNDERGROUND CONDUIT, PVC, 3/4" DIA.	FOOT	475.0
CLOSED CIRCUIT TELEVISION DOME CAMERA, HD	EACH	1.0
JUNCTION BOX (SPECIAL)	EACH	1.0

**NOT TO SCALE  
ELECTRICAL SHEET 3 OF 10**

FILE NAME =	USER NAME = howalder	DESIGNED -	REVISED -
\\Central\4\common\GEN\Transfer - bureau\68E79 - Final Plans\68E79 - Pekin Bridge		DRAWING, RWIS, and ITS (Final 12-10-19).dgn	REVISED -
	PLOT SCALE = 38.0588 ' / in.	CHECKED -	REVISED -
	PLOT DATE = 12/12/2019	DATE -	REVISED -

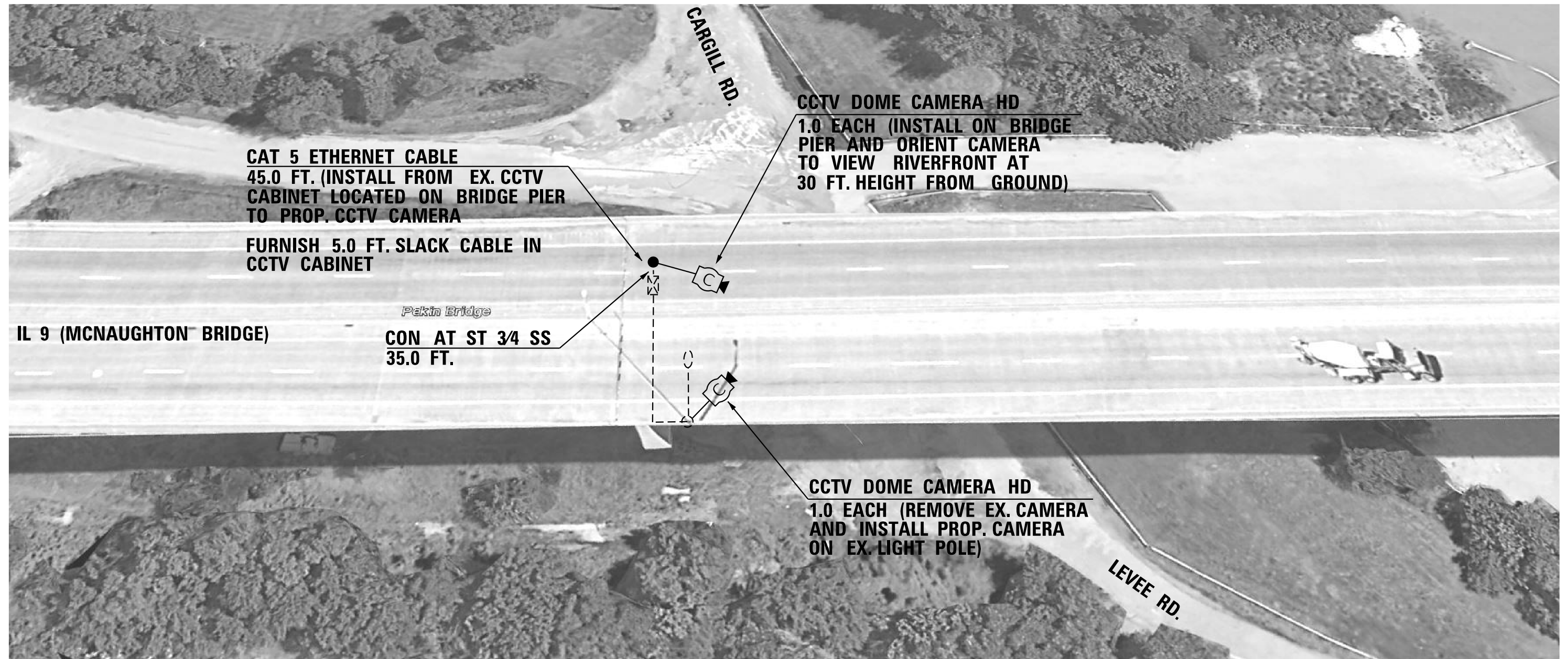
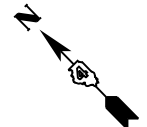
**STATE OF ILLINOIS  
DEPARTMENT OF TRANSPORTATION**

**PROPOSED CCTV CAMERA AND LIGHTING CONTROLLER UPGRADES  
PEKIN BRIDGE - PEORIA COUNTY**

SCALE: STA. TO STA.

F.A.P. RTE.	SECTION	COUNTY	TOTAL SHEETS	SHEET NO.
693	(12B)BR,BDR,BJR	TAZEWELL	63	48
CONTRACT NO. 68E79				
ILLINOIS FED. AID PROJECT				



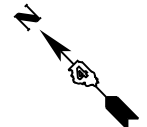


**BILL OF MATERIALS - PEKIN BRIDGE ELECTRICAL PLAN SHEET 4**

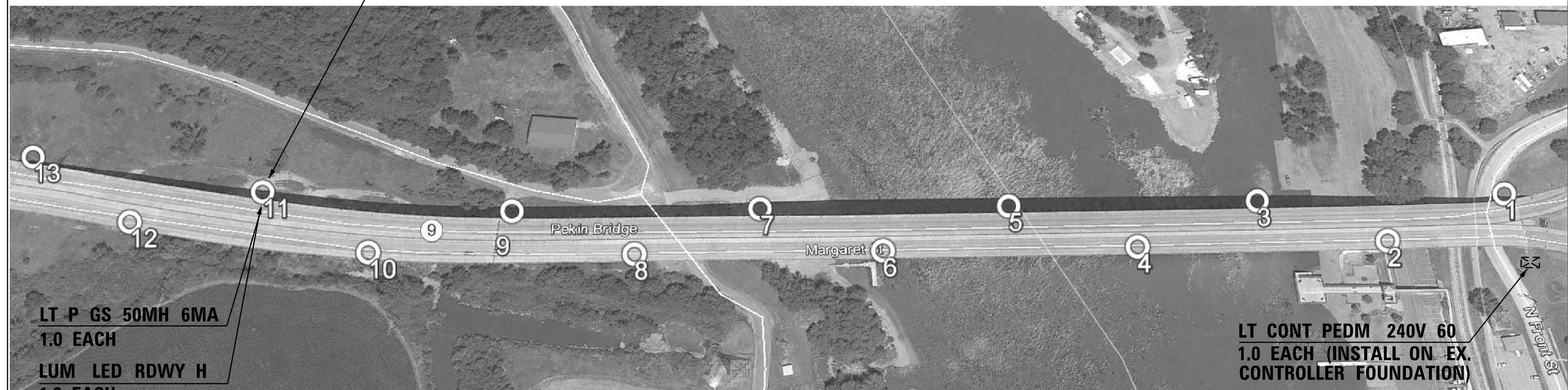
ITEM DESCRIPTION	UNIT	TOTAL QTY.
CAT. 6 ETHERNET CABLE	FOOT	45.0
CLOSED CIRCUIT TELEVISION DOME CAMERA, HD	EACH	2.0
CONDUIT ATTACHED TO STRUCTURE, 3/4" DIA. STAINLESS STEEL	FOOT	35.0

**NOT TO SCALE  
ELECTRICAL SHEET 4 OF 10**

FILE NAME =	USER NAME = howalder	DESIGNED -	REVISED -	<b>STATE OF ILLINOIS DEPARTMENT OF TRANSPORTATION</b>	<b>PROPOSED CCTV CAMERA UPGRADES PEKIN BRIDGE - TAZEWELL COUNTY</b>	F.A.P. RTE.	SECTION	COUNTY	TOTAL SHEETS	SHEET NO.
\\Central\4\common\GEN\Transfer - bureau\68E79 - Final Plans\68E79 - Pekin Bridge	DRAWING, RWIS, and ITS (Final 12-10-19).dgn	REVIS	REVIS			693	(12B)BR,BDR,BJR	TAZEWELL	63	49
PLOT SCALE = 38.0588' / in.	CHECKED -	REVIS	REVIS			CONTRACT NO. 68E79				
PLOT DATE = 12/12/2019	DATE -	REVIS	REVIS			ILLINOIS FED. AID PROJECT				



**REPLACE LIGHT POLE ANCHOR BOLTS  
(SEE STRUCTURE PLANS FOR DETAILS)**



**LT P GS 50MH 6MA  
1.0 EACH  
LUM LED RDWY H  
1.0 EACH**

**LT CONT PEDM 240V 60  
1.0 EACH (INSTALL ON EX.  
CONTROLLER FOUNDATION)**

**THE CONTRACTOR SHALL FURNISH AND INSTALL LIGHT POLE PROTECTION SLEEVES ON ALL EXISTING AND PROPOSED LIGHT POLES TO PROVIDE PROTECTION FROM SNOW PLOW BLADE IMPACTS. THIS COST OF THIS WORK SHALL BE INCLUDED IN THE COST OF "ROADWAY LIGHTING MODIFICATIONS". REFER TO ELECTRICAL SHEET 10 FOR DETAILS.**

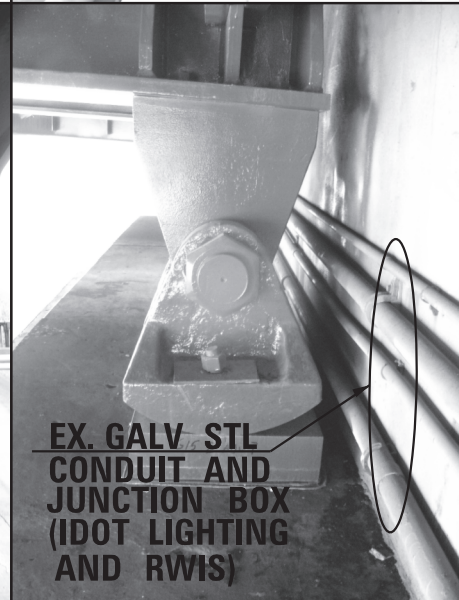
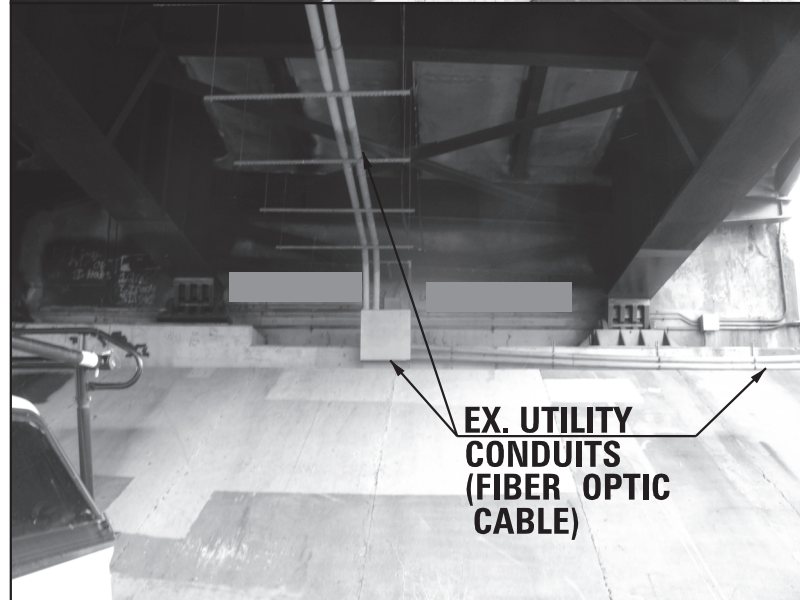
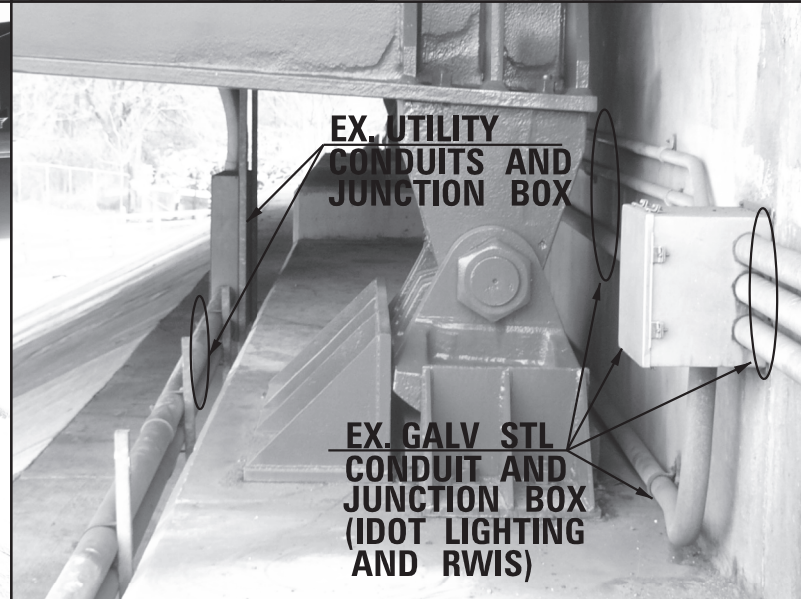
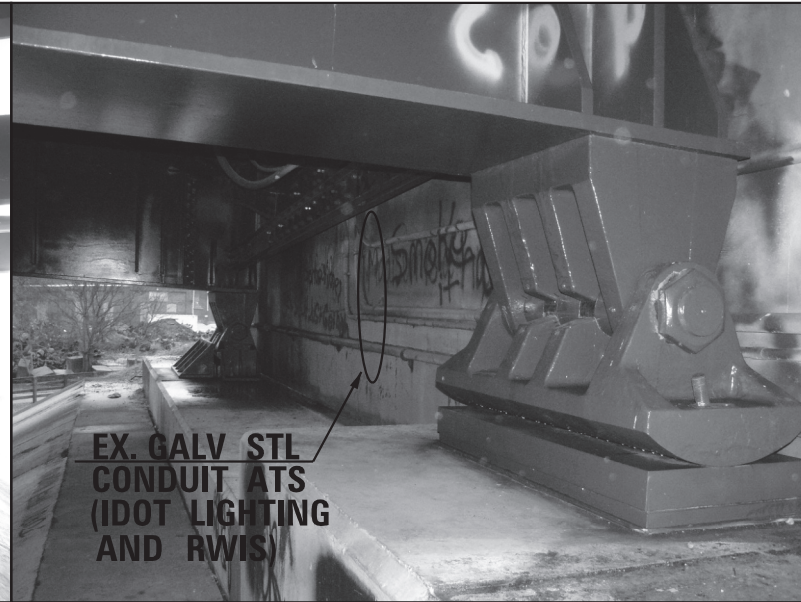
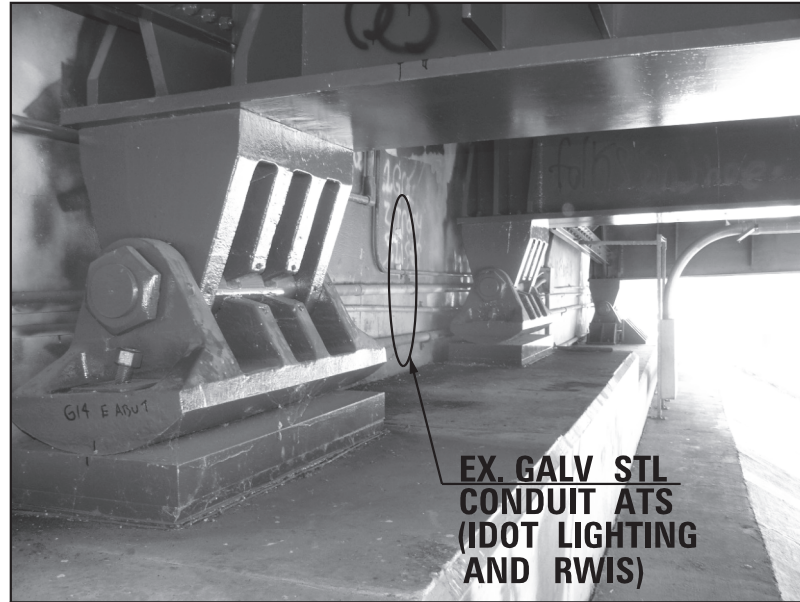
BILL OF MATERIALS - PEKIN BRIDGE ELECTRICAL PLAN SHEET 5		
ITEM DESCRIPTION	UNIT	TOTAL QTY.
LUMINAIRE, LED, ROADWAY, OUTPUT DESIGNATION H	EACH	1.0
LIGHTING CONTROLLER, PEDESTAL MOUNTED, 240VOLT, 60AMP	EACH	1.0
LIGHT POLE, GALVANIZED STEEL, 50 FT. M.H., 6 FT. MAST ARM	EACH	1.0
ROADWAY LIGHTING MODIFICATIONS	L SUM	1.0

**NOT TO SCALE  
ELECTRICAL SHEET 5 OF 10**

FILE NAME =	USER NAME = howalder	DESIGNED -	REVISED -	<b>STATE OF ILLINOIS DEPARTMENT OF TRANSPORTATION</b>	<b>PROPOSED OVERHEAD LIGHTING IMPROVEMENTS PEKIN BRIDGE</b>	F.A.P. RTE.	SECTION	COUNTY	TOTAL SHEETS	SHEET NO.	
D:\common\GEN\Transfer - bureaus\68E79	- Final Plans\68E79 - Pekin Bridge Lighting, DRAWN ITS (Revised 2-10-20).dgn	REVISOR	DATE			693	(12B)BR,BDR,BJR	TAZEWELL	63	50	
	PLOT SCALE = 38.0568' / in.	CHECKED -	REVISOR -			CONTRACT NO. 68E79					
	PLOT DATE = 2/10/2020	DATE -	REVISOR -			ILLINOIS FED. AID PROJECT					



**EXISTING CONDUITS ATTACHED TO EAST ABUTMENT (TAZEWELL COUNTY)**



THE CONTRACTOR SHALL FURNISH AND INSTALL TEMPORARY CONDUIT, SEAL TITE, JUNCTION BOXES, WIRING, AND ALL OTHER ITEMS REQUIRED TO TEMPORARILY RELOCATE THE WIRING FOR THE IDOT BRIDGE LIGHTING AND RWIS FACILITIES PRIOR TO BRIDGE BEARING REPLACEMENT. THE CONTRACTOR SHALL INSTALL SCHEDULE 80 PVC CONDUIT AND ASSOCIATED WIRING ALONG THE BACK OF THE ABUTMENT CAP TO FACILITATE THE INSTALLATION OF THE PROPOSED CONCRETE PEDESTALS (BRIDGE SEATS) AND POT BEARINGS. THE CONTRACTOR SHALL INSTALL TEMPORARY ELECTRICAL CABLING AS REQUIRED TO MAINTAIN OVERHEAD LIGHTING AND RWIS OPERATION. ALL TEMPORARY SPLICES SHALL BE ENCLOSED IN WEATHERPROOF PVC JUNCTION BOXES AND ALL WORK SHALL CONFORM TO NEC REQUIREMENTS. PRIOR TO COMMENCING WORK, THE CONTRACTOR SHALL INVENTORY THE CONDUITS AND CONDUCTORS TO DETERMINE THE OPTIMUM METHOD TO INSTALL TEMPORARY FACILITIES. THE CONTRACTOR SHALL FURNISH SLACK CABLE AS NEEDED TO ACCOMODATE THE PROPOSED BEARING REPLACEMENT WORK. THE TEMPORARY FACILITIES WILL REMAIN IN USE UNTIL THE BEARING REPLACEMENT HAS BEEN COMPLETED FOR THE ENTIRE ABUTMENT. THE CONTRACTOR SHALL OBTAIN LOCATION VERIFICATION FROM THE RESIDENT ENGINEER PRIOR TO COMMENCING WORK TO ENSURE THAT THE TEMPORARY CONDUIT, JUNCTION BOXES, AND WIRING WILL NOT INTERFERE WITH THE PROPOSED BRIDGE CONSTRUCTION. THE COST OF THIS WORK SHALL BE INCLUDED IN THE PAY ITEM FOR "MISCELLANEOUS ELECTRICAL WORK".

IN THE EVENT THAT THE EXISTING UTILITY CONDUITS AND JUNCTION BOXES (CONTAINS FIBER OPTIC CABLES) ARE IN CONFLICT WITH THE PROPOSED BRIDGE BEARING REPLACEMENT, THE CONTRACTOR SHALL PROVIDE PROTECTION FOR THE THESE FACILITIES AND TEMPORARILY REPOSITION OR RELOCATE THEM AS DIRECTED BY THE RESIDENT ENGINEER TO ACCOMMODATE THE PROPOSED BRIDGE CONSTRUCTION. THIS WORK WILL BE CONSIDERED EXTRA WORK IN ACCORDANCE WITH ARTICLE 109.04 OF THE STANDARD SPECIFICATIONS (PAYMENT FOR EXTRA WORK).

UPON COMPLETION OF THE BEARING REPLACEMENT WORK ALONG THE ENTIRE ABUTMENT, THE CONTRACTOR SHALL INSTALL THE PERMANENT CONDUITS AND JUNCTION BOXES ALONG THE BACK WALL AND SIDES OF THE ABUTMENT AS REQUIRED TO RESTORE OPERATION OF THE IDOT OVERHEAD LIGHTING AND RWIS FACILITIES. THE CONTRACTOR SHALL WORK WITH THE DEPARTMENT TO DETERMINE THE OPTIMUM CONDUIT LAYOUT FOR THE PERMANENT FACILITIES AND INSTALL THE PROPOSED ITEMS IN THE LOCATIONS AS DIRECTED BY THE RESIDENT ENGINEER. THE COST OF THIS WORK WILL BE PAID FOR SEPARATELY UNDER THE ASSOCIATED PAY ITEMS FOR THE STAINLESS STEEL CONDUIT AND JUNCTION BOXES.

THE CONTRACTOR SHALL FURNISH AND INSTALL NON-METALLIC SEAL TIGHT, EXPANSION AND DEFLECTION COUPLINGS, BRACKETS, HARDWARE, AND ALL OTHER ITEMS REQUIRED FOR THE INSTALLATION OF THE PROPOSED STAINLESS STEEL CONDUIT AND JUNCTION BOXES. THE COST OF THESE ITEMS SHALL BE INCLUDED IN THE COST OF THE PROPOSED STAINLESS STEEL CONDUIT AND JUNCTION BOXES.

UPON INSTALLATION OF THE PERMANENT CONDUIT AND JUNCTION BOXES, THE CONTRACTOR SHALL INSTALL NEW ELECTRIC CABLES AND SPLICE THE PROPOSED CABLES INTO THE EXISTING CIRCUITS AS REQUIRED TO RESTORE FUNCTIONALITY. ALL SPLICES SHALL BE WEATHERPROOF AND MADE INSIDE THE PROPOSED STAINLESS STEEL JUNCTION BOXES. ALL METALLIC COMPONENTS SHALL BE GROUNDED AND ALL WORK SHALL BE IN ACCORDANCE WITH NEC REQUIREMENTS. ELECTRIC CABLING WILL BE PAID FOR IN ACCORDANCE WITH ARTICLE 109.04 OF THE STANDARD SPECIFICATIONS (PAYMENT FOR EXTRA WORK).

REFER TO STRUCTURE PLAN SHEETS FOR ADDITIONAL INFORMATION IN REGARDS TO THE PROPOSED BRIDGE BEARING REPLACEMENT ON THE EAST ABUTMENT.

BILL OF MATERIALS - PEKIN BRIDGE ELECTRICAL PLAN SHEET 6		
ITEM DESCRIPTION	UNIT	TOTAL QTY.
CONDUIT ATTACHED TO STRUCTURE, 2" DIA., STAINLESS STEEL	FOOT	300.0
JUNCTION BOX, STAINLESS STEEL, ATTACHED TO STRUCTURE, 12" X 12" X 8"	EACH	2.0
MISCELLANEOUS ELECTRICAL WORK	L SUM	1.0

**NOT TO SCALE  
ELECTRICAL SHEET 6 OF 10**

FILE NAME =	USER NAME = howlader	DESIGNED -	REVISED -
D:\common\GEN\Transfer - bureaus\68E79	- Final Plans\68E79 - Pekin Bridge Lighting, DRAWN ITS (Revised 2-10-20).dgn		REVISED -
	PLOT SCALE = 38.0568' / in.	CHECKED -	REVISED -
	PLOT DATE = 2/10/2020	DATE -	REVISED -

**STATE OF ILLINOIS  
DEPARTMENT OF TRANSPORTATION**

<b>PROPOSED CONDUIT ATTACHED TO EAST ABUTMENT</b>		F.A.P. RTE.	SECTION	COUNTY	TOTAL SHEETS	SHEET NO.
<b>IL 9 - MCNAUGHTON BRIDGE (PEKIN)</b>		693	(12B)BR,BDR,BJR	TAZEWELL	63	51
SCALE:		STA.	TO STA.	CONTRACT NO. 68E79		

ILLINOIS FED. AID PROJECT



Bench Mark Location  
Top of NE Abutment of  
Railroad Bridge over  
Illinois River - Elev. 459.24

**CURVE DATA**

P.I. Sta.	85+41.91
P.C. Sta.	84+00.12
P.T. Sta.	88+21.52
$\Delta$	9°-49'-23.1"
D	1°-48'
M	3274.04'
T	281.59'
L	561.40'
S.E.	.051/ft.

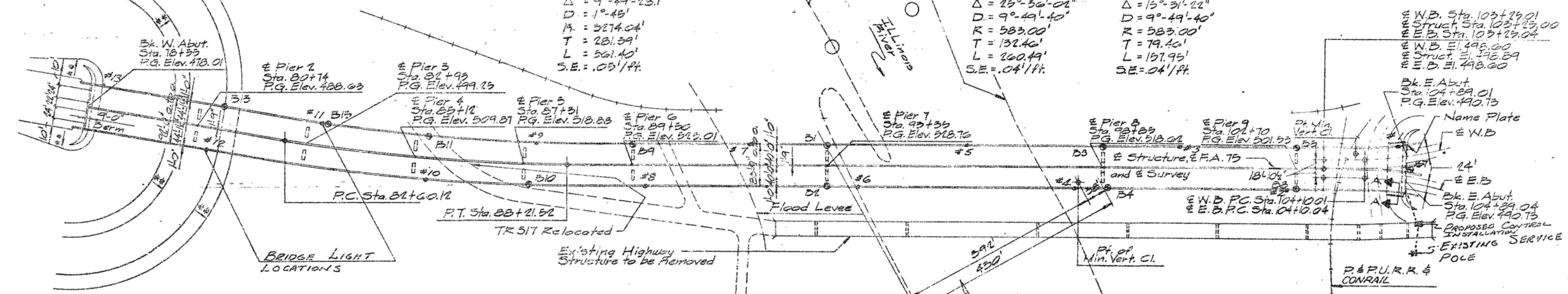
**WESTBOUND CURVE DATA**

P.I. Sta.	108+42.47
P.C. Sta.	104+10.01
P.T. Sta.	104+10.90
$\Delta$	25°-30'-01"
D	9°-49'-40"
R	583.00'
T	132.46'
L	260.44'
S.E.	.041/ft.

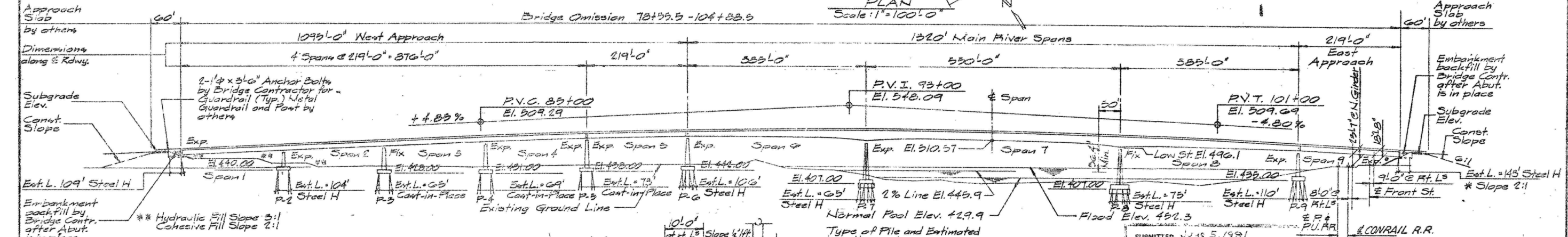
**EASTBOUND CURVE DATA**

P.I. Sta.	104+89.50
P.C. Sta.	104+10.04
P.T. Sta.	109+01.99
$\Delta$	15°-31'-22"
D	9°-49'-40"
R	583.00'
T	79.46'
L	157.95'
S.E.	.041/ft.

ROUTE NO.	SECTION	COUNTY	TOTAL SHEETS	SHEET NO.
F.A. 693	12L	PEORIA-TAZEWELL	9	8
FED. ROAD DIV. NO.	ILLINOIS	PROJECT		



PLAN  
Scale: 1"=100'-0"



PROFILE-ROUTE ILL-9

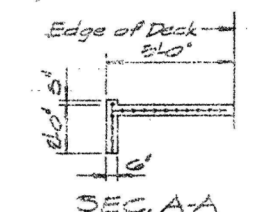
**DESIGN LOADS**  
Live Load HS20-44  
Future W.S. = 25 pcf

**DESIGN STRESSES**  
f<sub>y</sub> = 60,000 psi (Reinforcement-Substructure, Deck, Curbs, Parapet & Median)  
f<sub>s</sub> = 27,000 psi (Structural Steel N-222 - Unpainted) 1/2" to 4" Thickness Inclusive (Except for Bearings and Pins)  
f<sub>c</sub> = 3500 psi (Substructure, Deck, Curbs, Parapet & Median)

**Waterway Information**  
Drainage Area 14,000 sq. miles TTN  
8(100) 87,000 cfs PTE 4PM  
Opening (Req'd.) 22,300 sq. ft.  
Opening (Proposed) 21,570 sq. ft.\*  
Q(50) 78,000 cfs +  
\* Controlled by other than hydraulic considerations.  
+ Below HW Elev. 455.2

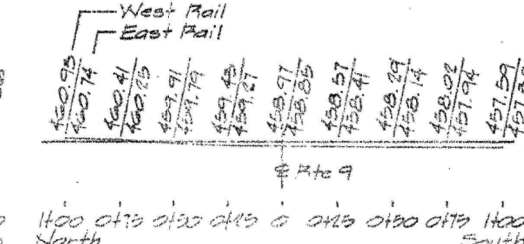
FOR INFORMATION ONLY

SECTION THRU EAST SLOPEWALL



SEC. A-A

PROFILE-FRONT STREET



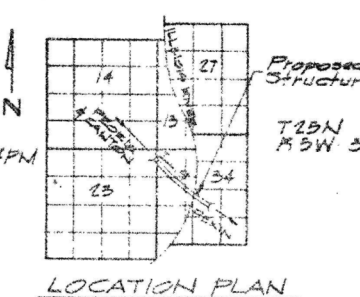
PROFILE-RAILROAD

PROFILE-CONRAIL RAILROAD

SUBMITTED June 5, 1981  
APPROVED  
DATE 6-5-81



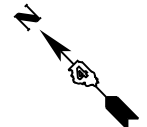
STATION 96+50  
BUILT BY  
STATE OF ILLINOIS  
F.A. PROJ. DR. F-693(15)  
LOADING HS10  
NAME PLATE  
(See Sht. 815)



LOCATION PLAN

STATE OF ILLINOIS  
DEPARTMENT OF TRANSPORTATION  
GENERAL PLAN & ELEVATION  
PROJECT: F-156  
ILL. 9 over ILLINOIS RIVER  
F.A. 693 SECTION 12L  
PEORIA-TAZEWELL COUNTIES  
STA. 96+50

THE ENGINEERS COLLABORATIVE  
CHICAGO, ILLINOIS  
NOT TO SCALE  
ELECTRICAL SHEET 7 OF 10



THE CONTRACTOR SHALL FURNISH AND INSTALL STAINLESS STEEL CONDUIT AND JUNCTION BOXES AS REQUIRED TO CONNECT PAVEMENT SENSORS TO PROPOSED RWIS CONTROL CABINET

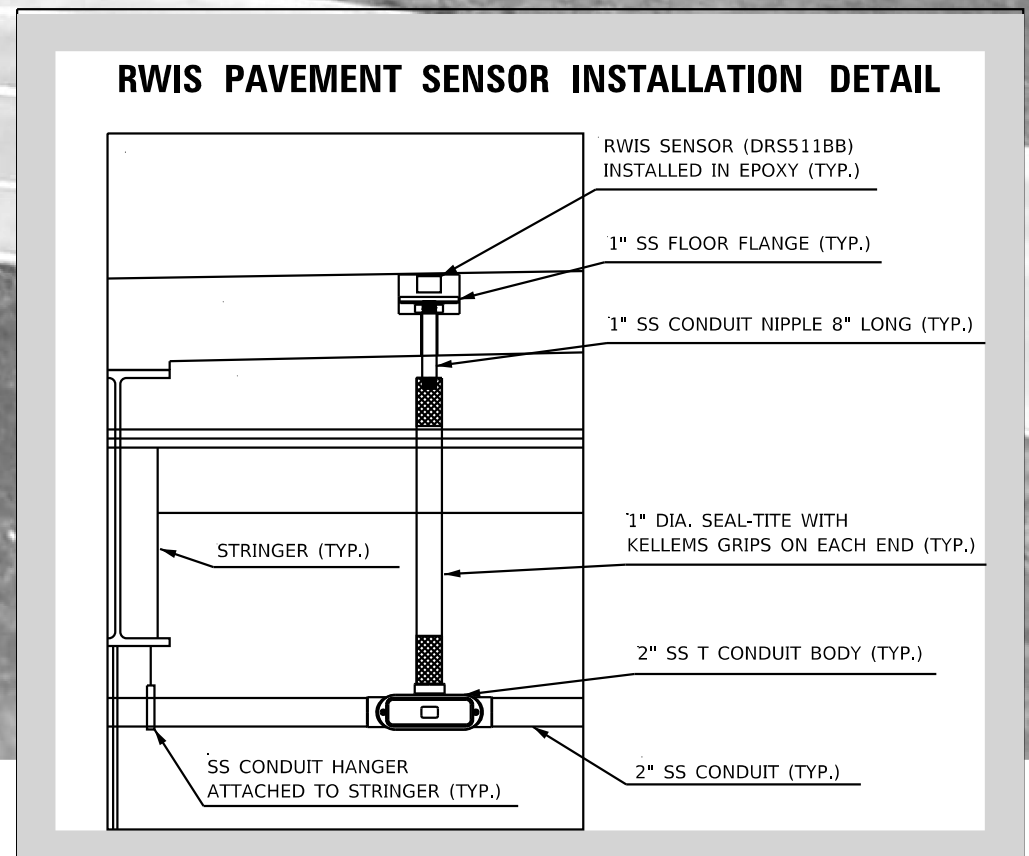
THE CONTRACTOR WILL BE RESPONSIBLE FOR DETERMINING CONDUIT ROUTING AND JUNCTION BOX PLACEMENT. REFER TO SPECIAL PROVISION FOR ADDITIONAL DETAILS

ALL HOLES IN BRIDGE DECK SHALL BE CORE DRILLED TO ACCOMODATE PROPOSED RWIS SENSORS

UP RPU EQ COM RWISS  
1.0 EACH

IL 9 (MCNAUGHTON BRIDGE)

REPLCMT SENSORS RWIS  
1.0 LUMP SUM (INCLUDES SENSORS, CONDUIT, FITTINGS, WIRING, ETC. – SEE PROJECT SPECIAL PROVISIONS FOR ADDITIONAL INFORMATION)



BILL OF MATERIALS - PEKIN BRIDGE ELECTRICAL PLAN SHEET 8

ITEM DESCRIPTION	UNIT	TOTAL QTY.
REPLACEMENT OF SENSORS FOR ROADWAY WEATHER INFORMATION SYSTEM	L SUM	1.0
UPGRADE RPU EQUIPMENT AND COMMUNICATIONS AT RWIS SITE	EACH	1.0

STATE OF ILLINOIS  
DEPARTMENT OF TRANSPORTATION

PROPOSED RWIS IMPROVEMENTS  
PEKIN BRIDGE – PEORIA COUNTY

F.A.P. RTE.	SECTION	COUNTY	TOTAL SHEETS	SHEET NO.
693	(12B)BR,BDR,BJR	TAZEWELL	63	53

CONTRACT NO. 68E79

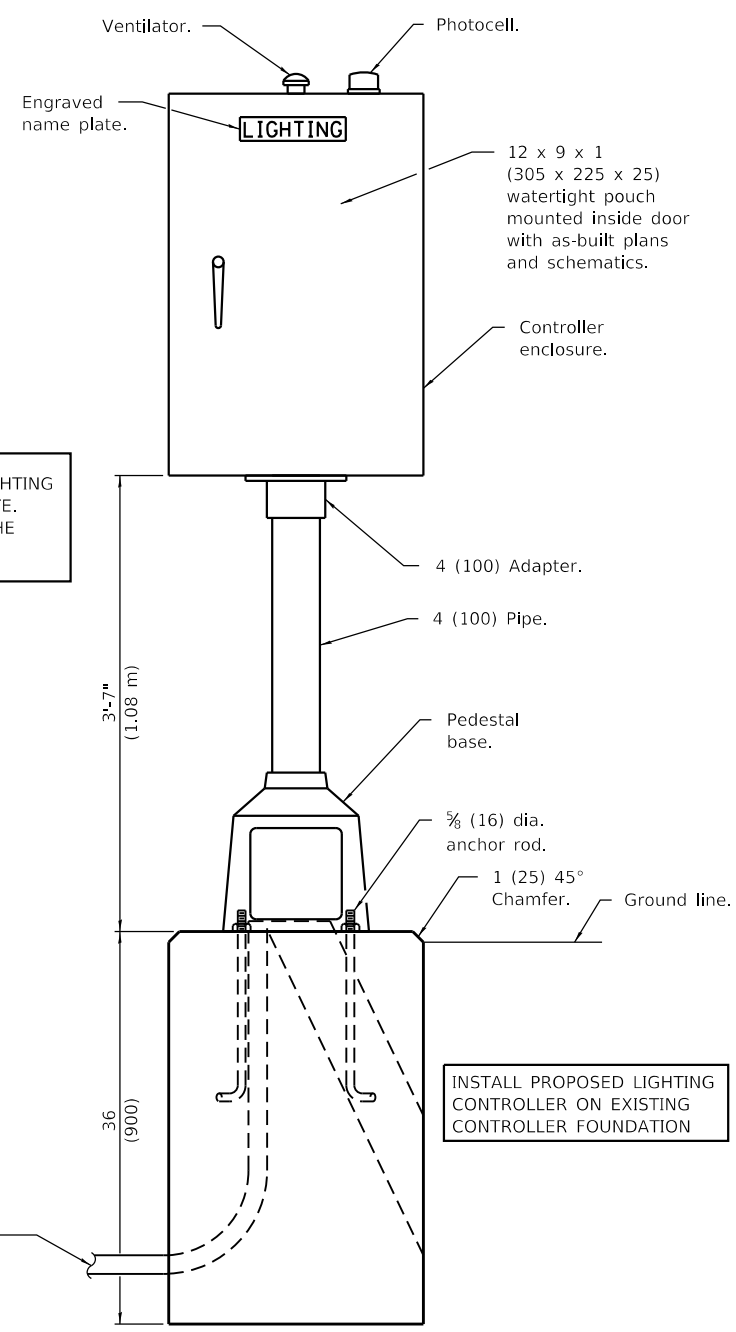
FILE NAME =	USER NAME = howalder	DESIGNED -	REVISED -
\\Central\4\common\GEN\Transfer - bureau\68E79 - Final Plans\68E79 - Pekin Bridge		DRAWING, RWIS, and ITS (Final 12-10-19).dgn	REVISED -
	PLOT SCALE = 38.0588 ' / in.	CHECKED -	REVISED -
	PLOT DATE = 12/12/2019	DATE -	REVISED -

SCALE: STA. TO STA.

NOT TO SCALE  
ELECTRICAL SHEET 8 OF 10

ILLINOIS FED. AID PROJECT





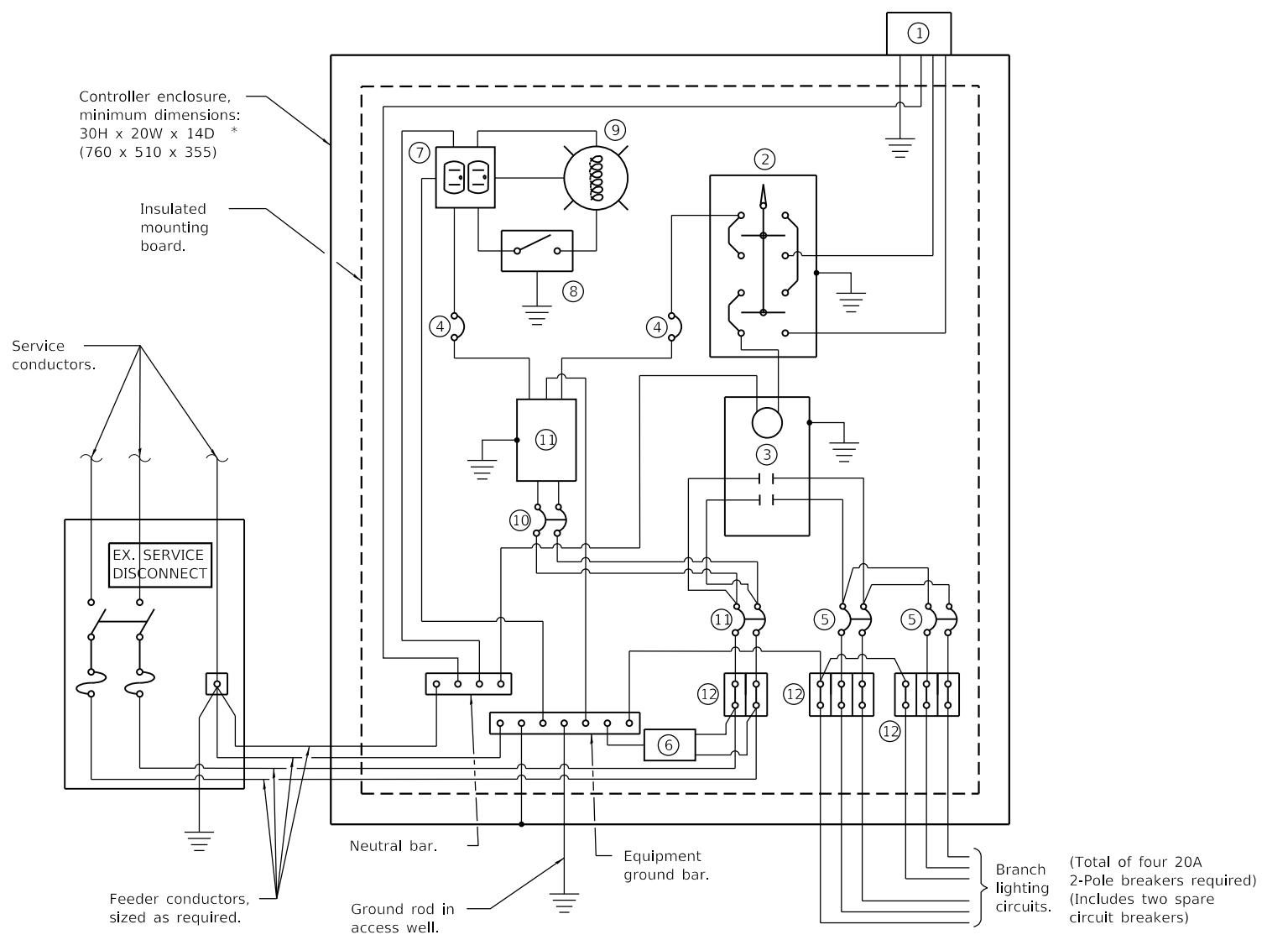
THE CONTRACTOR SHALL REMOVE THE EXISTING LIGHTING CONTROLLER AND DISPOSE OF IT FROM THE JOB SITE. THE COST OF THIS WORK SHALL BE INCLUDED IN THE COST OF THE PROPOSED LIGHTING CONTROLLER

INSTALL PROPOSED LIGHTING CONTROLLER ON EXISTING CONTROLLER FOUNDATION

To service pole.

**THE PROPOSED LIGHTING CONTROLLER WILL BE INSTALLED ON THE EXISTING CONTROLLER FOUNDATION**

**THE EXISTING SERVICE INSTALLATION WILL REMAIN IS USE WITH THE PROPOSED LIGHTING CONTROLLER**



**CONTROL SCHEMATIC**

- ① Photocell with integral surge arrester.
- ② HAND-OFF-AUTO selector switch.
- ③ 60 amp, electrically held contactor.
- ④ 15 amp, 1-pole circuit breaker.
- ⑤ 20 amp\*, 2-pole circuit breaker (two spares required but not shown).
- ⑥ Surge arrester.
- ⑦ GFCI duplex receptacle.
- ⑧ Single-pole, single-throw switch.
- ⑨ Light Fixture, enclosed and gasketed with 800 Lumen LED lightbulb.
- ⑩ 15 amp, 2-pole circuit breaker.
- ⑪ 60 amp\*, 2-pole circuit breaker.
- ⑫ Terminal block sized for conductors as shown on plans.

All dimensions are in inches (millimeters) unless otherwise shown.

Branch lighting circuits. (Total of four 20A 2-Pole breakers required) (Includes two spare circuit breakers)

FILE NAME =	USER NAME = howalder	DESIGNED -	REVISED -
\\Central\4\common\GEN\Transfer - bureau\68E79 - Final Plans\68E79 - Pekin Bridge		DRAWING, RWIS, and ITS (Final 12-10-19).dgn	REVISED -
	PLOT SCALE = 38.0588' / in.	CHECKED -	REVISED -
	PLOT DATE = 12/12/2019	DATE -	REVISED -

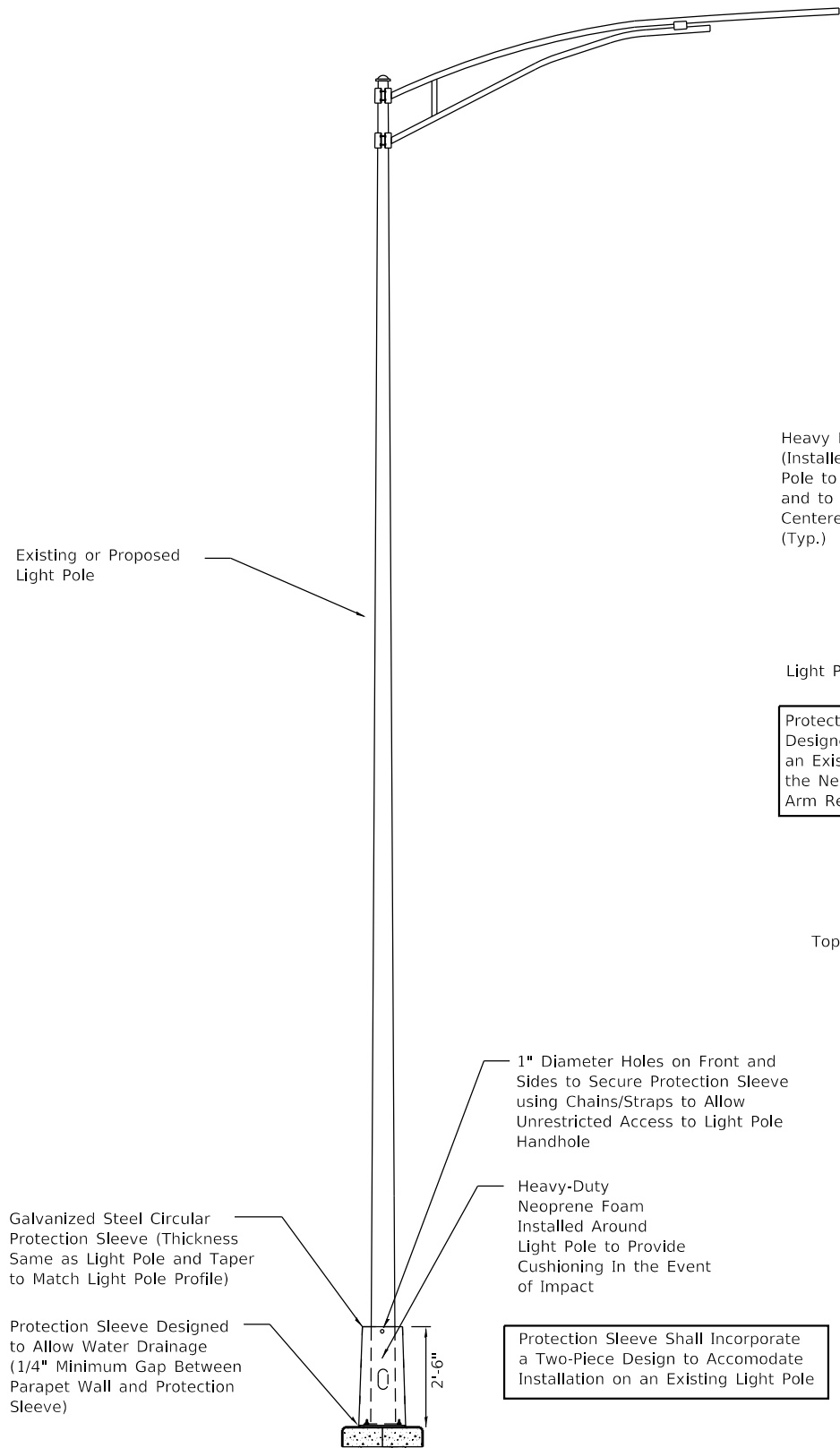
**STATE OF ILLINOIS  
DEPARTMENT OF TRANSPORTATION**

**PROPOSED LIGHTING CONTROLLER DETAIL  
PEKIN BRIDGE - PEORIA COUNTY**

SCALE: \_\_\_\_\_ STA. \_\_\_\_\_ TO STA. \_\_\_\_\_

**NOT TO SCALE  
ELECTRICAL SHEET 9 OF 10**

F.A.P. RTE.	SECTION	COUNTY	TOTAL SHEETS	SHEET NO.
693	(12B)BR,BDR,BJR	TAZEWELL	63	54
CONTRACT NO. 68E79				
ILLINOIS FED. AID PROJECT				



**MAST ARM  
LIGHT POLE  
PROTECTION  
SLEEVE**

Heavy Duty Neoprene Foam (Installed Around Light Pole to for Shock Absorption and to Keep Protection Sleeve Centered Around Light Pole (Typ.)

Light Pole Protection Sleeve

Protection Sleeve Shall be Designed for Installation on an Existing Light Pole without the Need for Pole or Luminaire Arm Removal

Top of Bridge Parapet

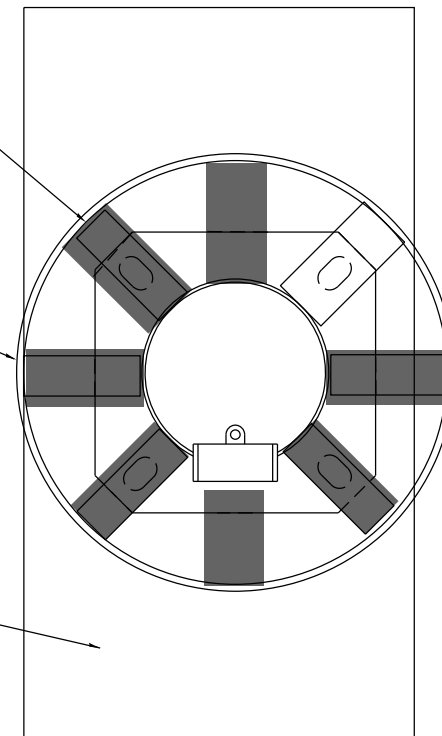
1" Diameter Holes on Front and Sides to Secure Protection Sleeve using Chains/Straps to Allow Unrestricted Access to Light Pole Handhole

Heavy-Duty Neoprene Foam Installed Around Light Pole to Provide Cushioning In the Event of Impact

Galvanized Steel Circular Protection Sleeve (Thickness Same as Light Pole and Taper to Match Light Pole Profile)

Protection Sleeve Designed to Allow Water Drainage (1/4" Minimum Gap Between Parapet Wall and Protection Sleeve)

Protection Sleeve Shall Incorporate a Two-Piece Design to Accomodate Installation on an Existing Light Pole



**GENERAL NOTES**

Light pole protection sleeve to be installed prior to mast arm installation.

Light pole protection sleeve to be constructed from galvanized steel with the same thickness as the light pole shown on Highway Standard 830011.

Light pole protection sleeve sized as required to provide a three inch minimum clearance around the existing light pole and light pole base.

Light pole protection sleeve to be designed to allow for unrestricted access to the light pole handhole (designed to be lifted up and secured to allow access to handhole).

Light pole protection sleeve to have a three inch wide band of high visibility fluorescent yellow reflective tape (AZ sheeting) on top and bottom.

Install high quality outdoor rated neoprene foam (appropriately sized strips or cubes) inside protection sleeve around light pole to keep sleeve optimally centered and provide cushioning/shock absorption to protect light pole in the event of a vehicle or snow plow blade impact.

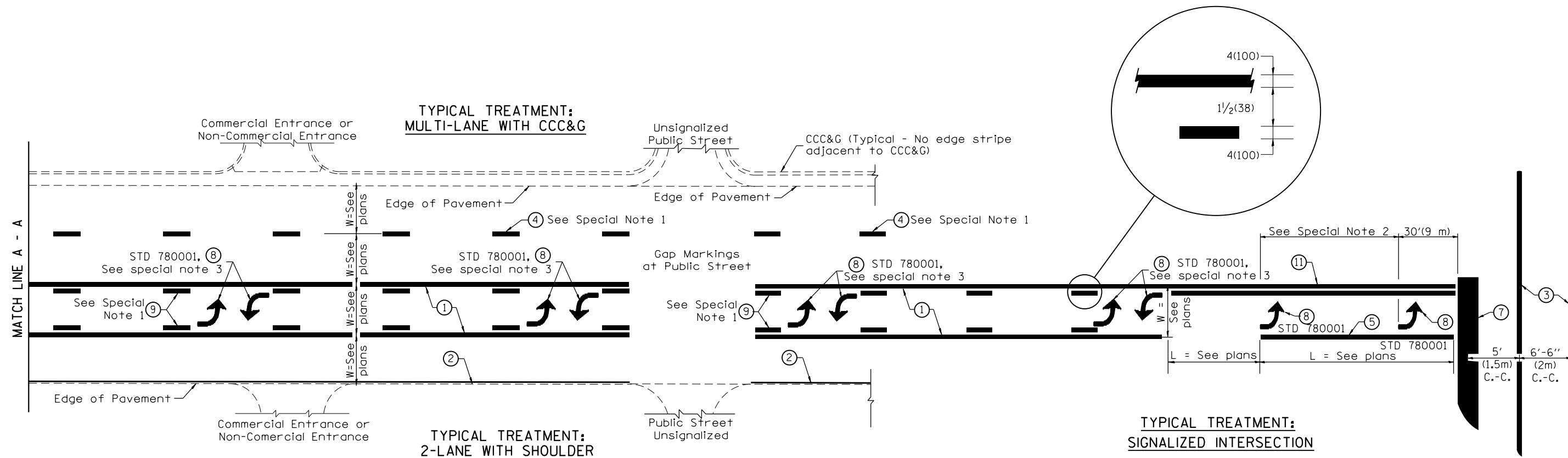
Light pole protection sleeve and cushioning material to be designed and installed to prevent accumulation of water inside protection sleeve.

Light pole protection sleeve to be designed for installation on an existing light pole without removing the pole or luminaire arm.

Contractor shall submit detailed drawings with catalog cut-sheets for all materials to the Department for review and approval prior to proceeding with fabrication.

**NOT TO SCALE  
ELECTRICAL SHEET 10 OF 10**

FILE NAME =	USER NAME = howlader	DESIGNED -	REVISED -	<b>STATE OF ILLINOIS DEPARTMENT OF TRANSPORTATION</b>	<b>LIGHT POLE PROTECTION SLEEVE DETAIL</b>	F.A.P. RTE.	SECTION	COUNTY	TOTAL SHEETS	SHEET NO.
\\Central\4\common\GEN\Transfer - bureau\68E79 - Final Plans\68E79 - Pekin Bridge	DRAWING, RWIS, and ITS (Final 12-10-19).dgn	REVISIONS	REVISED -			693	(12B)BR,BDR,BJR	TAZEWELL	63	55
PLOT SCALE = 38.0588' / in.	CHECKED -	REVISED -	CONTRACT NO. 68E79							
PLOT DATE = 12/12/2019	DATE -	REVISED -	ILLINOIS FED. AID PROJECT							
					SCALE:	STA.	TO STA.			



**FLUSH PAVED MEDIAN: TWO-WAY LEFT TURN LANE WITH ONE-WAY LEFT TURN LANE AT SIGNALIZED INTERSECTION**

**TYPICAL PAVEMENT MARKING LEGEND**

(Note: This is a District Standard Legend. Some elements may not apply to specific project.)

- ① 4(100) Solid (Yellow)
- ② 4(100) Solid (White)
- ③ 2-6(150) Crosswalk @ 6'-6" (2m)min C.-C. (White)  
2-8(200) Crosswalk @ 6'-6" (2m)min C.-C. (White) (When traffic signals are present.)
- ④ 6(150) Skip-Dash (White) (See Special Note 1)
- ⑤ 8(200) Solid (White)
- ⑥ 12(300) Diagonal (White) (Item ⑥ is shown on Std. 780001)
- ⑦ 24(600) Stop Bar (White)
- ⑧ Letters & Arrows (See Std. 780001 and Special Notes 2 & 3)
- ⑨ 4(100) Skip-Dash (Yellow) (See Special Note 1)
- ⑩ 12(300) Diagonal (Yellow) (See Table A) ⑩
- ⑪ 4(100) Double Solid (Yellow) ⑪

**SPECIAL NOTES**

- Skip-Dash markings will be centered between both ends of city blocks and shall be placed in alignment transversely across the pavement.
- The following shall apply to arrows located in one-way left turn lanes:
  - A minimum of two (2) arrows is required.
  - The maximum spacing between arrows is 80' (24 m).
  - Arrows shall be evenly spaced if three (3) or more are required.
- The following shall apply to arrow pairs located in two-way left turn lanes:
  - A minimum of two (2) arrow pairs is required.
  - The maximum spacing between arrow pairs is 200' (61 m).
  - Arrow pairs shall be evenly spaced if three (3) or more are required.
  - The spacing between Bi Directional Left Turn Arrows is 33' (10 m).

**GENERAL NOTES**

- Refer to State Standard 780001 for additional Pavement Markings including letters & arrows.
- See Plans for Pavement Markings adjacent to curbed islands and medians, and through lane reductions.
- Refer to Article 780.13 for letter, number and symbol areas (sq. ft.)
- Areas are grooved 1" beyond each edge for the following symbols:  
Through Arrow= 14.8 sq. ft.  
Large Left or Right Arrow= 21.9 sq. ft.  
2 Arrow Combination Left (or Right) and Through= 34.9 sq. ft.  
Wrong Way Arrow= 29.5 sq. ft.  
Railroad Crossing Symbol= 69.8 sq. ft.  
(For further information, refer to BDE Special Provision: Grooving for Recessed Pavement Markings)

01-01-97	RENUM. F-8.03, NEW REVISION BOX	T.P.	10-16-06	REVISED TO 2007 SPEC.	
02-07-97	ADD BI DIRECTIONAL DIMENSION	J.A.	2/29/16	ADDED GROOVING AREAS	R.D.
10-97	CORRECT BI DIRECTIONAL DIMENSION	J.A.	07-16-19	SPELLING CORRECTIONS	R.D.
08-02	ADD CROSSWALK DMNS. WITH T.S.	M.A.			

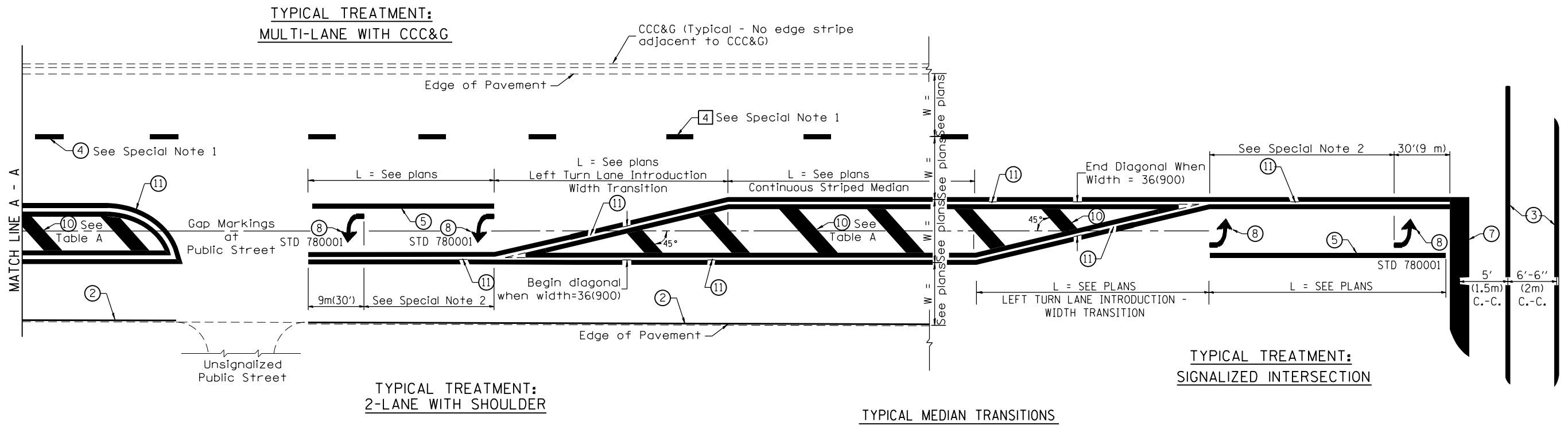
**STATE OF ILLINOIS  
DEPARTMENT OF TRANSPORTATION**

NOT TO SCALE

**TYPICAL PAVEMENT MARKINGS**

SHT. 1 OF 2  
CADD STD. 780001-D4

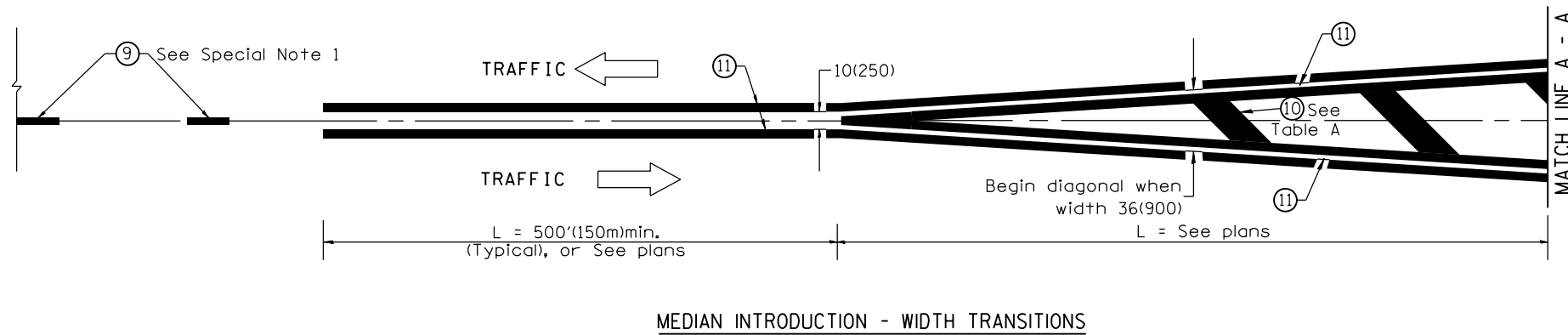
F.A.P. RTE.	SECTION	COUNTY	TOTAL SHEETS	SHEET NO.
693	(12B)BR+BDR,BJR	TAZEWELL	63	56
FED. ROAD DIST. NO. ILLINOIS FED. AID PROJECT			CONTRACT NO. 68E79	



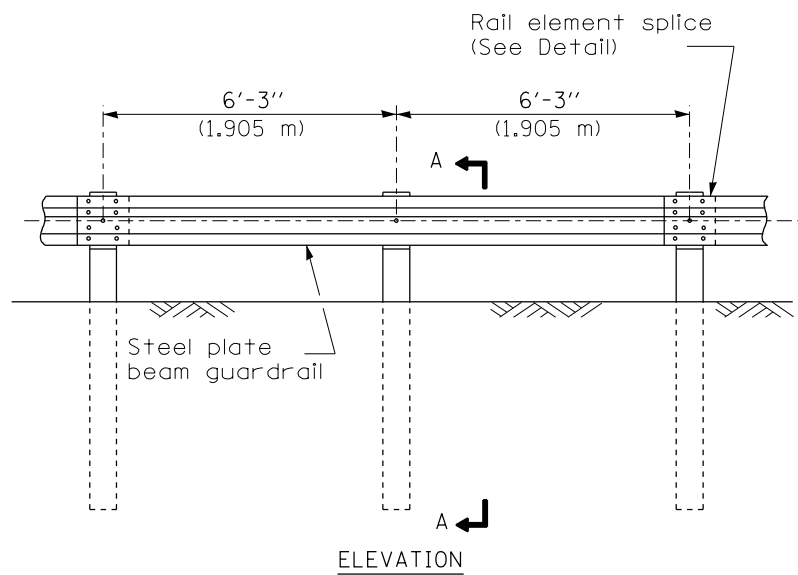
FLUSH PAVED MEDIAN: RESTRICTED LEFT TURN LANE

TABLE A  
RECOMMENDED SPACING BETWEEN DIAGONAL LINES

SPEED LIMIT RANGE	INTERSECTION CHANNELIZATION (Includes Width Transitions for Median and Left Turn Lane Introductions)	
	CONTINUOUS	
Less Than 30 mph (50 km/h)	50' (15m)	15' (5m)
30 - 45 mph (50 - 70 km/h)	75' (23m)	20' (6m)
Over 45 mph (70 km/h)	150' (46m)	30' (9m)

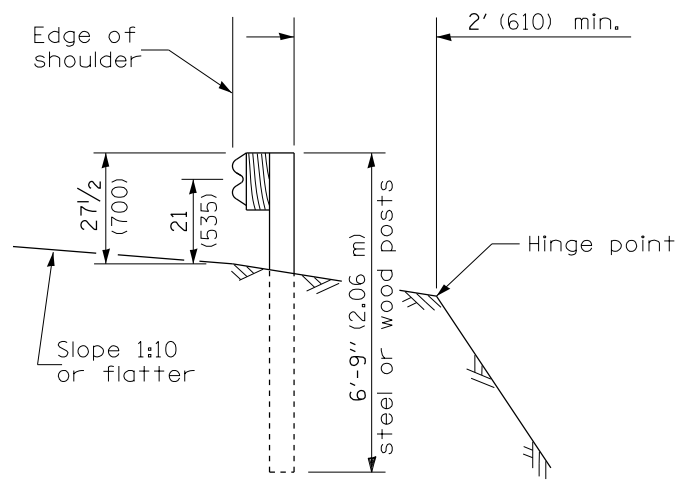


All dimensions are in inches (millimeters) unless otherwise noted.

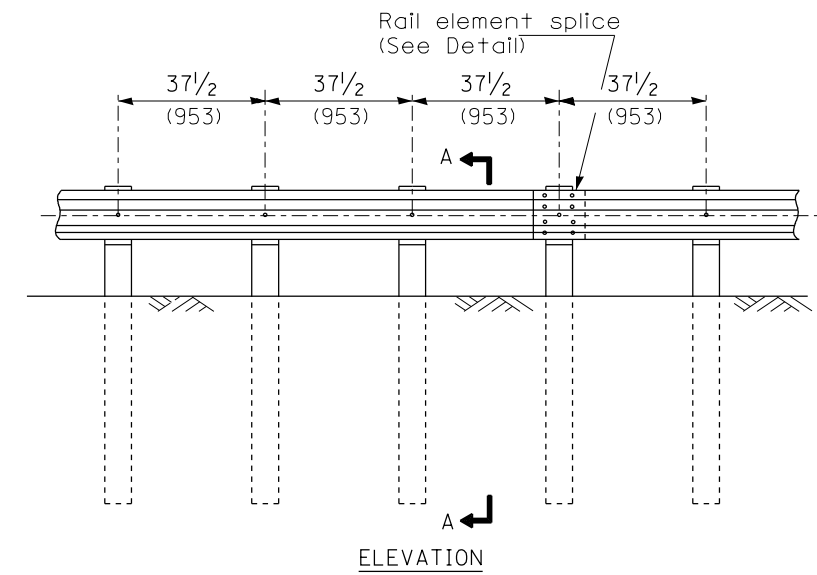


**TYPE A**

6'-3" (1.905 m) Typical post spacing

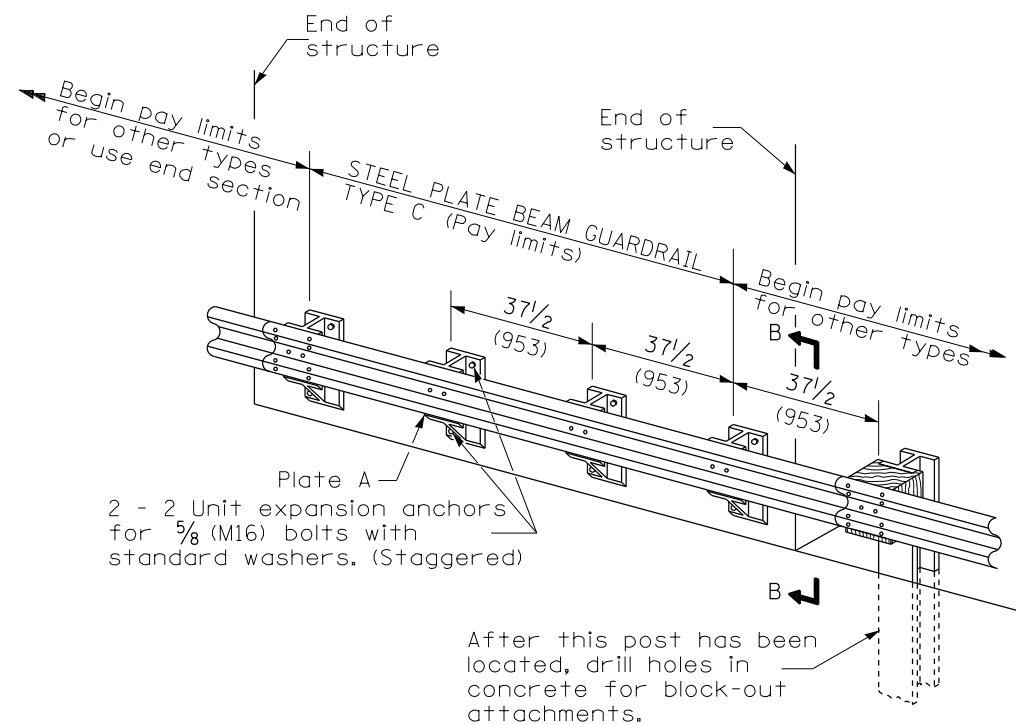


**SECTION A-A**



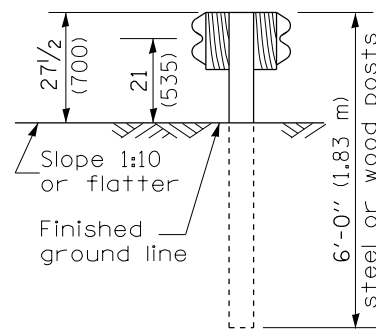
**TYPE B**

37 1/2 (953) Closed post spacing

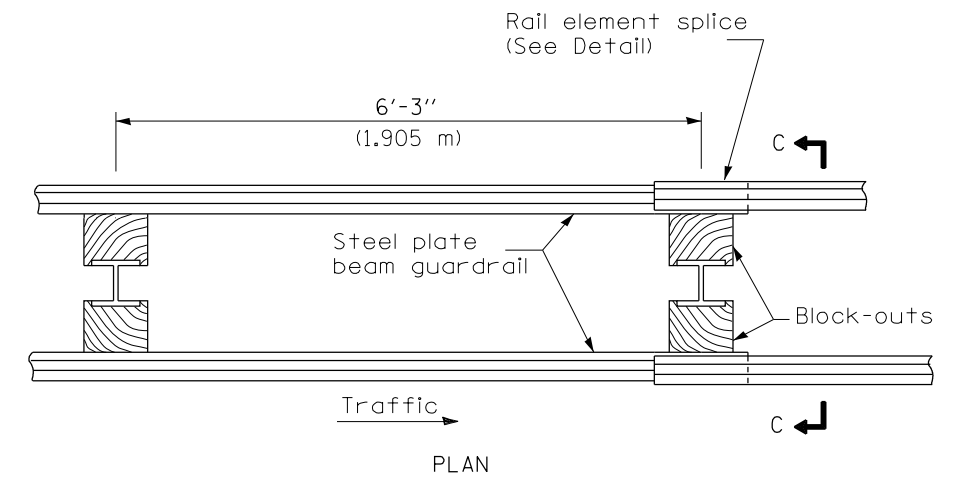


**TYPE C**

37 1/2 (953) Block-out spacing

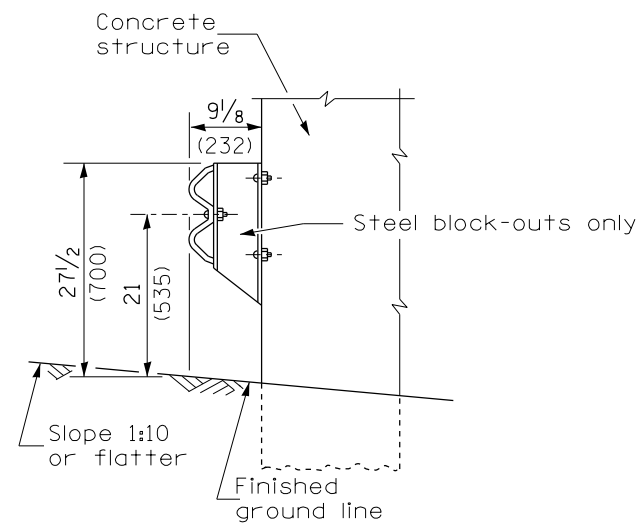


**SECTION C-C**



**TYPE D**

Double steel plate beam guardrail  
6'-3" (1.905 m) typical post spacing



**SECTION B-B**

**GENERAL NOTES**

All slope ratios are expressed as units of vertical displacement to units of horizontal displacement (V:H).

All dimensions are in millimeters (inches) unless otherwise shown.

The existing steel posts may be drilled to match the bolt pattern shown herein for the wood block-out, or a new steel post shall be provided.

This detail is applicable to the guardrail system used prior to January 1, 2007. For details on the Midwest Guardrail System, see Standard 630001.

All dimensions are in inches (millimeters) unless otherwise noted.

03-01-07	NEW DETAIL	RJD			
03-07-11	Revised designer note	RJD			

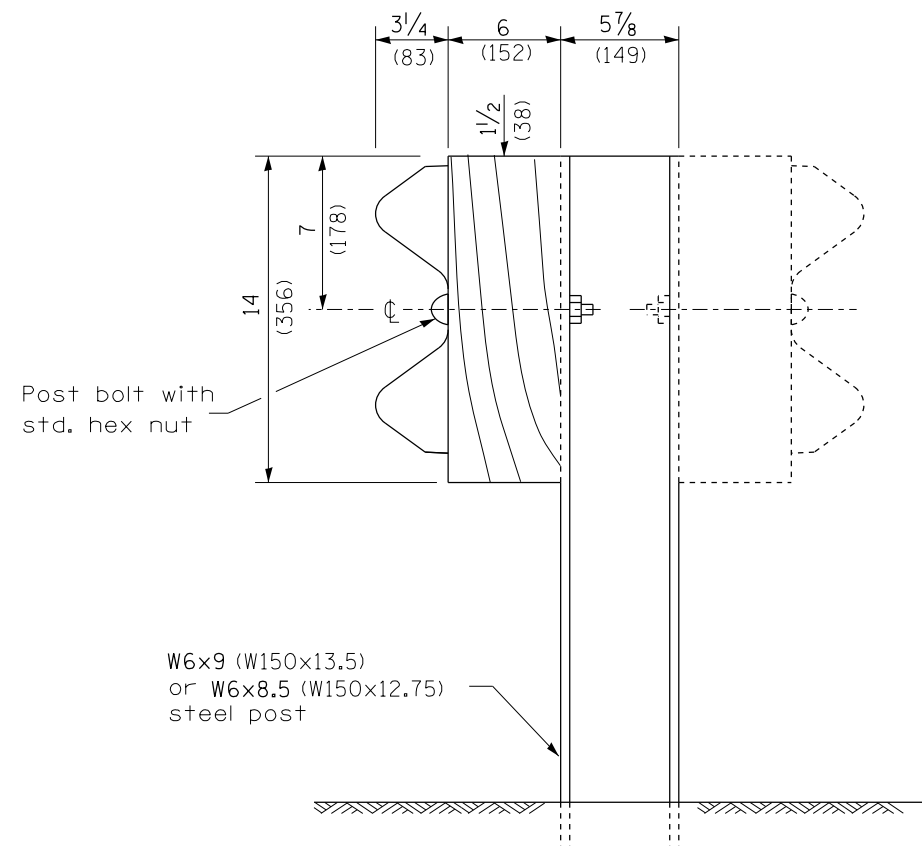
**STATE OF ILLINOIS  
DEPARTMENT OF TRANSPORTATION**

NOT TO SCALE

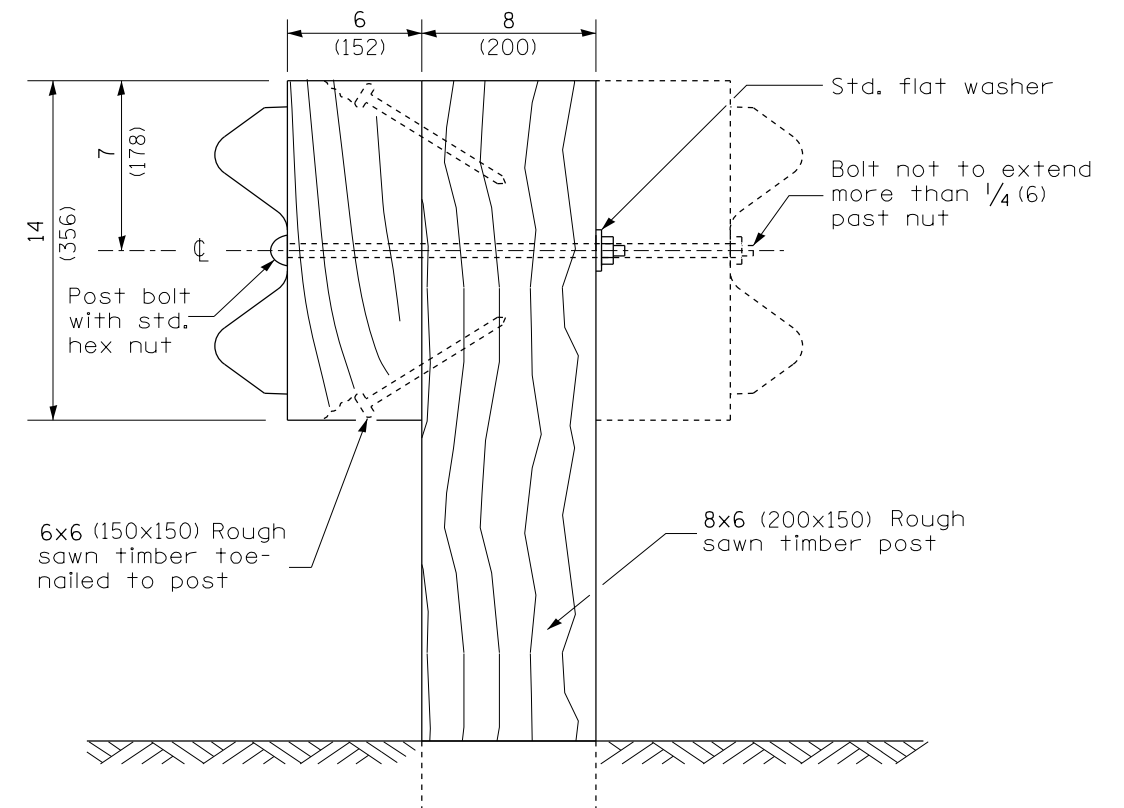
**STEEL PLATE BEAM GUARDRAIL, TYPE A,  
6.75 FOOT POSTS**

SHT. 1 OF 4  
CADD STD. 630011-D4

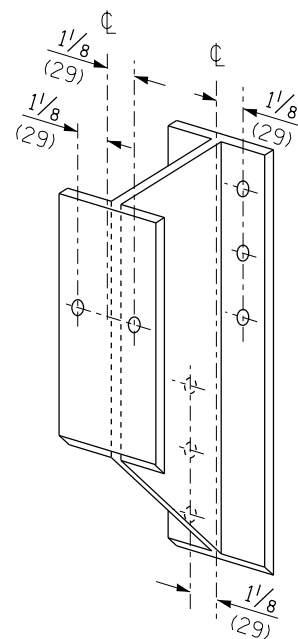
F.A.P. RTE.	SECTION	COUNTY	TOTAL SHEETS	SHEET NO.
693	(12B)BR,BDR,BJR	TAZEWELL	63	58
FED. ROAD DIST. NO.			ILLINOIS FED. AID PROJECT	



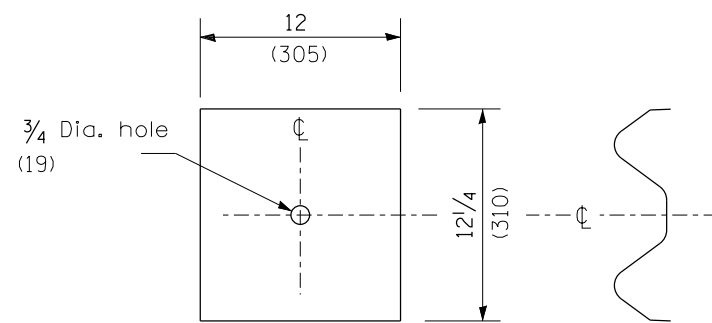
**STEEL POST CONSTRUCTION**



**WOOD POST CONSTRUCTION**



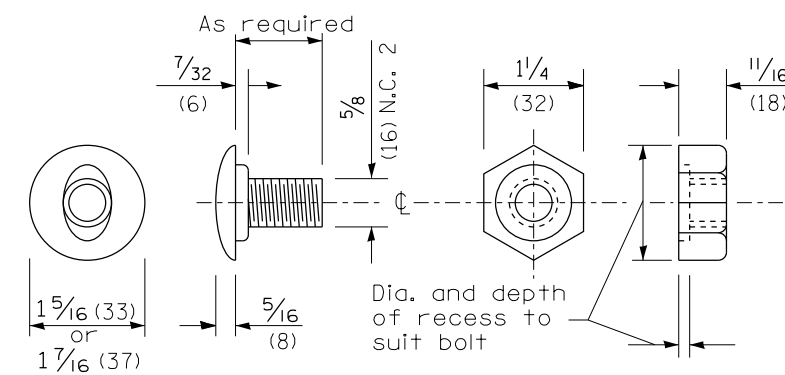
**STEEL BLOCK-OUT DETAIL**



**NOTE**

Plate A shall be placed between rail element and block-out at non-splice mounting points only when steel block-outs are used.

**PLATE A**



**POST OR SPLICE BOLT & NUT**

All dimensions are in inches (millimeters) unless otherwise noted.


STATE OF ILLINOIS  
DEPARTMENT OF TRANSPORTATION

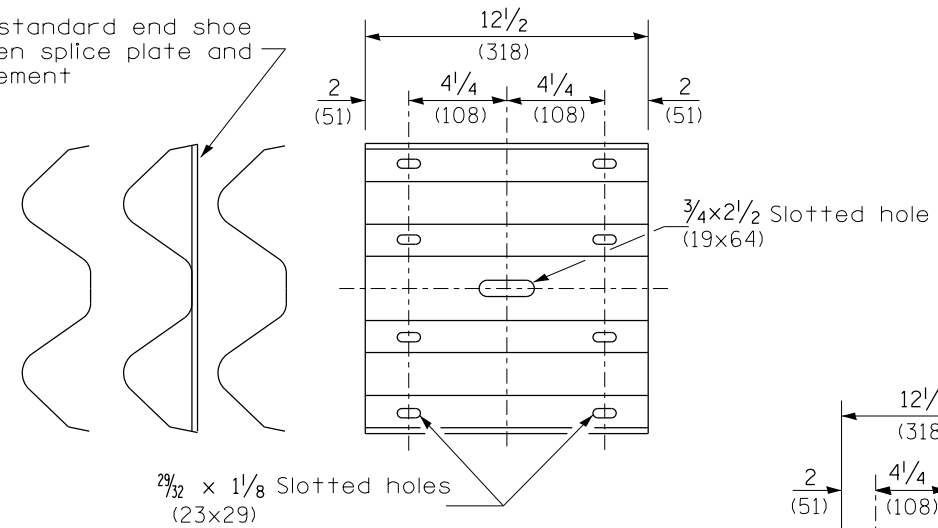
STEEL PLATE BEAM GUARDRAIL, TYPE A,  
6.75 FOOT POSTS

NOT TO SCALE

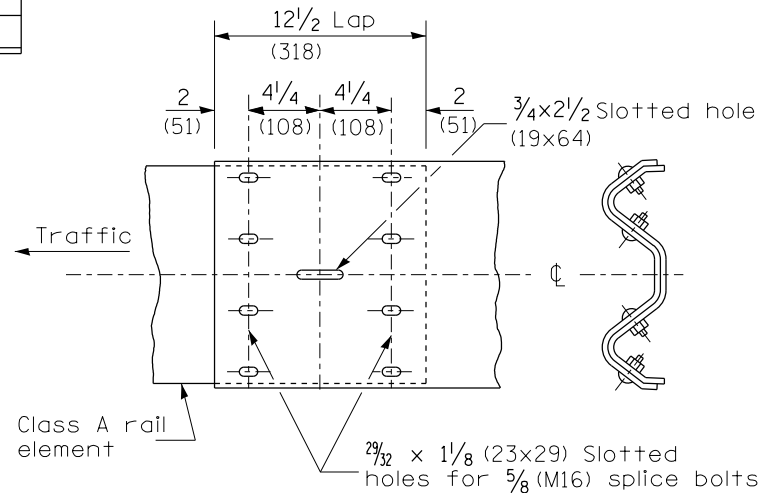
SHT. 2 OF 4  
CADD STD. 630011-D4

F.A.P. RTE.	SECTION	COUNTY	TOTAL SHEETS	SHEET NO.
693	(12B)BR,BDR,BJR	TAZEWELL	63	59
FED. ROAD DIST. NO. ILLINOIS FED. AID PROJECT			CONTRACT NO. 68E79	

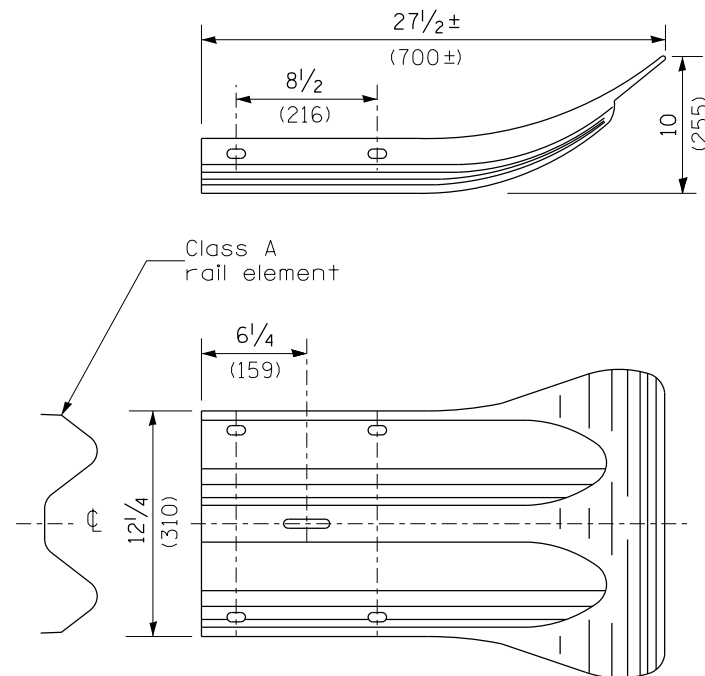
Place standard end shoe between splice plate and rail element



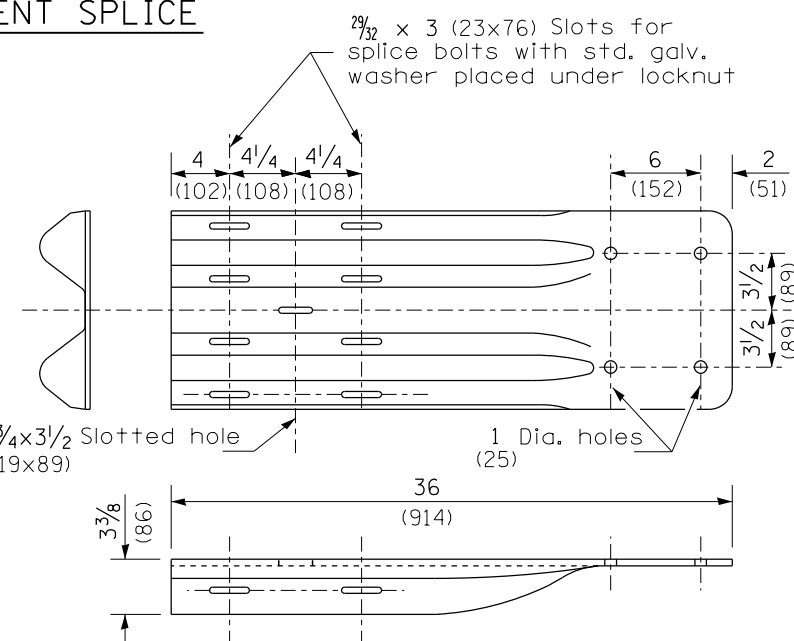
**SPLICE PLATE**



**RAIL ELEMENT SPLICE**



**END SECTION**



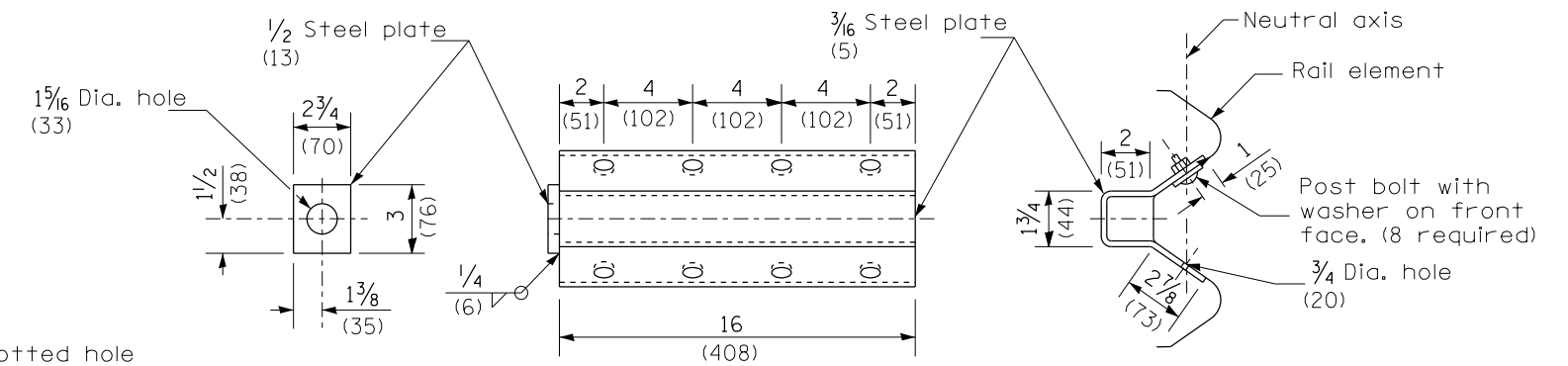
NOTE

When end shoe is attached to a bridge parapet which has an expansion joint, the bolts shall be provided with a locknut or double nut and shall be tightened only to a point that will allow guardrail movement.

The standard end shoe shall be attached to the concrete with pre-drilled or self-drilling anchor bolts. The anchor cone shall be set flush with the surface of the concrete.

Externally threaded studs protruding from the surface of the concrete will not be permitted.

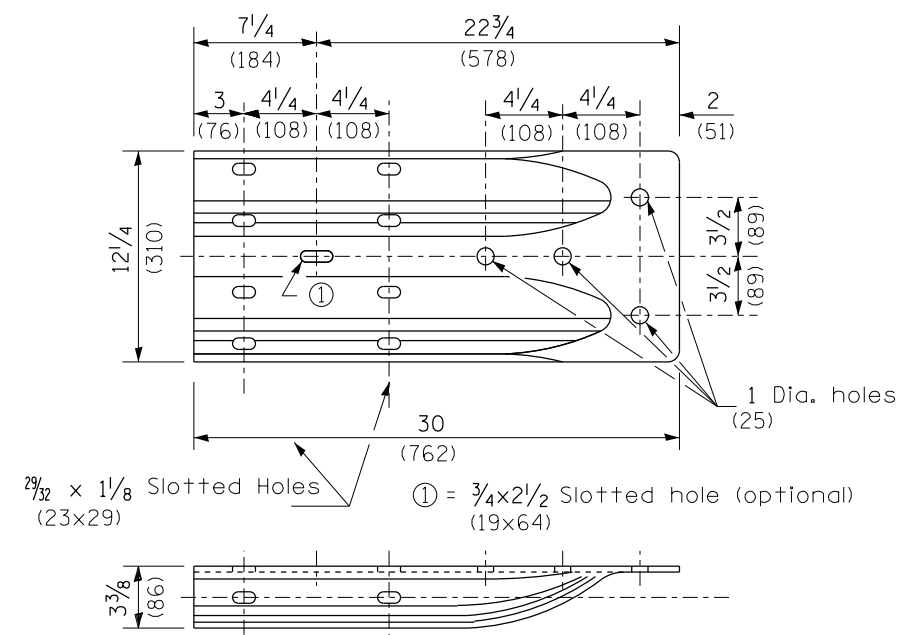
**END SHOE**



NOTE

Anchor plate T shall be used to attach cable assembly to guardrail when required on traffic barrier terminals.

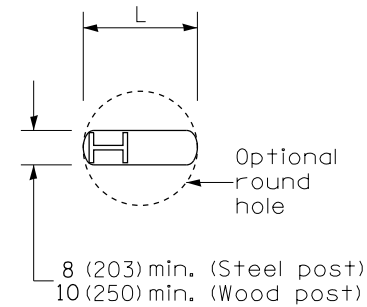
**ANCHOR PLATE T DETAILS**



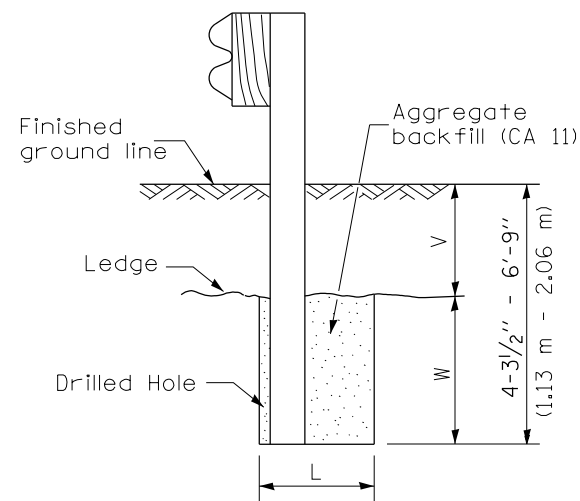
**ALTERNATE END SHOE**

All dimensions are in inches (millimeters) unless otherwise noted.

STATE OF ILLINOIS DEPARTMENT OF TRANSPORTATION		STEEL PLATE BEAM GUARDRAIL, TYPE A, 6.75 FOOT POSTS		F.A.P. RTE.	SECTION	COUNTY	TOTAL SHEETS	SHEET NO.
		NOT TO SCALE		693	(12B)BR,BDR,BJR	TAZEWELL	63	60
		SHT. 3 OF 4 CADD STD. 630011-D4		CONTRACT NO. 68E79				
				FED. ROAD DIST. NO. ILLINOIS FED. AID PROJECT				

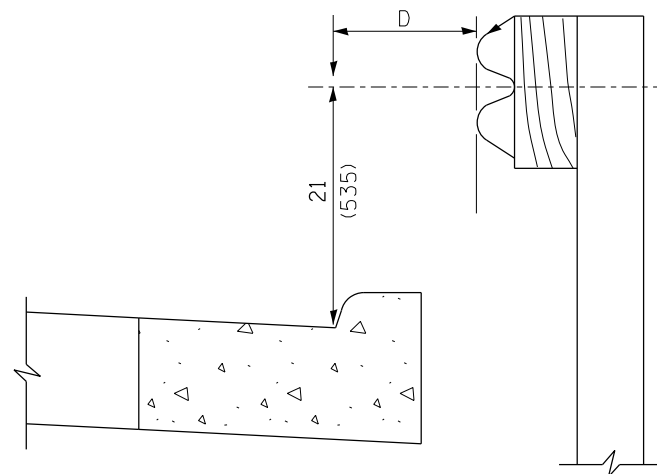


PLAN



ELEVATION

FOOTING FOR POST WHEN IMPERVIOUS MATERIAL IS ENCOUNTERED



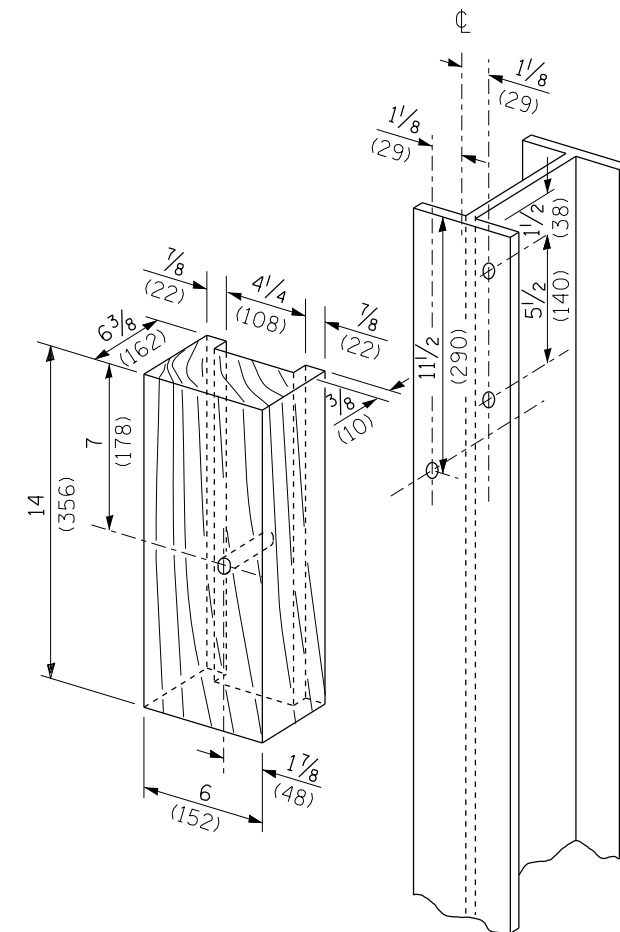
Note:

If it is necessary for D to be more than 12 (300) and less than 10'-0" (3.0 m) type M-2 (M-5) curb and gutter (Std. 606001) shall be used in front of and in advance of the guardrail.

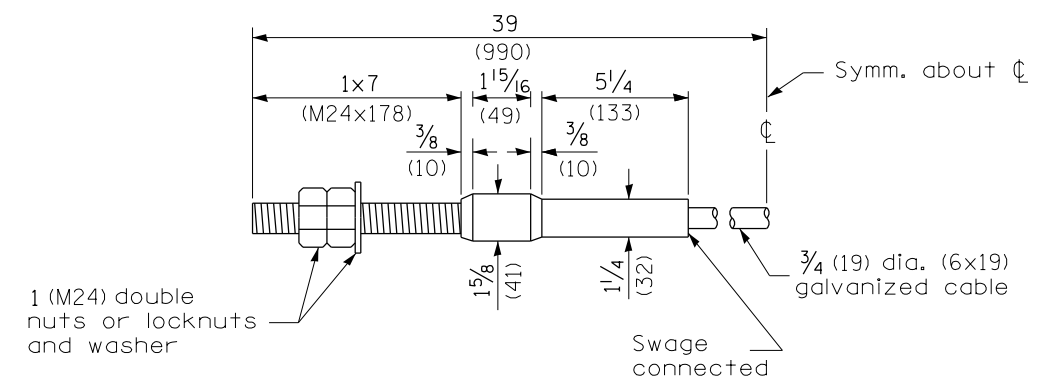
GUARDRAIL PLACED BEHIND CURB

(D = 0 desirable to 12 (300) maximum)

V	W	L	
		Steel Post	Wood Post
0 - 18 (0 - 460)	24 (610)	21 (530)	23 (580)
>18 - 41.5 (>460 - 825)	12 (305)	8 (203)	10 (250)
>41.5 - 53.5 (>825 - 1.13 m)	12 - 0 (305 - 0)	8 (203)	10 (250)



WOOD BLOCK-OUT AND STEEL POST DETAILS



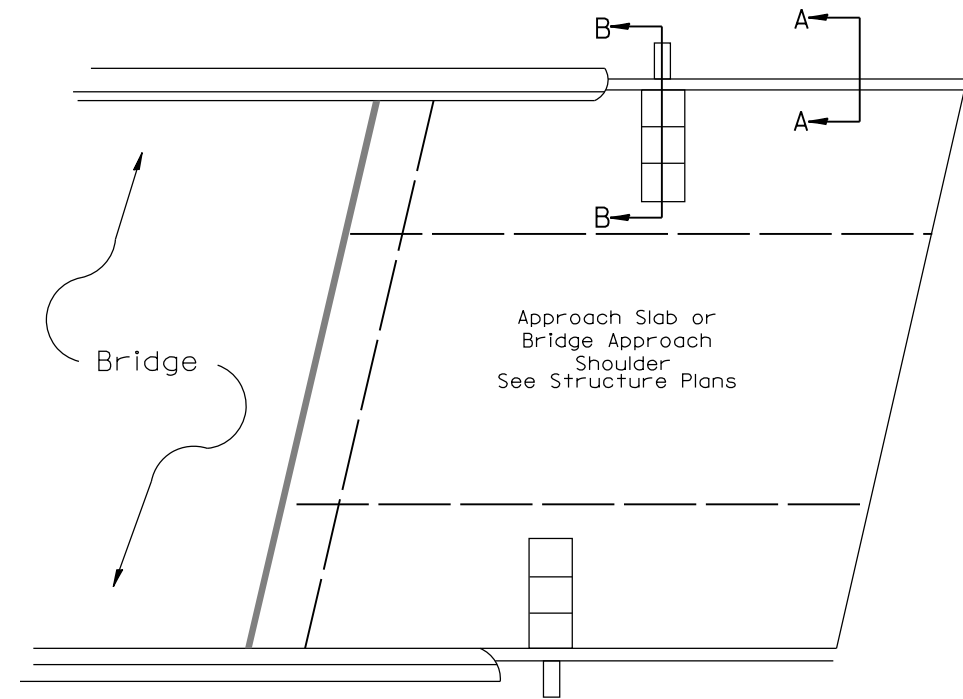
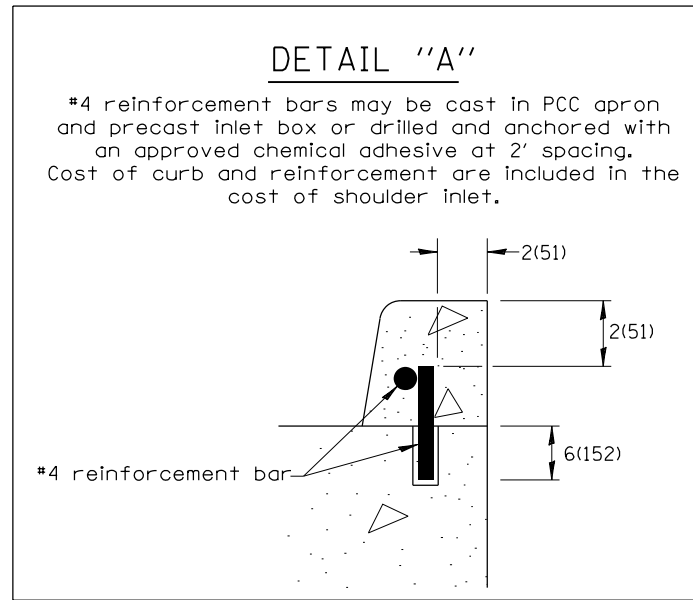
CABLE ASSEMBLY

(18,100 kg (40,000 lbs.) min. breaking strength)  
Tighten to taut tension.

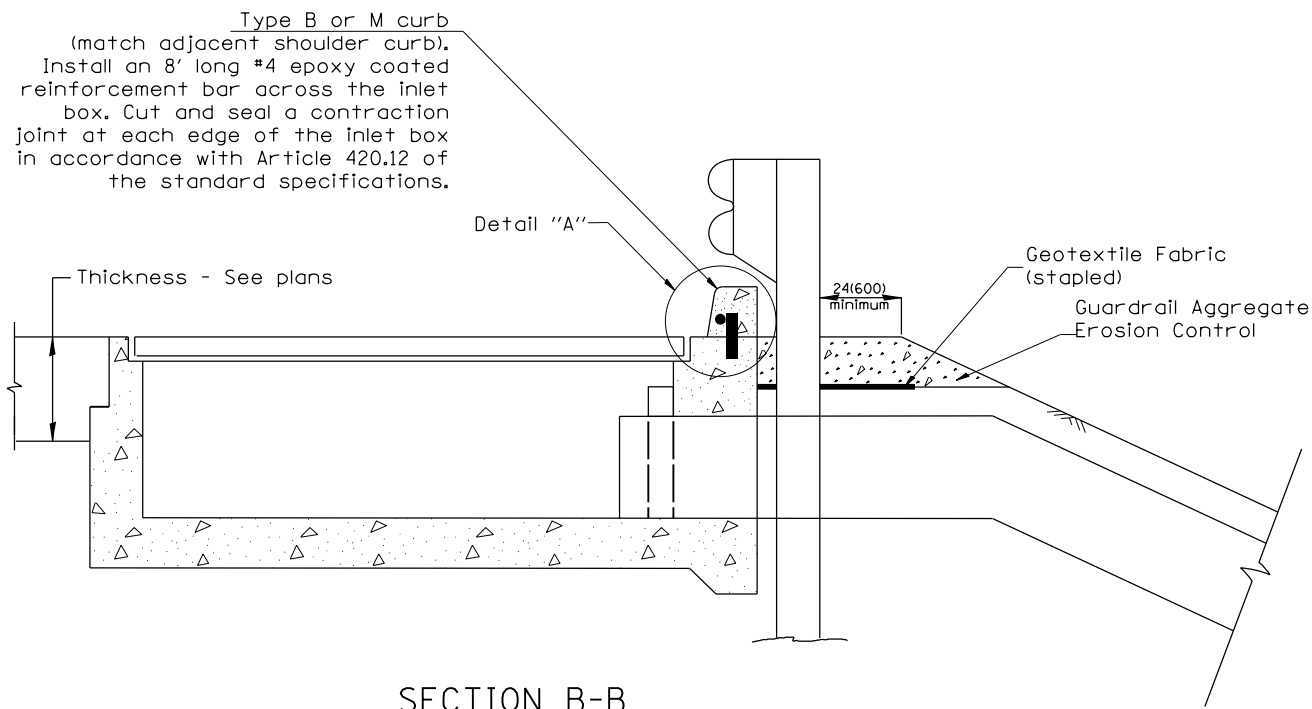
All dimensions are in inches (millimeters) unless otherwise noted.



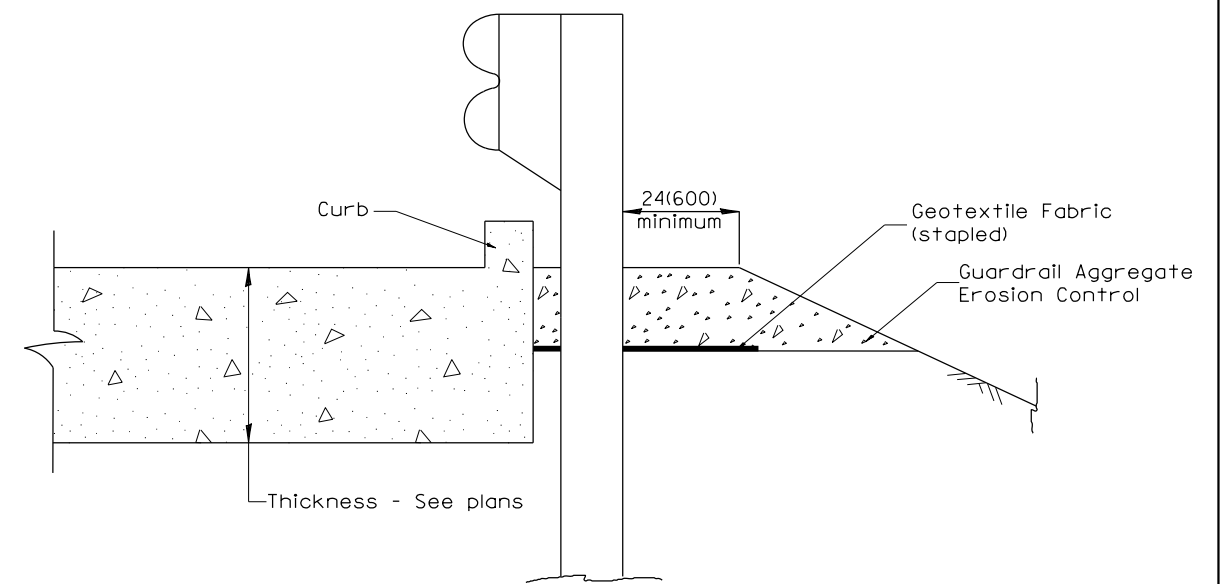




**PLAN VIEW**  
**APPROACH SLAB OR SHOULDER PLACEMENT**



**SECTION B-B**  
**TYPICAL SECTION AT INLETS**  
**TYPE E, F & G (HIGHWAY STANDARD 610001)**



**SECTION A-A**  
**TYPICAL SECTION WITH BRIDGE APPROACH CURB**

All dimensions are in inches (millimeters) unless otherwise noted.

<b>STATE OF ILLINOIS</b>				<b>GUARDRAIL EROSION CONTROL TREATMENTS</b>				TOTAL SHEETS	SHEET NO.
<b>DEPARTMENT OF TRANSPORTATION</b>				NOT TO SCALE				63	63
				SHT. 2 OF 2				CONTRACT NO. 68E79	
				CADD STD. 630101-D4				ILLINOIS FED. AID PROJECT	