

F.A.P. RTE.	SECTION	COUNTY	TOTAL SHEETS	SHEET NO.
308	1(HB,HB-1,VB,HB-2)R	ROCK ISLAND	210	1
			+19	
			229	

STATE OF ILLINOIS
DEPARTMENT OF TRANSPORTATION
DIVISION OF HIGHWAYS

**PROPOSED
HIGHWAY PLANS**

F.A.P. ROUTE 308 (ILLINOIS ROUTE 92)
SECTION 1(HB,HB-1,VB,HB-2)R
PROJECT BRF-BHF-0308(032)
ROCK ISLAND COUNTY
C-92-049-07

FOR INDEX OF SHEETS, SEE SHEET NO. 2

D-92-044-02



LOCATION OF SECTION INDICATED THUS: - ■ -

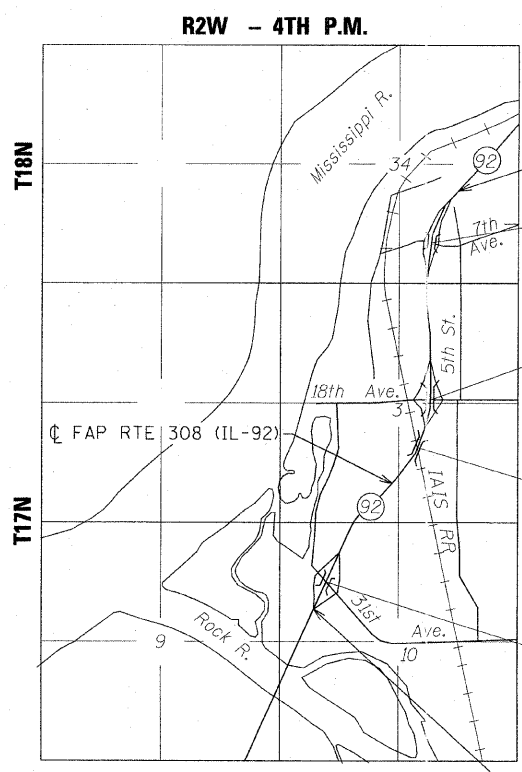

LOCATION MAP
SCALE - IWA

- PROJECT ENDS**
STA. 1561 + 63.55
- STRUCTURE NO. 081-0170**
STA. 1546 + 62.54 TO STA. 1547 + 82.55
INCLUDES A 3-SPAN CONTINUOUS ROLLED BEAM STRUCTURE (CARRYING FAP ROUTE 308 OVER 7TH AVENUE) ON TWO REINFORCED CONCRETE PIERS AND INTEGRAL ABUTMENTS
SPANS 1@27.25'; 2@61.67'; 3@27.25'
- STRUCTURE NO. 081-0171**
STA. 1517 + 18.80 TO STA. 1518 + 36.32
INCLUDES A 3-SPAN CONTINUOUS ROLLED BEAM STRUCTURE (CARRYING FAP ROUTE 308 OVER 18TH AVENUE) ON TWO PILE BENT PIERS AND INTEGRAL ABUTMENTS.
SPANS 1@27.5'; 2@60'; 3@27.5'
- STRUCTURE NO. 081-0064**
STA. 1505 + 95.93 TO STA. 1508 + 20.92
INCLUDES DECK REPLACEMENT ON AN EXISTING 3-SPAN CONTINUOUS ROLLED BEAM STRUCTURE (CARRYING FAP ROUTE 308 OVER THE IAS RAIL ROAD) ON TWO EXISTING REINFORCED CONCRETE PIERS AND PILE BENT ABUTMENTS.
SPANS 1@70.1'; 2@89.75'; 3@65.3'
- STRUCTURE NO. 081-0172(SB)**
STRUCTURE NO. 081-0172(NB)
STA. 1470 + 20.29 TO STA. 1471 + 47.95 (SB)
STA. 1469 + 92.67 TO STA. 1471 + 20.34 (NB)
INCLUDES TWIN 3-SPAN CONTINUOUS ROLLED BEAM STRUCTURES (CARRYING FAP ROUTE 308 OVER 31ST AVENUE) ON TWO PILE BENT PIERS EACH AND INTEGRAL ABUTMENTS.
SPANS 1@30.55'; 2@63.83'; 3@30.55'

PROJECT BEGINS
STA. 1463 + 87.27

GROSS LENGTH OF PROJECT = 9,776 FEET (1.82 MILES)
NET LENGTH OF PROJECT = 9,776 FEET (1.82 MILES)

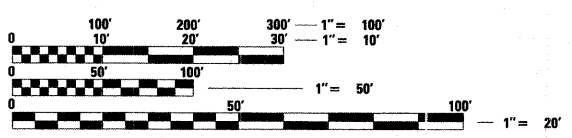

Andrew K. Kassay 12/6/07
EXPIRES 11/30/09
APPLIES TO SHEETS 1-84G

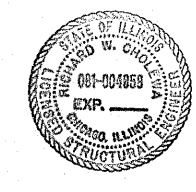

Richard W. Cholewa 12/6/07
EXPIRES 11/30/08
APPLIES TO SHEETS 85-103, 107-141, 144-166, 169-194 & 197-202

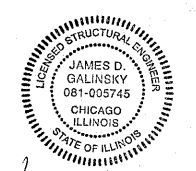

James D. Galinsky 12/5/07
EXPIRES 11/20/08
APPLIES TO SHEETS 104-106, 142-143, 167-168 & 195-196



Christopher L. Krueger 12/6/07
EXPIRES 11/30/09
APPLIES TO SHEETS 203-210

**100% SUBMITTAL
12/07/2007**

STATE OF ILLINOIS
DEPARTMENT OF TRANSPORTATION
DIVISION OF HIGHWAYS

SUBMITTED December 20 20 07

George F. Ryan
DEPUTY DIRECTOR OF HIGHWAYS, REGION ENGINEER

February 1, 20 08
Eric E. Harman
ENGINEER OF DESIGN AND ENVIRONMENT

February 1, 20 08
Christine M. Reed
DIRECTOR OF HIGHWAYS, CHIEF ENGINEER

FULL SIZE PLANS HAVE BEEN PREPARED USING STANDARD ENGINEERING SCALES. REDUCED SIZED PLANS WILL NOT CONFORM TO STANDARD SCALES. IN MAKING MEASUREMENTS ON REDUCED PLANS, THE ABOVE SCALES MAY BE USED.

J.U.L.I.E.
JOINT UTILITY LOCATION INFORMATION FOR EXCAVATION
1-800-892-0123

ROCK ISLAND AND SOUTH ROCK ISLAND TOWNSHIPS
CONTRACT NO. 64814

LOCHNER
H.W. LOCHNER, INC., CHICAGO, ILLINOIS

**PRINTED BY THE AUTHORITY
OF THE STATE OF ILLINOIS**

PROJECT ENGINEER
REBECCA MARRUFFO

DERRICK LOPEZ
SQUAD LEADER
(815) 284-5950

RICK CHOLEWA
H.W. LOCHNER
312-372-3011

F.A.P. RTE.	SECTION	COUNTY	TOTAL SHEETS	SHEET NO.
308	116B,118-1,119B,120-2R	ROCK ISLAND	210	2
STA.		TO STA.		
FED. ROAD DIST. NO. 2		ILLINOIS FED. AID PROJECT		

INDEX OF SHEETS

SHEET NO.	DESCRIPTION
1	COVER SHEET
2	INDEX OF SHEETS AND STATE STANDARDS
3-4	GENERAL NOTES
5-6C	SUMMARY OF QUANTITIES
7-10	TYPICAL SECTIONS
11-22B	SCHEDULES OF QUANTITIES
23-24	HORIZONTAL AND VERTICAL CONTROL SHEETS
25-45	PLAN AND PROFILE SHEETS
46-67B	STAGING PLANS
68-75	EROSION CONTROL PLANS
76-82A	DETAILS
83-84F	CROSS SECTIONS
85-115	STRUCTURE PLANS - 31ST AVENUE
116-147	STRUCTURE PLANS - IAIS RAILROAD
148-175	STRUCTURE PLANS - 18TH AVENUE
176-202	STRUCTURE PLANS - 7TH AVENUE
203-210	ROADWAY LIGHTING

DISTRICT STANDARDS

23.4	DETAIL OF HOT-MIX ASPHALT SHOULDER AT GUARD RAIL
23.4A	HOT-MIX ASPHALT SHOULDER
37.4	DELINEATOR AND POST ORIENTATION
39.4	INFORMATIONAL WARNING SIGN (FOR NARROW TRAVEL LANES)
43.4	REQUIRED COLD MILLED SURFACE TEXTURE
89.4	LETTERING FOR NAME PLATE
92.4	BARRIER REFLECTORS
98.4	TYPICAL MEDIAN CROSSOVER CLOSURE
29.2	EROSION CONTROL DETAILS FOR SILT FENCE
66.2	WITNESS MARKER & PERMANENT SURVEY MARKERS, TYPE II
2.1	STORM WATER POLLUTION PREVENTION PLAN
41.1	TYPICAL PAVEMENT MARKINGS SHEET 1 OF 2
41.1	TYPICAL PAVEMENT MARKINGS SHEET 2 OF 2
44.1	PAINTING DETAILS

STATE STANDARDS

000001-05	STANDARD SYMBOLS, ABBREVIATIONS AND PATTERNS
001001-01	AREAS OF REINFORCEMENT BARS
001006	DECIMAL OF AN INCH AND OF A FOOT
280001-04	TEMPORARY EROSION CONTROL SYSTEMS
420001-07	PAVEMENT JOINTS
420401-06	BRIDGE APPROACH PAVEMENT
442001-04	CLASS A PATCHES
482006-03	HMA SHOULDER ADJACENT TO RIGID PAVEMENT
515001-02	NAME PLATE FOR BRIDGES
542401	METAL END SECTION FOR PIPE CULVERTS
602101-01	DRAINAGE STRUCTURES TYPES 1, 2 & 3
602701-01	MANHOLE STEPS
606001-03	CONCRETE CURB TYPE B AND COMBINATION CONCRETE CURB AND GUTTER
609006-03	BRIDGE APPROACH PAVEMENT (DRAIN DETAIL)
630001-07	STEEL PLATE BEAM GUARDRAIL
630201-05	PCC/HMA STABILIZATION AT STEEL PLATE BEAM GUARDRAIL
630301-04	SHOULDER WIDENING FOR TYPE 1 (SPECIAL) GUARDRAIL TERMINALS
631011-04	TRAFFIC BARRIER TERMINAL, TYPE 2
631026-04	TRAFFIC BARRIER TERMINAL, TYPE 5
631031-06	TRAFFIC BARRIER TERMINAL, TYPE 6
631032-03	TRAFFIC BARRIER TERMINAL, TYPE 6A
635001	DELINEATORS
635006-02	REFLECTOR AND TERMINAL MARKER PLACEMENT
635011-01	REFLECTOR MARKER AND MOUNTING DETAILS
637001-03	CONCRETE BARRIER 815 MM (32 IN.) HEIGHT
642001	SHOULDER RUMBLE STRIPS
667101	PERMANENT SURVEY MARKERS
701006-02	OFF-ROAD OPERATIONS, 2L, 2W, 4.5 M (15') TO 600 MM (24") FROM PAVEMENT EDGE
701101-01	OFF-ROAD OPERATIONS, MULTILANE, 4.5 M (15') TO 600 MM (24") FROM PAVEMENT EDGE
701400-02	APPROACH TO LANE CLOSURE, FREEWAY/EXPRESSWAY
701401-04	LANE CLOSURE, FREEWAY/EXPRESSWAY
701402-06	LANE CLOSURE, FREEWAY/EXPRESSWAY, WITH BARRIER
701411-04	LANE CLOSURE, MULTILANE, AT ENTRANCE OR EXIT RAMP, FOR SPEEDS >= 45 MPH
701416-05	LANE CLOSURE, FREEWAY/EXPRESSWAY, WITH CROSSOVER AND BARRIER
701606-05	URBAN LANE CLOSURE, MULTILANE, 2W WITH MOUNTABLE MEDIAN
701901	TRAFFIC CONTROL DEVICES
704001-04	TEMPORARY CONCRETE BARRIER
720011	METAL POSTS FOR SIGNS, MARKERS & DELINEATORS
728001	TELESCOPING STEEL SIGN SUPPORT
729001	APPLICATIONS OF TYPES A & B METAL POSTS (FOR SIGNS & MARKERS)
780001-01	TYPICAL PAVEMENT MARKINGS
601101	CONCRETE HEADWALL FOR PIPE DRAIN

PLOT DATE = \$DATE\$
 FILE NAME = \$FILE\$
 PLOT SCALE = \$SCALE\$
 USER NAME = \$USER\$

REVISIONS		ILLINOIS DEPARTMENT OF TRANSPORTATION
NAME	DATE	
		SCALE: NONE DATE DRAWN BY AMK CHECKED BY MGZ

GENERAL NOTES

F.A.P. RTE.	SECTION	COUNTY	TOTAL SHEETS	SHEET NO.
308	118, 119, 120, 121, 122, 123, 124, 125, 126, 127, 128, 129, 130, 131, 132, 133, 134, 135, 136, 137, 138, 139, 140, 141, 142, 143, 144, 145, 146, 147, 148, 149, 150, 151, 152, 153, 154, 155, 156, 157, 158, 159, 160, 161, 162, 163, 164, 165, 166, 167, 168, 169, 170, 171, 172, 173, 174, 175, 176, 177, 178, 179, 180, 181, 182, 183, 184, 185, 186, 187, 188, 189, 190, 191, 192, 193, 194, 195, 196, 197, 198, 199, 200, 201, 202, 203, 204, 205, 206, 207, 208, 209, 210	ROCK ISLAND	210	3
STA.		TO STA.		
FED. ROAD DIST. NO. 2		ILLINOIS	FED. AID PROJECT	

- SEE CROSS SECTIONS FOR SPECIAL DITCHES AND BACKSLOPES.
- THE REMOVAL OF BITUMINOUS SURFACING NOT ON A RIGID TYPE BASE REMOVED IN CONJUNCTION WITH THE BASE SHALL BE REMOVED AS EARTH EXCAVATION. THE REMOVAL OF BITUMINOUS SURFACING ON A RIGID TYPE BASE REMOVED IN CONJUNCTION WITH THE BASE SHALL BE INCLUDED IN THE CONTRACT UNIT PRICE FOR PAVEMENT REMOVAL OR APPROACH SLAB REMOVAL OF THE TYPE SPECIFIED.
- THE FINAL TOP 100 MM (FOUR INCHES) OF SOIL IN ANY RIGHT-OF-WAY AREA DISTURBED BY THE CONTRACTOR MUST BE CAPABLE OF SUPPORTING VEGETATION. THE SOIL MUST BE FROM THE A HORIZON (ZERO TO 2' DEEP) OF SOIL PROFILES OF LOCAL SOILS.
- IT IS ESTIMATED THAT 2250 CUBIC YARDS OF EARTH WILL BE HAULED TO THE JOB FROM OUTSIDE THE PROJECT LIMITS. A SHRINKAGE FACTOR OF 25 % HAS BEEN USED.
- THE TOPSOIL EXCAVATION QUANTITIES HAVE BEEN ADJUSTED TO ALLOW FOR 25% SHRINKAGE OF TOPSOIL BETWEEN REMOVAL AND REPLACEMENT.
- THE CONTRACTOR SHALL SEED ALL DISTURBED AREAS WITHIN THE PROJECT LIMITS. SEEDING CLASS 4 OR 2A SHALL BE USED, EXCEPT IN FRONT OF PROPERTIES WHERE THE GRASS WILL BE MOWED, THEN USE SEEDING, CLASS 1. CLASS 2A SHALL BE USED ON FRONT SLOPES AND DITCH BOTTOMS. CLASS 4 SHALL BE USED BEHIND TYPE A GUTTER, ON ALL BACKSLOPES AND AREAS BEHIND THE BACKSLOPE, AND BEYOND THE TOE OF FRONT SLOPE ON FILL SECTIONS WITHOUT DITCHES.
- MULCH ON TEMPORARY SEEDING CLASS 7 SHALL BE MULCH METHOD 1.
- PREVIOUSLY PUGMILLED STOCKPILES OF "TYPE A" OLDER THAN 1 MONTH WILL NOT BE APPROVED FOR USE UNTIL A MOISTURE CHECK IS RUN TO VERIFY MOISTURE CONTENT. MATERIAL SHIPPED TO PROJECTS WITHOUT BEING TESTED WILL NOT BE ACCEPTED.
- THE FOLLOWING MIXTURE REQUIREMENTS ARE APPLICABLE FOR THIS PROJECT: EARTH WILL BE

MIXTURE USE(S):	SURFACE	LEVELING BINDER	SHOULDER SURFACE	SHOULDER BASE
PG:	PG 64-22	PG 64-22	PG 58-22	PG 58-22
DESIGN AIR VOIDS	4.0 @ N70	4.0 @ N70	3.0 @ N50	2.0 @ N50
MIXTURE COMPOSITION (GRADATION MIXTURE)	IL 9.5 or 12.5	IL 9.5	IL 9.5 or 12.5	BAM OR IL 19.0
FRICITION AGGREGATE	D	N/A	C	N/A
20 YEAR ESAL	5.8	5.8	N/A	N/A
MIX UNIT WEIGHT (LBS/SY/IN)	112	112	112	

- THE CONTRACTOR WILL BE REQUIRED TO FURNISH 140 MM (5 1/2") HIGH BRASS STENCILS AS APPROVED BY THE ENGINEER AND INSTALL STATIONING AT 250' INTERVALS. STATIONING SHALL BE PLACED ON BOTH LANES OF 2-LANE HIGHWAYS AND ON THE OUTSIDE LANES IN BOTH DIRECTIONS ON 4-LANE HIGHWAYS. THE STATIONS SHALL BE PLACED 150 MM (6") INSIDE THE PAVEMENT MARKING EDGE SO THEY CAN BE READ FROM THE SHOULDER. THIS WORK WILL BE INCLUDED IN THE COST OF THE FINAL PAVEMENT SURFACE.
- REFLECTIVE CRACK CONTROL SHALL BE PLACED ON THE EXISTING SURFACE PRIOR TO ANY RESURFACING, UNLESS PAVEMENT IS MILLED THEN IT WILL BE PLACED ON THE BINDER COURSE.
- INSTALL RUMBLE STRIPS IN ALL SHOULDERS IN ACCORDANCE WITH STATE STANDARD 642001. RUMBLE STRIPS SHALL BE PLACED ON SHOULDERS ON BOTH SIDES OF THE PAVEMENT.
- BITUMINOUS AND AGGREGATE PRIME COAT SHALL BE PLACED IN ACCORDANCE WITH SECTION 406 OF THE STANDARD SPECIFICATIONS. THE COST OF THE PRIME COATS SHALL BE INCLUDED IN THE CONTRACT UNIT PRICE PER METRIC TON (TON) FOR LEVELING BINDER (MACHINE METHOD) OF THE TYPE SPECIFIED.
- TEMPORARY TAPERS SHALL BE CONSTRUCTED ON ALL BRIDGES WHEN THE ADJACENT RESURFACING CANNOT BE PLACED BEFORE WINTER. QUANTITIES HAVE BEEN INCLUDED IN THE PLANS FOR A 1 TO 360 V/H (30' TO 1") TAPER ON INTERSTATE AND 1 TO 240 V/H (20' TO 1") TAPER ON ALL OTHER HIGHWAYS. THE TAPER SHALL BE REMOVED BEFORE RESURFACING AND WILL BE PAID FOR AS HOT-MIX ASPHALT SURFACE REMOVAL (VARIABLE DEPTH).

- THE STRUCTURE NUMBERS WILL BE:

	EXISTING	PROPOSED
SB FAP-308 (IL-92) OVER 31ST AVE	081-0065	081-0172
NB FAP-308 (IL-92) OVER 31ST AVE	081-0066	081-0173
FAP-308 (IL-92) OVER IAIS RR	081-0064	--
FAP-308 (IL-92) OVER 18TH AVE	081-0063	081-0171
FAP-308 (IL-92) OVER 7TH AVE	081-0062	081-0170

- THE CONTRACTOR SHALL SUBMIT FOUR COPIES OF THE REQUIRED SHOP DRAWINGS FOR REVIEW AND APPROVAL TO THE BUREAU OF BRIDGES AND STRUCTURES, 2300 SOUTH DIRKSEN PARKWAY, SPRINGFIELD, IL 62764. AFTER APPROVAL OF INITIAL SUBMITTAL, THE CONTRACTOR SHALL SUBMIT ONE SET OF SHOP DRAWINGS TO DAVE LIPPERT, ENGINEER OF MATERIALS, 126 EAST ASH STREET, SPRINGFIELD, IL 62706, AND EIGHT (8) SETS OF SHOP DRAWINGS TO BE DISTRIBUTED TO:

DISTRICT 2 REGIONAL ENGINEER (1)
 FABRICATOR (1)
 CONTRACTOR (2)
 RESIDENT ENGINEER (2)
 DISTRICT 2 BUREAU OF MATERIALS (2)

- THE REVIEW AND APPROVAL OF TEMPORARY SHEET PILING AND TEMPORARY SOIL RETENTION SYSTEM WILL REQUIRE 4 TO 6 WEEKS. THE CONTRACTOR SHALL SCHEDULE HIS WORK ACCORDINGLY.
- AT BRIDGE EXPANSION JOINTS, IF TEMPORARY EXPANSION JOINT BULKHEADS ARE ATTACHED TO ADJACENT DECK SLABS OR ABUTMENTS FOR SUPPORT, THE CONTRACTOR SHALL CUT THE ATTACHMENTS AS SOON AS THE CONCRETE HAS SET TO PREVENT JOINT DAMAGE DUE TO HORIZONTAL CONTRACTION OR EXPANSION.
- FOR THE BRIDGE OVER THE IAIS RR (S.N. 081-0064), THE CONTRACTOR SHALL SANDBLAST THE TOP OF THE BEAMS UPON REMOVAL OF THE BRIDGE DECK. THIS WORK WILL BE INCLUDED IN THE COST OF REMOVING THE BRIDGE DECK.
- THE CURB IS REQUIRED ON THE BRIDGE APPROACH PAVEMENT AS SHOWN ON STANDARD 420401.
- REFLECTOR MARKERS TYPE B SHALL BE INSTALLED ON THE FACE OF BRIDGE PARAPET WALLS. THE MARKERS SHALL BE ACCORDING TO STANDARD 635011 AND THE COLOR AND SPACING ACCORDING TO STANDARD 635006, EXCEPT THE MINIMUM IS 2 PER SIDE.
- ALL FRAMES AND GRATES OF DRAINAGE STRUCTURES TO BE REMOVED OR FILLED SHALL BE CAREFULLY SALVAGED AND SHALL REMAIN THE PROPERTY OF THE DEPARTMENT.

THE COST OF MAKING SEWER CONNECTIONS TO EXISTING DRAINAGE STRUCTURES SHALL BE INCLUDED IN THE VARIOUS CONTRACT UNIT PRICES FOR STORM SEWER.
- THE COST OF REMOVING EXISTING STORM SEWER DURING THE INSTALLATION OF NEW STORM SEWERS OR DRAINAGE STRUCTURES SHALL BE INCLUDED IN THE CONTRACT UNIT PRICE FOR THE STORM SEWER OR DRAINAGE STRUCTURE BEING INSTALLED.
- ALL DRAINAGE STRUCTURES ARE OFFSET 0.0' FROM THE CENTERLINE OF IL-92 AS MEASURED TO THE CENTER OF THE STRUCTURE UNLESS OTHERWISE SHOWN ON THE PLANS. FRAMES AND GRATES ARE SHOWN ON THE INLET SIDE OF THE MEDIAN BARRIER. RIM ELEVATIONS ARE TO THE HIGH SIDE OF THE FRAME AND GRATE.

- THE CONTRACTOR SHALL DETERMINE FLOWLINES OF EXISTING SEWER LINES WHICH ARE SHOWN ON THE PLANS AS ESTIMATED OR UNKNOWN. THIS INFORMATION IS NECESSARY BEFORE ORDERING DRAINAGE STRUCTURES.
- A QUANTITY OF 482 CUBIC YARDS OF FURNISH EXCAVATION HAS BEEN INCLUDED TO FURTHER BUILD UP THE SHOULDERS, IF THE ENGINEER DETERMINES THAT THE EXCAVATED MATERIALS FROM THE JOB ARE INSUFFICIENT TO BRING THE SHOULDERS TO THE PROPER SLOPE.
- THE MILLINGS FROM HOT-MIX ASPHALT SURFACE REMOVAL SHALL BE USED TO BUILD UP THE EXISTING SHOULDERS, AS SHOWN ON THE TYPICAL SECTIONS AND/OR AS DIRECTED BY THE ENGINEER. THE SHOULDER SHALL BE ROLLED AND COMPACTED AS DIRECTED BY THE ENGINEER. EXCESS GRINDINGS OR LARGE CHUNKS SHALL BE DISPOSED OF BY THE CONTRACTOR. NO GRINDINGS WILL BE ALLOWED ON THE FORESLOPES. THE COST SHALL BE INCLUDED IN THE CONTRACT UNIT PRICE FOR THE HOT-MIX ASPHALT SURFACE REMOVAL (VARIABLE DEPTH) SPECIFIED.
- EMBANKMENT QUANTITIES FOR THE CONSTRUCTION OF THE TRAFFIC BARRIER TERMINALS AS SHOWN IN THE PLANS ARE INCLUDED IN QUANTITIES FOR FURNISHED EXCAVATION.
- THE CONTRACTOR SHALL SUPPLY THE RESIDENT ENGINEER WITH THE MANUFACTURER'S INSTALLATION REQUIREMENTS FOR THE TYPE OF STEEL PLATE BEAM GUARDRAIL TERMINAL TYPE 1 SPECIAL (TANGENT) OR STEEL PLATE BEAM GUARDRAIL TERMINAL TYPE I SPECIAL (FLARED).
- ONE 16D GALVANIZED NAIL SHALL BE USED TO TOE NAIL THE WOOD BLOCK OUT TO THE WOOD POST ON ALL TRAFFIC BARRIER TERMINAL TYPE I SPECIALS.
- DELINEATORS SHALL BE INSTALLED AS SHOWN IN STANDARD 635001, EXCEPT THAT THE POST SHALL BE ROTATED 180° AND ONLY METAL-BACKED DELINEATORS SHALL BE PERMITTED.
- DELINEATORS SHALL BE PLACED AT THE ENDS OF APPROACH GUARDRAIL TERMINAL SECTIONS. THIS WORK WILL BE PAID FOR AT THE CONTRACT UNIT PRICE EACH FOR DELINEATORS.
- PAVEMENT MARKING SHALL BE DONE ACCORDING TO STANDARD 780001, EXCEPT AS FOLLOWS:
 - ALL WORDS, SUCH AS ONLY, SHALL BE 2.4 M (8 FEET) HIGH.
 - ALL NON-FREEWAY ARROWS SHALL BE THE LARGE SIZE.
 - THE DISTANCE BETWEEN YELLOW NO-PASSING LINES SHALL BE 200 MM (8"), NOT 180 MM (7") AS SHOWN IN THE DETAIL OF TYPICAL LANE AND EDGE LINES.
- SURVEY MARKERS
- PERMANENT SURVEY MARKERS, TYPE II, SHALL BE SET AT AS DIRECTED BY THE ENGINEER. ONE SURVEY MARKER PLACED NEAR THE STRUCTURE ESTIMATED: 4 EACH.
- PERMANENT SURVEY MARKERS, TYPE II SHALL BE CAST-IN-PLACE AS SHOWN ON HIGHWAY STANDARD 667101.
- THE CONTRACTOR SHALL SUBMIT TO THE ENGINEER A DESCRIPTION OF LOCATION, ELEVATION, AND COORDINATES FOR EACH PERMANENT SURVEY MARKER. THE ENGINEER SHALL SUBMIT THIS INFORMATION TO THE SURVEY CREW.
- IMPACT ATTENUATORS, TEMPORARY (NON-REDIRECTIVE), TEST LEVEL 3 SHALL BE ENERGY ABSORPTION SYSTEMS, INC. ABSORB 350 AT ALL LOCATIONS WHERE THERE ARE INSUFFICIENT CLEARANCES FOR BARREL-BASED SYSTEMS.

PLOT DATE = DATE
 FILE NAME = SHEETS
 USER NAME = USER

REVISIONS		ILLINOIS DEPARTMENT OF TRANSPORTATION
NAME	DATE	
		SCALE: NONE DATE
DRAWN BY	AMK	CHECKED BY
	MGZ	

GENERAL NOTES

F.A.P. RTE.	SECTION	COUNTY	TOTAL SHEETS	SHEET NO.
	10810-1.0610-2R	ROCK ISLAND	210	4
STA.		TO STA.		
FED. ROAD DIST. NO. 2		ILLINOIS	FED. AID PROJECT	

UTILITIES

38. THE CONTRACTOR SHALL BE RESPONSIBLE FOR PROTECTING UTILITY PROPERTY DURING CONSTRUCTION OPERATIONS AS OUTLINED IN ARTICLE 107.31 OF THE STANDARD SPECIFICATIONS. A MINIMUM OF 48 HOURS ADVANCE NOTICE IS REQUIRED FOR NON-EMERGENCY WORK. THE JULIE NUMBER IS 800-892-0123. THE FOLLOWING LISTED UTILITIES LOCATED WITHIN THE PROJECT LIMITS OR IMMEDIATELY ADJACENT TO THE PROJECT CONSTRUCTION LIMITS ARE MEMBERS OF JULIE:

- SBC AMERITECH TELEPHONE CO.
- CITY OF ROCK ISLAND
- MIDAMERICAN ENERGY CO.
- MEDIACOM
- MCI WORLD COM

39. FOLLOWING ARE THE KNOWN UTILITIES LOCATED WITHIN THE PROJECT LIMITS OR IMMEDIATELY ADJACENT TO THE PROJECT CONSTRUCTION LIMITS WHICH ARE NOT MEMBERS OF JULIE AND SHOULD BE NOTIFIED INDIVIDUALLY BY THE CONTRACTOR:

- KYLE LORENZ
- IDOT - DISTRICT 2
- 819 DEPOT AVENUE
- DIXON, IL 21021
- (815) 284-5469

40. CADD DATA WILL BE AVAILABLE TO CONTRACTORS AND CONSULTANTS WORKING ON THIS PROJECT. THIS INFORMATION WILL BE PROVIDED UPON REQUEST AS MICROSTATION CADD FILES AND GEOPAK COORDINATE GEOMETRY FILES ONLY. IF DATA IS REQUIRED IN OTHER FORMATS IT WILL BE THE CONTRACTOR OR CONSULTANT'S RESPONSIBILITY TO MAKE THESE CONVERSIONS. IF ANY DISCREPANCY OR INCONSISTENCY ARISES BETWEEN THE ELECTRONIC DATA AND THE INFORMATION ON THE HARD COPY, THE INFORMATION ON THE HARD COPY SHOULD BE USED. CONTACT THE DISTRICT'S PROJECT ENGINEER TO REQUEST THESE FILES.

41. HEIGHT AND WIDTH OF MEDIAN BARRIER SHALL TRANSITION FROM ROADWAY TO BRIDGE SECTIONS OVER A DISTANCE OF 10'. THE TRANSITION SHALL OCCUR ON THE ROADWAY SECTION ADJACENT TO THE APPROACH PAVEMENT AT EACH LOCATION.

42. IMPACT ATTENUATORS, TEMPORARY (NON-REDIRECTIVE), TEST LEVEL 3 SHALL BE ABSORB 350

COMMITMENTS

1. NO TREES WILL BE REMOVED DURING THIS PROJECT CONSTRUCTION
2. THERE ARE SEVERAL WETLANDS IN THE PROJECT AREA WHICH ARE SHOWN ON THE CONTRACT PLANS. NO CONSTRUCTION ACTIVITIES, INCLUDING EQUIPMENT AND MATERIAL STORAGE, OR DRIVING OF VEHICLES AND EQUIPMENT SHALL TAKE PLACE BEYOND THE CONSTRUCTION LIMITS SHOWN ON THE CONTRACT PLANS SO AS TO AVOID ANY WETLAND IMPACTS. WETLANDS CAN BE FOUND ON EROSION AND SEDIMENT CONTROL SHEETS 68-75.

DATE
 SCALE
 USER

REVISIONS		ILLINOIS DEPARTMENT OF TRANSPORTATION
NAME	DATE	
		SCALE: NONE DATE:
DRAWN BY AMK		CHECKED BY MGZ

F.A.P. SECTION	COUNTY	TOTAL SHEETS	SHEET NO.
308 INHJH-LVBJH-2R	ROCK ISLAND	210	5
STA. TO STA.		FED. AID PROJECT	
FED. ROAD DIST. NO. 2		ILLINOIS	

SUMMARY OF QUANTITIES

CODE NUMBER	ITEM	URBAN 80% FED. 20% STATE		BRF ROADWAY BITUMINOUS 1000	BRF ROADWAY CONCRETE J000	BRF BRIDGE 31ST SB X271-2A	BRF BRIDGE 31ST NB X271-2A	BRF BRIDGE RR X171 2A	BRF BRIDGE 18TH X271-2A	BRF BRIDGE 7TH X271-2A	BRF GUARDRAIL SFTY-3J	BRF LIGHTING Y030-1E
		UNITS	TOTAL									
25000400	NITROGEN FERTILIZER NUTRIENT	POUND	475	475								
25000500	PHOSPHORUS FERTILIZER NUTRIENT	POUND	475	475								
25000600	POTASSIUM FERTILIZER NUTRIENT	POUND	475	475								
20200100	EARTH EXCAVATION	CU YD	83	83								
20400800	FURNISHED EXCAVATION	CU YD	2250	2250								
20700400	POROUS GRANULAR EMBANKMENT, SPECIAL	CU YD	1252			138	138	348	310	318		
20800150	TRENCH BACKFILL	CU YD	193.8	193.8								
21101505	TOPSOIL EXCAVATION AND PLACEMENT	CU YD	991	991								
21400100	GRADING AND SHAPING DITCHES	FOOT	100	100								
25000210	SEEDING, CLASS 2A	ACRE	5.3	5.3								
25000750	MOWING	ACRE	5.3	5.3								
28000700	MULCH, METHOD 1	ACRE	21.2	21.2								
25100115	MULCH, METHOD 2	ACRE	5.3	5.3								
25100630	EROSION CONTROL BLANKET	SQ YD	25525	25525								
28000250	TEMPORARY EROSION CONTROL SEEDING	POUND	2112	2112								
28000400	PERIMETER EROSION BARRIER	FOOT	9955	9955								
28000500	INLET AND PIPE PROTECTION	EACH	39	39								
28100125	STONE RIPRAP, CLASS B3	SQ YD	134	134								
31100300	SUB-BASE GRANULAR MATERIAL, TYPE A 4"	SQ YD	5960	5960								
40600635	LEVELING BINDER (MACHINE METHOD), N70	TON	91	91								
40603310	HOT-MIX ASPHALT SURFACE COURSE, MIX "C", N50	TON	1015	1015								
40603340	HOT-MIX ASPHALT SURFACE COURSE, MIX "D", N70	TON	567	567								
42000501	PORTLAND CEMENT CONCRETE PAVEMENT 10" (JOINTED)	SQ YD	108		108							
42000520	PORTLAND CEMENT CONCRETE PAVEMENT 11"	SQ YD	5714		5714							
42001165	BRIDGE APPROACH PAVEMENT	SQ YD	2129		2129							
42001420	BRIDGE APPROACH PAVEMENT CONNECTOR (PCC)	SQ YD	444		444							
42101300	PROTECTIVE COAT	SQ YD	14168		14168							
44000100	PAVEMENT REMOVAL	SQ YD	108		108							
44000155	HOT-MIX ASPHALT SURFACE COURSE REMOVAL, 1 1/2"	SQ YD	1255	1255								
44000198	HOT-MIX ASPHALT SURFACE REMOVAL, VARIABLE DEPTH	SQ YD	5489	5489								
44000500	COMBINATION CURB AND GUTTER REMOVAL	FOOT	418		418							
44000700	APPROACH SLAB REMOVAL	SQ YD	2116		2116							
44004250	PAVED SHOULDER REMOVAL	SQ YD	12605	12605								
44200571	CLASS A PATCHES, TYPE IV, 11 INCH	SQ YD	691		691							
48101200	AGGREGATE SHOULDERS, TYPE B	TON	178	178								
48203023	HOT-MIX ASPHALT SHOULDERS, 6 1/2"	SQ YD	12067	12067								
50100300	REMOVAL OF EXISTING STRUCTURES NO. 1	EACH	1						1			
50100400	REMOVAL OF EXISTING STRUCTURES NO. 2	EACH	1						1			

●

REVISIONS		ILLINOIS DEPARTMENT OF TRANSPORTATION
NAME	DATE	
		SCALE: NONE DATE

DRAWN BY AMK
CHECKED BY MGZ

● NON-PARTICIPATING (100% STATE)

SUMMARY OF QUANTITIES

PLOT DATE * DATE *
FILE NAME * FILE *
USER NAME * USER *

F.A.P. RTE.	SECTION	COUNTY	TOTAL SHEETS	SHEET NO.
30B	10B,16-1,16B,21R	ROCK ISLAND	210	64
STA.	TO STA.			
FED. ROAD DIST. NO. 2		ILLINOIS	FED. AID PROJECT	

SUMMARY OF QUANTITIES

CODE NUMBER	ITEM	URBAN 80% FED. 20% STATE	TOTAL	BRF ROADWAY BITUMINOUS 1000	BRF ROADWAY CONCRETE 1000	BRF BRIDGE 31ST SB X271-2A	BHF BRIDGE 31ST NB X271-2A	BHF BRIDGE RR X171-2A	BRF BRIDGE 18TH X271-2A	BRF BRIDGE 7TH X271-2A	BRF GUARDRAIL SFTY-3J	BRF LIGHTING Y030-1E
55100500	STORM SEWER REMOVAL 12"	FOOT	74	74								
58700300	CONCRETE SEALER	SQ FT	17407			3252	3238	1453	5042	4422		
59100100	GEOCOMPOSITE WALL DRAIN	SQ YD	656			86	85	211	138	136		
60100060	CONCRETE HEADWALL FOR PIPE DRAINS	EACH	20	20								
60100945	PIPE DRAINS 12"	FOOT	490	490								
60109580	PIPE UNDERDRAINS FOR STRUCTURES 4"	FOOT	2130			170	170	1018	224	548		
60500050	REMOVING CATCH BASINS	EACH	15	15								
60500205	FILLING CATCH BASINS	EACH	8	8								
60605000	COMBINATION CONCRETE CURB AND GUTTER, TYPE B-6.24	FOOT	350		350							
60900315	TYPE D INLET BOX, STANDARD 609006	EACH	10	10								
60900515	CONCRETE THRUST BLOCKS	EACH	10	10								
* 63000000	STEEL PLATE BEAM GUARD RAIL, TYPE A	FOOT	7400								7400	
* 63000005	STEEL PLATE BEAM GUARD RAIL, TYPE B	FOOT	250								250	
* 63000015	STEEL PLATE BEAM GUARD RAIL, TYPE D	FOOT	312.5								312.5	
* 63100045	TRAFFIC BARRIER TERMINAL, TYPE 2	EACH	5								5	
* 63100070	TRAFFIC BARRIER TERMINAL, TYPE 5	EACH	4								4	
* 63100085	TRAFFIC BARRIER TERMINAL, TYPE 6	EACH	10								10	
* 63100089	TRAFFIC BARRIER TERMINAL, TYPE 6B	EACH	2								2	
* 63100167	TRAFFIC BARRIER TERMINAL, TYPE 1 (SPECIAL) TANGENT	EACH	11								11	
63200310	GUARDRAIL REMOVAL	FOOT	6930								6930	
63500105	DELINEATORS	EACH	13	13								
63700255	CONCRETE BARRIER, DOUBLE FACE, 32 INCH HEIGHT	FOOT	6856	6856								
63801205	TEMPORARY MODULAR GLARE SCREEN	FOOT	1150	1150								
66700305	PERMANENT SURVEY MARKERS, TYPE II	EACH	4	4								
67000400	ENGINEER'S FIELD OFFICE, TYPE A	CALMO	18	18								
67000600	ENGINEER'S FIELD LABORATORY	CALMO	18	18								
67100100	MOBILIZATION	L SUM	1	1								
70100207	TRAFFIC CONTROL AND PROTECTION, STANDARD 701402	EACH	3	3								
70100410	TRAFFIC CONTROL AND PROTECTION, STANDARD 701416	EACH	2	2								
70100420	TRAFFIC CONTROL AND PROTECTION, STANDARD 701411	EACH	3	3								
70100800	TRAFFIC CONTROL AND PROTECTION, STANDARD 701401	L SUM	1	1								
70101800	TRAFFIC CONTROL AND PROTECTION, (SPECIAL)	L SUM	1	1								
70102625	TRAFFIC CONTROL AND PROTECTION, STANDARD 701606	L SUM	1	1								
70103815	TRAFFIC CONTROL SURVEILLANCE	CAL DA	518	518								
70300100	SHORT-TERM PAVEMENT MARKING	FOOT	1524	1524								
70300220	TEMPORARY PAVEMENT MARKING - LINE 4"	FOOT	197612	197612								
70301000	WORK ZONE PAVEMENT MARKING REMOVAL	SQ FT	65864	65864								
70400100	TEMPORARY CONCRETE BARRIER	FOOT	24711	24711								
70400200	RELOCATE TEMPORARY CONCRETE BARRIER	FOOT	28216	28216								

REVISIONS		ILLINOIS DEPARTMENT OF TRANSPORTATION
NAME	DATE	
		SCALE: NONE DATE
DRAWN BY AMK		CHECKED BY MGZ
DATE		

PLOT DATE * DATE *
 PLOT SCALE * SCALE *
 PLOT NAME * USER *
 USER NAME * USER *

F.A.P. RTE.	SECTION	COUNTY	TOTAL SHEETS	SHEET NO.
308	1B8,HB-1,VB,HB-2R	ROCK ISLAND	210	63
STA.		TO STA.		
FED. ROAD DIST. NO. 2		ILLINOIS	FED. AID PROJECT	

SUMMARY OF QUANTITIES

CODE NUMBER	ITEM	URBAN 80% FED. 20% STATE UNITS	TOTAL	BRF ROADWAY BITUMINOUS 1000	BRF ROADWAY CONCRETE 1000	BRF BRIDGE 31ST SB X271-2A	BHF BRIDGE 31ST NB X271-2A	BHF BRIDGE RR X171-2A	BRF BRIDGE 18TH X271-2A	BRF BRIDGE 7TH X271-2A	BRF GUARDRAIL SFTY-3J	BRF LIGHTING Y030-1E
70500100	TEMPORARY STEEL PLATE BEAM GUARD RAIL, TYPE A	FOOT	525	525								
* 78001110	PAINT PAVEMENT MARKING - LINE 4"	FOOT	122748	122748								
* 78001140	PAINT PAVEMENT MARKING - LINE 8"	FOOT	10623	10623								
* 78001150	PAINT PAVEMENT MARKING - LINE 12"	FOOT	2055	2055								
* 78200410	GUARDRAIL MARKERS, TYPE A	EACH	66	66								
* 78200420	GUARDRAIL MARKERS, TYPE B	EACH	30	30								
* 78201000	TERMINAL MARKER - DIRECT APPLIED	EACH	13	13								
78300100	PAVEMENT MARKING REMOVAL	SQ FT	23743	23743								
* 81018500	CONDUIT PUSHED, 2" DIA., GALVANIZED STEEL	FOOT	470									470
* 81100300	CONDUIT ATTACHED TO STRUCTURE, 1" DIA., ^{STEEL} GALVANIZED	FOOT	380									380
* 81300220	JUNCTION BOX, STAINLESS STEEL, ATTACHED TO STRUCTURE, 6" X 6" X 4"	EACH	6									6
* 81300530	JUNCTION BOX, STAINLESS STEEL, ATTACHED TO STRUCTURE, 12" X 10" X 6"	EACH	4									4
* 81300730	JUNCTION BOX, STAINLESS STEEL, ATTACHED TO STRUCTURE, 16" X 14" X 6"	EACH	4									4
* 81306500	REMOVE EXISTING JUNCTION BOX	EACH	8									8
* 81603010	UNIT DUCT, 600V, 2-1C NO.10, 1/C NO.10 GROUND, (XLP-TYPE USE), 3/4" DIA. POLYETHYLENE	FOOT	420									420
* 81603040	UNIT DUCT, 600V, 2-1C NO.6, 1/C NO.8 GROUND, (XLP-TYPE USE), 1" DIA. POLYETHYLENE	FOOT	1930									1930
* 81800230	AERIAL CABLE, 2-1/C NO. 6 WITH MESSENGER WIRE	FOOT	1760									1760
* 81900200	TRENCH AND BACKFILL FOR ELECTRICAL WORK	FOOT	1000									1000
* 82107300	UNDERPASS LUMINAIRE, 150 WATT, HIGH PRESSURE SODIUM VAPOR	EACH	8									8
* 83057340	LIGHT POLE, WOOD, 60 FOOT, CLASS 3	EACH	5									5
84100110	REMOVAL OF TEMPORARY LIGHTING UNITS	EACH	5									5
84200600	REMOVAL OF EXISTING LIGHTING UNIT, NO SALVAGE	EACH	4									4
X0301766	DRILL AND GROUT #6 TIE BARS	EACH	47	47								
X0320870	BRACED EXCAVATION	CU YD	714						714			
X0322288	MEDIAN CLOSURE	EACH	1	1								
X0323830	DRAINAGE SCUPPERS, DS-11	EACH	22				6		8	8		
X0323988	TEMPORARY SOIL RETENTION SYSTEM	SQ FT	284						160	124		
Z0048665	RAILROAD PROTECTIVE LIABILITY INSURANCE	L SUM	1	1								
* X0325110	BIAXIAL GEOGRID	SQ YD	5714	5714								
X0325303	STRUCTURAL REPAIR OF CONCRETE (DEPTH GREATER THAN 5 INCHES)	SQ FT	50					50				
X0325305	STRUCTURAL REPAIR OF CONCRETE (DEPTH EQUAL TO OR LESS THAN 5 INCHES)	SQ FT	474					474				
● X2503000	MAINTENANCE MOWING	ACRE	62	62								
X6370150	CONCRETE BARRIER, VARIABLE CROSS-SECTION 32" HEIGHT	FOOT	60	60								
X7050167	TEMPORARY TRAFFIC BARRIER TERMINAL, TYPE 1, SPECIAL (TANGENT)	EACH	2	2								
81100600	CONDUIT ATTACHED TO STRUCTURE, 2" DIA, GALVANIZED STEEL	FOOT	210									210
XX005713	ORNAMENTAL RAILING	FOOT	1373			241	241	441	225	225		
XX005808	MEDIAN REMOVAL (SPECIAL)	SQ YD	3149	3149								
XX005817	FORM LINER LIMESTONE SURFACE	SQ FT	4670			1467	1446		1757			

●NON-PARTICIPATING (100% STATE)

REVISIONS		ILLINOIS DEPARTMENT OF TRANSPORTATION
NAME	DATE	

SCALE: NONE
DATE: _____

DRAWN BY: AMK
CHECKED BY: MGZ

PLOT DATE: * * * * *
FILE NAME: * * * * *
PLOT SCALE: * * * * *
USER NAME: * * * * *

F.A.P. RTE.	SECTION	COUNTY	TOTAL SHEETS	SHEET NO.
308	18B,18-1,18B,18-2R	ROCK ISLAND	210	6C
STA.		TO STA.		
FED. ROAD DIST. NO. 2		ILLINOIS FED. AID PROJECT		

SUMMARY OF QUANTITIES

CODE NUMBER	ITEM	URBAN	TOTAL	BRF	BRF	BRF	BHF	BHF	BRF	BRF	BRF	BRF
		80% FED. 20% STATE		ROADWAY BITUMINOUS 1000	ROADWAY CONCRETE 1000	BRIDGE 31ST SB X271-2A	BRIDGE 31ST NB X271-2A	BRIDGE RR X171-2A	BRIDGE 18TH X271-2A	BRIDGE 7TH X271-2A	GUARDRAIL SFTY-3J	LIGHTING YO30-1E
UNITS												
Z0013798	CONSTRUCTION LAYOUT	L SUM	1	1								
Z0014700	CULVERT TO BE CLEANED	EACH	10	10								
Z0018800	DRAINAGE SYSTEM	L SUM	1				0.4	0.3	0.3			
Z0018900	DRILL AND GROUT DOWEL BARS	EACH	199	199								
Z0030240	IMPACT ATTENUATORS, TEMPORARY (NON-REDIRECTIVE), TEST LEVEL 2	EACH	12	12								
Z0030250	IMPACT ATTENUATORS, TEMPORARY (NON-REDIRECTIVE), TEST LEVEL 3	EACH	5	5								
Z0030350	IMPACT ATTENUATORS, RELOCATE (NON-REDIRECTIVE), TEST LEVEL 3	EACH	4	4								
X0320801	DRAINAGE STRUCTURE TYPE 1(SPECIAL)	EACH	21	21								
X0325932	DRAINAGE STRUCTURE TYPE 2(SPECIAL)	EACH	5	5								
X0325933	REMOVE MEDIAN CLOSURE	EACH	1	1								
X0325934	TEXTURED SLOPEWALL	SO YD	2182			496.5	496.5		587	602		
70500670	TEMPORARY TRAFFIC BARRIER TERMINAL, TYPE 6A	EACH	2	2								

NON-PARTICIPATING (100% STATE)

PLOT DATE * DATE *
FILE NAME * SCALE *
USER NAME * USERID

REVISIONS	
NAME	DATE

ILLINOIS DEPARTMENT OF TRANSPORTATION

SCALE: NONE
DATE

DRAWN BY AMK
CHECKED BY MGZ

F.A.P. RTE.	SECTION	COUNTY	TOTAL SHEETS	SHEET NO.
308	1184B-1VB4B-2R	ROCK ISLAND	210	7
STA.		TO STA.		
FED. ROAD DIST. NO. 2		ILLINOIS FED. AID PROJECT		

TYPICAL SECTIONS

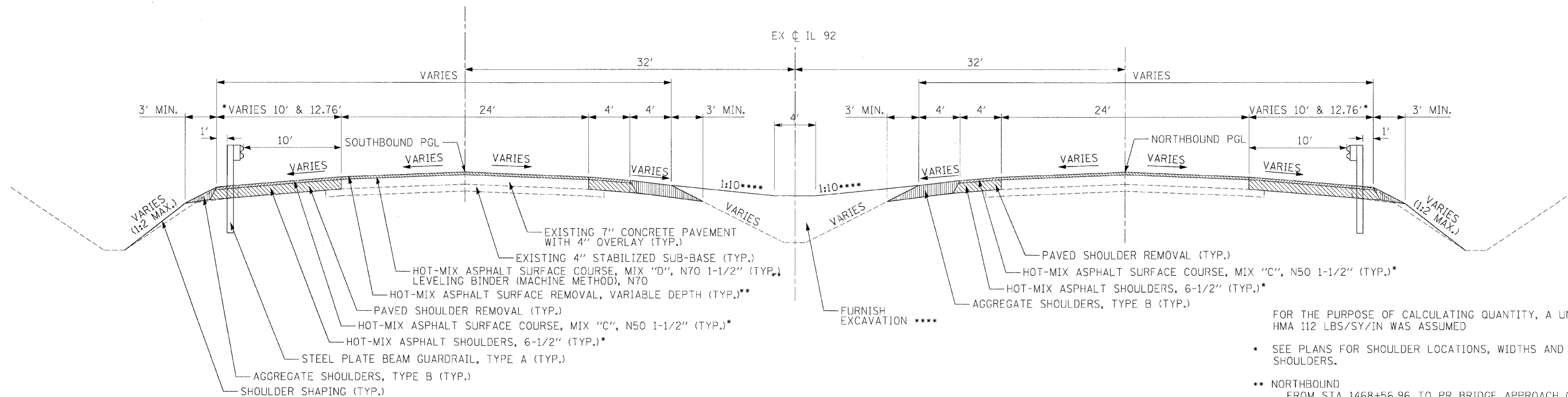
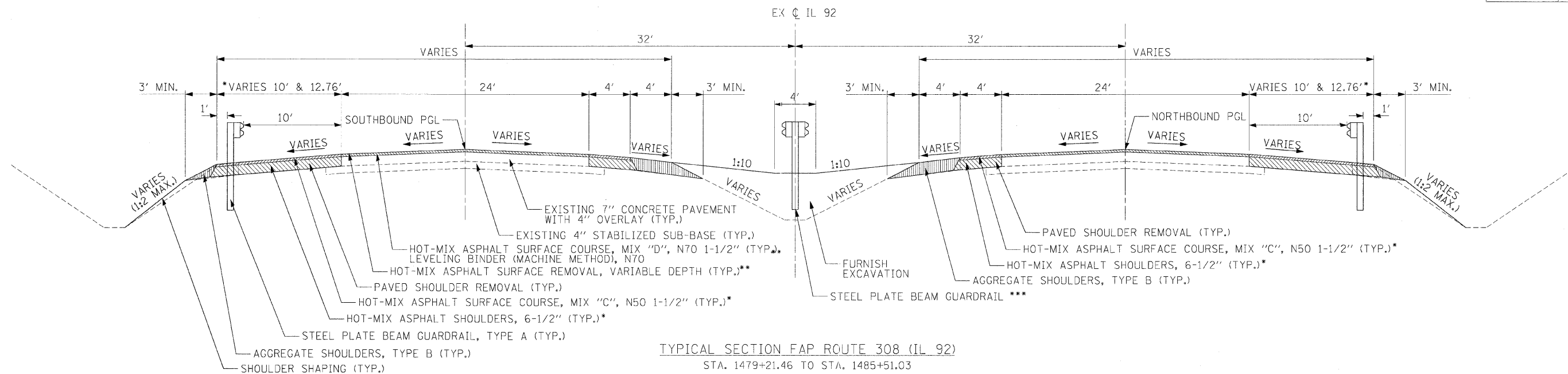

TYPICAL SECTION FAP ROUTE 308 (IL 92)
 NORTHBOUND IL 92
 STA 1463+87.27 TO STA 1469+91.81 NB IL 92
 BRIDGE OMISSION STA 1469+91.81 TO STA 1471+19.47 - 31ST AVE
 STA 1471+40.00 TO STA 1479+21.46
 SOUTHBOUND IL 92
 STA 1466+51.56 TO STA 1470+21.15
 BRIDGE OMISSION STA 1470+21.15 TO STA 1471+48.82 - 31ST AVE
 STA 1471+40.00 TO STA 1479+21.46

FOR THE PURPOSE OF CALCULATING QUANTITY, A UNIT WEIGHT OF HMA 112 LBS/SY/IN WAS ASSUMED

* SEE PLANS FOR SHOULDER LOCATIONS, WIDTHS AND TRANSITIONS OF SHOULDER.

** NORTHBOUND
 FROM STA 1468+56.96 TO PR BRIDGE APPROACH CONNECTOR PAVEMENT
 FROM STA PR BRIDGE APPROACH CONNECTOR PAVEMENT TO STA 1472+55.85

SOUTHBOUND
 FROM STA 1468+84.48 TO PR BRIDGE APPROACH CONNECTOR PAVEMENT
 FROM STA PR BRIDGE APPROACH CONNECTOR PAVEMENT TO STA 1472+83.28

*** TYPE A FROM STA. 1471+21.46 TO 1481+71.14
 TYPE D FROM STA. 1481+71.14 TO 1485+51.03

**** REGRADING FOR GUARDRAIL INSTALLATION
 FROM STA. 1467+00.00 TO STA. 1470+06.00
 FROM STA. 1471+30.00 TO STA. 1474+50.00

REVISIONS		ILLINOIS DEPARTMENT OF TRANSPORTATION
NAME	DATE	
		TYPICAL SECTION FAP ROUTE 308 (IL 92)

SCALE: N.T.S. DRAWN BY: TLL
 DATE: 12/8/06 CHECKED BY: MGZ

DATE = #DATE#
 FILE NAME = #FILE#
 PLOT SCALE = #SCALE#
 USER NAME = #USER#

F.A.P. RTE.	SECTION	COUNTY	TOTAL SHEETS	SHEET NO.
308	118B+1-VB+1B-2R	ROCK ISLAND	210	8
STA.		TO STA.		
FED. ROAD DIST. NO. 2		ILLINOIS FED. AID PROJECT		

TYPICAL SECTIONS

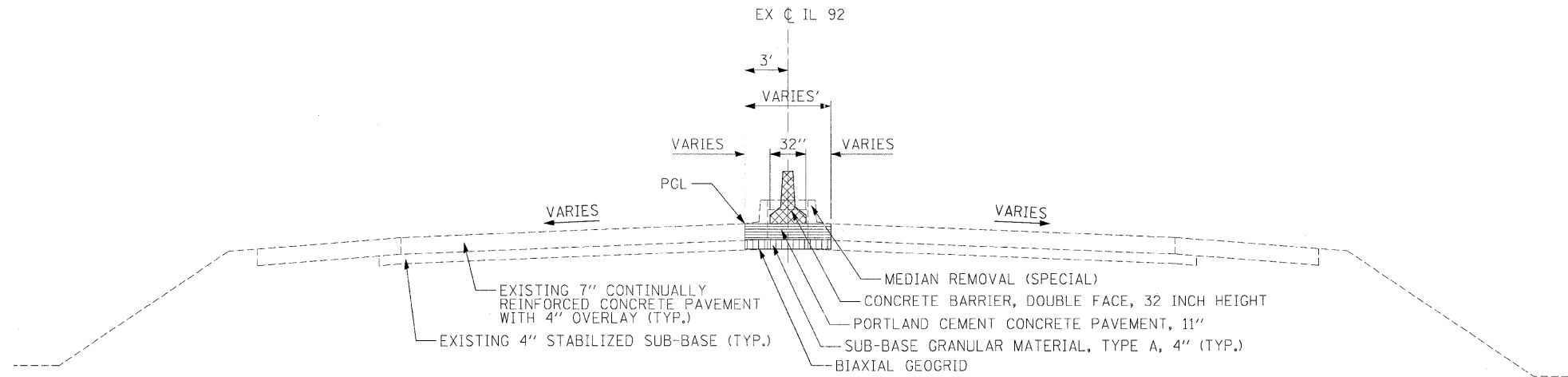

TYPICAL SECTION FAP ROUTE 308 (IL 92)

STA 1485+51.03 TO STA 1498+26.37
 STA 1521+87.19 TO STA 1543+07.55
 STA 1551+33.15 TO STA 1561+63.55 (END PROJECT)

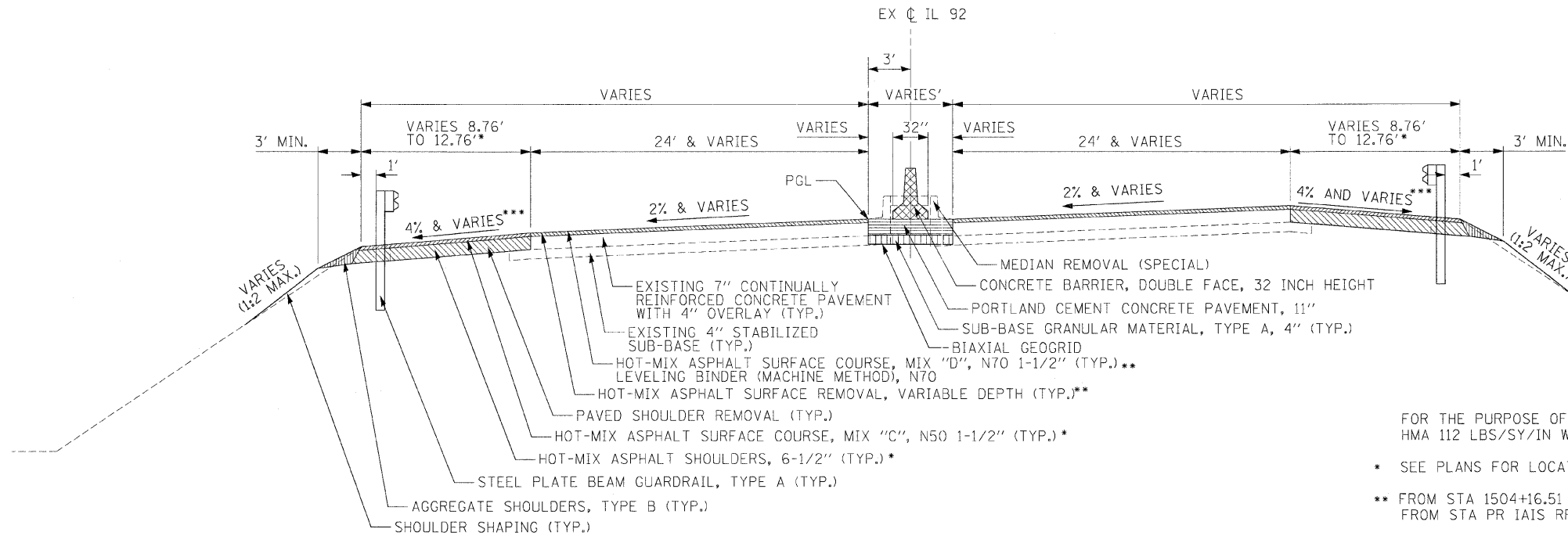

TYPICAL SECTION FAP ROUTE 308 (IL 92)

STA 1498+26.37 TO STA 1505+64.11
 BRIDGE OMISSION STA 1505+64.11 TO STA 1508+52.94 - IAIS RR
 STA 1508+52.94 TO STA 1516+88.60
 BRIDGE OMISSION STA 1516+88.60 TO STA 1518+66.29 - 18TH AVE
 STA 1518+66.29 TO STA 1521+87.19

FOR THE PURPOSE OF CALCULATING QUANTITY, A UNIT WEIGHT OF HMA 112 LBS/SY/IN WAS ASSUMED

- * SEE PLANS FOR LOCATIONS, WIDTHS AND TRANSITIONS OF SHOULDERS
- ** FROM STA 1504+16.51 TO PR IAIS RR BRIDGE APPROACH CONNECTOR PAVEMENT
 FROM STA PR IAIS RR BRIDGE APPROACH CONNECTOR PAVEMENT TO STA 1510+00.00
 FROM STA 1515+65.53 TO PR 18TH AVE. BRIDGE APPROACH CONNECTOR PAVEMENT
 FROM STA PR 18TH AVE BRIDGE APPROACH CONNECTOR PAVEMENT TO STA 1521+56.81
- *** SHOULDER SLOPE TRANSITIONS TO 2% SUPERELEVATION PRIOR TO PR BRIDGE APPROACH PAVEMENT

THE UNIT WEIGHT OF THE HMA IS 112 LBS/SY/IN

REVISIONS	
NAME	DATE

ILLINOIS DEPARTMENT OF TRANSPORTATION

TYPICAL SECTION
 FAP ROUTE 308 (IL 92)

SCALE: N.T.S.
 DATE: 12/8/06

DRAWN BY: TLL
 CHECKED BY: MGZ

PLOT DATE = \$DATE\$
 FILE NAME = \$FILE\$
 PLOT SCALE = \$SCALE\$
 USER NAME = \$USER\$

F.A.P. RTE.	SECTION	COUNTY	TOTAL SHEETS	SHEET NO.
308	116B-1,VB-2R	ROCK ISLAND	210	9
STA.		TO STA.		
FED. ROAD DIST. NO. 2		ILLINOIS FED. AID PROJECT		

TYPICAL SECTIONS

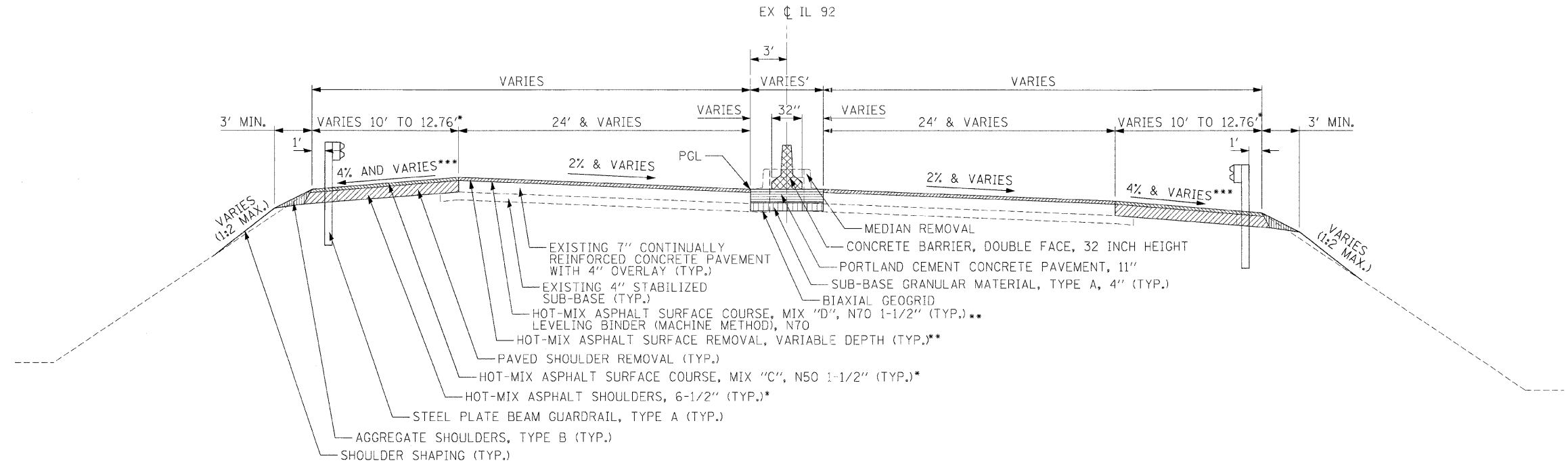

TYPICAL SECTION FAP ROUTE 308 (IL 92)
 STA 1543+07.55 TO STA 1546+33.21
 BRIDGE OMISSION STA 1546+33.21 TO STA 1548+11.90
 STA 1548+11.90 TO STA 1551+33.15

- FOR THE PURPOSE OF CALCULATING QUANTITY, A UNIT WEIGHT OF HMA 112 LBS/SY/IN WAS ASSUMED
- * SEE PLANS FOR LOCATIONS, WIDTHS AND TRANSITIONS OF SHOULDERS
 - ** FROM STA 1545+27.29 TO PR BRIDGE APPROACH CONNECTOR PAVEMENT FROM STA PR BRIDGE APPROACH CONNECTOR PAVEMENT TO STA 1549+17.98
 - *** SHOULDER SLOPE TRANSITIONS TO 2% SUPERELEVATION PRIOR TO PR BRIDGE APPROACH PAVEMENT
- THE UNIT WEIGHT OF THE HMA IS 112 LBS/SY/IN

REVISIONS		ILLINOIS DEPARTMENT OF TRANSPORTATION
NAME	DATE	
		TYPICAL SECTION FAP ROUTE 308 (IL 92)

SCALE: N.T.S. DRAWN BY: TLL
 DATE: 12/8/06 CHECKED BY: MGZ

PLOT DATE = #DATE#
 FILE NAME = #FILE#
 PLOT SCALE = #SCALE#
 USER NAME = #USER#

F.A.P. RTE.	SECTION	COUNTY	TOTAL SHEETS	SHEET NO.
308	118B-1, 18B-2R	ROCK ISLAND	210	10
STA.	TO STA.			
FED. ROAD DIST. NO. 2	ILLINOIS	FED. AID PROJECT		

TYPICAL SECTIONS

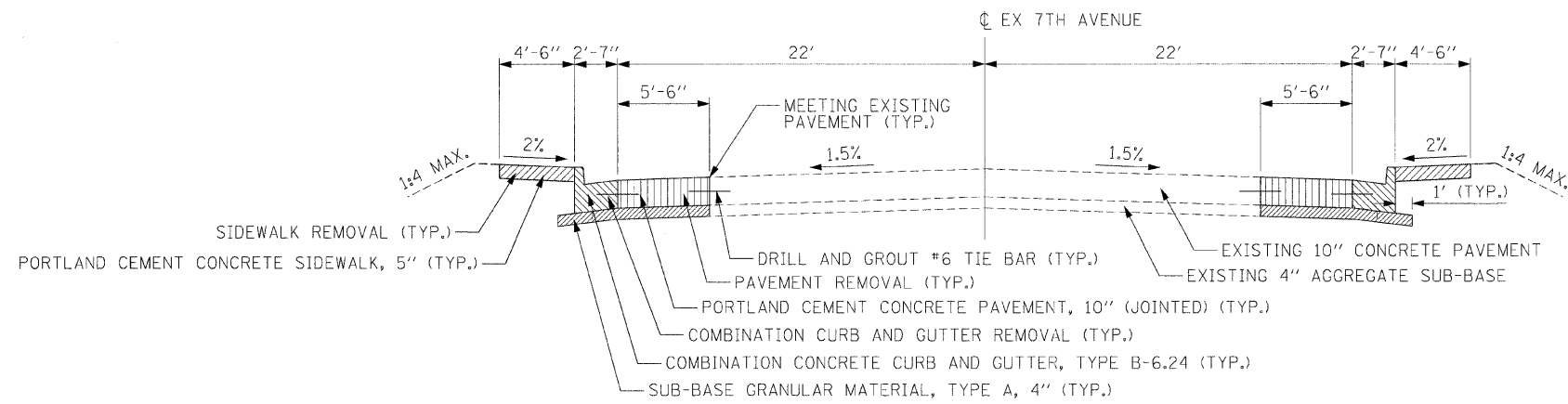

TYPICAL SECTION 7TH AVENUE
 STA 14+06.88 TO STA 15+93.74
 (UNDER IL 92)

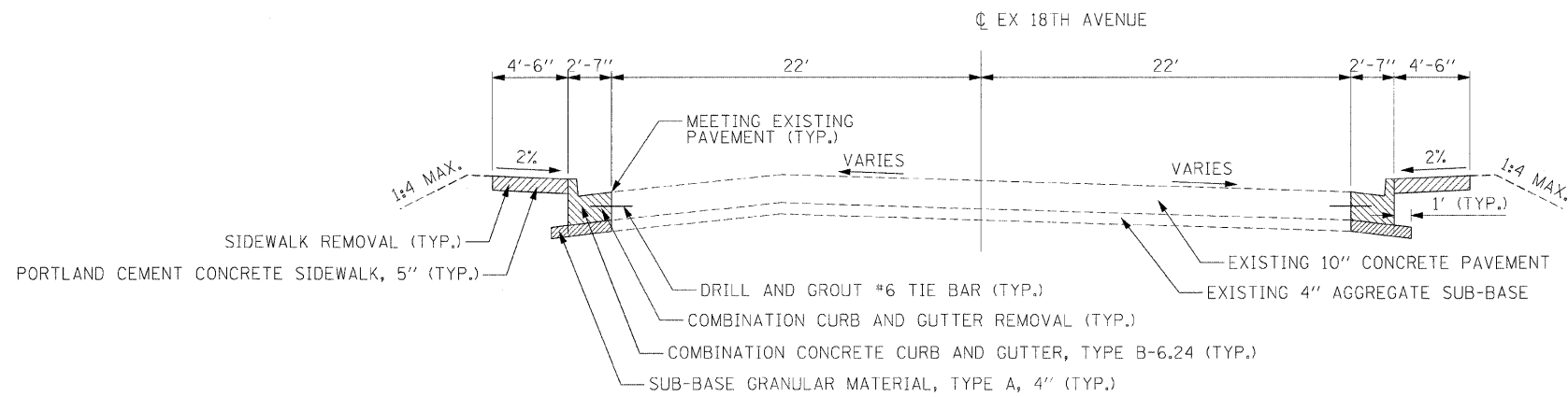

TYPICAL SECTION 18TH AVENUE
 STA 25+60.29 TO STA 27+30.88
 (UNDER IL 92)

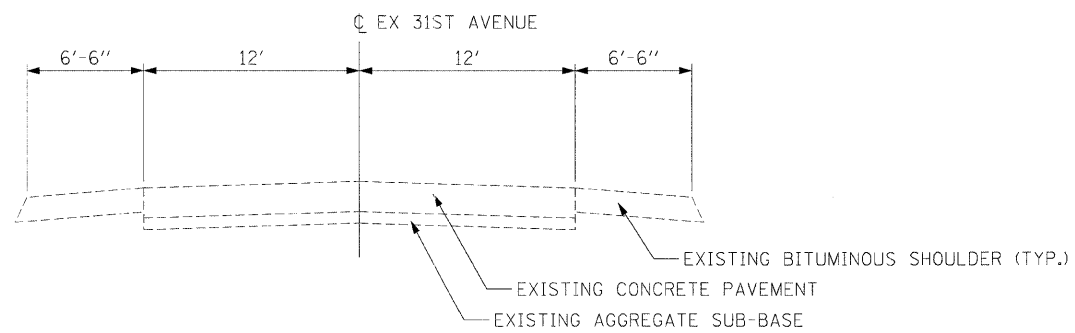

TYPICAL SECTION 31ST AVENUE
 STA 13+77.63 TO STA 16+15.38
 (UNDER IL 92)

REVISIONS		ILLINOIS DEPARTMENT OF TRANSPORTATION
NAME	DATE	
		TYPICAL SECTION 7TH AVENUE 18TH AVENUE 31ST AVENUE SCALE: N.T.S. DATE: 12/8/06

DRAWN BY: TLL
 CHECKED BY: MGZ

7TH AVENUE, 18TH AVENUE, & 31ST AVENUE TYPICAL SECTIONS

SCHEDULE OF QUANTITIES

F.A.P. RTE.	SECTION	COUNTY	TOTAL SHEETS	SHEET NO.
308	108JHB-1,VB,HB-2R	ROCK ISLAND	210	11
STA. TO STA.				
FED. ROAD DIST. NO. 2 ILLINOIS FED. AID PROJECT				

20101400 NITROGEN FERTILIZER NUTRIENT

POUND	LOCATION	OFFSET	REMARKS
36.7	1471+13.26	TO 1477+32.91	LT
121.7	1476+89.60	TO 1506+77.51	LT
9.1	1547+70.90	TO 1549+22.94	RT
5.8	1545+27.34	TO 1546+67.74	LT
16.7	1543+01.20	TO 1546+64.61	RT
12.7	1518+45.47	TO 1521+66.53	RT
17.5	1518+28.28	TO 1521+99.29	LT
9.8	1515+56.98	TO 1517+22.18	LT
28.4	1508+55.50	TO 1515+04.07	LT
13.6	1513+61.46	TO 1517+29.16	RT
21.9	1507+70.91	TO 1512+94.31	RT
30.0	1498+12.54	TO 1505+58.82	RT
25.8	1470+53.96	TO 1474+24.68	RT
34.6	1464+06.63	TO 1470+23.61	RT
29.9	1466+41.08	TO 1470+83.87	LT
3.5	1467+00.00	TO 1467+50.00	MEDIAN
3.5	1467+50.00	TO 1468+00.00	MEDIAN
3.4	1468+00.00	TO 1468+50.00	MEDIAN
3.4	1468+50.00	TO 1469+00.00	MEDIAN
3.4	1469+00.00	TO 1469+50.00	MEDIAN
3.5	1472+00.00	TO 1472+50.00	MEDIAN
3.5	1472+50.00	TO 1473+00.00	MEDIAN
3.5	1473+00.00	TO 1473+50.00	MEDIAN
3.5	1473+50.00	TO 1474+00.00	MEDIAN
3.5	1474+00.00	TO 1474+50.00	MEDIAN
3.4	1479+00.00	TO 1479+50.00	MEDIAN
3.3	1479+50.00	TO 1480+00.00	MEDIAN
3.1	1480+00.00	TO 1480+50.00	MEDIAN
2.9	1480+50.00	TO 1481+00.00	MEDIAN
2.7	1481+00.00	TO 1481+50.00	MEDIAN
2.5	1481+50.00	TO 1482+00.00	MEDIAN
2.3	1482+00.00	TO 1482+50.00	MEDIAN
2.1	1482+50.00	TO 1483+00.00	MEDIAN
1.9	1483+00.00	TO 1483+50.00	MEDIAN
1.7	1483+50.00	TO 1484+00.00	MEDIAN
475 TOTAL			

20101600 POTASSIUM FERTILIZER NUTRIENT

POUND	LOCATION	OFFSET	REMARKS
36.7	1471+13.26	TO 1477+32.91	LT
121.7	1476+89.60	TO 1506+77.51	LT
9.1	1547+70.90	TO 1549+22.94	RT
5.8	1545+27.34	TO 1546+67.74	LT
16.7	1543+01.20	TO 1546+64.61	RT
12.7	1518+45.47	TO 1521+66.53	RT
17.5	1518+28.28	TO 1521+99.29	LT
9.8	1515+56.98	TO 1517+22.18	LT
28.4	1508+55.50	TO 1515+04.07	LT
13.6	1513+61.46	TO 1517+29.16	RT
21.9	1507+70.91	TO 1512+94.31	RT
30.0	1498+12.54	TO 1505+58.82	RT
25.8	1470+53.96	TO 1474+24.68	RT
34.6	1464+06.63	TO 1470+23.61	RT
29.9	1466+41.08	TO 1470+83.87	LT
3.5	1467+00.00	TO 1467+50.00	MEDIAN
3.5	1467+50.00	TO 1468+00.00	MEDIAN
3.4	1468+00.00	TO 1468+50.00	MEDIAN
3.4	1468+50.00	TO 1469+00.00	MEDIAN
3.4	1469+00.00	TO 1469+50.00	MEDIAN
3.5	1472+00.00	TO 1472+50.00	MEDIAN
3.5	1472+50.00	TO 1473+00.00	MEDIAN
3.5	1473+00.00	TO 1473+50.00	MEDIAN
3.5	1473+50.00	TO 1474+00.00	MEDIAN
3.5	1474+00.00	TO 1474+50.00	MEDIAN
3.4	1479+00.00	TO 1479+50.00	MEDIAN
3.3	1479+50.00	TO 1480+00.00	MEDIAN
3.1	1480+00.00	TO 1480+50.00	MEDIAN
2.9	1480+50.00	TO 1481+00.00	MEDIAN
2.7	1481+00.00	TO 1481+50.00	MEDIAN
2.5	1481+50.00	TO 1482+00.00	MEDIAN
2.3	1482+00.00	TO 1482+50.00	MEDIAN
2.1	1482+50.00	TO 1483+00.00	MEDIAN
1.9	1483+00.00	TO 1483+50.00	MEDIAN
1.7	1483+50.00	TO 1484+00.00	MEDIAN
475 TOTAL			

20101500 PHOSPHORUS FERTILIZER NUTRIENT

POUND	LOCATION	OFFSET	REMARKS
36.7	1471+13.26	TO 1477+32.91	LT
121.7	1476+89.60	TO 1506+77.51	LT
9.1	1547+70.90	TO 1549+22.94	RT
5.8	1545+27.34	TO 1546+67.74	LT
16.7	1543+01.20	TO 1546+64.61	RT
12.7	1518+45.47	TO 1521+66.53	RT
17.5	1518+28.28	TO 1521+99.29	LT
9.8	1515+56.98	TO 1517+22.18	LT
28.4	1508+55.50	TO 1515+04.07	LT
13.6	1513+61.46	TO 1517+29.16	RT
21.9	1507+70.91	TO 1512+94.31	RT
30.0	1498+12.54	TO 1505+58.82	RT
25.8	1470+53.96	TO 1474+24.68	RT
34.6	1464+06.63	TO 1470+23.61	RT
29.9	1466+41.08	TO 1470+83.87	LT
3.5	1467+00.00	TO 1467+50.00	MEDIAN
3.5	1467+50.00	TO 1468+00.00	MEDIAN
3.4	1468+00.00	TO 1468+50.00	MEDIAN
3.4	1468+50.00	TO 1469+00.00	MEDIAN
3.4	1469+00.00	TO 1469+50.00	MEDIAN
3.5	1472+00.00	TO 1472+50.00	MEDIAN
3.5	1472+50.00	TO 1473+00.00	MEDIAN
3.5	1473+00.00	TO 1473+50.00	MEDIAN
3.5	1473+50.00	TO 1474+00.00	MEDIAN
3.5	1474+00.00	TO 1474+50.00	MEDIAN
3.4	1479+00.00	TO 1479+50.00	MEDIAN
3.3	1479+50.00	TO 1480+00.00	MEDIAN
3.1	1480+00.00	TO 1480+50.00	MEDIAN
2.9	1480+50.00	TO 1481+00.00	MEDIAN
2.7	1481+00.00	TO 1481+50.00	MEDIAN
2.5	1481+50.00	TO 1482+00.00	MEDIAN
2.3	1482+00.00	TO 1482+50.00	MEDIAN
2.1	1482+50.00	TO 1483+00.00	MEDIAN
1.9	1483+00.00	TO 1483+50.00	MEDIAN
1.7	1483+50.00	TO 1484+00.00	MEDIAN
475 TOTAL			

20200100 EARTH EXCAVATION

CU YD	LOCATION	OFFSET	REMARKS
3.1	1468+50.00	TO 1469+50.00	NB
3.9	1468+50.00	TO 1469+50.00	SB
5	1472+00.00	TO 1473+00.00	NB
4.2	1472+00.00	TO 1473+00.00	SB
6.7	1503+00.00	TO 1505+00.00	NB
4.1	1504+00.00	TO 1505+00.00	SB
25.5	1509+00.00	TO 1511+00.00	NB
6	1509+00.00	TO 1510+00.00	SB
2.9	1514+50.00	TO 1516+50.00	NB
0	1516+00.00	TO 1516+50.00	SB
0	1519+00.00	TO 1520+50.00	NB
4.4	1519+00.00	TO 1520+00.00	SB
7.5	1545+00.00	TO 1546+00.00	NB
0.2	1544+00.00	TO 1545+50.00	SB
1	1548+00.00	TO 1548+50.00	NB
8.8	1548+00.00	TO 1550+00.00	SB
83 TOTAL			

PLOT DATE * * * * *
 FILE NAME * * * * *
 USER * * * * *

REVISIONS		ILLINOIS DEPARTMENT OF TRANSPORTATION
NAME	DATE	
		SCALE: NONE DATE
		DRAWN BY JW
		CHECKED BY MGZ

SCHEDULE OF QUANTITIES

F.A.P. RTE.	SECTION	COUNTY	TOTAL SHEETS	SHEET NO.
308	118A/1B-1, 18A/1B-2R	ROCK ISLAND	210	11A
STA. TO STA.		FED. ROAD DIST. NO. 2 ILLINOIS FED. AID PROJECT		

20400800 FURNISHED EXCAVATION

CU_YD	LOCATION	OFFSET	REMARKS
34.4	1468+50.00 TO 1469+50.00	NB	
45.6	1468+50.00 TO 1469+50.00	SB	
5.7	1472+00.00 TO 1473+00.00	NB	
35.4	1472+00.00 TO 1473+00.00	SB	
12.5	1503+00.00 TO 1505+00.00	NB	
4.0	1504+00.00 TO 1505+00.00	SB	
0.0	1509+00.00 TO 1511+00.00	NB	
21.0	1509+00.00 TO 1510+00.00	SB	
148.8	1514+50.00 TO 1516+50.00	NB	
0.5	1516+00.00 TO 1516+50.00	SB	
5.0	1519+00.00 TO 1520+50.00	NB	
12.2	1519+00.00 TO 1520+00.00	SB	
8.6	1545+00.00 TO 1546+00.00	NB	
15.0	1544+00.00 TO 1545+50.00	SB	
13.8	1548+00.00 TO 1548+50.00	NB	
119.3	1548+00.00 TO 1550+00.00	SB	
72.1	1467+00.00 TO 1467+50.00	MEDIAN	
83.8	1467+50.00 TO 1468+00.00	MEDIAN	
69.4	1468+00.00 TO 1468+50.00	MEDIAN	
29.7	1468+50.00 TO 1469+00.00	MEDIAN	
14	1469+00.00 TO 1469+50.00	MEDIAN	
18.2	1472+00.00 TO 1472+50.00	MEDIAN	
40.9	1472+50.00 TO 1473+00.00	MEDIAN	
57.9	1473+00.00 TO 1473+50.00	MEDIAN	
69.5	1473+50.00 TO 1474+00.00	MEDIAN	
74.1	1474+00.00 TO 1474+50.00	MEDIAN	
65.8	1479+00.00 TO 1479+50.00	MEDIAN	
42.7	1479+50.00 TO 1480+00.00	MEDIAN	
31.5	1480+00.00 TO 1480+50.00	MEDIAN	
27.5	1480+50.00 TO 1481+00.00	MEDIAN	
28.8	1481+00.00 TO 1481+50.00	MEDIAN	
24.2	1481+50.00 TO 1482+00.00	MEDIAN	
15.7	1482+00.00 TO 1482+50.00	MEDIAN	
10	1482+50.00 TO 1483+00.00	MEDIAN	
5.1	1483+00.00 TO 1483+50.00	MEDIAN	
1.5	1483+50.00 TO 1484+00.00	MEDIAN	
101.9	31ST BRIDGE	SB	SOUTH OF BRIDGE
62.9	31ST BRIDGE	SB	NORTH OF BRIDGE
60.0	31ST BRIDGE	NB	SOUTH OF BRIDGE
0.6	31ST BRIDGE	NB	NORTH OF BRIDGE
4.9	RR	SB	SOUTH OF BRIDGE
24.3	RR	SB	NORTH OF BRIDGE
7.1	RR	NB	SOUTH OF BRIDGE
0.0	RR	NB	NORTH OF BRIDGE
21.7	18TH BRIDGE	SB	SOUTH OF BRIDGE
18.8	18TH BRIDGE	SB	NORTH OF BRIDGE
44.5	18TH BRIDGE	NB	SOUTH OF BRIDGE
5.1	18TH BRIDGE	NB	NORTH OF BRIDGE
17.2	7TH BRIDGE	SB	SOUTH OF BRIDGE
103.8	7TH BRIDGE	SB	NORTH OF BRIDGE
14.7	7th BRIDGE	NB	SOUTH OF BRIDGE
48.0	7th BRIDGE	NB	NORTH OF BRIDGE

1800.0 TOTAL
2250.0 TOTAL 25% SHRINKAGE

20800150 TRENCH BACKFILL

CU_YD	LOCATION	OFFSET	REMARKS
33.6	1499+05.60 TO 1500+50.00		
27.0	1513+00.00 TO 1514+17.50		
17.8	1519+50.00 TO 1520+10.60		
3.7	1540+75.00 TO 1540+75.00		
5.2	1541+00.00 TO 1541+00.00		
27.3	1542+55.30 TO 1544+00.00		
30.8	1550+75.00 TO 1552+26.00		
7.2	1552+99.00 TO 1553+20.00		
15.0	1553+20.00 TO 1553+72.00		
26.2	1559+56.60 TO 1560+75.00		

193.8 TOTAL

21101505 TOPSOIL EXCAVATION AND PLACEMENT

CU_YD	LOCATION	DIRECTION	REMARKS
58	31ST	SB	SOUTH OF 31ST
29	31ST	NB	SOUTH OF 31ST
40	31ST	SB	NORTH OF 31ST
11	31ST	NB	NORTH OF 31ST
23	IAIS RR	SB	SOUTH OF RR
6	IAIS RR	NB	SOUTH OF RR
24	IAIS RR	SB	NORTH OF RR
22	IAIS RR	NB	NORTH OF RR
7	18TH	SB	SOUTH OF 18TH
23	18TH	NB	SOUTH OF 18TH
13	18TH	SB	NORTH OF 18TH
4	18TH	NB	NORTH OF 18TH
10	7TH	SB	SOUTH OF 7TH
10	7TH	NB	SOUTH OF 7TH
8	7TH	SB	NORTH OF 7TH
21	7TH	NB	NORTH OF 7TH
28	1467+00.00 TO 1467+50.00	MEDIAN	
28	1467+50.00 TO 1468+00.00	MEDIAN	
27	1468+00.00 TO 1468+50.00	MEDIAN	
27	1468+50.00 TO 1469+00.00	MEDIAN	
27	1469+00.00 TO 1469+50.00	MEDIAN	
28	1472+00.00 TO 1472+50.00	MEDIAN	
28	1472+50.00 TO 1473+00.00	MEDIAN	
28	1473+00.00 TO 1473+50.00	MEDIAN	
28	1473+50.00 TO 1474+00.00	MEDIAN	
28	1474+00.00 TO 1474+50.00	MEDIAN	
27	1479+00.00 TO 1479+50.00	MEDIAN	
26	1479+50.00 TO 1480+00.00	MEDIAN	
25	1480+00.00 TO 1480+50.00	MEDIAN	
23	1480+50.00 TO 1481+00.00	MEDIAN	
22	1481+00.00 TO 1481+50.00	MEDIAN	
20	1481+50.00 TO 1482+00.00	MEDIAN	
18	1482+00.00 TO 1482+50.00	MEDIAN	
17	1482+50.00 TO 1483+00.00	MEDIAN	
15	1483+00.00 TO 1483+50.00	MEDIAN	
13	1483+50.00 TO 1484+00.00	MEDIAN	

792 TOTAL
991 TOTAL 25% SHRINKAGE

21400100 GRADING AND SHAPING DITCHES

FOOT	LOCATION	OFFSET	DIRECTION	REMARKS
10	1486+60.02	-73.68	SB	
10	1499+05.55	-92.38	SB	
10	1501+83.19	-102.22	SB	
10	1511+46.85	-102.38	SB	
10	1515+91.99	-87.23	SB	
10	1516+57.14	-93.38	SB	
10	1516+57.20	83.38	NB	
10	1519+83.64	-99.30	SB	
10	1523+84.42	90.66	NB	
10	1525+77.65	-78.19	SB	

100 TOTAL

REVISIONS		ILLINOIS DEPARTMENT OF TRANSPORTATION
NAME	DATE	

SCALE: NONE DRAWN BY: JW
DATE CHECKED BY: MGZ

PLOT DATE * * * DATE * * *
FILE NAME * * * FILE * * *
USER * * * USER * * *

SCHEDULE OF QUANTITIES

F.A.P. RTE.	SECTION	COUNTY	TOTAL SHEETS	SHEET NO.
308	11B,B-1A,B-2R	ROCK ISLAND	210	118
STA. TO STA.				
FED. ROAD DIST. NO. 2		ILLINOIS		FED. AID PROJECT

25000210 SEEDING, CLASS 2A

28000700 MULCH, METHOD 1

ACRE	LOCATION			OFFSET	REMARKS
0.384	1464+06.63	TO	1470+23.61	RT	
0.332	1466+41.08	TO	1470+83.87	LT	
0.286	1470+53.96	TO	1474+24.68	RT	
0.407	1471+13.26	TO	1477+32.91	LT	
0.333	1498+12.54	TO	1505+58.82	RT	
1.352	1476+89.60	TO	1506+77.51	LT	
0.243	1507+70.91	TO	1512+94.31	RT	
0.316	1508+55.50	TO	1515+04.07	LT	
0.108	1515+56.98	TO	1517+22.18	LT	
0.151	1513+61.46	TO	1517+29.16	RT	
0.141	1518+45.47	TO	1521+66.53	RT	
0.194	1518+28.28	TO	1521+99.29	LT	
0.185	1543+01.20	TO	1546+64.61	RT	
0.065	1545+27.34	TO	1546+67.74	LT	
0.101	1547+70.90	TO	1549+22.94	RT	
0.039	1467+00.00	TO	1467+50.00	MEDIAN	
0.038	1467+50.00	TO	1468+00.00	MEDIAN	
0.038	1468+00.00	TO	1468+50.00	MEDIAN	
0.038	1468+50.00	TO	1469+00.00	MEDIAN	
0.038	1469+00.00	TO	1469+50.00	MEDIAN	
0.038	1472+00.00	TO	1472+50.00	MEDIAN	
0.039	1472+50.00	TO	1473+00.00	MEDIAN	
0.039	1473+00.00	TO	1473+50.00	MEDIAN	
0.039	1473+50.00	TO	1474+00.00	MEDIAN	
0.039	1474+00.00	TO	1474+50.00	MEDIAN	
0.038	1479+00.00	TO	1479+50.00	MEDIAN	
0.037	1479+50.00	TO	1480+00.00	MEDIAN	
0.035	1480+00.00	TO	1480+50.00	MEDIAN	
0.032	1480+50.00	TO	1481+00.00	MEDIAN	
0.030	1481+00.00	TO	1481+50.00	MEDIAN	
0.028	1481+50.00	TO	1482+00.00	MEDIAN	
0.026	1482+00.00	TO	1482+50.00	MEDIAN	
0.023	1482+50.00	TO	1483+00.00	MEDIAN	
0.021	1483+00.00	TO	1483+50.00	MEDIAN	
0.019	1483+50.00	TO	1484+00.00	MEDIAN	
5.3 TOTAL					

ACRE	LOCATION			OFFSET	REMARKS
1.536	1464+06.63	TO	1470+23.61	RT	
1.328	1466+41.08	TO	1470+83.87	LT	
1.144	1470+53.96	TO	1474+24.68	RT	
1.628	1471+13.26	TO	1477+32.91	LT	
1.332	1498+12.54	TO	1505+58.82	RT	
5.408	1476+89.60	TO	1506+77.51	LT	
0.972	1507+70.91	TO	1512+94.31	RT	
1.264	1508+55.50	TO	1515+04.07	LT	
0.432	1515+56.98	TO	1517+22.18	LT	
0.604	1513+61.46	TO	1517+29.16	RT	
0.564	1518+45.47	TO	1521+66.53	RT	
0.776	1518+28.28	TO	1521+99.29	LT	
0.74	1543+01.20	TO	1546+64.61	RT	
0.26	1545+27.34	TO	1546+67.74	LT	
0.404	1547+70.90	TO	1549+22.94	RT	
0.156	1467+00.00	TO	1467+50.00	MEDIAN	
0.152	1467+50.00	TO	1468+00.00	MEDIAN	
0.152	1468+00.00	TO	1468+50.00	MEDIAN	
0.152	1468+50.00	TO	1469+00.00	MEDIAN	
0.152	1469+00.00	TO	1469+50.00	MEDIAN	
0.152	1472+00.00	TO	1472+50.00	MEDIAN	
0.156	1472+50.00	TO	1473+00.00	MEDIAN	
0.156	1473+00.00	TO	1473+50.00	MEDIAN	
0.156	1473+50.00	TO	1474+00.00	MEDIAN	
0.156	1474+00.00	TO	1474+50.00	MEDIAN	
0.152	1479+00.00	TO	1479+50.00	MEDIAN	
0.148	1479+50.00	TO	1480+00.00	MEDIAN	
0.14	1480+00.00	TO	1480+50.00	MEDIAN	
0.128	1480+50.00	TO	1481+00.00	MEDIAN	
0.12	1481+00.00	TO	1481+50.00	MEDIAN	
0.112	1481+50.00	TO	1482+00.00	MEDIAN	
0.104	1482+00.00	TO	1482+50.00	MEDIAN	
0.092	1482+50.00	TO	1483+00.00	MEDIAN	
0.084	1483+00.00	TO	1483+50.00	MEDIAN	
0.076	1483+50.00	TO	1484+00.00	MEDIAN	
21.2 TOTAL					

ASSUME 4 APPLICATIONS PRIOR TO FINAL SEEDING

25000750 MOWING

ACRE	LOCATION			OFFSET	REMARKS
0.384	1464+06.63	TO	1470+23.61	RT	
0.332	1466+41.08	TO	1470+83.87	LT	
0.286	1470+53.96	TO	1474+24.68	RT	
0.407	1471+13.26	TO	1477+32.91	LT	
0.333	1498+12.54	TO	1505+58.82	RT	
1.352	1476+89.60	TO	1506+77.51	LT	
0.243	1507+70.91	TO	1512+94.31	RT	
0.316	1508+55.50	TO	1515+04.07	LT	
0.108	1515+56.98	TO	1517+22.18	LT	
0.151	1513+61.46	TO	1517+29.16	RT	
0.141	1518+45.47	TO	1521+66.53	RT	
0.194	1518+28.28	TO	1521+99.29	LT	
0.185	1543+01.20	TO	1546+64.61	RT	
0.065	1545+27.34	TO	1546+67.74	LT	
0.101	1547+70.90	TO	1549+22.94	RT	
0.039	1467+00.00	TO	1467+50.00	MEDIAN	
0.038	1467+50.00	TO	1468+00.00	MEDIAN	
0.038	1468+00.00	TO	1468+50.00	MEDIAN	
0.038	1468+50.00	TO	1469+00.00	MEDIAN	
0.038	1469+00.00	TO	1469+50.00	MEDIAN	
0.038	1472+00.00	TO	1472+50.00	MEDIAN	
0.039	1472+50.00	TO	1473+00.00	MEDIAN	
0.039	1473+00.00	TO	1473+50.00	MEDIAN	
0.039	1473+50.00	TO	1474+00.00	MEDIAN	
0.039	1474+00.00	TO	1474+50.00	MEDIAN	
0.038	1479+00.00	TO	1479+50.00	MEDIAN	
0.037	1479+50.00	TO	1480+00.00	MEDIAN	
0.035	1480+00.00	TO	1480+50.00	MEDIAN	
0.032	1480+50.00	TO	1481+00.00	MEDIAN	
0.030	1481+00.00	TO	1481+50.00	MEDIAN	
0.028	1481+50.00	TO	1482+00.00	MEDIAN	
0.026	1482+00.00	TO	1482+50.00	MEDIAN	
0.023	1482+50.00	TO	1483+00.00	MEDIAN	
0.021	1483+00.00	TO	1483+50.00	MEDIAN	
0.019	1483+50.00	TO	1484+00.00	MEDIAN	
5.3 TOTAL					

REVISIONS		ILLINOIS DEPARTMENT OF TRANSPORTATION
NAME	DATE	
SCALE: NONE		DRAWN BY JW
DATE		CHECKED BY MGZ

PLOT DATE - #DAYS
FILE NAME - #FILES
PLOT SCALE - #SCALES
USER NAME - #USERS

SCHEDULE OF QUANTITIES

SCHEDULE OF QUANTITIES

F.A.P. RTE.	SECTION	COUNTY	TOTAL SHEETS	SHEET NO.
308	10R,10B-1,10B,10B-2R	ROCK ISLAND	210	12
STA.		TO STA.		
FED. ROAD DIST. NO. 2		ILLINOIS	FED. AID PROJECT	

28000500 INLET AND PIPE PROTECTION

EACH	LOCATION	OFFSET	REMARKS
1	1469+65.39	RT	
1	1470+07.28	LT	
1	1471+32.87	RT	
1	1471+75.68	LT	
1	1486+58.45	LT	
1	1487+58.78	LT	
1	1499+05.46	RT	
1	1500+50.06	RT	
1	1501+83.33	RT	
1	1504+32.78	LT	
1	1506+37.28	LT	
1	1508+97.87	LT	
1	1511+38.69	LT	
1	1511+46.86	RT	
1	1513+00.00	RT	
1	1514+17.34	RT	
1	1514+94.42	RT	
1	1515+09.69	RT	
1	1515+71.29	RT	
1	1516+93.92	LT	
1	1518+53.90	LT	
1	1519+50.04	RT	
1	1519+95.19	LT	
1	1520+10.67	RT	
1	1540+57.49	LT	
1	1540+74.96	LT	
1	1541+00.00	LT	
1	1542+55.39	LT	
1	1543+56.67	RT	
1	1544+00.04	LT	
1	1546+41.38	RT	
1	1548+02.77	RT	
1	1552+26.05	LT	
1	1552+98.77	LT	
1	1553+20.08	LT	
1	1553+72.10	LT	
1	1556+53.59	LT	
1	1559+55.70	LT	
1	1560+75.08	LT	
<hr/>			
39	TOTAL		

31100300 SUB-BASE GRANULAR MATERIAL, TYPE A 4"

SQ YD	LOCATION	SHEET	REMARKS
0	1451+00.00 TO 1457+00.00	SHEET 1	
0	1457+00.00 TO 1463+00.00	SHEET 2	
0	1463+00.00 TO 1469+00.00	SHEET 3	
0	1469+00.00 TO 1475+00.00	SHEET 4	
0	1475+00.00 TO 1481+00.00	SHEET 5	
215	1481+00.00 TO 1487+00.00	SHEET 6	
474	1487+00.00 TO 1493+00.00	SHEET 7	
439	1493+00.00 TO 1499+00.00	SHEET 8	
355	1499+00.00 TO 1504+00.00	SHEET 9	
363	1504+00.00 TO 1510+00.00	SHEET 10	
357	1510+00.00 TO 1515+00.00	SHEET 11	
455	1515+00.00 TO 1521+00.00	SHEET 12	
474	1521+00.00 TO 1527+00.00	SHEET 13	
508	1527+00.00 TO 1533+00.00	SHEET 14	
485	1533+00.00 TO 1539+00.00	SHEET 15	
469	1539+00.00 TO 1545+00.00	SHEET 16	
570	1545+00.00 TO 1551+00.00	SHEET 17	
455	1551+00.00 TO 1557+00.00	SHEET 18	
341	1557+00.00 TO 1561+63.55	SHEET 19	
<hr/>			
5,960	TOTAL		

40600635 LEVELING BINDER (MACHINE METHOD), N70

TON	LOCATION	OFFSET	DIRECTION	REMARKS
16.0	IAIS RR		SB	SOUTH OF IAIS RR
11.6	IAIS RR		NB	SOUTH OF IAIS RR
1.6	IAIS RR		NB	NORTH OF IAIS RR
6.6	18TH AVE BRIDGE		SB	SOUTH OF 18TH
7.2	18TH AVE BRIDGE		NB	SOUTH OF 18TH
20.8	18TH AVE BRIDGE		SB	NORTH OF 18TH
22.8	18TH AVE BRIDGE		NB	NORTH OF 18TH
2.0	7TH AVE BRIDGE		SB	NORTH OF 7TH
1.9	7TH AVE BRIDGE		NB	NORTH OF 7TH
<hr/>				
91	TOTAL			

28100125 STONE RIPRAP, CLASS B3

SQ YD	LOCATION	OFFSET	REMARKS
13.33	1547+98.12	82' RT	(10'X12')
13.33	1546+36.39	82' RT	(10'X12')
13.33	1469+58.74	99' RT	(10'X12')
13.33	1470+02.58	122' LT	(10'X12')
13.33	1471+28.33	106' RT	(10'X12')
13.33	1471+72.61	112' LT	(10'X12')
13.33	1506+30.48	107' LT	(10'X12')
13.33	1508+94.96	108' LT	(10'X12')
13.33	1516+87.71	99' LT	(10'X12')
13.33	1518+48.53	99' LT	(10'X12')
<hr/>			
134	TOTAL		

40603310 HOT-MIX ASPHALT SURFACE COURSE, MIX "C", N50

TON	LOCATION	SHEET	REMARKS
0	1451+00.00 TO 1457+00.00	SHEET 1	
0	1457+00.00 TO 1463+00.00	SHEET 2	
95	1463+00.00 TO 1469+00.00	SHEET 3	
99	1469+00.00 TO 1475+00.00	SHEET 4	
78	1475+00.00 TO 1481+00.00	SHEET 5	
77	1481+00.00 TO 1487+00.00	SHEET 6	
74	1487+00.00 TO 1493+00.00	SHEET 7	
83	1493+00.00 TO 1499+00.00	SHEET 8	
124	1499+00.00 TO 1504+00.00	SHEET 9	
63	1504+00.00 TO 1510+00.00	SHEET 10	
112	1510+00.00 TO 1515+00.00	SHEET 11	
82	1515+00.00 TO 1521+00.00	SHEET 12	
31	1521+00.00 TO 1527+00.00	SHEET 13	
0	1527+00.00 TO 1533+00.00	SHEET 14	
0	1533+00.00 TO 1539+00.00	SHEET 15	
23	1539+00.00 TO 1545+00.00	SHEET 16	
69	1545+00.00 TO 1551+00.00	SHEET 17	
5	1551+00.00 TO 1557+00.00	SHEET 18	
0	1557+00.00 TO 1561+63.55	SHEET 19	
<hr/>			
1,015	TOTAL		

PLOT DATE * * * * *
 FILE NAME * * * * *
 USER NAME * * * * *

REVISIONS		ILLINOIS DEPARTMENT OF TRANSPORTATION
NAME	DATE	
		SCALE: NONE DRAWN BY JW CHECKED BY MGZ

SCHEDULE OF QUANTITIES

F.A.P. RTE.	SECTION	COUNTY	TOTAL SHEETS	SHEET NO.
308	106/107-1/0/108-2/10	ROCK ISLAND	210	13
STA.		TO STA.		
FED. ROAD DIST. NO. 2		ILLINOIS	FED. AID PROJECT	

40603340 HOT-MIX ASPHALT SURFACE COURSE, MIX "D", N70

TON	LOCATION	SHEET	REMARKS
0	1451+00.00 TO 1457+00.00	SHEET 1	
0	1457+00.00 TO 1463+00.00	SHEET 2	
13	1463+00.00 TO 1469+00.00	SHEET 3	
63	1469+00.00 TO 1475+00.00	SHEET 4	
0	1475+00.00 TO 1481+00.00	SHEET 5	
0	1481+00.00 TO 1487+00.00	SHEET 6	
0	1487+00.00 TO 1493+00.00	SHEET 7	
0	1493+00.00 TO 1499+00.00	SHEET 8	
0	1499+00.00 TO 1504+00.00	SHEET 9	
134	1504+00.00 TO 1510+00.00	SHEET 10	
0	1510+00.00 TO 1515+00.00	SHEET 11	
146	1515+00.00 TO 1521+00.00	SHEET 12	
25	1521+00.00 TO 1527+00.00	SHEET 13	
0	1527+00.00 TO 1533+00.00	SHEET 14	
0	1533+00.00 TO 1539+00.00	SHEET 15	
0	1539+00.00 TO 1545+00.00	SHEET 16	
80	1545+00.00 TO 1551+00.00	SHEET 17	
0	1551+00.00 TO 1557+00.00	SHEET 18	
0	1557+00.00 TO 1561+63.55	SHEET 19	
39	1469+00.00 TO 1475+00.00	SHEET 4	STAGE 1
33	1515+00.00 TO 1521+00.00	SHEET 12	STAGE 1
34	1545+00.00 TO 1551+00.00	SHEET 17	STAGE 1
<hr/>			
567	TOTAL		

42000501 PORTLAND CEMENT CONCRETE PAVEMENT 10" (JOINTED)

SQ_YD	LOCATION	OFFSET	DIRECTION	REMARKS
54	7TH AVE BRIDGE			NORTH OF 7TH
54	7TH AVE BRIDGE			SOUTH OF 7TH
<hr/>				
108	TOTAL			

42000520 PORTLAND CEMENT CONCRETE PAVEMENT 11"

SQ_YD	LOCATION	SHEET	REMARKS
0	1451+00.00 TO 1457+00.00	SHEET 1	
0	1457+00.00 TO 1463+00.00	SHEET 2	
0	1463+00.00 TO 1469+00.00	SHEET 3	
0	1469+00.00 TO 1475+00.00	SHEET 4	
0	1475+00.00 TO 1481+00.00	SHEET 5	
215	1481+00.00 TO 1487+00.00	SHEET 6	
474	1487+00.00 TO 1493+00.00	SHEET 7	
439	1493+00.00 TO 1499+00.00	SHEET 8	
355	1499+00.00 TO 1504+00.00	SHEET 9	
363	1504+00.00 TO 1510+00.00	SHEET 10	
357	1510+00.00 TO 1515+00.00	SHEET 11	
385	1515+00.00 TO 1521+00.00	SHEET 12	
474	1521+00.00 TO 1527+00.00	SHEET 13	
508	1527+00.00 TO 1533+00.00	SHEET 14	
485	1533+00.00 TO 1539+00.00	SHEET 15	
469	1539+00.00 TO 1545+00.00	SHEET 16	
394	1545+00.00 TO 1551+00.00	SHEET 17	
455	1551+00.00 TO 1557+00.00	SHEET 18	
341	1557+00.00 TO 1561+63.55	SHEET 19	
<hr/>			
5,714	TOTAL		

42001165 BRIDGE APPROACH PAVEMENT

SQ_YD	LOCATION	OFFSET	DIRECTION	REMARKS
139	31ST AVE BRIDGE		NB	SOUTH OF 31ST
139	31ST AVE BRIDGE		SB	SOUTH OF 31ST
139	31ST AVE BRIDGE		NB	NORTH OF 31ST
139	31ST AVE BRIDGE		SB	NORTH OF 31ST
281	RR BRIDGE			SOUTH OF RR
283	RR BRIDGE			NORTH OF RR
252	18TH AVE BRIDGE			SOUTH OF 18TH
253	18TH AVE BRIDGE			NORTH OF 18TH
252	7TH AVE BRIDGE			SOUTH OF 7TH
253	7TH AVE BRIDGE			NORTH OF 7TH
<hr/>				
2,129	TOTAL			

42001420 BRIDGE APPROACH PAVEMENT CONNECTOR (PCC)

SQ_YD	LOCATION	OFFSET	DIRECTION	REMARKS
28	31ST AVE BRIDGE		NB	SOUTH OF 31ST
28	31ST AVE BRIDGE		SB	SOUTH OF 31ST
28	31ST AVE BRIDGE		NB	NORTH OF 31ST
28	31ST AVE BRIDGE		SB	NORTH OF 31ST
72	RR BRIDGE			SOUTH OF RR
56	RR BRIDGE			NORTH OF RR
51	18TH AVE BRIDGE			SOUTH OF 18TH
51	18TH AVE BRIDGE			NORTH OF 18TH
51	7TH AVE BRIDGE			SOUTH OF 7TH
51	7TH AVE BRIDGE			NORTH OF 7TH
<hr/>				
444	TOTAL			

44000100 PAVEMENT REMOVAL

SQ_YD	LOCATION	OFFSET	DIRECTION	REMARKS
54	7TH AVE BRIDGE			NORTH OF 7TH
54	7TH AVE BRIDGE			SOUTH OF 7TH
<hr/>				
108	TOTAL			

44000155 HOT-MIX ASPHALT SURFACE COURSE REMOVAL, 1 1/2"

SQ_YD	LOCATION	OFFSET	DIRECTION	REMARKS
463	31ST AVE BRIDGE		NB	
392	18TH AVE BRIDGE		NB	
400	7TH AVE BRIDGE		NB	
<hr/>				
1,255	TOTAL			

PLOT DATE * DATE *
FILE NAME * FILE *
USER NAME * USER *

REVISIONS		ILLINOIS DEPARTMENT OF TRANSPORTATION
NAME	DATE	
		SCALE: NONE DATE
DRAWN BY JW		CHECKED BY MGZ
DATE		

SCHEDULE OF QUANTITIES

F.A.P. RTE.	SECTION	COUNTY	TOTAL SHEETS	SHEET NO.
308	118B,118-1,118B,118-2R	ROCK ISLAND	210	14
STA. TO STA.				
FED. ROAD DIST. NO. 2 ILLINOIS FED. AID PROJECT				

44000198 HOT-MIX ASPHALT SURFACE REMOVAL, VARIABLE DEPTH

SQ YD	LOCATION	SHEET	REMARKS
0	1451+00.00 TO 1457+00.00	SHEET 1	
0	1457+00.00 TO 1463+00.00	SHEET 2	
156	1463+00.00 TO 1469+00.00	SHEET 3	
745	1469+00.00 TO 1475+00.00	SHEET 4	
0	1475+00.00 TO 1481+00.00	SHEET 5	
0	1481+00.00 TO 1487+00.00	SHEET 6	
0	1487+00.00 TO 1493+00.00	SHEET 7	
0	1493+00.00 TO 1499+00.00	SHEET 8	
0	1499+00.00 TO 1504+00.00	SHEET 9	
1597	1504+00.00 TO 1510+00.00	SHEET 10	
0	1510+00.00 TO 1515+00.00	SHEET 11	
1735	1515+00.00 TO 1521+00.00	SHEET 12	
303	1521+00.00 TO 1527+00.00	SHEET 13	
0	1527+00.00 TO 1533+00.00	SHEET 14	
0	1533+00.00 TO 1539+00.00	SHEET 15	
0	1539+00.00 TO 1545+00.00	SHEET 16	
953	1545+00.00 TO 1551+00.00	SHEET 17	
0	1551+00.00 TO 1557+00.00	SHEET 18	
0	1557+00.00 TO 1561+63.55	SHEET 19	
5,489	TOTAL		

44004250 PAVED SHOULDER REMOVAL

SQ YD	LOCATION	SHEET	REMARKS
0	1451+00.00 TO 1457+00.00	SHEET 1	
0	1457+00.00 TO 1463+00.00	SHEET 2	
1131	1463+00.00 TO 1469+00.00	SHEET 3	
1397	1469+00.00 TO 1475+00.00	SHEET 4	
930	1475+00.00 TO 1481+00.00	SHEET 5	
915	1481+00.00 TO 1487+00.00	SHEET 6	
877	1487+00.00 TO 1493+00.00	SHEET 7	
980	1493+00.00 TO 1499+00.00	SHEET 8	
1481	1499+00.00 TO 1504+00.00	SHEET 9	
859	1504+00.00 TO 1510+00.00	SHEET 10	
1337	1510+00.00 TO 1515+00.00	SHEET 11	
1086	1515+00.00 TO 1521+00.00	SHEET 12	
371	1521+00.00 TO 1527+00.00	SHEET 13	
0	1527+00.00 TO 1533+00.00	SHEET 14	
0	1533+00.00 TO 1539+00.00	SHEET 15	
267	1539+00.00 TO 1545+00.00	SHEET 16	
925	1545+00.00 TO 1551+00.00	SHEET 17	
49	1551+00.00 TO 1557+00.00	SHEET 18	
0	1557+00.00 TO 1561+63.55	SHEET 19	
12,605	TOTAL		

44000500 COMBINATION CURB AND GUTTER REMOVAL

FOOT	LOCATION	OFFSET	DIRECTION	REMARKS
88	18TH AVE BRIDGE			SOUTH OF 18TH
88	18TH AVE BRIDGE			NORTH OF 18TH
87	7TH AVE BRIDGE			SOUTH OF 7TH
87	7TH AVE BRIDGE			NORTH OF 7TH
17	1499+26.77	-37.56		
15	1514+07.69	-82.04		
18	1522+92.92	-38.39		
18	1543+70.43	37.22		
418	TOTAL			

44200571 CLASS A PATCHES, TYPE IV, 11 INCH

SQ YD	LOCATION	OFFSET	DIRECTION	REMARKS
41	1469+41.30		NB	SOUTH OF 31ST
41	1469+68.80		SB	SOUTH OF 31ST
40	1471+71.80		NB	NORTH OF 31ST
40	1471+99.40		SB	NORTH OF 31ST
54	1505+19.30		NB	SOUTH OF RR
77	1505+58.00		SB	SOUTH OF RR
66	1508+59.00		NB	NORTH OF RR
104	1509+17.50		SB	NORTH OF RR
27	1516+70.00		SB	SOUTH OF 18TH
29	1516+73.20		NB	SOUTH OF 18TH
27	1519+82.00		SB	NORTH OF 18TH
29	1519+84.30		NB	NORTH OF 18TH
30	1546+15.00		NB	SOUTH OF 7TH
29	1546+16.70		SB	SOUTH OF 7TH
29	1548+28.50		SB	NORTH OF 7TH
28	1548+29.10		NB	NORTH OF 7TH
691	TOTAL			

44000700 APPROACH SLAB REMOVAL

SQ YD	LOCATION	SHEET	REMARKS
0	1451+00.00 TO 1457+00.00	SHEET 1	
0	1457+00.00 TO 1463+00.00	SHEET 2	
0	1463+00.00 TO 1469+00.00	SHEET 3	
481	1469+00.00 TO 1475+00.00	SHEET 4	
0	1475+00.00 TO 1481+00.00	SHEET 5	
0	1481+00.00 TO 1487+00.00	SHEET 6	
0	1487+00.00 TO 1493+00.00	SHEET 7	
0	1493+00.00 TO 1499+00.00	SHEET 8	
0	1499+00.00 TO 1504+00.00	SHEET 9	
785	1504+00.00 TO 1510+00.00	SHEET 10	
0	1510+00.00 TO 1515+00.00	SHEET 11	
428	1515+00.00 TO 1521+00.00	SHEET 12	
0	1521+00.00 TO 1527+00.00	SHEET 13	
0	1527+00.00 TO 1533+00.00	SHEET 14	
0	1533+00.00 TO 1539+00.00	SHEET 15	
0	1539+00.00 TO 1545+00.00	SHEET 16	
422	1545+00.00 TO 1551+00.00	SHEET 17	
0	1551+00.00 TO 1557+00.00	SHEET 18	
0	1557+00.00 TO 1561+63.55	SHEET 19	
2,116	TOTAL		

REVISIONS		ILLINOIS DEPARTMENT OF TRANSPORTATION
NAME	DATE	
SCALE: NONE	DRAWN BY JW	
DATE	CHECKED BY MGZ	

PLOT DATE * * * * *
 FILE NAME * * * * *
 USER NAME * * * * *

SCHEDULE OF QUANTITIES

F.A.P. RTE.	SECTION	COUNTY	TOTAL SHEETS	SHEET NO.
30B	106WB-1WBWB-2R	ROCK ISLAND	210	15
STA. TO STA.				
FED. ROAD DIST. NO. 2 ILLINOIS			FED. AID PROJECT	

48101200 AGGREGATE SHOULDERS, TYPE B

TON	LOCATION	SHEET	REMARKS
0	1451+00.00 TO 1457+00.00	SHEET 1	
0	1457+00.00 TO 1463+00.00	SHEET 2	
16	1463+00.00 TO 1469+00.00	SHEET 3	
24	1469+00.00 TO 1475+00.00	SHEET 4	
12	1475+00.00 TO 1481+00.00	SHEET 5	
12	1481+00.00 TO 1487+00.00	SHEET 6	
11	1487+00.00 TO 1493+00.00	SHEET 7	
13	1493+00.00 TO 1499+00.00	SHEET 8	
19	1499+00.00 TO 1504+00.00	SHEET 9	
14	1504+00.00 TO 1510+00.00	SHEET 10	
18	1510+00.00 TO 1515+00.00	SHEET 11	
17	1515+00.00 TO 1521+00.00	SHEET 12	
3	1521+00.00 TO 1527+00.00	SHEET 13	
0	1527+00.00 TO 1533+00.00	SHEET 14	
0	1533+00.00 TO 1539+00.00	SHEET 15	
4	1539+00.00 TO 1545+00.00	SHEET 16	
14	1545+00.00 TO 1551+00.00	SHEET 17	
1	1551+00.00 TO 1557+00.00	SHEET 18	
0	1557+00.00 TO 1561+63.55	SHEET 19	
178 TOTAL			

48203023 HOT-MIX ASPHALT SHOULDERS, 6 1/2"

SQ YD	LOCATION	SHEET	REMARKS
0	1451+00.00 TO 1457+00.00	SHEET 1	
0	1457+00.00 TO 1463+00.00	SHEET 2	
1131	1463+00.00 TO 1469+00.00	SHEET 3	
1181	1469+00.00 TO 1475+00.00	SHEET 4	
930	1475+00.00 TO 1481+00.00	SHEET 5	
915	1481+00.00 TO 1487+00.00	SHEET 6	
877	1487+00.00 TO 1493+00.00	SHEET 7	
980	1493+00.00 TO 1499+00.00	SHEET 8	
1481	1499+00.00 TO 1504+00.00	SHEET 9	
745	1504+00.00 TO 1510+00.00	SHEET 10	
1337	1510+00.00 TO 1515+00.00	SHEET 11	
977	1515+00.00 TO 1521+00.00	SHEET 12	
371	1521+00.00 TO 1527+00.00	SHEET 13	
0	1527+00.00 TO 1533+00.00	SHEET 14	
0	1533+00.00 TO 1539+00.00	SHEET 15	
267	1539+00.00 TO 1545+00.00	SHEET 16	
822	1545+00.00 TO 1551+00.00	SHEET 17	
53	1551+00.00 TO 1557+00.00	SHEET 18	
0	1557+00.00 TO 1561+63.55	SHEET 19	
12,067 TOTAL			

54215547 METAL END SECTIONS 12"

EACH	LOCATION	OFFSET	DIRECTION	REMARKS
1	31ST AVE BRIDGE	99.30	NB	SOUTH OF 31ST
1	31ST AVE BRIDGE	-109.75	SB	SOUTH OF 31ST
1	31ST AVE BRIDGE	107.44	NB	NORTH OF 31ST
1	31ST AVE BRIDGE	-100.17	SB	NORTH OF 31ST
1	IAIS RR	-95.58	SB	SOUTH OF RR
1	IAIS RR	-95.58	SB	NORTH OF RR
1	18TH AVE BRIDGE	-87.17	SB	SOUTH OF 18TH
1	18TH AVE BRIDGE	-87.34	SB	NORTH OF 18TH
1	7TH AVE BRIDGE	82.15	NB	SOUTH OF 7TH
1	7TH AVE BRIDGE	82.29	NB	NORTH OF 7TH
10 TOTAL				

550A0340 STORM SEWERS, CLASS A, TYPE 2 12"

FOOT	LOCATION	OFFSET	DIRECTION	REMARKS
145	1499+05.60			
118	1513+00.00			
61	1519+50.00			
18	1540+75.00			
25	1541+00.00			
145	1542+55.30			
151	1550+75.00			
120	1559+56.60			
783 TOTAL				

550A0360 STORM SEWERS, CLASS A, TYPE 2 15"

FOOT	LOCATION	OFFSET	DIRECTION	REMARKS
22	1552+99.00			
52	1553+20.00			
74 TOTAL				

60100060 CONCRETE HEADWALL FOR PIPE DRAINS

EACH	LOCATION	OFFSET	DIRECTION	REMARKS
1	1469+73.29	71.88	NB	31ST AVE BRIDGE SOUTH ABUTMENT
1	1470+34.84	-70.77	SB	31ST AVE BRIDGE SOUTH ABUTMENT
1	1471+04.60	73.51	NB	31ST AVE BRIDGE NORTH ABUTMENT
1	1471+67.13	-71.38	SB	31ST AVE BRIDGE NORTH ABUTMENT
1			NB	RR BRIDGE SOUTH ABUTMENT
1			SB	RR BRIDGE SOUTH ABUTMENT
1			NB	RR BRIDGE NORTH ABUTMENT
1			SB	RR BRIDGE NORTH ABUTMENT
1	1517+22.86	58.51	NB	18TH AVE BRIDGE SOUTH ABUTMENT
1	1517+10.20	-57.44	SB	18TH AVE BRIDGE SOUTH ABUTMENT
1	1518+42.20	60.08	NB	18TH AVE BRIDGE NORTH ABUTMENT
1	1518+34.38	-57.98	SB	18TH AVE BRIDGE NORTH ABUTMENT
1	1546+59.99	56.45	NB	7TH AVE BRIDGE SOUTH ABUTMENT
1	1546+62.42	-57.37	SB	7TH AVE BRIDGE SOUTH ABUTMENT
1	1547+85.22	60.74	NB	7TH AVE BRIDGE NORTH ABUTMENT
1	1547+82.54	-64.59	SB	7TH AVE BRIDGE NORTH ABUTMENT
1			NB	7TH AVE BRIDGE SOUTH SLOPEWALL
1			SB	7TH AVE BRIDGE SOUTH SLOPEWALL
1			NB	7TH AVE BRIDGE NORTH SLOPEWALL
1			SB	7TH AVE BRIDGE NORTH SLOPEWALL
20 TOTAL				

60100945 PIPE DRAINS 12"

FOOT	LOCATION	OFFSET	DIRECTION	REMARKS
45	1469+65.46		NB	SOUTH OF 31ST
56	1470+07.57		SB	SOUTH OF 31ST
53	1471+32.94		NB	NORTH OF 31ST
46	1471+75.75		SB	NORTH OF 31ST
50	1506+37.26		SB	SOUTH OF RR
50	1508+97.96		SB	NORTH OF RR
50	1516+93.85		SB	SOUTH OF 18TH
50	1518+53.87		SB	NORTH OF 18TH
45	1546+41.29		NB	SOUTH OF 7TH
45	1548+02.69		NB	NORTH OF 7TH
490 TOTAL				

PLT DATE * DATE *
FILE NAME * FILE #
USER NAME * USER #

REVISIONS	
NAME	DATE

ILLINOIS DEPARTMENT OF TRANSPORTATION

SCALE: NONE
DATE

DRAWN BY: JW
CHECKED BY: MGZ

SCHEDULE OF QUANTITIES

SCHEDULE OF QUANTITIES

F.A.P. RTE.	SECTION	COUNTY	TOTAL SHEETS	SHEET NO.
308	186/HB-1,VB/HB-2R	ROCK ISLAND	210	16
STA.		TO STA.		
FED. ROAD DIST. NO. 2		ILLINOIS FED. AID PROJECT		

60500050 REMOVING CATCH BASINS

EACH	LOCATION	OFFSET	DIRECTION	REMARKS
1	1486+58.50			
1	1487+58.80			
1	1501+83.40			
1	1511+46.90			
1	1514+17.50			
1	1514+94.10			
1	1515+71.30			
1	1520+10.60			
1	1540+57.30			
1	1542+55.30			
1	1552+26.00			
1	1552+99.00			
1	1553+72.00			
1	1556+53.50			
1	1559+56.60			
15 TOTAL				

60500205 FILLING CATCH BASINS

EACH	LOCATION	OFFSET	DIRECTION	REMARKS
1	1499+13.17	-39.28		
1	1501+91.75	-36.89		
1	1504+32.47	-39.32		
1	1511+38.74	-54.06		
1	1514+16.31	-89.84		
1	1519+95.20	-36.57		
1	1523+06.79	-38.17		
1	1543+56.62	39.22		
8 TOTAL				

60605000 COMBINATION CONCRETE CURB AND GUTTER, TYPE B-6.24

FOOT	LOCATION	OFFSET	DIRECTION	REMARKS
88	18TH AVE BRIDGE			SOUTH OF 18TH
88	18TH AVE BRIDGE			NORTH OF 18TH
87	7TH AVE BRIDGE			SOUTH OF 7TH
87	7TH AVE BRIDGE			NORTH OF 7TH
350 TOTAL				

60900315 TYPE D INLET BOX, STANDARD 609006

EACH	LOCATION	OFFSET	DIRECTION	REMARKS
1	1469+65.46	52.08	NB	SOUTH OF 31ST
1	1470+07.57	-52.08	SB	SOUTH OF 31ST
1	1471+32.94	52.08	NB	NORTH OF 31ST
1	1471+75.75	-52.08	SB	NORTH OF 31ST
1	1506+37.27	-43.08	SB	SOUTH OF RR
1	1508+97.96	-43.08	SB	NORTH OF RR
1	1516+93.86	-34.67	SB	SOUTH OF 18TH
1	1518+53.87	-34.84	SB	NORTH OF 18TH
1	1546+41.30	34.65	NB	SOUTH OF 7TH
1	1548+02.69	34.79	NB	NORTH OF 7TH
10 TOTAL				

60900515 CONCRETE THRUST BLOCKS

EACH	LOCATION	OFFSET	DIRECTION	REMARKS
1	1469+65.46		NB	SOUTH OF 31ST
1	1470+07.57		SB	SOUTH OF 31ST
1	1471+32.94		NB	NORTH OF 31ST
1	1471+75.75		SB	NORTH OF 31ST
1	1506+37.24		SB	SOUTH OF RR
1	1508+97.94		SB	NORTH OF RR
1	1516+93.69		SB	SOUTH OF 18TH
1	1518+53.92		SB	NORTH OF 18TH
1	1546+41.13		NB	SOUTH OF 7TH
1	1548+02.69		NB	NORTH OF 7TH
10 TOTAL				

63000000 STEEL PLATE BEAM GUARD RAIL, TYPE A

FOOT	LOCATION	OFFSET	DIRECTION	REMARKS
475	1464+64.78	TO 1469+39.78		OUTSIDE EOS NB 31ST
325	1466+90.36	TO 1470+15.36		OUTSIDE EOS SB 31ST
175	1467+82.64	TO 1469+57.54		INSIDE EOS NB 31ST
250	1471+25.26	TO 1473+75.26		OUTSIDE EOS NB 31ST
175	1471+83.09	TO 1473+57.99		INSIDE EOS SB 31ST
475	1472+00.85	TO 1476+75.85		OUTSIDE EOS SB 31ST
2350	1477+59.60	TO 1500+94.28		OUTSIDE EOS SB WETLANDS N. OF 31ST
212.5	1479+69.46	TO 1481+81.99		MEDIAN SIGN TRUSS
125	1480+56.75	TO 1481+81.99		MEDIAN SIGN TRUSS
600	1499+11.82	TO 1505+04.25		OUTSIDE EOS NB IAIS RR
525	1500+94.28	TO 1506+26.48		OUTSIDE EOS SB IAIS RR
25	1509+20.18	TO 1509+47.23		OUTSIDE EOS NB IAIS RR
450	1509+40.54	TO 1513+96.95		OUTSIDE EOS SB IAIS RR
300	1509+47.23	TO 1512+39.12		OUTSIDE EOS NB IAIS RR
225	1514+58.78	TO 1516+80.91		OUTSIDE EOS NB 18TH
262.5	1518+78.63	TO 1521+41.13		OUTSIDE EOS SB 18TH
225	1543+90.71	TO 1546+18.66		OUTSIDE EOS NB 7TH
225	1548+24.53	TO 1550+46.66		OUTSIDE EOS SB 7TH
7,400 TOTAL				

63000005 STEEL PLATE BEAM GUARD RAIL, TYPE B

FOOT	LOCATION	OFFSET	DIRECTION	REMARKS
125	1508+00.10	TO 1509+20.18		OUTSIDE EOS NB IAIS RR
125	1521+41.13	TO 1522+66.13		OUTSIDE EOS SB 18TH
250 TOTAL				

63000015 STEEL PLATE BEAM GUARD RAIL, TYPE D

FOOT	LOCATION	OFFSET	DIRECTION	REMARKS
312.5	1481+81.99	TO 1484+94.79		INSIDE EOS NB 31ST
312.5 TOTAL				

63100045 TRAFFIC BARRIER TERMINAL, TYPE 2

EACH	LOCATION	OFFSET	DIRECTION	REMARKS
1	1466+76.09	TO 1466+90.36		OUTSIDE EOS SB 31ST
1	1473+75.26	TO 1473+89.53		OUTSIDE EOS NB 31ST
1	1477+45.39	TO 1477+59.60		OUTSIDE EOS SB N. OF 31ST OFF-RAMP
1	1480+42.48	TO 1480+56.75		MEDIAN
1	1512+39.12	TO 1512+52.82		OUTSIDE EOS NB IAIS RR
5 TOTAL				

63100070 TRAFFIC BARRIER TERMINAL, TYPE 5

EACH	LOCATION	OFFSET	DIRECTION	REMARKS
1	1470+15.36	TO 1470+30.03		OUTSIDE EOS SB 31ST
1	1471+10.59	TO 1471+25.26		OUTSIDE EOS NB 31ST
1	1506+26.48	TO 1506+41.15		OUTSIDE EOS SB IAIS RR
1	1507+85.43	TO 1508+00.10		OUTSIDE EOS NB IAIS RR
4 TOTAL				

PLT DATE * #DATE*
 FILE NAME * #FILE#*
 USER NAME * #USER#*

REVISIONS		ILLINOIS DEPARTMENT OF TRANSPORTATION
NAME	DATE	
		SCALE: NONE DRAWN BY JW CHECKED BY MGZ

SCHEDULE OF QUANTITIES

SCHEDULE OF QUANTITIES

F.A.P. RTE.	SECTION	COUNTY	TOTAL SHEETS	SHEET NO.
30B	1H3,4B-1,6B,8B-2R	ROCKY ISLAND	210	17
STA.		TO STA.		
FED. ROAD DIST. NO. 2		ILLINOIS FED. AID PROJECT		

63100085 TRAFFIC BARRIER TERMINAL, TYPE 6

EACH	LOCATION	OFFSET	DIRECTION	REMARKS
1	1469+39.78 TO 1469+83.53	OUTSIDE EOS	NB	31ST
1	1469+57.54 TO 1470+01.29	INSIDE EOS	NB	31ST
1	1471+39.34 TO 1471+83.09	INSIDE EOS	SB	31ST
1	1471+57.10 TO 1472+00.85	OUTSIDE EOS	SB	31ST
1	1505+04.25 TO 1505+47.49	OUTSIDE EOS	NB	IAIS RR
1	1508+96.55 TO 1509+40.54	OUTSIDE EOS	SB	IAIS RR
1	1516+80.91 TO 1517+25.24	OUTSIDE EOS	NB	18TH
1	1518+34.98 TO 1518+78.63	OUTSIDE EOS	SB	18TH
1	1546+18.66 TO 1546+63.04	OUTSIDE EOS	NB	7TH
1	1547+80.52 TO 1548+24.53	OUTSIDE EOS	SB	7TH

10 TOTAL

63500105 DELINEATORS

EACH	LOCATION	OFFSET	DIRECTION	REMARKS
1	1464+14.78	OUTSIDE EOS	NB	
1	1467+32.56	INSIDE EOS	NB	
1	1474+07.99	INSIDE EOS	SB	
1	1477+25.85	OUTSIDE EOS	SB	
1	1479+19.46	INSIDE EOS	NB	SIGN TRUSS
1	1485+51.03	INSIDE EOS	SB	TYPE D GUARDRAIL
1	1485+51.03	INSIDE EOS	NB	TYPE D GUARDRAIL
1	1498+59.47	OUTSIDE EOS	NB	
1	1514+08.59	OUTSIDE EOS	NB	
1	1514+47.58	OUTSIDE EOS	SB	
1	1521+54.33	OUTSIDE EOS	SB	
1	1543+38.74	OUTSIDE EOS	NB	
1	1550+96.54	OUTSIDE EOS	SB	

13 TOTAL

63100089 TRAFFIC BARRIER TERMINAL, TYPE 6B

EACH	LOCATION	OFFSET	DIRECTION	REMARKS
1	1484+94.79 TO 1485+51.03	INSIDE EOS	SB	31ST
1	1484+94.79 TO 1485+51.03	INSIDE EOS	SB	31ST

2 TOTAL

63700255 CONCRETE BARRIER, DOUBLE FACE, 32 INCH HEIGHT

FOOT	LOCATION	OFFSET	SHEET	REMARKS
0	1451+00.00 TO 1457+00.00		SHEET 1	
0	1457+00.00 TO 1463+00.00		SHEET 2	
0	1463+00.00 TO 1469+00.00		SHEET 3	
0	1469+00.00 TO 1475+00.00		SHEET 4	
0	1475+00.00 TO 1481+00.00		SHEET 5	
149	1481+00.00 TO 1487+00.00		SHEET 6	
600	1487+00.00 TO 1493+00.00		SHEET 7	
600	1493+00.00 TO 1499+00.00		SHEET 8	
500	1499+00.00 TO 1504+00.00		SHEET 9	
311	1504+00.00 TO 1510+00.00		SHEET 10	
500	1510+00.00 TO 1515+00.00		SHEET 11	
366	1515+00.00 TO 1521+00.00		SHEET 12	
600	1521+00.00 TO 1527+00.00		SHEET 13	
600	1527+00.00 TO 1533+00.00		SHEET 14	
600	1533+00.00 TO 1539+00.00		SHEET 15	
600	1539+00.00 TO 1545+00.00		SHEET 16	
366	1545+00.00 TO 1551+00.00		SHEET 17	
600	1551+00.00 TO 1557+00.00		SHEET 18	
464	1557+00.00 TO 1561+63.55		SHEET 19	

6,856 TOTAL

63100167 TRAFFIC BARRIER TERMINAL TYPE 1, SPECIAL (TANGENT)

EACH	LOCATION	OFFSET	DIRECTION	REMARKS
1	1464+14.78 TO 1464+64.78	OUTSIDE EOS	NB	31ST
1	1467+32.64 TO 1467+82.64	INSIDE EOS	NB	31ST
1	1473+57.99 TO 1474+07.99	INSIDE EOS	SB	31ST
1	1476+75.85 TO 1477+25.85	OUTSIDE EOS	SB	31ST
1	1479+19.46 TO 1479+69.46	MEDIAN		N. OF 31ST
1	1498+62.07 TO 1499+11.82	OUTSIDE EOS	NB	IAIS RR
1	1513+96.95 TO 1514+45.25	OUTSIDE EOS	SB	IAIS RR
1	1514+09.44 TO 1514+58.78	OUTSIDE EOS	NB	18TH
1	1522+66.13 TO 1523+16.13	OUTSIDE EOS	SB	18TH
1	1543+40.06 TO 1543+90.71	OUTSIDE EOS	NB	7TH
1	1550+46.66 TO 1550+96.01	OUTSIDE EOS	SB	7TH

11 TOTAL

63801205 TEMPORARY MODULAR GLARE SCREEN

FOOT	LOCATION	OFFSET	DIRECTION	REMARKS
500	1456+00.00 TO 1461+00.00		SB	
300	1556+00.00 TO 1559+00.00		SB	
350	1556+50.00 TO 1560+00.00		NB	

1,150 TOTAL

63200310 GUARDRAIL REMOVAL

FOOT	LOCATION	OFFSET	DIRECTION	REMARKS
433	1465+50.36 TO 1469+82.93	OUTSIDE EOS	NB	
363	1466+67.21 TO 1470+30.03	OUTSIDE EOS	SB	
137	1468+65.57 TO 1470+00.61	INSIDE EOS	NB	
349	1471+10.59 TO 1474+59.85	OUTSIDE EOS	NB	
110	1471+39.94 TO 1472+49.17	INSIDE EOS	SB	
382	1471+57.70 TO 1475+39.13	OUTSIDE EOS	SB	
572	1477+85.95 TO 1483+46.31	OUTSIDE EOS	SB	
637	1479+14.95 TO 1485+51.03	INSIDE EOS	NB	
725	1499+05.27 TO 1506+39.82	OUTSIDE EOS	SB	
341	1502+08.09 TO 1505+44.25	OUTSIDE EOS	NB	
431	1507+85.03 TO 1512+04.16	OUTSIDE EOS	NB	
532	1508+99.05 TO 1514+32.07	OUTSIDE EOS	SB	
321	1514+06.62 TO 1517+22.66	OUTSIDE EOS	NB	
480	1518+33.76 TO 1523+15.63	OUTSIDE EOS	SB	
303	1543+54.74 TO 1546+61.05	OUTSIDE EOS	NB	
235	1547+82.46 TO 1550+13.88	OUTSIDE EOS	SB	
289.5	1471+33.00 TO 1474+01.00	LT EOS	SB	STAGE 3
289.5	1467+77.00 TO 1470+30.00	RT EOS	NB	STAGE 4

6,930 TOTAL

66700305 PERMANENT SURVEY MARKERS, TYPE II

EACH	LOCATION	OFFSET	DIRECTION	REMARKS
1	31ST AVE BRIDGE			
1	RR BRIDGE			
1	18TH AVE BRIDGE			
1	7TH AVE BRIDGE			

4 TOTAL

PLOT DATE * * * * *
FILE NAME * * * * *
PLOT SCALE * * * * *
USER NAME * * * * *

REVISIONS		ILLINOIS DEPARTMENT OF TRANSPORTATION
NAME	DATE	
		SCALE: NONE DATE DRAWN BY JW CHECKED BY MGZ

SCHEDULE OF QUANTITIES

F.A.P. RTE.	SECTION	COUNTY	TOTAL SHEETS	SHEET NO.
308	10R/RB-1,VB/RB-2R	ROCK ISLAND	210	19
STA.	TO STA.			
FED. ROAD DIST. NO. 2 ILLINOIS			FED. AID PROJECT	

70300220 TEMPORARY PAVEMENT MARKING - LINE 4" (SEE PREVIOUS SHEET FOR CONTINUATION)

70300220 TEMPORARY PAVEMENT MARKING - LINE 4" (SEE BOTTOM LEFT FOR CONTINUATION)

FOOT	LOCATION	OFFSET	REMARKS
181	1457+07.34 TO 1458+86.54	NB RTEOP	SOLID WHITE - STAGE 3
83	1458+86.54 TO 1459+69.56	SB RTEOP	SOLID WHITE - STAGE 3
139	1457+39.96 TO 1462+97.00	SB RTEOP	WHITE SKIP DASH - STAGE 3
636	1457+31.36 TO 1463+66.81	NB RTEOP	SOLID WHITE - STAGE 3
869	1455+00.00 TO 1463+67.57	NB LTEOP	SOLID YELLOW - STAGE 3
755	1457+39.96 TO 1464+94.40	SB RTEOP	SOLID WHITE - STAGE 3
189	1464+94.40 TO 1466+77.91	SB RTEOP	SOLID WHITE - STAGE 3
392	1462+97.00 TO 1466+83.43	SB LTEOP	SOLID YELLOW - STAGE 3
165	1474+70.71 TO 1476+30.04	NB RTEOP	SOLID WHITE - STAGE 3
1,585	1462+97.00 TO 1478+81.95	SB RTEOP	SOLID WHITE - STAGE 3
1,912	1459+69.56 TO 1478+81.95	SB RTEOP	SOLID WHITE - STAGE 3
276	1476+30.04 TO 1479+06.08	NB RTEOP	SOLID WHITE - STAGE 3
202	1477+08.60 TO 1479+09.48	SB RTEOP	SOLID WHITE - STAGE 3
197	1478+81.95 TO 1480+76.89	SB RTEOP	SOLID WHITE - STAGE 3
374	1477+07.23 TO 1480+76.89	SB LTEOP	SOLID YELLOW - STAGE 3
52	1480+76.89 TO 1482+81.75	SB RTEOP	WHITE SKIP DASH - STAGE 3
380	1479+09.48 TO 1482+81.75	SB RTEOP	SOLID WHITE - STAGE 3
746	1479+06.08 TO 1486+61.25	NB RTEOP	SOLID WHITE - STAGE 3
868	1478+81.95 TO 1487+45.87	SB RTEOP	SOLID WHITE - STAGE 3
1,282	1474+64.76 TO 1487+45.87	NB LTEOP	SOLID YELLOW - STAGE 3
487	1482+81.75 TO 1487+62.81	SB RTEOP	SOLID WHITE - STAGE 3
155	1486+61.25 TO 1488+16.31	NB RTEOP	SOLID WHITE - STAGE 3
82	1487+45.87 TO 1490+75.00	SB RTEOP	WHITE SKIP DASH - STAGE 3
259	1488+16.31 TO 1490+75.00	NB RTEOP	SOLID WHITE - STAGE 3
816	1490+75.00 TO 1498+91.16	SB RTEOP	SOLID WHITE - STAGE 3
1,129	1487+62.81 TO 1498+91.16	SB RTEOP	SOLID WHITE - STAGE 3
822	1498+91.16 TO 1507+23.08	SB RTEOP	SOLID WHITE - STAGE 3
505	1507+23.08 TO 1512+35.42	SB RTEOP	SOLID WHITE - STAGE 3
143	1507+23.08 TO 1513+00.14	SB RTEOP	WHITE SKIP DASH - STAGE 3
203	1512+35.42 TO 1514+37.46	SB RTEOP	SOLID WHITE - STAGE 3
145	1513+00.14 TO 1514+42.59	SB LTEOP	SOLID YELLOW - STAGE 3
2,125	1498+91.16 TO 1520+21.82	SB RTEOP	SOLID WHITE - STAGE 3
713	1513+00.14 TO 1520+21.82	SB RTEOP	SOLID WHITE - STAGE 3
660	1520+21.82 TO 1526+82.17	SB RTEOP	SOLID WHITE - STAGE 3
303	1523+79.79 TO 1526+82.17	SB LTEOP	SOLID YELLOW - STAGE 3
60	1526+82.17 TO 1529+22.96	SB RTEOP	WHITE SKIP DASH - STAGE 3
543	1523+80.60 TO 1529+22.96	SB RTEOP	SOLID WHITE - STAGE 3
634	1529+22.96 TO 1535+57.17	SB RTEOP	SOLID WHITE - STAGE 3
451	1535+57.17 TO 1540+08.01	SB RTEOP	SOLID WHITE - STAGE 3
2,012	1520+21.82 TO 1540+34.15	SB RTEOP	SOLID WHITE - STAGE 3
134	1535+57.17 TO 1540+92.31	SB RTEOP	WHITE SKIP DASH - STAGE 3
289	1540+08.01 TO 1542+90.12	SB RTEOP	SOLID WHITE - STAGE 3
205	1540+92.31 TO 1542+92.57	SB LTEOP	SOLID YELLOW - STAGE 3
97	1551+51.64 TO 1552+49.46	NB RTEOP	SOLID WHITE - STAGE 3
229	1552+49.46 TO 1554+82.26	NB RTEOP	SOLID WHITE - STAGE 3
1,512	1540+92.31 TO 1555+86.71	SB RTEOP	SOLID WHITE - STAGE 3
307	1552+84.89 TO 1555+86.71	SB LTEOP	SOLID YELLOW - STAGE 3
1,668	1540+34.15 TO 1556+97.50	SB RTEOP	SOLID WHITE - STAGE 3
448	1552+86.07 TO 1557+25.11	SB RTEOP	SOLID WHITE - STAGE 3
83	1556+97.50 TO 1557+80.40	SB RTEOP	SOLID WHITE - STAGE 3
78	1555+86.71 TO 1558+96.53	SB RTEOP	WHITE SKIP DASH - STAGE 3
174	1557+25.11 TO 1558+96.53	SB RTEOP	SOLID WHITE - STAGE 3
215	1557+80.39 TO 1559+94.68	SB RTEOP	SOLID WHITE - STAGE 3
22	1559+94.68 TO 1560+16.77	NB RTEOP	SOLID WHITE - STAGE 3
38	1560+16.77 TO 1560+54.49	NB RTEOP	SOLID WHITE - STAGE 3
940	1551+47.94 TO 1560+96.14	NB LTEOP	SOLID YELLOW - STAGE 3
607	1554+82.26 TO 1560+96.75	NB RTEOP	SOLID WHITE - STAGE 3
145	1560+54.49 TO 1562+00.00	NB RTEOP	SOLID WHITE - STAGE 3
102	1560+96.75 TO 1562+00.00	NB RTEOP	SOLID WHITE - STAGE 3
13,110	1431+00.00 TO 1562+00.00	NB LTEOP	SOLID YELLOW - STAGE 3
340	1558+96.53 TO 1562+32.18	SB RTEOP	SOLID WHITE - STAGE 3
91	1562+32.18 TO 1563+23.56	SB RTEOP	SOLID WHITE - STAGE 3
177	1563+23.56 TO 1565+00.00	SB RTEOP	SOLID WHITE - STAGE 3

SEE TOP RIGHT FOR CONTINUATION

FOOT	LOCATION	OFFSET	REMARKS
1,400	1565+00.00 TO 1579+00.00	SB RTEOP	SOLID WHITE - STAGE 3
1,823	1460+00.00 TO 1478+22.99	NB RTEOP	SOLID WHITE - STAGE 4
1,254	1466+00.00 TO 1478+54.14	SB RTEOP	SOLID WHITE - STAGE 4
273	1478+54.14 TO 1481+24.15	SB RTEOP	SOLID WHITE - STAGE 4
63	1481+24.15 TO 1483+73.95	SB RTEOP	WHITE SKIP DASH - STAGE 4
155	1478+22.99 TO 1484+51.43	NB RTEOP	WHITE SKIP DASH - STAGE 4
381	1483+73.95 TO 1487+51.26	SB RTEOP	SOLID WHITE - STAGE 4
405	1484+51.43 TO 1488+59.67	NB RTEOP	SOLID WHITE - STAGE 4
1,140	1487+51.26 TO 1498+91.16	SB RTEOP	SOLID WHITE - STAGE 4
1,032	1488+59.67 TO 1498+91.16	NB RTEOP	SOLID WHITE - STAGE 4
423	1498+91.16 TO 1503+18.33	SB RTEOP	SOLID WHITE - STAGE 4
924	1498+91.16 TO 1508+06.16	NB RTEOP	SOLID WHITE - STAGE 4
49	1508+06.16 TO 1509+99.70	SB RTEOP	WHITE SKIP DASH - STAGE 4
189	1503+18.33 TO 1510+82.54	NB RTEOP	WHITE SKIP DASH - STAGE 4
1,032	1509+99.70 TO 1520+21.82	NB RTEOP	SOLID WHITE - STAGE 4
930	1510+82.54 TO 1520+21.82	SB RTEOP	SOLID WHITE - STAGE 4
513	1520+21.82 TO 1525+34.88	NB RTEOP	SOLID WHITE - STAGE 4
778	1520+21.82 TO 1527+99.61	SB RTEOP	SOLID WHITE - STAGE 4
187	1525+34.88 TO 1532+83.11	NB RTEOP	WHITE SKIP DASH - STAGE 4
177	1532+83.11 TO 1534+60.55	NB RTEOP	SOLID WHITE - STAGE 4
81	1534+60.55 TO 1537+85.74	NB RTEOP	WHITE SKIP DASH - STAGE 4
255	1527+99.61 TO 1538+17.91	SB RTEOP	WHITE SKIP DASH - STAGE 4
248	1537+85.74 TO 1540+34.15	NB RTEOP	SOLID WHITE - STAGE 4
216	1538+17.91 TO 1540+34.15	SB RTEOP	SOLID WHITE - STAGE 4
1,513	1540+34.15 TO 1555+61.55	NB RTEOP	SOLID WHITE - STAGE 4
1,672	1540+34.15 TO 1556+90.97	SB RTEOP	SOLID WHITE - STAGE 4
83	1556+90.97 TO 1560+18.73	SB RTEOP	WHITE SKIP DASH - STAGE 4
132	1555+61.55 TO 1560+96.24	NB RTEOP	WHITE SKIP DASH - STAGE 4
216	1560+18.73 TO 1562+32.18	SB RTEOP	SOLID WHITE - STAGE 4
135	1560+96.24 TO 1562+32.18	NB RTEOP	SOLID WHITE - STAGE 4
68	1562+32.18 TO 1563+00.00	NB RTEOP	SOLID WHITE - STAGE 4
10,294	1460+00.00 TO 1563+00.00	NB LTEOP	SOLID YELLOW - STAGE 4
1,168	1562+32.18 TO 1574+00.00	SB RTEOP	SOLID WHITE - STAGE 4
10,808	1466+00.00 TO 1574+00.00	SB LTEOP	SOLID YELLOW - STAGE 4
150	24+40.00 TO 25+90.00		22 to 12
150	27+00.00 TO 28+50.00		-12 to -22
100	25+90.00 TO 26+90.00		12
100	26+00.00 TO 27+00.00		-12
51	26+90.00 TO 27+40.00		12 to 22
51	25+50.00 TO 26+00.00		-22 to -12
91	13+60.00 TO 14+50.00		22 to 12
91	15+50.00 TO 16+40.00		-12 to -22
100	14+50.00 TO 15+50.00		12
100	14+50.00 TO 15+50.00		-12
51	15+50.00 TO 16+00.00		12 to 22
51	14+00.00 TO 14+50.00		-22 to -12

197,612 TOTAL

70301000 WORK ZONE PAVEMENT MARKING REMOVAL

SQ FT	LOCATION	OFFSET	REMARKS
11,360	STAGE 1		
20,746	STAGE 2		
20,525	STAGE 3		
12,871	STAGE 4		
201	18TH AVE		
161	7TH AVE		

65,864 TOTAL

REVISIONS		ILLINOIS DEPARTMENT OF TRANSPORTATION
NAME	DATE	

SCALE: NONE
DATE: _____ DRAWN BY: JW
CHECKED BY: MGZ

PLOT DATE * * * * *
FILE NAME * * * * *
USER NAME * * * * *

SCHEDULE OF QUANTITIES

F.A.P. RTE.	SECTION	COUNTY	TOTAL SHEETS	SHEET NO.
308	1000HB-1,VB,HB-2R	ROCK ISLAND	210	20
STA.		TO STA.		
FED. ROAD DIST. NO. 2 ILLINOIS FED. AID PROJECT				

70500100 TEMPORARY STEEL PLATE BEAM GUARD RAIL, TYPE A

FOOT	LOCATION	OFFSET	DIRECTION	REMARKS
262.5	1471+33.00	TO 1474+01.00	LT EOS	STAGE 1
262.5	1467+77.00	TO 1470+30.00	RT EOS	STAGE 2
525 TOTAL				

78001110 PAINT PAVEMENT MARKING - LINE 4"

FOOT	LOCATION	OFFSET	REMARKS
3125	1454+00.00	TO 1579+00.00	SB RTEOP WHITE SKIP-DASHED
3352	1431+00.00	TO 1464+49.99	SB RTEOP SOLID WHITE
89	1463+62.94	TO 1464+51.75	NB RTEOP SOLID WHITE
1283	1454+00.00	TO 1466+76.55	NB LTEOP SOLID YELLOW
91	1465+97.73	TO 1466+83.50	SB RTEOP SOLID WHITE
78	1474+63.71	TO 1475+37.98	SB LTEOP SOLID YELLOW
1303	1463+62.85	TO 1476+62.06	NB LTEOP SOLID YELLOW
1358	1464+22.97	TO 1477+76.99	NB RTEOP SOLID WHITE
71	1477+06.94	TO 1477+77.97	SB RTEOP SOLID WHITE
2982	1454+00.00	TO 1483+79.84	SB LTEOP SOLID YELLOW
3789	1474+70.81	TO 1512+48.34	SB LTEOP SOLID YELLOW
53	1512+00.01	TO 1512+51.68	NB RTEOP SOLID WHITE
3727	1477+09.56	TO 1514+36.89	NB LTEOP SOLID YELLOW
76	1513+68.38	TO 1514+42.68	SB RTEOP SOLID WHITE
84	1521+75.66	TO 1522+56.62	SB LTEOP SOLID YELLOW
1219	1512+01.25	TO 1524+08.51	NB LTEOP SOLID YELLOW
1234	1511+95.03	TO 1524+33.12	NB RTEOP SOLID WHITE
55	1523+79.68	TO 1524+34.12	SB RTEOP SOLID WHITE
11065	1431+00.00	TO 1541+65.86	SB LTEOP SOLID YELLOW
2085	1521+80.99	TO 1542+65.21	NB RTEOP SOLID YELLOW
80	1541+85.85	TO 1542+67.26	NB LTEOP SOLID YELLOW
1917	1523+81.14	TO 1542+89.95	SB RTEOP SOLID WHITE
88	1542+07.13	TO 1542+92.72	SB LTEOP SOLID YELLOW
6380	1483+79.09	TO 1547+59.32	SB LTEOP SOLID YELLOW
988	1541+66.52	TO 1551+55.82	NB LTEOP SOLID YELLOW
75	1551+48.35	TO 1552+23.25	NB LTEOP SOLID YELLOW
1359	1540+16.69	TO 1553+59.22	SB RTEOP SOLID WHITE
78	1552+83.56	TO 1553+59.49	SB LTEOP SOLID YELLOW
1227	1541+87.21	TO 1554+21.86	NB RTEOP SOLID WHITE
3300	1431+00.00	TO 1563+00.00	NB RTEOP WHITE SKIP-DASHED
1142	1551+56.58	TO 1563+00.00	NB LTEOP SOLID YELLOW
1136	1551+51.76	TO 1563+00.38	NB RTEOP SOLID WHITE
2629	1552+85.43	TO 1579+00.00	SB RTEOP SOLID WHITE
3141	1547+59.32	TO 1579+00.00	SB LTEOP SOLID YELLOW
189	14+05.81	TO 15+94.49	31ST AVE SOLID YELLOW
189	14+05.81	TO 15+94.49	31ST AVE SOLID YELLOW
189	14+05.81	TO 15+94.49	31ST AVE YELLOW SKIP-DASHED
74	26+10.94	TO 26+84.99	18TH AVE YELLOW SKIP-DASHED
74	14+63.72	TO 15+37.72	7TH AVE YELLOW SKIP-DASHED
61,374			
122,748 TOTAL (DOUBLE COAT)			

78001140 PAINT PAVEMENT MARKING - LINE 8"

FOOT	LOCATION	OFFSET	REMARKS
737	1463+62.85	TO 1463+63.00	NB RTEOP SOLID WHITE
41	1462+49.12	TO 1464+11.78	SB RTEOP WHITE SKIP-DASHED
176	1464+22.97	TO 1465+97.73	SB RTEOP SOLID WHITE
126	1475+37.98	TO 1476+62.06	NB RTEOP SOLID WHITE
704	1477+76.99	TO 1477+77.97	SB RTEOP SOLID WHITE
50	1476+62.05	TO 1478+61.57	NB RTEOP WHITE SKIP-DASHED
34	1510+83.34	TO 1511+95.03	SB RTEOP WHITE SKIP-DASHED
409	1512+00.98	TO 1512+01.25	NB RTEOP SOLID WHITE
173	1511+95.03	TO 1513+68.99	SB RTEOP SOLID WHITE
153	1522+55.81	TO 1524+08.11	NB RTEOP SOLID WHITE
733	1524+33.12	TO 1524+34.12	SB RTEOP SOLID WHITE
32	1524+20.72	TO 1525+47.07	NB RTEOP WHITE SKIP-DASHED
50	1538+17.91	TO 1540+16.69	SB RTEOP WHITE SKIP-DASHED
799	1541+86.41	TO 1541+87.21	NB RTEOP SOLID WHITE
193	1540+16.69	TO 1542+07.13	SB RTEOP SOLID WHITE
671	1553+59.22	TO 1553+59.49	SB RTEOP SOLID WHITE
197	1552+22.95	TO 1554+21.86	NB RTEOP SOLID WHITE
35	1554+21.86	TO 1555+61.56	NB RTEOP WHITE SKIP-DASHED
5,312			
10,623 TOTAL (DOUBLE COAT)			

78001150 PAINT PAVEMENT MARKING - LINE 12"

FOOT	LOCATION	OFFSET	REMARKS
198	1460+14.68	TO 1463+76.34	RT NB 31ST AVE EXIT RAMP - GORE
177	1477+79.24	TO 1481+05.61	LT SB 31ST AVE EXIT RAMP - GORE
109	1510+31.58	TO 1512+14.28	RT NB 18TH AVE EXIT RAMP - GORE
177	1524+37.39	TO 1527+97.76	LT SB 18TH AVE EXIT RAMP - GORE
210	1538+15.87	TO 1541+77.18	RT NB 7TH AVE EXIT RAMP - GORE
156	1553+56.10	TO 1556+86.80	LT SB 7TH AVE EXIT RAMP - GORE
1,027			
2,055 TOTAL (DOUBLE COAT)			

PLOT DATE : #DATE#
 FILE NAME : #FILE#
 SOURCE : #SCHED#
 USER NAME : #USER#

REVISIONS		ILLINOIS DEPARTMENT OF TRANSPORTATION
NAME	DATE	
SCALE: NONE	DRAWN BY	JW
DATE	CHECKED BY	MGZ

SCHEDULE OF QUANTITIES

F.A.P. RTE.	SECTION	COUNTY	TOTAL SHEETS	SHEET NO.
308	10B,11B-1,10B,11B-2R	ROCK ISLAND	210	21
STA.	TO STA.			
FED. ROAD DIST. NO. 2 ILLINOIS		FED. AID PROJECT		

SCHEDULE OF QUANTITIES

78200410 GUARDRAIL MARKERS, TYPE A

EACH	LOCATION	OFFSET	DIRECTION	COLOR	REMARKS
1	1464+93.92	OUTSIDE EOS	NB	SILVER	
1	1465+73.92	OUTSIDE EOS	NB	SILVER	
1	1466+53.92	OUTSIDE EOS	NB	SILVER	
1	1466+76.09	OUTSIDE EOS	SB	SILVER	
1	1467+33.92	OUTSIDE EOS	NB	SILVER	
1	1468+11.69	INSIDE EOS	NB	AMBER	
1	1468+13.92	OUTSIDE EOS	NB	SILVER	
1	1468+91.64	INSIDE EOS	NB	AMBER	
1	1469+25.01	OUTSIDE EOS	SB	SILVER	
1	1469+71.61	INSIDE EOS	NB	AMBER	
1	1471+82.99	INSIDE EOS	NB	AMBER	TYPE D GUARDRAIL
1	1471+83.06	INSIDE EOS	SB	AMBER	TYPE D GUARDRAIL
1	1472+13.92	OUTSIDE EOS	NB	SILVER	
1	1473+25.01	OUTSIDE EOS	SB	SILVER	
1	1473+49.96	INSIDE EOS	NB	AMBER	TYPE D GUARDRAIL
1	1473+50.40	INSIDE EOS	SB	AMBER	TYPE D GUARDRAIL
1	1473+75.26	OUTSIDE EOS	NB	SILVER	
1	1474+05.01	OUTSIDE EOS	SB	SILVER	
1	1474+85.01	OUTSIDE EOS	SB	SILVER	
1	1475+65.01	OUTSIDE EOS	SB	SILVER	
1	1476+45.01	OUTSIDE EOS	SB	SILVER	
1	1477+43.73	OUTSIDE EOS	SB	SILVER	TYPE D GUARDRAIL
1	1477+49.85	INSIDE EOS	NB	AMBER	TYPE D GUARDRAIL
1	1477+50.28	INSIDE EOS	SB	AMBER	
1	1478+44.77	OUTSIDE EOS	SB	SILVER	
1	1481+49.97	INSIDE EOS	NB	AMBER	TYPE D GUARDRAIL
1	1481+50.25	INSIDE EOS	SB	AMBER	TYPE D GUARDRAIL
1	1482+30.01	INSIDE EOS	NB	AMBER	TYPE D GUARDRAIL
1	1482+30.23	INSIDE EOS	SB	AMBER	TYPE D GUARDRAIL
1	1482+36.16	OUTSIDE EOS	SB	SILVER	
1	1483+10.06	INSIDE EOS	NB	AMBER	TYPE D GUARDRAIL
1	1483+10.22	INSIDE EOS	SB	AMBER	TYPE D GUARDRAIL
1	1483+90.10	INSIDE EOS	NB	AMBER	TYPE D GUARDRAIL
1	1483+90.21	INSIDE EOS	SB	AMBER	TYPE D GUARDRAIL
1	1484+70.15	INSIDE EOS	NB	AMBER	TYPE D GUARDRAIL
1	1484+70.21	INSIDE EOS	SB	AMBER	TYPE D GUARDRAIL
1	1486+29.34	OUTSIDE EOS	SB	SILVER	
1	1490+27.08	OUTSIDE EOS	SB	SILVER	
1	1494+27.08	OUTSIDE EOS	SB	SILVER	
1	1498+27.08	OUTSIDE EOS	SB	SILVER	
1	1499+38.03	OUTSIDE EOS	NB	SILVER	
1	1500+17.00	OUTSIDE EOS	NB	SILVER	
1	1500+95.98	OUTSIDE EOS	NB	SILVER	
1	1501+74.95	OUTSIDE EOS	NB	SILVER	
1	1502+31.46	OUTSIDE EOS	SB	SILVER	
1	1502+53.92	OUTSIDE EOS	NB	SILVER	
1	1506+37.14	OUTSIDE EOS	SB	SILVER	
1	1510+42.52	OUTSIDE EOS	NB	SILVER	
1	1510+43.58	OUTSIDE EOS	SB	SILVER	
1	1511+25.06	OUTSIDE EOS	SB	SILVER	
1	1512+06.59	OUTSIDE EOS	SB	SILVER	
1	1512+52.85	OUTSIDE EOS	NB	SILVER	
1	1512+88.11	OUTSIDE EOS	SB	SILVER	
1	1513+68.71	OUTSIDE EOS	SB	SILVER	
1	1514+86.74	OUTSIDE EOS	NB	SILVER	
1	1515+65.72	OUTSIDE EOS	NB	SILVER	
1	1516+44.71	OUTSIDE EOS	NB	SILVER	
1	1519+12.14	OUTSIDE EOS	SB	SILVER	
1	1519+93.20	OUTSIDE EOS	SB	SILVER	
1	1520+73.57	OUTSIDE EOS	SB	SILVER	
1	1544+18.96	OUTSIDE EOS	NB	SILVER	
1	1545+00.00	OUTSIDE EOS	NB	SILVER	
1	1545+81.04	OUTSIDE EOS	NB	SILVER	
1	1548+58.78	OUTSIDE EOS	SB	SILVER	
1	1549+37.76	OUTSIDE EOS	SB	SILVER	
1	1550+16.74	OUTSIDE EOS	SB	SILVER	

66 TOTAL

78200420 GUARDRAIL MARKERS, TYPE B

EACH	LOCATION	OFFSET	DIRECTION	COLOR	REMARKS
1	31ST BRIDGE	OUTSIDE EOS	NB	SILVER	BEGINNING OF BRIDGE
1	31ST BRIDGE	OUTSIDE EOS	NB	SILVER	MIDDLE OF BRIDGE
1	31ST BRIDGE	OUTSIDE EOS	NB	SILVER	END OF BRIDGE
1	31ST BRIDGE	INSIDE EOS	NB	AMBER	BEGINNING OF BRIDGE
1	31ST BRIDGE	INSIDE EOS	NB	AMBER	MIDDLE OF BRIDGE
1	31ST BRIDGE	INSIDE EOS	NB	AMBER	END OF BRIDGE
1	31ST BRIDGE	OUTSIDE EOS	SB	SILVER	BEGINNING OF BRIDGE
1	31ST BRIDGE	OUTSIDE EOS	SB	SILVER	MIDDLE
1	31ST BRIDGE	OUTSIDE EOS	SB	SILVER	END OF BRIDGE
1	31ST BRIDGE	INSIDE EOS	SB	AMBER	BEGINNING OF BRIDGE
1	31ST BRIDGE	INSIDE EOS	SB	AMBER	MIDDLE OF BRIDGE
1	31ST BRIDGE	INSIDE EOS	SB	AMBER	END OF BRIDGE
1	RR BRIDGE	OUTSIDE EOS	SB	SILVER	BEGINNING OF BRIDGE
1	RR BRIDGE	OUTSIDE EOS	SB	SILVER	MIDDLE OF BRIDGE
1	RR BRIDGE	OUTSIDE EOS	SB	SILVER	END OF BRIDGE
1	RR BRIDGE	OUTSIDE EOS	NB	SILVER	BEGINNING OF BRIDGE
1	RR BRIDGE	OUTSIDE EOS	NB	SILVER	MIDDLE OF BRIDGE
1	RR BRIDGE	OUTSIDE EOS	NB	SILVER	END OF BRIDGE
1	18TH BRIDGE	OUTSIDE EOS	NB	SILVER	BEGINNING OF BRIDGE
1	18TH BRIDGE	OUTSIDE EOS	NB	SILVER	MIDDLE OF BRIDGE
1	18TH BRIDGE	OUTSIDE EOS	NB	SILVER	END OF BRIDGE
1	18TH BRIDGE	OUTSIDE EOS	SB	SILVER	BEGINNING OF BRIDGE
1	18TH BRIDGE	OUTSIDE EOS	SB	SILVER	MIDDLE OF BRIDGE
1	18TH BRIDGE	OUTSIDE EOS	SB	SILVER	END OF BRIDGE
1	7TH BRIDGE	OUTSIDE EOS	NB	SILVER	BEGINNING OF BRIDGE
1	7TH BRIDGE	OUTSIDE EOS	NB	SILVER	MIDDLE OF BRIDGE
1	7TH BRIDGE	OUTSIDE EOS	NB	SILVER	END OF BRIDGE
1	7TH BRIDGE	OUTSIDE EOS	SB	SILVER	BEGINNING OF BRIDGE
1	7TH BRIDGE	OUTSIDE EOS	SB	SILVER	MIDDLE OF BRIDGE
1	7TH BRIDGE	OUTSIDE EOS	SB	SILVER	END OF BRIDGE

30 TOTAL

78201000 TERMINAL MARKER - DIRECT APPLIED

EACH	LOCATION	OFFSET	DIRECTION	REMARKS
1	1464+14.78 TO	1464+64.78	OUTSIDE EOS NB	31ST
1	1467+32.64 TO	1467+82.64	INSIDE EOS NB	31ST
1	1473+57.99 TO	1474+07.99	INSIDE EOS SB	31ST
1	1476+75.85 TO	1477+25.85	OUTSIDE EOS SB	31ST
1	1479+19.46 TO	1479+69.46	MEDIAN	N. OF 31ST
1	1498+62.07 TO	1499+11.82	OUTSIDE EOS NB	IAIS RR
1	1513+96.95 TO	1514+45.25	OUTSIDE EOS SB	IAIS RR
1	1514+09.44 TO	1514+58.78	OUTSIDE EOS NB	18TH
1	1522+66.13 TO	1523+16.13	OUTSIDE EOS SB	18TH
1	1543+40.06 TO	1543+90.71	OUTSIDE EOS NB	7TH
1	1550+46.66 TO	1550+96.01	OUTSIDE EOS SB	7TH
1	1474+01.00		LT EOS SB	STAGE 1
1	1467+77.00		RT EOS NB	STAGE 2

13 TOTAL

PLT DATE = 8/24/08
 FILE NAME = 8/11/08
 USER = USER

REVISIONS		ILLINOIS DEPARTMENT OF TRANSPORTATION
NAME	DATE	

SCALE: NONE
 DATE: DRAWN BY: JW
 CHECKED BY: MGZ

SCHEDULE OF QUANTITIES

F.A.P. RTE.	SECTION	COUNTY	TOTAL SHEETS	SHEET NO.
308	108+HB-1,VB,HB-2R	ROCK ISLAND	210	22
STA.		TO STA.		
FED. ROAD DIST. NO. 2 ILLINOIS FED. AID PROJECT				

SCHEDULE OF QUANTITIES

78300100 PAVEMENT MARKING REMOVAL

SQ FT	LOCATION	OFFSET	REMARKS
3125	1454+00.00 TO 1579+00.00	SB RTEOP	WHITE SKIP-DASHED 4"
3300	1431+00.00 TO 1563+00.00	NB RTEOP	WHITE SKIP-DASHED 4"
1358	1464+22.97 TO 1477+76.99	SB RTEOP	SOLID WHITE 4"
1234	1511+95.03 TO 1524+33.12	SB RTEOP	SOLID WHITE 4"
1359	1540+16.69 TO 1553+59.22	SB RTEOP	SOLID WHITE 4"
2085	1521+80.99 TO 1542+65.21	NB RTEOP	SOLID WHITE 4"
1219	1512+01.25 TO 1524+08.51	NB RTEOP	SOLID WHITE 4"
2629	1552+85.43 TO 1579+00.00	SB RTEOP	SOLID WHITE 4"
1283	1454+00.00 TO 1466+76.55	SB RTEOP	SOLID WHITE 4"
1136	1551+51.76 TO 1563+00.38	NB RTEOP	SOLID WHITE 4"
3352	1431+00.00 TO 1464+49.99	NB RTEOP	SOLID WHITE 4"
1917	1523+81.14 TO 1542+89.95	SB RTEOP	SOLID WHITE 4"
3789	1474+70.81 TO 1512+48.34	NB RTEOP	SOLID WHITE 4"
3727	1477+09.56 TO 1514+36.89	SB RTEOP	SOLID WHITE 4"
1227	1541+87.21 TO 1554+21.86	NB RTEOP	SOLID WHITE 4"
1303	1463+62.85 TO 1476+62.06	NB RTEOP	SOLID WHITE 4"
91	1465+97.73 TO 1466+83.50	SB LTEOP	SOLID YELLOW 4"
71	1477+06.94 TO 1477+77.97	SB LTEOP	SOLID YELLOW 4"
76	1513+68.38 TO 1514+42.68	SB LTEOP	SOLID YELLOW 4"
88	1542+07.13 TO 1542+92.72	SB LTEOP	SOLID YELLOW 4"
75	1551+48.35 TO 1552+23.25	NB LTEOP	SOLID YELLOW 4"
55	1523+79.68 TO 1524+34.12	SB LTEOP	SOLID YELLOW 4"
84	1521+75.66 TO 1522+56.62	NB LTEOP	SOLID YELLOW 4"
89	1463+62.94 TO 1464+51.75	NB LTEOP	SOLID YELLOW 4"
1142	1551+56.58 TO 1563+00.00	NB LTEOP	SOLID YELLOW 4"
3141	1547+59.32 TO 1579+00.00	SB LTEOP	SOLID YELLOW 4"
78	1552+83.56 TO 1553+59.49	SB LTEOP	SOLID YELLOW 4"
80	1541+85.85 TO 1542+67.26	NB LTEOP	SOLID YELLOW 4"
53	1512+00.01 TO 1512+51.68	NB LTEOP	SOLID YELLOW 4"
78	1474+63.71 TO 1475+37.98	NB LTEOP	SOLID YELLOW 4"
2982	1454+00.00 TO 1483+79.84	SB LTEOP	SOLID YELLOW 4"
6380	1483+79.09 TO 1547+59.32	SB LTEOP	SOLID YELLOW 4"
988	1541+66.52 TO 1551+55.82	NB LTEOP	SOLID YELLOW 4"
11065	1431+00.00 TO 1541+65.86	NB LTEOP	SOLID YELLOW 4"
737	1463+62.85 TO 1463+63.00	NB RTEOP	SOLID WHITE 8"
41	1462+49.12 TO 1464+11.78	SB RTEOP	WHITE SKIP-DASHED 8"
176	1464+22.97 TO 1465+97.73	SB RTEOP	SOLID WHITE 8"
126	1475+37.98 TO 1476+62.06	NB RTEOP	SOLID WHITE 8"
704	1477+76.99 TO 1477+77.97	SB RTEOP	SOLID WHITE 8"
50	1476+62.05 TO 1478+61.57	NB RTEOP	WHITE SKIP-DASHED 8"
34	1510+83.34 TO 1511+95.03	SB RTEOP	WHITE SKIP-DASHED 8"
409	1512+00.98 TO 1512+01.25	NB RTEOP	SOLID WHITE 8"
173	1511+95.03 TO 1513+68.99	SB RTEOP	SOLID WHITE 8"
153	1522+55.81 TO 1524+08.11	NB RTEOP	SOLID WHITE 8"
733	1524+33.12 TO 1524+34.12	SB RTEOP	SOLID WHITE 8"
32	1524+20.72 TO 1525+47.07	NB RTEOP	WHITE SKIP-DASHED 8"
50	1538+17.91 TO 1540+16.69	SB RTEOP	WHITE SKIP-DASHED 8"
799	1541+86.41 TO 1541+87.21	NB RTEOP	SOLID WHITE 8"
193	1540+16.69 TO 1542+07.13	SB RTEOP	SOLID WHITE 8"
671	1553+59.22 TO 1553+59.49	SB RTEOP	SOLID WHITE 8"
197	1552+22.95 TO 1554+21.86	NB RTEOP	SOLID WHITE 8"
35	1554+21.86 TO 1555+61.56	NB RTEOP	WHITE SKIP-DASHED 8"
23,743 TOTAL			

X0325110 BIAXIAL GEOGRID

SQ YD	LOCATION	SHEET	REMARKS
0	1451+00.00 TO 1457+00.00	SHEET 1	
0	1457+00.00 TO 1463+00.00	SHEET 2	
0	1463+00.00 TO 1469+00.00	SHEET 3	
0	1469+00.00 TO 1475+00.00	SHEET 4	
0	1475+00.00 TO 1481+00.00	SHEET 5	
215	1481+00.00 TO 1487+00.00	SHEET 6	
474	1487+00.00 TO 1493+00.00	SHEET 7	
439	1493+00.00 TO 1499+00.00	SHEET 8	
355	1499+00.00 TO 1504+00.00	SHEET 9	
363	1504+00.00 TO 1510+00.00	SHEET 10	
357	1510+00.00 TO 1515+00.00	SHEET 11	
385	1515+00.00 TO 1521+00.00	SHEET 12	
474	1521+00.00 TO 1527+00.00	SHEET 13	
508	1527+00.00 TO 1533+00.00	SHEET 14	
485	1533+00.00 TO 1539+00.00	SHEET 15	
469	1539+00.00 TO 1545+00.00	SHEET 16	
394	1545+00.00 TO 1551+00.00	SHEET 17	
455	1551+00.00 TO 1557+00.00	SHEET 18	
341	1557+00.00 TO 1561+63.55	SHEET 19	
5,714 TOTAL			

X2503000 MAINTENANCE MOWING

ACRE	LOCATION	OFFSET	DIRECTION	REMARKS
6.8	IL-92	RT	NB	20 FT FROM SHOULDER
6.8	IL-92	LT	SB	20 FT FROM SHOULDER
1.9	IL-92		MEDIAN	15 FT ALONG PAVEMENT
15.5 TOTAL				
62.0 TOTAL ASSUME 4 MAINTENANCE MOWING				

X6370150 CONCRETE BARRIER, VARIABLE CROSS-SECTION, 32" HEIGHT

FOOT	LOCATION	OFFSET	SHEET	REMARKS
10	1505+52.55 TO 1505+64.11			SOUTH OF RR
10	1508+52.94 TO 1508+64.88			NORTH OF RR
10	1516+78.33 TO 1516+88.51			SOUTH OF 18TH
10	1518+66.20 TO 1518+76.35			NORTH OF 18TH
10	1546+23.16 TO 1546+33.21			SOUTH OF 7TH
10	1548+11.90 TO 1548+21.95			NORTH OF 7TH
60 TOTAL				

X7050167 TEMPORARY TRAFFIC BARRIER TERMINAL, TYPE 1, SPECIAL (TANGENT)

EACH	LOCATION	OFFSET	DIRECTION	REMARKS
1	1474+01	LT EOS	SB	STAGE 1
1	1467+77	RT EOS	NB	STAGE 2
2 TOTAL				

X0301766 DRILL AND GROUT #6 TIE BAR

EACH	LOCATION	OFFSET	DIRECTION	REMARKS
11	RR BRIDGE		SB	SOUTH OF RR
10	RR BRIDGE		NB	SOUTH OF RR
12	RR BRIDGE		NB	NORTH OF RR
14	RR BRIDGE		SB	NORTH OF RR
47 TOTAL				

REVISIONS		ILLINOIS DEPARTMENT OF TRANSPORTATION
NAME	DATE	
		SCALE: NONE DATE: _____ DRAWN BY: JW CHECKED BY: MGZ

PLOT DATE : #DPTES
FILE NAME : #FILELS
CITY : #CITYL
USER : #USER

SCHEDULE OF QUANTITIES

F.A.P. RTE.	SECTION	COUNTY	TOTAL SHEETS	SHEET NO.
308	108B,108-1,108,108-2R	ROCK ISLAND	210	228
STA.		TO STA.		
FED. ROAD DIST. NO. 2		ILLINOIS FED. AID PROJECT		

DRAINAGE STRUCTURE TYPE 1 SPECIAL

EACH	LOCATION	OFFSET	DIRECTION	REMARKS
1	1487+58.80			
1	1499+05.60			
1	1500+50.00			
1	1501+83.40			
1	1511+46.90			
1	1513+00.00			
1	1514+17.50			
1	1515+10.00			
1	1515+71.30			
1	1519+50.00			
1	1520+10.60			
1	1541+00.00			
1	1542+55.30			
1	1544+00.00			
1	1550+75.00			
1	1552+26.00			
1	1553+20.00			
1	1553+72.00			
1	1556+53.50			
1	1559+56.60			
1	1560+75.00			
<hr/>				
21	TOTAL			

DRAINAGE STRUCTURE TYPE 2 SPECIAL

EACH	LOCATION	OFFSET	DIRECTION	REMARKS
1	1486+58.50			
1	1514+94.10			
1	1540+57.30			
1	1540+75.00			
1	1552+99.00			
<hr/>				
5	TOTAL			

TEMPORARY TRAFFIC BARRIER TERMINAL, TYPE 6A

EACH	LOCATION	OFFSET	DIRECTION	REMARKS
1	1471+33	LT EOS	SB	STAGE 1
1	1470+12	RT EOS	NB	STAGE 2
<hr/>				
2	TOTAL			

PLOT DATE * #DATE*
 FILE NAME * #FILE*
 PLOT SCALE * #SCALE*
 USER NAME * #USER*

REVISIONS		ILLINOIS DEPARTMENT OF TRANSPORTATION	
NAME	DATE		
SCALE: NONE		DRAWN BY	JW
DATE		CHECKED BY	MGZ

F.A.P. RTE.	SECTION	COUNTY	TOTAL SHEETS	SHEET NO.
308	1 (H&H-1, V&H-2) R	ROCK ISLAND	210	24
STA. 1450+00.00		TO STA. 1570+00.00		
FED. ROAD DIST. NO. 2		ILLINOIS FED. AID PROJECT		

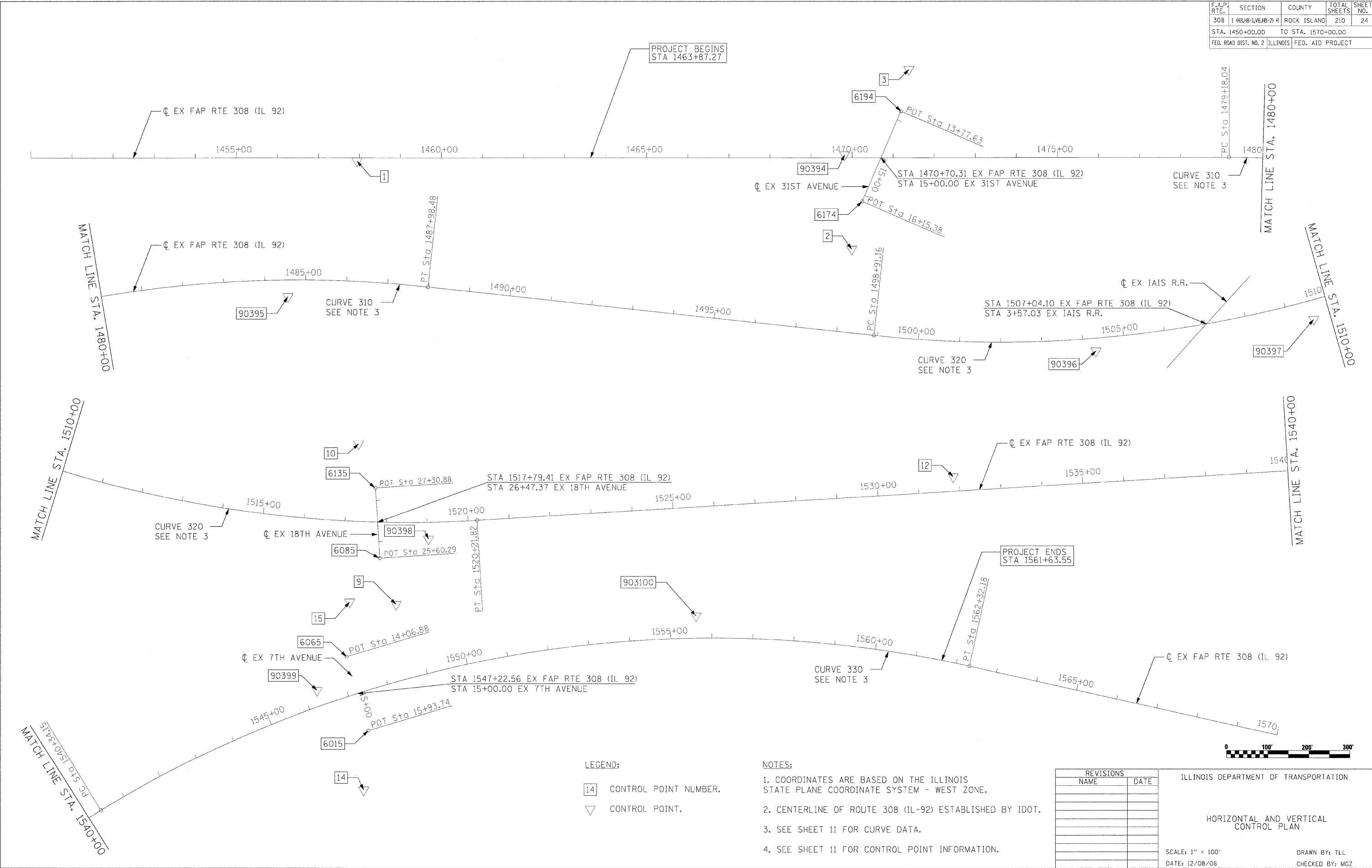

PROJECT BEGINS
STA 1463+87.27

PROJECT ENDS
STA 1561+63.55

- LEGEND:
- 14 CONTROL POINT NUMBER.
 - ▽ CONTROL POINT.

- NOTES:
1. COORDINATES ARE BASED ON THE ILLINOIS STATE PLANE COORDINATE SYSTEM - WEST ZONE.
 2. CENTERLINE OF ROUTE 308 (IL-92) ESTABLISHED BY IDOT.
 3. SEE SHEET 11 FOR CURVE DATA.
 4. SEE SHEET 11 FOR CONTROL POINT INFORMATION.

REVISIONS	
NAME	DATE

ILLINOIS DEPARTMENT OF TRANSPORTATION

HORIZONTAL AND VERTICAL CONTROL PLAN

SCALE: 1" = 100'
DATE: 12/08/06

DRAWN BY: TLL
CHECKED BY: MGZ

PLOT DATE = #DATE#
FILE NAME = #FILE#
PLOT SCALE = #SCALE#
USER NAME = #USER#

IL 92 HORIZONTAL AND VERTICAL CONTROL - STA 1450+00 TO 1570+00

F.A.P. RTE.	SECTION	COUNTY	TOTAL SHEETS	SHEET NO.
308	1 (H&H-1,VB,H&H-2) R	ROCK ISLAND	210	25
STA. 1450+63.70		TO STA. 1457+00.00		
FED. ROAD DIST. NO. 2		ILLINOIS	FED. AID PROJECT	

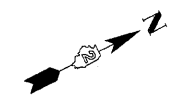

PLAN	DATE	BY
SURVEYED		
ALIGNED		
NOTED		
CHECKED		
NO.		
FILE NAME		

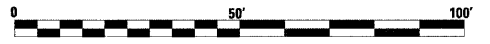
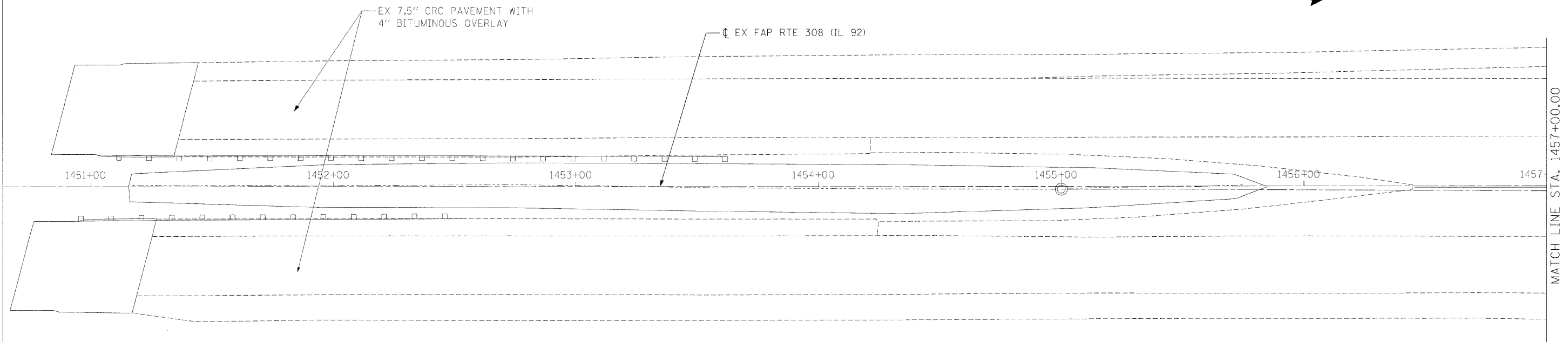

PROFILE	DATE	BY
SURVEYED		
ALIGNED		
NOTED		
CHECKED		
NO.		
FILE NAME		

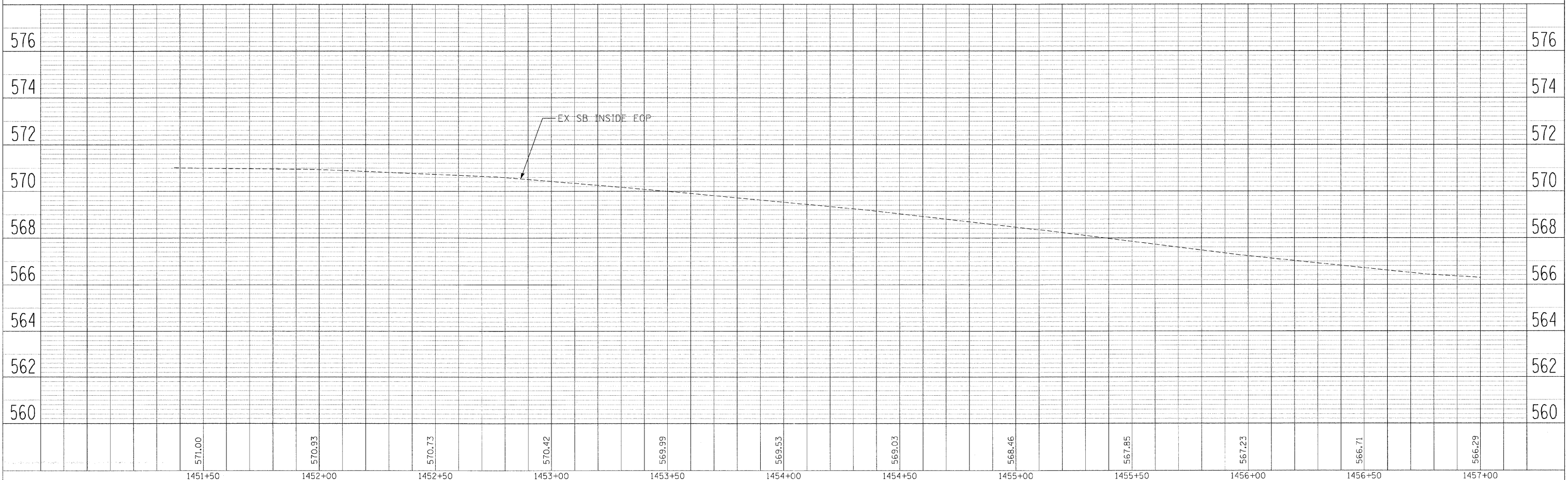

PLOT DATE = #DATE#
 FILE NAME = #FILE#
 PLOT SCALE = #SCALE#
 USER NAME = #USER#

F.A.P. RTE.	SECTION	COUNTY	TOTAL SHEETS	SHEET NO.
308	1 (H&H-1, V&H-2) R	ROCK ISLAND	210	26
STA. 1457+00.00		TO STA. 1463+00.00		
FED. ROAD DIST. NO. 2		ILLINOIS FED. AID PROJECT		

PLAN	SURVEYED	BY	DATE
NOTE BOOK NO.	ALIGNMENT CHECKED		
	RT. OF WAY CHECKED		
	JOB FILE NAME		

PROFILE	SURVEYED	BY	DATE
NOTE BOOK NO.	GRADES CHECKED		
	S.M. NOTED		
	STRUCTURE NOTATIONS CHECKED		

PLOT DATE = #DATE#
 FILE NAME = #FILE#
 PLOT SCALE = #SCALE#
 USER NAME = #USER#

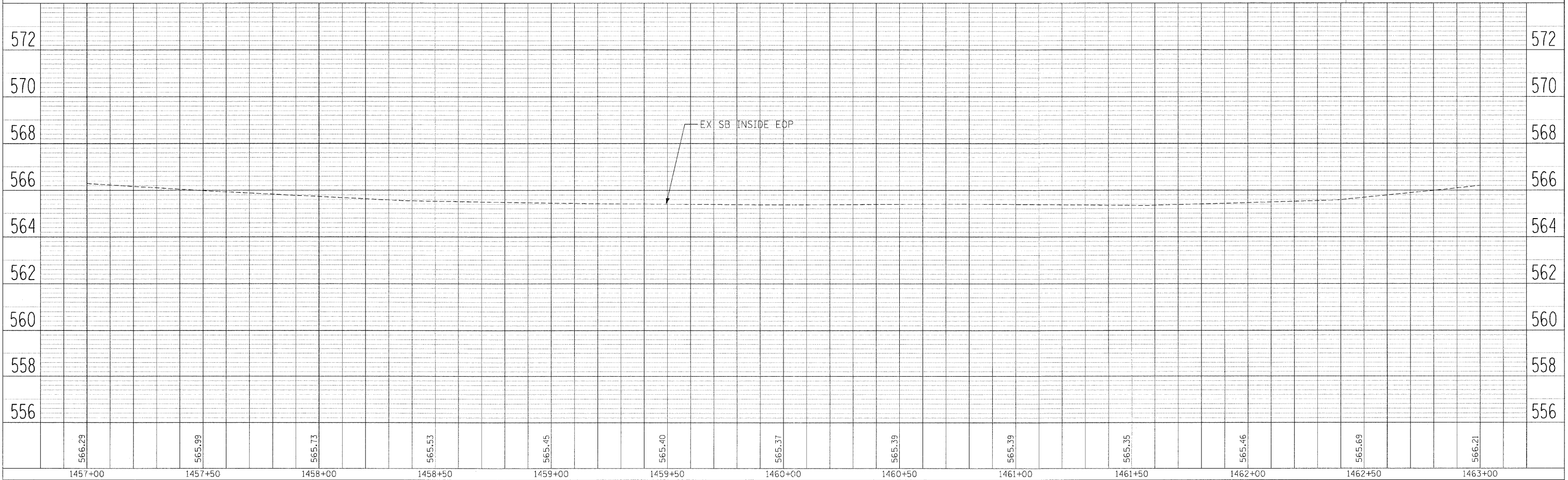
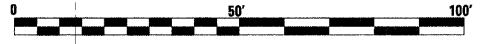
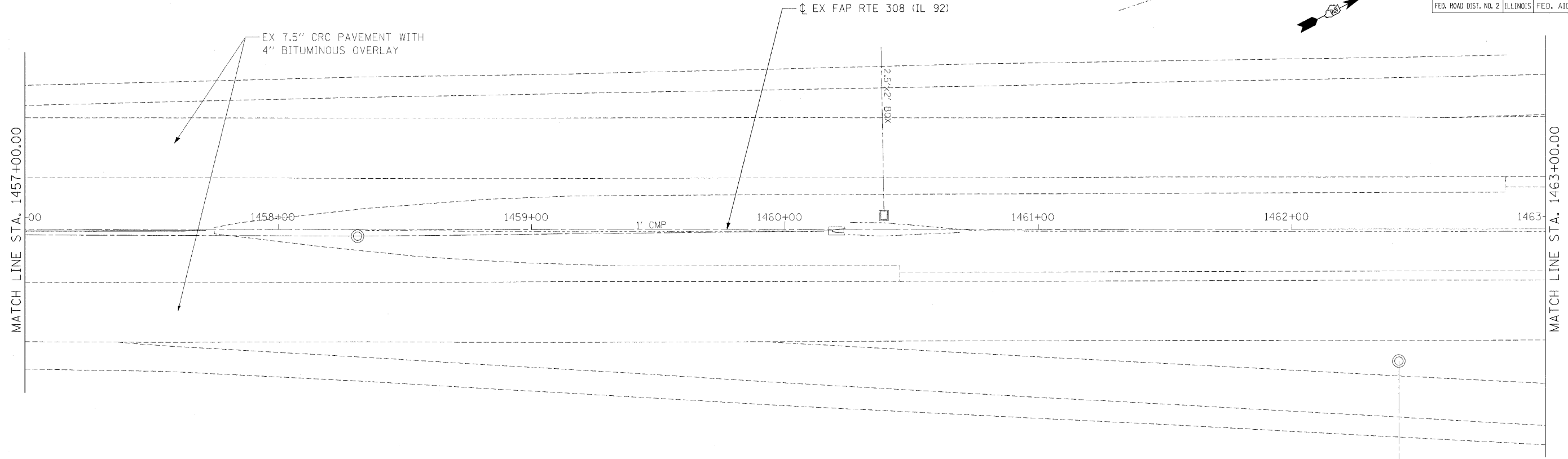

F.A.P. RTE.	SECTION	COUNTY	TOTAL SHEETS	SHEET NO.
308	1 (H)B-1, (H)B-2 R	ROCK ISLAND	210	27
STA. 1463+00.00		TO STA. 1469+00.00		
FED. ROAD DIST. NO. 2		ILLINOIS		FED. AID PROJECT

PLAN	SURVEYED	BY	DATE
NOTE BOOK NO.	ALIGNED		
	BT. OF WAY CHECKED		
	PAID FILE NAME		

PROFILE	SURVEYED	BY	DATE
NOTE BOOK NO.	GRADES CHECKED		
	IN AL. NOTED		
	STRUCTURE NOTATIONS DPTD		

PLOT DATE = *DATE*
 FILE NAME = *FILE*
 PLOT SCALE = *SCALE*
 USER NAME = *USER*

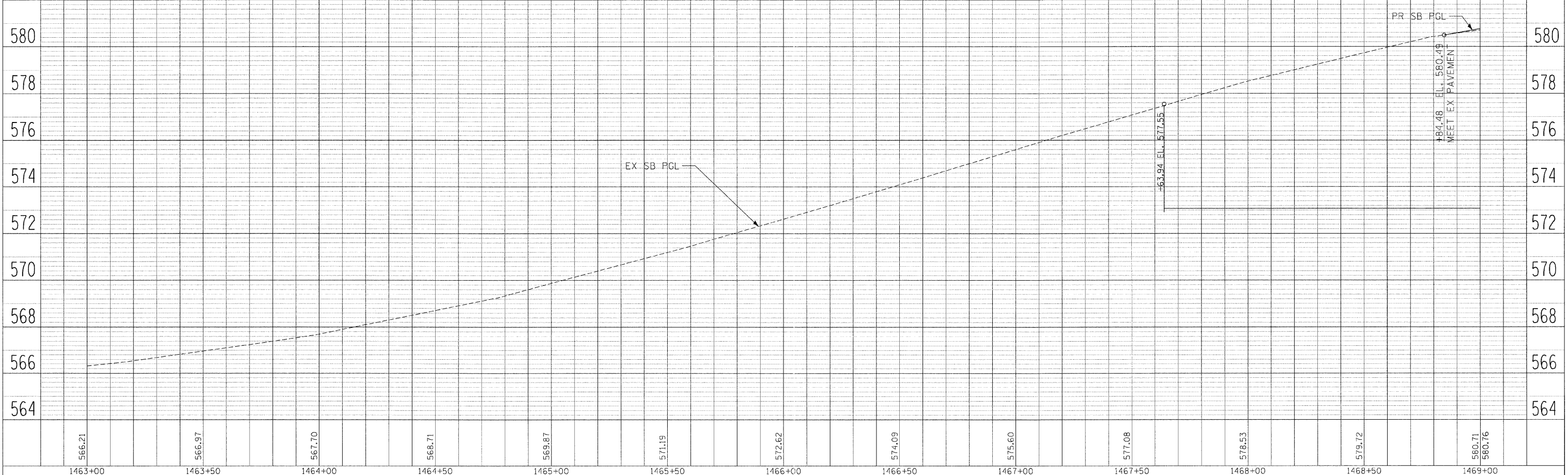
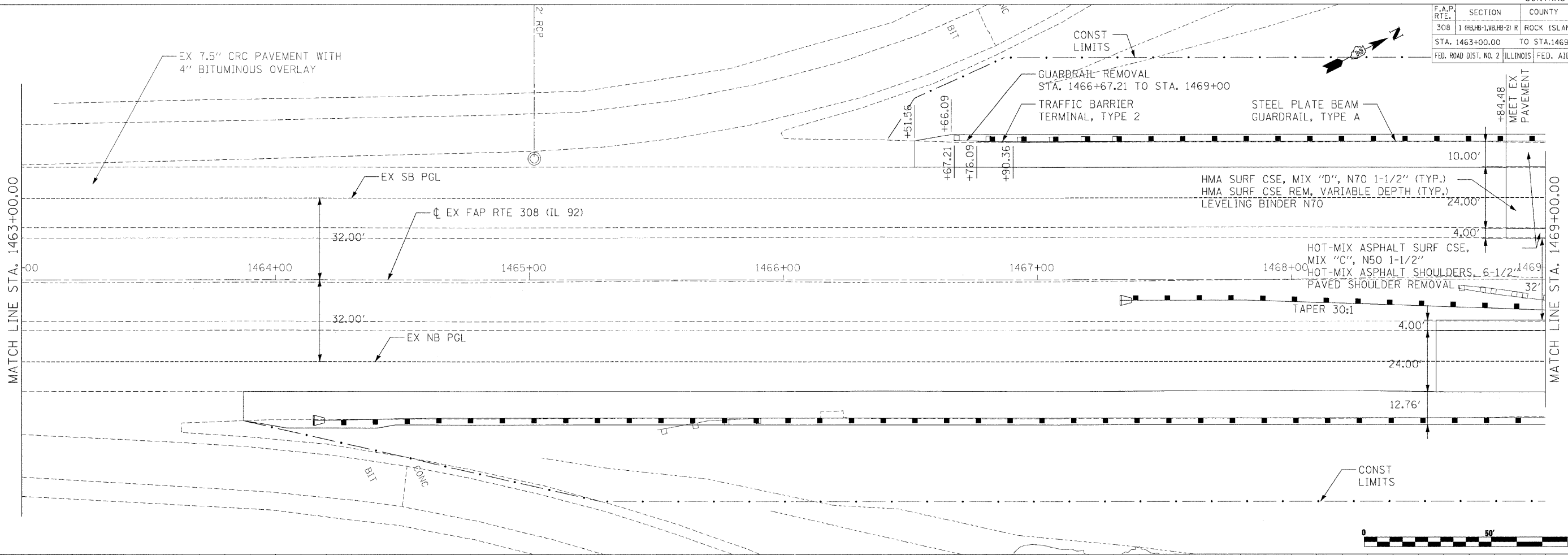

SOUTHBOUND IL RTE 92 PLAN & PROFILE - STA 1463+00 TO STA 1469+00

F.A.P. RTE.	SECTION	COUNTY	TOTAL SHEETS	SHEET NO.
308	1 (WB)B-1(WB)B-2) R	ROCK ISLAND	210	28
STA. 1463+00.00		TO STA. 1469+00.00		
FED. ROAD DIST. NO. 2		ILLINOIS		FED. AID PROJECT

PLAN	DATE	BY
SURVEYED		
ALIGNED		
CHECKED		
BY		
NO. OF WAY CHECKED		
PAID FILE NAME		
NO.		

PROFILE	DATE	BY
SURVEYED		
GRADES CHECKED		
BY		
NOTED		
STRUCTURE NOTATIONS CHECKED		
NO.		

PLOT DATE = 8/24/15
 FILE NAME = 8/24/15
 PLOT SCALE = 1"=40'
 USER NAME = BLSBNS

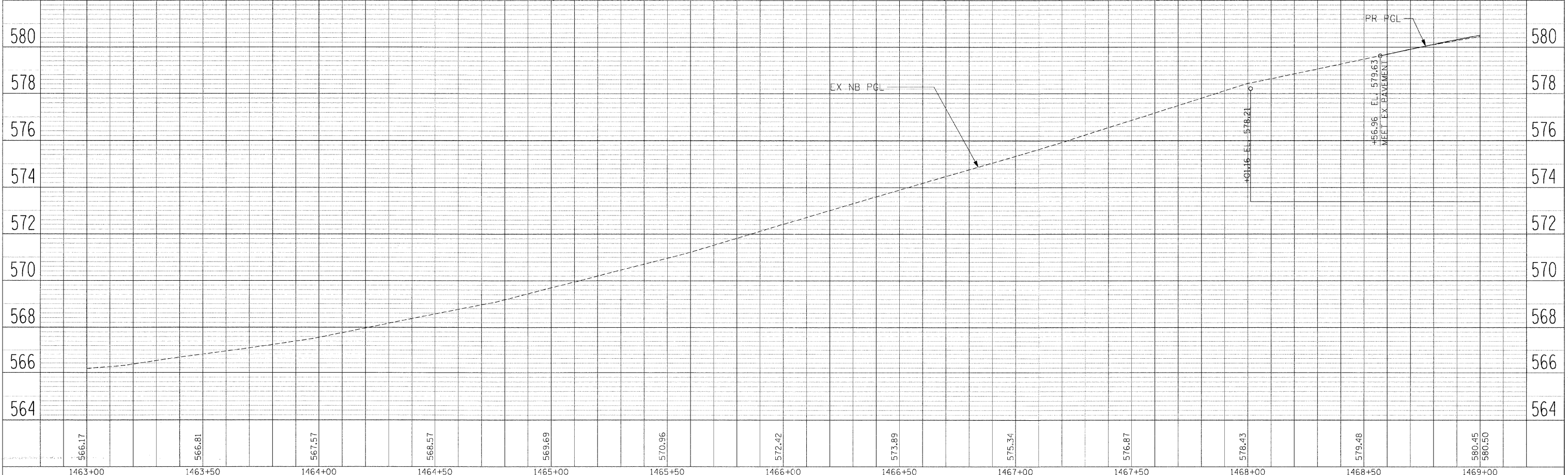
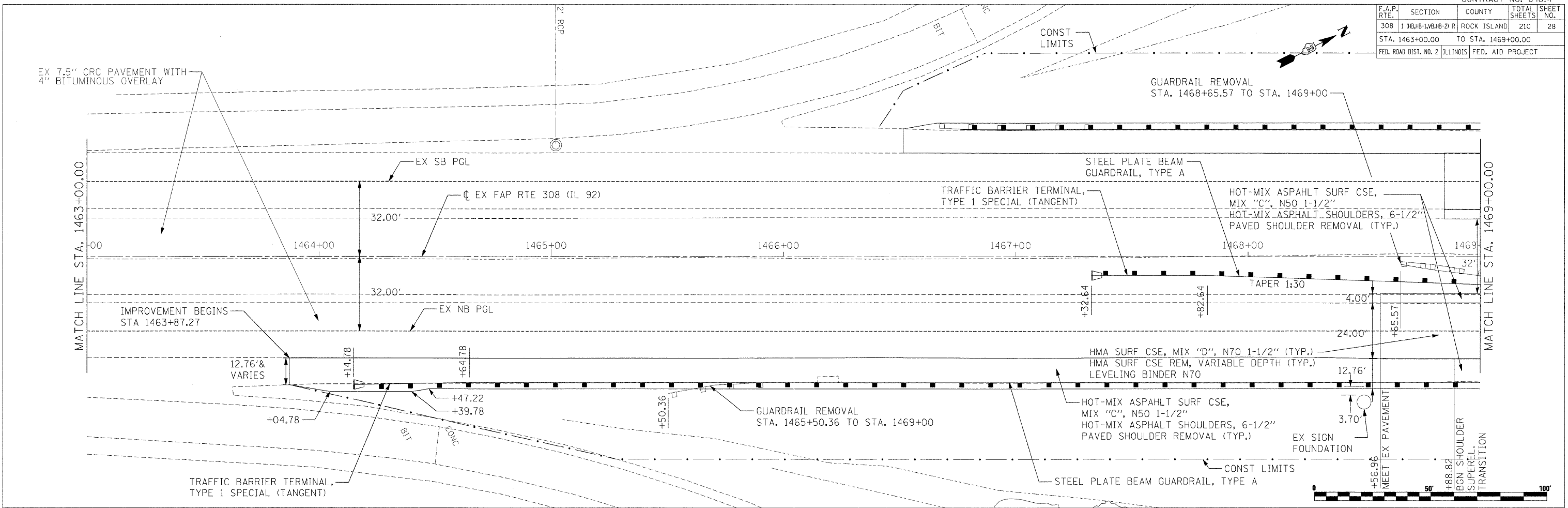

NORTHBOUND IL RTE 92 PLAN & PROFILE STA 1463+00 TO STA 1469+00

F.A.P. RTE.	SECTION	COUNTY	TOTAL SHEETS	SHEET NO.
308	1 (WB) HB-LWB-HB-2 R	ROCK ISLAND	210	29
STA. 1469+00.00 TO STA. 1475+00.00		FED. ROAD DIST. NO. 2 ILLINOIS FED. AID PROJECT		

PLAN	DATE	BY
SURVEYED		
NOTED		
CHECKED		
DATE		

PROFILE	DATE	BY
SURVEYED		
NOTED		
CHECKED		
DATE		

PLOT DATE = #DATE#
 FILE NAME = #FILE#
 USER = #USER#

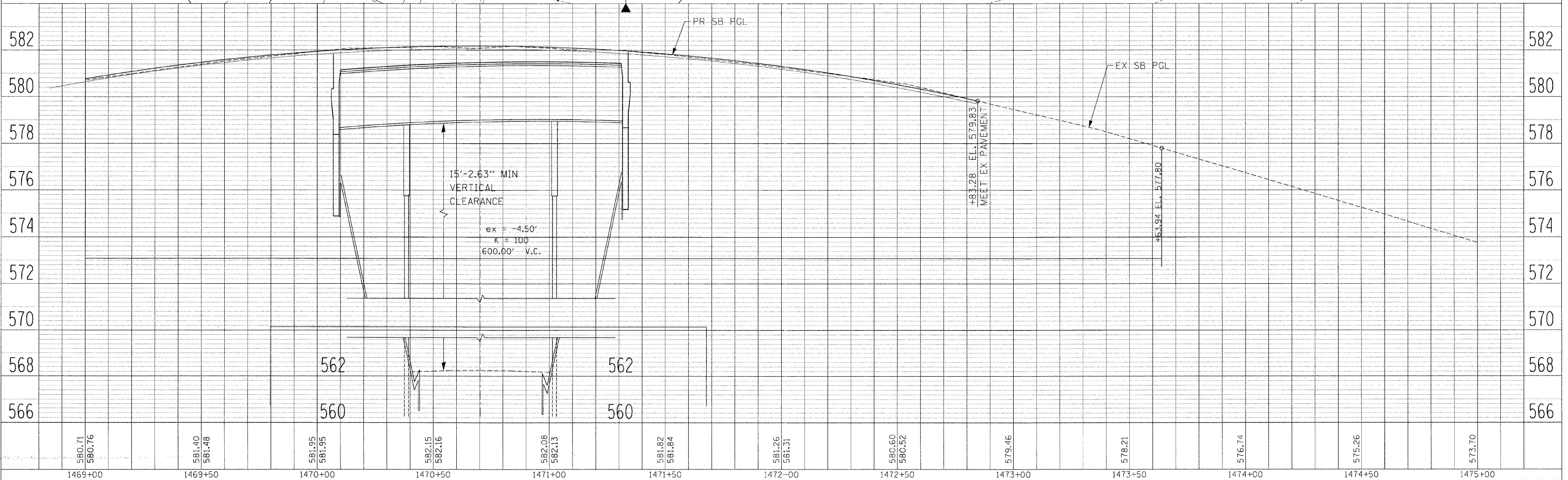
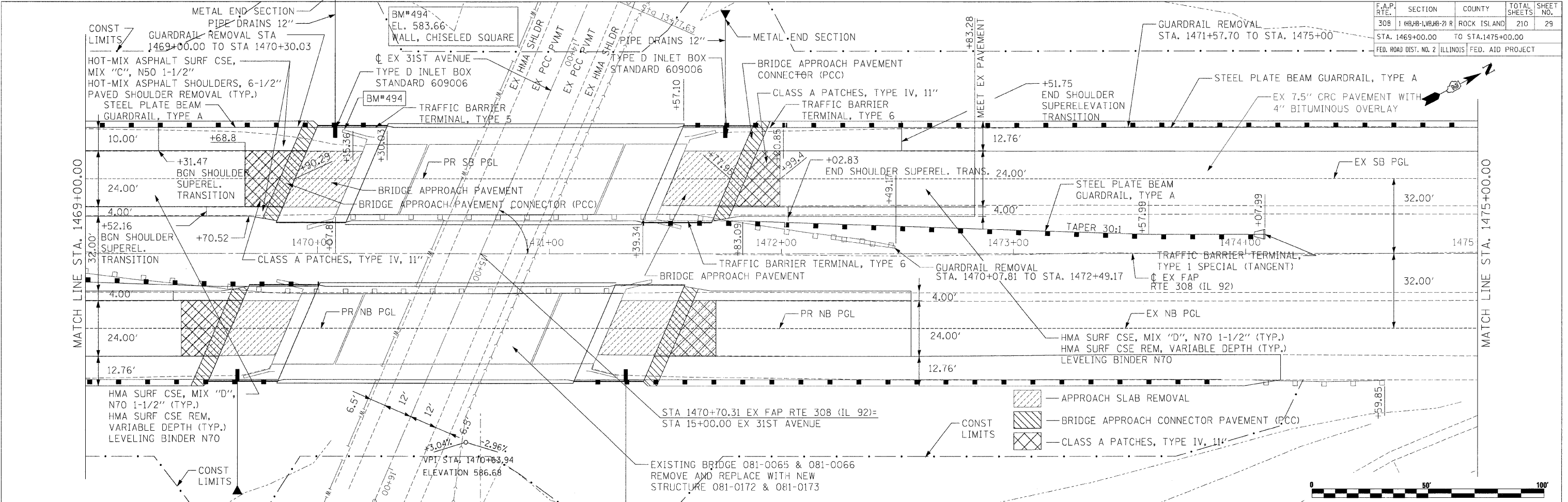

SOUTHBOUND IL RTE 92 PLAN & PROFILE - STA 1469+00 TO 1475+00

F.A.P. RTE.	SECTION	COUNTY	TOTAL SHEETS	SHEET NO.
308	I 08A/B-1,6/18-2/ R	ROCK ISLAND	210	30
STA. 1469+00.00 TO STA. 1475+00.00		FED. ROAD DIST. NO. 2 ILLINOIS FED. AID PROJECT		

CONTRACT NO. 64814

DATE: _____
 BY: _____
 SURVEYED: _____
 ALTIMETER CHECKED: _____
 GRADES CHECKED: _____
 NO. _____
 PLAN: _____
 NOTE BOOK NO. _____
 DATE: _____

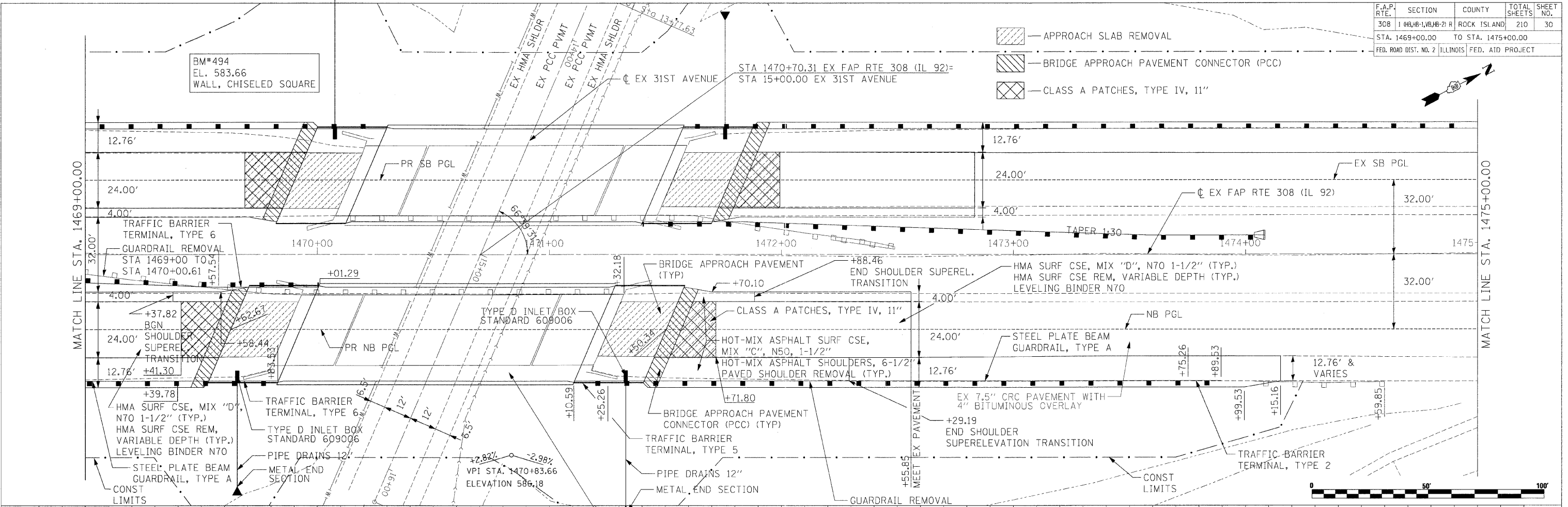

DATE: _____
 BY: _____
 SURVEYED: _____
 GRADES CHECKED: _____
 NO. _____
 PROFILE: _____
 NOTE BOOK NO. _____
 DATE: _____

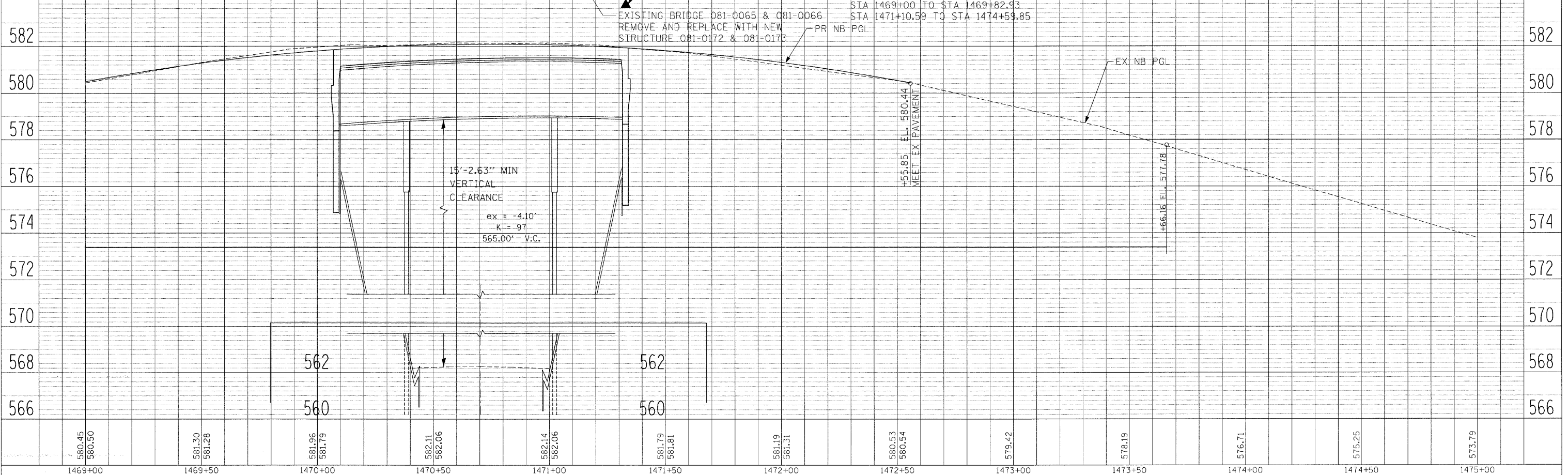

NORTHBOUND IL RTE 92 PLAN & PROFILE - STA 1469+00 TO 1475+00

PLOT DATE = 8/4/15
 FILE NAME = 8/15/15
 USER NAME = P0000000

F.A.P. RTE.	SECTION	COUNTY	TOTAL SHEETS	SHEET NO.
308	1 (WB, WB-1, WB, WB-2) R	ROCK ISLAND	210	31
STA. 1475+00.00		TO STA. 1481+00.00		
FED. ROAD DIST. NO. 2		ILLINOIS		
		FED. AID PROJECT		

PLAN	DATE	BY
SURVEYED		
ALIGNED		
CHECKED		
RT. OF WAY CHECKED		
NOTE BOOK NO.		
FILE NAME		

PROFILE	DATE	BY
SURVEYED		
GRADES CHECKED		
B.M. NOTED		
STRUCTURE NOTATIONS CHECKED		
NOTE BOOK NO.		
FILE NAME		

PLOT DATE = #DATE#
 FILE NAME = #FILE#
 PLOT SCALE = #SCALE#
 USER NAME = #USER#

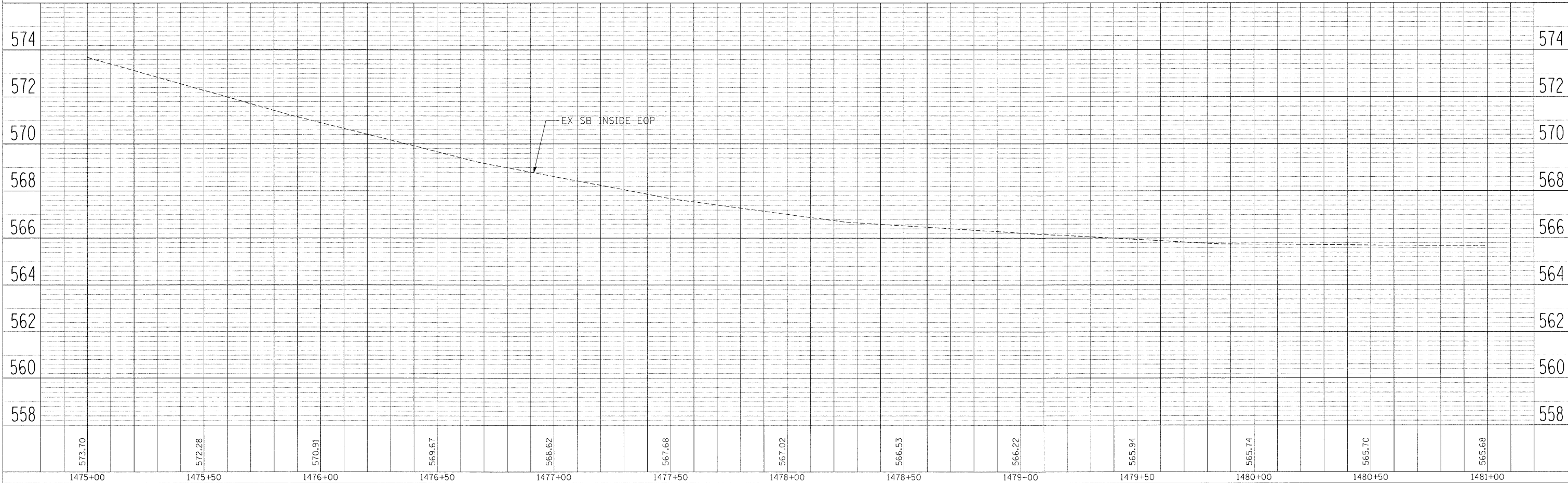
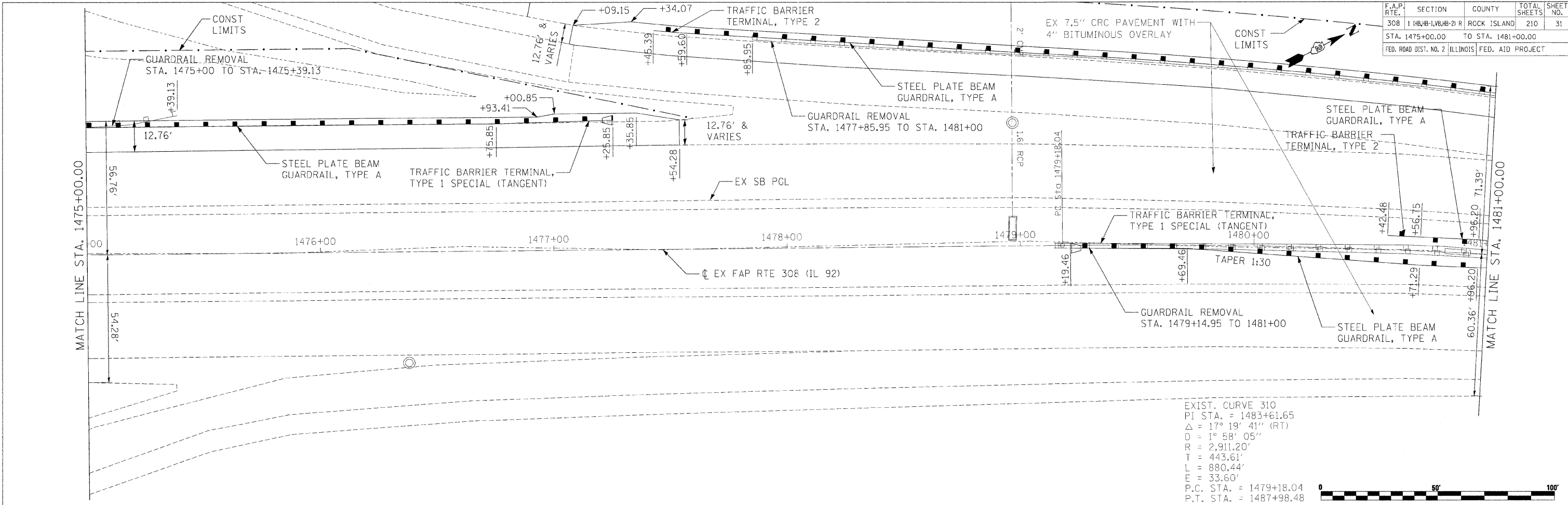

IL RTE 92 PLAN & PROFILE - STA 1475+00 TO STA 1481+00

F.A.P. RTE.	SECTION	COUNTY	TOTAL SHEETS	SHEET NO.
308	1 (WB, WB-1, WB, WB-2) R	ROCK ISLAND	210	32

STA. 1481+00.00 TO STA. 1487+00.00

FED. ROAD DIST. NO. 2 ILLINOIS FED. AID PROJECT

CULVERT TO BE CLEANED GRADING AND SHAPING DITCHES

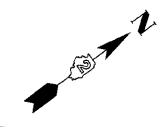

PLAN	DATE
SURVEYED	
ALIGNED	
CHECKED	
BY	
NOTE BOOK NO.	
FILE NAME	

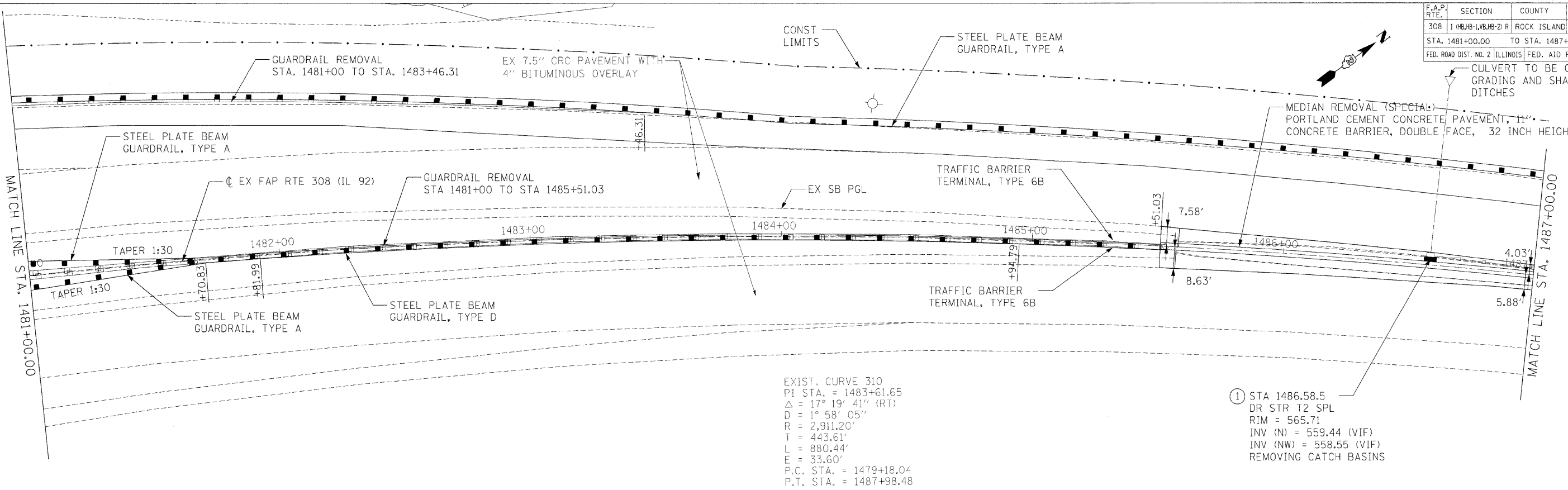

EXIST. CURVE 310
 PI STA. = 1483+61.65
 $\Delta = 17^\circ 19' 41''$ (RT)
 $D = 1^\circ 58' 05''$
 $R = 2,911.20'$
 $T = 443.61'$
 $L = 880.44'$
 $E = 33.60'$
 P.C. STA. = 1479+18.04
 P.T. STA. = 1487+98.48

① STA 1486.58.5
 DR STR T2 SPL
 RIM = 565.71
 INV (N) = 559.44 (VIF)
 INV (NW) = 558.55 (VIF)
 REMOVING CATCH BASINS

VIF: VERIFY IN FIELD

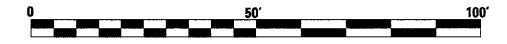

PROFILE	DATE
SURVEYED	
ROADS	
CHECKED	
BY	
NOTE BOOK NO.	
FILE NAME	

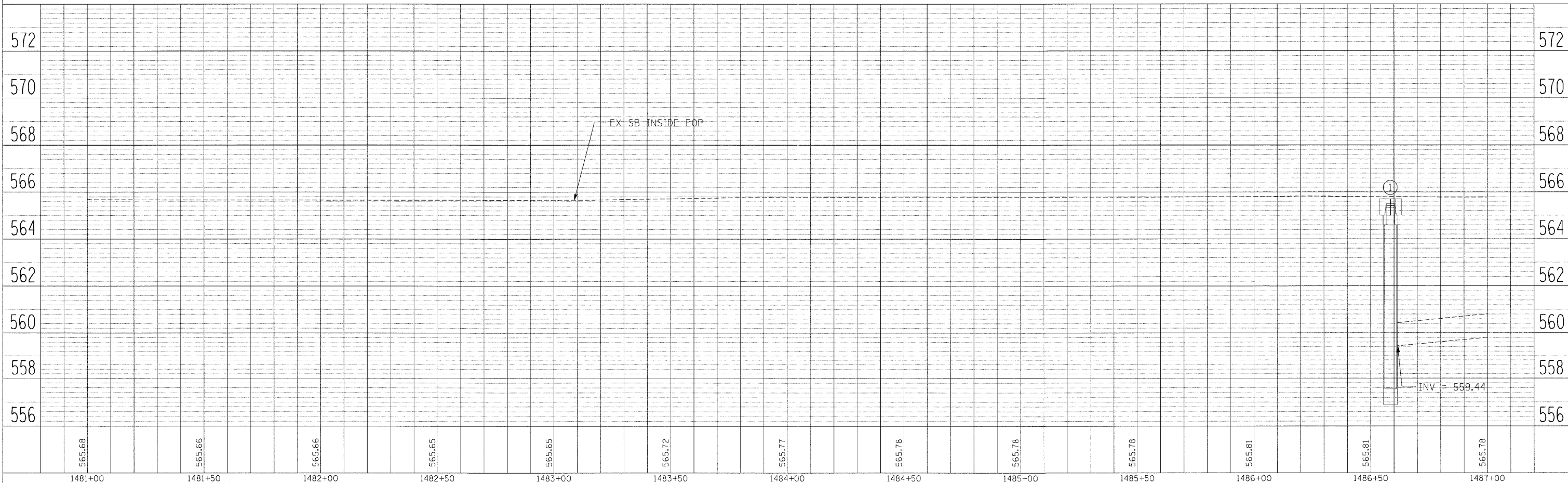

PLOT DATE = #DATE#
 FILE NAME = #FILE#
 PLOT SCALE = #SCALE#
 USER NAME = #USER#

F.A.P. RTE.	SECTION	COUNTY	TOTAL SHEETS	SHEET NO.
308	1 (WB, WB-1, WB, WB-2) R	ROCK ISLAND	210	33
STA. 1487+00.00 TO STA. 1493+00.00				
FED. ROAD DIST. NO. 2 ILLINOIS FED. AID PROJECT				

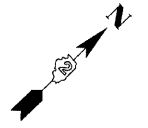

PLAN	DATE	BY
SURVEYED		
NOTE BOOK		
NO.		

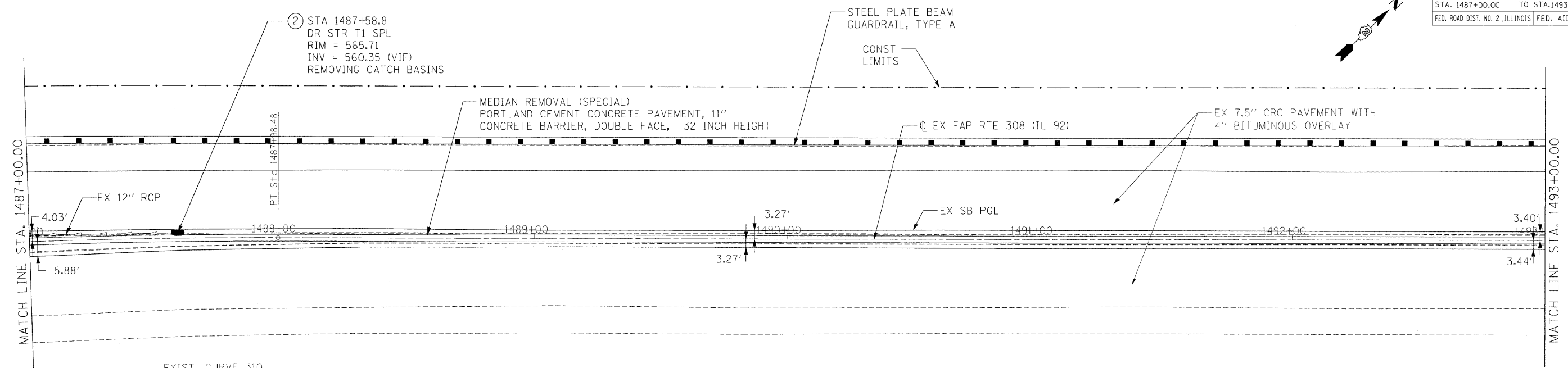

EXIST. CURVE 310
 PI STA. = 1483+61.65
 $\Delta = 17^\circ 19' 41''$ (RT)
 $D = 1^\circ 58' 05''$
 $R = 2,911.20'$
 $T = 443.61'$
 $L = 880.44'$
 $E = 33.60'$
 P.C. STA. = 1479+18.04
 P.T. STA. = 1487+98.48

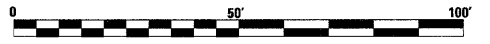

PROFILE	DATE	BY
SURVEYED		
NOTE BOOK		
NO.		

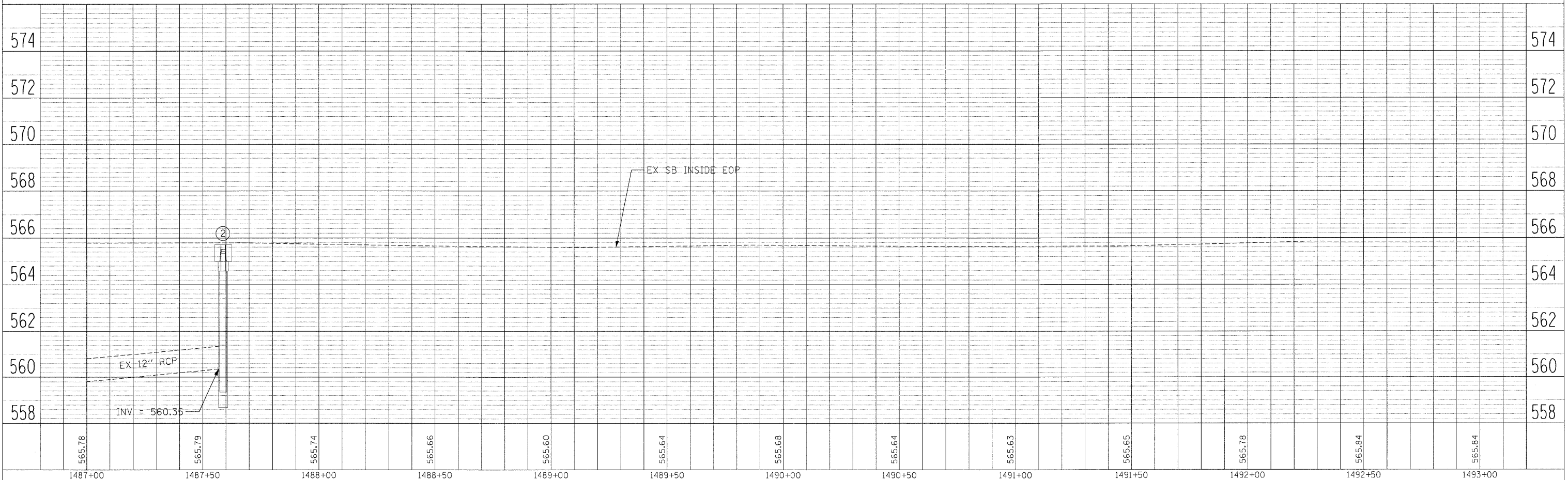

PLOT DATE = #DATE#
 FILE NAME = #FILE#
 PLOT SCALE = #SCALE#
 USER NAME = #USER#

F.A.P. RTE.	SECTION	COUNTY	TOTAL SHEETS	SHEET NO.
308	1 (WB, HB, LB, RB-2) R	ROCK ISLAND	210	34
STA. 1493+00.00		TO STA. 1499+00.00		
FED. ROAD DIST. NO. 2		ILLINOIS FED. AID PROJECT		

PLAN	SURVEYED	BY	DATE
FILE NAME	FILE NO.		
NOTE BOOK NO.	RT. OF WAY CHECKED		
	END FILE NAME		

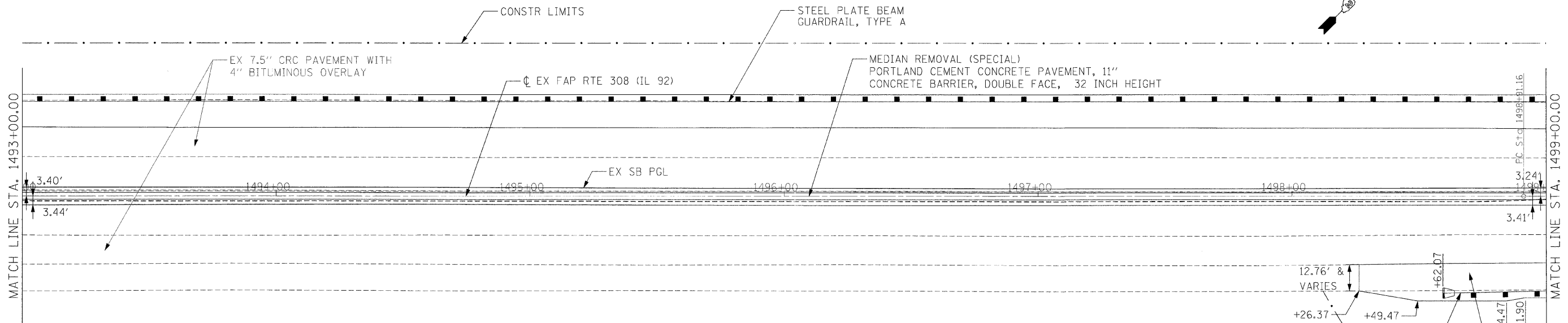

EXIST. CURVE 320
 PI STA. = 1510+08.65
 $\Delta = 42^\circ 40' 47''$ (LT)
 $D = 2^\circ 00' 11''$
 $R = 2,860.32'$
 $T = 1,117.49'$
 $L = 2,130.66'$
 $E = 210.54'$
 P.C. STA. = 1498+91.16
 P.T. STA. = 1520+21.82

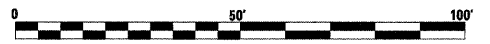
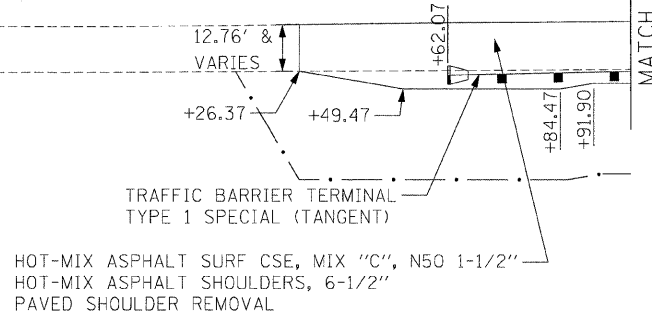

PROFILE	SURVEYED	BY	DATE
FILE NAME	FILE NO.		
NOTE BOOK NO.	RT. OF WAY CHECKED		
	END FILE NAME		

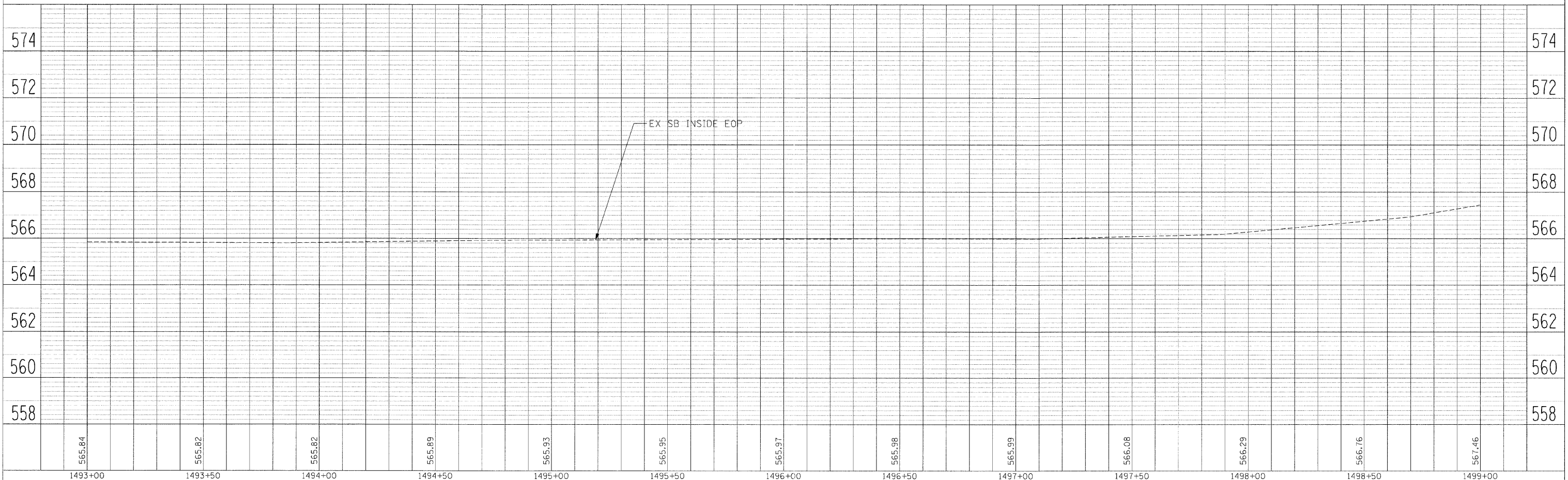

F.A.P. RTE.	SECTION	COUNTY	TOTAL SHEETS	SHEET NO.
308	1 (H&H-1,VB,H&B-2) R	ROCK ISLAND	210	35
STA. 1499+00.00 TO STA. 1504+00.00				
FED. ROAD DIST. NO. 2 ILLINOIS FED. AID PROJECT				

PLAN	SURVEYED	DATE
ALIGNED		
NOTED		
NOTE BOOK NO.		
FILE NAME		
FILE NO.		

PROFILE	SURVEYED	DATE
ALIGNED		
NOTED		
NOTE BOOK NO.		
FILE NAME		
FILE NO.		

PLOT DATE = #DATE#
 FILE NAME = #FILE#
 PLOT SCALE = #SCALE#
 USER NAME = #USER#

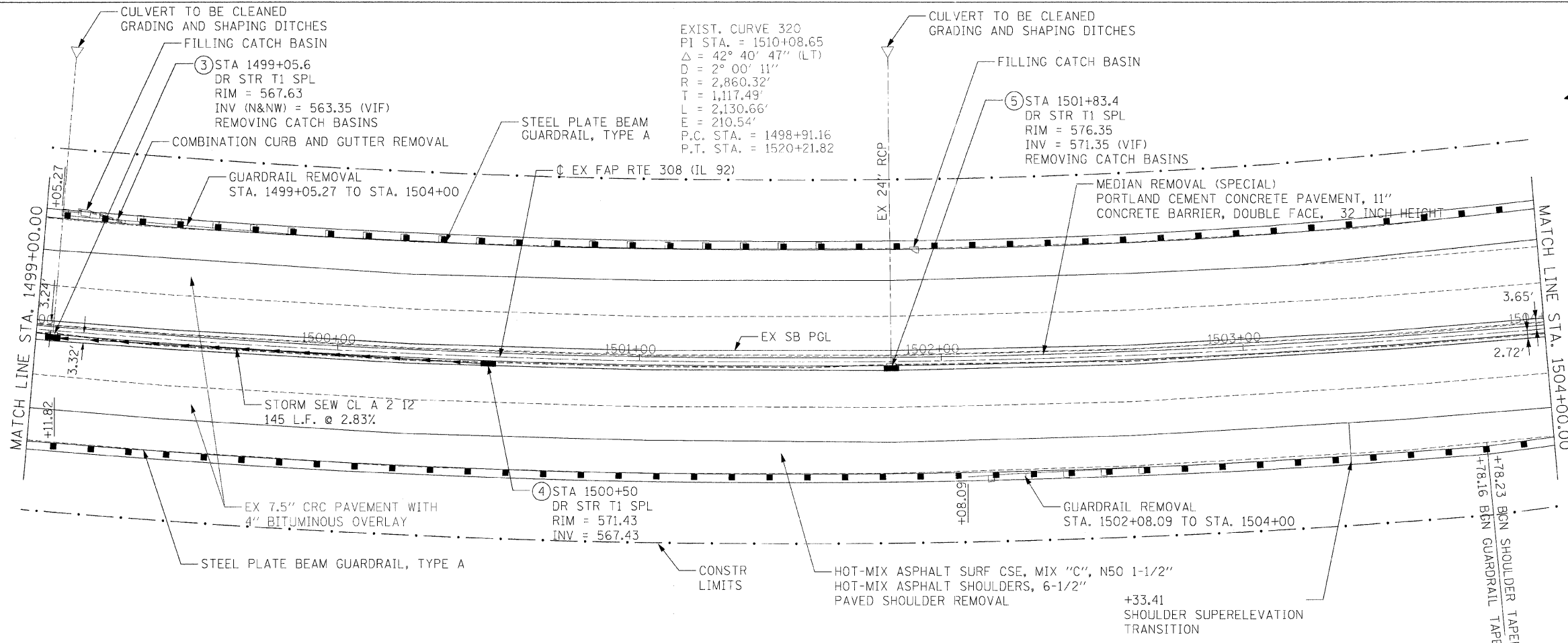

EXIST. CURVE 320
 P.I. STA. = 1510+08.65
 $\Delta = 42^\circ 40' 47''$ (LT)
 $D = 2^\circ 00' 11''$
 $R = 2,860.32'$
 $T = 1,117.49'$
 $L = 2,130.66'$
 $E = 210.54'$
 P.C. STA. = 1498+91.16
 P.T. STA. = 1520+21.82

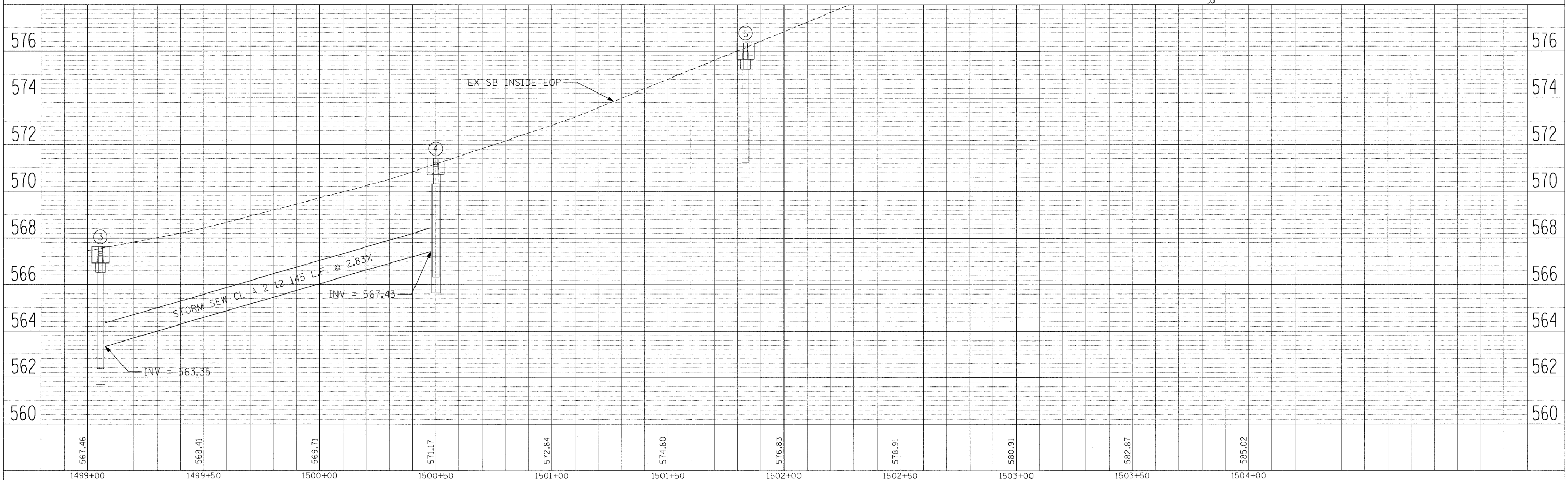
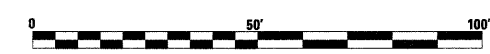

IL RTE 92 PLAN & PROFILE - STA 1499+00 TO STA 1504+00

F.A.P. RTE.	SECTION	COUNTY	TOTAL SHEETS	SHEET NO.
308	1 (H&H-1,VB,H&2) R	ROCK ISLAND	210	36
STA. 1504+00.00 TO STA. 1510+00.00				
FED. ROAD DIST. NO. 2 ILLINOIS FED. AID PROJECT				

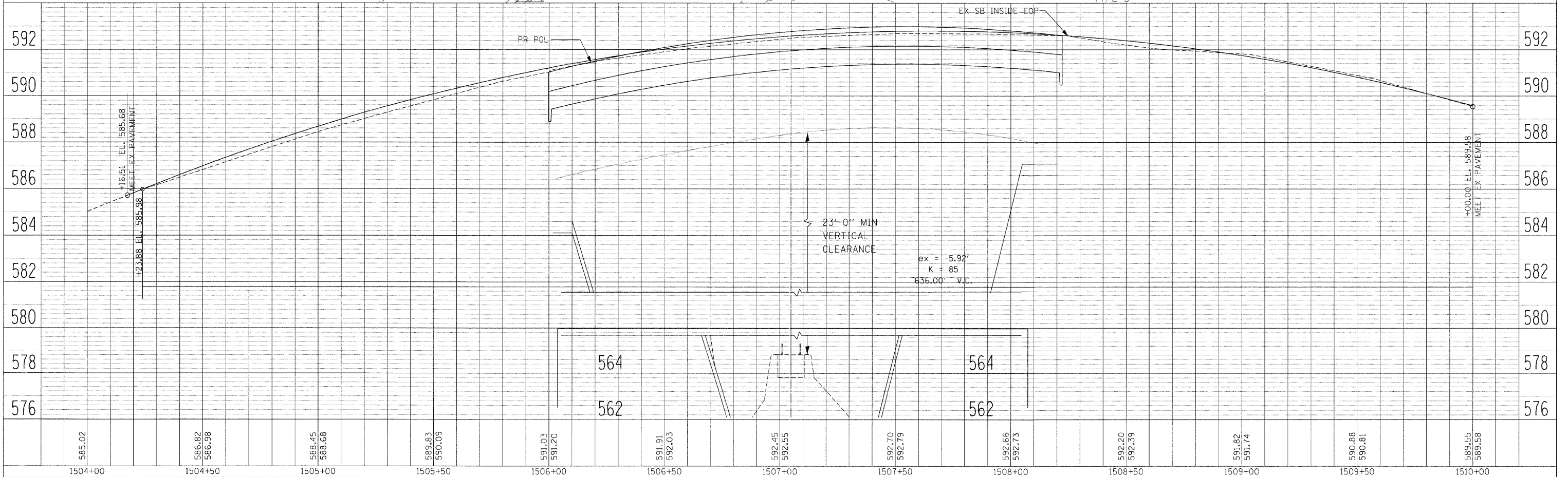
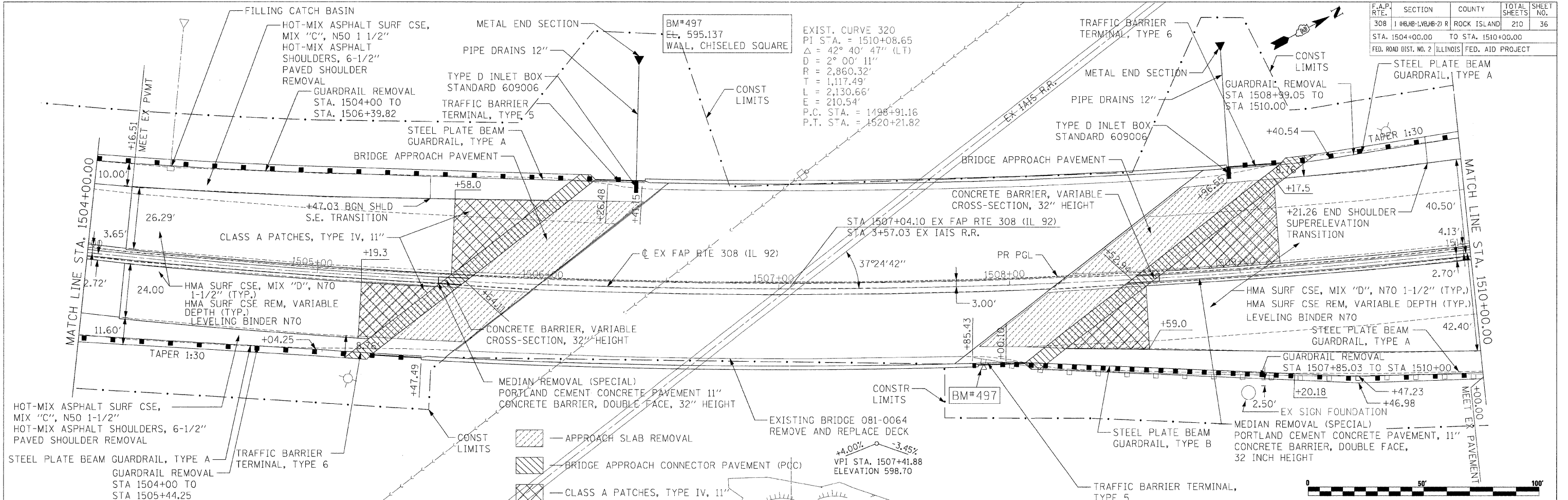

DATE	BY	REVISION

DATE	BY	REVISION

PLOT DATE = 04/15/15
 FILE NAME = #FILES#
 PLOT SCALE = #SCALE#
 USER NAME = #USER#

IL 92 PLAN & PROFILE - STA 1504+00 TO 1510+00

F.A.P. RTE.	SECTION	COUNTY	TOTAL SHEETS	SHEET NO.
308	1 (H&H-L&B-H&B-2) R	ROCK ISLAND	210	37
STA. 1510+00.00		TO STA. 1515+00.00		
FED. ROAD DIST. NO. 2		ILLINOIS		FED. AID PROJECT

EXIST. CURVE 320
 PI STA. = 1510+08.65
 $\Delta = 42^\circ 40' 47''$ (LT)
 $D = 2^\circ 00' 11''$
 $R = 2,860.32'$
 $T = 1,117.49'$
 $L = 2,130.66'$
 $E = 210.54'$
 P.C. STA. = 1498+91.16
 P.T. STA. = 1520+21.82

DATE	BY
DATE	BY
DATE	BY

DATE	BY
DATE	BY
DATE	BY

PLOT DATE = 8/20/15
 FILE NAME = 81515
 USER NAME = RUSSELL

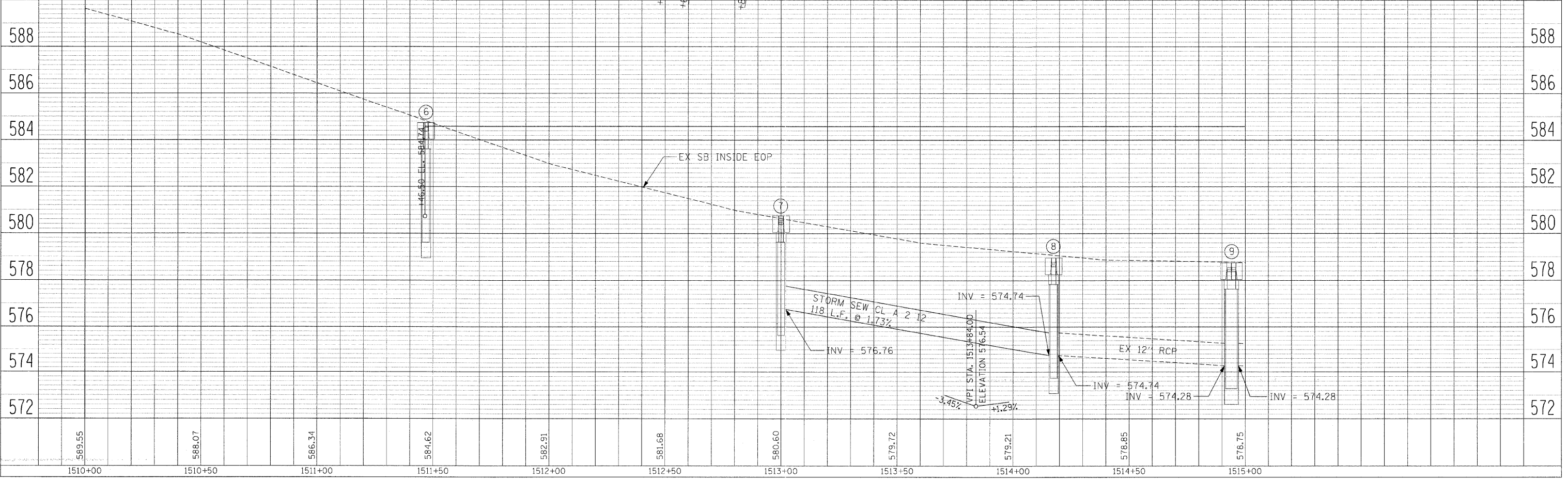
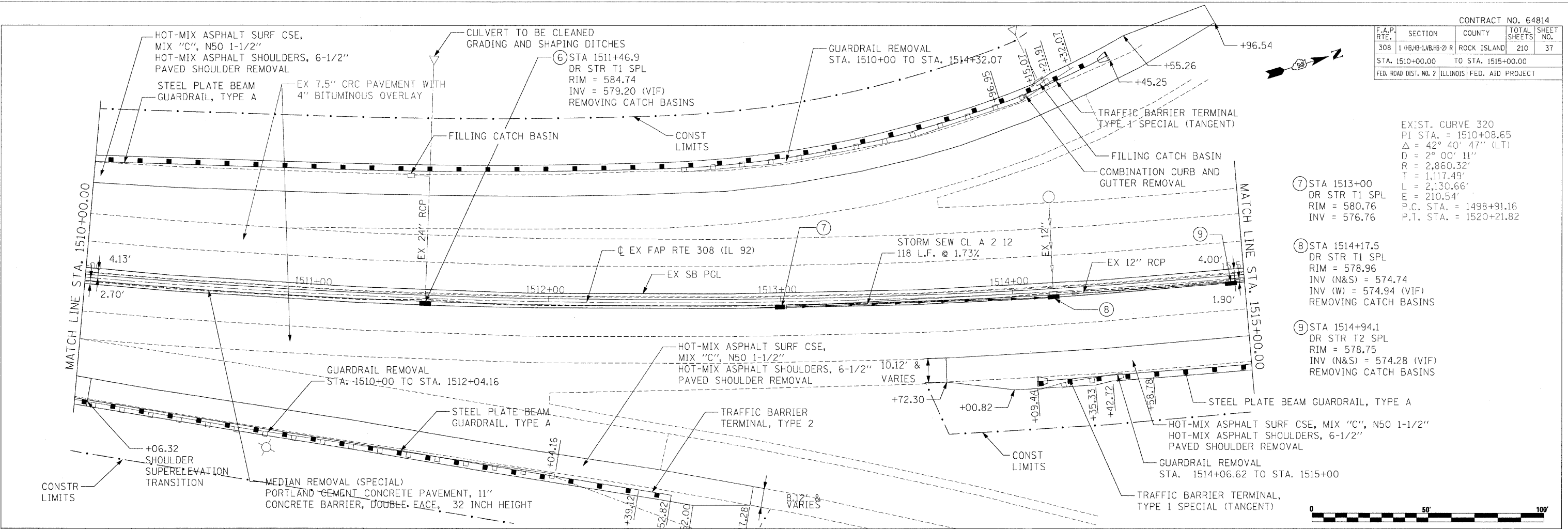

IL RTE 92 PLAN & PROFILE - STA 1510+00 TO STA 1515+00

F.A.P. RTE.	SECTION	COUNTY	TOTAL SHEETS	SHEET NO.
308	1 (06,10,14,18,22) R	ROCK ISLAND	210	38
STA. 1515+00.00 TO STA. 1521+00.00				
FED. ROAD DIST. NO. 2 ILLINOIS FED. AID PROJECT				

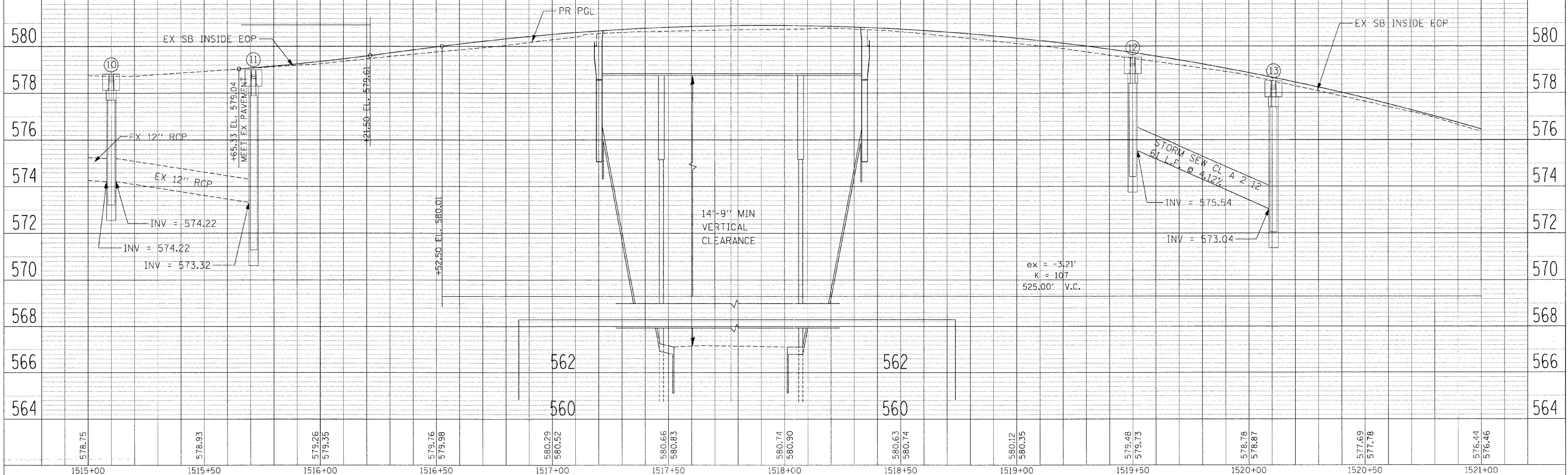
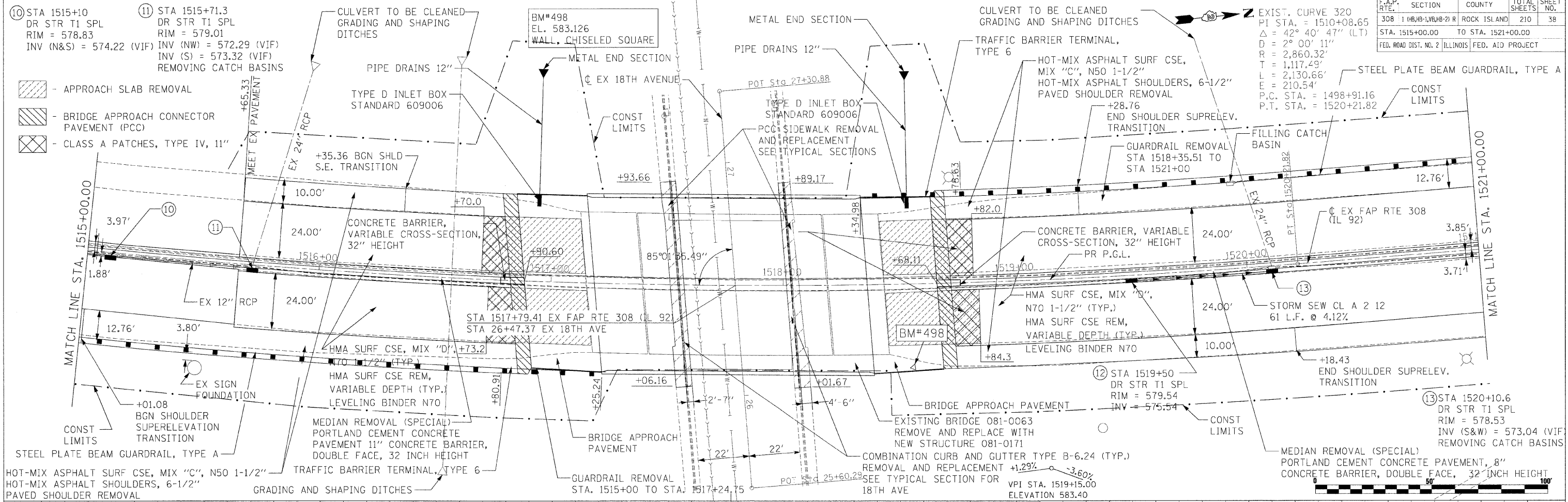

IL RTE 92 PLAN & PROFILE - STA 1515+00 TO 1521+00

DATE	BY	REVISION

DATE	BY	REVISION

PLOT DATE = 8/27/15
 FILE NAME = 8151515
 PLOT SCALE = 8/3200
 USER NAME = BJUSERS

F.A.P. RTE.	SECTION	COUNTY	TOTAL SHEETS	SHEET NO.
308	1 (HB, HB-L, VB, HB-2) R	ROCK ISLAND	210	39
STA. 1521+00.00		TO STA. 1527+00.00		
FED. ROAD DIST. NO. 2		ILLINOIS FED. AID PROJECT		

PLAN	SURVEYED	DATE
NO. 1		
NO. 2		
NO. 3		
NO. 4		
NO. 5		

PROFILE	SURVEYED	DATE
NO. 1		
NO. 2		
NO. 3		
NO. 4		
NO. 5		

PLOT DATE = 8/24/85
 FILE NAME = 8/FILEL8
 PLOT SCALE = 8/SCALE8
 USER NAME = 8/USERS

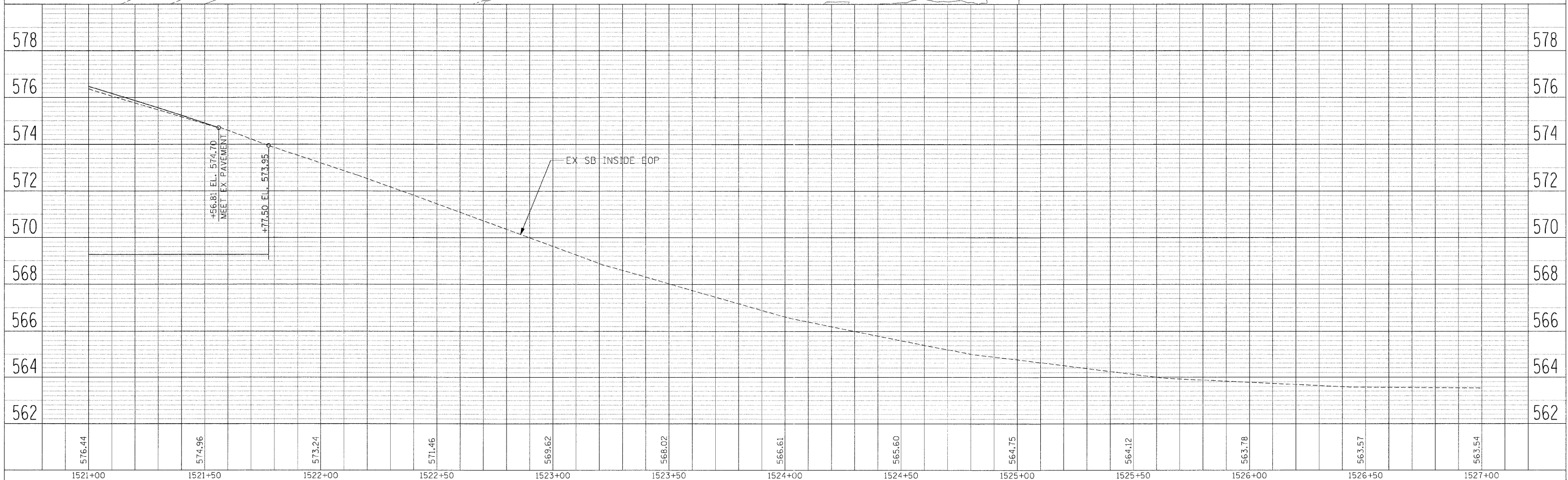
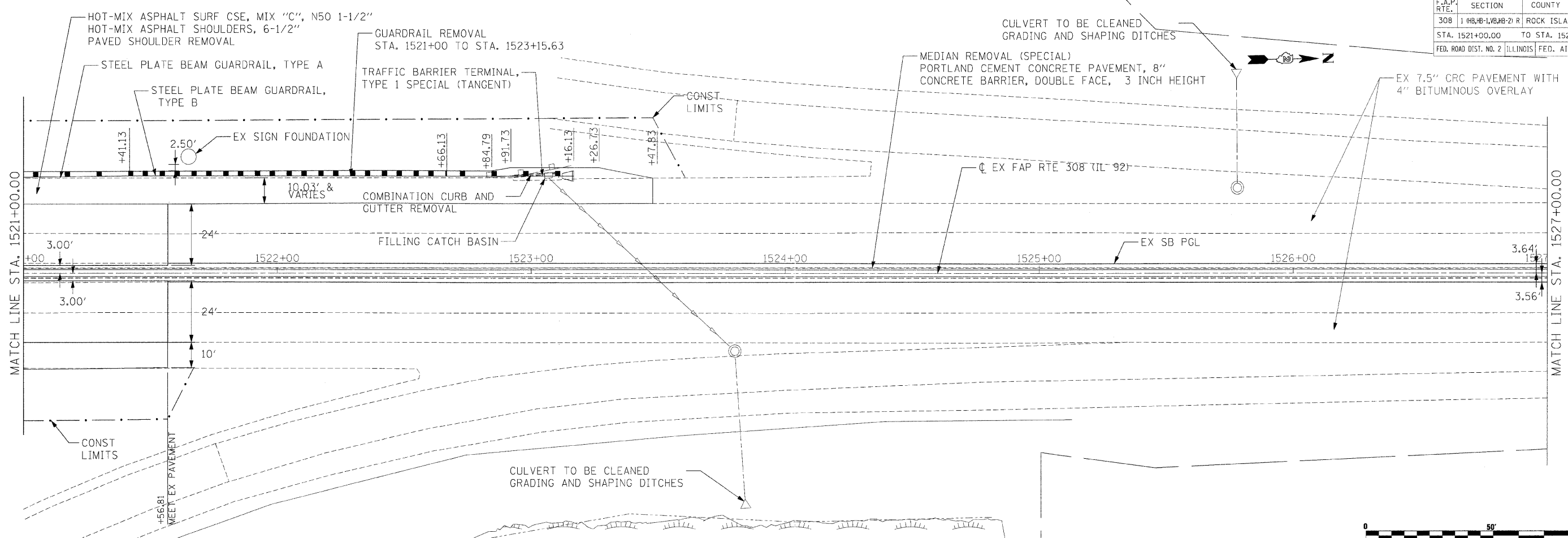

IL RTE 92 PLAN & PROFILE - STA 1521+00 TO STA 1527+00

F.A.P. RTE.	SECTION	COUNTY	TOTAL SHEETS	SHEET NO.
308	1 0B, 1B-1, 1B, 1B-2 R	ROCK ISLAND	210	40
STA. 1527+00.00		TO STA. 1533+00.00		
FED. ROAD DIST. NO. 2		ILLINOIS		FED. AID PROJECT

PLAN	SURVEYED	BY	DATE
NO. _____	PLotted _____	_____	_____
NOTE BOOK NO. _____	BY _____	_____	_____
NO. _____	FILED _____	_____	_____
	DATE _____	_____	_____

PROFILE	SURVEYED	BY	DATE
NO. _____	PLotted _____	_____	_____
NOTE BOOK NO. _____	BY _____	_____	_____
NO. _____	FILED _____	_____	_____
	DATE _____	_____	_____

PLOT DATE = 8/01/88
 FILE NAME = 81LE18
 PLOT SCALE = 8/SCALE
 USER NAME = 8USER8

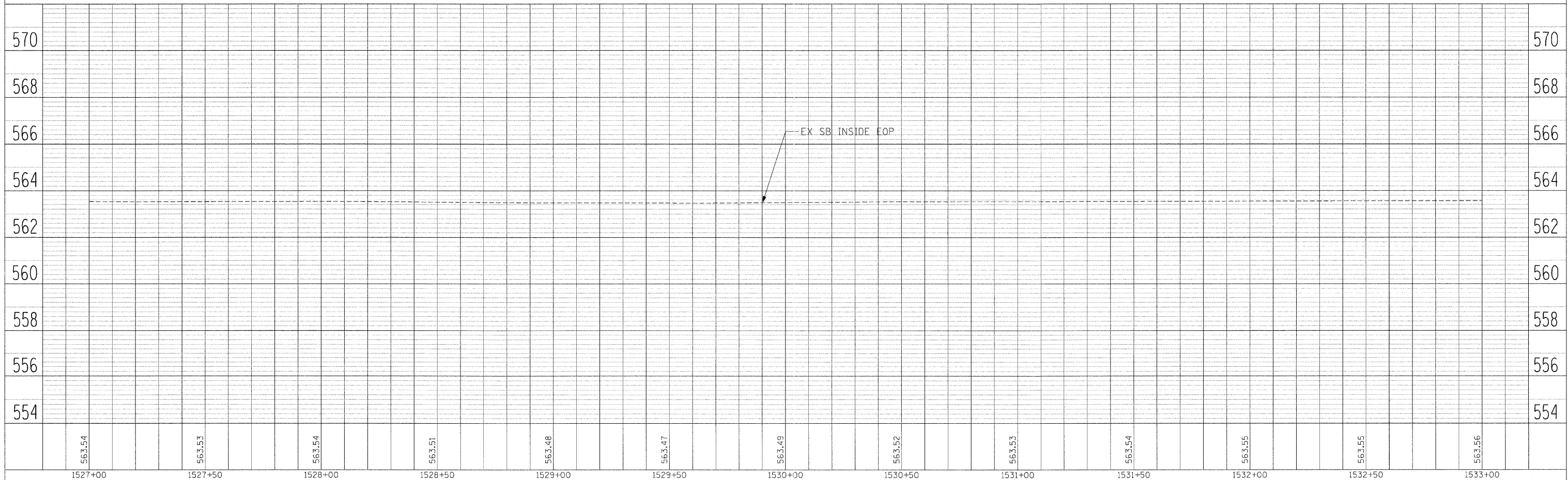
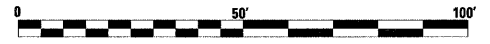
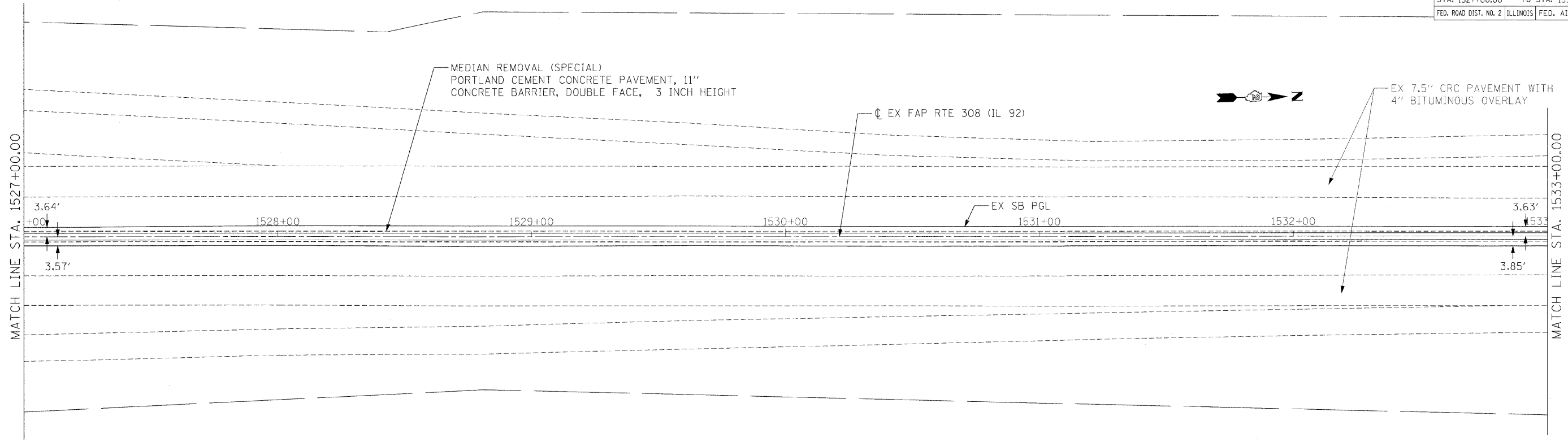

IL RTE 92 PLAN & PROFILE - STA 1527+00 TO STA 1533+00

F.A.P. RTE.	SECTION	COUNTY	TOTAL SHEETS	SHEET NO.
308	1 08, 1B, 2 R	ROCK ISLAND	210	41
STA. 1533+00.00		TO STA. 1539+00.00		
FED. ROAD DIST. NO. 2		ILLINOIS FED. AID PROJECT		



PLAN	SURVEYED	BY	DATE
NO.			
NOTE BOOK			
NO.			
FILE NAME			
USER NAME			

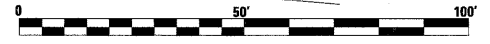
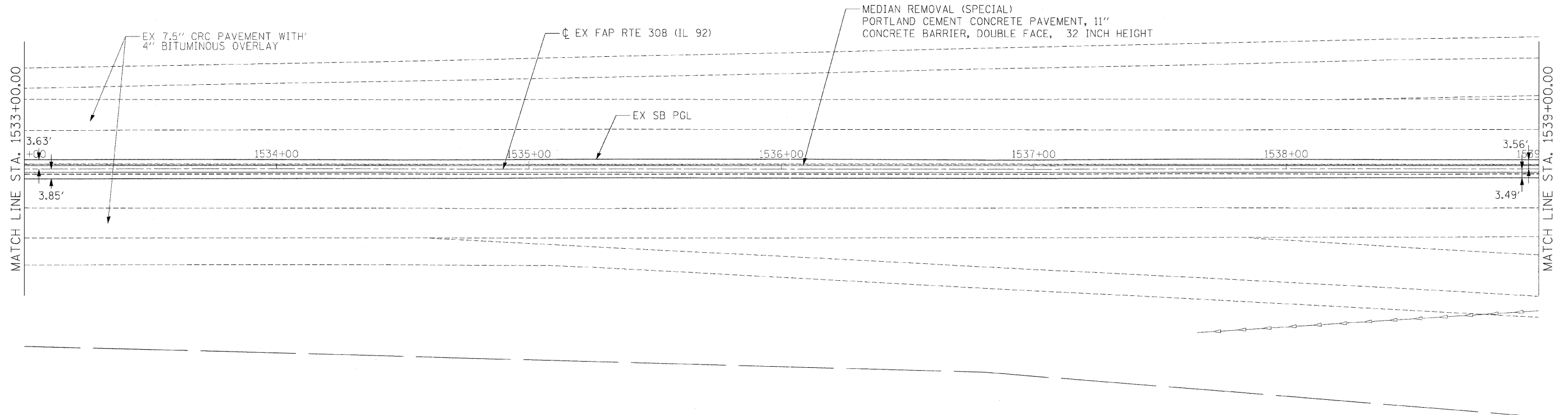

PROFILE	SURVEYED	BY	DATE
NO.			
NOTE BOOK			
NO.			
FILE NAME			
USER NAME			

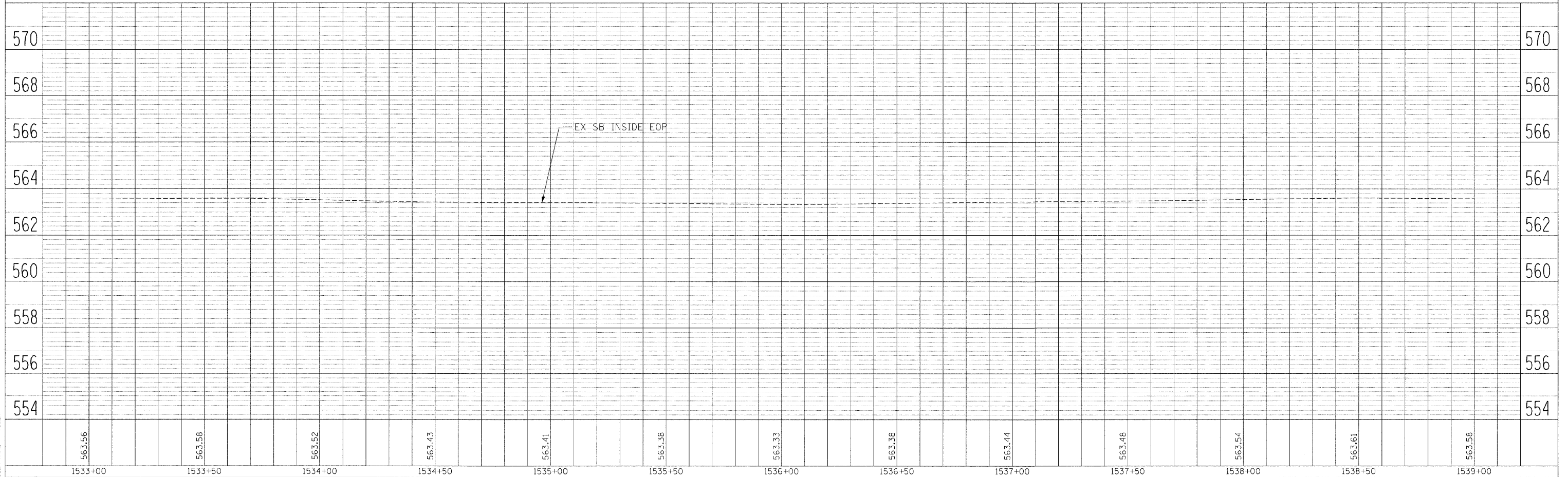

PLOT DATE = #DATE#
 FILE NAME = #FILE#
 PLOT SCALE = #SCALE#
 USER NAME = #USER#

F.A.P. RTE.	SECTION	COUNTY	TOTAL SHEETS	SHEET NO.
308	1 (H&H-B-LV&H-B-2) R	ROCK ISLAND	210	42
STA. 1539+00.00 TO STA. 1545+00.00				
FED. ROAD DIST. NO. 2 ILLINOIS FED. AID PROJECT				

PLAN	DATE
SURVEYED	
PLOTTED	
CHECKED	
BY	
NO. _____	
FILE NAME _____	
DATE _____	

PROFILE	DATE
SURVEYED	
PLOTTED	
CHECKED	
BY	
NO. _____	
FILE NAME _____	
DATE _____	

PLOT DATE = 8/27/14
 FILE NAME = 8/27/14
 PLOT SCALE = 8/27/14
 USER NAME = 8/27/14

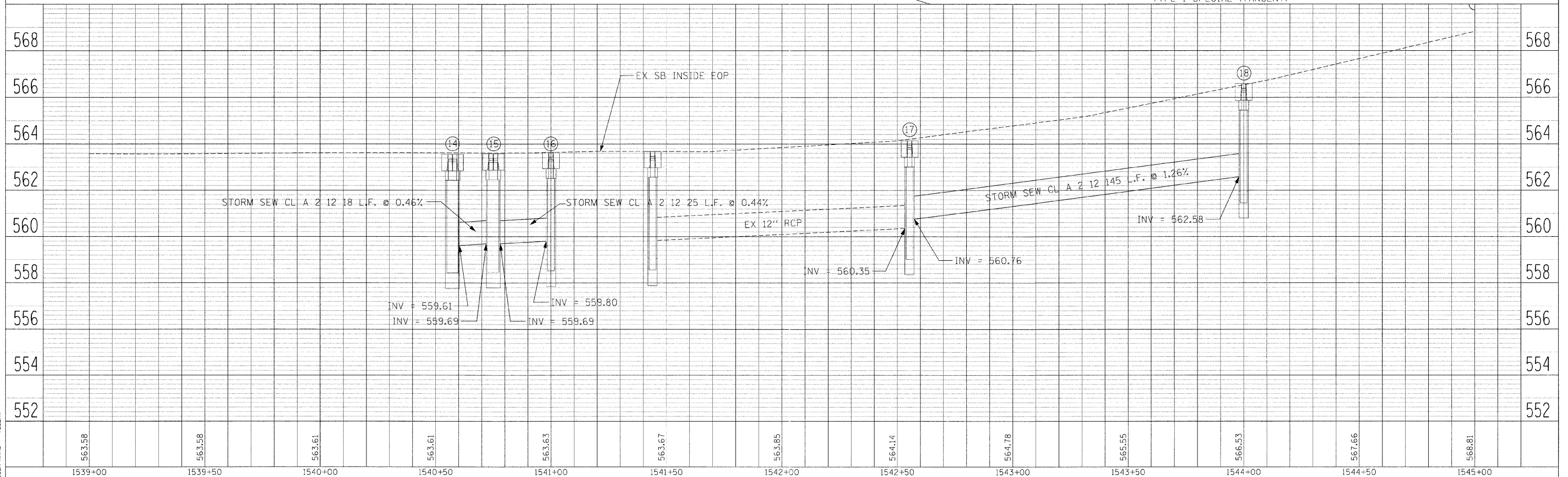
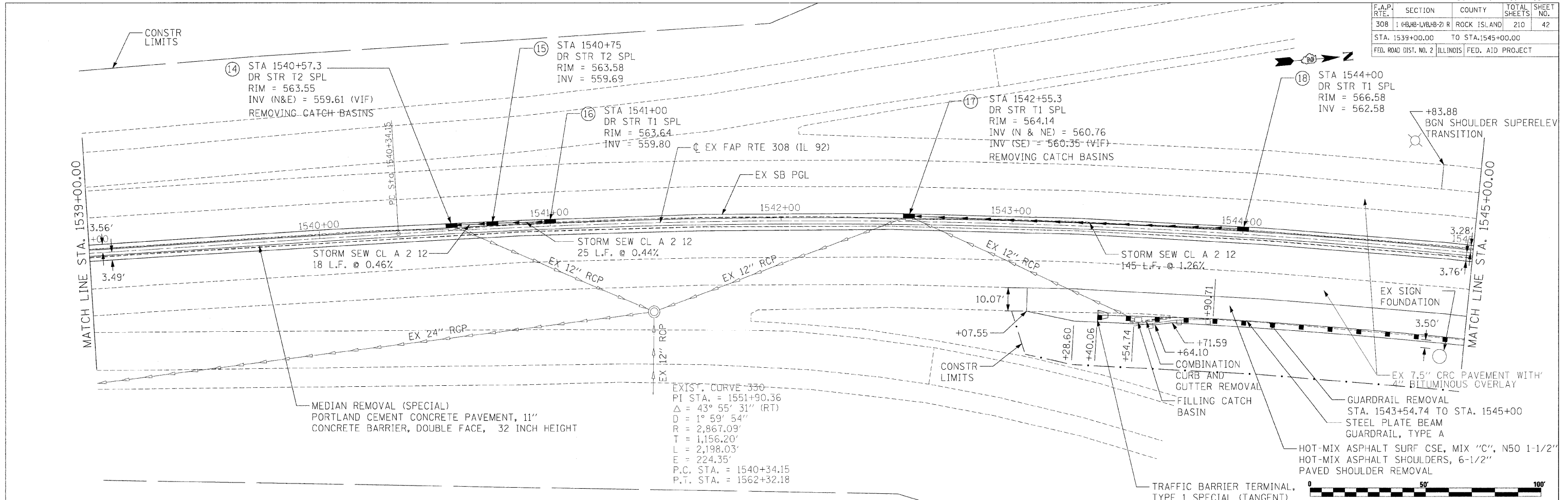

IL RTE 92 PLAN & PROFILE - STA 1539+00 TO STA 1545+00

CONTRACT NO. 64814	
F.A.P. SECTION	TOTAL SHEETS
308 1 (H&H-1, H&H-2) R	210 43
COUNTY ROCK ISLAND	
STA. 1545+00.00 TO STA. 1551+00.00	
FED. ROAD DIST. NO. 2 ILLINOIS FED. AID PROJECT	

PLAN SUPERVISED BY: _____ DATE: _____
 CHECKED BY: _____
 NO. OF SHEETS: _____
 CHECKED BY: _____
 NO. OF SHEETS: _____
 NAME: _____

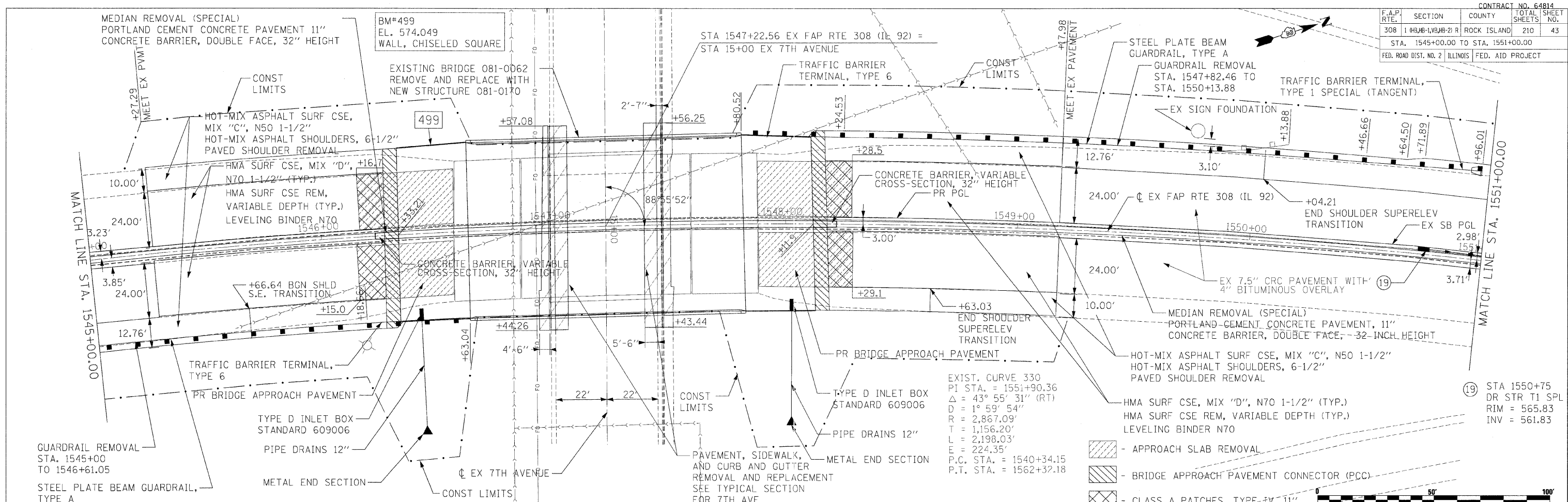

EXIST. CURVE 330
 PI STA. = 1551+90.36
 $\Delta = 43^\circ 55' 31''$ (RT)
 $D = 1^\circ 59' 54''$
 $R = 2,867.09'$
 $T = 1,156.20'$
 $L = 2,198.03'$
 $E = 224.35'$
 P.C. STA. = 1540+34.15
 P.T. STA. = 1562+32.18

- APPROACH SLAB REMOVAL
- BRIDGE APPROACH PAVEMENT CONNECTOR (PCC)
- CLASS A PATCHES, TYPE-IV, 11"

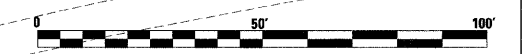

PROF. REVIEWED BY: _____ DATE: _____
 NO. OF SHEETS: _____
 CHECKED BY: _____
 NO. OF SHEETS: _____
 NAME: _____

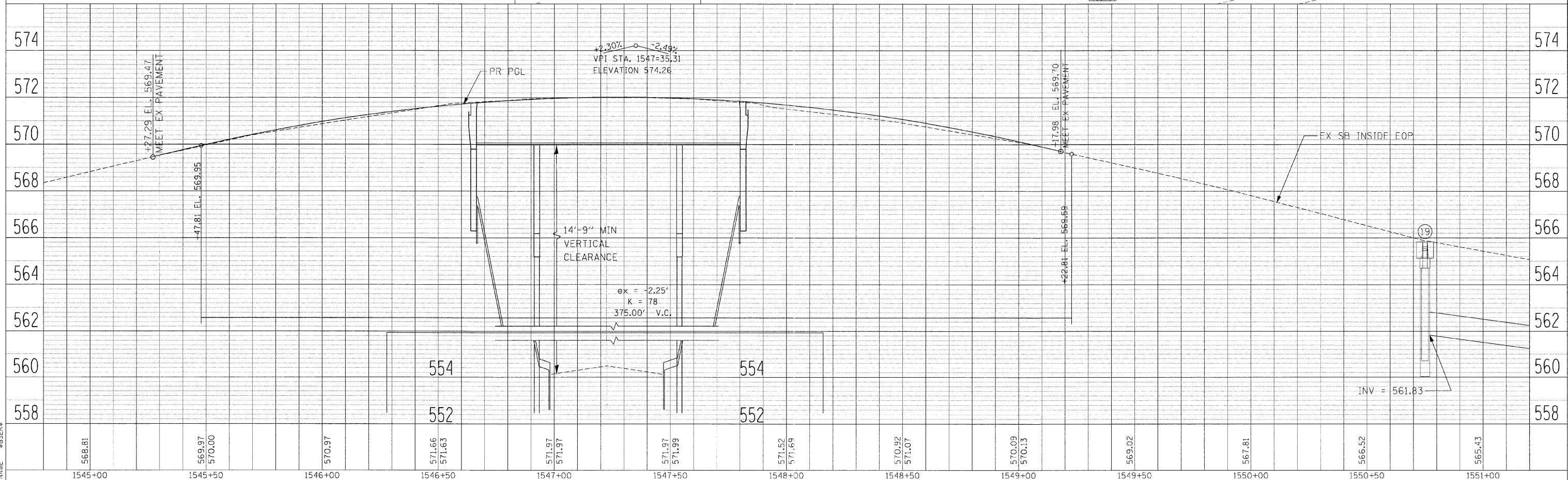

PLOT DATE: _____ \$BATES\$
 FILE NAME: _____ \$RILEY\$
 PLOT SCALE: _____ \$SCALE\$
 USER NAME: _____ \$USER\$

IL RTE 92 PLAN & PROFILE - STA 1545+00 TO 1551+00

F.A.P. RTE.	SECTION	COUNTY	TOTAL SHEETS	SHEET NO.
308	1 00B, HB-1, WB, HB-21 R	ROCK ISLAND	210	44
STA. 1551+00.00 TO STA. 1557+00.00				
FED. ROAD DIST. NO. 2 ILLINOIS FED. AID PROJECT				

BM#400
EL. 570.010
WALL, CHISELED SQUARE

PLAN	DATE	BY
SURVEYED		
NOTE BOOK		
NO. _____		

PROFILE	DATE	BY
SURVEYED		
NOTE BOOK		
NO. _____		

PLOT DATE = 08/28/08
FILE NAME = 08FILES
SCALE = 1"=40'
USER NAME = JGIBERT

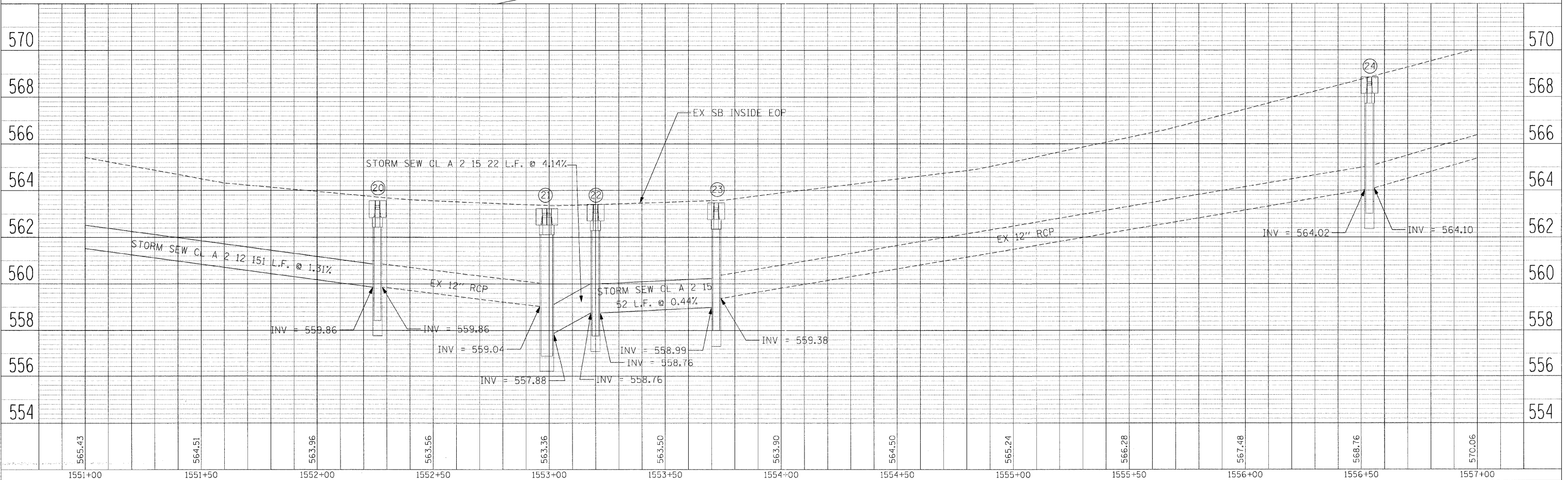
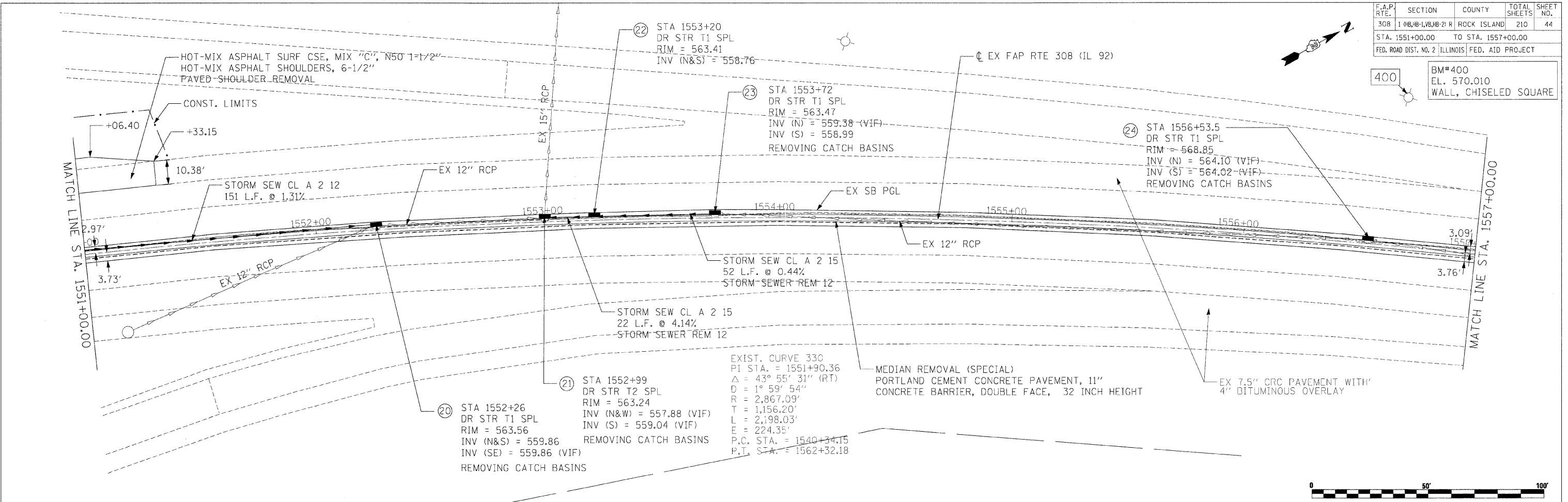

IL RTE 92 PLAN & PROFILE - STA 1551+00 TO STA 1557+00

F.A.P. RTE.	SECTION	COUNTY	TOTAL SHEETS	SHEET NO.
308	1 (H&H-1, V&H-2) R	ROCK ISLAND	210	45
STA. 1557+00.00		TO STA. 1561+63.55		
FED. ROAD DIST. NO. 2 ILLINOIS FED. AID PROJECT				

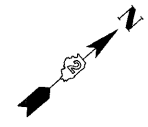

PLAN	REVISION	DATE
NO. _____	BY _____	DATE _____

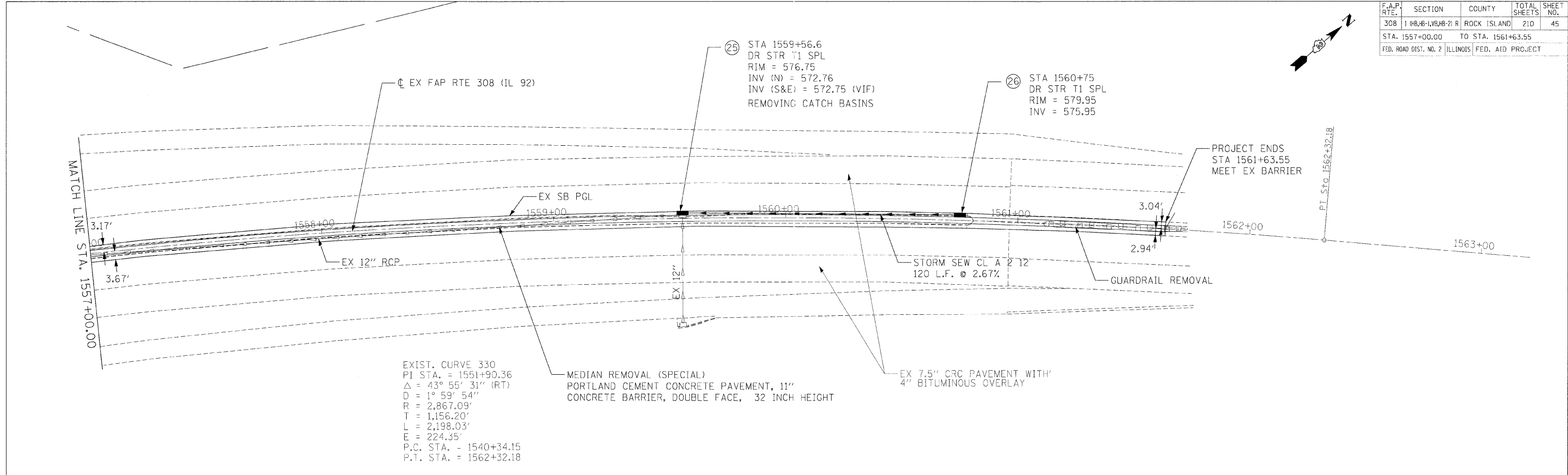

EXIST. CURVE 330
 PI STA. = 1551+90.36
 $\Delta = 43^\circ 55' 31''$ (RT)
 $D = 1^\circ 59' 54''$
 $R = 2,867.09'$
 $T = 1,156.20'$
 $L = 2,198.03'$
 $E = 224.35'$
 P.C. STA. = 1540+34.15
 P.T. STA. = 1562+32.18

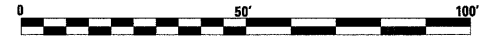

PROFILE	REVISION	DATE
NO. _____	BY _____	DATE _____

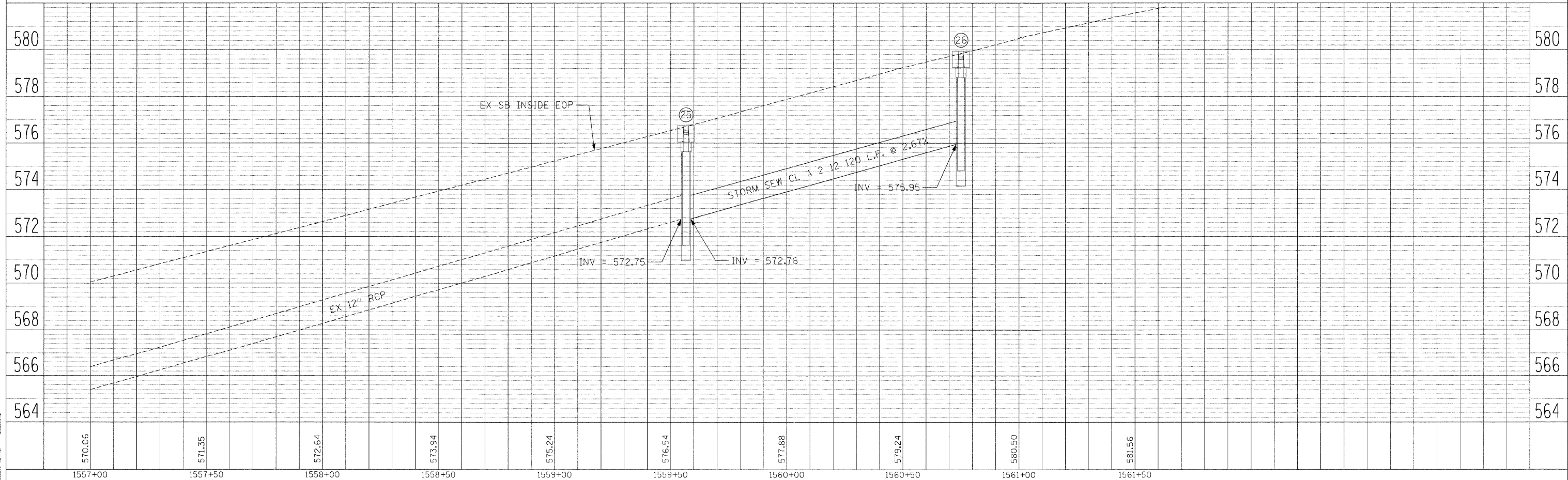

PLOT DATE = 8/24/24
 FILE NAME = 8/24/24
 PLOT SCALE = 8/24/24
 USER NAME = 8/24/24

F.A.P. RTE.	SECTION	COUNTY	TOTAL SHEETS	SHEET NO.
308	1 (NB, SB, WB, EB-2) R	ROCK ISLAND	210	46
STA. N/A		TO STA. N/A		
FED. ROAD DIST. NO. 2		ILLINOIS FED. AID PROJECT		

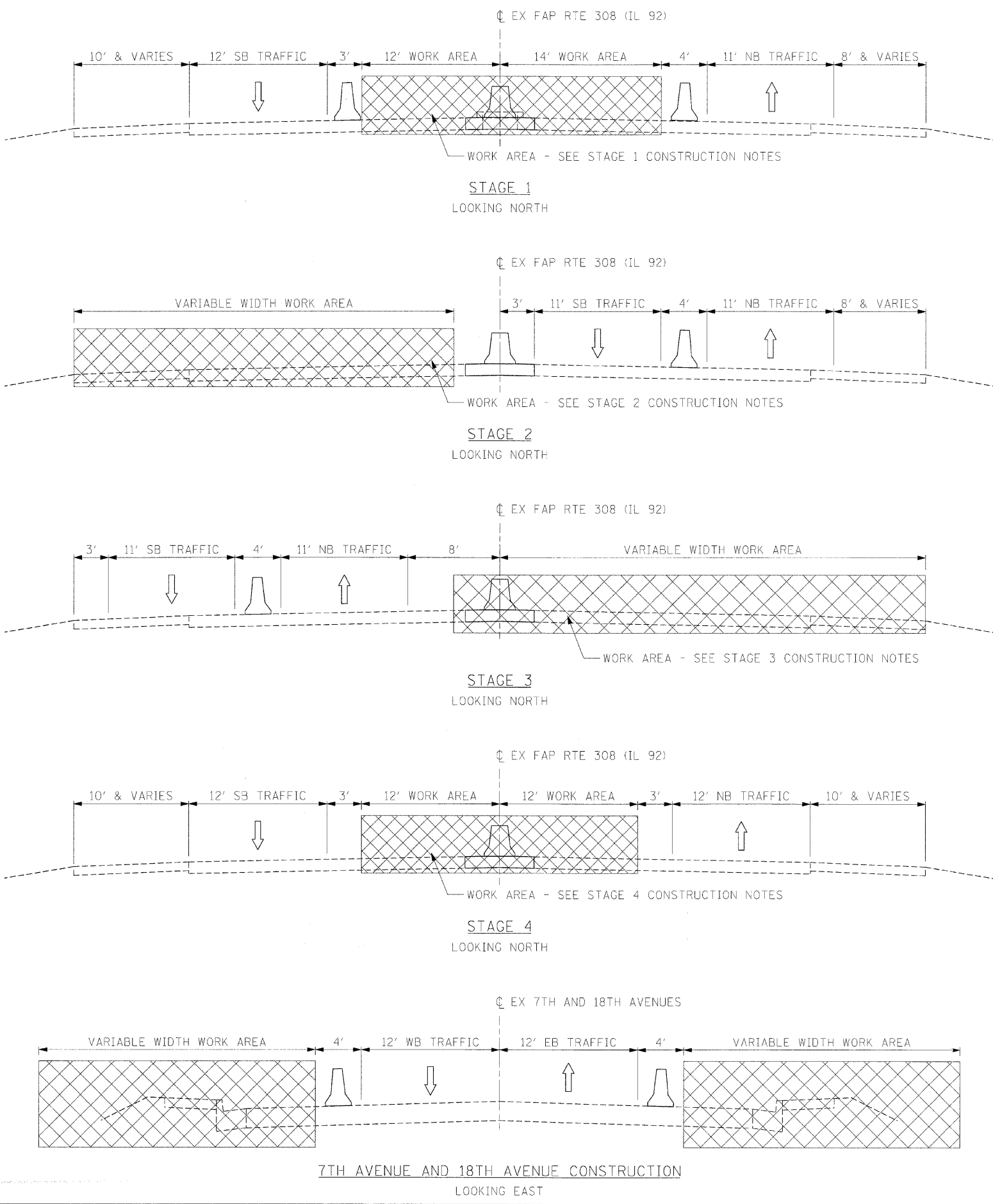

PRE-STAGE 1

MILL AND RESURFACE NORTHBOUND LANES ON 31ST AVE, 18TH AVE, AND 7TH AVE BRIDGE DECKS ONE LANE AT A TIME USING IDOT STANDARDS 701400 AND 701401

STAGE 1

CLOSE NORTHBOUND INSIDE LANE UTILIZING IDOT STANDARDS 701400 AND 701401.
CLOSE SOUTHBOUND INSIDE LANE UTILIZING IDOT STANDARDS 701606
CONSTRUCT MEDIAN PAVEMENT AND DRAINAGE STRUCTURES.

REMOVE EXISTING RAISED CONCRETE MEDIAN AND CONSTRUCT 11" PCC PAVEMENT AT THE FOLLOWING LOCATIONS:

- STA. 1485+51.03 TO IAIS BRIDGE APPROACH
- IAIS BRIDGE APPROACH TO 18TH AVENUE BRIDGE APPROACH
- 18TH AVENUE BRIDGE APPROACH TO 7TH AVENUE BRIDGE APPROACH
- 7TH AVENUE BRIDGE APPROACH TO STA. 1561+63.55

CONSTRUCT CONCRETE BARRIER, DOUBLE FACE, 32 INCH HEIGHT AT THE FOLLOWING LOCATIONS: STA. 1491+00.00 TO STA. 1504+66.73
STA. 1509+50.85 TO STA. 1515+85.36
STA. 1519+73.29 TO STA. 1545+27.29
STA. 1549+17.98 TO STA. 1556+00.00

INSTALL 262.5 FEET OF TEMPORARY STEEL PLATE BEAM GUARDRAIL, TYPE A WITH 30:1 TAPER FROM NORTHWEST PARAPET WALL OF EX NB BRIDGE OVER 31ST AVENUE. INSTALL TEMPORARY TRAFFIC BARRIER TERMINAL, TYPE 6A TO CONNECT GUARDRAIL TO PARAPET WALL AND TEMPORARY TRAFFIC BARRIER TERMINAL, TYPE 1 (SPECIAL) AT NORTH END OF GUARDRAIL.

STAGE 2

SHIFT TRAFFIC TO NORTHBOUND LANES UTILIZING IDOT STANDARDS 701400, 701411, 701416, AND 701606.

CONSTRUCT SOUTHBOUND BRIDGE AND APPROACH OVER 31ST AVENUE AND SOUTHBOUND LANES OF BRIDGES AND APPROACHES OVER IAIS RAILROAD, 18TH AVENUE, AND 7TH AVENUE.

RESURFACE SOUTHBOUND LANES ADJACENT TO BRIDGE APPROACH SLABS AT LOCATIONS SHOWN ON THE PLAN AND PROFILE SHEETS. RECONSTRUCT SHOULDERS ALONG SOUTHBOUND LANES AT LOCATIONS SHOWN ON THE PLAN AND PROFILE SHEETS.

CONSTRUCT STEEL PLATE BEAM GUARDRAIL AND ASSOCIATED END TERMINALS ASSOCIATED WITH SOUTHBOUND LANES AT LOCATIONS SHOWN ON THE PLAN AND PROFILE SHEETS.

INSTALL 262.5 FEET OF TEMPORARY STEEL PLATE BEAM GUARDRAIL, TYPE A WITH 30:1 TAPER FROM SOUTHWEST PARAPET WALL OF EX SB BRIDGE OVER 31ST AVENUE. INSTALL TEMPORARY TRAFFIC BARRIER TERMINAL, TYPE 6A TO CONNECT GUARDRAIL TO PARAPET WALL AND TEMPORARY TRAFFIC BARRIER TERMINAL, TYPE 1 (SPECIAL) AT SOUTH END OF GUARDRAIL.

STAGE 3

SHIFT TRAFFIC TO SOUTHBOUND LANES UTILIZING IDOT STANDARDS 701400, 701411, 701416, AND 701606.

CONSTRUCT NORTHBOUND BRIDGE AND APPROACH OVER 31ST AVENUE AND NORTHBOUND LANES OF BRIDGES AND APPROACHES OVER IAIS RAILROAD, 18TH AVENUE, AND 7TH AVENUE.

RESURFACE NORTHBOUND LANES ADJACENT TO BRIDGE APPROACH SLABS AT LOCATIONS SHOWN ON THE PLAN AND PROFILE SHEETS. RECONSTRUCT SHOULDERS ALONG NORTHBOUND LANES AT LOCATIONS SHOWN ON THE PLAN AND PROFILE SHEETS.

INSTALL STEEL PLATE BEAM GUARDRAIL AND ASSOCIATED END TERMINALS ASSOCIATED WITH NORTHBOUND LANES AT LOCATIONS SHOWN ON THE PLAN AND PROFILE SHEETS.

REMOVE TEMPORARY STEEL PLATE BEAM GUARDRAIL AND ASSOCIATED TERMINALS CONSTRUCTED IN STAGE 1.

STAGE 4

CLOSE NORTHBOUND AND SOUTHBOUND INSIDE LANES UTILIZING IDOT STANDARDS 701400, 701401, AND 701606.

CONSTRUCT CONCRETE BARRIER, DOUBLE FACE, 32 INCH HEIGHT AT THE FOLLOWING LOCATIONS:

- STA. 1485+57.00 TO STA. 1491+00.00
- STA. 1504+66.73 TO IAIS BRIDGE APPROACH
- IAIS BRIDGE APPROACH TO STA. 1509+50.85
- STA. 1515+85.36 TO 18TH AVENUE BRIDGE APPROACH
- 18TH AVENUE BRIDGE APPROACH TO STA. 1519+73.29
- STA. 1545+27.29 TO 7TH AVENUE BRIDGE APPROACH
- 7TH AVENUE BRIDGE APPROACH TO STA. 1549+17.98
- STA. 1556+00.00 TO STA. 1561+63.55

INSTALL STEEL PLATE BEAM GUARDRAIL AND ASSOCIATED TERMINALS FROM STA. 1481+71.14 TO STA. 1485+51.03.

REMOVE TEMPORARY STEEL PLATE BEAM GUARDRAIL AND ASSOCIATED TERMINALS CONSTRUCTED IN STAGE 2.

7TH AVENUE AND 18TH AVENUE CONSTRUCTION

CLOSE EASTBOUND AND WESTBOUND OUTSIDE LANES UTILIZING IDOT STANDARD 701606.

REMOVE EXISTING SIDEWALK, CURB AND GUTTER, AND PAVEMENT AS NECESSARY TO REMOVE EXISTING PIER FOUNDATIONS. REMOVE EXISTING PIER FOUNDATIONS, CONSTRUCT PROPOSED PIERS, AND CONSTRUCT NEW SIDEWALK, CURB AND GUTTER, AND PAVEMENT TO REPLACE REMOVED PORTIONS.

NIGHTTIME CLOSURES AS NEEDED TO REMOVE AND SET BRIDGE BEAMS.

31ST AVENUE CONSTRUCTION

CLOSE EASTBOUND AND WESTBOUND SHOULDERS UTILIZING IDOT STANDARD 701006.

NIGHTTIME CLOSURES AS NEEDED TO REMOVE AND SET BRIDGE BEAMS.

REVISIONS	
NAME	DATE

ILLINOIS DEPARTMENT OF TRANSPORTATION

IL 92 STAGING
TYPICAL SECTIONS
AND NOTES

SCALE: N.T.S.
DATE: 12/08/06

DRAWN BY: WAJ
CHECKED BY: MGZ

PLOT DATE = 12/08/06
PLOT NAME = ILL92 STAGING
PLOT SCALE = AS SHOWN
USER NAME = WAJ

F.A.P. RTE.	SECTION	COUNTY	TOTAL SHEETS	SHEET NO.
308	118B-1,18B-2 R	ROCK ISLAND	210	47
STA. N/A	TO STA. N/A			
FED. ROAD DIST. NO. 2		ILLINOIS	FED. AID PROJECT	

31ST AVE.

IAIS RAILROAD

18TH AVE.

7TH AVE.

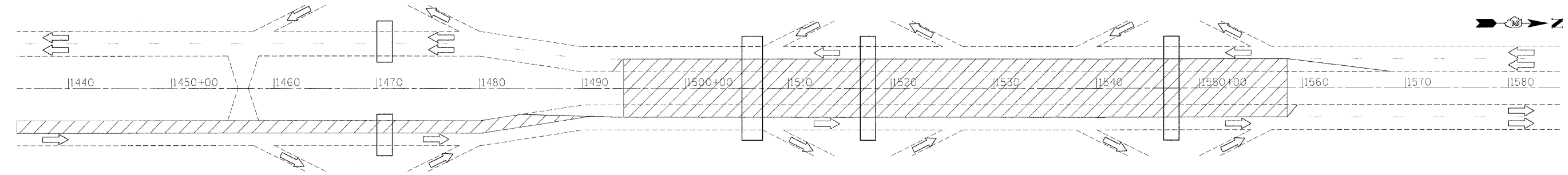

STAGE 1
TRAFFIC ON OUTSIDE LANES

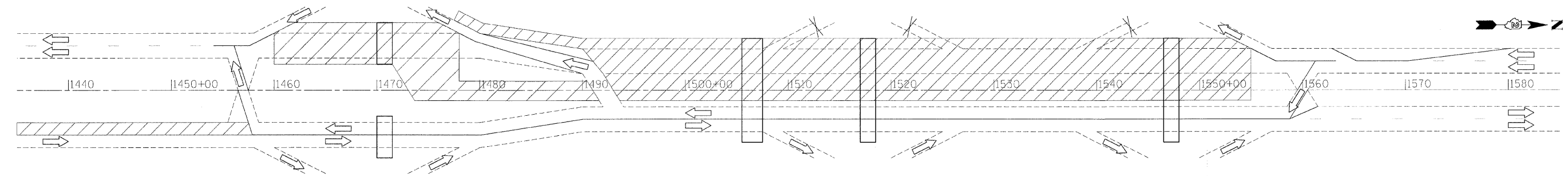

STAGE 2
TRAFFIC ON NORTHBOUND LANES

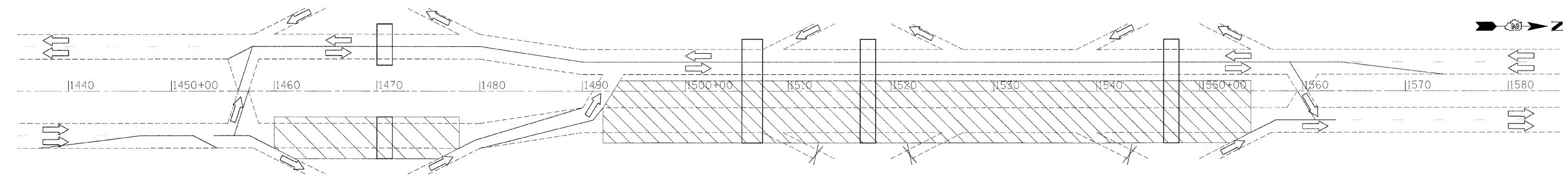

STAGE 3
TRAFFIC ON SOUTHBOUND LANES

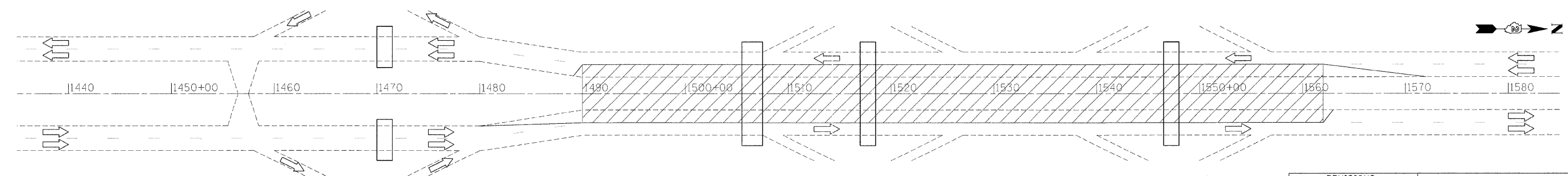

STAGE 4
TRAFFIC ON OUTSIDE LANES

- WORK AREA

REVISIONS	
NAME	DATE

ILLINOIS DEPARTMENT OF TRANSPORTATION

IL 92 STAGING
SCHEMATIC OVERVIEW

SCALE: N.T.S.
DATE: 12/08/06

DRAWN BY: WAJ
CHECKED BY: MGZ

PLOT DATE = #DATE#
PLOT SCALE = #SCALE#
PLOT USER = #USER#

F.A.P. RTE.	SECTION	COUNTY	TOTAL SHEETS	SHEET NO.
308	11B,11B-1,11B-2,11B-3	ROCK	210	48
STA.		TO STA.		
FED. ROAD DIST. NO. 2 ILLINOIS FED. AID PROJECT				

RAMP CLOSURE DETAILS

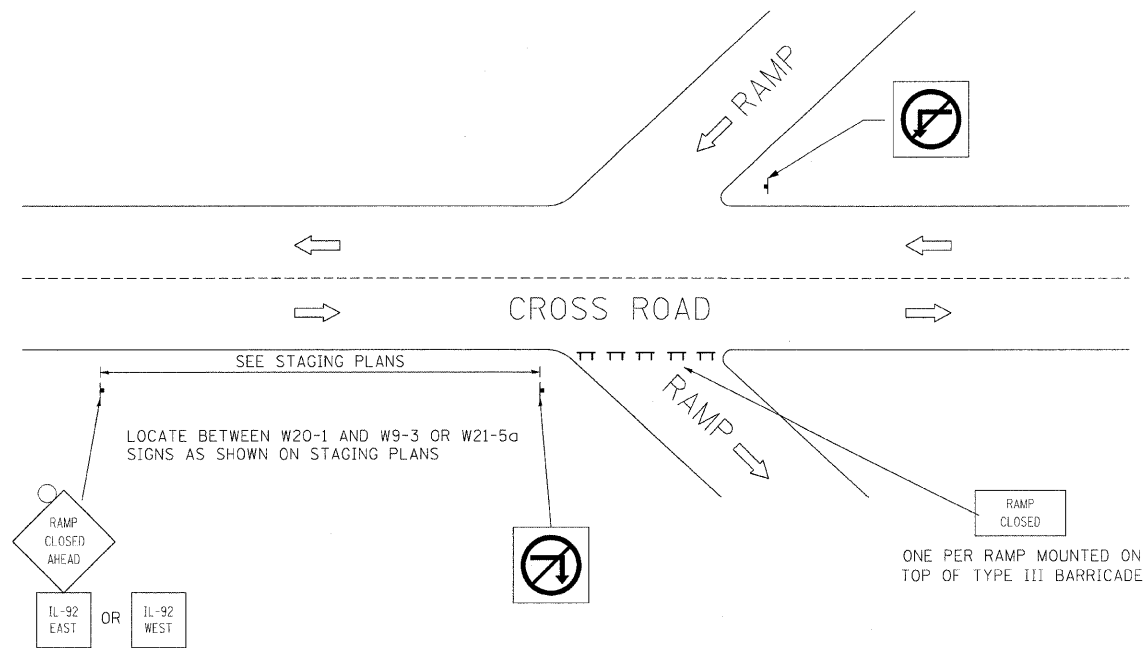

LEGEND
 □ TYPE III BARRICADE WITH FLASHING LIGHTS
 ▽ WARNING SIGN ASSEMBLY WITH FLASHING LIGHT

SIGN DETAILS

48.0" across sides 2.3" Radius, 0.9" Border, 0.6" Indent, Black on Orange;
 [RAMP] D; [CLOSED] D; [AHEAD] D;
 SCALE: 1/2" = 1'

1.5" Radius, 0.6" Border, 0.4" Indent, Black on White;
 [RAMP] C; [CLOSED] C;
 SCALE: 1/2" = 1'

W12-1103 (Width is 80);
 No border, Black on White;
 "MAX WIDTH"; [AHEAD] D;
 No border, Black on Orange;
 "XX'-XX" D;
 No border, Black on White;
 "X MILES"; [AHEAD] D;
 SCALE: 1/2" = 1'

W12-1102 ;
 48.0" across sides 1.9" Radius, 0.8" Border, 0.5" Indent, Black on Orange;
 Standard Arrow Custom 10.4" X 8.1" 180L Black;
 [XX] D specified length; [J] D;
 [X] D; Standard Arrow Custom 10.4" X 8.1" 0L;
 SCALE: 1/2" = 1'

NARROW WIDTH WARNING SIGN USE ON MAINLINE

NARROW WIDTH WARNING SIGN USE ON RAMP WITH M1-1100-36 & M3-2-3015 (EAST IL-92) OR M1-1100-36 & M3-4-3015 (WEST IL-92)

6.00" Radius, 1.50" Border, 0.50" Indent, Black on Orange;
 [31ST] C; [AVE] C;
 Standard Arrow Custom 23.38" X 14.13" 30L;
 SCALE: 3/4" = 1'

6.00" Radius, 1.50" Border, 0.50" Indent, Black on Orange;
 [31ST] C; [AVE] C; [NEXT] C; [RIGHT] C;
 SCALE: 3/4" = 1'

6.00" Radius, 1.50" Border, 0.50" Indent, Black on Orange;
 [31ST] C; [AVE] C; [EXIT] C; [OPEN] C; [AHEAD] C;
 SCALE: 3/4" = 1'

SHORT-TERM ROAD CLOSURE FOR CROSS ROADS

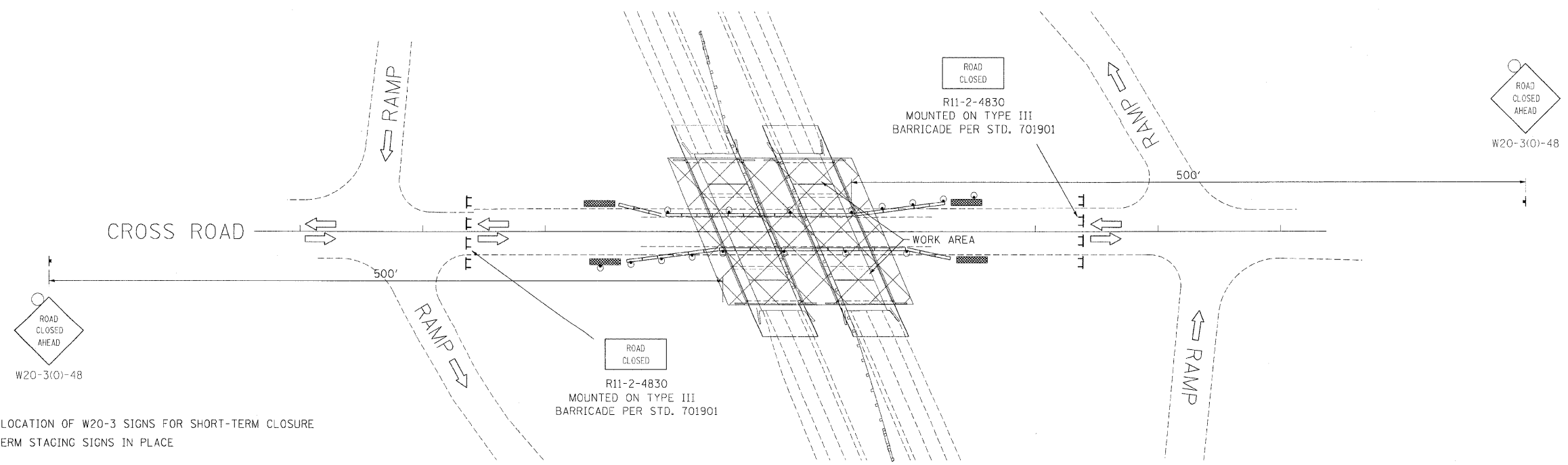

COORDINATE LOCATION OF W20-3 SIGNS FOR SHORT-TERM CLOSURE WITH LONG-TERM STAGING SIGNS IN PLACE

PLOT DATE * * * DATE * * *
 FILE NAME * * * FILE * * *
 PLOT SCALE * * * SCALE * * *
 REFERENCE * * * REF * * *

F.A.P. RTE.	SECTION	COUNTY	TOTAL SHEETS	SHEET NO.
308	10B, HB-1, VB, HB-2/R	ROCK ISLAND	210	49
STA. 1455+00.00 TO STA. 1485+00.00				
FED. ROAD DIST. NO. 2		ILLINOIS	FED. AID PROJECT	

STAGE 1

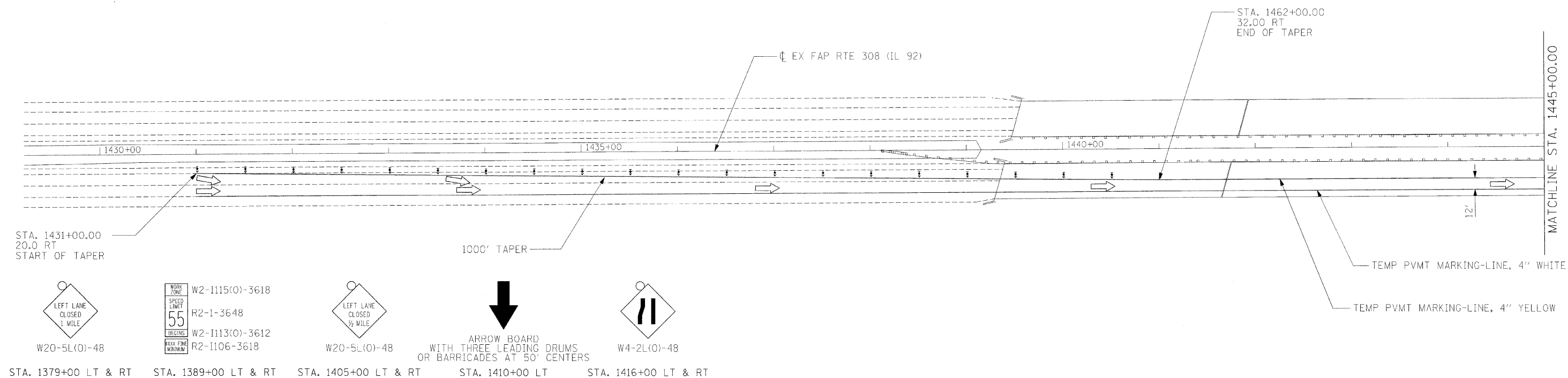

STAGE 1

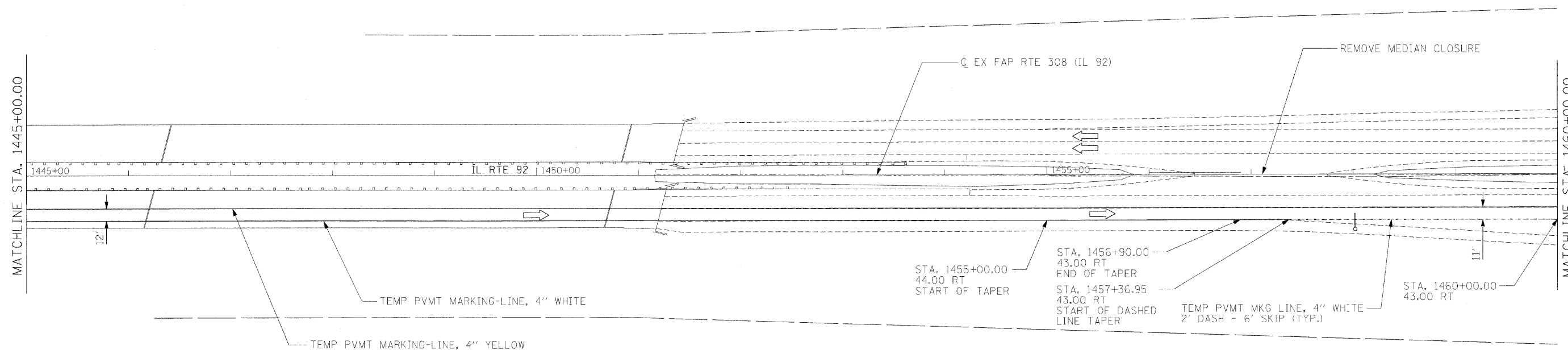

LEGEND

- ➔ DIRECTION OF TRAFFIC
- DRUM WITH STEADY BURN MONODIRECTIONAL LIGHT
- ⚡ DIRECTION INDICATOR BARRICADE WITH STEADY BURN MONODIRECTIONAL LIGHT
- ⚡ TYPE III BARRICADE WITH FLASHING MONODIRECTIONAL LIGHTS
- ▬ TEMPORARY CONCRETE BARRIER

PLOT DATE = 04/20/08
 PLOT TIME = 10:58:18
 PLOT SCALE = 1/8"=1'-0"
 USER NAME = RUSSEK

F.A.P. RTE.	SECTION	COUNTY	TOTAL SHEETS	SHEET NO.
308	10B,1B-1,VB,1B-2R	ROCK ISLAND	210	50
STA. 1455+00.00 TO STA. 1485+00.00				
FED. ROAD DIST. NO. 2		ILLINOIS	FED. AID PROJECT	

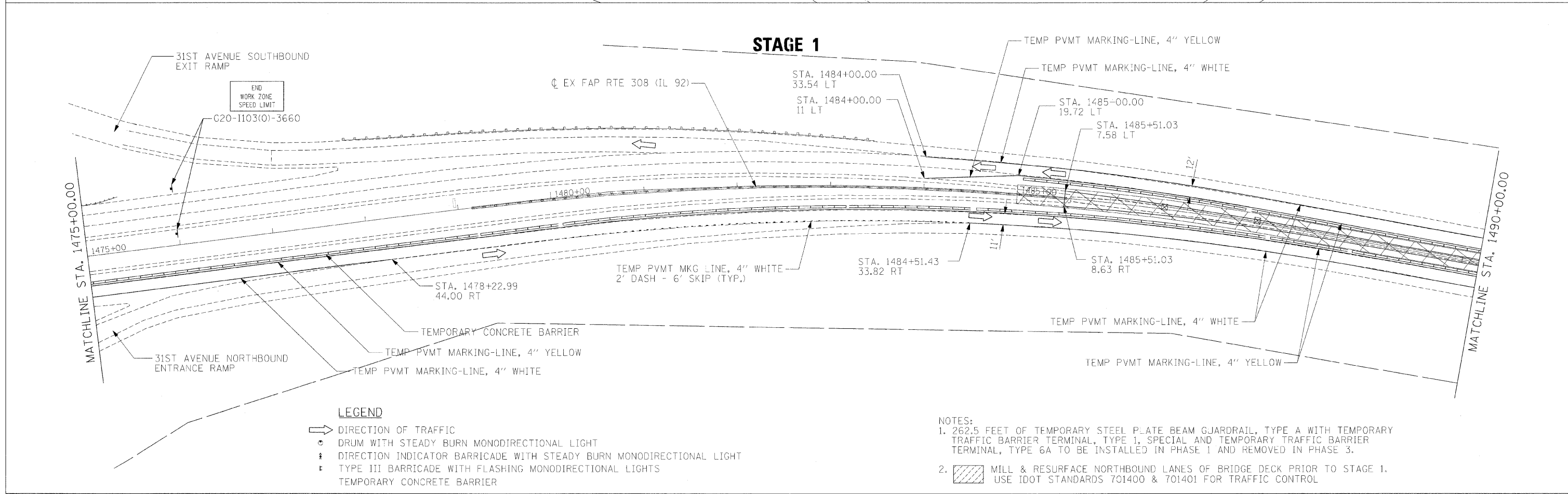
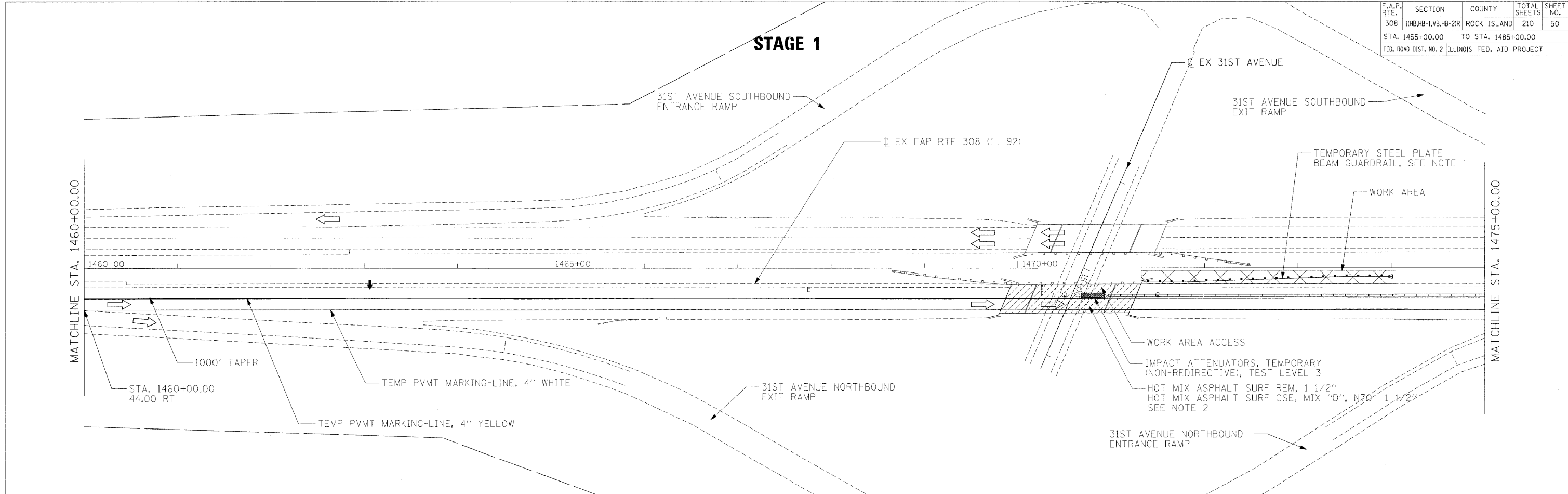

- LEGEND**
- ➔ DIRECTION OF TRAFFIC
 - DRUM WITH STEADY BURN MONODIRECTIONAL LIGHT
 - ⚡ DIRECTION INDICATOR BARRICADE WITH STEADY BURN MONODIRECTIONAL LIGHT
 - ⚡ TYPE III BARRICADE WITH FLASHING MONODIRECTIONAL LIGHTS
 - ▭ TEMPORARY CONCRETE BARRIER

- NOTES:**
1. 262.5 FEET OF TEMPORARY STEEL PLATE BEAM GUARDRAIL, TYPE A WITH TEMPORARY TRAFFIC BARRIER TERMINAL, TYPE 1, SPECIAL AND TEMPORARY TRAFFIC BARRIER TERMINAL, TYPE 6A TO BE INSTALLED IN PHASE 1 AND REMOVED IN PHASE 3.
 2. MILL & RESURFACE NORTHBOUND LANES OF BRIDGE DECK PRIOR TO STAGE 1. USE IDOT STANDARDS 701400 & 701401 FOR TRAFFIC CONTROL

PLOT DATE = #DATE#
 PLOT FILE = #FILE#
 PLOT SCALE = #SCALE#
 PLOT USER = #USER#

F.A.P. RTE.	SECTION	COUNTY	TOTAL SHEETS	SHEET NO.
308	108B,108B-1,108B-2R	ROCK ISLAND	210	51
STA. 1455+00.00 TO STA. 1485+00.00				
FED. ROAD DIST. NO. 2 ILLINOIS		FED. AID PROJECT		

STAGE 1

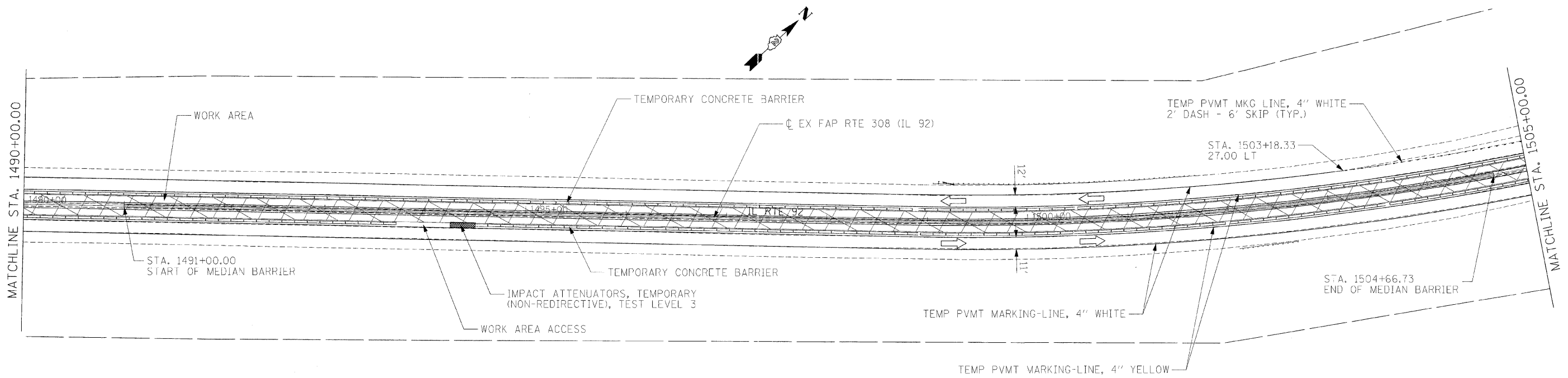

STAGE 1

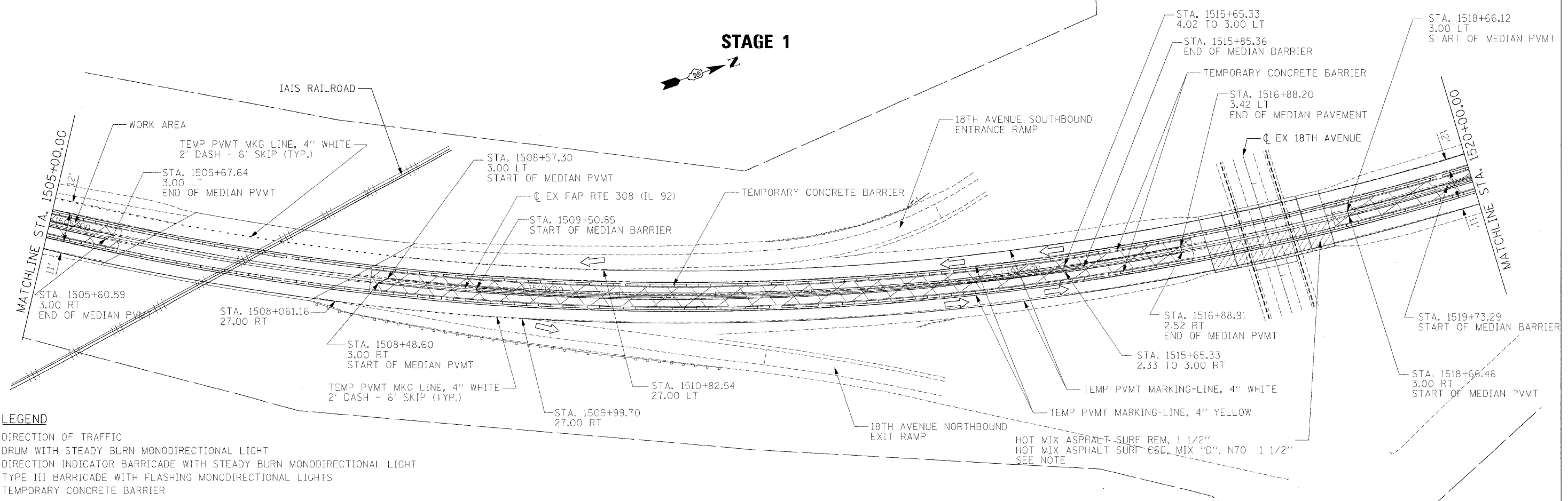

LEGEND

- ➔ DIRECTION OF TRAFFIC
- ⊙ DRUM WITH STEADY BURN MONODIRECTIONAL LIGHT
- ⚡ DIRECTION INDICATOR BARRICADE WITH STEADY BURN MONODIRECTIONAL LIGHT
- ⚡ TYPE III BARRICADE WITH FLASHING MONODIRECTIONAL LIGHTS
- ▬ TEMPORARY CONCRETE BARRIER

HOT MIX ASPHALT SURF REM, 1 1/2"
 HOT MIX ASPHALT SURF 6SE, MIX "D", N70 1 1/2"
 SEE NOTE



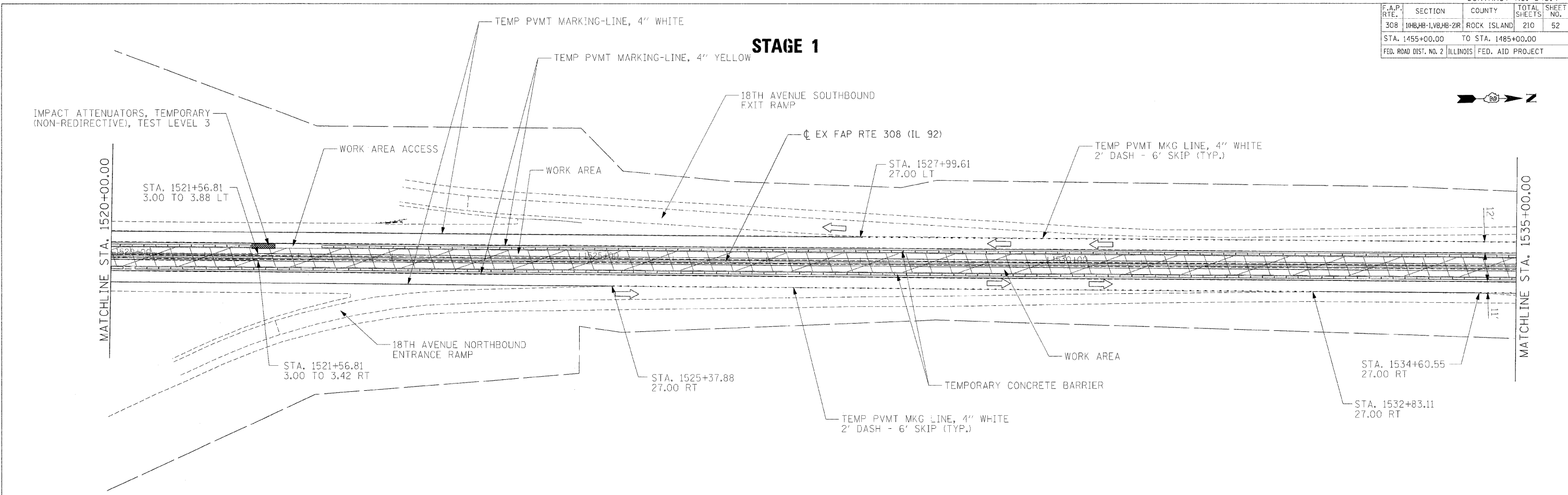

PLOT DATE = 04/25/05
 FILE NAME = 1485-51.DWG
 PLOT SCALE = 1"=40'
 USER NAME = RUSERS

F.A.P. RTE.	SECTION	COUNTY	TOTAL SHEETS	SHEET NO.
308	10HB,10WB,20R	ROCK ISLAND	210	52
STA. 1455+00.00 TO STA. 1485+00.00				
FED. ROAD DIST. NO. 2 ILLINOIS			FED. AID PROJECT	

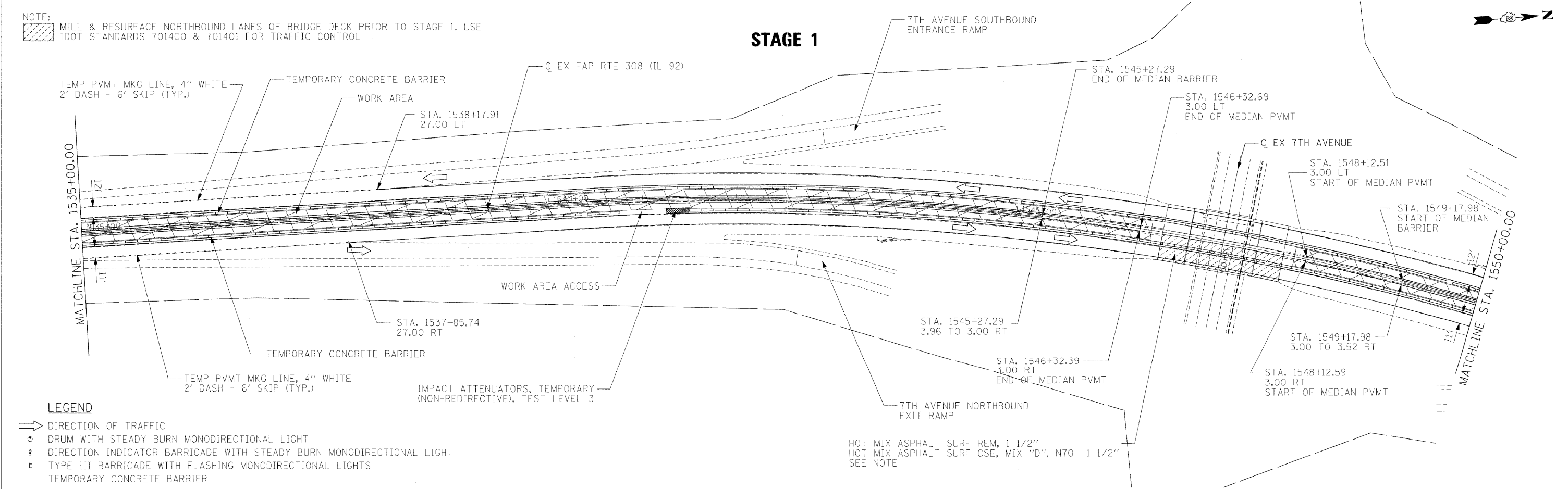

NOTE:
 MILL & RESURFACE NORTHBOUND LANES OF BRIDGE DECK PRIOR TO STAGE 1. USE IDOT STANDARDS 701400 & 701401 FOR TRAFFIC CONTROL



- LEGEND**
-  DIRECTION OF TRAFFIC
 -  DRUM WITH STEADY BURN MONODIRECTIONAL LIGHT
 -  DIRECTION INDICATOR BARRICADE WITH STEADY BURN MONODIRECTIONAL LIGHT
 -  TYPE III BARRICADE WITH FLASHING MONODIRECTIONAL LIGHTS
 -  TEMPORARY CONCRETE BARRIER

HOT MIX ASPHALT SURF REM. 1 1/2"
 HOT MIX ASPHALT SURF CSE, MIX "D", N70 1 1/2"
 SEE NOTE

PLOT DATE = 8/24/15
 FILE NAME = 011515
 USER NAME = RUSSEN

F.A.P. RTE.	SECTION	COUNTY	TOTAL SHEETS	SHEET NO.
308	11HB/HB-1,VB,HB-2IR	ROCK ISLAND	210	53
STA. 1455+00.00		TO STA. 1485+00.00		
FED. ROAD DIST. NO. 2		ILLINOIS FED. AID PROJECT		

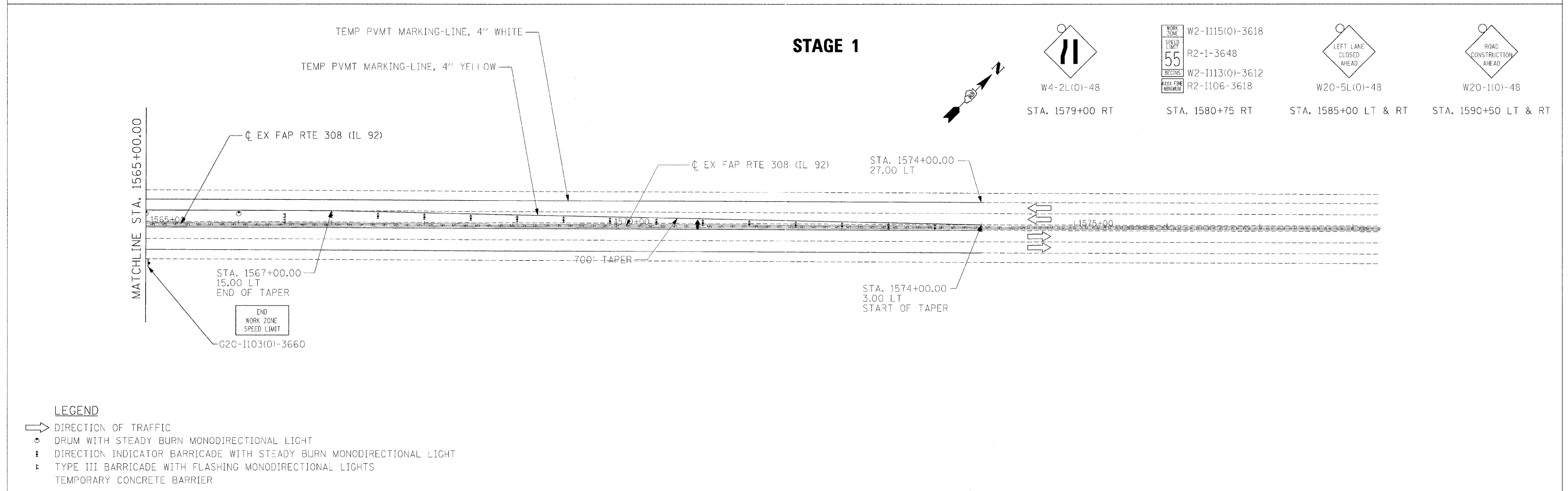
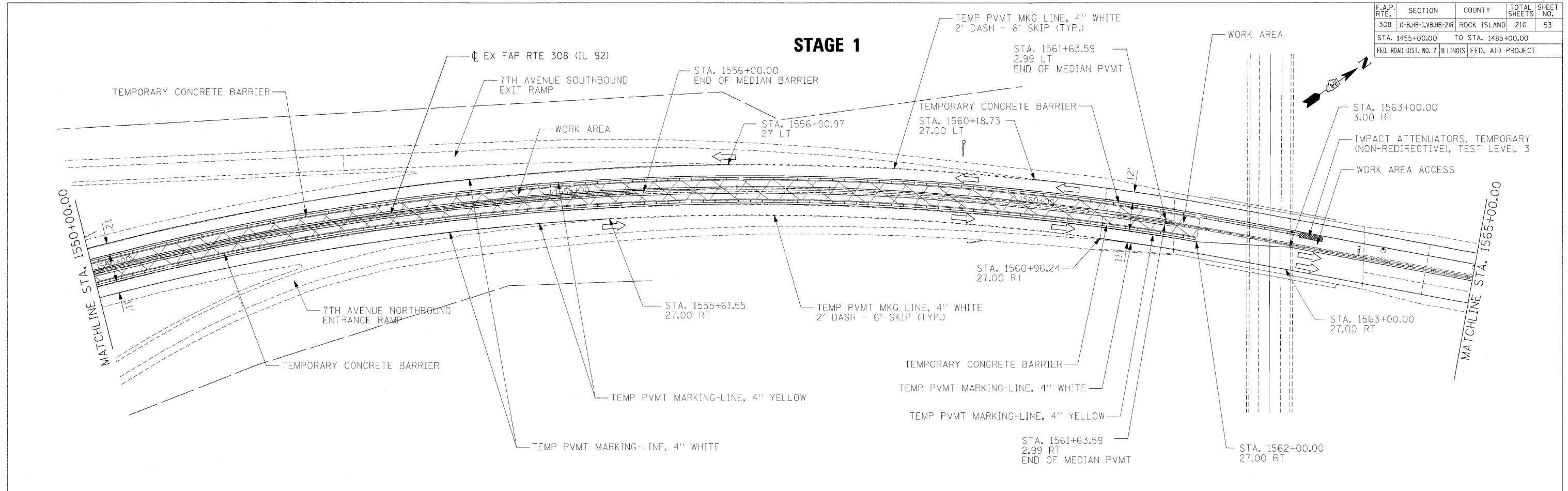

PLOT DATE = 08/15/18
 FILE NAME = 081518
 PLOT SCALE = 1/8"=1'-0"
 USER NAME = JWB/STW

- LEGEND**
- ➔ DIRECTION OF TRAFFIC
 - ⊙ DRUM WITH STEADY BURN MONODIRECTIONAL LIGHT
 - ⚡ DIRECTION INDICATOR BARRICADE WITH STEADY BURN MONODIRECTIONAL LIGHT
 - ⚡ TYPE III BARRICADE WITH FLASHING MONODIRECTIONAL LIGHTS
 - ▬ TEMPORARY CONCRETE BARRIER

F.A.P. RTE.	SECTION	COUNTY	TOTAL SHEETS	SHEET NO.
308	1 (NB, SB, WB, WB-2) R	ROCK ISLAND	210	54
STA. 1453+65.00		TO STA. 1460+35.00		
FED. ROAD DIST. NO. 2 ILLINOIS FED. AID PROJECT				

STAGE 2

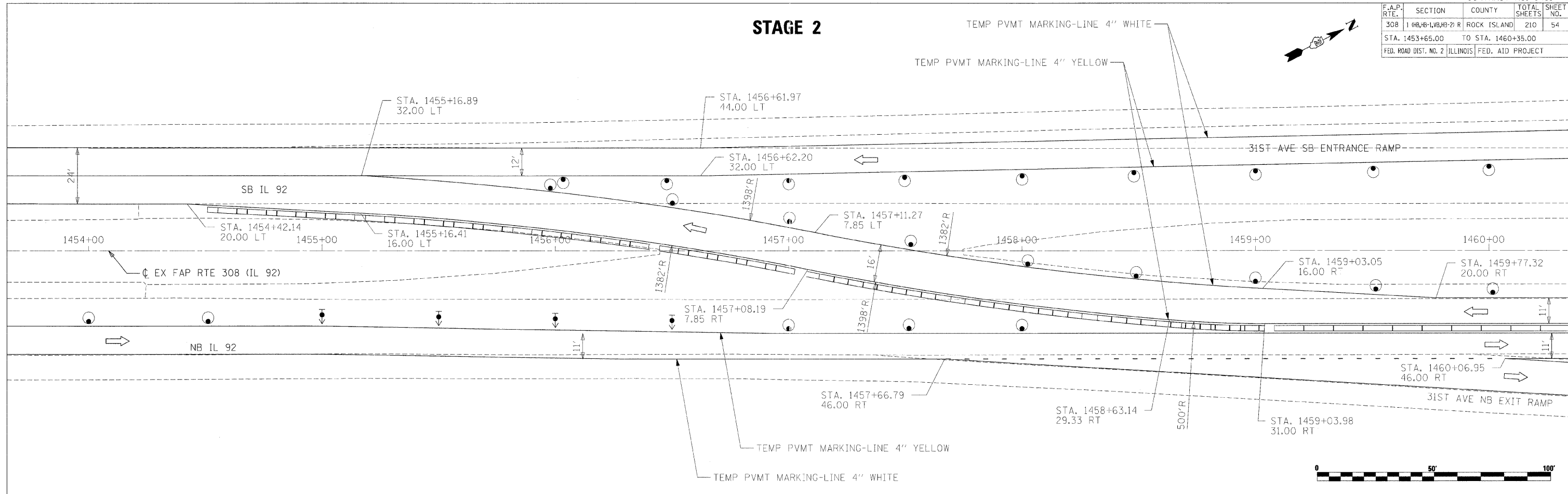

STAGE 2

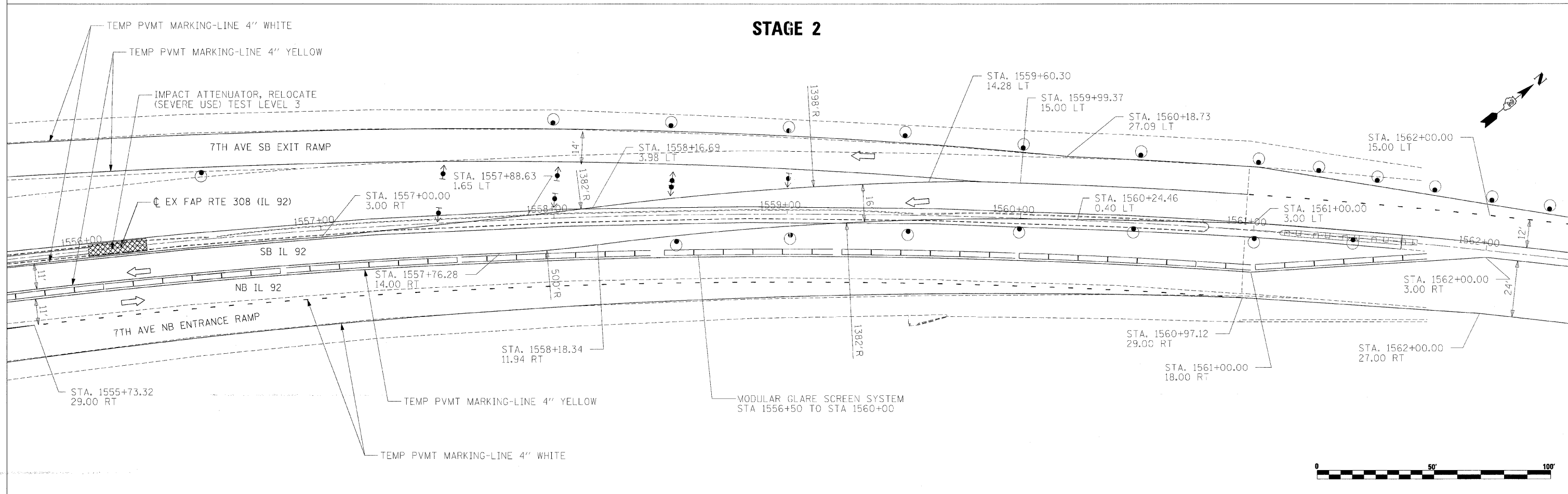

PLOT DATE = 8/21/05
 FILE NAME = 8/15/05
 USER NAME = ROBERT

F.A.P. RTE.	SECTION	COUNTY	TOTAL SHEETS	SHEET NO.
308	11HB,HB-1,VB,HB-2IR	ROCK ISLAND	210	54A
STA. 1430+00		TO STA. 1460+00		
FED. ROAD DIST. NO. 2		ILLINOIS	FED. AID PROJECT	

STAGE 2

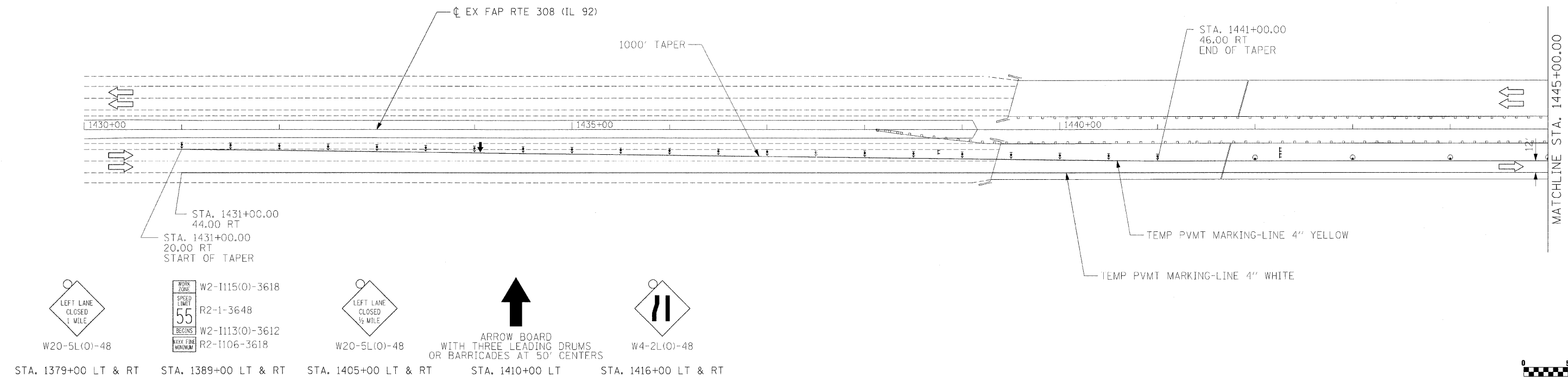
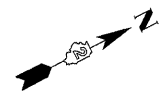

- W20-5L(0)-48
 STA. 1379+00 LT & RT
- W2-I115(0)-3618
 STA. 1389+00 LT & RT
- W20-5L(0)-48
 STA. 1405+00 LT & RT
- ARROW BOARD WITH THREE LEADING DRUMS OR BARRICADES AT 50' CENTERS
 STA. 1410+00 LT
- W4-2L(0)-48
 STA. 1416+00 LT & RT

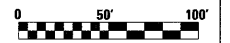

STAGE 2

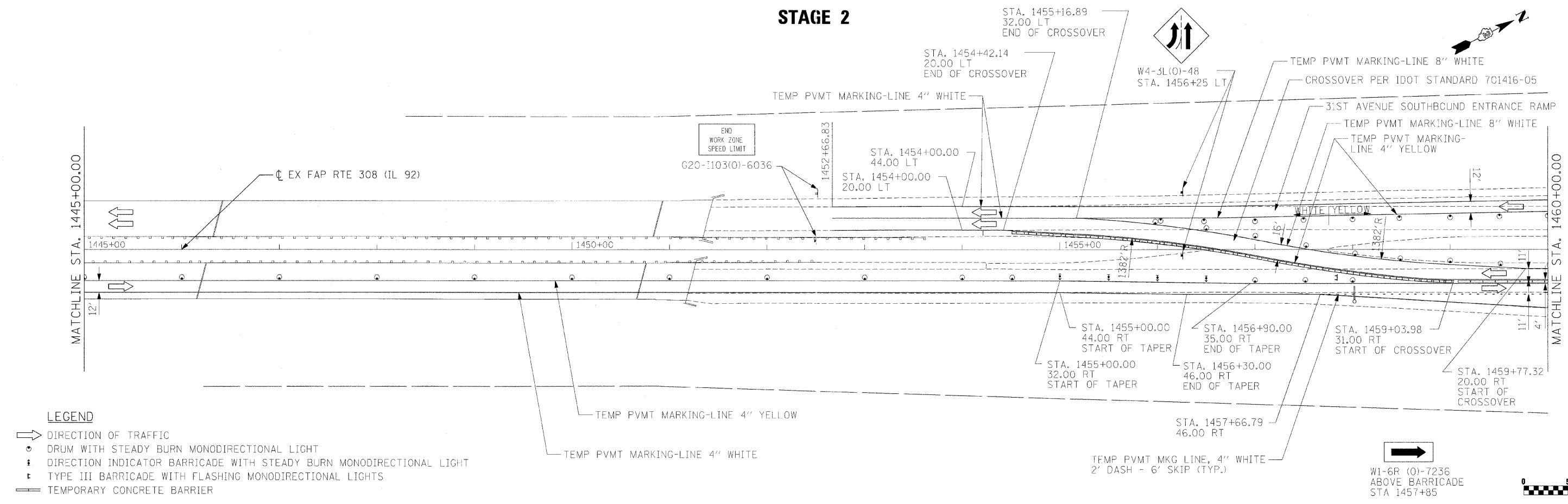
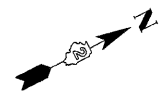

- LEGEND**
- DIRECTION OF TRAFFIC
 - DRUM WITH STEADY BURN MONODIRECTIONAL LIGHT
 - DIRECTION INDICATOR BARRICADE WITH STEADY BURN MONODIRECTIONAL LIGHT
 - TYPE III BARRICADE WITH FLASHING MONODIRECTIONAL LIGHTS
 - TEMPORARY CONCRETE BARRIER

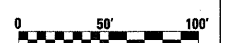

F.A.P. RTE.	SECTION	COUNTY	TOTAL SHEETS	SHEET NO.
308	118LJHB-1,VB,HB-2IR	ROCK ISLAND	210	55
STA. 1460+00 TO STA. 1490+00				
FED. ROAD DIST. NO. 2 ILLINOIS			FED. AID PROJECT	

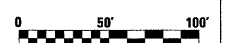
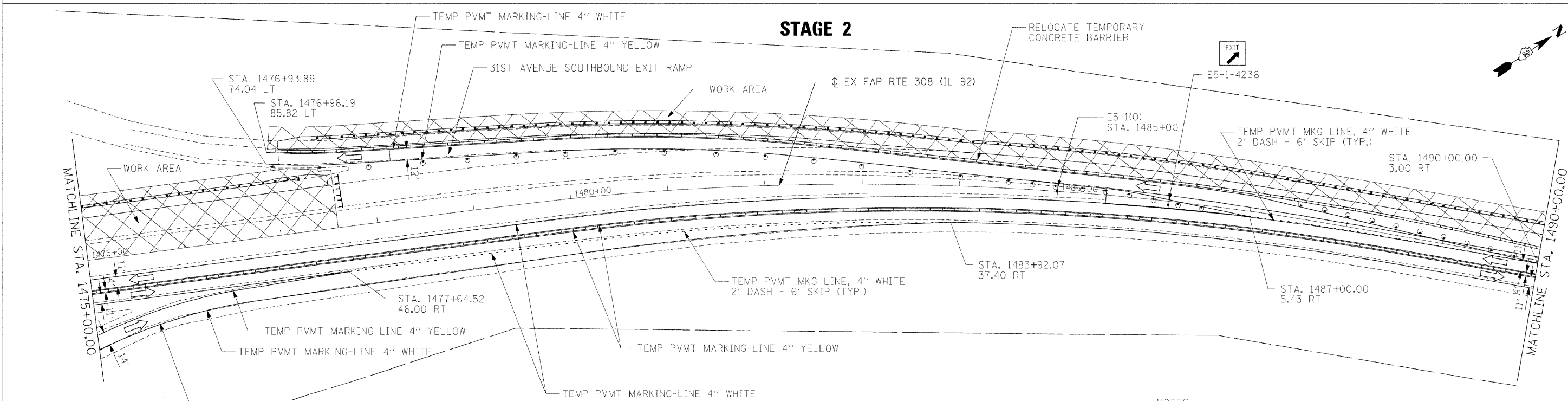
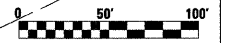
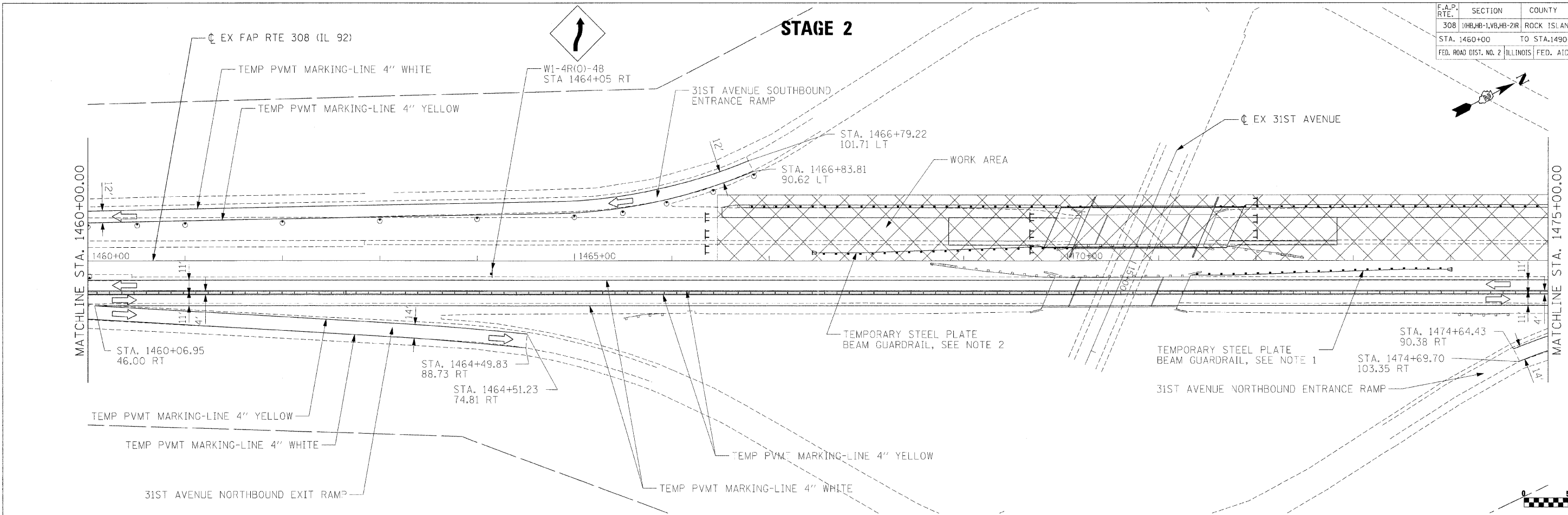

LEGEND

- DIRECTION OF TRAFFIC
- DRUM WITH STEADY BURN MONODIRECTIONAL LIGHT
- DIRECTION INDICATOR BARRICADE WITH STEADY BURN MONODIRECTIONAL LIGHT
- TYPE III BARRICADE WITH FLASHING MONODIRECTIONAL LIGHTS
- TEMPORARY CONCRETE BARRIER

- NOTES:**
- 262.5 FEET OF TEMPORARY STEEL PLATE BEAM GUARDRAIL, TYPE A WITH TEMPORARY TRAFFIC BARRIER TERMINAL, TYPE 1, SPECIAL AND TEMPORARY TRAFFIC BARRIER TERMINAL, TYPE 6A TO BE INSTALLED IN PHASE 1 AND REMOVED IN PHASE 3.
 - 262.5 FEET OF TEMPORARY STEEL PLATE BEAM GUARDRAIL, TYPE A WITH TEMPORARY TRAFFIC BARRIER TERMINAL, TYPE 1, SPECIAL AND TEMPORARY TRAFFIC BARRIER TERMINAL, TYPE 6 TO BE INSTALLED IN PHASE 2 AND REMOVED IN PHASE 4.

PLOT DATE = 8/24/15
 FILE NAME = 8/15/15
 PLOT SCALE = 1/8"=1'-0"
 USER NAME = RUSSELL

STAGE 2

CONTRACT NO.				
F.A. RTE.	SECTION	COUNTY	TOTAL SHEETS	SHEET NO.
308	18B, 18B-1, 18B-2R	ROCK ISLAND	210	56
STA. 1490+00		TO STA. 1520+00		
FED. ROAD DIST. NO. 2 ILLINOIS FED. AID PROJECT				

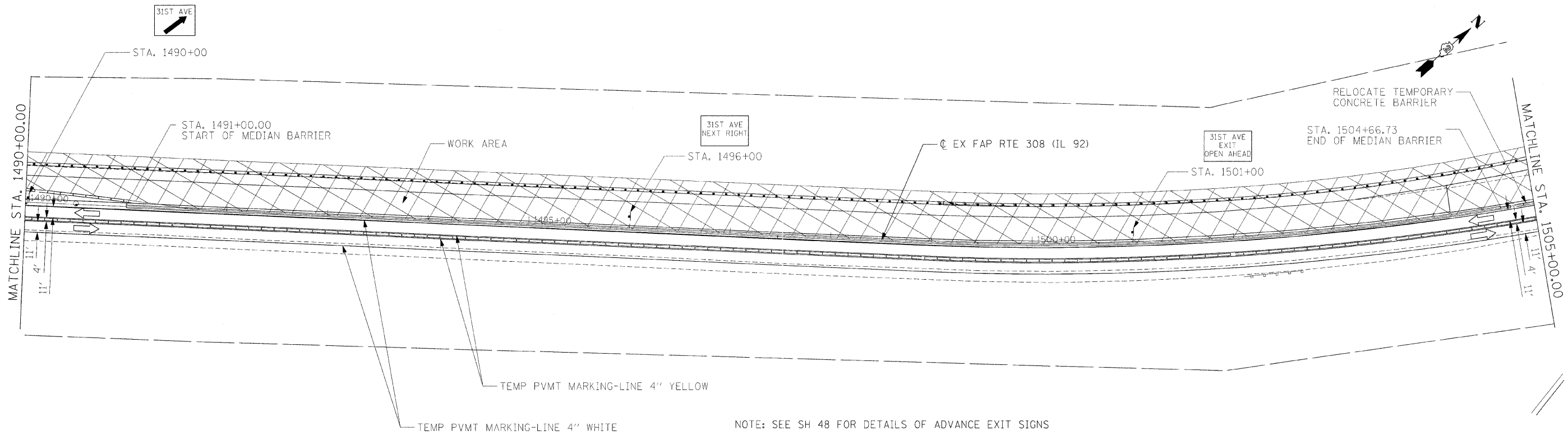

NOTE: SEE SH 48 FOR DETAILS OF ADVANCE EXIT SIGNS

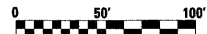

STAGE 2

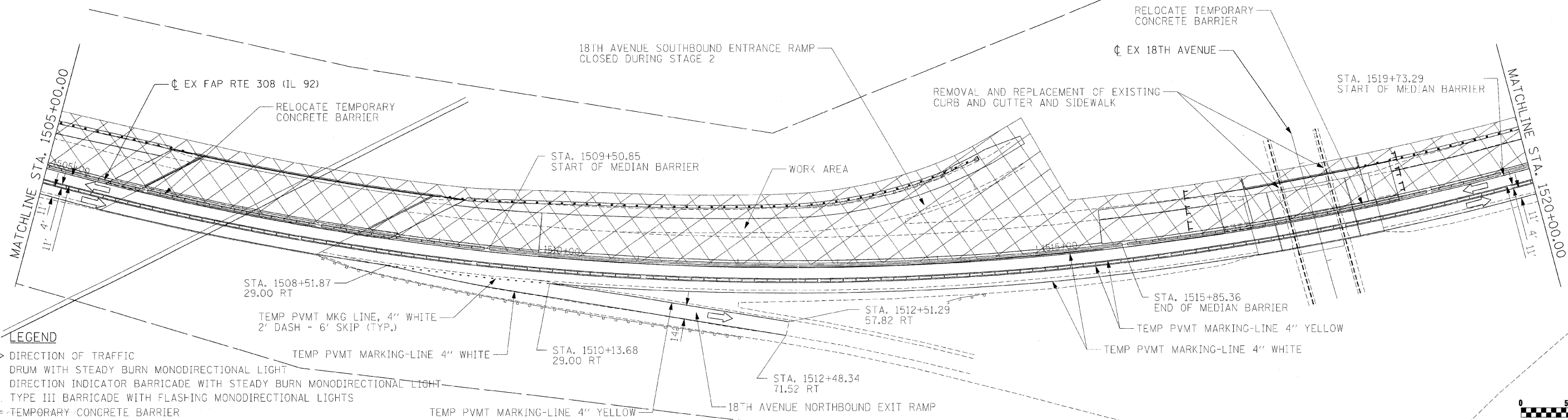

LEGEND

- DIRECTION OF TRAFFIC
- DRUM WITH STEADY BURN MONODIRECTIONAL LIGHT
- DIRECTION INDICATOR BARRICADE WITH STEADY BURN MONODIRECTIONAL LIGHT
- TYPE III BARRICADE WITH FLASHING MONODIRECTIONAL LIGHTS
- TEMPORARY CONCRETE BARRIER



PLOT DATE = 8/24/85
FILE NAME = 87LEL8
USER NAME = RUSSEN

F.A.P. RTE.	SECTION	COUNTY	TOTAL SHEETS	SHEET NO.
308	118B,1B-1,VB,1B-2,1R	ROCK ISLAND	210	57
STA. 1520+00		TO STA. 1550+00		
FED. ROAD DIST. NO. 2		ILLINOIS		FED. AID PROJECT

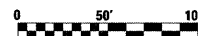
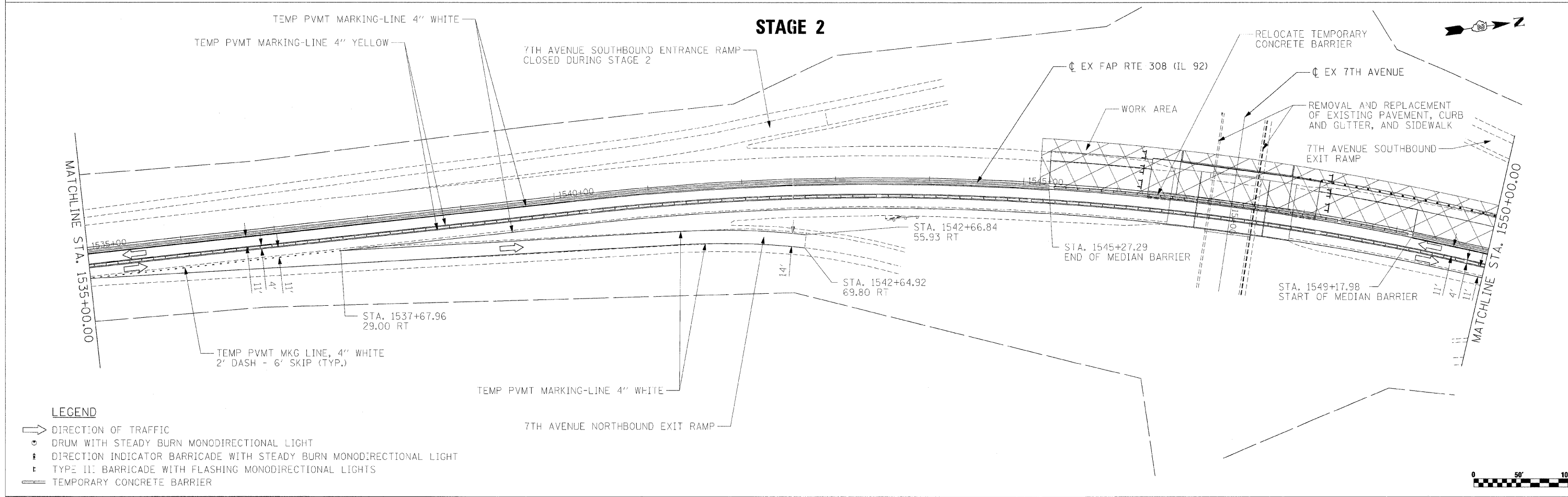
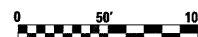
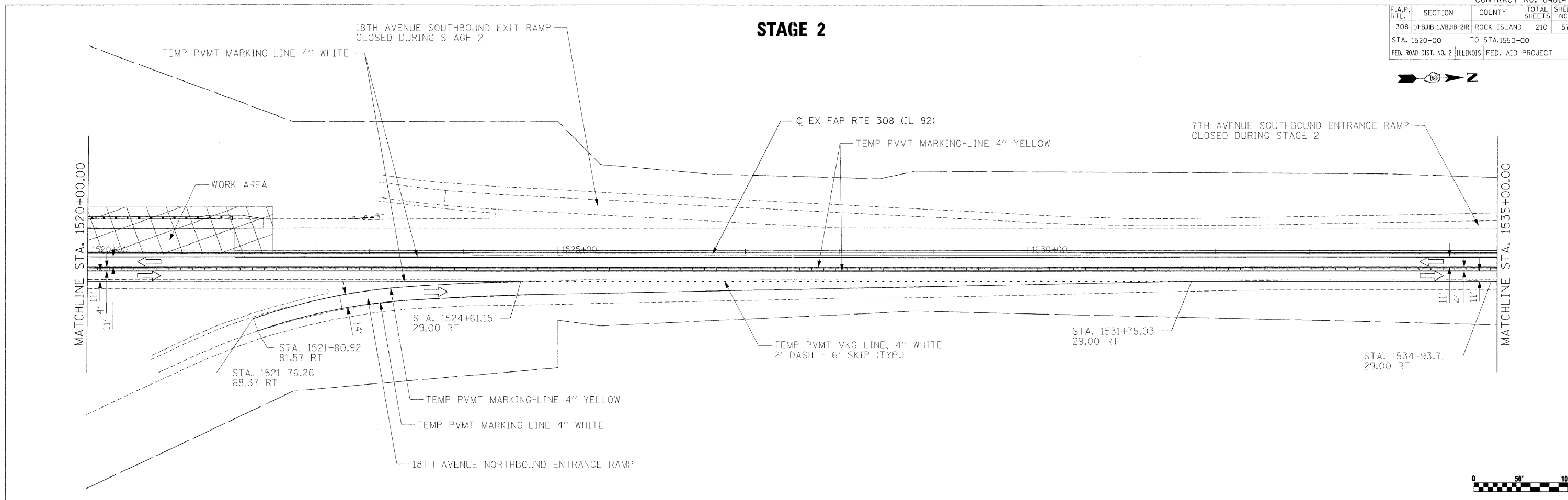

LEGEND

- DIRECTION OF TRAFFIC
- DRUM WITH STEADY BURN MONODIRECTIONAL LIGHT
- DIRECTION INDICATOR BARRICADE WITH STEADY BURN MONODIRECTIONAL LIGHT
- TYPE III BARRICADE WITH FLASHING MONODIRECTIONAL LIGHTS
- TEMPORARY CONCRETE BARRIER

PLOT DATE = 8/24/85
 FILE NAME = 8/FILEL8
 PLOT SCALE = 1/8"=1'-0"
 USER NAME = J483616

F.A. RTE.	SECTION	COUNTY	TOTAL SHEETS	SHEET NO.
308	10B,10B-1,10B,10B-2,10B	ROCK ISLAND	210	58
STA. 1550+00		TO STA. 1580+00		
FED. ROAD DIST. NO. 2		ILLINOIS	FED. AID PROJECT	

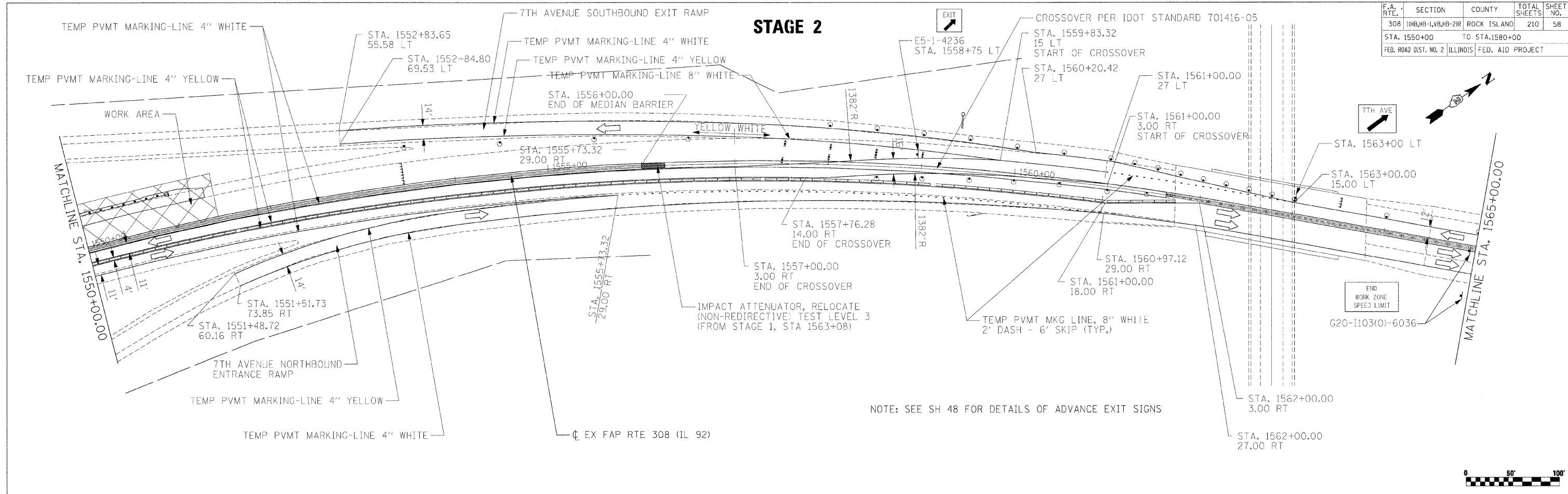

NOTE: SEE SH 48 FOR DETAILS OF ADVANCE EXIT SIGNS

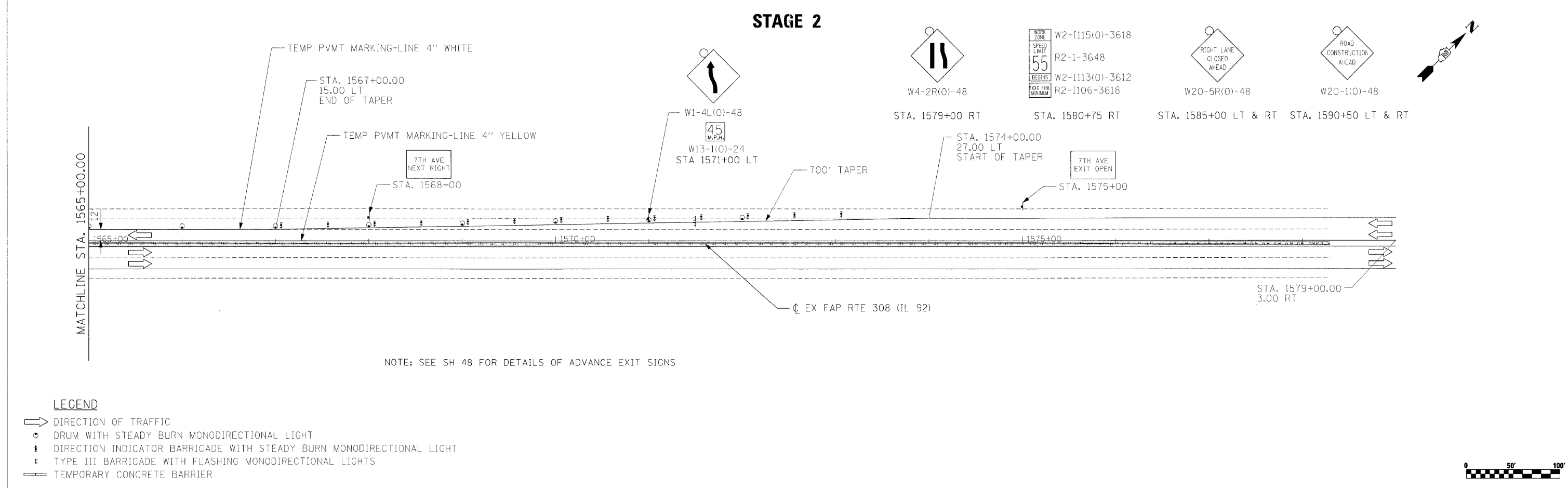
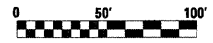

NOTE: SEE SH 48 FOR DETAILS OF ADVANCE EXIT SIGNS

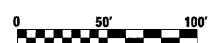

LEGEND

- DIRECTION OF TRAFFIC
- DRUM WITH STEADY BURN MONODIRECTIONAL LIGHT
- DIRECTION INDICATOR BARRICADE WITH STEADY BURN MONODIRECTIONAL LIGHT
- TYPE III BARRICADE WITH FLASHING MONODIRECTIONAL LIGHTS
- TEMPORARY CONCRETE BARRIER

PLOT DATE = 08/15/15
 FILE NAME = ST1550-1580-00
 PLOT SCALE = 1/8\"/>

F.A.P. RTE.	SECTION	COUNTY	TOTAL SHEETS	SHEET NO.
308	1 00B/1B-1/2B/2-1 R	ROCK ISLAND	210	59
STA. 1555+65.00 TO STA. 1562+35.00				
FED. ROAD DIST. NO. 2 ILLINOIS FED. AID PROJECT				

STAGE 3

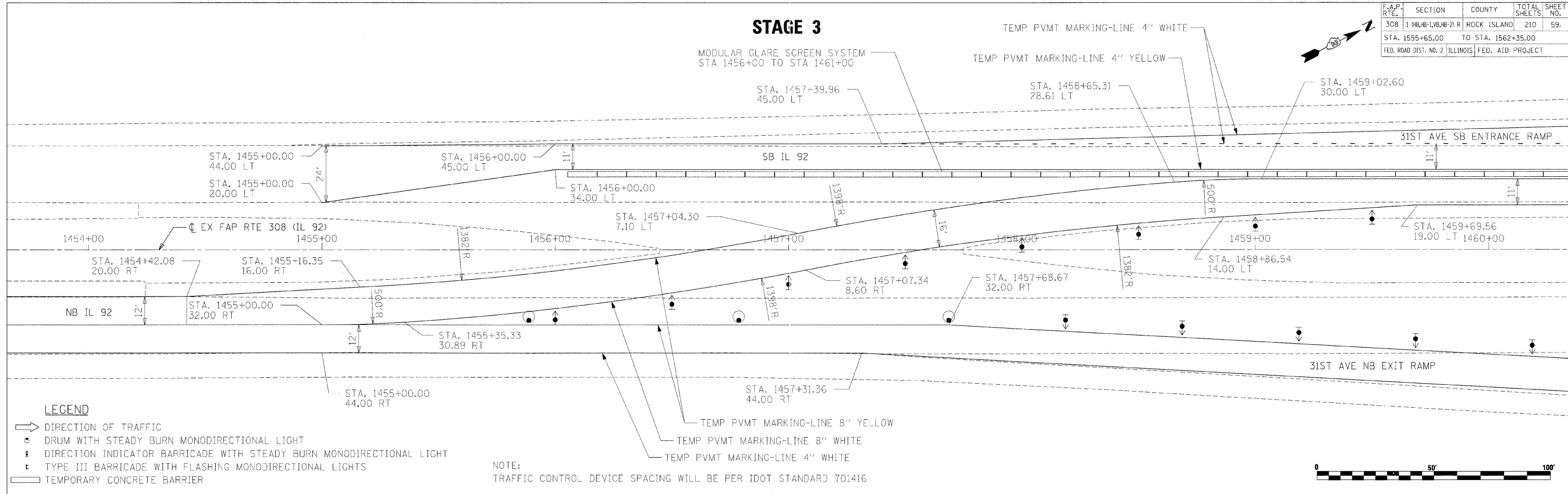

STAGE 3

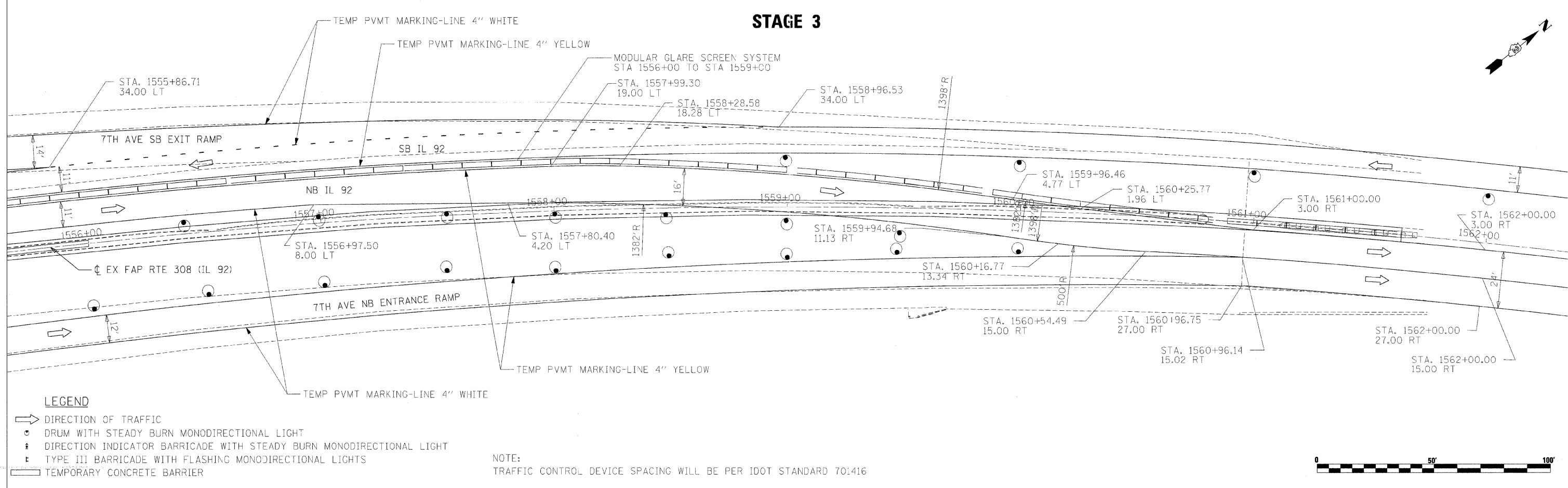

PLOT DATE = 8/24/15
 FILE NAME = 8/15/15
 USER NAME = RUSSELL

F.A.P. RTE.	SECTION	COUNTY	TOTAL SHEETS	SHEET NO.
308	11-HB,1B-1,VB,1B-2H	ROCK ISLAND	210	59A
STA. 1430+00.00		TO STA. 1460+00.00		
FED. ROAD DIST. NO. 2		ILLINOIS FED. AID PROJECT		

STAGE 3

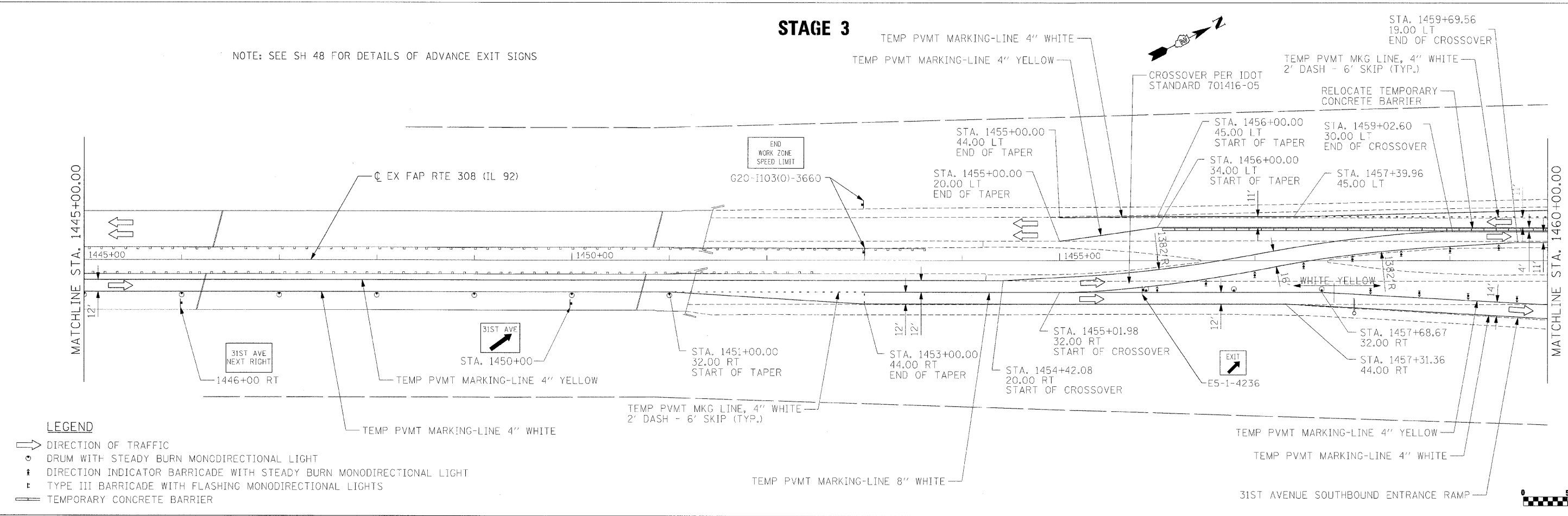
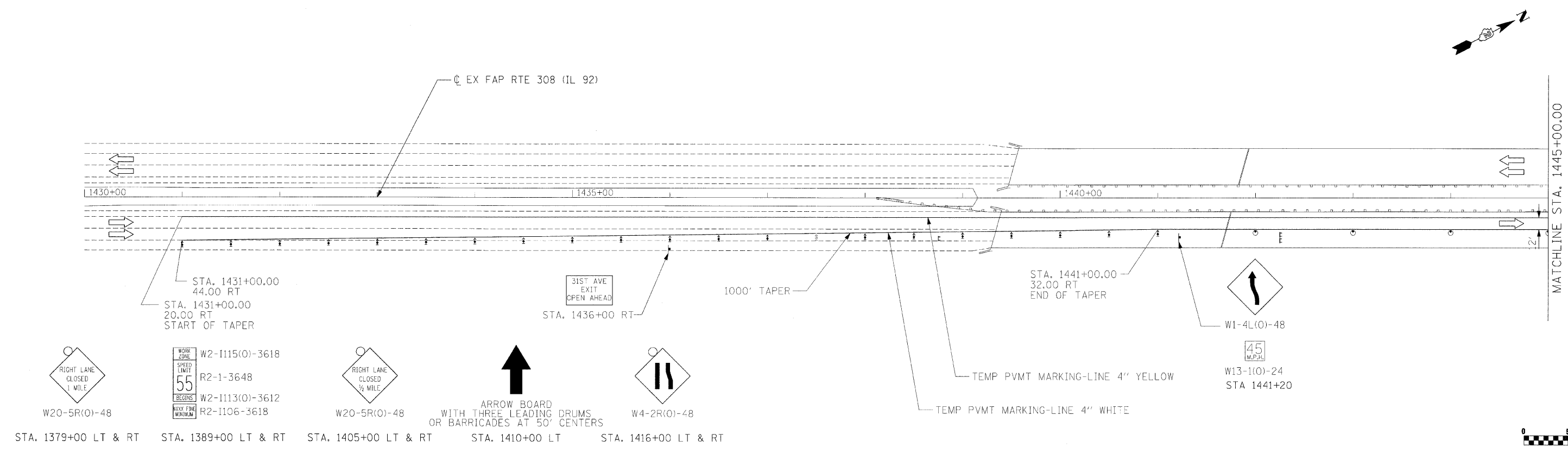

LEGEND

- ➔ DIRECTION OF TRAFFIC
- DRUM WITH STEADY BURN MONODIRECTIONAL LIGHT
- ➔ DIRECTION INDICATOR BARRICADE WITH STEADY BURN MONODIRECTIONAL LIGHT
- ⚡ TYPE III BARRICADE WITH FLASHING MONODIRECTIONAL LIGHTS
- ▬ TEMPORARY CONCRETE BARRIER

PLOT DATE = 8/24/05
 FILE NAME = 05FILE3
 PLOT SCALE = 1/8\"/>

F.A.P. RTE.	SECTION	COUNTY	TOTAL SHEETS	SHEET NO.
308	IIB,IB-1,VB,IB-2R	ROCK ISLAND	210	60
STA. 1460+00.00 TO STA. 1490+00.00				
FED. ROAD DIST. NO. 2 ILLINOIS		FED. AID PROJECT		

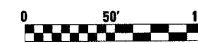
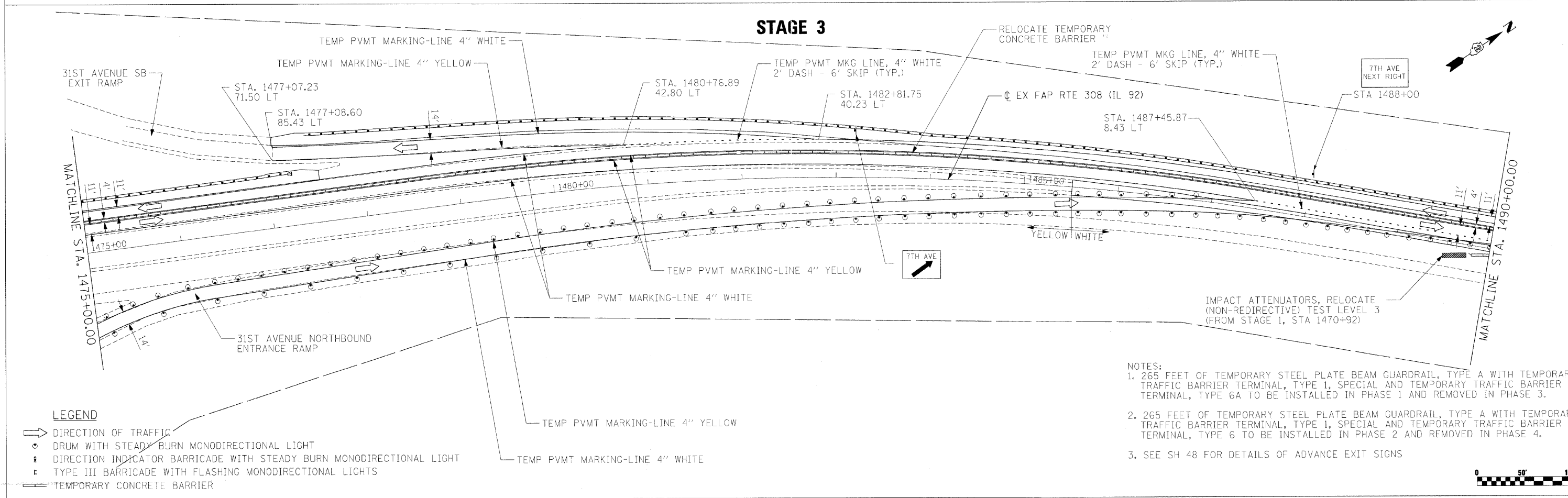
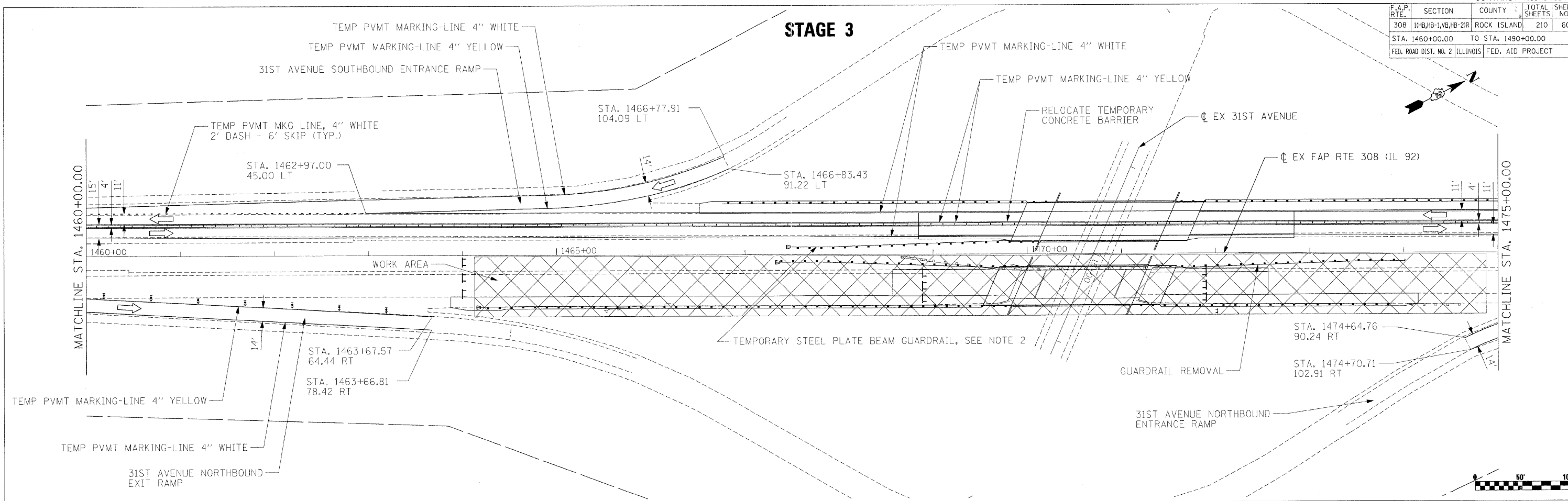

F.A.P. RTE.	SECTION	COUNTY	TOTAL SHEETS	SHEET NO.
308	148B,148C,148D,148E,148F,148G,148H,148I,148J,148K,148L,148M,148N,148O,148P,148Q,148R,148S,148T,148U,148V,148W,148X,148Y,148Z	ROCK ISLAND	210	61
STA. 1490+00.00 TO STA. 1520+00.00				
FED. ROAD DIST. NO. 2 ILLINOIS FED. AID PROJECT				

STAGE 3

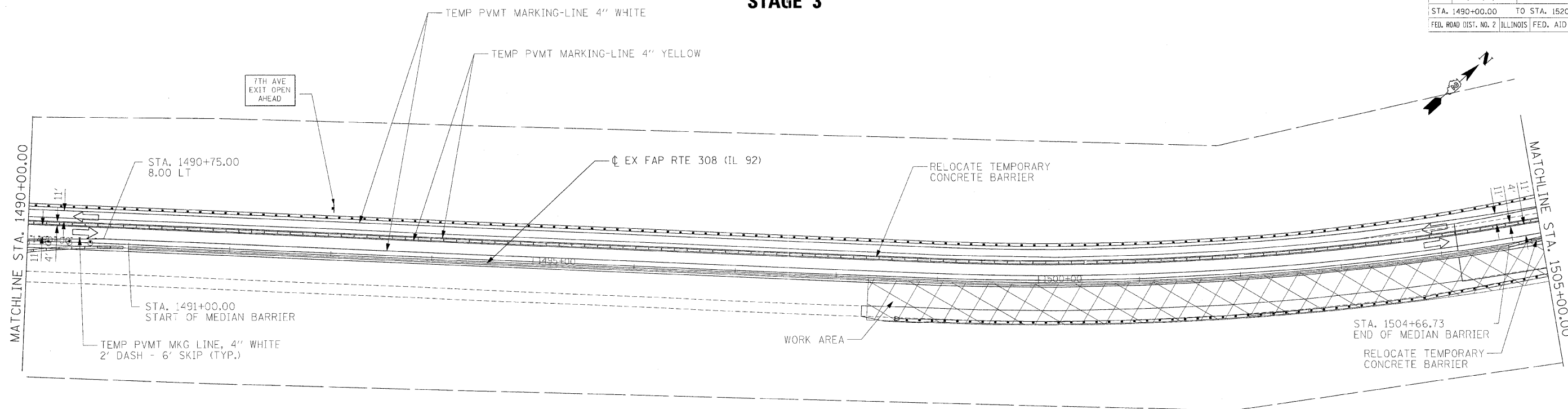

NOTE: SEE SH 48 FOR DETAILS OF ADVANCE EXIT SIGNS

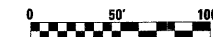

STAGE 3

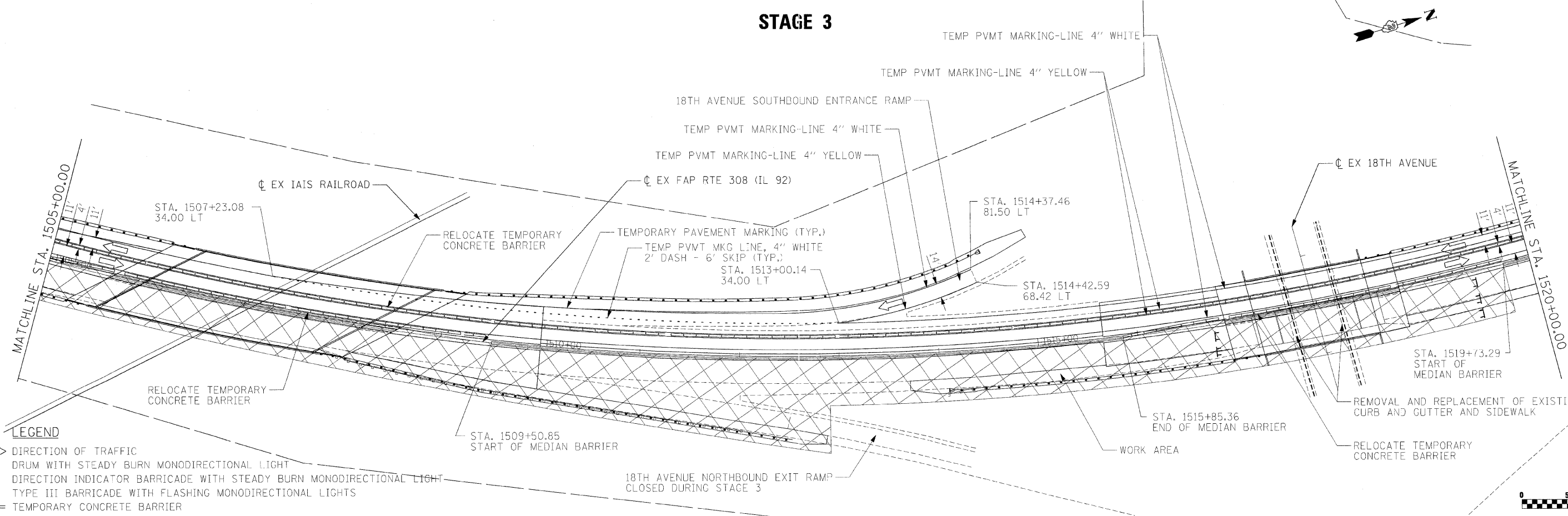

LEGEND

- DIRECTION OF TRAFFIC
- DRUM WITH STEADY BURN MONODIRECTIONAL LIGHT
- DIRECTION INDICATOR BARRICADE WITH STEADY BURN MONODIRECTIONAL LIGHT
- TYPE III BARRICADE WITH FLASHING MONODIRECTIONAL LIGHTS
- TEMPORARY CONCRETE BARRIER



PLOT DATE = 08/15/05
 FILE NAME = 081505
 PLOT SCALE = 1/8"=1'-0"
 USER NAME = JROBERT

F.A.P. RTE.	SECTION	COUNTY	TOTAL SHEETS	SHEET NO.
308	118B,118C,118D,118E,118F,118G,118H,118I,118J,118K,118L,118M,118N,118O,118P,118Q,118R,118S,118T,118U,118V,118W,118X,118Y,118Z	ROCK ISLAND	210	62
STA. 1520+00.00 TO STA. 1550+00.00				
FED. ROAD DIST. NO. 2 ILLINOIS FED. AID PROJECT				

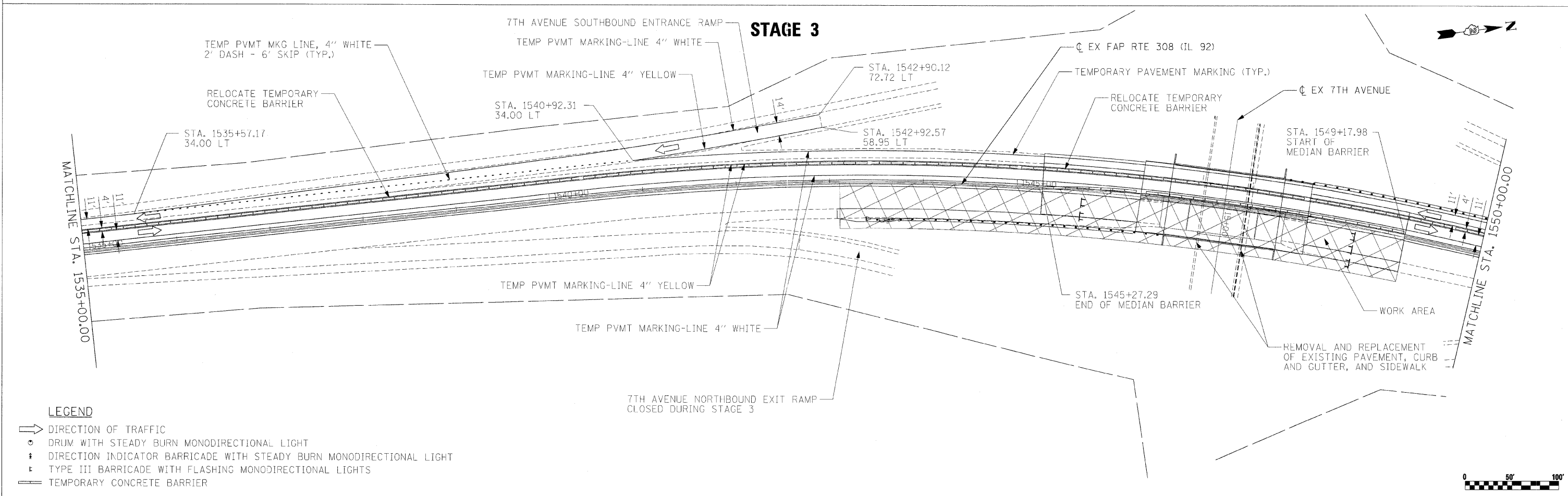
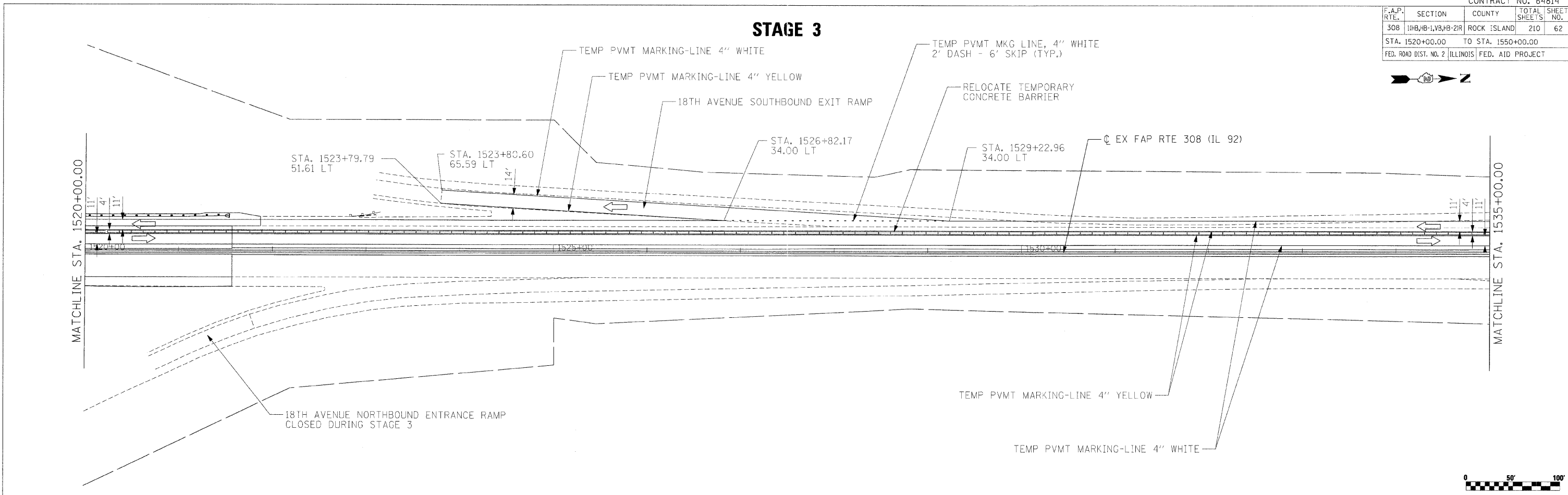
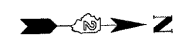

LEGEND

- DIRECTION OF TRAFFIC
- DRUM WITH STEADY BURN MONODIRECTIONAL LIGHT
- DIRECTION INDICATOR BARRICADE WITH STEADY BURN MONODIRECTIONAL LIGHT
- TYPE III BARRICADE WITH FLASHING MONODIRECTIONAL LIGHTS
- TEMPORARY CONCRETE BARRIER

PLOT DATE = 8/24/85
 FILE NAME = 871111.D
 USER NAME = RUSSELL
 USER NAME = RUSSELL

F.A.P. RTE.	SECTION	COUNTY	TOTAL SHEETS	SHEET NO.
308	10B,10B-1,10B,10B-2R	ROCK ISLAND	210	63
STA. 1550+00.00 TO STA. 1580+00.00				
FED. ROAD DIST. NO. 2 ILLINOIS FED. AID PROJECT				

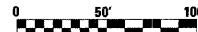
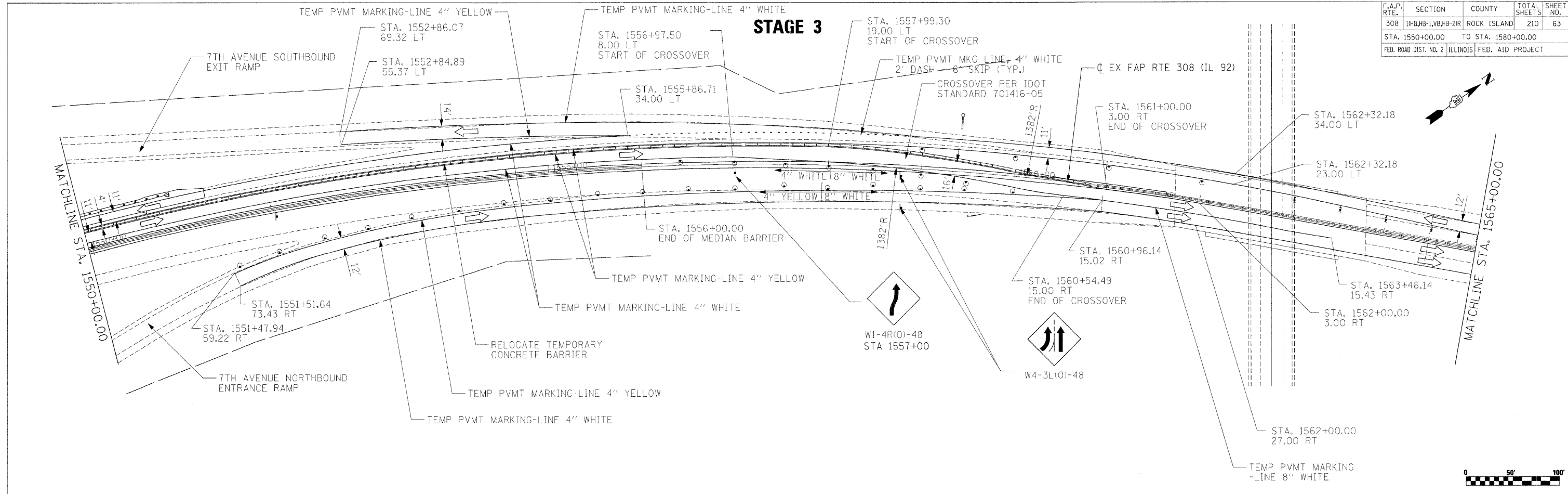

STAGE 3

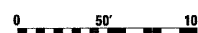
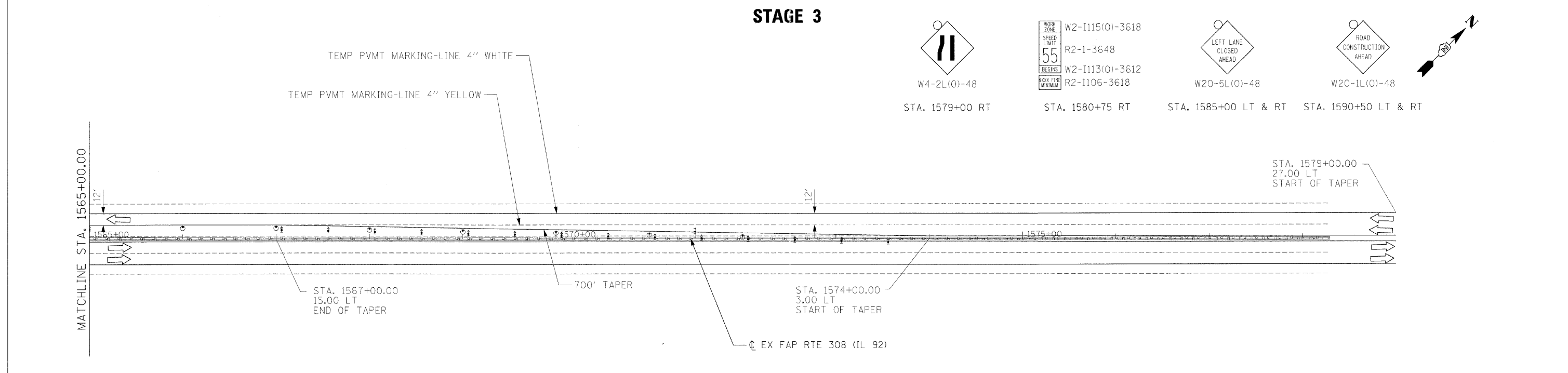

LEGEND

- DIRECTION OF TRAFFIC
- DRUM WITH STEADY BURN MONODIRECTIONAL LIGHT
- DIRECTION INDICATOR BARRICADE WITH STEADY BURN MONODIRECTIONAL LIGHT
- TYPE III BARRICADE WITH FLASHING MONODIRECTIONAL LIGHTS
- TEMPORARY CONCRETE BARRIER

PLOT DATE = 08/20/15
 FILE NAME = 8FLEL8
 PLOT SCALE = 1/8"=1'-0"
 USER NAME = JUDITH

F.A.P. RTE.	SECTION	COUNTY	TOTAL SHEETS	SHEET NO.
308	111B,1B-1,VB,1B-21R	ROCK ISLAND	210	64
STA. 1455+00.00		TO STA. 1485+00.00		
FED. ROAD DIST. NO. 2		ILLINOIS	FED. AID PROJECT	

STAGE 4

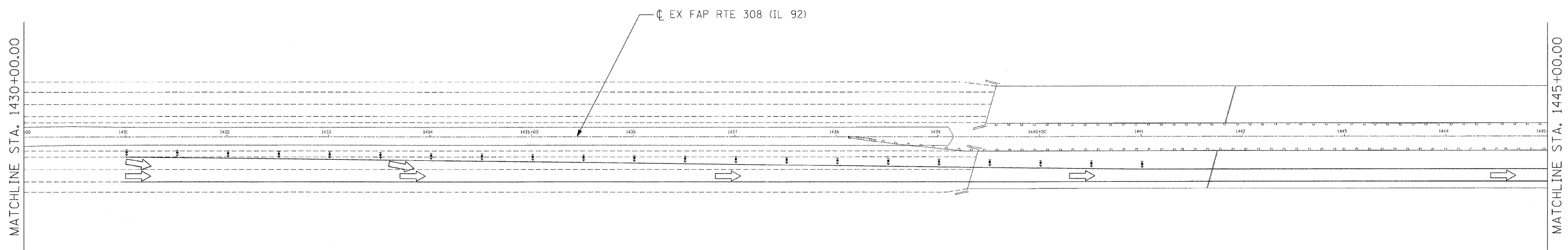
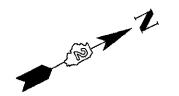

W20-5L(O)-48

STA. 1379+00 LT & RT

WORK ZONE
SPEED LIMIT
55
BEGINS
W2-1115(O)-3618
R2-1-3648
W2-1113(O)-3612
R2-1106-3618

STA. 1389+00 LT & RT



W20-5L(O)-48

STA. 1405+00 LT & RT



ARROW BOARD
WITH THREE LEADING DRUMS
OR BARRICADES AT 50' CENTERS

STA. 1410+00 LT

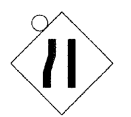

W4-2L(O)-48

STA. 1416+00 LT & RT

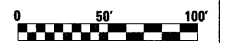

STAGE 4

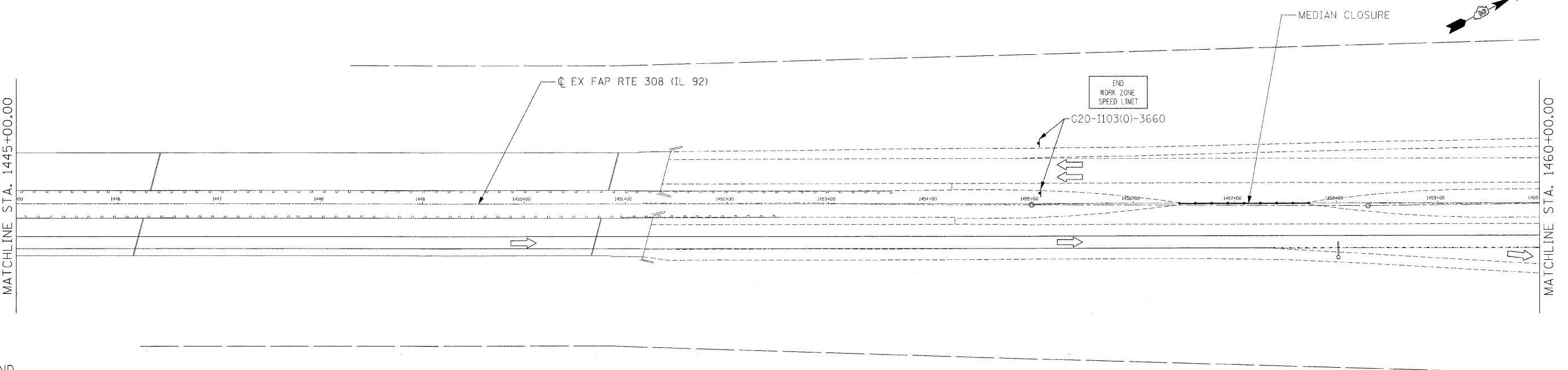
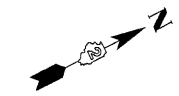

- LEGEND**
- DIRECTION OF TRAFFIC
 - DRUM WITH STEADY BURN MONODIRECTIONAL LIGHT
 - DIRECTION INDICATOR BARRICADE WITH STEADY BURN MONODIRECTIONAL LIGHT
 - TYPE III BARRICADE WITH FLASHING MONODIRECTIONAL LIGHTS
 - TEMPORARY CONCRETE BARRIER

PLOT DATE = 8/24/15
FILE NAME = #FILE#
PLOT SCALE = #SCALE#
USER NAME = #USER#

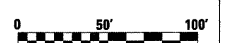

F.A.P. RTE.	SECTION	COUNTY	TOTAL SHEETS	SHEET NO.
308	11H6JH-1,V3,H3-2R	ROCK ISLAND	210	65
STA. 1485+00.00		TO STA. 1515+00.00		
FED. ROAD DIST. NO. 2		ILLINOIS	FED. AID PROJECT	

STAGE 4

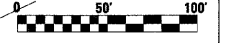
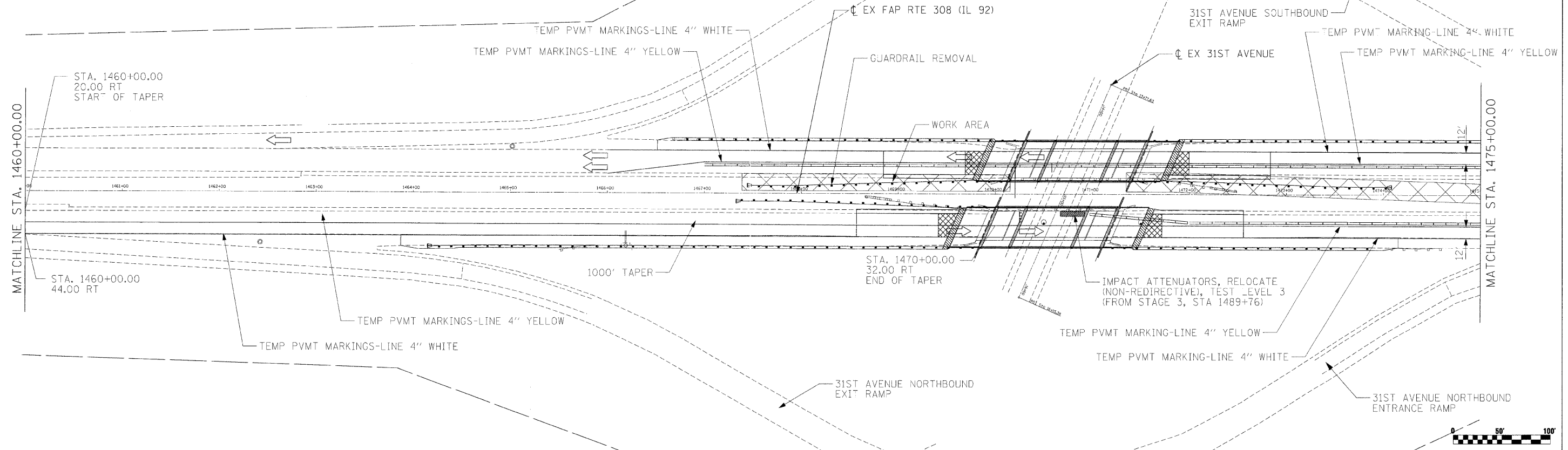

STAGE 4

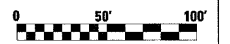
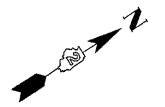
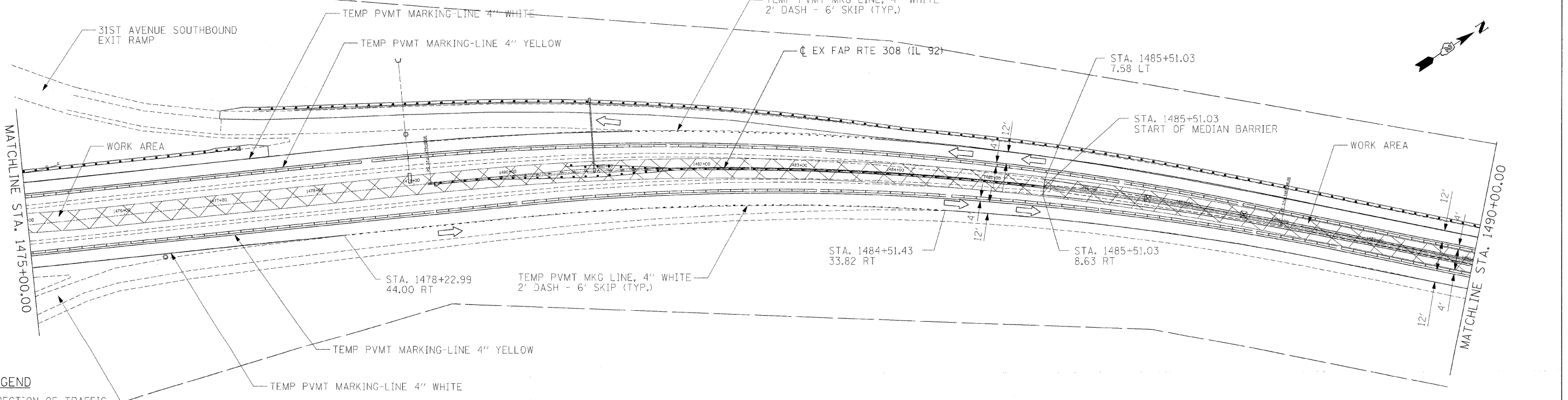

LEGEND

- DIRECTION OF TRAFFIC
- DRUM WITH STEADY BURN MONODIRECTIONAL LIGHT
- DIRECTION INDICATOR BARRICADE WITH STEADY BURN MONODIRECTIONAL LIGHT
- TYPE III BARRICADE WITH FLASHING MONODIRECTIONAL LIGHTS
- TEMPORARY CONCRETE BARRIER

PLOT DATE = 04/15/08
 FILE NAME = 041508
 PLOT SCALE = 1/8"=1'-0"
 USER NAME = 08/08/08

F.A.P. RTE.	SECTION	COUNTY	TOTAL SHEETS	SHEET NO.
308	14B,14B-1,14B,14B-2R	ROCK ISLAND	210	66
STA. 1515+00.00		TO STA. 1545+00.00		
FED. ROAD DIST. NO. 2 ILLINOIS FED. AID PROJECT				

STAGE 4

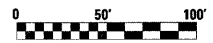
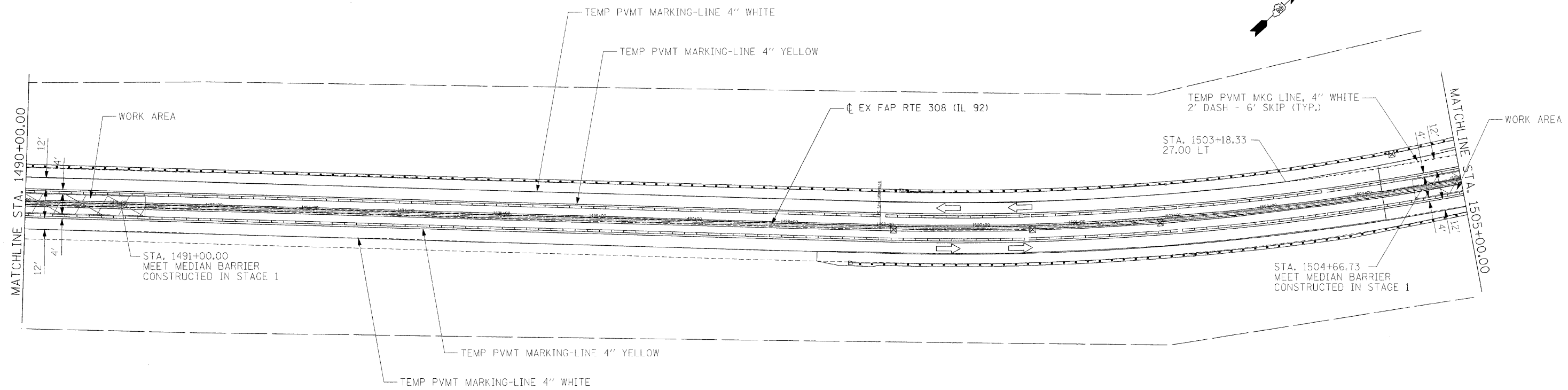

STAGE 4

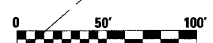
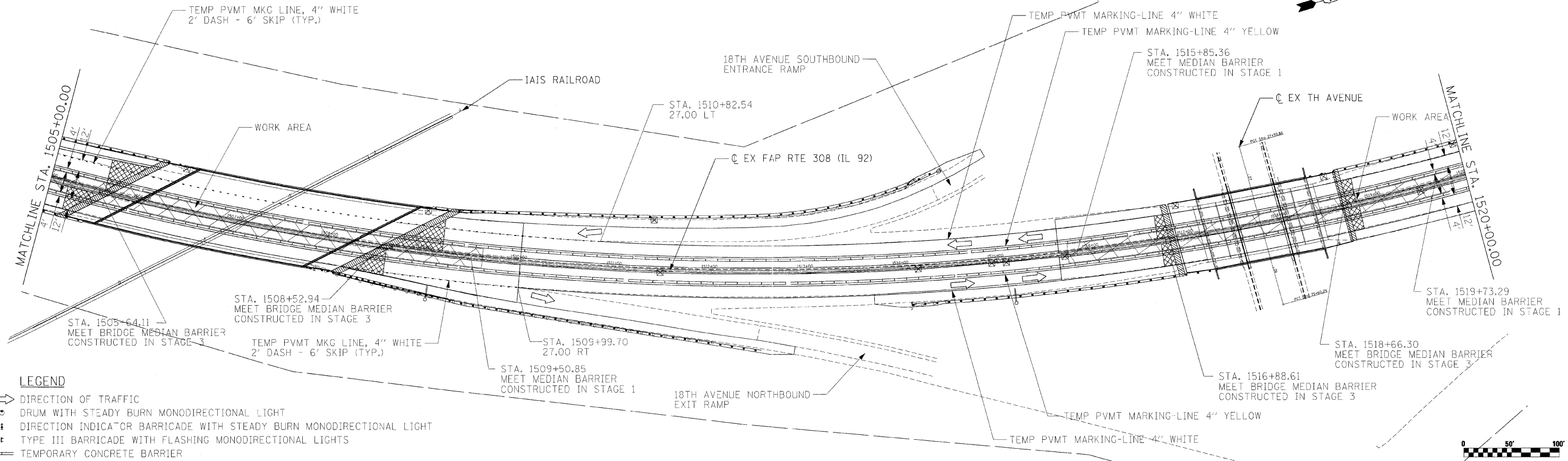

LEGEND

- DIRECTION OF TRAFFIC
- DRUM WITH STEADY BURN MONODIRECTIONAL LIGHT
- DIRECTION INDICATOR BARRICADE WITH STEADY BURN MONODIRECTIONAL LIGHT
- TYPE III BARRICADE WITH FLASHING MONODIRECTIONAL LIGHTS
- TEMPORARY CONCRETE BARRIER

PLOT DATE = 08/20/05
 FILE NAME = 8115L3
 PLOT SCALE = 1/8"=1'-0"
 USER NAME = R020505

F.A.P. RTE.	SECTION	COUNTY	TOTAL SHEETS	SHEET NO.
308	11HB,HB-1,VB,HB-2R	ROCK ISLAND	210	67
STA. 1545+00.00		TO STA. 1575+00.00		
FED. ROAD DIST. NO. 2		ILLINOIS		FED. AID PROJECT

STAGE 4

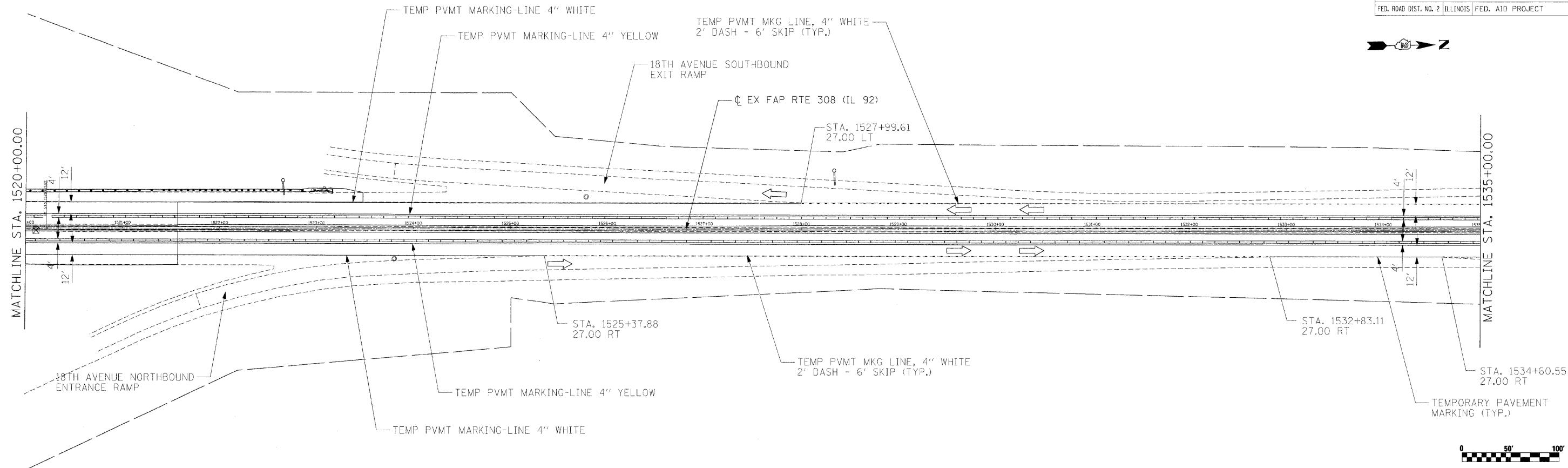

STAGE 4

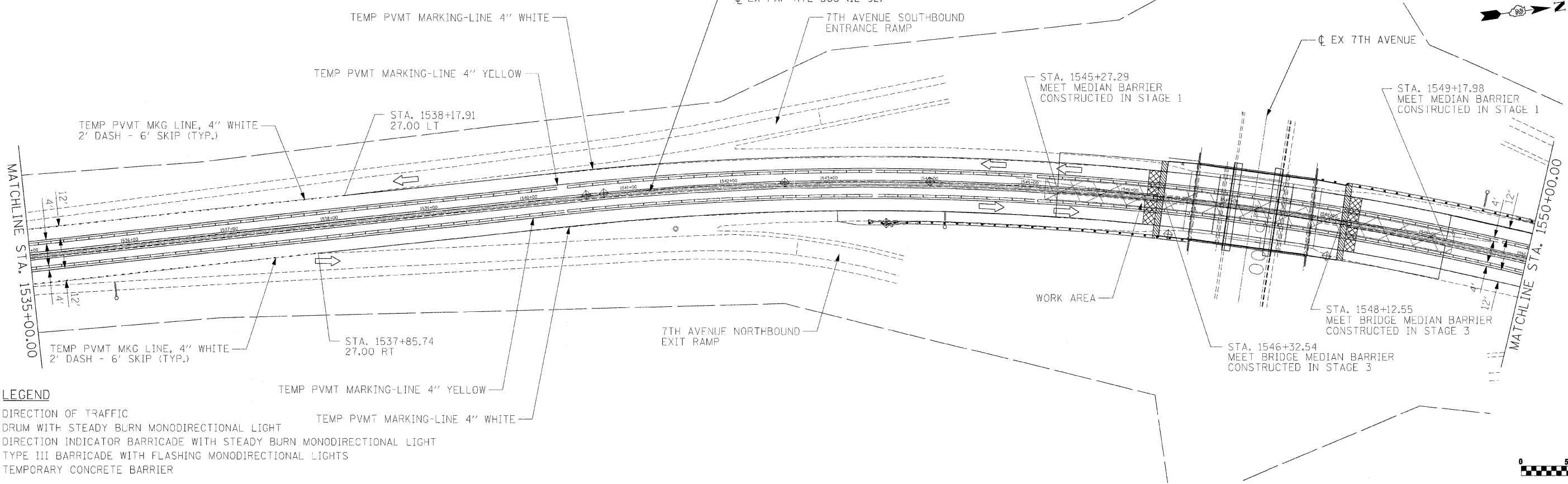

LEGEND

- DIRECTION OF TRAFFIC
- DRUM WITH STEADY BURN MONODIRECTIONAL LIGHT
- DIRECTION INDICATOR BARRICADE WITH STEADY BURN MONODIRECTIONAL LIGHT
- TYPE III BARRICADE WITH FLASHING MONODIRECTIONAL LIGHTS
- TEMPORARY CONCRETE BARRIER

PLOT DATE = 8/24/15
 FILE NAME = 8/15/15
 PLOT SCALE = 1/8"=1'-0"
 USER NAME = JROBERTS

F.A.P. RTE.	SECTION	COUNTY	TOTAL SHEETS	SHEET NO.
308	104B,104B-1,104B-2,104B-3	ROCK ISLAND	210	67A
STA. 1545+00.00 TO STA. 1575+00.00				
FED. ROAD DIST. NO. 2 ILLINOIS		FED. AID PROJECT		

STAGE 4

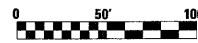
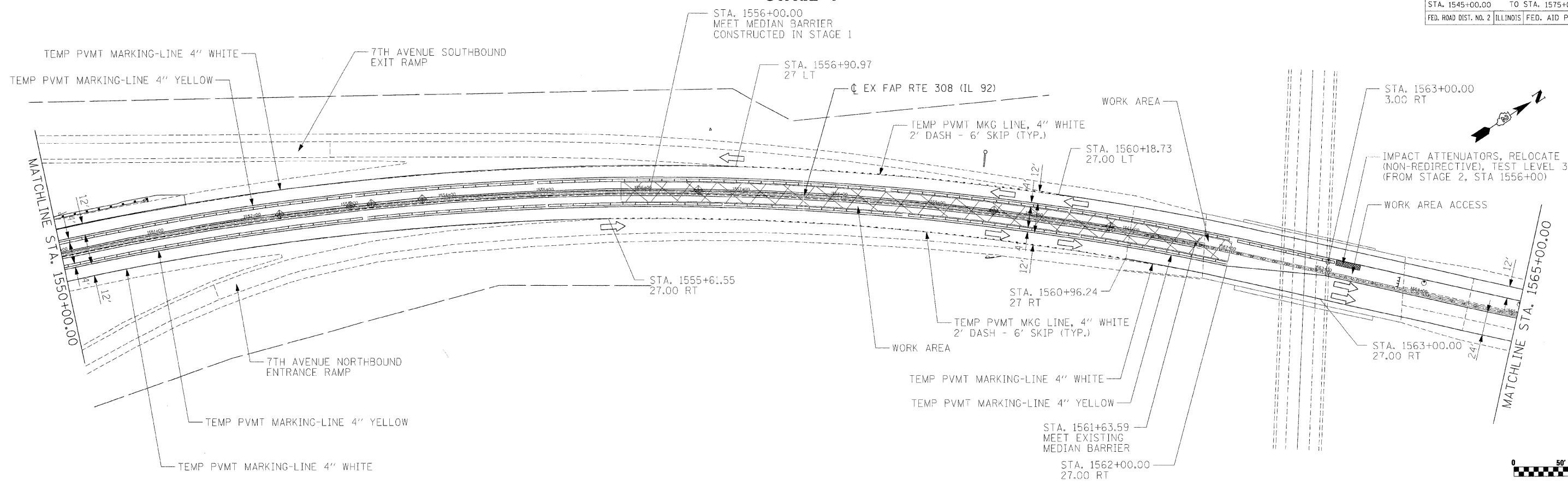

STAGE 4

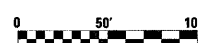
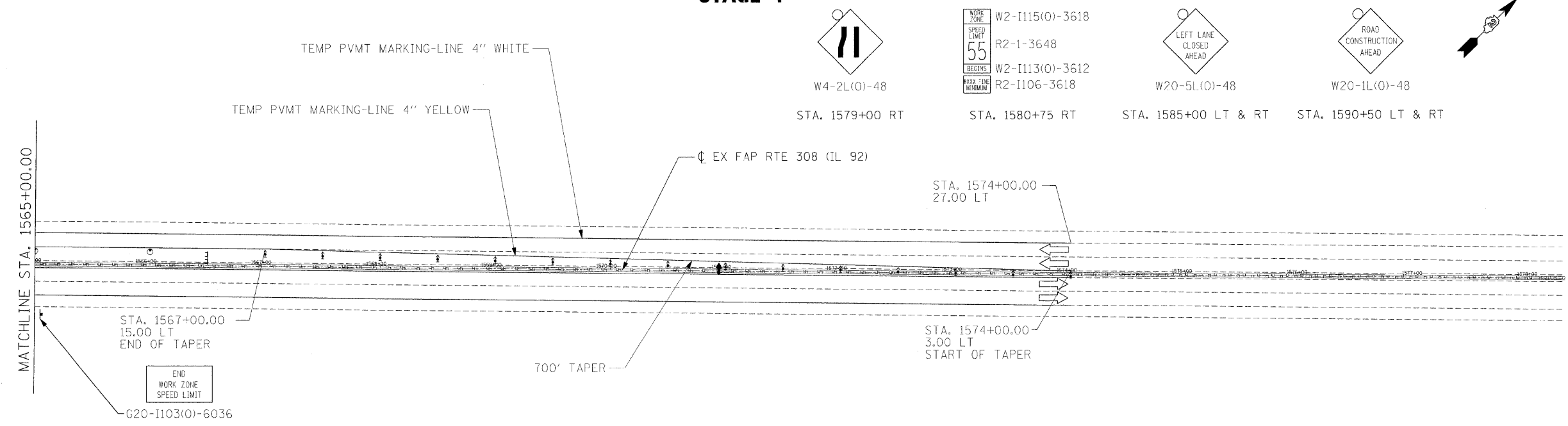

LEGEND

- DIRECTION OF TRAFFIC
- DRUM WITH STEADY BURN MONODIRECTIONAL LIGHT
- DIRECTION INDICATOR BARRICADE WITH STEADY BURN MONODIRECTIONAL LIGHT
- TYPE III BARRICADE WITH FLASHING MONODIRECTIONAL LIGHTS
- TEMPORARY CONCRETE BARRIER

PLOT DATE = 08/21/08
 FILE NAME = #FILES#
 PLOT SCALE = #SCALE#
 USER NAME = #USER#

F.A.P. RTE.	SECTION	COUNTY	TOTAL SHEETS	SHEET NO.
308	1 (WB-1, WB-2) R	ROCK ISLAND	210	678
STA. N/A		TO STA. N/A		
FED. ROAD DIST. NO. 2 ILLINOIS FED. AID PROJECT				

7TH AVENUE

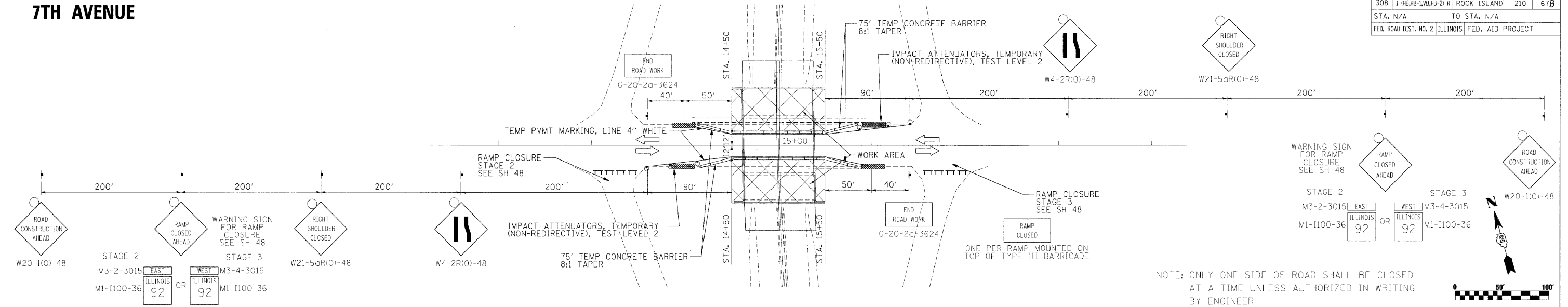

18TH AVENUE

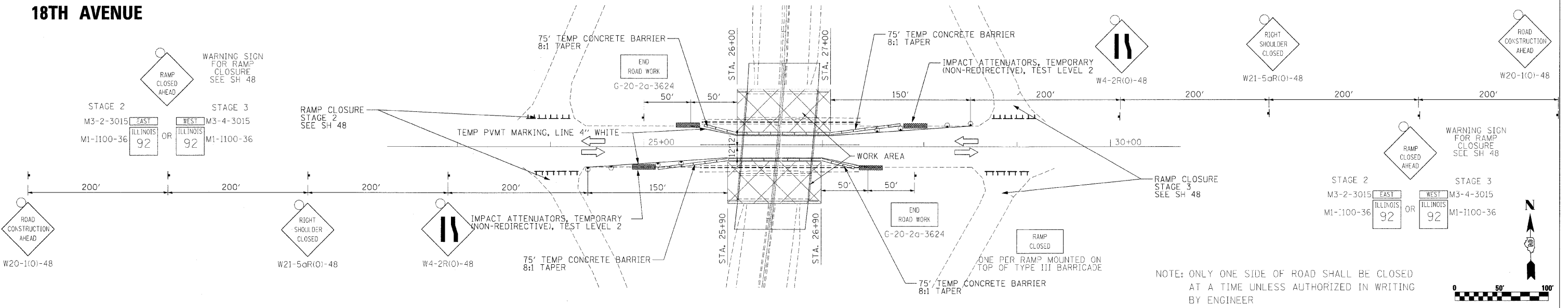

31ST AVENUE

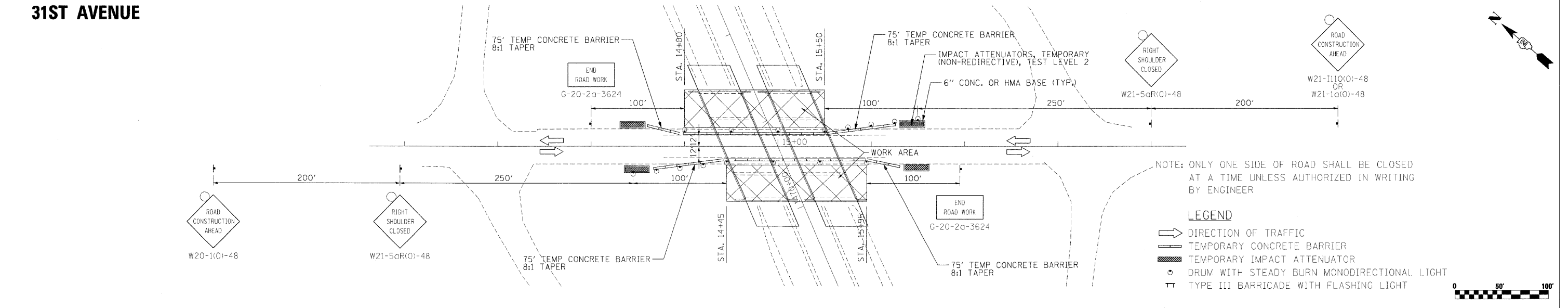

- LEGEND**
- ➔ DIRECTION OF TRAFFIC
 - ▬ TEMPORARY CONCRETE BARRIER
 - ▬ TEMPORARY IMPACT ATTENUATOR
 - DRUM WITH STEADY BURN MONODIRECTIONAL LIGHT
 - T TYPE III BARRICADE WITH FLASHING LIGHT

PLOT DATE * DATE * PLOT SCALE * USER NAME * USER#

CONTRACT NO. 64814				
F.A.P. RTE.	SECTION	COUNTY	TOTAL SHEETS	SHEET NO.
308	146B, 146C, 146D, 21R	ROCK ISLAND	210	68
STA. 1460+00		TO STA. 1465+00		
FED. ROAD DIST. NO. 2		ILLINOIS FED. AID PROJECT		

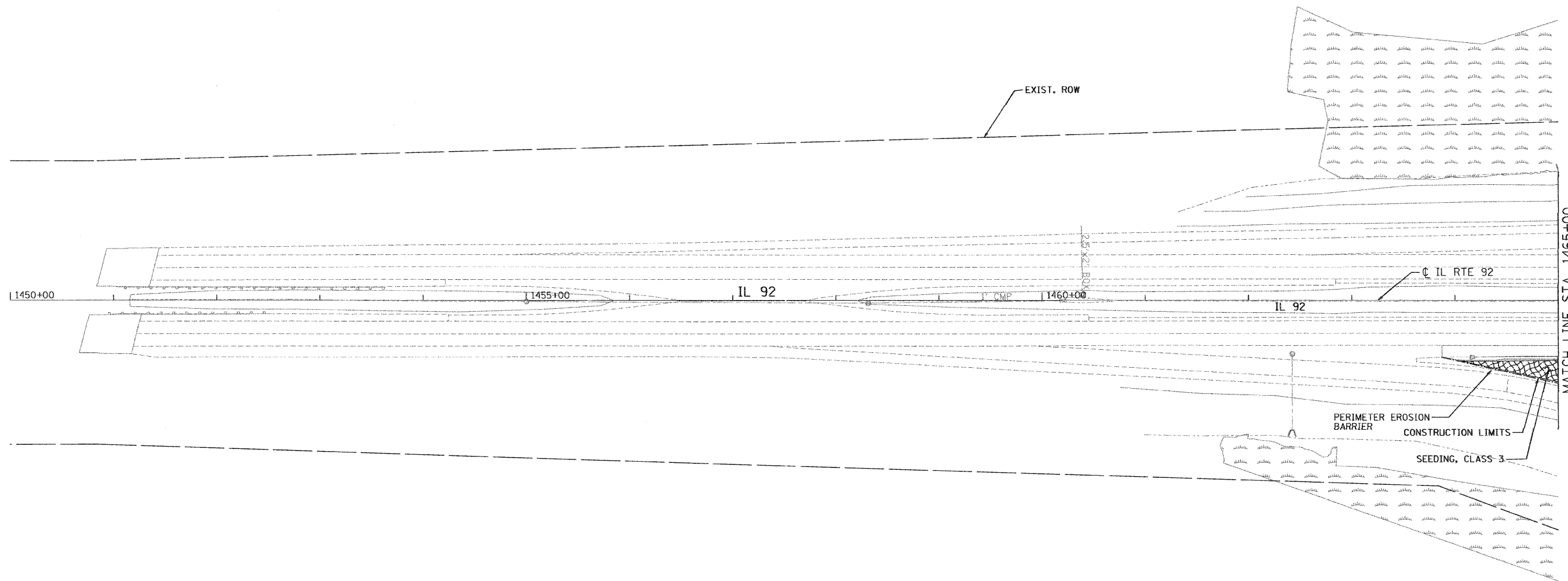

EROSION AND SEDIMENT CONTROL MEASURES APPLICATION NOTES:

1. PLACE THE PERIMETER EROSION BARRIER PRIOR TO ANY EXCAVATION OR GRADING ACTIVITIES. INSTALL PROTECTION AT LOCATIONS SHOWN ON THE PLANS.
2. PLACE EMBANKMENT FOR SHOULDER WIDENING AND STABILIZE WITH SEEDING, CLASS 3 AS THE SHOULDER WIDENING PROGRESSES. FOR ADDITIONAL STABILIZATION ON SLOPES 1:3 OR STEEPER USE EROSION CONTROL BLANKET.
3. TEMPORARILY SEED ANY BARE EARTH OR DISTURBED AREAS EVERY 7 DAYS IN ACCORDANCE WITH ARTICLE 280.04 OF THE STANDARD SPECIFICATIONS. SLOPES 1:3 OR STEEPER WILL REQUIRE MULCH, METHOD 2 APPLICATION.
4. FERTILIZER NUTRIENTS SHALL BE APPLIED IN ACCORDANCE WITH THE ARTICLE 250.04 OF THE STANDARD SPECIFICATIONS.

LEGEND:

- INLET PROTECTION STD 280001
- PERIMETER EROSION BARRIER
- STONE RIPRAP
- SEEDING, CLASS 3
- EROSION CONTROL BLANKET
- WETLANDS



REVISIONS	
NAME	DATE

ILLINOIS DEPARTMENT OF TRANSPORTATION

SCALE: VERT. HORIZ. DATE

DRAWN BY JW CHECKED BY MGZ

EROSION AND SEDIMENT CONTROL

PLOT DATE * DATE
 PLOT SCALE * SCALE
 USER NAME * USER

F.A.P. SECTION		COUNTY	TOTAL SHEETS	SHEET NO.
308	1000, 1010, 1020, 200	ROCK ISLAND	210	69
STA. 1465+00		TO STA. 1480+00		
FED. ROAD DIST. NO. 2		ILLINOIS	FED. AID PROJECT	

CONTRACT NO. 64814

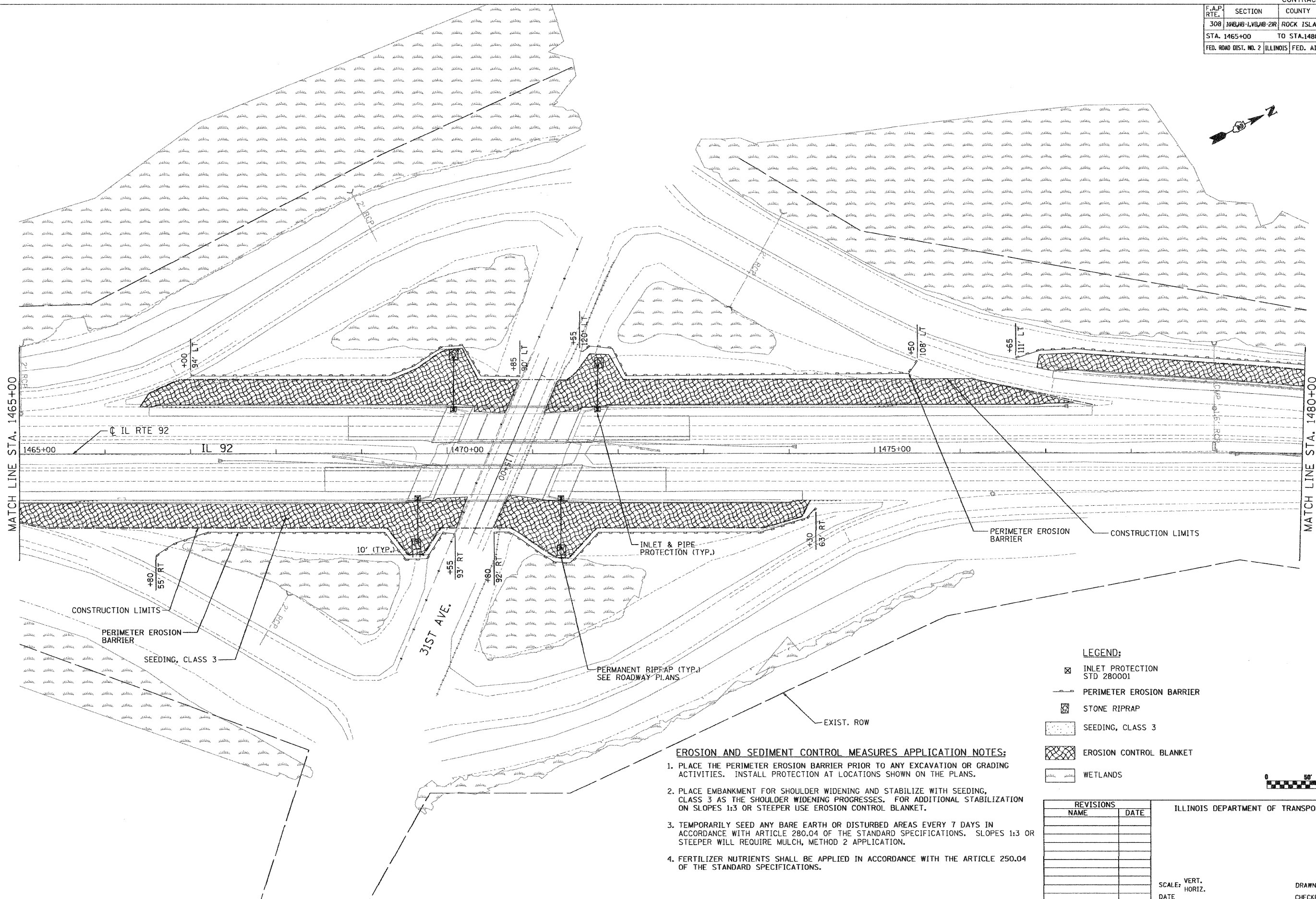
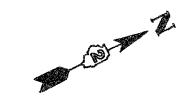

LEGEND:

- INLET PROTECTION STD 280001
- PERIMETER EROSION BARRIER
- STONE RIPRAP
- SEEDING, CLASS 3
- EROSION CONTROL BLANKET
- WETLANDS

EROSION AND SEDIMENT CONTROL MEASURES APPLICATION NOTES:

1. PLACE THE PERIMETER EROSION BARRIER PRIOR TO ANY EXCAVATION OR GRADING ACTIVITIES. INSTALL PROTECTION AT LOCATIONS SHOWN ON THE PLANS.
2. PLACE EMBANKMENT FOR SHOULDER WIDENING AND STABILIZE WITH SEEDING, CLASS 3 AS THE SHOULDER WIDENING PROGRESSES. FOR ADDITIONAL STABILIZATION ON SLOPES 1:3 OR STEEPER USE EROSION CONTROL BLANKET.
3. TEMPORARILY SEED ANY BARE EARTH OR DISTURBED AREAS EVERY 7 DAYS IN ACCORDANCE WITH ARTICLE 280.04 OF THE STANDARD SPECIFICATIONS. SLOPES 1:3 OR STEEPER WILL REQUIRE MULCH, METHOD 2 APPLICATION.
4. FERTILIZER NUTRIENTS SHALL BE APPLIED IN ACCORDANCE WITH THE ARTICLE 250.04 OF THE STANDARD SPECIFICATIONS.



REVISIONS	
NAME	DATE

ILLINOIS DEPARTMENT OF TRANSPORTATION

SCALE: VERT. DRAWN BY JW
 HORIZ. CHECKED BY MGZ
 DATE

EROSION AND SEDIMENT CONTROL

PLOT DATE * NUMBER *
 PLOT SCALE * NUMBER *
 USER NAME * NUMBER *

F.A.P. RTE.	SECTION	COUNTY	TOTAL SHEETS	SHEET NO.
308	10B,10-1,10B,10-2R	ROCK ISLAND	210	70
STA. 1480+00		TO STA. 1495+00		
FED. ROAD DIST. NO. 2		ILLINOIS	FED. AID PROJECT	

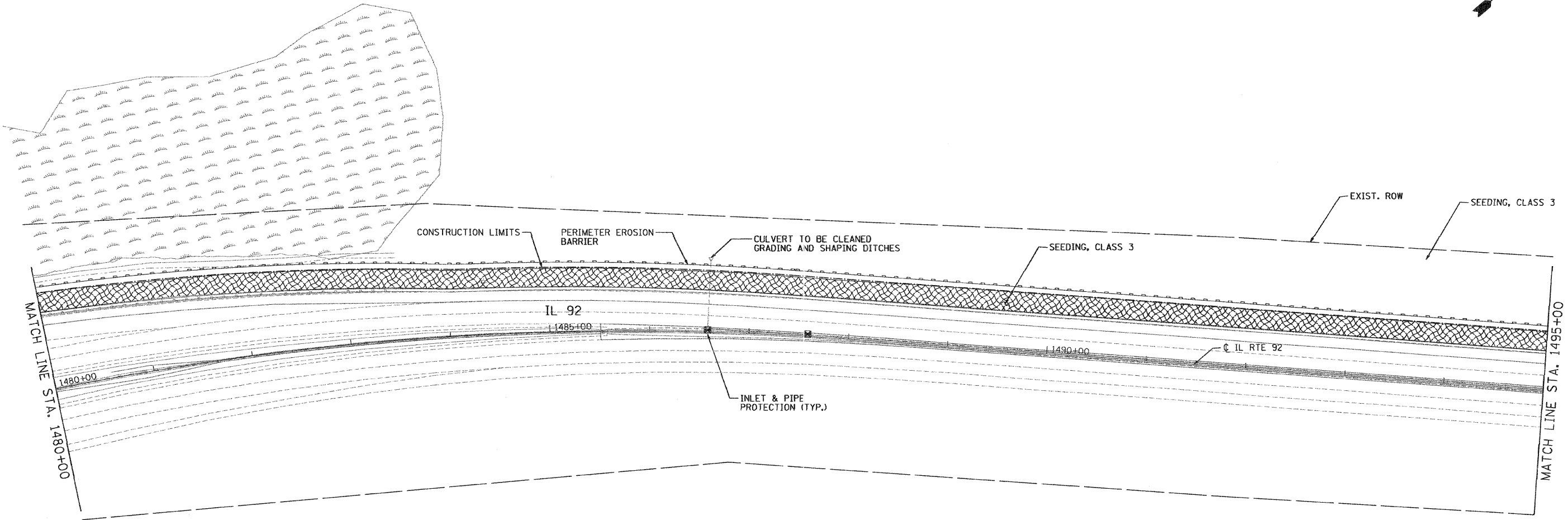
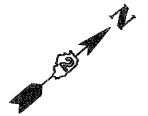

EROSION AND SEDIMENT CONTROL MEASURES APPLICATION NOTES:

1. PLACE THE PERIMETER EROSION BARRIER PRIOR TO ANY EXCAVATION OR GRADING ACTIVITIES. INSTALL PROTECTION AT LOCATIONS SHOWN ON THE PLANS.
2. PLACE EMBANKMENT FOR SHOULDER WIDENING AND STABILIZE WITH SEEDING, CLASS 3 AS THE SHOULDER WIDENING PROGRESSES. FOR ADDITIONAL STABILIZATION ON SLOPES 1:3 OR STEEPER USE EROSION CONTROL BLANKET.
3. TEMPORARILY SEED ANY BARE EARTH OR DISTURBED AREAS EVERY 7 DAYS IN ACCORDANCE WITH ARTICLE 280.04 OF THE STANDARD SPECIFICATIONS. SLOPES 1:3 OR STEEPER WILL REQUIRE MULCH, METHOD 2 APPLICATION.
4. FERTILIZER NUTRIENTS SHALL BE APPLIED IN ACCORDANCE WITH THE ARTICLE 250.04 OF THE STANDARD SPECIFICATIONS.

LEGEND:

- INLET PROTECTION STD 280001
- PERIMETER EROSION BARRIER
- STONE RIPRAP
- SEEDING, CLASS 3
- EROSION CONTROL BLANKET
- WETLANDS



REVISIONS	
NAME	DATE

ILLINOIS DEPARTMENT OF TRANSPORTATION

SCALE: VERT. HORIZ.
DATE
DRAWN BY JW
CHECKED BY MCZ

PLOT DATE * * * DATE * * *
PLOT SCALE * * * SCALE * * *
USER NAME * * * USER * * *

EROSION AND SEDIMENT CONTROL

F.A.P. RTE.	SECTION	COUNTY	TOTAL SHEETS	SHEET NO.
308	10B/JB-1,VB/JB-2/R	ROCK ISLAND	210	71
STA. 1495+00		TO STA. 1510+00		
FED. ROAD DIST. NO. 2		ILLINOIS	FED. AID PROJECT	

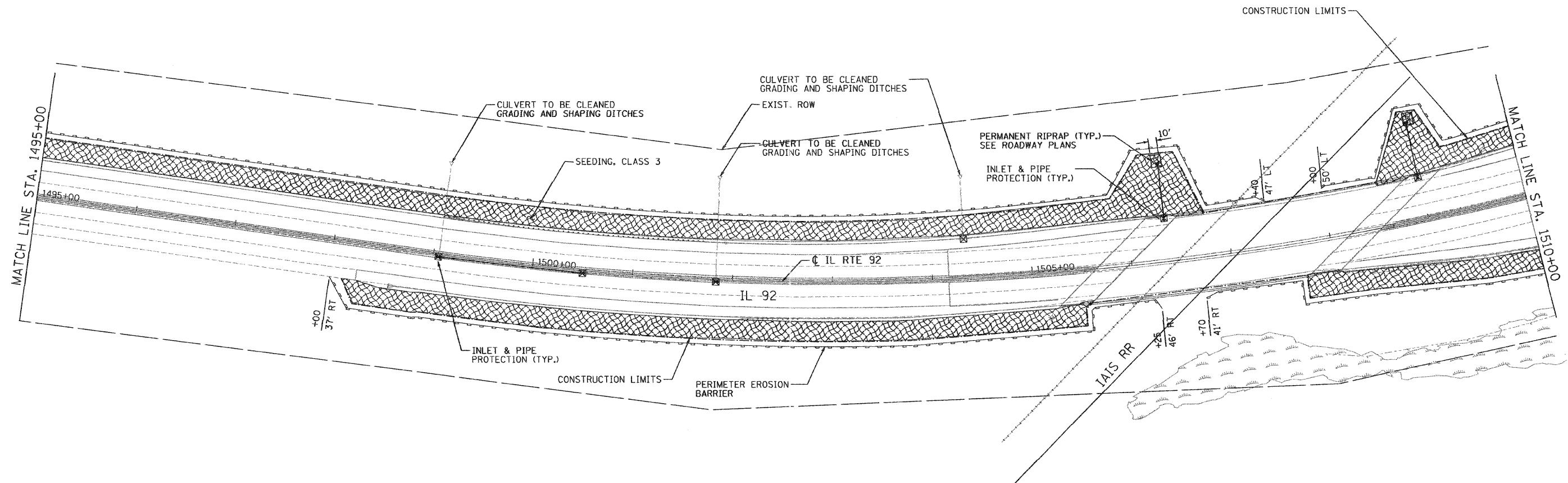
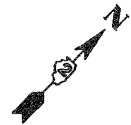

EROSION AND SEDIMENT CONTROL MEASURES APPLICATION NOTES:

1. PLACE THE PERIMETER EROSION BARRIER PRIOR TO ANY EXCAVATION OR GRADING ACTIVITIES. INSTALL PROTECTION AT LOCATIONS SHOWN ON THE PLANS.
2. PLACE EMBANKMENT FOR SHOULDER WIDENING AND STABILIZE WITH SEEDING, CLASS 3 AS THE SHOULDER WIDENING PROGRESSES. FOR ADDITIONAL STABILIZATION ON SLOPES 1:3 OR STEEPER USE EROSION CONTROL BLANKET.
3. TEMPORARILY SEED ANY BARE EARTH OR DISTURBED AREAS EVERY 7 DAYS IN ACCORDANCE WITH ARTICLE 280.04 OF THE STANDARD SPECIFICATIONS. SLOPES 1:3 OR STEEPER WILL REQUIRE MULCH, METHOD 2 APPLICATION.
4. FERTILIZER NUTRIENTS SHALL BE APPLIED IN ACCORDANCE WITH THE ARTICLE 250.04 OF THE STANDARD SPECIFICATIONS.

LEGEND:

- INLET PROTECTION STD 280001
- PERIMETER EROSION BARRIER
- STONE RIPRAP
- SEEDING, CLASS 3
- EROSION CONTROL BLANKET
- WETLANDS



REVISIONS	
NAME	DATE

ILLINOIS DEPARTMENT OF TRANSPORTATION

SCALE: VERT. HORIZ. DATE

DRAWN BY JW CHECKED BY MGZ

EROSION AND SEDIMENT CONTROL

PLOT DATE * DATE * PLOT SCALE * USER NAME * USER

F.A.P. RTE.	SECTION	COUNTY	TOTAL SHEETS	SHEET NO.
308	10B,11B-1,10B,11B-2R	ROCK ISLAND	210	72
STA. 1510+00		TO STA. 1525+00		
FED. ROAD DIST. NO. 2		ILLINOIS		FED. AID PROJECT

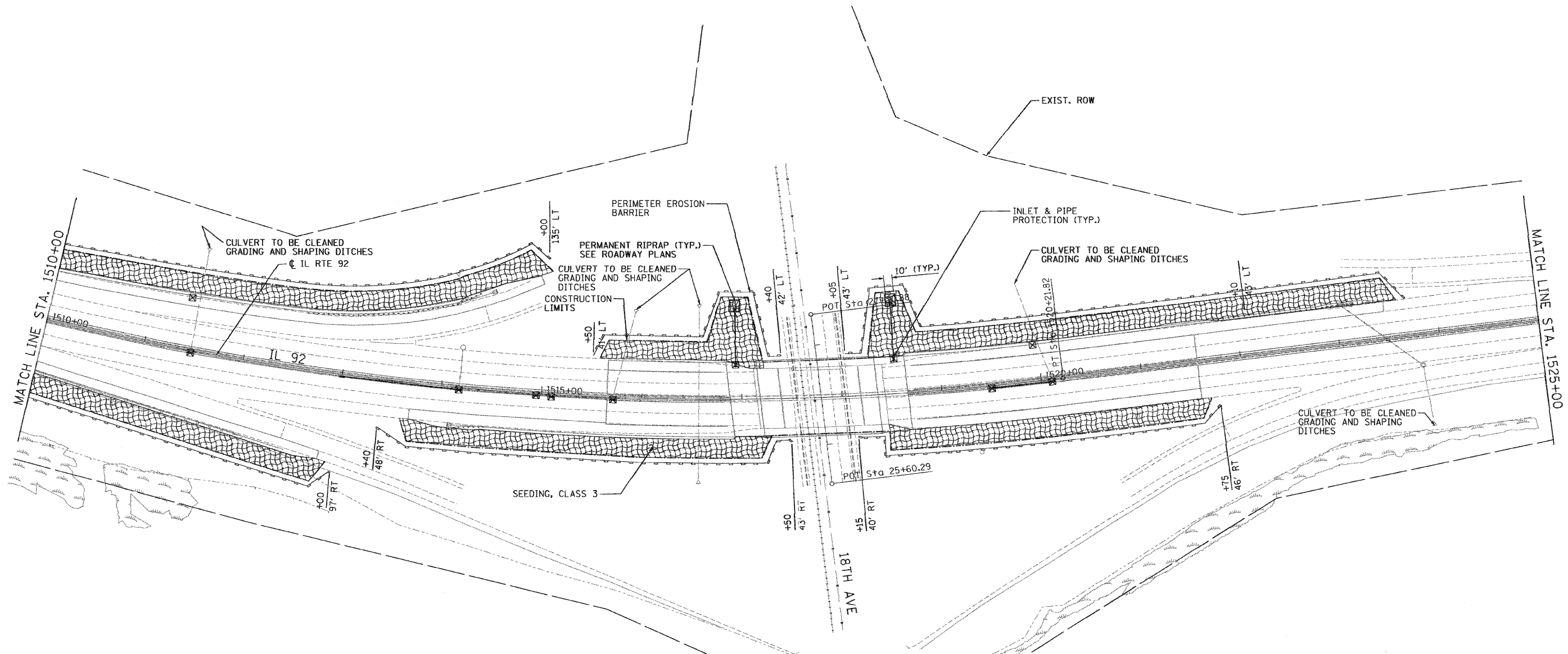

EROSION AND SEDIMENT CONTROL MEASURES APPLICATION NOTES:

1. PLACE THE PERIMETER EROSION BARRIER PRIOR TO ANY EXCAVATION OR GRADING ACTIVITIES. INSTALL PROTECTION AT LOCATIONS SHOWN ON THE PLANS.
2. PLACE EMBANKMENT FOR SHOULDER WIDENING AND STABILIZE WITH SEEDING, CLASS 3 AS THE SHOULDER WIDENING PROGRESSES. FOR ADDITIONAL STABILIZATION ON SLOPES 1:3 OR STEEPER USE EROSION CONTROL BLANKET.
3. TEMPORARILY SEED ANY BARE EARTH OR DISTURBED AREAS EVERY 7 DAYS IN ACCORDANCE WITH ARTICLE 280.04 OF THE STANDARD SPECIFICATIONS. SLOPES 1:3 OR STEEPER WILL REQUIRE MULCH, METHOD 2 APPLICATION.
4. FERTILIZER NUTRIENTS SHALL BE APPLIED IN ACCORDANCE WITH THE ARTICLE 250.04 OF THE STANDARD SPECIFICATIONS.

LEGEND:

- ☒ INLET PROTECTION STD 280001
- PERIMETER EROSION BARRIER
- ▣ STONE RIPRAP
- ▨ SEEDING, CLASS 3
- ▩ EROSION CONTROL BLANKET
- ▧ WETLANDS



REVISIONS	
NAME	DATE

ILLINOIS DEPARTMENT OF TRANSPORTATION

SCALE: VERT. _____
 HORIZ. _____
 DATE _____

DRAWN BY JW
 CHECKED BY MGZ

EROSION AND SEDIMENT CONTROL

PLOT DATE * * * * *
 PLOT TIME * * * * *
 PLOT SCALE * * * * *
 USER NAME * * * * *

F.A.P. RTE.	SECTION	COUNTY	TOTAL SHEETS	SHEET NO.
308	100B, 101B-1, 102B-2R	ROCK ISLAND	210	73
STA. 1525+00		TO STA. 1540+00		
FED. ROAD DIST. NO. 2		ILLINOIS	FED. AID PROJECT	

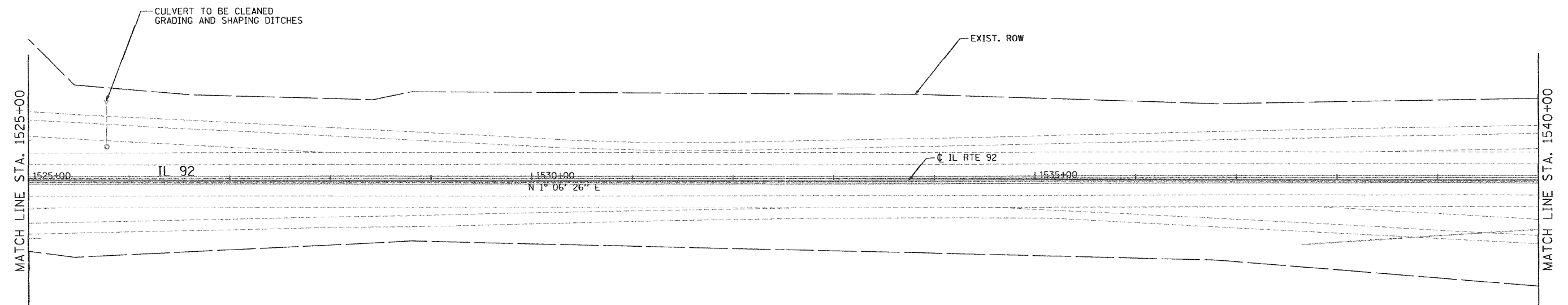

EROSION AND SEDIMENT CONTROL MEASURES APPLICATION NOTES:

1. PLACE THE PERIMETER EROSION BARRIER PRIOR TO ANY EXCAVATION OR GRADING ACTIVITIES. INSTALL PROTECTION AT LOCATIONS SHOWN ON THE PLANS.
2. PLACE EMBANKMENT FOR SHOULDER WIDENING AND STABILIZE WITH SEEDING, CLASS 3 AS THE SHOULDER WIDENING PROGRESSES. FOR ADDITIONAL STABILIZATION ON SLOPES 1:3 OR STEEPER USE EROSION CONTROL BLANKET.
3. TEMPORARILY SEED ANY BARE EARTH OR DISTURBED AREAS EVERY 7 DAYS IN ACCORDANCE WITH ARTICLE 280.04 OF THE STANDARD SPECIFICATIONS. SLOPES 1:3 OR STEEPER WILL REQUIRE MULCH, METHOD 2 APPLICATION.
4. FERTILIZER NUTRIENTS SHALL BE APPLIED IN ACCORDANCE WITH THE ARTICLE 250.04 OF THE STANDARD SPECIFICATIONS.

LEGEND:

- INLET PROTECTION STD 280001
- PERIMETER EROSION BARRIER
- STONE RIPRAP
- SEEDING, CLASS 3
- EROSION CONTROL BLANKET
- WETLANDS



REVISIONS	
NAME	DATE

ILLINOIS DEPARTMENT OF TRANSPORTATION

SCALE: VERT. _____
 HORIZ. _____
 DATE _____
 DRAWN BY JW
 CHECKED BY MGZ

PLOT DATE * DATE *
 PLOT SCALE * REVISIONS *
 USER NAME * USERID *

EROSION AND SEDIMENT CONTROL

F.A.D. RTE.	SECTION	COUNTY	TOTAL SHEETS	SHEET NO.
308	10B/B-1,VB/JB-2R	ROCK ISLAND	210	74
STA. 1540+00		TO STA. 1555+00		
FED. ROAD DIST. NO. 2		ILLINOIS FED. AID PROJECT		

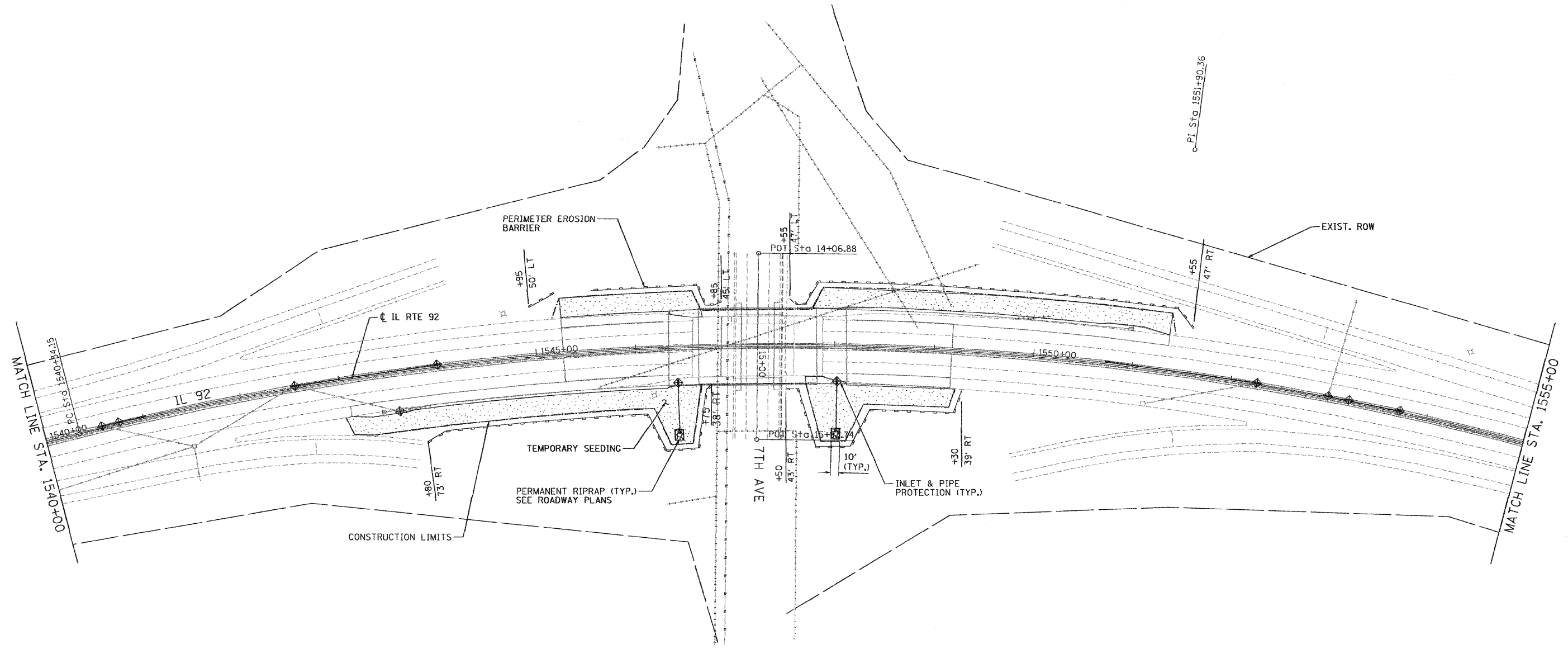

EROSION AND SEDIMENT CONTROL MEASURES APPLICATION NOTES:

1. PLACE THE PERIMETER EROSION BARRIER PRIOR TO ANY EXCAVATION OR GRADING ACTIVITIES. INSTALL PROTECTION AT LOCATIONS SHOWN ON THE PLANS.
2. PLACE EMBANKMENT FOR SHOULDER WIDENING AND STABILIZE WITH SEEDING, CLASS 3 AS THE SHOULDER WIDENING PROGRESSES. FOR ADDITIONAL STABILIZATION ON SLOPES 1:3 OR STEEPER USE EROSION CONTROL BLANKET.
3. TEMPORARILY SEED ANY BARE EARTH OR DISTURBED AREAS EVERY 7 DAYS IN ACCORDANCE WITH ARTICLE 280.04 OF THE STANDARD SPECIFICATIONS. SLOPES 1:3 OR STEEPER WILL REQUIRE MULCH, METHOD 2 APPLICATION.
4. FERTILIZER NUTRIENTS SHALL BE APPLIED IN ACCORDANCE WITH THE ARTICLE 250.04 OF THE STANDARD SPECIFICATIONS.

LEGEND:

- ☒ INLET PROTECTION STD 280001
- PERIMETER EROSION BARRIER
- ☒ STONE RIPRAP
- ▨ SEEDING, CLASS 3
- ▩ EROSION CONTROL BLANKET
- ▧ WETLANDS



REVISIONS	
NAME	DATE

ILLINOIS DEPARTMENT OF TRANSPORTATION

SCALE: VERT. HORIZ. DATE

DRAWN BY JW CHECKED BY MGZ

EROSION AND SEDIMENT CONTROL

PLOT DATE * DATE *
 PLOT SCALE * SCALE *
 USER NAME * USER *

F.A.D. RTE.	SECTION	COUNTY	TOTAL SHEETS	SHEET NO.
308	108L/10-1, 108L/10-2R	ROCK ISLAND	210	75
STA. 1555+00		TO STA. 1561+63.59		
FED. ROAD DIST. NO. 2		ILLINOIS	FED. AID PROJECT	

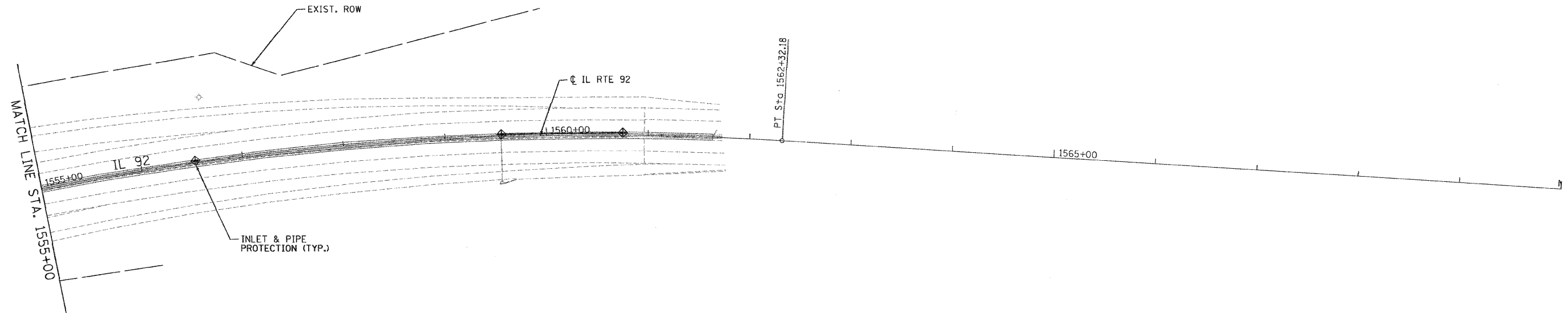

EROSION AND SEDIMENT CONTROL MEASURES APPLICATION NOTES:

1. PLACE THE PERIMETER EROSION BARRIER PRIOR TO ANY EXCAVATION OR GRADING ACTIVITIES. INSTALL PROTECTION AT LOCATIONS SHOWN ON THE PLANS.
2. PLACE EMBANKMENT FOR SHOULDER WIDENING AND STABILIZE WITH SEEDING, CLASS 3 AS THE SHOULDER WIDENING PROGRESSES. FOR ADDITIONAL STABILIZATION ON SLOPES 1:3 OR STEEPER USE EROSION CONTROL BLANKET.
3. TEMPORARILY SEED ANY BARE EARTH OR DISTURBED AREAS EVERY 7 DAYS IN ACCORDANCE WITH ARTICLE 280.04 OF THE STANDARD SPECIFICATIONS. SLOPES 1:3 OR STEEPER WILL REQUIRE MULCH, METHOD 2 APPLICATION.
4. FERTILIZER NUTRIENTS SHALL BE APPLIED IN ACCORDANCE WITH THE ARTICLE 250.04 OF THE STANDARD SPECIFICATIONS.

LEGEND:

- INLET PROTECTION STD 280001
- PERIMETER EROSION BARRIER
- STONE RIPRAP
- SEEDING, CLASS 3
- EROSION CONTROL BLANKET
- WETLANDS



REVISIONS	
NAME	DATE

ILLINOIS DEPARTMENT OF TRANSPORTATION

SCALE: VERT. HORIZ. DATE

DRAWN BY JW CHECKED BY MGZ

EROSION AND SEDIMENT CONTROL

PLOT DATE * DATE *
 PLOT SCALE * SCALE *
 USER NAME * USER *

F.A.P. RTE.	SECTION	COUNTY	TOTAL SHEETS	SHEET NO.
308	11#B-H-LWB-H-2R	ROCK ISLAND	210	76
STA. N/A		TO STA. N/A		
FED. ROAD DIST. NO. 2		ILLINOIS FED. AID PROJECT		

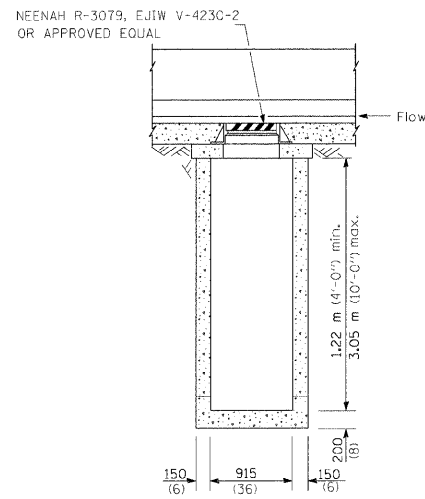

FRONT ELEVATION - TYPE 1 SPECIAL

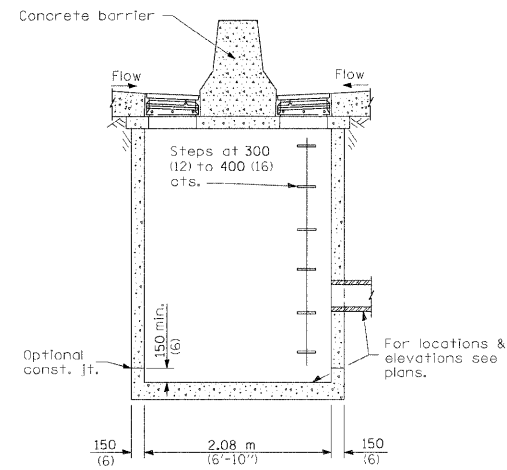

SIDE ELEVATION - TYPE 1 & 2 SPECIAL

DOUBLE UNIT NEENAH R-3077 FRAMES WITH R-3079 GRATES E.J.W. V-4232L AND V-4232R FRAMES WITH V-4230-2 GRATES OR APPROVED EQUAL

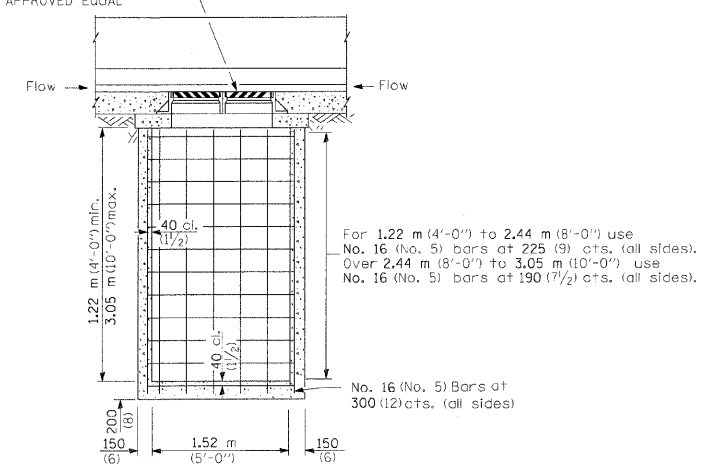

FRONT ELEVATION - TYPE 2 SPECIAL

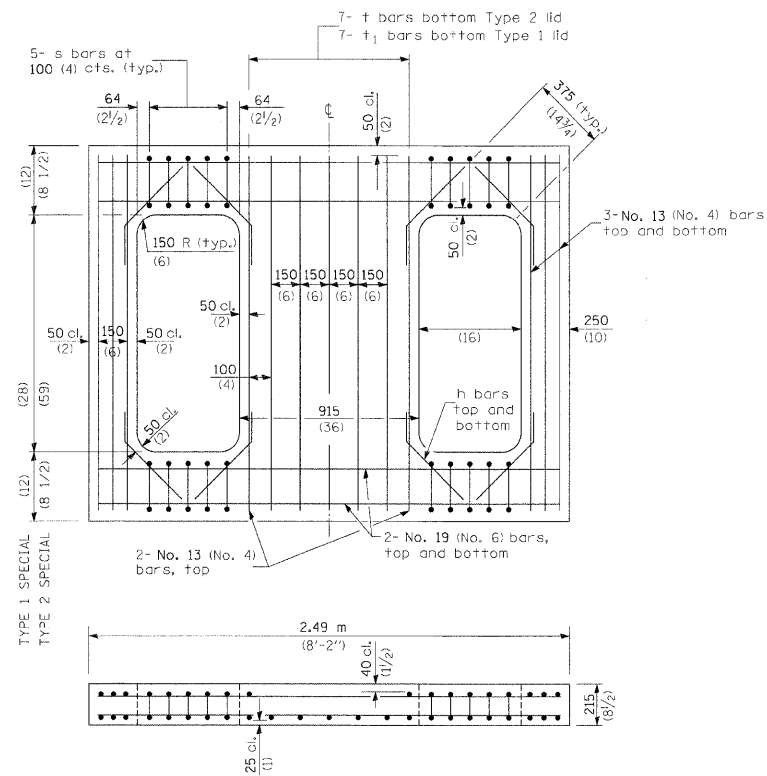

REINFORCED LID - TYPE 1 & 2

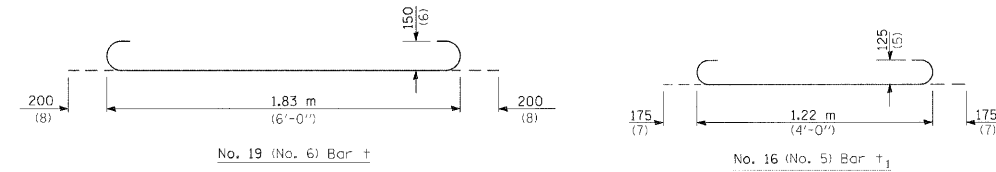
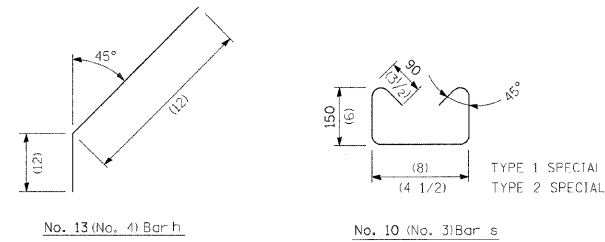

The details shown on this sheet are modifications due to narrow shoulder to standard 602101-01
All dimensions are in millimeters (inches) unless otherwise shown.

PLOT DATE = #DATE#
FILE NAME = #FILE#
PLOT SCALE = #SCALE#
USER NAME = #USER#

REVISIONS		ILLINOIS DEPARTMENT OF TRANSPORTATION
NAME	DATE	
		DRAINAGE STRUCTURES TYPES 1 & 2 SPECIAL

SCALE: VERT. DRAWN BY
HORIZ. CHECKED BY
DATE

DETAIL OF HOT-MIX ASPHALT SHOULDER AT GUARD RAIL

CONTRACT NO. 64814

F.A. RTE.	SECTION	COUNTY	TOTAL SHEETS	SHEET NO.
STA.		TO STA.		

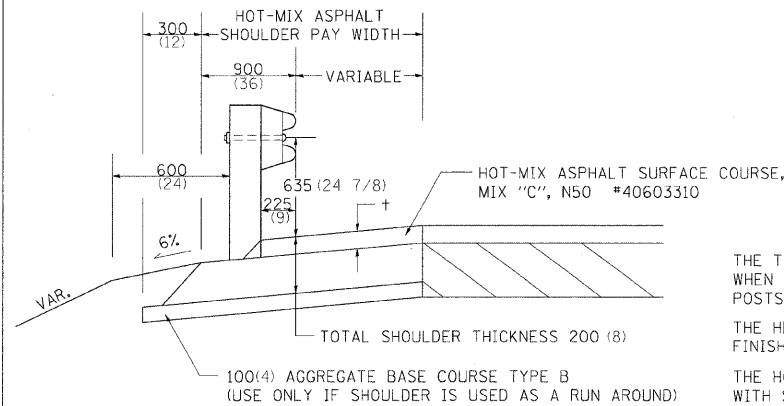

+ = SEE TYPICAL SECTIONS FOR THICKNESS

GENERAL NOTES

THE TOP LIFT SHALL NOT BE PLACED BEHIND THE GUARDRAIL POSTS. WHEN PLACING THE TOP LIFT THE RAIL MUST BE REMOVED FROM THE POSTS. THE POST SHALL NOT BE REMOVED.

THE HEIGHT OF THE GUARD RAIL SHALL BE SET 525 (21) FROM THE FINISHED SURFACE.

THE HOT-MIX ASPHALT SHOULDER SHALL BE CONSTRUCTED IN ACCORDANCE WITH SECTION 482 EXCEPT THE TOP LIFT SHALL BE HOT-MIX ASPHALT SURFACE COURSE, MIXTURE C, N50. THE WORK WILL BE PAID FOR AT THE CONTRACT UNIT PRICE PER TON FOR HOT-MIX ASPHALT SURFACE COURSE, MIXTURE "C", N50 AND SQUARE METER (SQUARE YARD) FOR HOT-MIX ASPHALT SHOULDERS OF THE THICKNESS SPECIFIED. THE REMOVAL & REINSTALLATION OF THE GUARDRAIL WILL BE INCLUDED IN THE COST OF THE HOT-MIX ASPHALT SURFACE COURSE, MIXTURE C, N50.

ALL DIMENSIONS ARE IN MILLIMETERS (INCHES) UNLESS OTHERWISE NOTED.

PLOT DATE * \$DATE*
 FILE NAME * \$FILEL*
 PLOT SCALE * \$SCALE*
 REFERENCE * \$REF*

DETAIL OF HOT-MIX ASPHALT SHOULDER AT GUARD RAIL 23.4

REVISED 10-06-06

DELINEATOR AND POST ORIENTATION

CONTRACT NO. 64814

F.A. RTE.	SECTION	COUNTY	TOTAL SHEETS	SHEET NO.
308	10HB,HB-1,VB,HB-2IR	ROCK ISLAND	210	77
STA.		TO STA.		
FED. ROAD DIST. NO.		ILLINOIS FED. AID PROJECT		

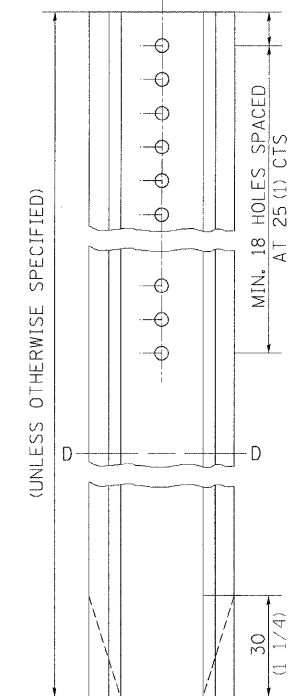
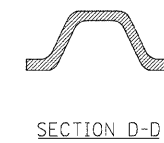
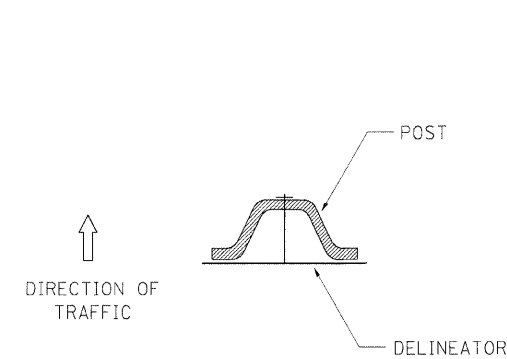

DELINEATORS SHALL BE INSTALLED ACCORDING TO STANDARD 635001 EXCEPT THAT THE POST SHALL BE ROTATED 180°. THE POST WILL HAVE THE WIDE SIDE FACING TRAFFIC AND THE DELINEATOR ATTACHED AS SHOWN ABOVE.

ALL DIMENSIONS ARE IN MILLIMETERS (INCHES) UNLESS OTHERWISE NOTED.

PLOT DATE * \$DATE*
 FILE NAME * \$FILEL*
 PLOT SCALE * \$SCALE*
 REFERENCE * \$REF*

DELINEATOR AND POST ORIENTATION 37.4

REVISED 1-31-00

HOT-MIX ASPHALT SHOULDER

CONTRACT NO.

F.A. RTE.	SECTION	COUNTY	TOTAL SHEETS	SHEET NO.
STA.		TO STA.		
FED. ROAD DIST. NO.		ILLINOIS FED. AID PROJECT		

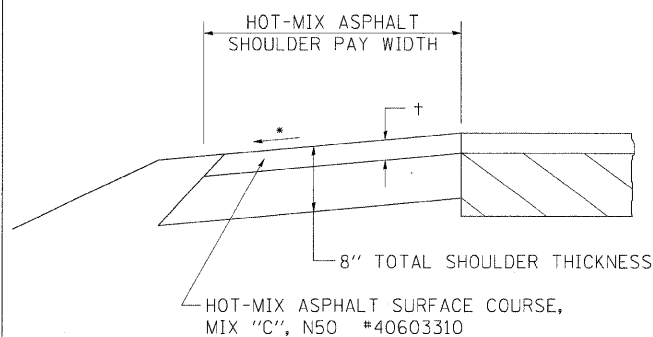

+ = SEE TYPICAL SECTIONS FOR THICKNESS

GENERAL NOTES

THE HOT-MIX ASPHALT SHOULDER SHALL BE CONSTRUCTED IN ACCORDANCE WITH SECTION 482 EXCEPT THE TOP LIFT SHALL BE HOT-MIX ASPHALT SURFACE COURSE, MIX "C", N50 #40603310. THE WORK WILL BE PAID FOR AT THE CONTRACT UNIT PRICE PER TON FOR HOT-MIX ASPHALT SURFACE COURSE, MIX "C", N50 #40603310 AND SQUARE YARD FOR HOT-MIX ASPHALT SHOULDERS OF THE THICKNESS SPECIFIED.

USE HOT-MIX ASPHALT SURFACE COURSE, MIX "C", N50 #40603310. WHEN RESURFACING EXISTING HOT-MIX ASPHALT SHOULDERS. THE THICKNESS IS SHOWN ON THE TYPICAL SECTIONS. THIS WORK WILL BE PAID FOR AT THE CONTRACT UNIT PRICE PER TON FOR HOT-MIX ASPHALT SURFACE COURSE, MIX "C", N50 #40603310.

REMOVAL OF MATERIAL FOR PLACEMENT OF THE HOT-MIX ASPHALT SHOULDER TO BE PAID FOR IN UNITS FOR EXCAVATING AND GRADING EXISTING SHOULDERS OR IN CUBIC YARDS FOR EARTH EXCAVATION OR EARTH EXCAVATION WIDENING.

* 4% WHEN MAINLINE IS ON TANGENT. FOR CROSS SLOPE ON SUPERELEVATION SECTION, SEE HIGHWAY STANDARD 482001 OR 482006.

ALL DIMENSIONS ARE IN MILLIMETERS (INCHES) UNLESS OTHERWISE NOTED.

PLOT DATE * \$DATE*
 FILE NAME * \$FILEL*
 PLOT SCALE * \$SCALE*
 REFERENCE * \$REF*

HOT-MIX ASPHALT SHOULDER 23.4a

REVISED 10-06-06

REQUIRED COLD MILLED SURFACE TEXTURE

CONTRACT NO.				
F.A. RTE.	SECTION	COUNTY	TOTAL SHEETS	SHEET NO.
308	10HB,HB-1,VB,HB-2IR	ROCK ISLAND	210	78
STA. TO STA.		FED. ROAD DIST. NO. ILLINOIS FED. AID PROJECT		

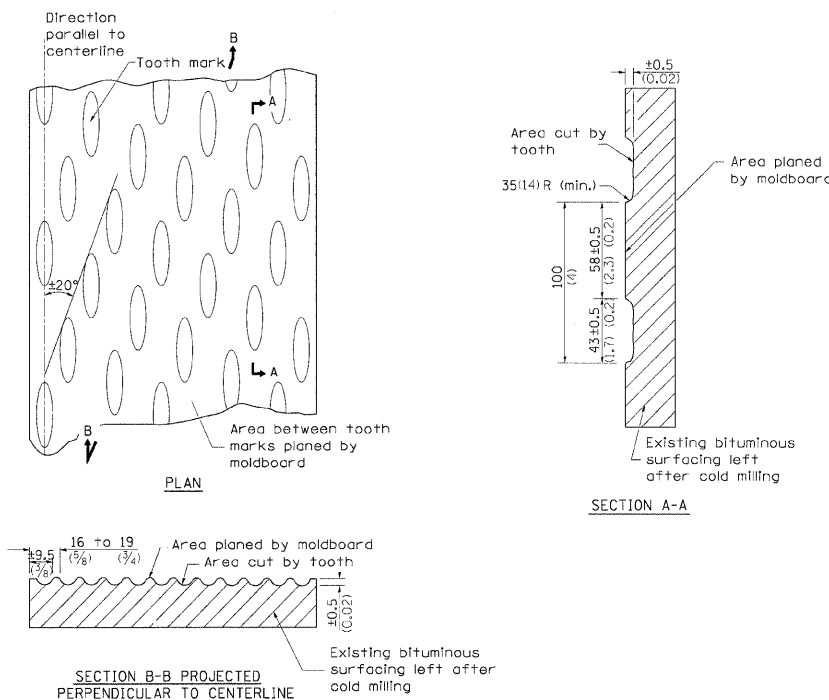

- NOTES**
1. Cold Milling shall consist of two processes: Cutting with carbide teeth mounted on a rotating drum, and planing with a moldboard mounted immediately behind the cutting drum.
 2. Other similar patterns will be acceptable if they consist of a smooth, flat, planed surface interspersed with a pattern of discontinuous longitudinal striations.
- ALL DIMENSIONS ARE IN MILLIMETERS (INCHES) UNLESS OTHERWISE NOTED.

REQUIRED COLD MILLED SURFACE TEXTURE 43.4

REVISED 5-1-96

PLOT DATE = #DATE#
FILE NAME = #FILE#
PLOT SCALE = #SCALE#
REFERENCE = #REF#

BARRIER REFLECTORS

CONTRACT NO. 64814				
F.A. RTE.	SECTION	COUNTY	TOTAL SHEETS	SHEET NO.
308	10HB,HB-1,VB,HB-2IR	ROCK ISLAND	210	78
STA. TO STA.		FED. ROAD DIST. NO. ILLINOIS FED. AID PROJECT		

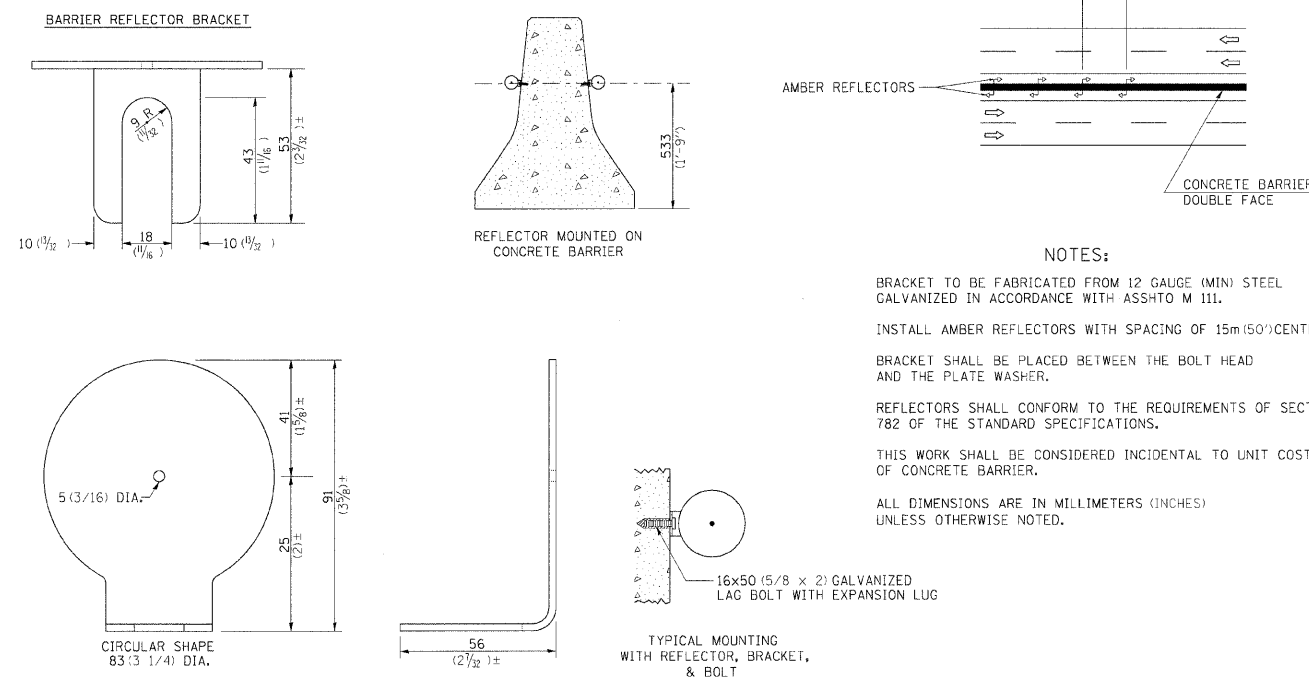

- NOTES:**
- BRACKET TO BE FABRICATED FROM 12 GAUGE (MIN) STEEL GALVANIZED IN ACCORDANCE WITH ASSHTO M 111.
- INSTALL AMBER REFLECTORS WITH SPACING OF 15m (50') CENTERS.
- BRACKET SHALL BE PLACED BETWEEN THE BOLT HEAD AND THE PLATE WASHER.
- REFLECTORS SHALL CONFORM TO THE REQUIREMENTS OF SECTION 782 OF THE STANDARD SPECIFICATIONS.
- THIS WORK SHALL BE CONSIDERED INCIDENTAL TO UNIT COST OF CONCRETE BARRIER.
- ALL DIMENSIONS ARE IN MILLIMETERS (INCHES) UNLESS OTHERWISE NOTED.

BARRIER REFLECTORS 92.4

REVISED 10-10-06

PLOT DATE = #DATE#
FILE NAME = #FILE#
PLOT SCALE = #SCALE#
REFERENCE = #REF#

LETTERING FOR NAME PLATE

CONTRACT NO.				
F.A. RTE.	SECTION	COUNTY	TOTAL SHEETS	SHEET NO.
308	10HB,HB-1,VB,HB-2IR	ROCK ISLAND	210	78
STA. TO STA.		FED. ROAD DIST. NO. ILLINOIS FED. AID PROJECT		

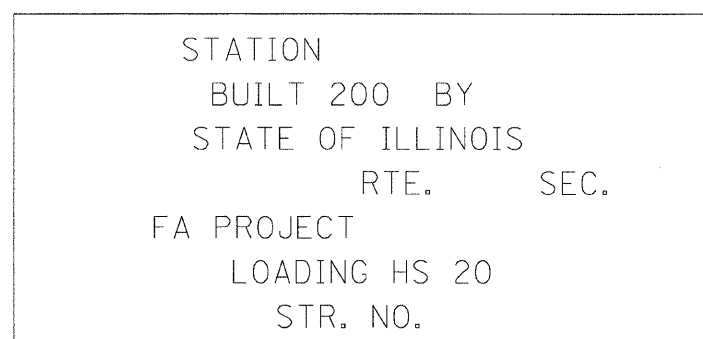

SEE STD. 515001

- DESIGNERS NOTE**
- WHEN USING A DOUBLE BOX CULVERT GET A STRUCTURE NUMBER AND SHOW IT ON THE GENERAL NOTES. IF THE DOUBLE BOX CULVERT IS EQUAL TO OR GREATER THAN 6.1m (20 FT) WIDE INCLUDE A PAY ITEM FOR NAME PLATES AND INCLUDE THIS DETAIL IN THE PLANS.
- ALL DIMENSIONS ARE IN MILLIMETERS (INCHES) UNLESS OTHERWISE NOTED.

LETTERING FOR NAME PLATE 89.4

REVISED 10-15-04

PLOT DATE = #DATE#
FILE NAME = #FILE#
PLOT SCALE = #SCALE#
REFERENCE = #REF#

TYPICAL MEDIAN CROSSOVER CLOSURE

CONTRACT NO.				
F.A. RTE.	SECTION	COUNTY	TOTAL SHEETS	SHEET NO.
308	10HB,HB-1,VB,HB-2IR	ROCK ISLAND	210	78
STA. TO STA.		FED. ROAD DIST. NO. ILLINOIS FED. AID PROJECT		

GENERAL NOTES

WOOD POSTS, CABLE, AND SIGN SUPPORTS SHALL BE IN ACCORDANCE WITH SECTION 634 & 636 OF THE STANDARD SPECIFICATIONS FOR ROAD AND BRIDGE CONSTRUCTION. THE PANELS SHALL BE ANCHORED TO THE (3/8") CABLE IN SUCH A MANNER SO THEY CANNOT SLIDE ALONG THE CABLE.

THE REFLECTIVE SHEETING USED FOR THE PANELS SHALL MEET THE REQUIREMENTS OF SECTION 1091 OF THE STANDARD SPECIFICATIONS FOR ROAD & BRIDGE CONSTRUCTION AND SHALL BE ON BOTH SIDES.

ALL PANELS SHALL HAVE ALTERNATING REFLECTORIZED WHITE & RED STRIPES SLOPING DOWNWARD AT 45° TOWARD THE SIDE ON WHICH TRAFFIC WILL PASS AND ON BOTH SIDES OF PANEL. THE DRILLING OF 75 (3) HOLES SHALL BE INCIDENTAL TO THE MEDIAN CLOSURE.

THIS WORK SHALL BE PAID FOR AT THE CONTRACT UNIT PRICE EACH FOR MEDIAN CLOSURE.

ALL DIMENSIONS ARE IN MILLIMETERS (INCHES) UNLESS OTHERWISE NOTED.

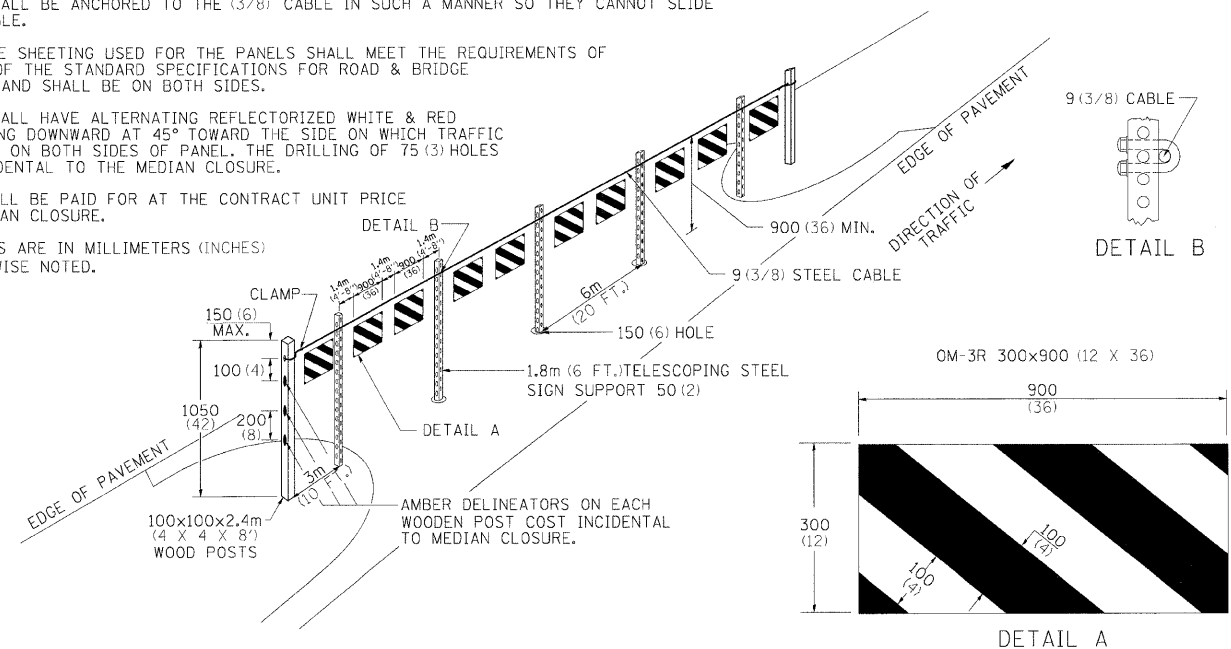

TYPICAL MEDIAN CROSSOVER CLOSURE 98.4

REVISED 10-10-06

PLOT DATE = #DATE#
FILE NAME = #FILE#
PLOT SCALE = #SCALE#
REFERENCE = #REF#

EROSION CONTROL DETAILS FOR SILT FENCE

CONTRACT NO.				
F.A. RTE.	SECTION	COUNTY	TOTAL SHEETS	SHEET NO.
30B	10HB,HB-1,VB,HB-2IR	ROCK ISLAND	210	79
STA.		TO STA.		
FED. ROAD DIST. NO.	ILLINOIS	FED. AID PROJECT		

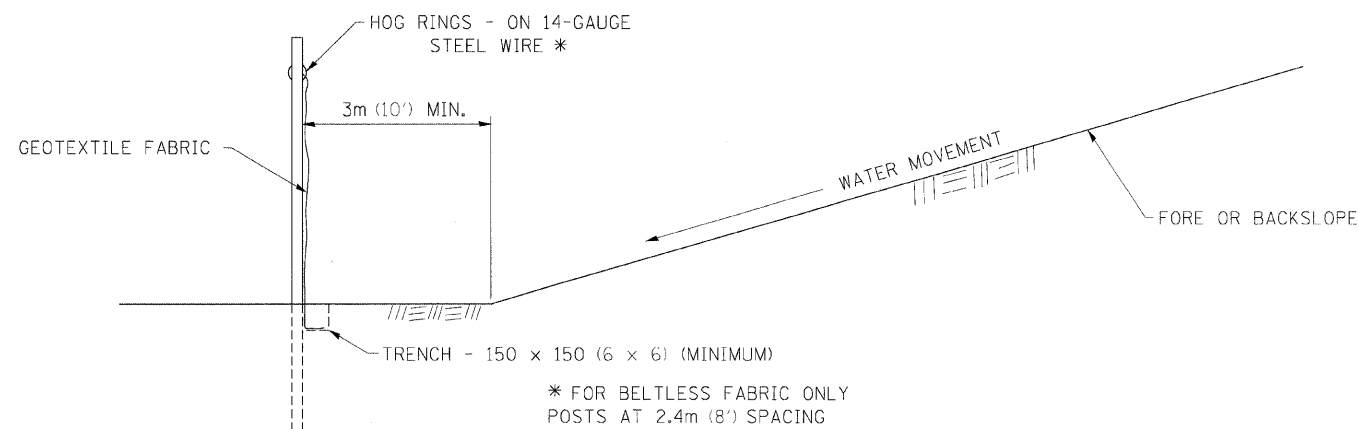
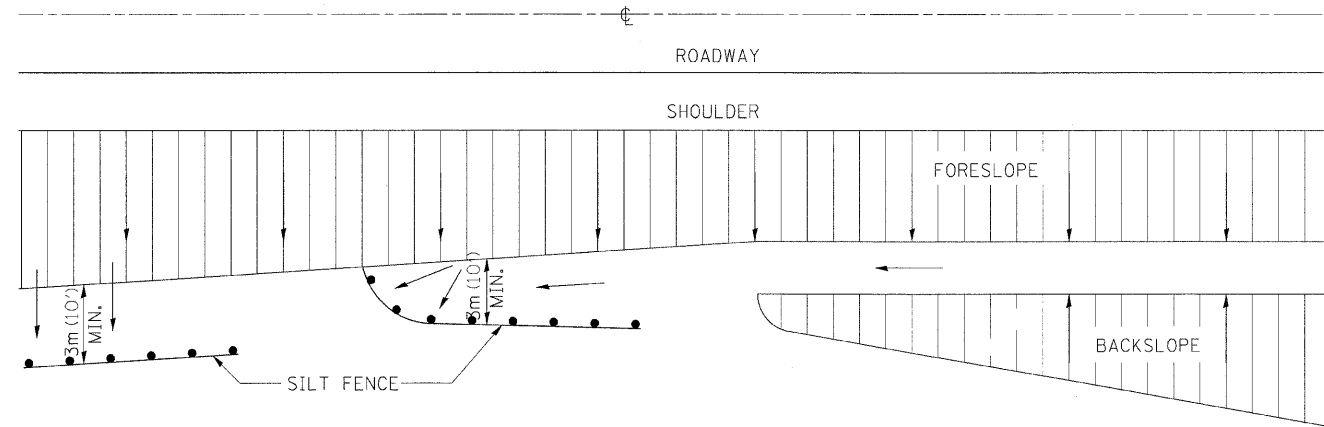

DETAILS OF SILT FENCE

ALL DIMENSIONS ARE IN MILLIMETERS (INCHES) UNLESS OTHERWISE NOTED.

PLOT DATE = #DATE#
FILE NAME = #FILE#
PLOT SCALE = #SCALE#
REFERENCE = #REF#

WITNESS MARKER FOR PERMANENT SURVEY MARKERS, TYPE II

CONTRACT NO. 64814				
F.A. RTE.	SECTION	COUNTY	TOTAL SHEETS	SHEET NO.
30B	10HB,HB-1,VB,HB-2IR	ROCK ISLAND	210	79
STA.		TO STA.		
FED. ROAD DIST. NO.	ILLINOIS	FED. AID PROJECT		

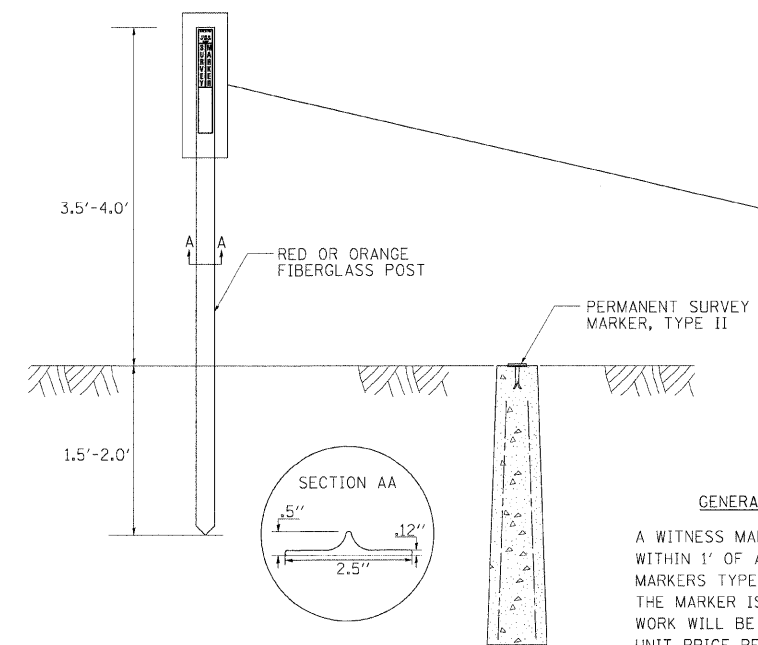

GENERAL NOTES

A WITNESS MARKER SHALL BE INSTALLED WITHIN 1' OF ALL PERMANENT SURVEY MARKERS TYPE II EXCEPT IN AREAS WHERE THE MARKER IS IN THE SIDEWALK. THIS WORK WILL BE INCLUDED TO THE CONTRACT UNIT PRICE PER EACH FOR PERMANENT SURVEY MARKERS, TYPE II.

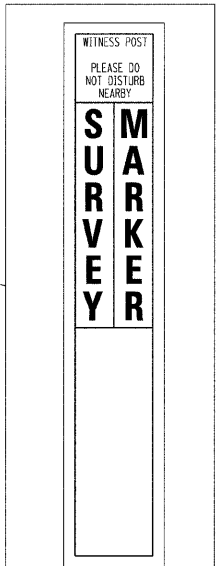

PERMANENT SURVEY MARKERS, TYPE II

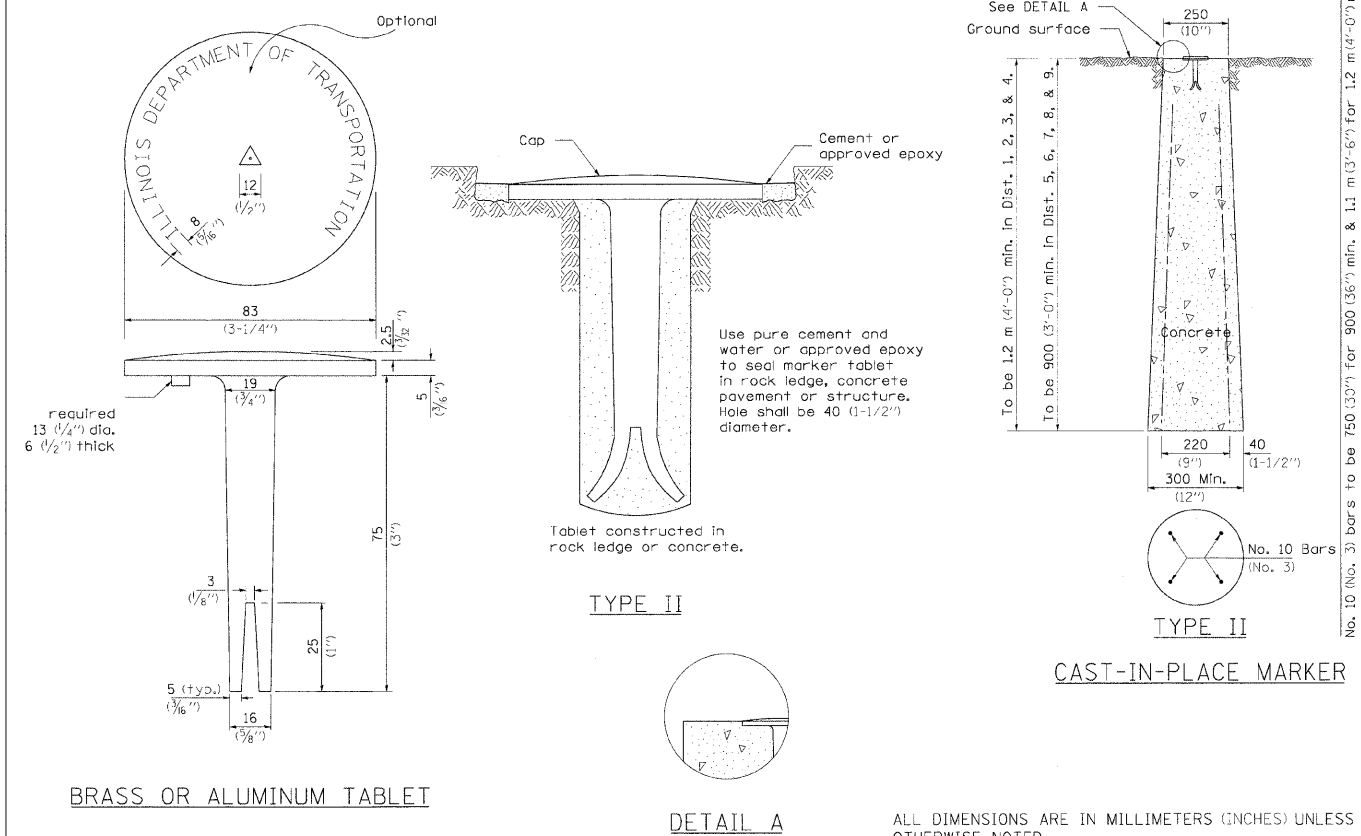

PLOT DATE = #DATE#
FILE NAME = #FILE#
PLOT SCALE = #SCALE#
REFERENCE = #REF#

ALL DIMENSIONS ARE IN MILLIMETERS (INCHES) UNLESS OTHERWISE NOTED.

STORM WATER POLLUTION PREVENTION PLAN EROSION CONTROL PLAN

F.A. RTE.	SECTION	COUNTY	TOTAL SHEETS	SHEET NO.
308	114B, 114B-1, 114B-2, 114B-2R	ROCK ISLAND	210	80
STA.	TO STA.			
FED. ROAD DIST. NO.	ILLINOIS	FED. AID PROJECT		

THE FOLLOWING PLAN WAS ESTABLISHED AND INCLUDED IN THESE PLANS TO DIRECT THE CONTRACTOR IN THE PLACEMENT OF TEMPORARY EROSION CONTROL SYSTEMS AND TO PROVIDE A STORM WATER POLLUTION PREVENTION PLAN FOR COMPLIANCE UNDER NPDES.

THE PURPOSE OF THIS PLAN IS TO MINIMIZE SILTATION WITHIN THE CONSTRUCTION ZONE AND TO ELIMINATE SEDIMENTS FROM ENTERING AND LEAVING THE CONSTRUCTION ZONE BY UTILIZING PROPER TEMPORARY EROSION CONTROL SYSTEMS AND PROVIDING GROUND COVER WITHIN A REASONABLE AMOUNT OF TIME.

CERTAIN ITEMS, AS SHOWN IN THIS PLAN AND REFERENCED BY THE LEGEND, SHALL BE PLACED BY THE CONTRACTOR AT THE BEGINNING OF CONSTRUCTION. OTHER ITEMS SHALL BE PLACED BY THE CONTRACTOR AS DIRECTED BY THE ENGINEER ON A CASE BY CASE SITUATION RESULTING FROM THE CONTRACTOR'S SEQUENCE OF ACTIVITIES, TIME OF YEAR, AND EXPECTED WEATHER CONDITIONS.

THE CONTRACTOR SHALL PLACE PERMANENT EROSION CONTROL SYSTEMS AND SEEDING WITHIN A REASONABLE AMOUNT OF TIME; THEREFORE, REDUCING THE AMOUNT OF AREA BEING OPEN TO THE POSSIBILITY OF EROSION AND REDUCING THE AMOUNT OF TEMPORARY SEEDING. THE RESIDENT ENGINEER WILL DETERMINE IF TEMPORARY EROSION CONTROL SYSTEMS SHOWN IN THE PLAN CAN BE DELETED, THE SIZE OF THE PROPOSED DITCH CHECKS, THE PROPER METHOD OF INSTALLATION, AND IF ANY ADDITIONAL TEMPORARY EROSION CONTROL SYSTEMS SHALL BE ADDED WHICH ARE NOT INCLUDED IN THE PLANS. THE CONTRACTOR SHALL PERFORM ALL WORK AS DIRECTED BY THE ENGINEER AND AS SHOWN IN STANDARD 280001 OF THE PLANS.

SITE DESCRIPTION

DESCRIPTION OF CONSTRUCTION ACTIVITY:

THIS PROJECT CONSISTS OF REPLACEMENT OF 3 BRIDGES INCLUDING FOUNDATIONS AND SLOPEWALLS, REPLACEMENT OF 1 BRIDGE DECK, SHOULDER WIDENING, GUARDRAIL INSTALLATION AND SEEDING

DESCRIPTION OF INTENDED SEQUENCE OF ACTIVITIES:

THE SEQUENCE OF EVENTS ARE AS FOLLOW: CLEARING, EMBANKMENT, EXCAVATION, GRADING AND PAVING. THIS PROJECT WILL BE CONSTRUCTED IN SEGMENTS AS SHOWN IN THE "STAGING PLANS".

TOTAL CONSTRUCTION SITE (CONSTRUCTION LIMIT TO CONSTRUCTION LIMIT) 25.0 ACRES

PROPOSED R.O.W (TOTAL PARCEL AREA) 0.0 ACRES

DISTURBED BY EXCAVATION (E.O.P TO CONSTRUCTION LIMIT) 4.8 ACRES

SUPPORTING REPORTS AND PLANS

THE FOLLOWING ASSISTED IN DEVELOPING THE EROSION CONTROL PLAN AS REFERENCED DOCUMENTS:

SOIL PROFILE SHEETS, SOILS REPORTS, BORING LOGS
USGS DRAINAGE MAPS, PROJECT PLAN DOCUMENTS

DRAINAGE TRIBUTARIES RECEIVING WATER FROM CONSTRUCTION SITE

MISSISSIPPI RIVER

ROCK RIVER

EROSION CONTROLS AND SEDIMENT CONTROL PROCEDURES

STABILIZATION PRACTICES AT THE BEGINNING OF CONSTRUCTION:

PERIMETER EROSION CONTROL SHALL BE PLACED PRIOR TO BEGINNING EARTHWORK.

STABILIZATION PRACTICES DURING CONSTRUCTION:

AS EARTH EXCAVATION AND EMBANKMENT ARE BEING COMPLETED THE CONTRACTOR SHALL PLACE DITCH CHECKS, INLET AND PIPE PROTECTION, EROSION CONTROL BLANKET, AND SEEDING AS STAGES OF THE PROJECT ARE COMPLETED. PERIMETER EROSION BARRIER WILL BE INSTALLED AT ADDITIONAL LOCATIONS AS THE PROJECT PROGRESSES. SEEDING SHALL BE COMPLETED AS SPECIFIED IN THE EROSION CONTROL/ SEEDING MOBILIZATION AND TEMPORARY SEEDING SPECIAL PROVISION.

MAINTENANCE AFTER FINAL GRADING

TEMPORARY EROSION CONTROL SYSTEMS SHALL BE LEFT IN PLACE WITH PROPER MAINTENANCE UNTIL PERMANENT EROSION CONTROL IS IN PLACE AND WORKING PROPERLY AND ALL PROPOSED TURF AREAS SEEDED AND ESTABLISHED WITH THE PROPER STAND. ONCE PERMANENT EROSION CONTROL SYSTEMS AS PROPOSED IN THE PLANS ARE FUNCTIONAL AND ESTABLISHED, TEMPORARY ITEMS SHALL BE REMOVED, CLEANED UP AND DISTURBED TURF RESEDED.

PLOT DATE = #DATE#
 FILE NAME = #FILE#
 PLOT SCALE = #SCALE#
 REFERENCE = #REF#

F.A. RTE.	SECTION	COUNTY	TOTAL SHEETS	SHEET NO.
308	16B,16B-1,16B,16B-2R	ROCK ISLAND	210	81
STA.	TO STA.			
FED. ROAD DIST. NO.	ILLINOIS	FED. AID PROJECT		

TYPICAL PAVEMENT MARKINGS

TYPICAL PAVEMENT MARKING FOR FLUSH MEDIAN AT LEFT TURN LANE

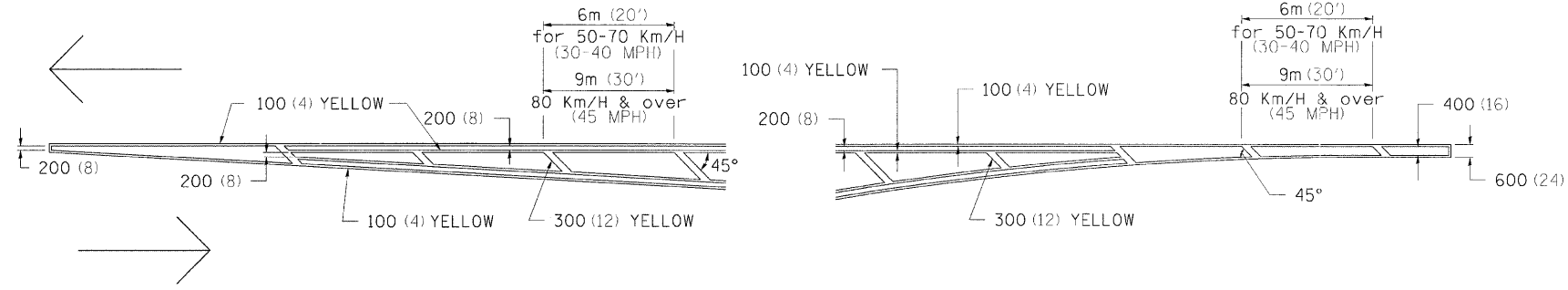

MEDIAN PAVEMENT MARKING

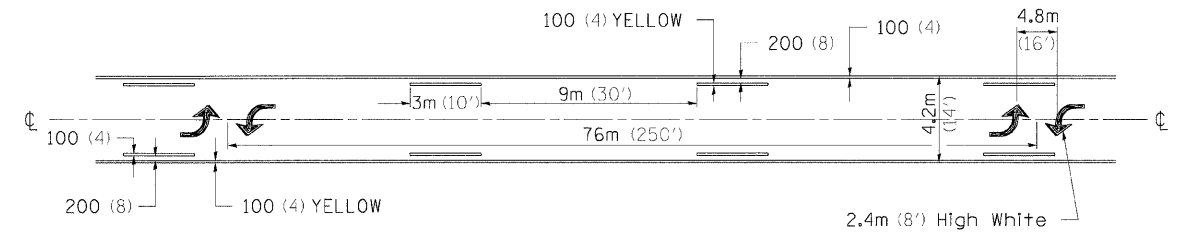

TYPICAL ISLAND OFFSET SHOULDER WIDTH

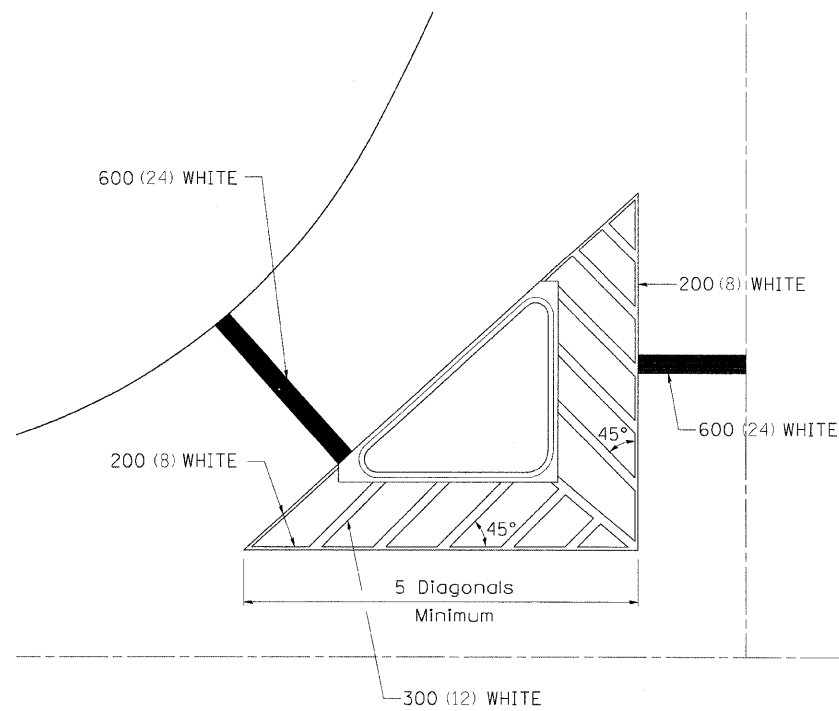

TYPICAL PARKING SPACING

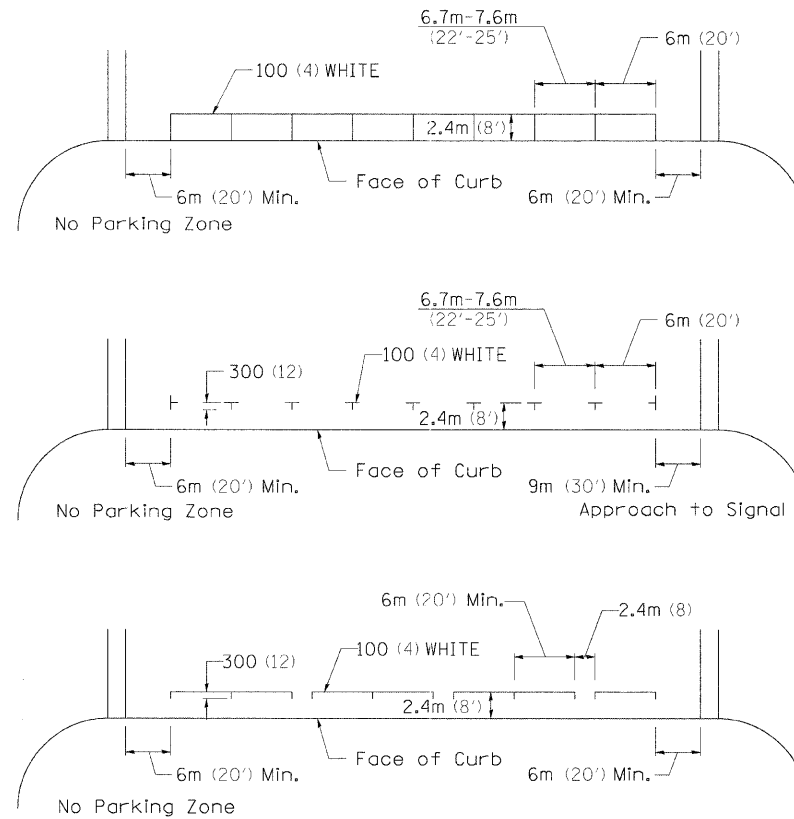

** ALL DIMENSIONS ARE IN MILLIMETERS (INCHES) UNLESS OTHERWISE NOTED.

STANDARD CROSSWALK MARKING

See Schedules for Locations

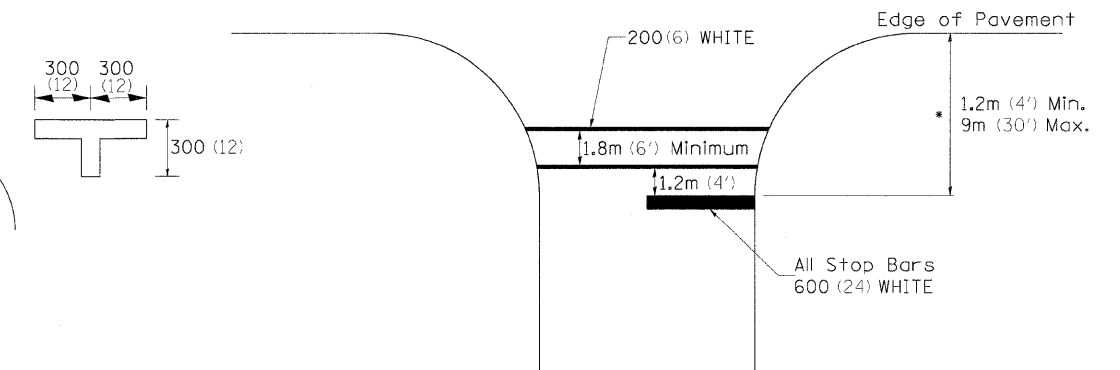

• Distance to the nearest edge of the intersecting roadway in the absence of a marked crosswalk.

PLOT DATE = 8/11/15
 FILE NAME = 8151515
 PLOT SCALE = 1:1
 REFERENCE = 8151515

F.A. RTE.	SECTION	COUNTY	TOTAL SHEETS	SHEET NO.
308	101B/HB-1,VB/HB-2/R	ROCK ISLAND	210	82
STA. TO STA.				
FED. ROAD DIST. NO.		ILLINOIS	FED. AID PROJECT	

TYPICAL PAVEMENT MARKINGS

ARROW LAYOUT

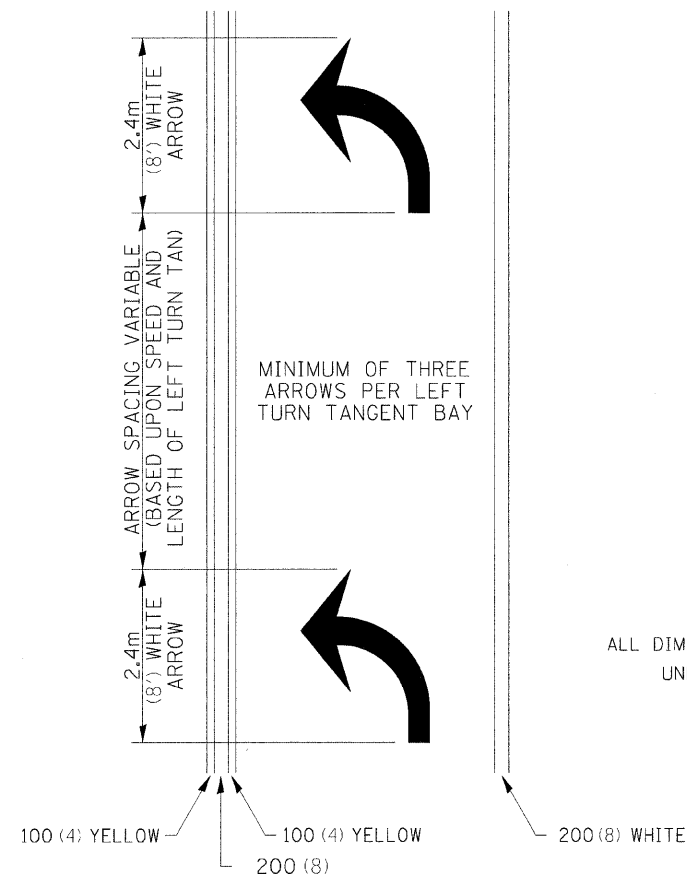

- ▲ ONE-WAY AMBER MARKER
- △ ONE-WAY CRYSTAL MARKER
- ◆ TWO-WAY AMBER MARKER

ALL DIMENSIONS ARE IN MILLIMETERS (INCHES) UNLESS OTHERWISE NOTED.

12.2m
6 at (40') O.C.
APPROACH SIDE ONLY

See Typical Drawing at right

TYPICAL PAVEMENT MARKING FOR FLUSH MEDIAN

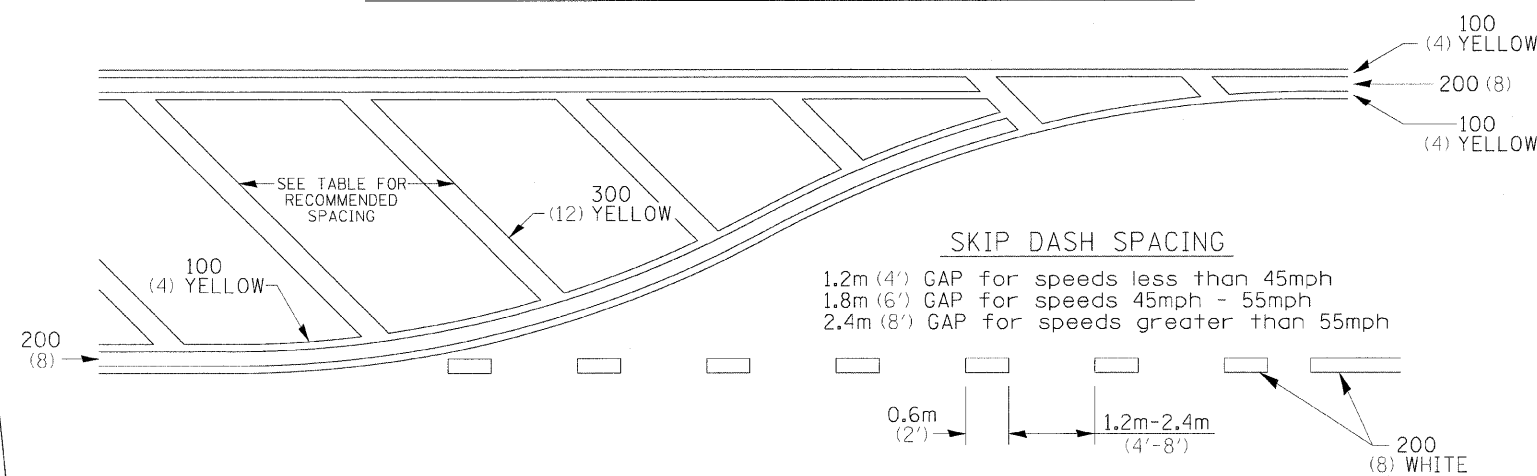

RECOMMENDED SPACING BETWEEN DIAGONALS (IN FEET)

Speed Limit Range	Continuous Median Area	Intersection Channelization	Objects (Islands)
less than 50Km/H (30MPH)	15.3m (50')	4.53m (15')	3.05m (10')
50-60Km/H (30-40MPH)	22.9m (75')	6.1m (20')	4.53m (15')
70Km/H (45MPH) & over	22.9m (75')	9.05m (30')	6.1m (20')

NOTE: if the spacing recommended in the Table does not permit at least five diagonal lines in the area being marked, the spacing from the next lowest speed range should be used. The recommended spacing is measured parallel to the pavement center line.

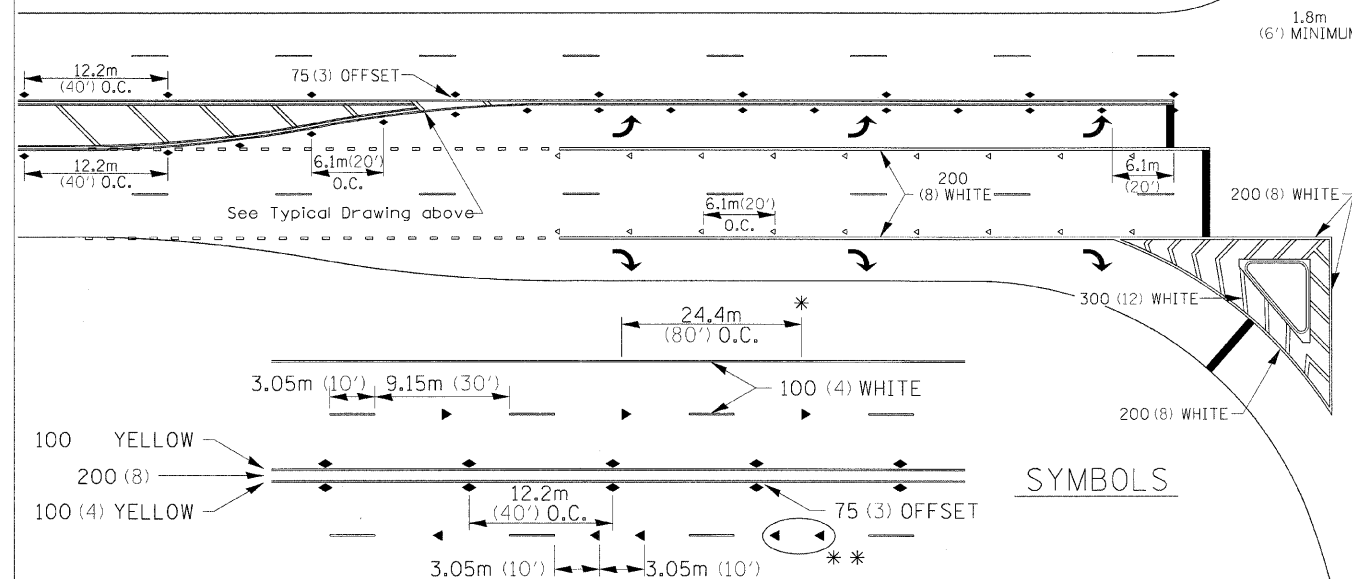

SYMBOLS

- * REDUCE TO 12.2m (40') O.C. ON CURVES WHERE ADVISORY SPEEDS ARE 15Km/H (10MPH) LOWER THAN POSTED SPEEDS.
- ** USE DOUBLE MARKERS WHEN ADT ≥ 25,000

MULTI-LANE / UNDIVIDED

12.2m
6 at (40') O.C.
APPROACH SIDE ONLY

TYPICAL PAVEMENT MARKING FOR TWO LANE SECTION - NO PASSING ZONES

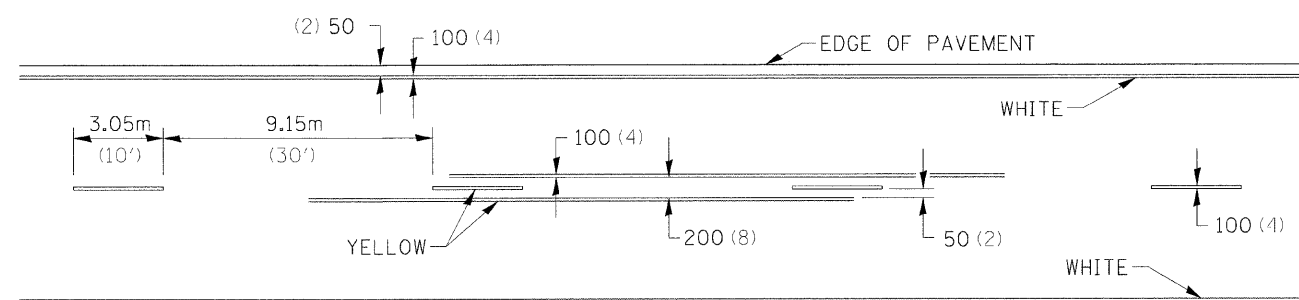

F.A. RTE.	SECTION	COUNTY	TOTAL SHEETS	SHEET NO.
30B	10B,HR-1,VB,HR-2R	ROCK ISLAND	210	82A
STA.		TO STA.		
FED. ROAD DIST. NO.	ILLINOIS	FED. AID PROJECT		

PAINING DETAILS

EXIT RAMP

NOTE: GORE HATCHING PLACED ONLY WHEN SCHEDULED IN TH PLANS

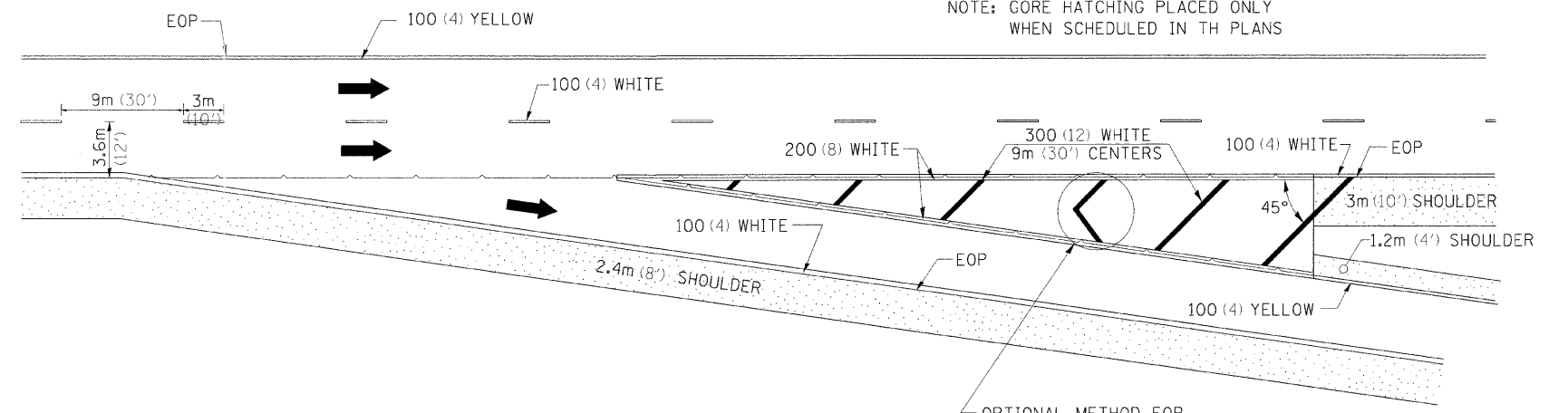

ENTRANCE RAMP

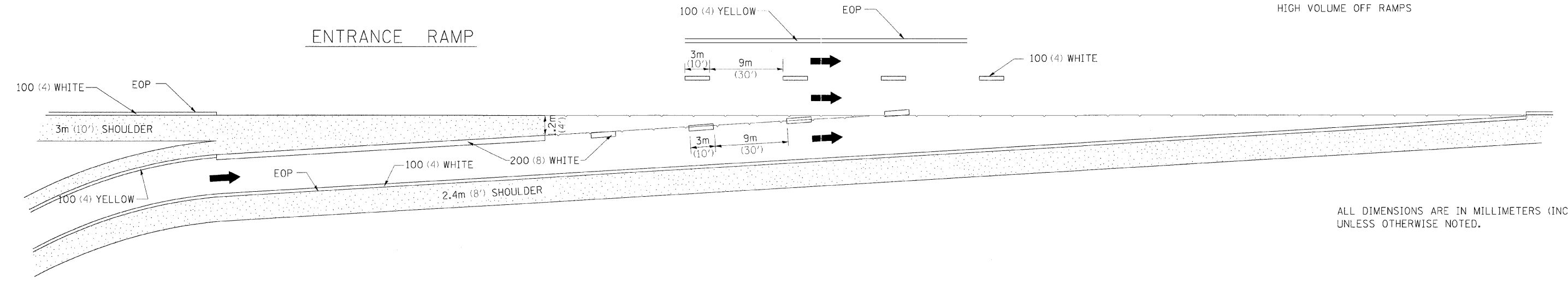

ALL DIMENSIONS ARE IN MILLIMETERS (INCHES) UNLESS OTHERWISE NOTED.

CLOVERLEAF

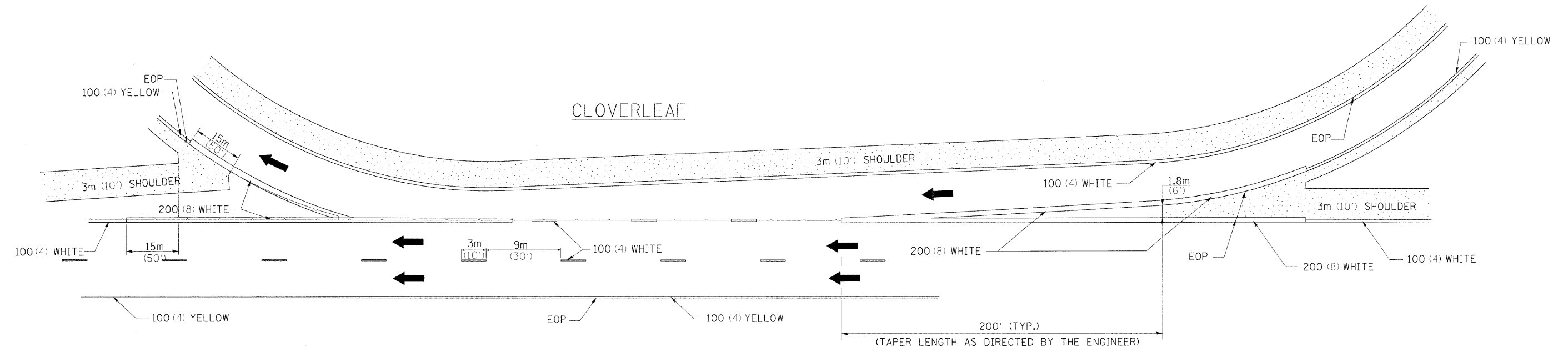

PLOT DATE = 8/24/85
 FILE NAME = 8FLEL8
 PLOT SCALE = 8/32A
 REFERENCE = 8/24/85

F.A. RTE.	SECTION	COUNTY	TOTAL SHEETS	SHEET NO.
308	1 (WB, WB-1, WB, WB-2) R	ROCK ISLAND	210	83
STA.		TO STA.		
FED. ROAD DIST. NO.		ILLINOIS FED. AID PROJECT		

FINAL SURVEY NO. _____
 SURVEYED BY _____
 DATE _____
 SURVEYED BY _____
 DATE _____
 SURVEYED BY _____
 DATE _____

ORIGINAL SURVEY NO. _____
 SURVEYED BY _____
 DATE _____
 SURVEYED BY _____
 DATE _____
 SURVEYED BY _____
 DATE _____

PLOT DATE = *DATE*
 FILE NAME = *FILE*
 PLOT SCALE = *SCALE*
 USER NAME = *USER*

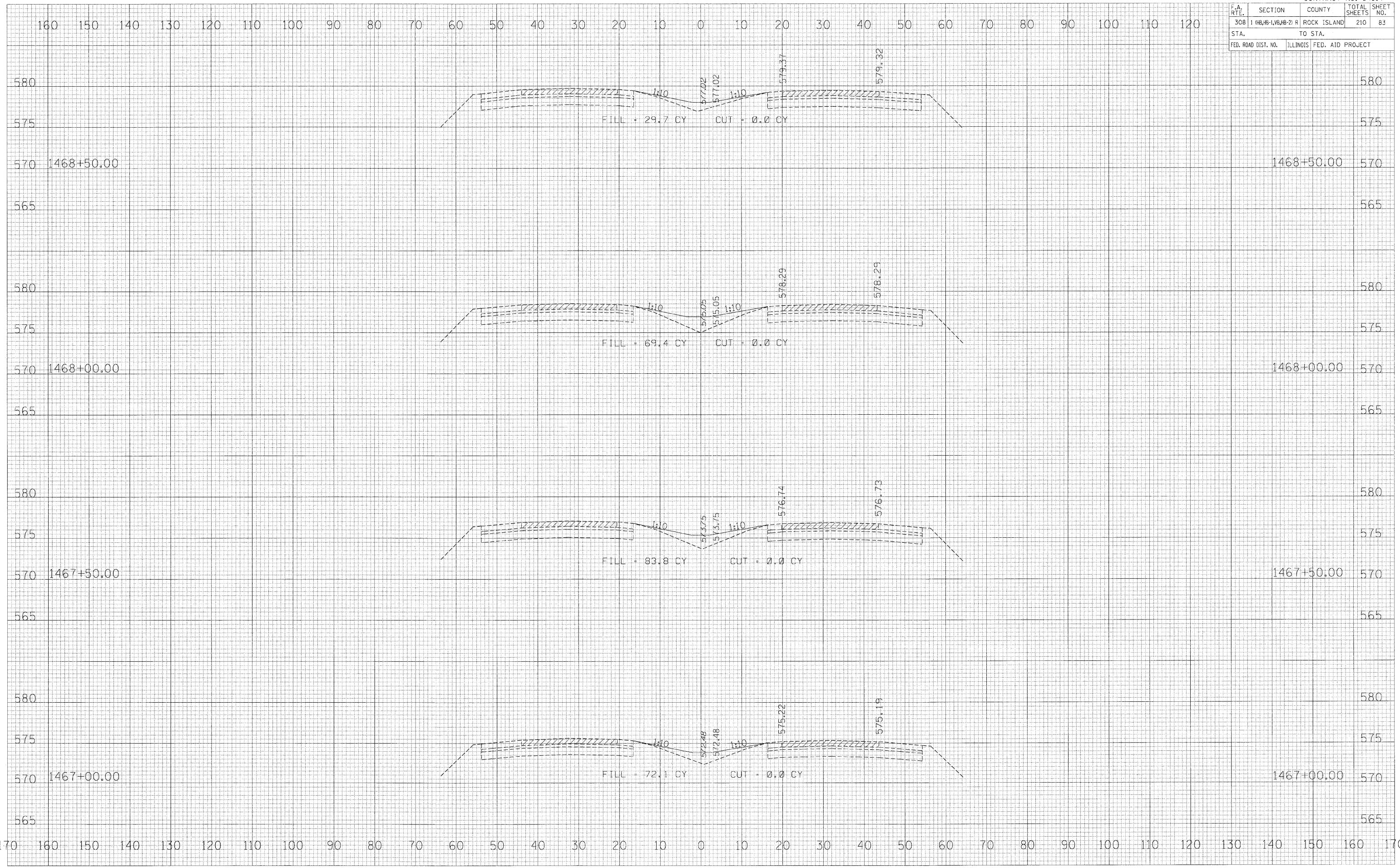

70 160 150 140 130 120 110 100 90 80 70 60 50 40 30 20 10 0 10 20 30 40 50 60 70 80 90 100 110 120 130 140 150 160 170

F.A. RTE.	SECTION	COUNTY	TOTAL SHEETS	SHEET NO.
308	1 @ 64814-1 @ 64814-2 R	ROCK ISLAND	210	84
STA.		TO STA.		
FED. ROAD DIST. NO. 2		ILLINOIS FED. AID PROJECT		

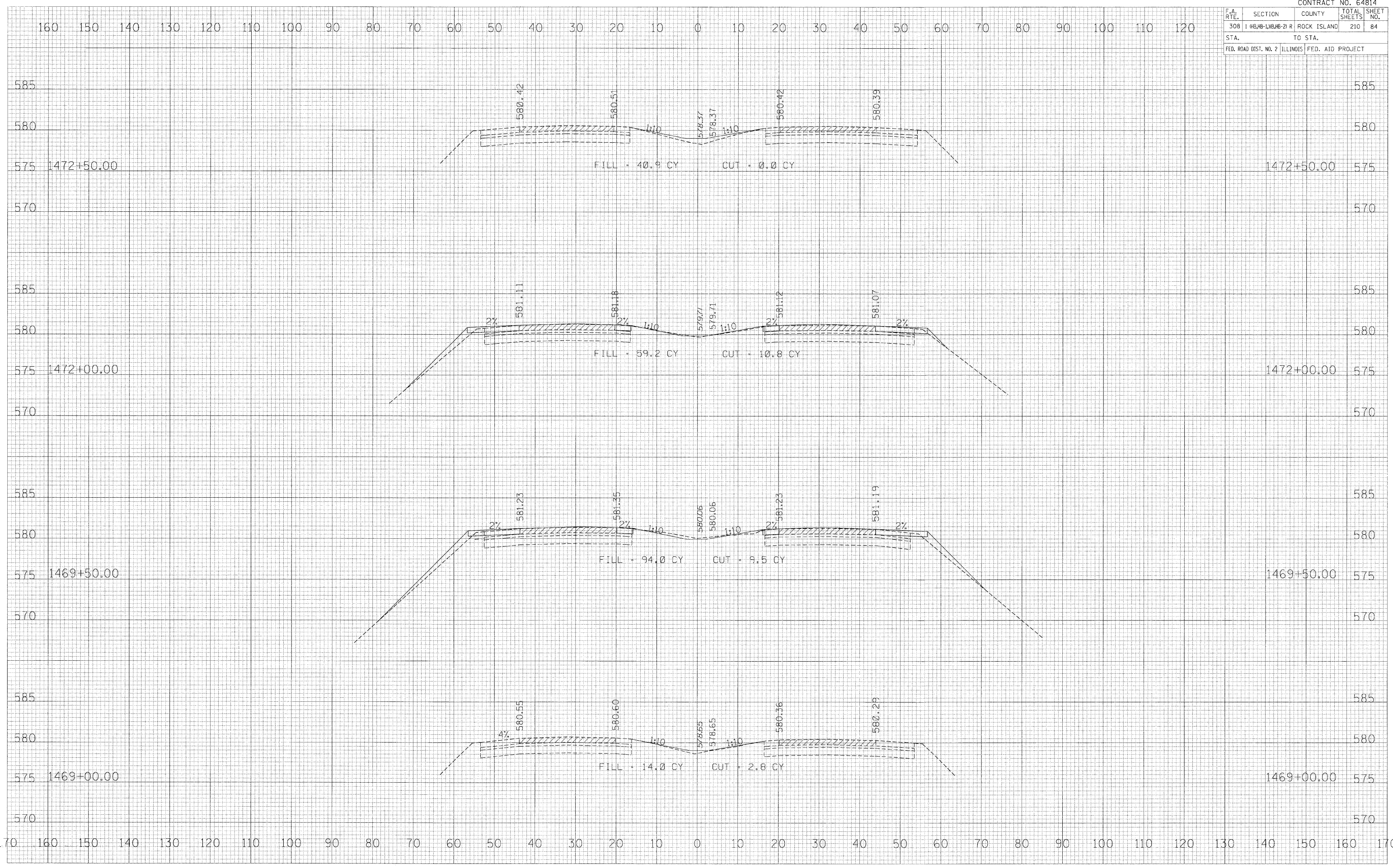

FINAL SURVEY BY DATE
 SURVEYED BY DATE
 TEMPLATE NO. DATE
 NOTE BOOK NO. DATE
 AREAS CHECKED

ORIGINAL SURVEY BY DATE
 SURVEYED BY DATE
 TEMPLATE NO. DATE
 NOTE BOOK NO. DATE
 AREAS CHECKED

PLOT DATE = *DATE*
 FILE NAME = *FILE*
 PLOT SCALE = *SCALE*
 USER NAME = *USER*

F.A. RTE.	SECTION	COUNTY	TOTAL SHEETS	SHEET NO.
308	I 08J4B-1,VB,4B-2I R	ROCK ISLAND	210	64A
STA.		TO STA.		
FED. ROAD DIST. NO.		ILLINOIS FED. AID PROJECT		

FINAL SURVEY	DATE
SURVEYED	BY
NOTE BOOK	
NO.	
TEMP. FILE	
AREAS CHECKED	

ORIGINAL SURVEY	DATE
SURVEYED	BY
NOTE BOOK	
NO.	
TEMP. FILE	
AREAS CHECKED	

PLOT DATE = 04/18/88
 FILE NAME = #FILES#
 PLOT SCALE = #SCALE#
 USER NAME = #USER#

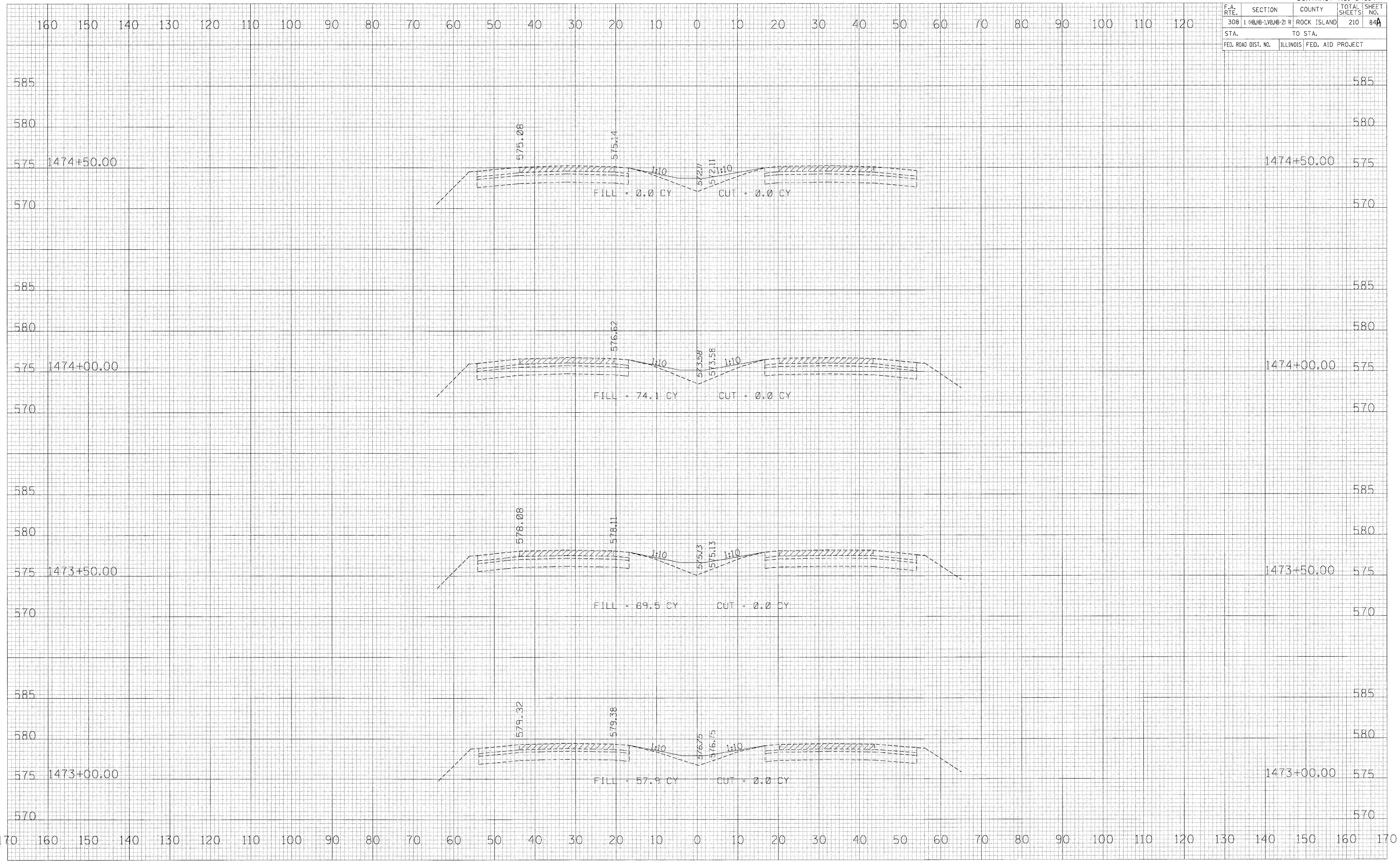

70 160 150 140 130 120 110 100 90 80 70 60 50 40 30 20 10 0 10 20 30 40 50 60 70 80 90 100 110 120 130 140 150 160 170

F.A. RTE.	SECTION	COUNTY	TOTAL SHEETS	SHEET NO.
308	1 08JMB-1,08JMB-2 R	ROCK ISLAND	210	848
STA.		TO STA.		
FED. ROAD DIST. NO. 2		ILLINOIS FED. AID PROJECT		

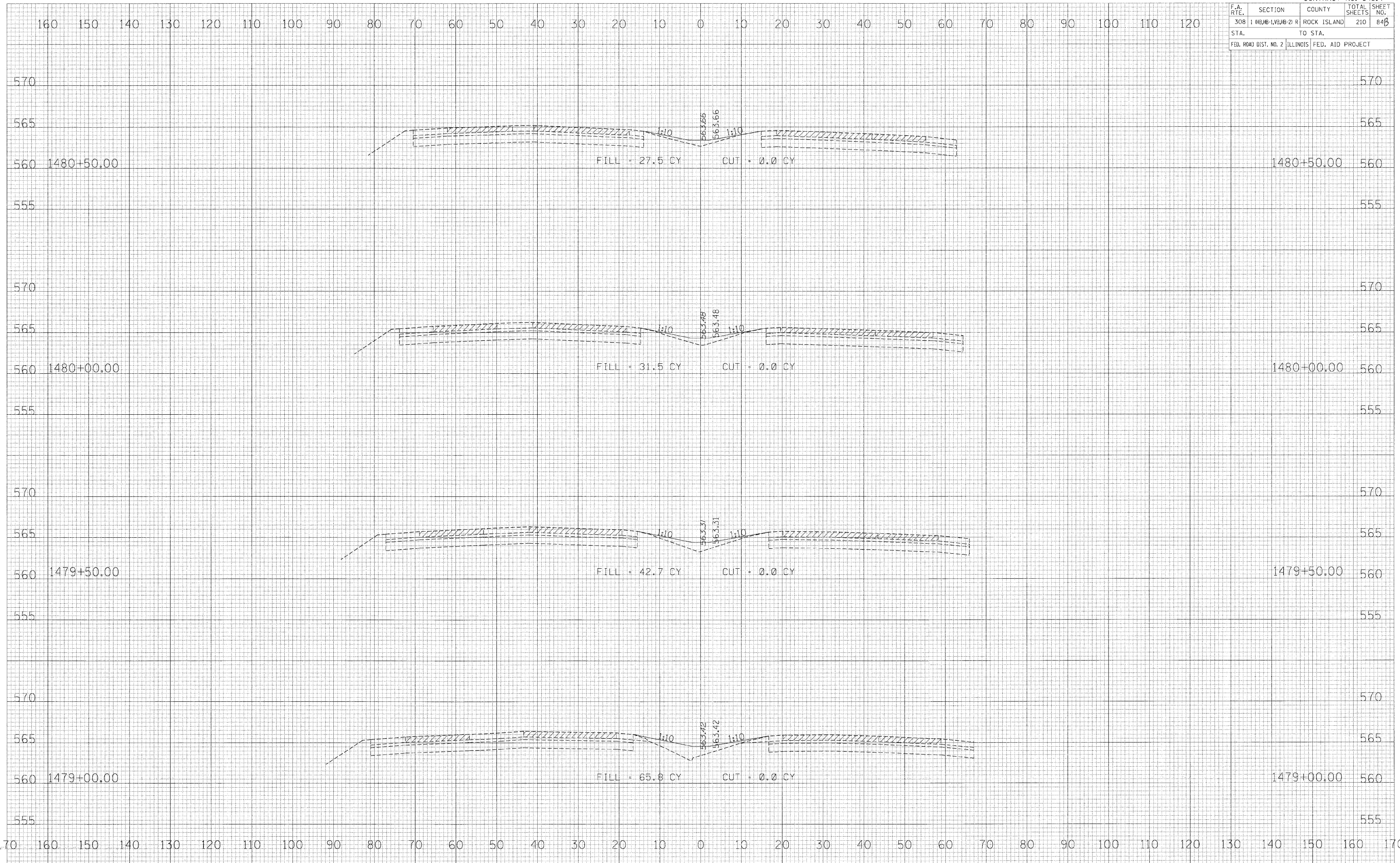

FINAL SURVEY
 SURVEYED _____
 NOTE BOOK _____
 TEMPLATE _____
 AREAS _____
 AREAS CHECKED _____
 BY _____
 DATE _____

ORIGINAL SURVEY
 SURVEYED _____
 NOTE BOOK _____
 TEMPLATE _____
 AREAS _____
 AREAS CHECKED _____
 BY _____
 DATE _____

PLOT DATE = 04/15/15
 FILE NAME = 041515
 PLOT SCALE = 0.5"=1'-0"
 USER NAME = MUSER

F.A. RTE.	SECTION	COUNTY	TOTAL SHEETS	SHEET NO.
308	1 (WB)B-1, WB)B-2) R	ROCK ISLAND	210	84C
STA. TO STA.				
FED. ROAD DIST. NO. ILLINOIS FED. AID PROJECT				

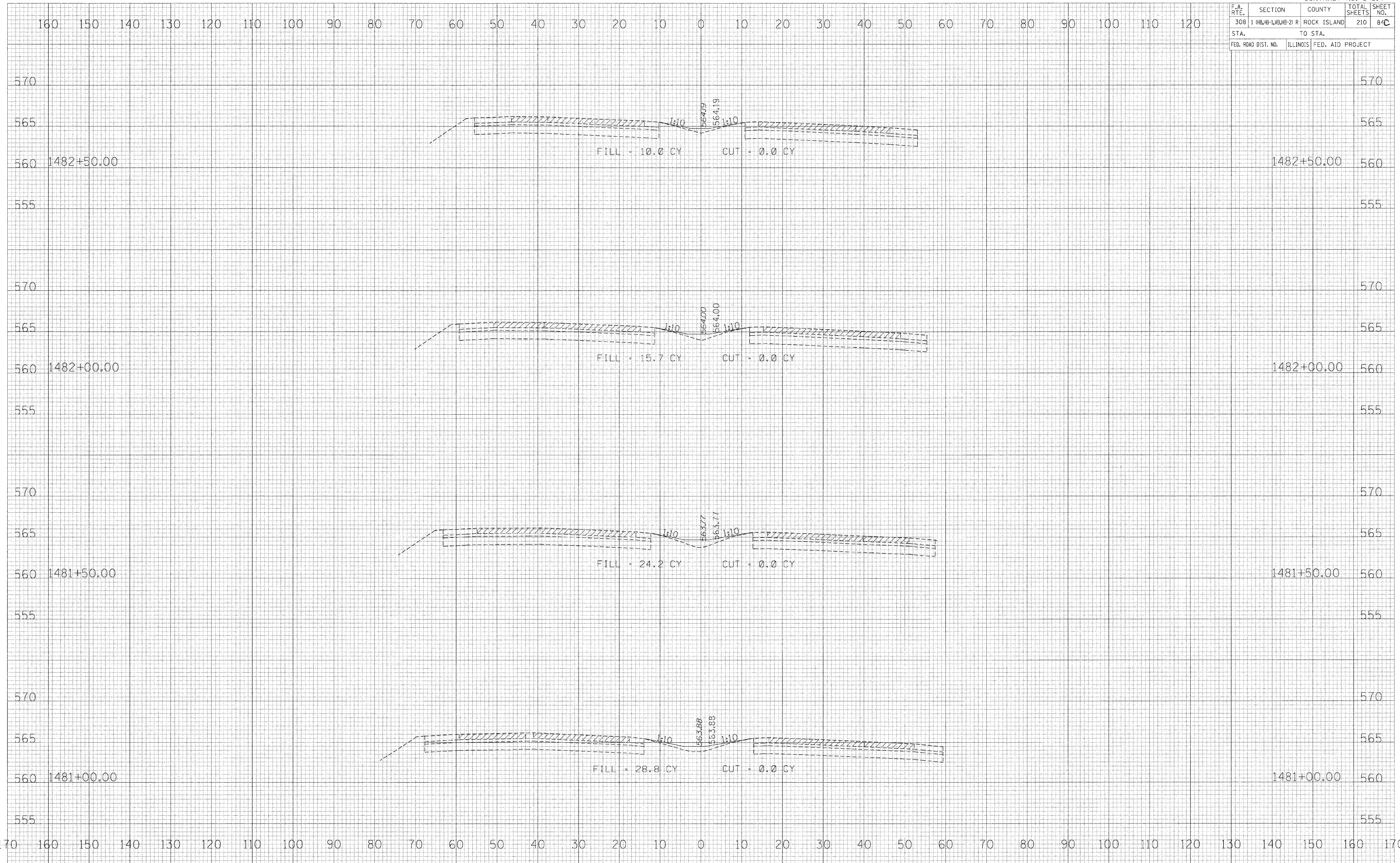

DATE _____
 BY _____
 SURVEYED _____
 TEMPLATE _____
 AREAS CHECKED _____
 NO. _____

DATE _____
 BY _____
 SURVEYED _____
 TEMPLATE _____
 AREAS CHECKED _____
 NO. _____

PLOT DATE = 4/11/83
 FILE NAME = 814E13
 PLOT SCALE = 8/324E13
 USER NAME = 814E13

F.A. RTE.	SECTION	COUNTY	TOTAL SHEETS	SHEET NO.
308	1 065+00-1.00-21 R	ROCK ISLAND	210	84D
STA. TO STA.		FED. AID PROJECT		

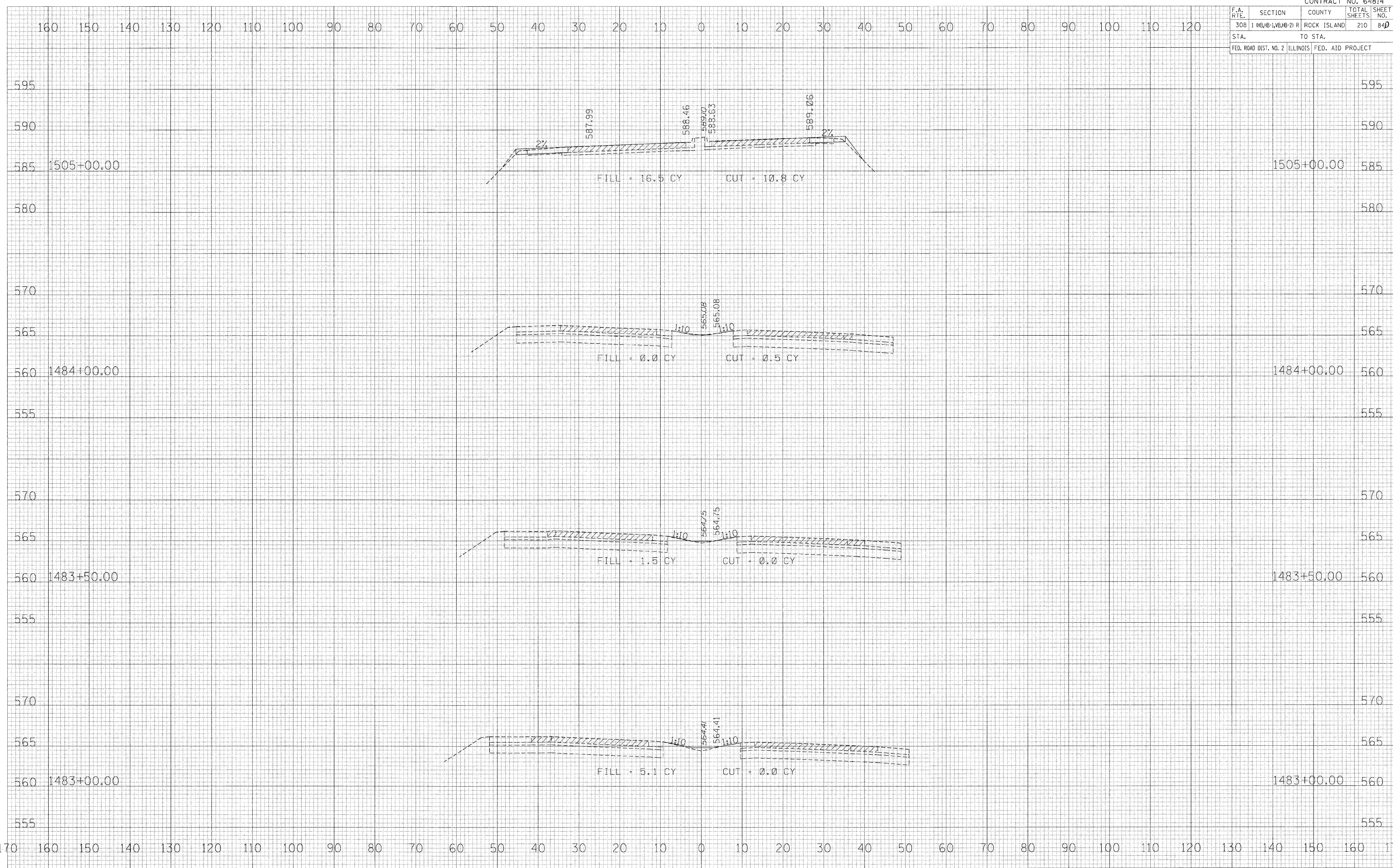

FINAL SURVEY NO. _____ DATE _____
 SURVEYED BY _____
 TEMPLATE NO. _____
 AREAS CHECKED _____

ORIGINAL SURVEY NO. _____ DATE _____
 SURVEYED BY _____
 TEMPLATE NO. _____
 AREAS CHECKED _____

PLT DATE = *DATES*
 FILE NAME = *FILES*
 PLOT SCALE = *SCALES*
 USER NAME = *USERS*

F.A. RTE.	SECTION	COUNTY	TOTAL SHEETS	SHEET NO.
308	1 (WB)B-1, WB)B-2 R	ROCK ISLAND	210	84E
STA.		TO STA.		
FED. ROAD DIST. NO.		ILLINOIS FED. AID PROJECT		

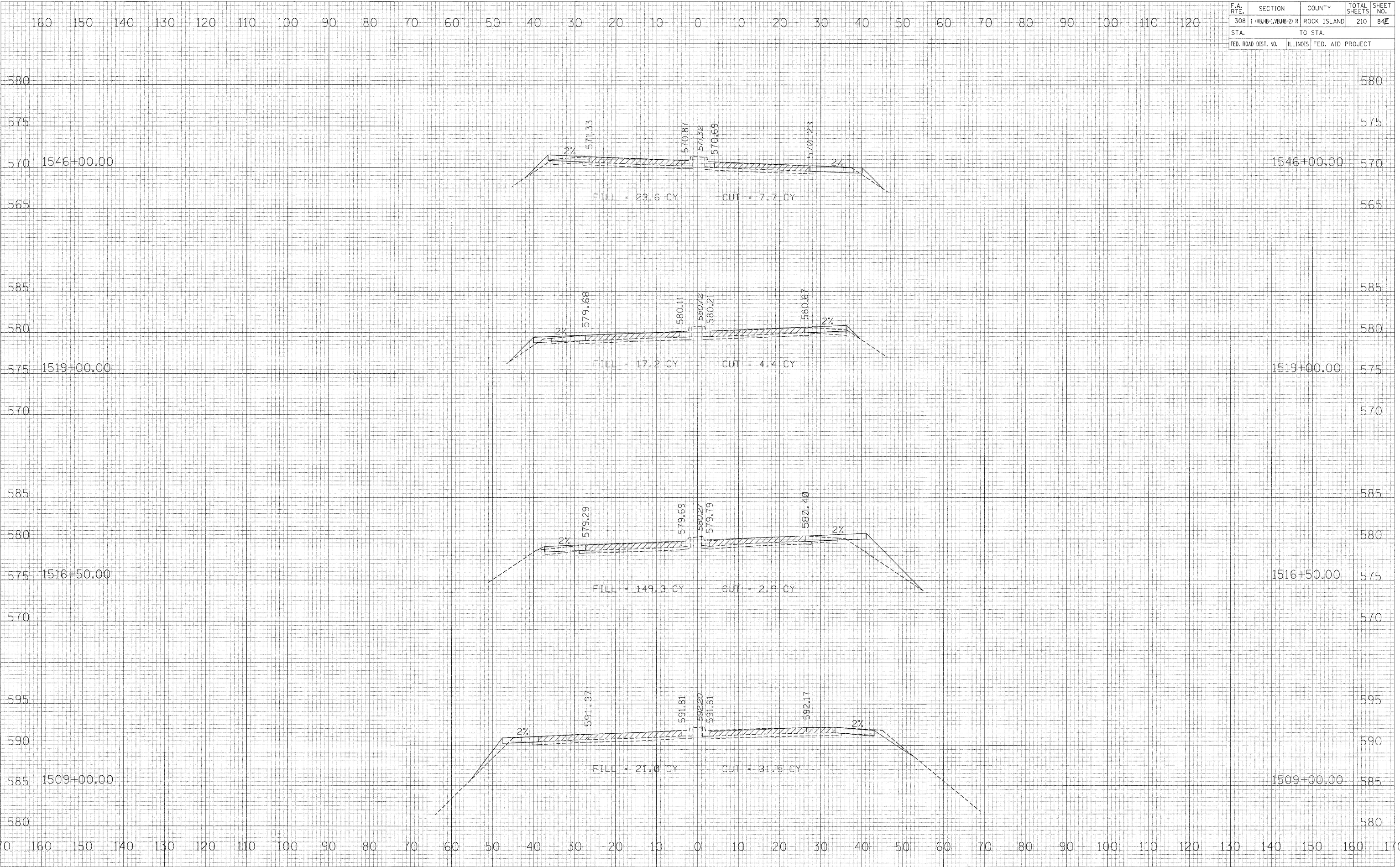

FINAL SURVEY	BY	DATE
NOTE BOOK		
AREAS CHECKED		
NO.		

ORIGINAL SURVEY	BY	DATE
NOTE BOOK		
AREAS CHECKED		
NO.		

PLOT DATE = #D#M#Y
 FILE NAME = #F#L#L#
 PLOT SCALE = #S#C#A#L#
 USER NAME = #U#S#E#R#

F.A. RTE.	SECTION	COUNTY	TOTAL SHEETS	SHEET NO.
308	1 08/18-1/18/18-21 R	ROCK ISLAND	210	84F
STA.		TO STA.		
FED. ROAD DIST. NO. 2		ILLINOIS FED. AID PROJECT		

160 150 140 130 120 110 100 90 80 70 60 50 40 30 20 10 0 10 20 30 40 50 60 70 80 90 100 110 120

DATE	
BY	
SURVEYED	
TEMPLATE	
AREAS	
AREAS CHECKED	
FINAL SURVEY	
NOTE BOOK	
NO.	

DATE	
BY	
SURVEYED	
TEMPLATE	
AREAS	
AREAS CHECKED	
ORIGINAL SURVEY	
NOTE BOOK	
NO.	

PLOT DATE = 04/11/88
 FILE NAME = 871E118
 PLOT SCALE = 83.458
 USER NAME = BUSER88

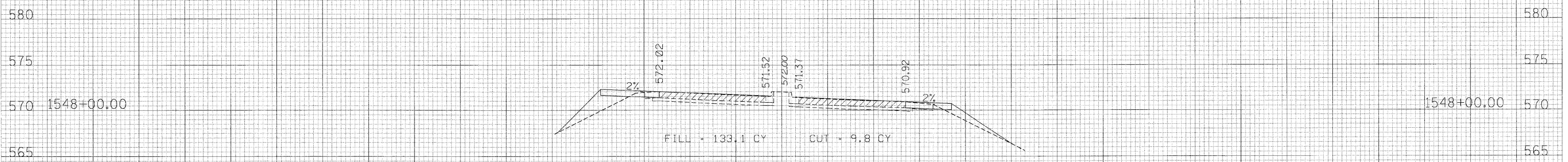

70 160 150 140 130 120 110 100 90 80 70 60 50 40 30 20 10 0 10 20 30 40 50 60 70 80 90 100 110 120 130 140 150 160 170

STATE OF ILLINOIS
DEPARTMENT OF TRANSPORTATION

ROUTE NO.	SECTION	COUNTY	TOTAL SHEETS	SHEET NO.	SHEET NO. 1
F.A.P. 308	*	ROCK ISLAND	210	85	31 SHEETS
FED. ROAD DIST. NO. 7 ILLINOIS FED. AID PROJECT-					
Contract #64814 * (1HB,HB-1,VB,HB-2)R					

Bench Mark: B.M. #494 - Chiseled square on top of Southwest wingwall Sta. 1470+12, 52' Lt. of IL-92, Elev. 583.66

Existing Structure: S.N. 081-0065 (SB) and S.N. 081-0066 (NB), Built as F.A. Route 199, Sec. 1-HB-2 in 1963. Each Structure is three span, 140'-2" back to back of abutments, 36'-0" out to out, typical. Superstructure consists of R.C. deck on WF beams supported on double hammerhead piers and spill-through abutments. Structures to be removed and replaced. Traffic to be maintained utilizing crossovers.

No Salvage

Traffic Barrier Terminal
Std. 631031 - Type 6 (NB)
Std. 631026 - Type 5 (SB W. Parapet)

Traffic Barrier Terminal
Std. 631031 - Type 6 (SB)
Std. 631026 - Type 5 (NB E. Parapet)

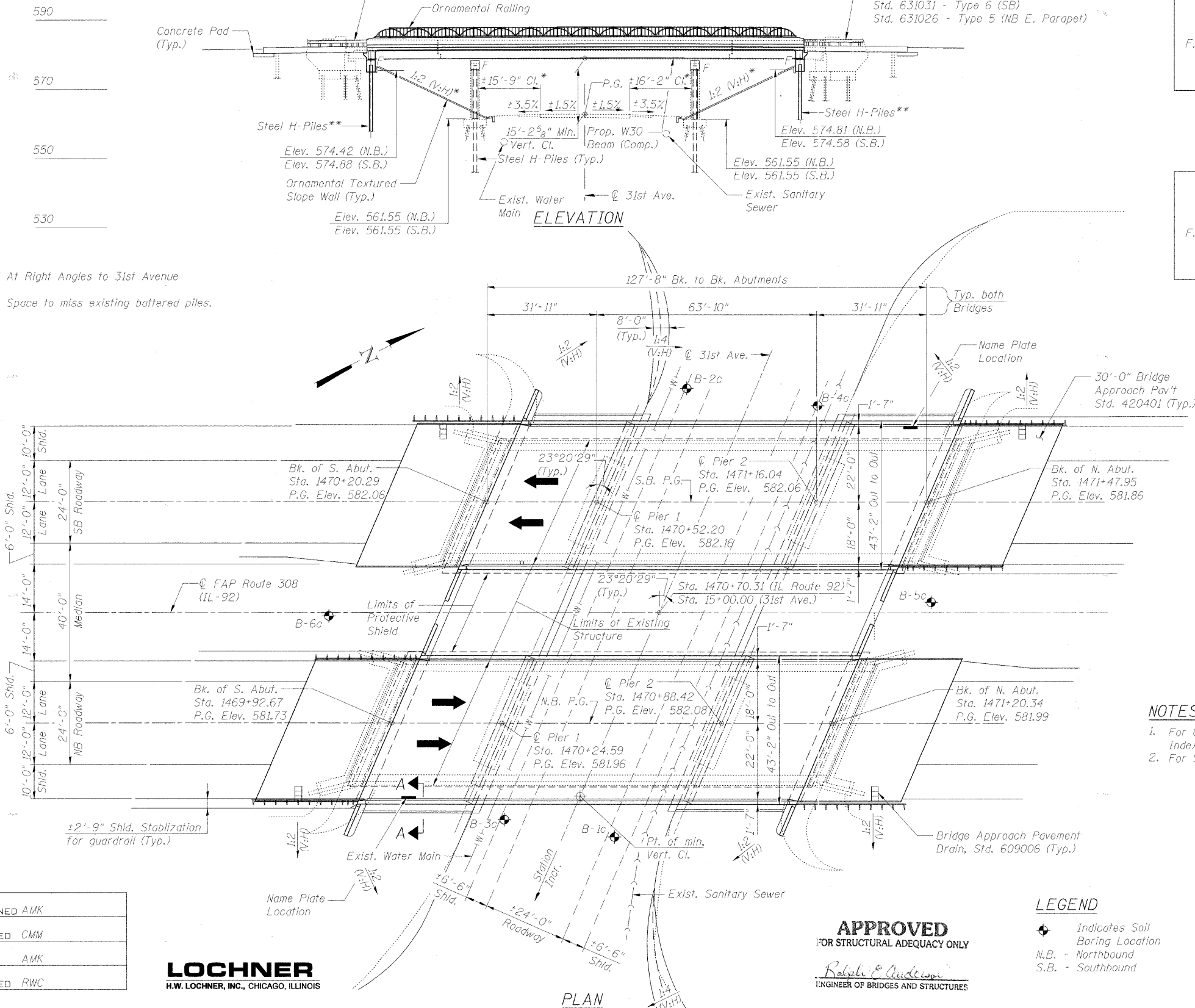

* At Right Angles to 31st Avenue
** Space to miss existing battered piles.

STATION 1470+70.31
BUILT 20__ BY
STATE OF ILLINOIS
F.A. ROUTE 308 SEC. 1(HB-2)R
LOADING HS20
STRUCTURE NO. 081-0172

NAME PLATE
(S.B. Bridge)
Refer to Std. 515001

STATION 1470+70.31
BUILT 20__ BY
STATE OF ILLINOIS
F.A. ROUTE 308 SEC. 1(HB-2)R
LOADING HS20
STRUCTURE NO. 081-0173

NAME PLATE
(N.B. Bridge)
Refer to Std. 515001

LOADING HS20-44
Allow 50#/sq. ft. for Future Wearing Surface.

DESIGN SPECIFICATIONS
2002 AASHTO - 17th Edition

DESIGN STRESSES
FIELD UNITS
f_c = 3,500 psi
f_y = 60,000 psi (reinforcement)
f_y = 50,000 psi (Struct. Steel) (M270 Grade 50)

SEISMIC DATA
Seismic Performance Category (SPC) = A
Bedrock Acceleration Coefficient (A) = 0.034g
Site Coefficient (S) = 1.0

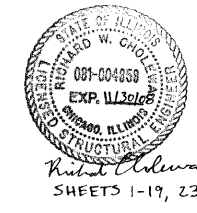
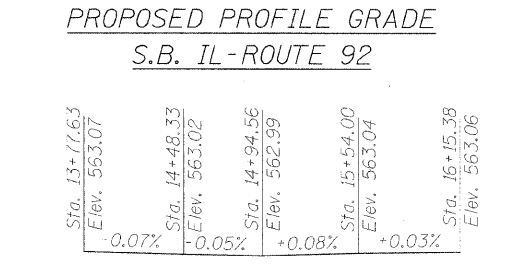
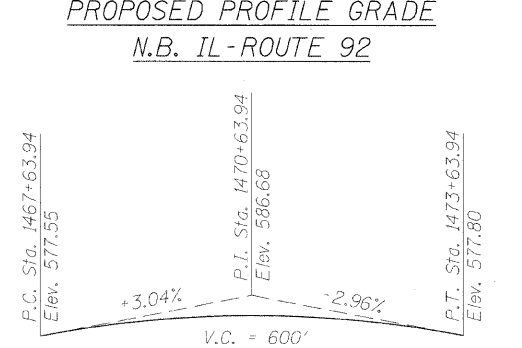
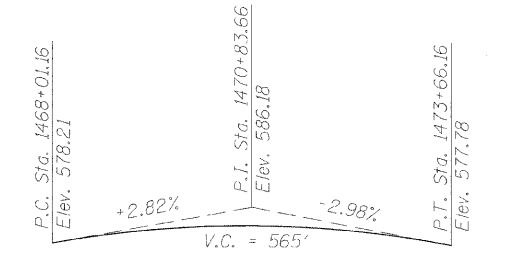

12/5/07
J.D. Galinsky
Exp 11/30/08
SHEETS 20, 21, 22

- NOTES**
- For General Notes, Bill of Materials and Index of Sheets see Sheet No. 2
 - For Section A-A see Sheet No. 3

LEGEND

- Indicates Soil Boring Location
- N.B. - Northbound
- S.B. - Southbound

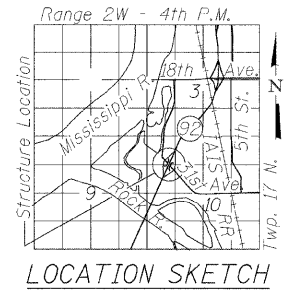

GENERAL PLAN AND ELEVATION
IL ROUTE 92 (CENTENNIAL EXPRESSWAY)
OVER 31st AVENUE
FAP ROUTE 308 SEC. 1(HB-2)R
ROCK ISLAND COUNTY
STATION 1470+70.31
STRUCTURE NO. 081-0172 (SB)
STRUCTURE NO. 081-0173 (NB)

DESIGNED	AMK
CHECKED	CMM
DRAWN	AMK
CHECKED	RWC

LOCHNER
H.W. LOCHNER, INC., CHICAGO, ILLINOIS

APPROVED
FOR STRUCTURAL ADEQUACY ONLY
Robert E. Anderson
ENGINEER OF BRIDGES AND STRUCTURES

STATE OF ILLINOIS
DEPARTMENT OF TRANSPORTATION

ROUTE NO.	SECTION	COUNTY	TOTAL SHEETS	SHEET NO.	SHEET NO. 2
F.A.P. 308	#	ROCK ISLAND	210	86	31 SHEETS
FED. ROAD DIST. NO. 7	ILLINOIS	FED. AID PROJECT	Contract #64814 * (1HB,HB-1,VB,HB-2)R		

GENERAL NOTES

- Fasteners shall be AASHTO M164 Type 1, mechanically galvanized bolts. Bolts $\frac{7}{8}$ in. dia., holes $\frac{15}{16}$ in. dia., unless otherwise noted.
- Calculated weight of Structural Steel M270 Grade 36 = 26,020 lbs.
Calculated weight of Structural Steel M270 Grade 50 = 159,700 lbs.
- No field welding is permitted except as specified in the contract documents.
- Reinforcement bars shall conform to the requirements of ASTM A 706 Gr 60 (IL Modified). See Special Provisions.
- Reinforcement bars designated (E) shall be epoxy coated.
- Bearing seat surfaces shall be constructed or adjusted to their designated elevations within a tolerance of $\frac{1}{8}$ inch (0.01 ft.). Adjustment shall be made either by grinding the surface or by shimming the bearings.
- Concrete Sealer shall be applied to the designated areas of the Piers.
- The existing structural steel coating contains lead. The Contractor shall take appropriate precautions to deal with the presence of lead on this project.
- The Organic Zinc Rich Primer / Epoxy / Urethane Paint System shall be used for painting of new structural steel except where otherwise noted. The entire system shall be shop applied, with the exception that masked off connection surfaces, field installed fasteners and damaged areas shall be touched up in the field. The color of the final finish coat for all interior steel surfaces shall be Gray, Munsell No. 5B 7/1. The color of the final finish coat for the exterior and bottom flange of the fascia beams shall be Blue, Munsell No. 10B 3/6. See Special Provision for "Cleaning and Painting New Metal Structures".
- In lieu of the hammer selection criteria and use of the FHWA Modified Gates formula specified in Section 512 of the Standard Specifications, the Contractor shall conduct a wave equation analysis to establish the driving criteria at all pile foundations which specify a nominal required bearing above 600 kips. The analysis and calculations shall be submitted to the Engineer for approval.
- Slip forming of the parapets is not allowed.
- See Electrical Plans for Bridge Underpass Lighting details.
- All concrete for "Concrete Structures" in the area of the Form Liner Limestone Surface shall be Self-Consolidating Concrete. See Special Provisions for "Self-Consolidating Concrete for Cast-in-Place Construction."

TOTAL BILL OF MATERIAL

Item	Unit	Super	Sub		Total
			Piers	Abuts.	
Porous Granular Embankment, Special	Cu. Yd.			276	276
Removal of Existing Structures No. 3	Each	2			2
Protective Shield	Sq. Yd.	1,104			1,104
Structure Excavation	Cu. Yd.		80	160	240
Concrete Structures	Cu. Yd.		327.5	82.4	409.9
Rubbed Finish	Sq. Ft.		3,400		3,400
Concrete Superstructure	Cu. Yd.	103.8			403.8
Bridge Deck Grooving	Sq. Yd.	1,079			1,079
Concrete Encasement	Cu. Yd.		19.6	11.2	30.8
Protective Coat	Sq. Yd.	1,349			1,349
Furnishing and Erecting Structural Steel	L. Sum	0.3			0.3
Stud Shear Connectors	Each	3,744			3,744
Reinforcement Bars, Epoxy Coated	Pound	88,620	19,990	13,370	121,980
Bar Splicers	Each	160			160
Furnishing Steel Piles HPI2x53	Foot			1,952	1,952
Furnishing Steel Piles HPI4x89	Foot		2,304		2,304
Driving Piles	Foot		2,304	1,952	4,256
Pile Shoes	Each		36	32	68
Name Plates	Each	2			2
Anchor Bolts, 1"	Each		48	48	96
Concrete Sealer	Sq. Ft.		6,490		6,490
Geocomposite Wall Drain	Sq. Yd.			171	171
Pipe Underdrains for Structures 4"	Foot			340	340
Textured Slope Wall	Sq. Yd.			993	993
Form Liner Limestone Surface	Sq. Ft.		2,913		2,913
Ornamental Railing	Foot	482			482

INDEX OF SHEETS

SHEET NO.	TITLE
1	GENERAL PLAN AND ELEVATION
2	GENERAL NOTES, BILL OF MATERIAL AND INDEX OF SHEETS
3	FOOTING LAYOUT
4	STAGING DETAILS
5	TOP OF SLAB ELEVATIONS (SB)
6	TOP OF SLAB ELEVATIONS (NB)
7	TOP OF NORTH AND SOUTH APPROACH SLAB ELEVATIONS (SB)
8	TOP OF NORTH AND SOUTH APPROACH SLAB ELEVATIONS (NB)
9	DECK PLAN
10	INTEGRAL ABUTMENT DIAPHRAGM DETAILS
11	PARAPET DETAILS
12	ORNAMENTAL RAILING DETAILS
13	FRAMING PLAN
14	STEEL DETAILS 1
15	STEEL DETAILS 2
16	SOUTH ABUTMENT (SB)
17	SOUTH ABUTMENT (NB)
18	NORTH ABUTMENT (SB)
19	NORTH ABUTMENT (NB)
20	PIERS 1 AND 2 (SB)
21	PIERS 1 AND 2 (NB)
22	STEEL PILE DETAILS
23	BAR SPLICER ASSEMBLY DETAILS
24	PIER ENHANCEMENTS
25	TEMPORARY CONCRETE BARRIER FOR STAGE CONSTRUCTION
26	SOIL BORINGS 1
27	SOIL BORINGS 2
28	SOIL BORINGS 3
29	SOIL BORINGS 4
30	SOIL BORINGS 5
31	SOIL BORINGS 6

GENERAL NOTES, BILL OF MATERIAL
AND INDEX OF SHEETS
IL ROUTE 92 (CENTENNIAL EXPRESSWAY)
OVER 31st AVENUE
FAP ROUTE 308 SEC. 1(HB-2)R
ROCK ISLAND COUNTY
STATION 1470+70.31
STR. 081-0172 (SB) STR. NO. 081-0173 (NB)

DESIGNED CMM
CHECKED AMK
DRAWN OS
CHECKED RWC

LOCHNER
H.W. LOCHNER, INC., CHICAGO, ILLINOIS

t: 2082457-uc ttdgn@20440236N1.dgn

STATE OF ILLINOIS
DEPARTMENT OF TRANSPORTATION

ROUTE NO. F.A.P. 308	SECTION *	COUNTY ROCK ISLAND	SHEET NO. 210	SHEET NO. 87	SHEET NO. 3 31 SHEETS
FED. ROAD DIST. NO. 7		ILLINOIS FED. AID PROJECT		Contract #64814 * (1HB,HB-1,VB,HB-2)R	

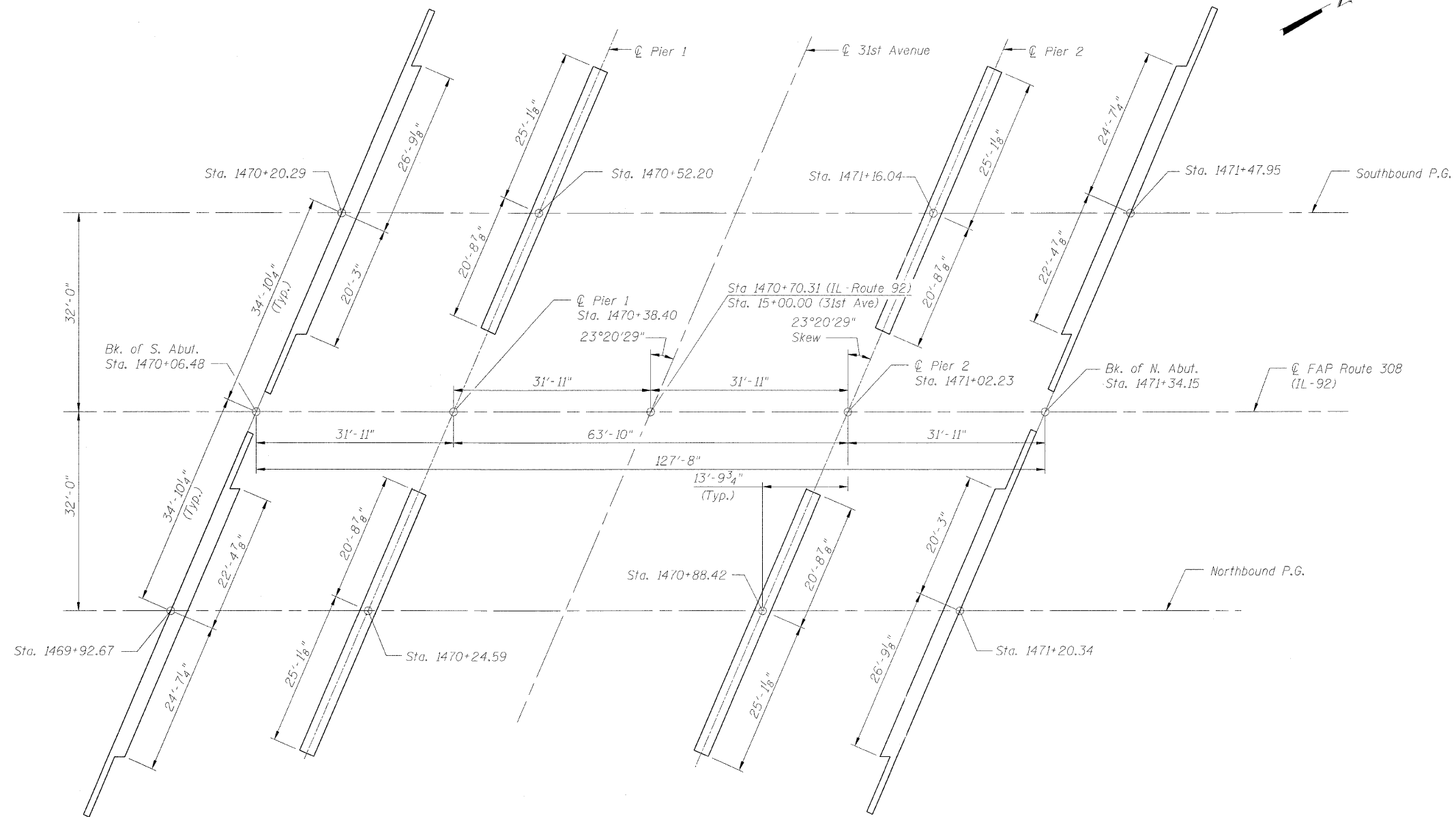

FOOTING LAYOUT

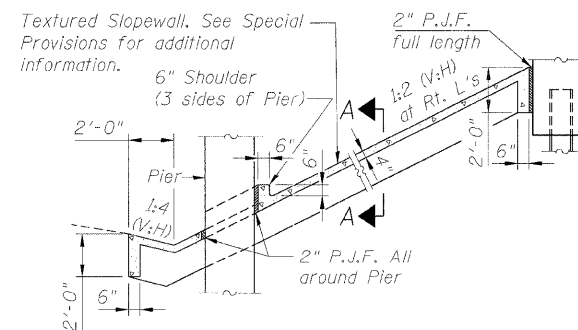

SECTION THRU SLOPEWALL

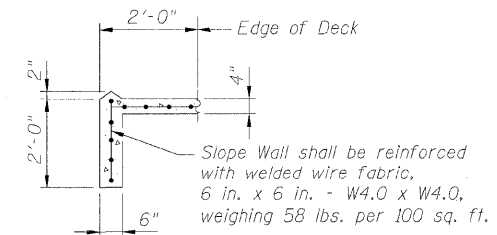

SECTION A-A

FOOTING LAYOUT
IL ROUTE 92 (CENTENNIAL EXPRESSWAY)
OVER 31st AVENUE
FAP ROUTE 308 SEC. 1(HB-2)R
ROCK ISLAND COUNTY
STATION 1470+70.31
STRUCTURE NO. 081-0172 (SB)
STRUCTURE NO. 081-0173 (NB)

DESIGNED	AMK
CHECKED	CMM
DRAWN	OS
CHECKED	RWC

LOCHNER
H.W. LOCHNER, INC., CHICAGO, ILLINOIS

t:\2082\struc\set\sgn\20440231A1.dgn

STATE OF ILLINOIS
DEPARTMENT OF TRANSPORTATION

ROUTE NO. F.A.P. 308	SECTION #	COUNTY ROCK ISLAND	TOTAL SHEETS 210	SHEET NO. 88	SHEET NO. 4 31 SHEETS
FED. ROAD DIST. NO. 1		ILLINOIS		FED. AID PROJECT	
Contract #64814			* 1(HB,HB-1,VB,HB-2)R		

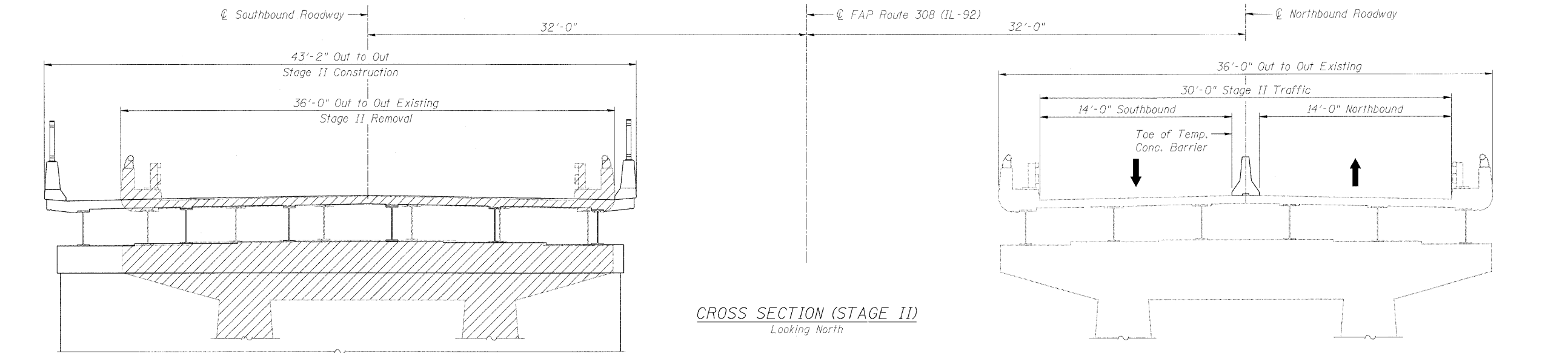

CROSS SECTION (STAGE II)
Looking North

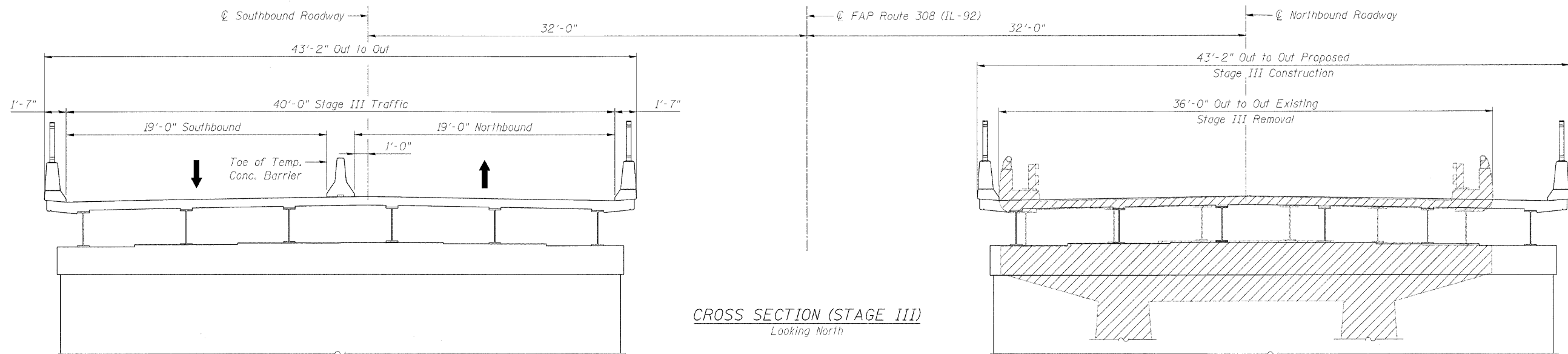

CROSS SECTION (STAGE III)
Looking North

LEGEND

 Indicates Removal of Existing Structures

DESIGNED	AMK
CHECKED	BJN
DRAWN	OS
CHECKED	RWC

LOCHNER
H.W. LOCHNER, INC., CHICAGO, ILLINOIS

STAGING DETAILS
IL ROUTE 92 (CENTENNIAL EXPRESSWAY)
OVER 31st AVENUE
FAP ROUTE 308 SEC. 1(HB-2)R
ROCK ISLAND COUNTY
STATION 1470+70.31
STRUCTURE NO. 081-0172 (SB)
STRUCTURE NO. 081-0173 (NB)

t:\2002\st-ue\tdgn\2044023561.dgn

STATE OF ILLINOIS
DEPARTMENT OF TRANSPORTATION

Contract #64814 * (IHB, HB-1, VB, HB-2)R

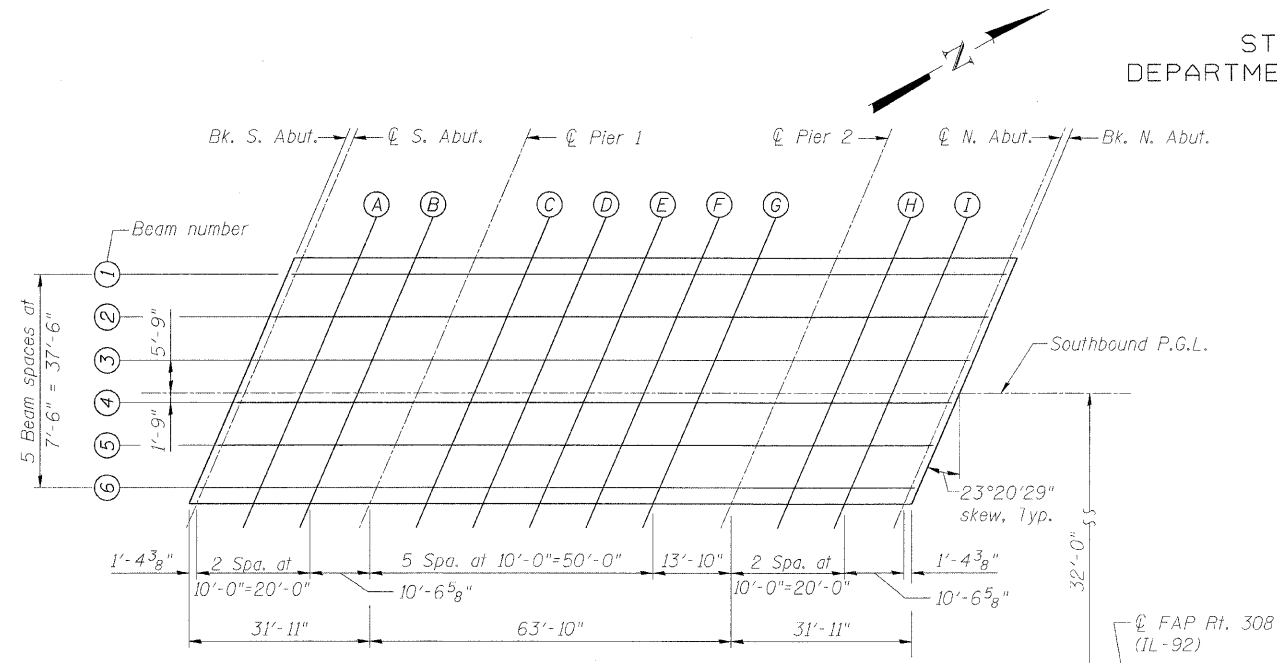

PLAN
(S.B. Structure)

BEAM 1

Location	Station	Offset*	Theoretical Grade Elevations	Theoretical Grade Elevations Adjusted For Dead Load Deflection
Bk. S. Abut.	1470+29.24	-20.75	581.74	581.74
CL S. Abut.	1470+30.61	-20.75	581.74	581.74
A	1470+40.61	-20.75	581.77	581.77
B	1470+50.61	-20.75	581.80	581.79
CL Pier 1	1470+61.15	-20.75	581.81	581.81
C	1470+71.15	-20.75	581.81	581.84
D	1470+81.15	-20.75	581.80	581.86
E	1470+91.15	-20.75	581.78	581.86
F	1471+01.15	-20.75	581.76	581.82
G	1471+11.15	-20.75	581.72	581.76
CL Pier 2	1471+24.99	-20.75	581.65	581.65
H	1471+34.99	-20.75	581.59	581.58
I	1471+44.99	-20.75	581.51	581.51
CL N. Abut.	1471+55.54	-20.75	581.43	581.43
Bk. N. Abut.	1471+56.90	-20.75	581.42	581.42

BEAM 2

Location	Station	Offset*	Theoretical Grade Elevations	Theoretical Grade Elevations Adjusted For Dead Load Deflection
Bk. S. Abut.	1470+26.01	-13.25	581.88	581.88
CL S. Abut.	1470+27.37	-13.25	581.88	581.88
A	1470+37.37	-13.25	581.92	581.92
B	1470+47.37	-13.25	581.95	581.94
CL Pier 1	1470+57.92	-13.25	581.96	581.96
C	1470+67.92	-13.25	581.97	582.00
D	1470+77.92	-13.25	581.96	582.02
E	1470+87.92	-13.25	581.95	582.02
F	1470+97.92	-13.25	581.92	581.99
G	1471+07.92	-13.25	581.89	581.93
CL Pier 2	1471+21.76	-13.25	581.82	581.82
H	1471+31.76	-13.25	581.76	581.76
I	1471+41.76	-13.25	581.69	581.69
CL N. Abut.	1471+52.31	-13.25	581.61	581.61
Bk. N. Abut.	1471+53.67	-13.25	581.60	581.60

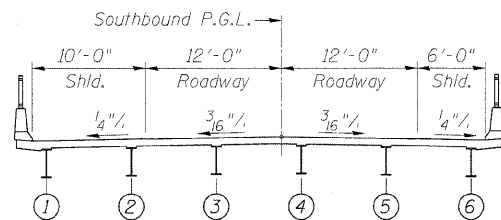

CROSS SECTION
(Looking North)

BEAM 3

Location	Station	Offset*	Theoretical Grade Elevations	Theoretical Grade Elevations Adjusted For Dead Load Deflection
Bk. S. Abut.	1470+22.77	-5.75	581.99	581.99
CL S. Abut.	1470+24.13	-5.75	582.00	582.00
A	1470+34.13	-5.75	582.03	582.03
B	1470+44.13	-5.75	582.06	582.06
CL Pier 1	1470+54.68	-5.75	582.08	582.08
C	1470+64.68	-5.75	582.09	582.12
D	1470+74.68	-5.75	582.09	582.15
E	1470+84.68	-5.75	582.08	582.15
F	1470+94.68	-5.75	582.06	582.12
G	1471+04.68	-5.75	582.02	582.07
CL Pier 2	1471+18.52	-5.75	581.96	581.96
H	1471+28.52	-5.75	581.91	581.90
I	1471+38.52	-5.75	581.84	581.84
CL N. Abut.	1471+49.07	-5.75	581.76	581.76
Bk. N. Abut.	1471+50.43	-5.75	581.75	581.75

SOUTHBOUND P.G.L.

Location	Station	Offset*	Theoretical Grade Elevations	Theoretical Grade Elevations Adjusted For Dead Load Deflection
Bk. S. Abut.	1470+20.29	0.00	582.07	582.07
CL S. Abut.	1470+21.65	0.00	582.07	582.07
A	1470+31.65	0.00	582.11	582.11
B	1470+41.65	0.00	582.15	582.14
CL Pier 1	1470+52.20	0.00	582.17	582.17
C	1470+62.20	0.00	582.18	582.21
D	1470+72.20	0.00	582.18	582.24
E	1470+82.20	0.00	582.17	582.25
F	1470+92.20	0.00	582.15	582.22
G	1471+02.20	0.00	582.12	582.16
CL Pier 2	1471+16.04	0.00	582.07	582.07
H	1471+26.04	0.00	582.01	582.01
I	1471+36.04	0.00	581.95	581.95
CL N. Abut.	1471+46.59	0.00	581.87	581.87
Bk. N. Abut.	1471+47.95	0.00	581.86	581.86

BEAM 4

Location	Station	Offset*	Theoretical Grade Elevations	Theoretical Grade Elevations Adjusted For Dead Load Deflection
Bk. S. Abut.	1470+19.53	1.75	582.04	582.04
CL S. Abut.	1470+20.90	1.75	582.04	582.04
A	1470+30.90	1.75	582.08	582.08
B	1470+40.90	1.75	582.12	582.11
CL Pier 1	1470+51.44	1.75	582.14	582.14
C	1470+61.44	1.75	582.15	582.18
D	1470+71.44	1.75	582.15	582.21
E	1470+81.44	1.75	582.14	582.22
F	1470+91.44	1.75	582.13	582.19
G	1471+01.44	1.75	582.10	582.14
CL Pier 2	1471+15.28	1.75	582.04	582.04
H	1471+25.28	1.75	581.99	581.98
I	1471+35.28	1.75	581.93	581.92
CL N. Abut.	1471+45.83	1.75	581.85	581.85
Bk. N. Abut.	1471+47.19	1.75	581.84	581.84

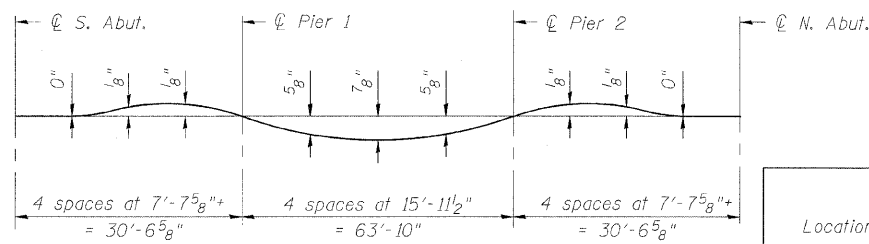

DEAD LOAD DEFLECTION DIAGRAM
(Includes weight of concrete only.)

Note:
The above deflections are not to be used in the field if the engineer is working from the grade elevations adjusted for dead load deflections as shown herein.

DESIGNED	CMM
CHECKED	AMK
DRAWN	EF
CHECKED	RWC

LOCHNER
H.W. LOCHNER, INC., CHICAGO, ILLINOIS

BEAM 5

Location	Station	Offset*	Theoretical Grade Elevations	Theoretical Grade Elevations Adjusted For Dead Load Deflection
Bk. S. Abut.	1470+16.30	9.25	581.90	581.90
CL S. Abut.	1470+17.66	9.25	581.91	581.91
A	1470+27.66	9.25	581.96	581.95
B	1470+37.66	9.25	581.99	581.98
CL Pier 1	1470+48.21	9.25	582.02	582.02
C	1470+58.21	9.25	582.03	582.06
D	1470+68.21	9.25	582.04	582.10
E	1470+78.21	9.25	582.03	582.11
F	1470+88.21	9.25	582.02	582.08
G	1470+98.21	9.25	581.99	582.03
CL Pier 2	1471+12.05	9.25	581.94	581.94
H	1471+22.05	9.25	581.89	581.88
I	1471+32.05	9.25	581.83	581.83
CL N. Abut.	1471+42.60	9.25	581.76	581.76
Bk. N. Abut.	1471+43.96	9.25	581.75	581.75

BEAM 6

Location	Station	Offset*	Theoretical Grade Elevations	Theoretical Grade Elevations Adjusted For Dead Load Deflection
Bk. S. Abut.	1470+13.06	16.75	581.74	581.74
CL S. Abut.	1470+14.42	16.75	581.75	581.75
A	1470+24.42	16.75	581.80	581.80
B	1470+34.42	16.75	581.84	581.83
CL Pier 1	1470+44.97	16.75	581.87	581.87
C	1470+54.97	16.75	581.89	581.92
D	1470+64.97	16.75	581.89	581.95
E	1470+74.97	16.75	581.89	581.97
F	1470+84.97	16.75	581.88	581.95
G	1470+94.97	16.75	581.86	581.90
CL Pier 2	1471+08.81	16.75	581.81	581.81
H	1471+18.81	16.75	581.76	581.76
I	1471+28.81	16.75	581.71	581.71
CL N. Abut.	1471+39.36	16.75	581.64	581.64
Bk. N. Abut.	1471+40.72	16.75	581.63	581.63

* Offsets are taken from Southbound P.G.L.

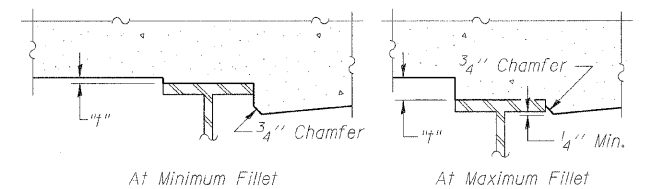

To determine "h": Elevations of the top flanges of the beams shall be taken at intervals shown herein. These elevations subtracted from the "Theoretical Grade Elevations Adjusted for Dead Load Deflection" shown herein, minus slab thickness, equals the fillet heights "h" above top flange of beams.

FILLET HEIGHTS

TOP OF SLAB ELEVATIONS (SB)
IL ROUTE 92 (CENTENNIAL EXPRESSWAY)
OVER 31st AVENUE
FAP ROUTE 308 SEC. (IHB-2)R
ROCK ISLAND COUNTY
STATION 1470+70.31
STRUCTURE NO. 081-0172 (SB)
STRUCTURE NO. 081-0173 (NB)

STATE OF ILLINOIS
DEPARTMENT OF TRANSPORTATION

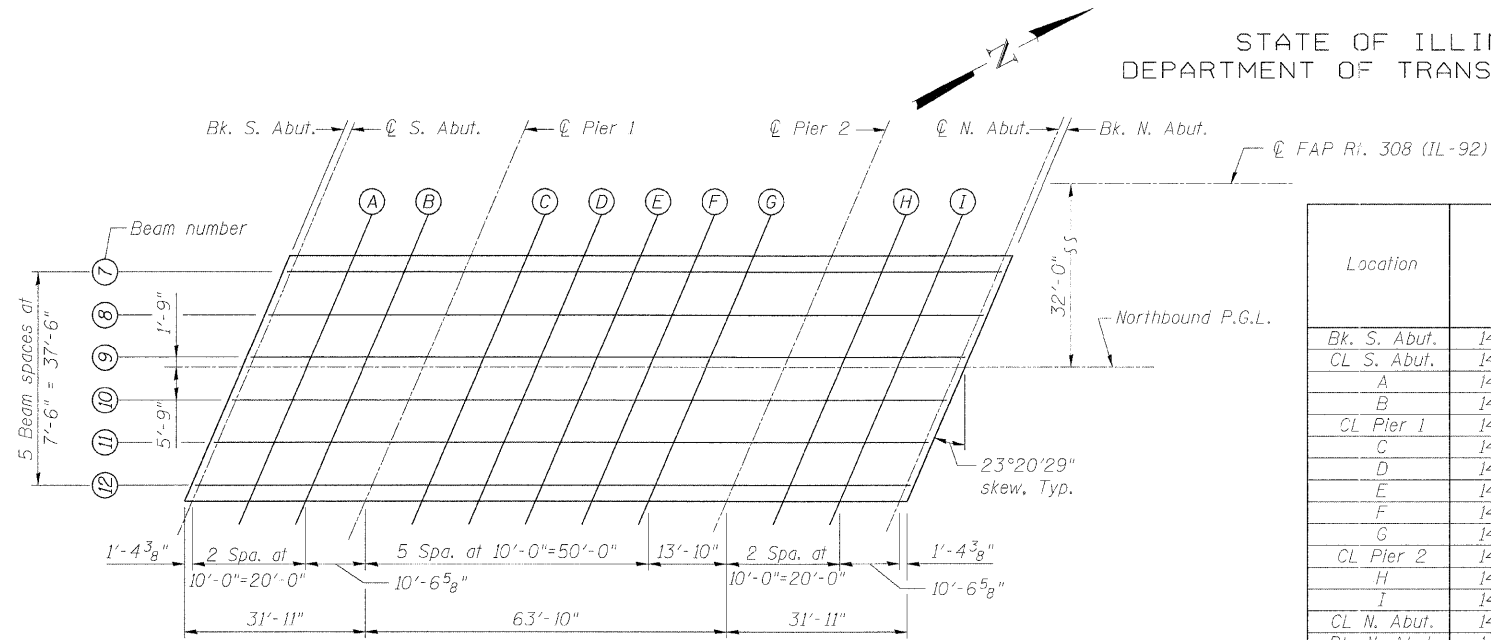

BEAM 7

Location	Station	Offset*	Theoretical Grade Elevations	Theoretical Grade Elevations Adjusted For Dead Load Deflection
Bk. S. Abut.	1469+99.90	-16.75	581.50	581.50
CL S. Abut.	1470+01.26	-16.75	581.51	581.51
A	1470+11.26	-16.75	581.59	581.58
B	1470+21.26	-16.75	581.65	581.64
CL Pier 1	1470+31.82	-16.75	581.70	581.70
C	1470+41.82	-16.75	581.74	581.77
D	1470+51.82	-16.75	581.77	581.83
E	1470+61.82	-16.75	581.79	581.87
F	1470+71.82	-16.75	581.80	581.87
G	1470+81.82	-16.75	581.80	581.84
CL Pier 2	1470+95.65	-16.75	581.78	581.78
H	1471+05.65	-16.75	581.75	581.75
I	1471+15.65	-16.75	581.72	581.72
CL N. Abut.	1471+26.21	-16.75	581.67	581.67
Bk. N. Abut.	1471+27.57	-16.75	581.66	581.66

BEAM 8

Location	Station	Offset*	Theoretical Grade Elevations	Theoretical Grade Elevations Adjusted For Dead Load Deflection
Bk. S. Abut.	1469+96.66	-9.25	581.62	581.62
CL S. Abut.	1469+98.02	-9.25	581.63	581.63
A	1470+08.02	-9.25	581.71	581.70
B	1470+18.02	-9.25	581.77	581.76
CL Pier 1	1470+28.58	-9.25	581.83	581.83
C	1470+38.58	9.25	581.87	581.90
D	1470+48.58	-9.25	581.90	581.96
E	1470+58.58	-9.25	581.93	582.00
F	1470+68.58	-9.25	581.94	582.01
G	1470+78.58	-9.25	581.94	581.98
CL Pier 2	1470+92.41	-9.25	581.93	581.93
H	1471+02.41	-9.25	581.91	581.90
I	1471+12.41	-9.25	581.87	581.87
CL N. Abut.	1471+22.97	-9.25	581.83	581.83
Bk. N. Abut.	1471+24.33	-9.25	581.82	581.82

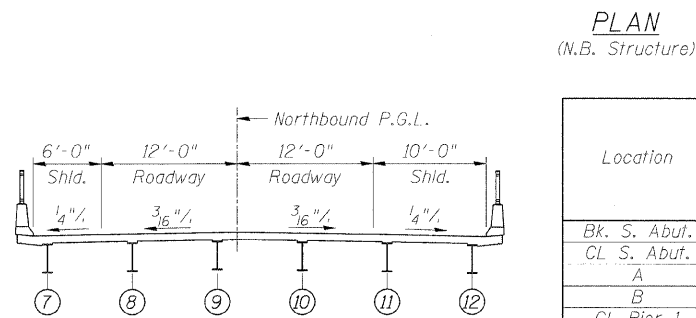

BEAM 9

Location	Station	Offset*	Theoretical Grade Elevations	Theoretical Grade Elevations Adjusted For Dead Load Deflection
Bk. S. Abut.	1469+93.43	-1.75	581.71	581.71
CL S. Abut.	1469+94.79	-1.75	581.72	581.72
A	1470+04.79	-1.75	581.80	581.80
B	1470+14.79	-1.75	581.87	581.86
CL Pier 1	1470+25.35	-1.75	581.93	581.93
C	1470+35.35	-1.75	581.98	582.00
D	1470+45.35	-1.75	582.01	582.07
E	1470+55.35	-1.75	582.04	582.11
F	1470+65.35	-1.75	582.05	582.12
G	1470+75.35	-1.75	582.06	582.10
CL Pier 2	1470+89.18	-1.75	582.05	582.05
H	1470+99.18	-1.75	582.03	582.02
I	1471+09.18	-1.75	582.00	582.00
CL N. Abut.	1471+19.73	-1.75	581.96	581.96
Bk. N. Abut.	1471+21.10	-1.75	581.95	581.95

NORTHBOUND P.G.L.

Location	Station	Offset*	Theoretical Grade Elevations	Theoretical Grade Elevations Adjusted For Dead Load Deflection
Bk. S. Abut.	1469+92.67	0.00	581.73	581.73
CL S. Abut.	1469+94.03	0.00	581.74	581.74
A	1470+04.03	0.00	581.82	581.82
B	1470+14.03	0.00	581.89	581.88
CL Pier 1	1470+24.59	0.00	581.95	581.95
C	1470+34.59	0.00	582.00	582.03
D	1470+44.59	0.00	582.04	582.10
E	1470+54.59	0.00	582.06	582.14
F	1470+64.59	0.00	582.08	582.15
G	1470+74.59	0.00	582.09	582.13
CL Pier 2	1470+88.42	0.00	582.08	582.08
H	1470+98.42	0.00	582.06	582.05
I	1471+08.42	0.00	582.03	582.03
CL N. Abut.	1471+18.98	0.00	581.99	581.99
Bk. N. Abut.	1471+20.34	0.00	581.99	581.99

BEAM 10

Location	Station	Offset*	Theoretical Grade Elevations	Theoretical Grade Elevations Adjusted For Dead Load Deflection
Bk. S. Abut.	1469+90.19	5.75	581.62	581.62
CL S. Abut.	1469+91.55	5.75	581.63	581.63
A	1470+01.55	5.75	581.71	581.71
B	1470+11.55	5.75	581.78	581.78
CL Pier 1	1470+22.11	5.75	581.85	581.85
C	1470+32.11	5.75	581.90	581.93
D	1470+42.11	5.75	581.94	582.00
E	1470+52.11	5.75	581.97	582.04
F	1470+62.11	5.75	581.99	582.06
G	1470+72.11	5.75	582.00	582.04
CL Pier 2	1470+85.94	5.75	581.99	581.99
H	1470+95.94	5.75	581.98	581.97
I	1471+05.94	5.75	581.95	581.95
CL N. Abut.	1471+16.50	5.75	581.91	581.91
Bk. N. Abut.	1471+17.86	5.75	581.91	581.91

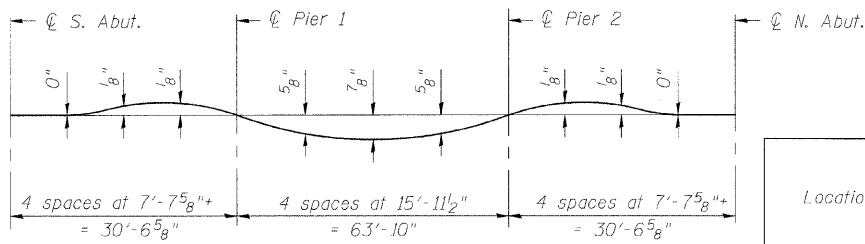

DEAD LOAD DEFLECTION DIAGRAM
(Includes weight of concrete only.)

Note:
The above deflections are not to be used in the field if the engineer is working from the grade elevations adjusted for dead load deflections as shown herein.

DESIGNED	CMM
CHECKED	AMK
DRAWN	EF
CHECKED	RWC

LOCHNER
H.W. LOCHNER, INC., CHICAGO, ILLINOIS

BEAM 11

Location	Station	Offset*	Theoretical Grade Elevations	Theoretical Grade Elevations Adjusted For Dead Load Deflection
Bk. S. Abut.	1469+86.95	13.25	581.47	581.47
CL S. Abut.	1469+88.31	13.25	581.48	581.48
A	1469+98.31	13.25	581.56	581.56
B	1470+08.31	13.25	581.64	581.63
CL Pier 1	1470+18.87	13.25	581.71	581.71
C	1470+28.87	13.25	581.76	581.79
D	1470+38.87	13.25	581.80	581.86
E	1470+48.87	13.25	581.84	581.91
F	1470+58.87	13.25	581.86	581.93
G	1470+68.87	13.25	581.87	581.91
CL Pier 2	1470+82.70	13.25	581.87	581.87
H	1470+92.70	13.25	581.86	581.85
I	1471+02.70	13.25	581.84	581.83
CL N. Abut.	1471+13.26	13.25	581.80	581.80
Bk. N. Abut.	1471+14.62	13.25	581.80	581.80

BEAM 12

Location	Station	Offset*	Theoretical Grade Elevations	Theoretical Grade Elevations Adjusted For Dead Load Deflection
Bk. S. Abut.	1469+83.72	20.75	581.28	581.28
CL S. Abut.	1469+85.08	20.75	581.29	581.29
A	1469+95.08	20.75	581.38	581.38
B	1470+05.08	20.75	581.46	581.45
CL Pier 1	1470+15.64	20.75	581.53	581.53
C	1470+25.64	20.75	581.59	581.62
D	1470+35.64	20.75	581.63	581.69
E	1470+45.64	20.75	581.67	581.75
F	1470+55.64	20.75	581.70	581.77
G	1470+65.64	20.75	581.71	581.75
CL Pier 2	1470+79.47	20.75	581.72	581.72
H	1470+89.47	20.75	581.71	581.70
I	1470+99.47	20.75	581.69	581.69
CL N. Abut.	1471+10.02	20.75	581.66	581.66
Bk. N. Abut.	1471+11.39	20.75	581.65	581.65

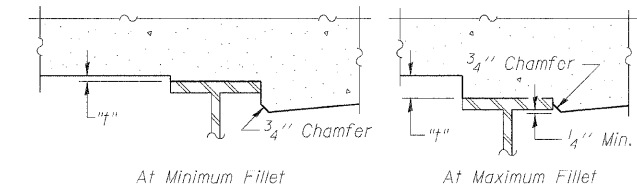

To determine "f": After all structural steel has been erected, elevations of the top flanges of the beams shall be taken at intervals shown herein. These elevations subtracted from the "Theoretical Grade Elevations Adjusted for Dead Load Deflection" shown herein, minus slab thickness, equals the fillet heights "f" above top flange of beams.

FILLET HEIGHTS

TOP OF SLAB ELEVATIONS (NB)
IL ROUTE 92 (CENTENNIAL EXPRESSWAY)
OVER 31st AVENUE
FAP ROUTE 308 SEC. 1(HB-2)R
ROCK ISLAND COUNTY
STATION 1470+70.31
STRUCTURE NO. 081-0172 (SB)
STRUCTURE NO. 081-0173 (NB)

STATE OF ILLINOIS
DEPARTMENT OF TRANSPORTATION

ROUTE NO.	SECTION	COUNTY	TOTAL SHEETS	SHEET NO.
F.A.P. 308	#	ROCK ISLAND	210	91
SHEET NO. 7 31 SHEETS				
FED. ROAD DIST. NO. 7	ILLINOIS	FED. AID PROJECT		
Contract #64814 * (IHB,HB-1,VB,HB-2)R				

WEST CURB LINE

Location	Station	Offset*	Theoretical Grade Elevations
End S. Appr. Pavement	1469+99.96	-22.42	581.55
A	1470+09.96	-22.42	581.61
B	1470+19.96	-22.42	581.66
Bk. S. Abut.	1470+29.96	-22.42	581.70
Bk. N. Abut.	1471+57.62	-22.42	581.37
C	1471+67.62	-22.42	581.28
D	1471+77.52	-22.42	581.17
End N. Appr. Pavement	1471+87.52	-22.42	581.06

WEST EDGE OF PAVEMENT

Location	Station	Offset*	Theoretical Grade Elevations
End S. Appr. Pavement	1469+95.47	-12.00	581.73
A	1470+05.47	-12.00	581.80
B	1470+15.47	-12.00	581.86
Bk. S. Abut.	1470+25.47	-12.00	581.90
Bk. N. Abut.	1471+53.13	-12.00	581.63
C	1471+63.13	-12.00	581.54
D	1471+73.13	-12.00	581.44
End N. Appr. Pavement	1471+83.13	-12.00	581.33

SOUTHBOUND P.G.L.

Location	Station	Offset*	Theoretical Grade Elevations
End S. Appr. Pavement	1469+90.29	0.00	581.88
A	1470+00.29	0.00	581.95
B	1470+10.29	0.00	582.01
Bk. S. Abut.	1470+20.29	0.00	582.07
Bk. N. Abut.	1471+47.95	0.00	581.86
C	1471+57.95	0.00	581.78
D	1471+67.95	0.00	581.68
End N. Appr. Pavement	1471+77.95	0.00	581.58

EAST EDGE OF PAVEMENT

Location	Station	Offset*	Theoretical Grade Elevations
End S. Appr. Pavement	1469+85.11	12.00	581.65
A	1469+95.11	12.00	581.73
B	1470+05.11	12.00	581.80
Bk. S. Abut.	1470+15.11	12.00	581.85
Bk. N. Abut.	1471+42.77	12.00	581.71
C	1471+52.77	12.00	581.63
D	1471+62.77	12.00	581.54
End N. Appr. Pavement	1471+72.77	12.00	581.44

EAST CURB LINE

Location	Station	Offset*	Theoretical Grade Elevations
End S. Appr. Pavement	1469+82.34	18.42	581.49
A	1469+92.34	18.42	581.57
B	1470+02.34	18.42	581.64
Bk. S. Abut.	1470+12.34	18.42	581.71
Bk. N. Abut.	1471+40.00	18.42	581.60
C	1471+50.00	18.42	581.52
D	1471+60.00	18.42	581.44
End N. Appr. Pavement	1471+70.00	18.42	581.34

* Offsets are taken from Southbound P.G.L.

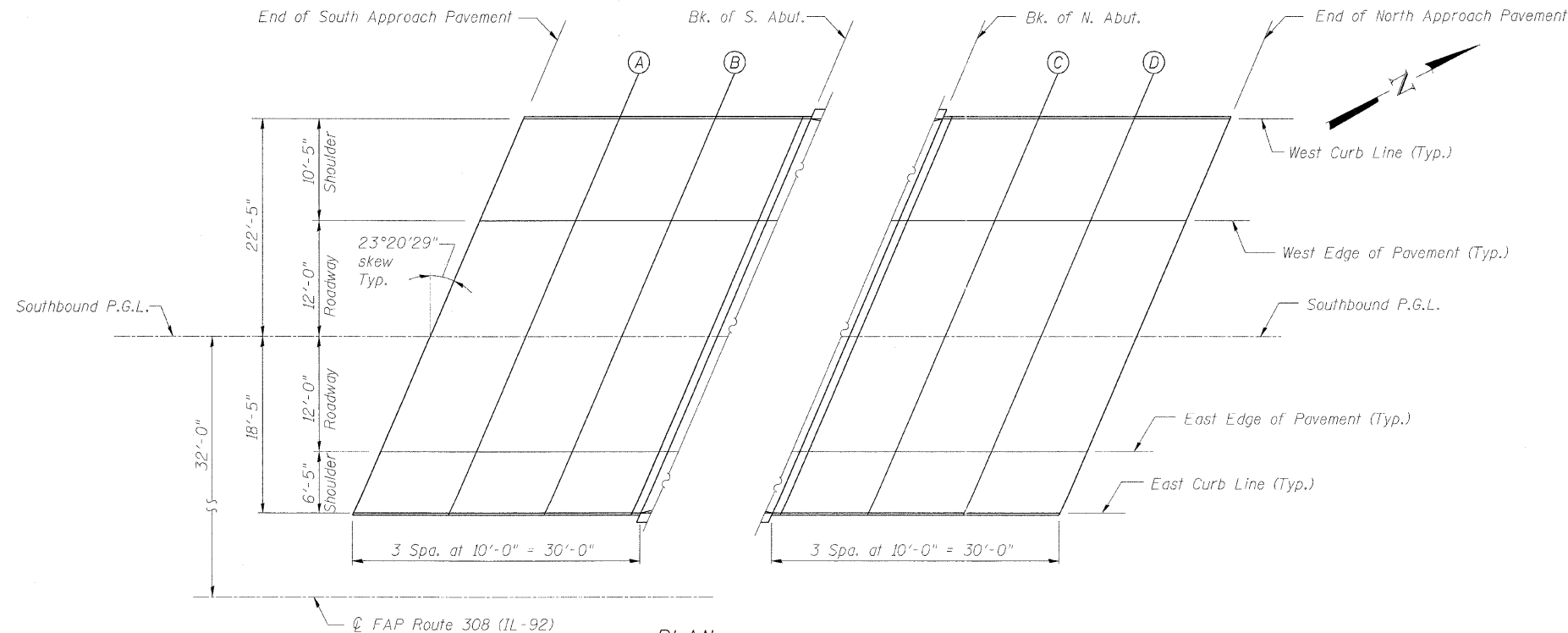

PLAN

TOP OF NORTH AND SOUTH APPROACH
SLAB ELEVATIONS (SB)
IL ROUTE 92 (CENTENNIAL EXPRESSWAY)
OVER 31st AVENUE
FAP ROUTE 308 SEC. 1(HB-2)R
ROCK ISLAND COUNTY
STATION 1470+70.31
STR. 081-0172 (SB) STR. NO. 081-0173 (NB)

DESIGNED	CMM
CHECKED	JSD
DRAWN	EF
CHECKED	RWC

LOCHNER
H.W. LOCHNER, INC., CHICAGO, ILLINOIS

t:\2082\struc\gnt\2044023EL3.dgn

STATE OF ILLINOIS
DEPARTMENT OF TRANSPORTATION

ROUTE NO.	SECTION	COUNTY	100% EST.	SHEET NO.	SHEET NO. 8
F.A.P. 308	*	ROCK ISLAND	210	92	31 SHEETS
FED. ROAD DIST. NO. 7	ILLINOIS	FED. AID PROJECT-			

Contract #64814 * (1HB,HB-1,VB,HB-2)R

WEST CURB LINE

Location	Station	Offset*	Theoretical Grade Elevations
End S. Appr. Pavement	1469+70.62	-18.42	581.20
A	1469+80.62	-18.42	581.30
B	1469+90.62	-18.42	581.39
Bk. S. Abut.	1470+00.62	-18.42	581.48
Bk. N. Abut.	1471+28.29	-18.42	581.62
C	1471+38.29	-18.42	581.57
D	1471+48.29	-18.42	581.50
End N. Appr. Pavement	1471+58.29	-18.42	581.42

WEST EDGE OF PAVEMENT

Location	Station	Offset*	Theoretical Grade Elevations
End S. Appr. Pavement	1469+67.85	-12.00	581.30
A	1469+77.85	-12.00	581.41
B	1469+87.85	-12.00	581.50
Bk. S. Abut.	1469+97.85	-12.00	581.59
Bk. N. Abut.	1471+25.52	-12.00	581.77
C	1471+35.52	-12.00	581.72
D	1471+45.52	-12.00	581.65
End N. Appr. Pavement	1471+55.52	-12.00	581.57

NORTHBOUND P.G.L.

Location	Station	Offset*	Theoretical Grade Elevations
End S. Appr. Pavement	1469+62.67	0.00	581.43
A	1469+72.67	0.00	581.54
B	1469+82.67	0.00	581.64
Bk. S. Abut.	1469+92.67	0.00	581.73
Bk. N. Abut.	1471+20.34	0.00	581.99
C	1471+30.34	0.00	581.93
D	1471+40.34	0.00	581.87
End N. Appr. Pavement	1471+50.34	0.00	581.80

EAST EDGE OF PAVEMENT

Location	Station	Offset*	Theoretical Grade Elevations
End S. Appr. Pavement	1469+57.49	12.00	581.18
A	1469+67.49	12.00	581.30
B	1469+77.49	12.00	581.40
Bk. S. Abut.	1469+87.49	12.00	581.50
Bk. N. Abut.	1471+15.16	12.00	581.82
C	1471+25.16	12.00	581.77
D	1471+35.16	12.00	581.72
End N. Appr. Pavement	1471+45.16	12.00	581.65

EAST CURB LINE

Location	Station	Offset*	Theoretical Grade Elevations
End S. Appr. Pavement	1469+53.00	22.42	580.91
A	1469+63.00	22.42	581.03
B	1469+73.00	22.42	581.14
Bk. S. Abut.	1469+83.00	22.42	581.24
Bk. N. Abut.	1471+10.67	22.42	581.62
C	1471+20.67	22.42	581.58
D	1471+30.67	22.42	581.53
End N. Appr. Pavement	1471+40.67	22.42	581.47

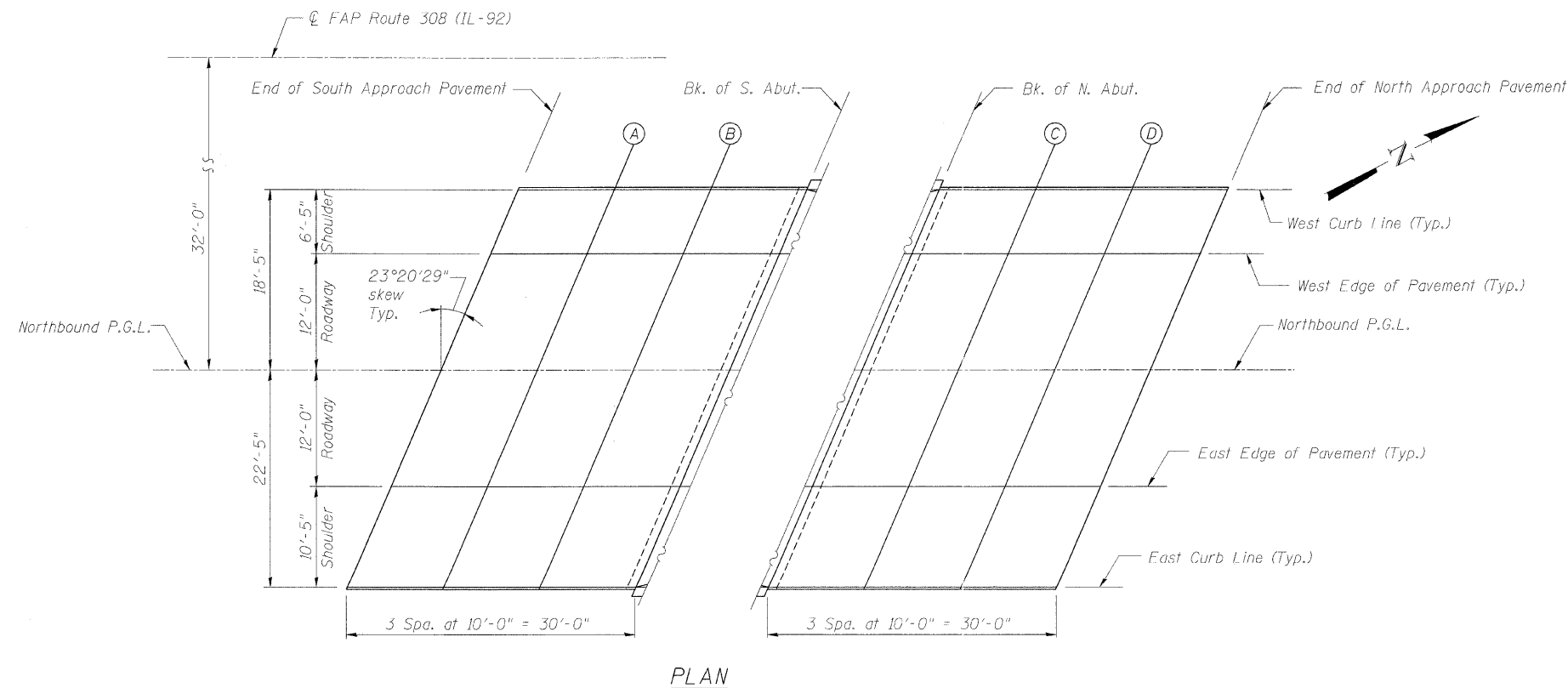

* Offsets are taken from Northbound P.G.L.

TOP OF NORTH AND SOUTH APPROACH
SLAB ELEVATIONS (NB)
IL ROUTE 92 (CENTENNIAL EXPRESSWAY)
OVER 31st AVENUE
FAP ROUTE 308 SEC. 1(HB-2)R
ROCK ISLAND COUNTY
STATION 1470+70.31
STR. 081-0172 (SB) STR. NO. 081-0173 (NB)

DESIGNED	CMM
CHECKED	JSD
DRAWN	EF
CHECKED	RWC

LOCHNER
H.W. LOCHNER, INC., CHICAGO, ILLINOIS

t:\2082\st-uct\dgn\2044023EL4.dgn

STATE OF ILLINOIS
DEPARTMENT OF TRANSPORTATION

ROUTE NO.	SECTION	COUNTY	TOTAL SHEETS	SHEET NO.	SHEET NO. 9
F.A.P. 308	*	ROCK ISLAND	210	93	31 SHEETS
FED. ROAD DIST. NO. 7	ILLINOIS	FED. AID PROJECT			

Contract #64814 * (1HB,HB-1,VB,HB-2)R

* Order a60(E) bars full length.
Cut to fit skew and use remainder
of bars in opposite end.

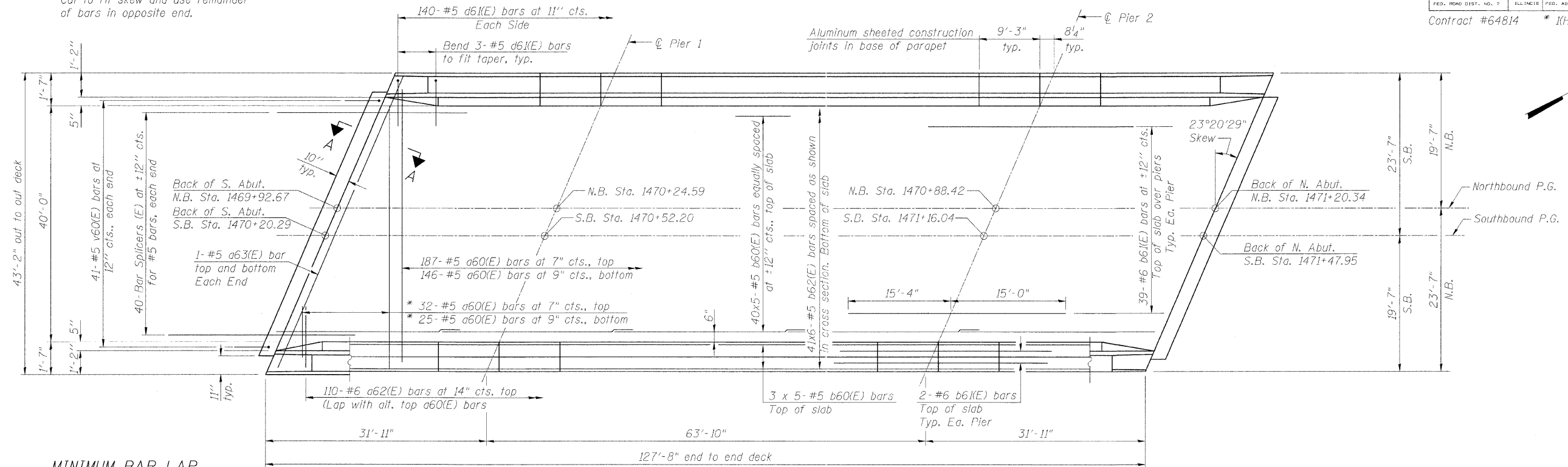

MINIMUM BAR LAP
(Deck)
#5 bar = 2'-2"

PLAN
(Southbound Plan Shown, Northbound Plan Similar Except as noted.)

NOTES

1. Bars indicated thus 20x3-#5 etc. indicates 20 lines of bars with 3 lengths per line.
2. For parapet reinforcement see Sheet No. 11
3. For Bar List and Bill of Material see Sheet No. 11
4. All edges shall have a 3/4" chamfer except as noted.
5. For Section A-A see Sheet No. 10
6. Protective coat shall be applied to the deck and top and inside faces of parapet.
7. For spacing of partial depth parapet joints see Sheet No. 11

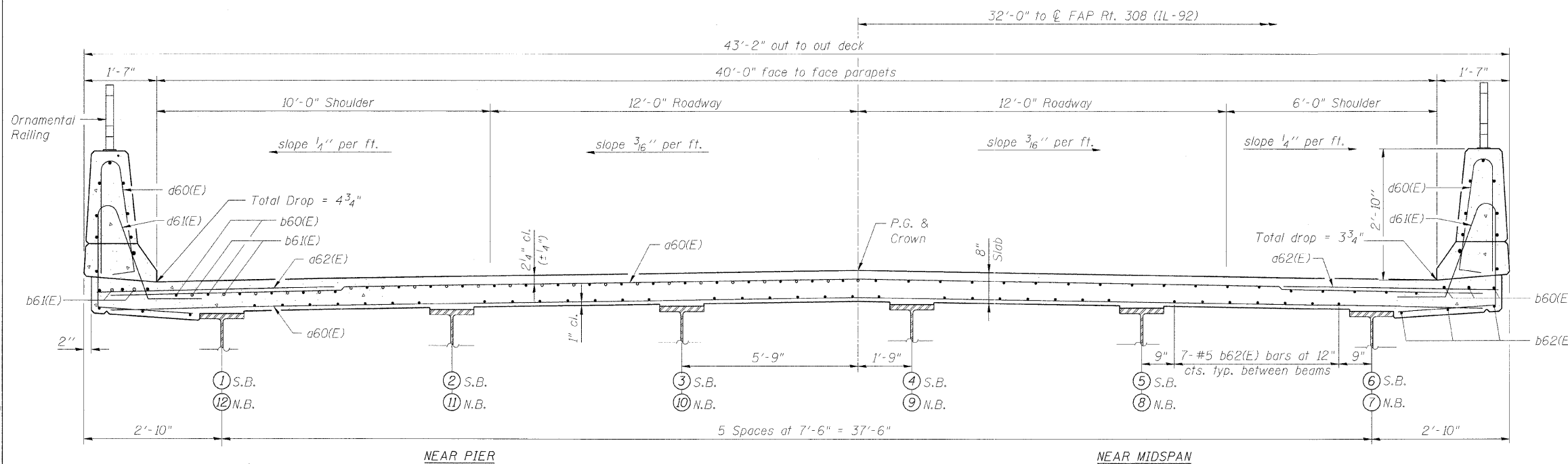

CROSS SECTION

(Looking North)
(Southbound Section Shown, Northbound Section Similar, Opposite Hand)

DECK PLAN
IL ROUTE 92 (CENTENNIAL EXPRESSWAY)
OVER 31st AVENUE
FAP ROUTE 308 SEC. 1(HB-2)R
ROCK ISLAND COUNTY
STATION 1470+70.31
STRUCTURE NO. 081-0172 (SB)
STRUCTURE NO. 081-0173 (NB)

DESIGNED	CMM
CHECKED	JSD
DRAWN	EF
CHECKED	RWC

LOCHNER
H.W. LOCHNER, INC., CHICAGO, ILLINOIS

t: 2082628 v: 1.0 d: 2011/04/20 11:49

STATE OF ILLINOIS
DEPARTMENT OF TRANSPORTATION

ROUTE NO.	SECTION	COUNTY	TOTAL SHEETS	SHEET NO.	SHEET NO. 10 31 SHEETS
F.A.P. 308	*	ROCK ISLAND	210	94	
FED. ROAD DIST. NO. 7		ILLINOIS	FED. AID PROJECT		

Contract #64814 * (HB,HB-1,VB,HB-2)R

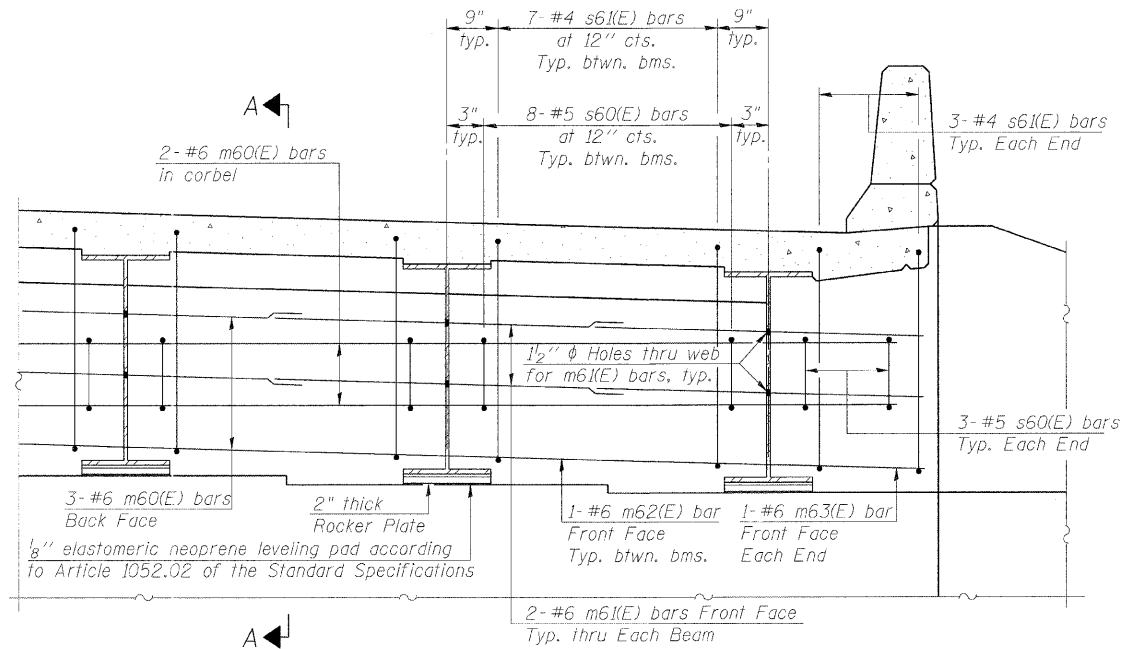

DIAPHRAGM ELEVATION AT ABUTMENT

MIN. BAR LAP
#6 bar = 2'-9"

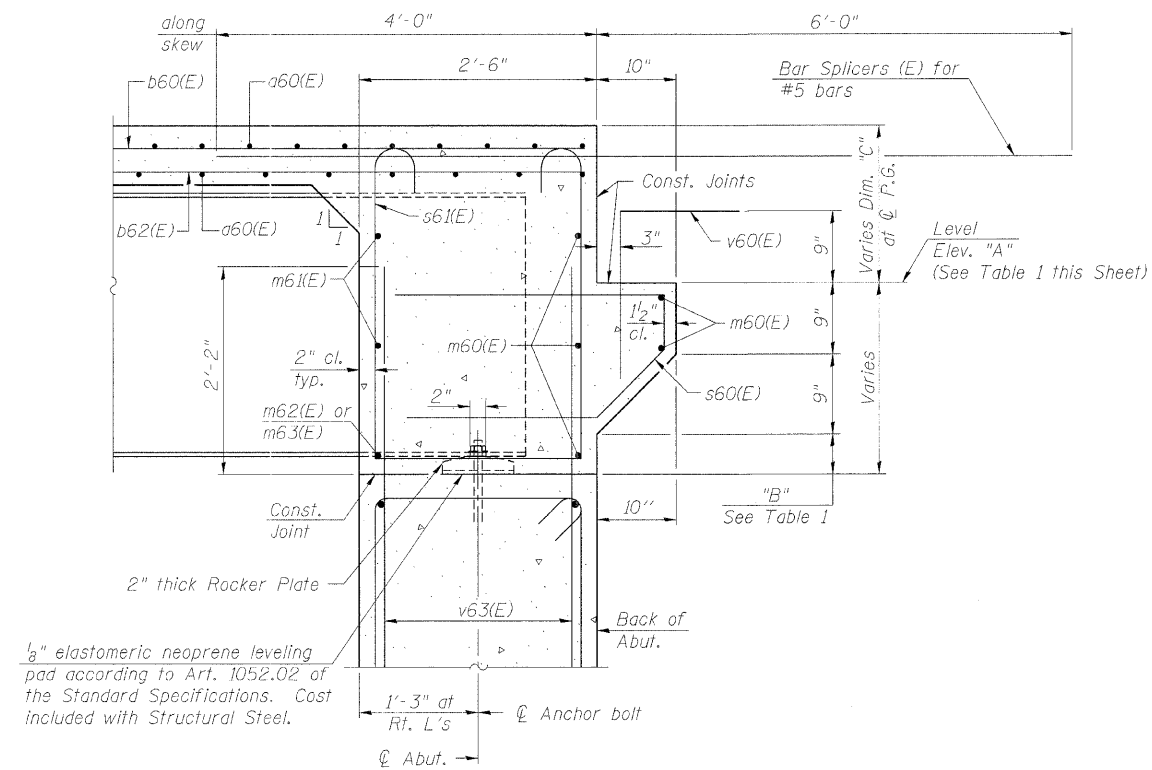

SECTION A-A

Dimensions at right angles to abutment, except as shown.

TABLE 1

Location	Elev. "A"	Dim. "B"	Dim. "C"
SB South Abutment	580.36	Varies 2 ³ / ₄ " to 5 ³ / ₄ "	1'-8 ¹ / ₂ "
SB North Abutment	580.03	Varies 2 ³ / ₈ " to 5 ³ / ₈ "	1'-10"
NB South Abutment	579.90	Varies 2 ⁵ / ₈ " to 5 ³ / ₄ "	1'-10"
NB North Abutment	580.28	Varies 2 ⁵ / ₈ " to 5 ⁵ / ₈ "	1'-8 ¹ / ₂ "

NOTES

1. Reinforcement bars in diaphragm are billed with superstructure on Sheet No. 11
2. Concrete in diaphragm is included with Concrete Superstructure on Sheet No. 11
3. For details of bars s60(E) and s61(E) see Sheet No. 11
4. The s60(E) and s61(E) bars shall be placed parallel to the beams. Spacing for these bars shall be at right angles to the beams.
5. For rocker plate detail see Sheet No. 15

INTEGRAL ABUTMENT DIAPHRAGM DETAILS
IL ROUTE 92 (CENTENNIAL EXPRESSWAY)
OVER 31st AVENUE
FAP ROUTE 308 SEC. 1(HB-2)R
ROCK ISLAND COUNTY
STATION 1470+70.31
STRUCTURE NO. 081-0172 (SB)
STRUCTURE NO. 081-0173 (NB)

DESIGNED	CMM
CHECKED	JSD
DRAWN	EF
CHECKED	RWC

LOCHNER
H.W. LOCHNER, INC., CHICAGO, ILLINOIS

t:\2082\est-uct\dgn\ZD44023SD1.dgn

STATE OF ILLINOIS
DEPARTMENT OF TRANSPORTATION

ROUTE NO.	SECTION	COUNTY	SHEET NO.	SHEET NO.
F.A.P. 308	*	ROCK ISLAND	210	95
FED. ROAD DIST. NO. 7 ILLINOIS FED. AID PROJECT-				

Contract #64814 * (IHB, HB-1, VB, HB-2)R

31 SHEETS

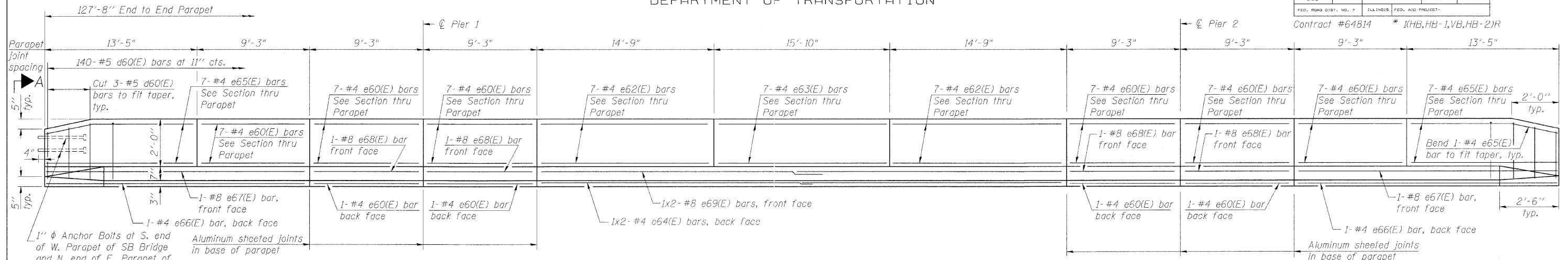

INSIDE ELEVATION OF PARAPET

MINIMUM BAR LAP
(Parapet)
#4 bar = 1'-4"
#8 bar = 3'-5"

SUPERSTRUCTURE BILL OF MATERIAL NB

Bar	No.	Size	Length	Shape
a60(E)	390	#5	42'-6"	—
a62(E)	220	#6	6'-0"	—
a63(E)	4	#5	46'-3"	—
b60(E)	230	#5	27'-3"	—
b61(E)	86	#6	30'-4"	—
b62(E)	246	#5	23'-1"	—
d60(E)	280	#5	5'-7"	⌒
d61(E)	280	#5	7'-7"	⌒
e60(E)	92	#4	8'-11"	—
e62(E)	28	#4	14'-5"	—
e63(E)	14	#4	15'-6"	—
e64(E)	4	#4	23'-4"	—
e65(E)	28	#4	13'-1"	—
e66(E)	4	#4	22'-4"	—
e67(E)	4	#8	22'-4"	—
e68(E)	8	#8	8'-11"	—
e69(E)	4	#8	24'-5"	—
m60(E)	10	#6	46'-3"	—
m61(E)	24	#6	11'-0"	—
m62(E)	10	#6	7'-9"	—
m63(E)	4	#6	2'-8"	—
s60(E)	92	#5	6'-3"	⌒
s61(E)	82	#4	9'-1"	⌒
v60(E)	82	#5	3'-4"	⌒
Reinforcement Bars, Epoxy Coated			Pound	44,310
Concrete Superstructure			Cu. Yds.	201.9

SUPERSTRUCTURE BILL OF MATERIAL SB

Bar	No.	Size	Length	Shape
a60(E)	390	#5	42'-6"	—
a62(E)	220	#6	6'-0"	—
a63(E)	4	#5	46'-3"	—
b60(E)	230	#5	27'-3"	—
b61(E)	86	#6	30'-4"	—
b62(E)	246	#5	23'-1"	—
d60(E)	280	#5	5'-7"	⌒
d61(E)	280	#5	7'-7"	⌒
e60(E)	92	#4	8'-11"	—
e62(E)	28	#4	14'-5"	—
e63(E)	14	#4	15'-6"	—
e64(E)	4	#4	23'-4"	—
e65(E)	28	#4	13'-1"	—
e66(E)	4	#4	22'-4"	—
e67(E)	4	#8	22'-4"	—
e68(E)	8	#8	8'-11"	—
e69(E)	4	#8	24'-5"	—
m60(E)	10	#6	46'-3"	—
m61(E)	24	#6	11'-0"	—
m62(E)	10	#6	7'-9"	—
m63(E)	4	#6	2'-8"	—
s60(E)	92	#5	6'-3"	⌒
s61(E)	82	#4	9'-1"	⌒
v60(E)	82	#5	3'-4"	⌒
Reinforcement Bars, Epoxy Coated			Pound	44,310
Concrete Superstructure			Cu. Yds.	201.9

Non-staining gray one component non-sag elastomeric gun grade polyurethane sealant meeting the requirements of ASTM C-920, Type S, Grade NS, Class 25. Use T with a 5/8" backer rod.

1/2" Preformed Self-Expanding Cork Joint Filler according to Article 1051.07 of the Std. Spec. Cost included with Concrete Superstructure.

Const. Jts. at Piers 1/8" Aluminum sheet ASTM B 209 alloy 3003-H14. Cost included with Concrete Superstructure

Const. Jt. (Optional)
Const. Jt. (Mandatory)

PARAPET JOINT DETAILS

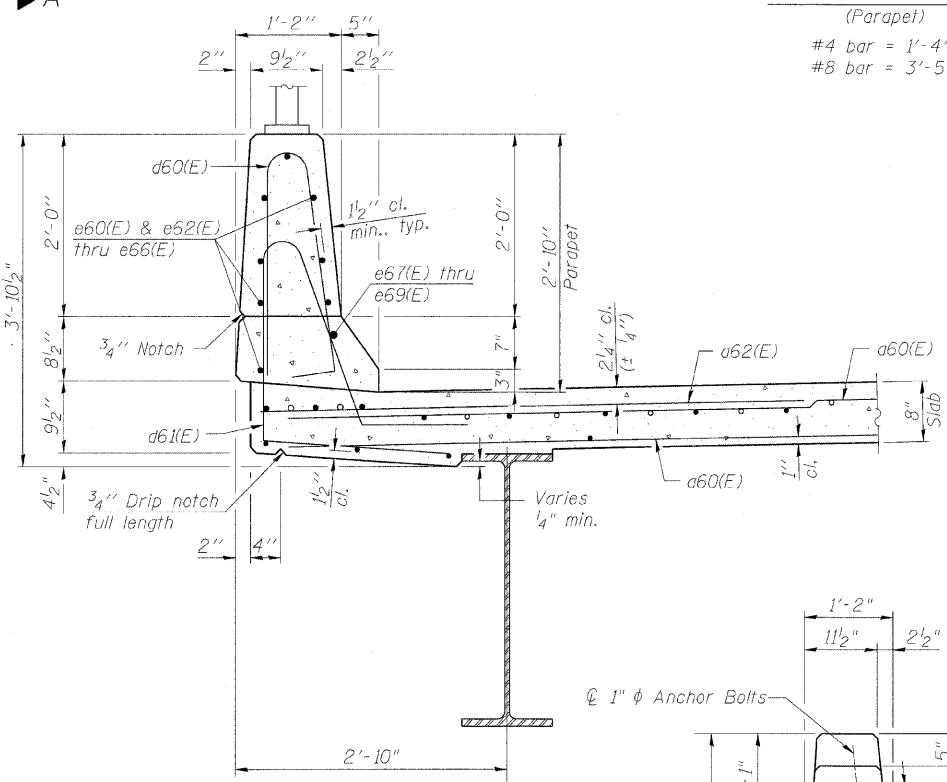

SECTION THRU PARAPET

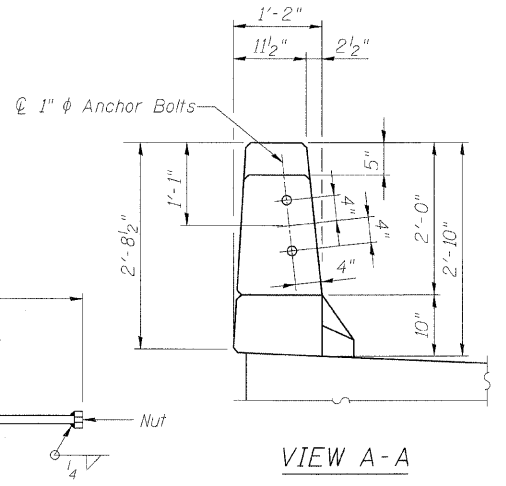

VIEW A-A

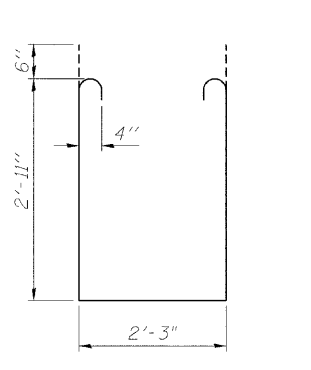

BAR s61(E)

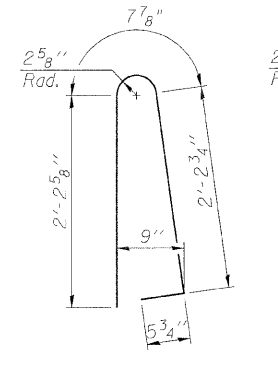

BAR d60(E)

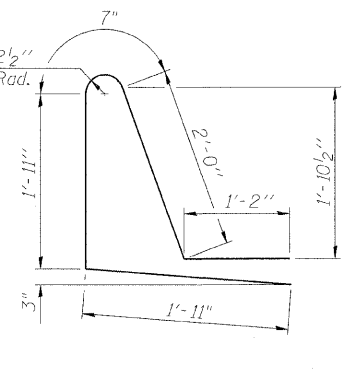

BAR d61(E)

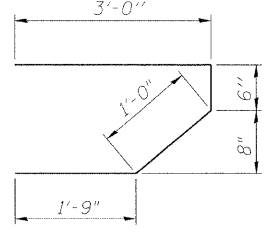

BAR s60(E)

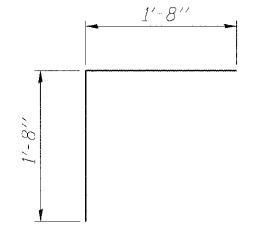

BAR v60(E)

NOTES

1. Bars indicated thus 1x2-#5 etc. indicates 1 line of bars with 2 lengths per line.
2. All edges shall have a 3/4" chamfer except as noted.

PARAPET DETAILS
IL ROUTE 92 (CENTENNIAL EXPRESSWAY)
OVER 31st AVENUE
FAP ROUTE 308 SEC. 1(IHB-2)R
ROCK ISLAND COUNTY
STATION 1470+70.31
STRUCTURE NO. 081-0172 (SB)
STRUCTURE NO. 081-0173 (NB)

DESIGNED	CMM
CHECKED	JSD
DRAWN	EF
CHECKED	RWC

LOCHNER
H.W. LOCHNER, INC., CHICAGO, ILLINOIS

1" Ø ANCHOR BOLT

t:\2082\struc\cogn\2044023P01.dgn

STATE OF ILLINOIS
DEPARTMENT OF TRANSPORTATION

ROUTE NO.	SECTION	COUNTY	TOTAL SHEETS	SHEET NO.	SHEET NO. 12 31 SHEETS
F.A.P. 308	*	ROCK ISLAND	210	96	
FED. ROAD DIST. NO. 7	ILLINOIS	FED. AID PROJECT-	Contract #64814 * 1(HB,HB-1,VB,HB-2)R		

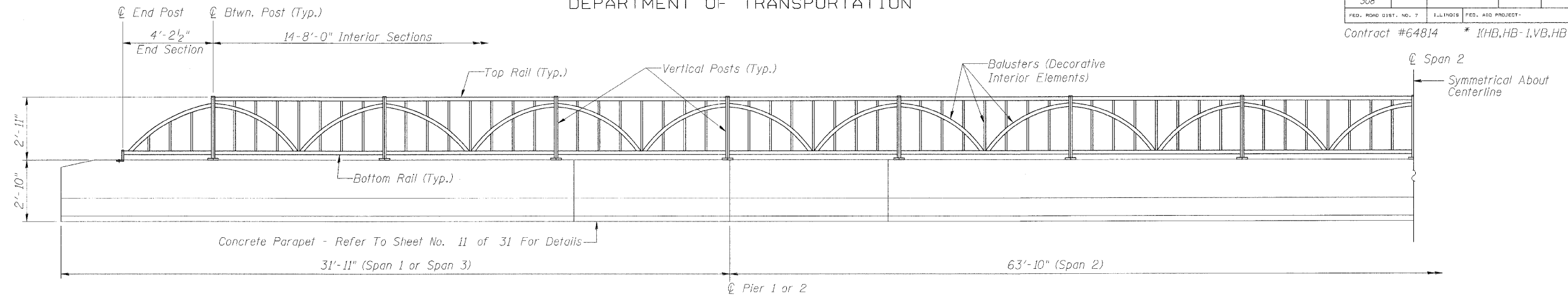

AESTHETIC BRIDGE RAIL ELEVATION
(Exterior Elevation)

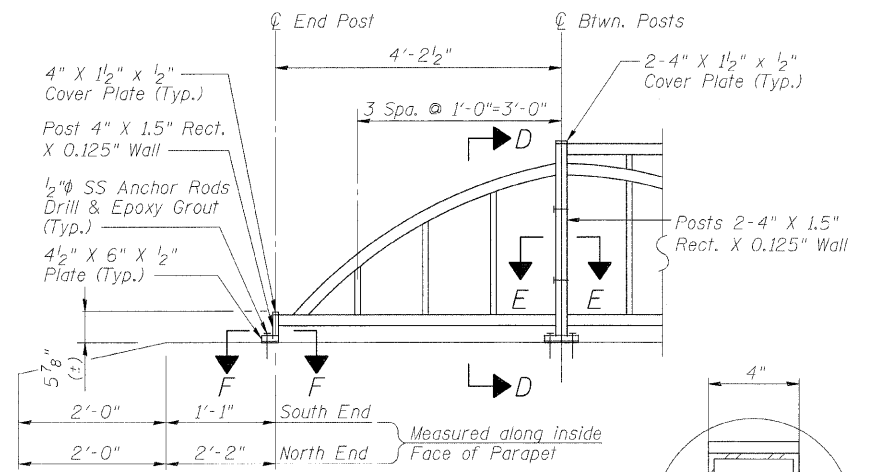

TYPICAL END SECTION

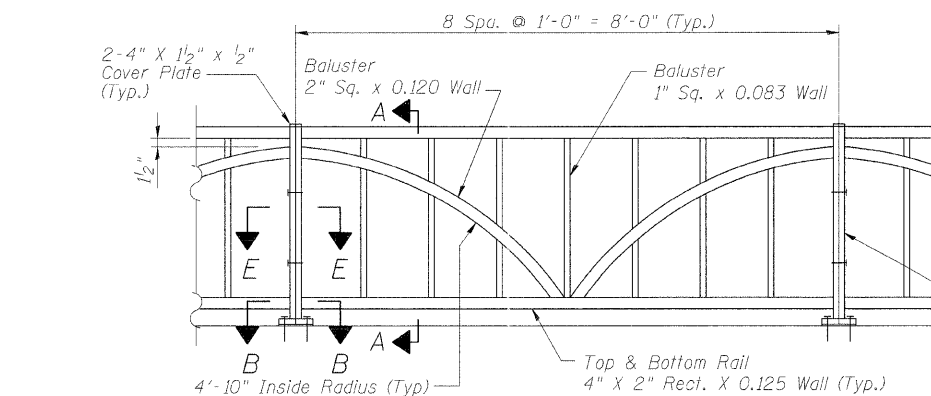

TYPICAL INTERIOR SECTION

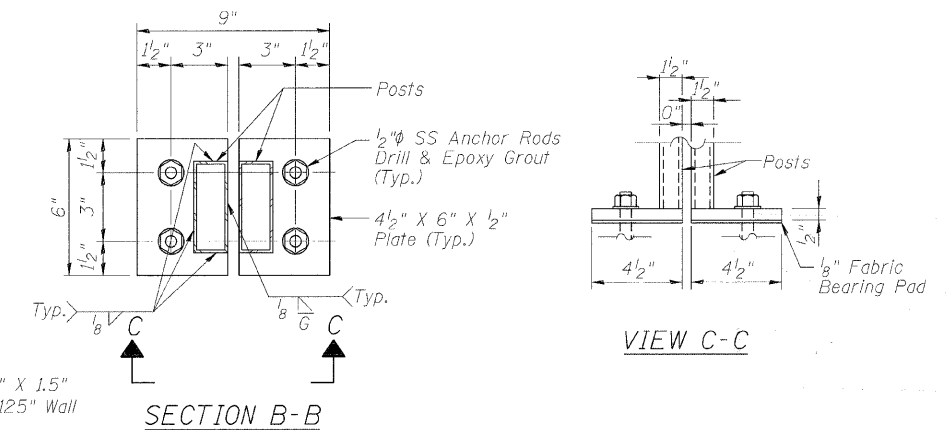

SECTION B-B

VIEW C-C

BILL OF MATERIAL

Item	Unit	Quantity
Ornamental Railing	Foot	482

NOTES:

- Ornamental Rail. Ornamental-Aluminum alloy rail shall conform to the requirements of Alloy 6061-T6 with a minimum yield of 35,000 psi, a minimum tensile strength of 38,000 psi, and an elongation of 10 percent in 2 in.
- Stainless Steel Carriage Bolts. Stainless steel nuts, washers, lock washers, carriage bolts shall conform to the requirements of Article 1006.29(d) of the Standard Specifications.
- Stainless Steel Bars. Stainless steel bars shall conform to the requirements of ASTM A 276, Type No. 302 or 304, Condition B. Threads, when required, shall be Class 2B.
- Three stainless steel shims per post (1 at 1/8 in. and 2 at 1/16 in.) shall be provided for 25 percent of the posts. Shims shall be similar to base plate in size and holes. Shims shall be installed as req'd. between base plate and fabric bearing pad.
- The pay item Ornamental Railing shall include all costs associated with the fabrication and erection of aluminum rail shown. The cost of anchor rods, plates, bolts, epoxy grouting, and fabric bearing pads shall be included with Ornamental Railing.

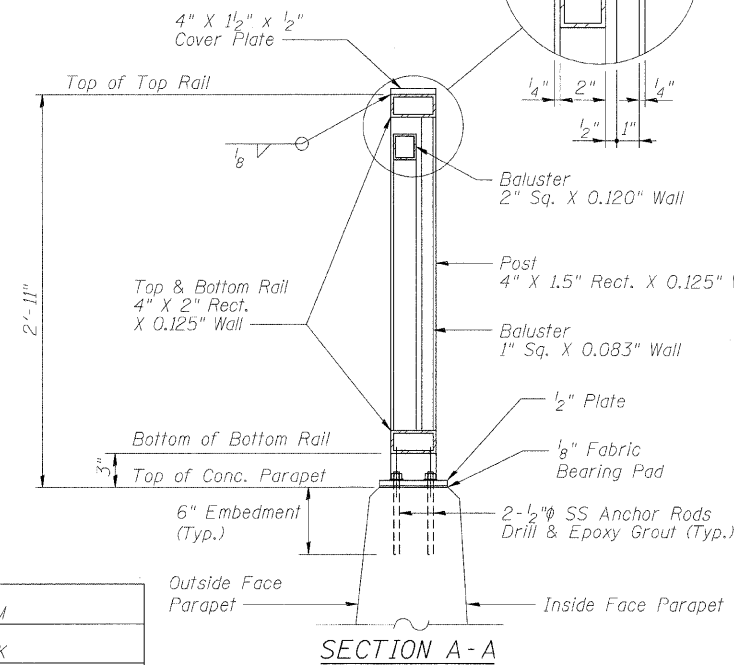

SECTION A-A

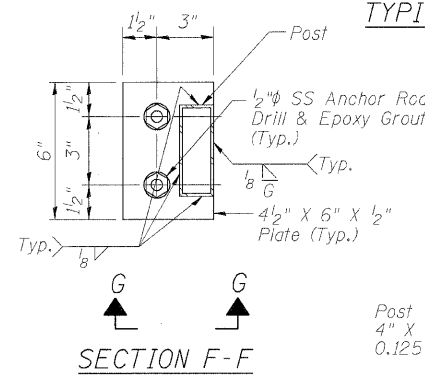

SECTION F-F

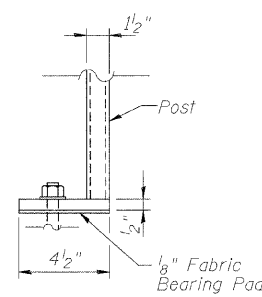

VIEW G-G

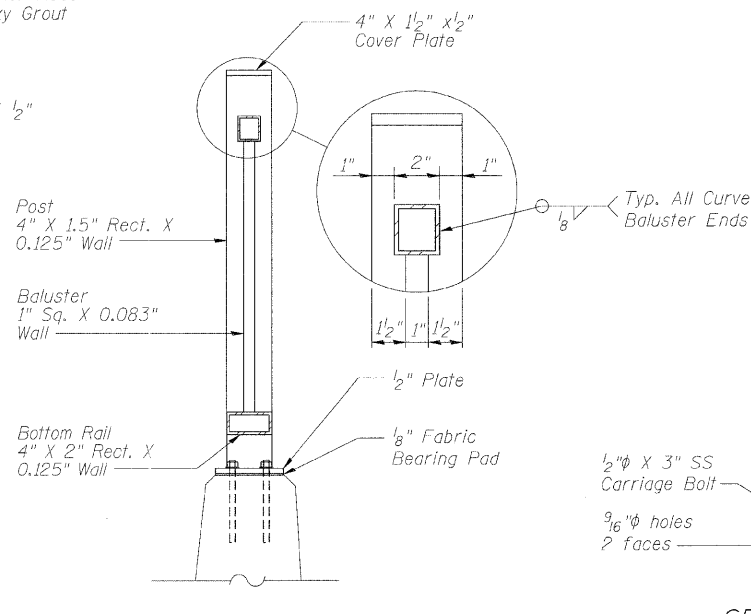

SECTION D-D

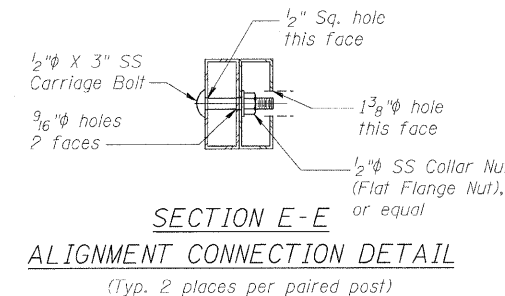

SECTION E-E
ALIGNMENT CONNECTION DETAIL
(Typ. 2 places per paired post)

DESIGNED	CMM
CHECKED	AMK
DRAWN	
CHECKED	RWC

LOCHNER
H.W. LOCHNER, INC., CHICAGO, ILLINOIS

ORNAMENTAL RAILING DETAILS
IL ROUTE 92 (CENTENNIAL EXPRESSWAY)
OVER 31st AVENUE
FAP ROUTE 308 SEC. 1(HB-2)R
ROCK ISLAND COUNTY
STATION 1470+70.31
STRUCTURE NO. 081-0172 (SB)
STRUCTURE NO. 081-0173 (NB)

t:\2082\struc\cadd\gnk\2044023RD1.dgn

Contract #

STATE OF ILLINOIS
DEPARTMENT OF TRANSPORTATION

ROUTE NO. F.A.P. 308	SECTION #	COUNTY ROCK ISLAND	STATE 210	SHEET 97	SHEET NO. 13 31 SHEETS
FED. ROAD DIST. NO. 7		ILLINOIS		FED. AID PROJECT	

Contract #64814 * (HB,HB-1,VB,HB-2)R

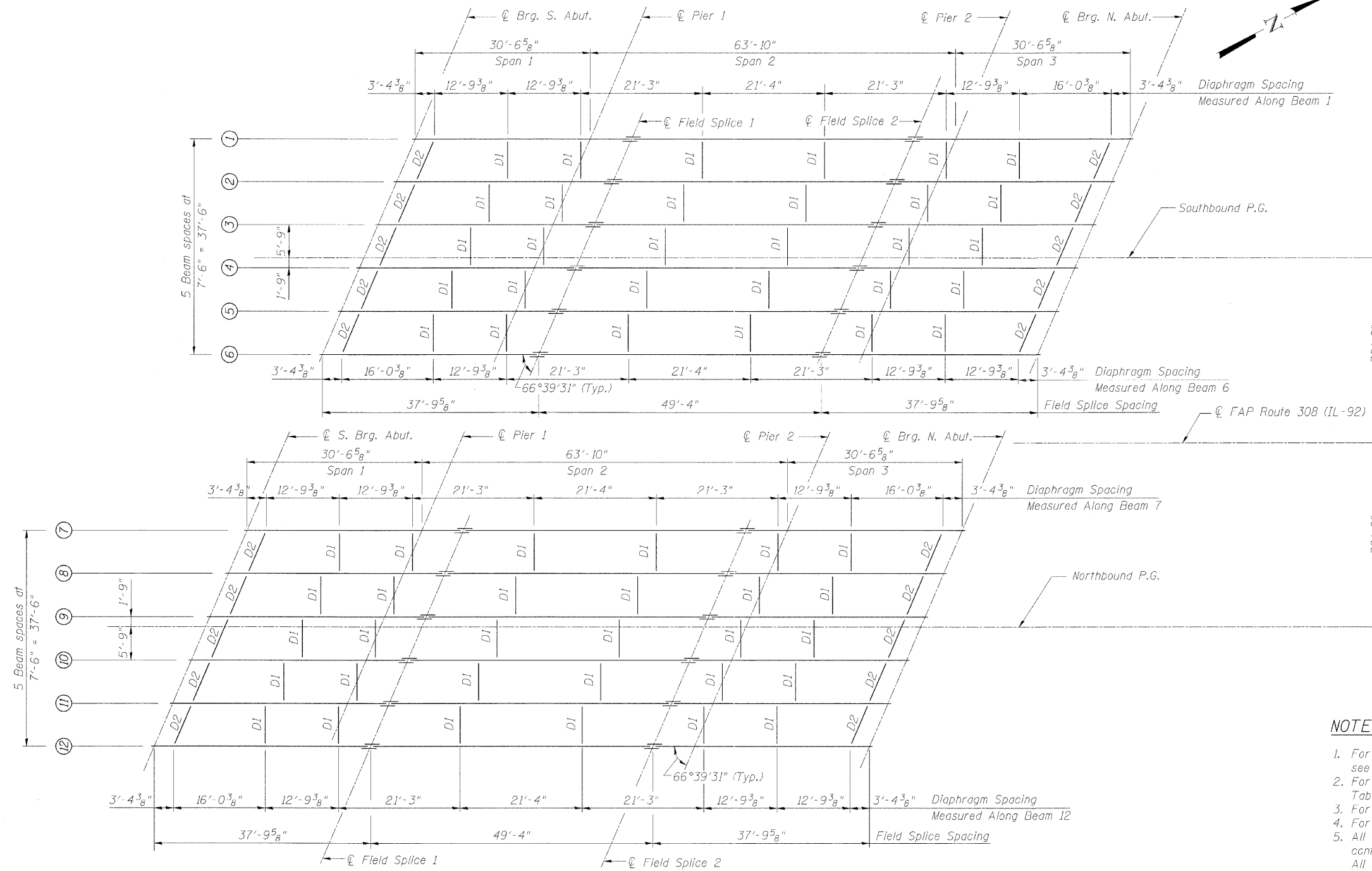

FRAMING PLAN

NOTES

1. For beam elevation and shear stud spacing see Sheet No. 14
2. For Top of Beam Elevations and Moment and Reaction Table see Sheet No. 15
3. For splice and diaphragm details see Sheet No. 14
4. For bearing details, see Sheet No. 15
5. All steel for the steel beams, including splice plates, shall conform to the requirements of AASHTO M270 Grade 50. All diaphragms, including connection angles and plates, shall conform to the requirements of AASHTO M270, Grade 36.

FRAMING PLAN
IL ROUTE 92 (CENTENNIAL EXPRESSWAY)
OVER 31st AVENUE
FAP ROUTE 308 SEC. 1(HB-2)R
ROCK ISLAND COUNTY
STATION 1470+70.31
STRUCTURE NO. 081-0172 (SB)
STRUCTURE NO. 081-0173 (NB)

DESIGNED	JSD
CHECKED	RH
DRAWN	EF
CHECKED	RH

LOCHNER
H.W. LOCHNER, INC., CHICAGO, ILLINOIS

t:\2082\struet\dgn\c2044023FP1.dgn

STATE OF ILLINOIS
DEPARTMENT OF TRANSPORTATION

ROUTE NO.	SECTION	COUNTY	TOTAL SHEETS	SHEET NO.	SHEET NO. 14
F.A.P. 308	#	ROCK ISLAND	210	98	31 SHEETS
FED. ROAD DIST. NO. 7	ILLINOIS	FED. AID PROJECT-			

Contract #64814 * (1HB, HB-1, VB, HB-2)R

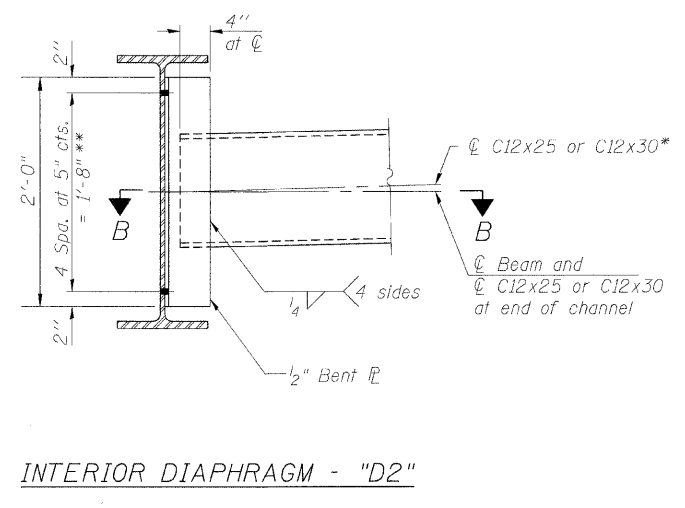
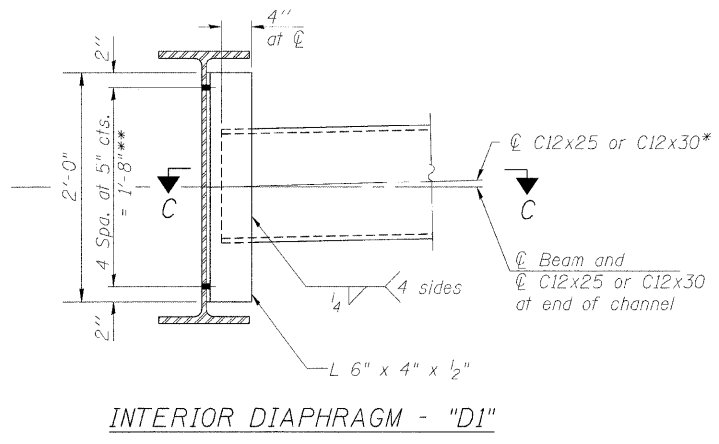
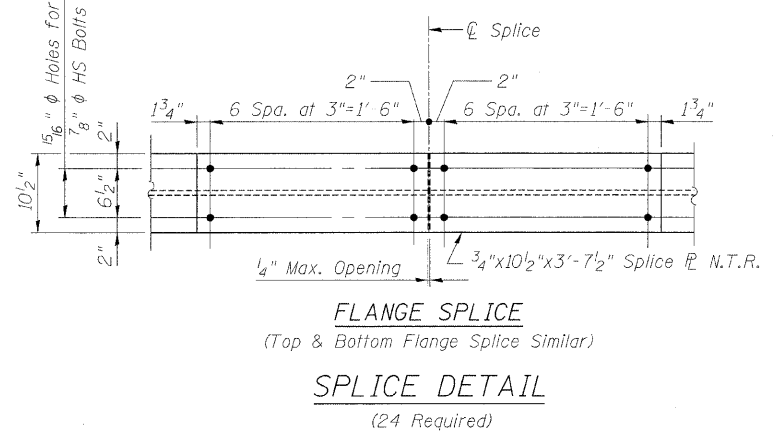
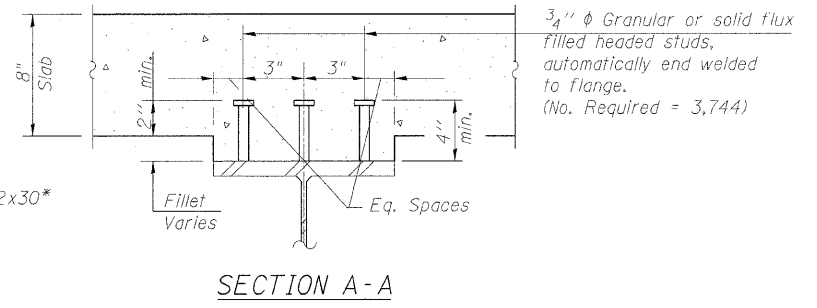
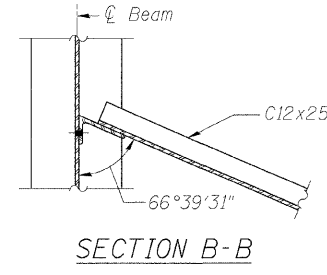
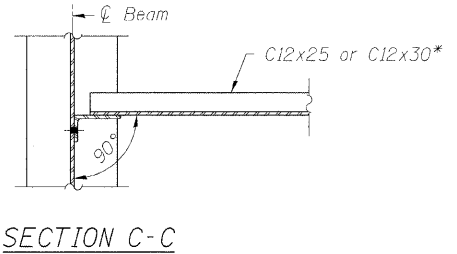
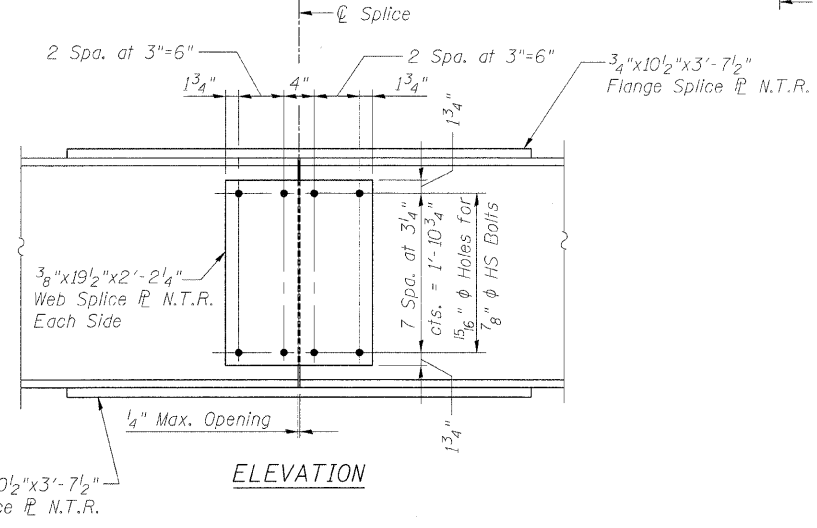
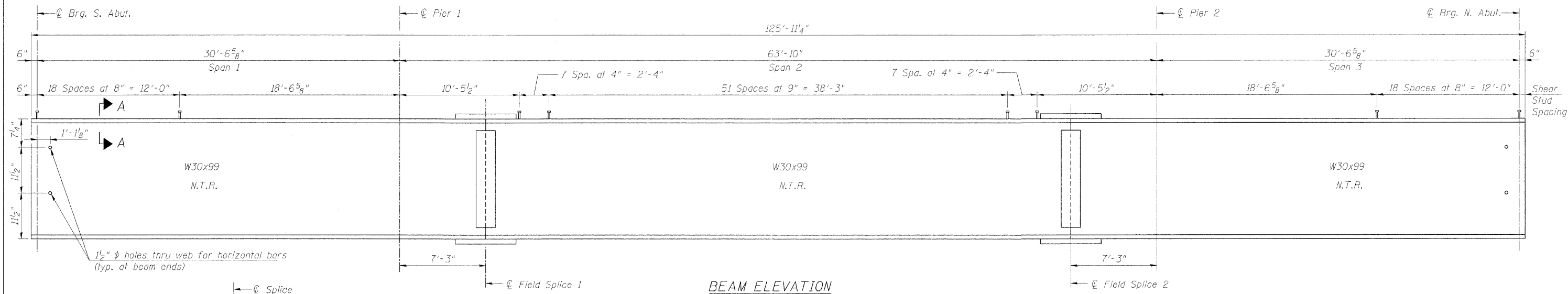

- NOTES**
1. Load carrying components designated "NTR" shall conform to the Supplemental Requirements for Notch Toughness, Zone 2.
 2. For bearing details see Sheet No. 15
 3. All steel for the steel beams, including splice plates, shall conform to the requirements of AASHTO M270 Grade 50. All diaphragms, including connection angles and plates, shall conform to the requirements of AASHTO M270 Grade 36.
 4. For framing plan see Sheet No. 13
 5. For Top of Beam Elevations and Moment and Reaction Table see Sheet No. 15
 6. All cross frames or diaphragms shall be installed as steel is erected and secured with erection pins and bolts except as otherwise noted. Individual cross frames or diaphragms at supports may be temporarily disconnected to install bearing anchor rods.

STEEL DETAILS 1
IL ROUTE 92 (CENTENNIAL EXPRESSWAY)
OVER 31st AVENUE
FAP ROUTE 308 SEC. 1(HB-2)R
ROCK ISLAND COUNTY
STATION 1470+70.31
STRUCTURE NO. 081-0172 (SB)
STRUCTURE NO. 081-0173 (NB)

DESIGNED	JSD
CHECKED	RH
DRAWN	EF
CHECKED	RH

LOCHNER
H.W. LOCHNER, INC., CHICAGO, ILLINOIS

Note:
Two hardened washers required for each set of oversized holes.

* Alternate channels are permitted to facilitate material acquisition. Calculated weight of structural steel is based on the lighter section.

*** 3/4" φ HS bolts, 1 5/16" φ holes

t:\2082\structure\20440230E1.dgn

STATE OF ILLINOIS
DEPARTMENT OF TRANSPORTATION

ROUTE NO.	SECTION	COUNTY	SHEETS	SHEET NO.
F.A.P. 308	*	ROCK ISLAND	210	99
31 SHEETS				
FED. ROAD DIST. NO. 7	ILLINOIS	FED. AID PROJECT-		

Contract #64814 * (1HB, HB-1, VB, HB-2)R

		0.3 Sp. 1 or 0.7 Sp. 3	Pier	0.5 Span 2
I_s	(in ⁴)	3990	3990	3990
$I_c(n)$	(in ⁴)	-	-	11469
$I_c(3n)$	(in ⁴)	-	-	8731
S_s	(in ³)	269	269	269
$S_c(n)$	(in ³)	-	-	407
$S_c(3n)$	(in ³)	-	-	371
Z	(in ³)	312	312	-
$\bar{\rho}$	(k'/')	1.39	1.39	0.89
$M\bar{\rho}$	(k)	26	367	203
$s\bar{\rho}$	(k'/')	-	-	0.50
$M_s\bar{\rho}$	(k)	-	-	140
M_L	(k)	162	184	425
M_{Imp}	(k)	48	53	113
$\bar{\rho}_s [M_L + M_{Imp}]$	(k)	350	395	897
M_a	(k)	489	991	1612
M_u	(k)	1121	1121	2085
$f_s \bar{\rho}$ (nc)	(ksi)	1.2	16.4	9.1
$f_s \bar{\rho}$ (c)	(ksi)	-	-	4.5
f_s (Overload)	(ksi)	16.8	34.0	40.0
f_s (Total)	(ksi)	-	-	-
VR	(k)	55.9	-	48.9

		S. Abut.	Pier 1	Pier 2	N. Abut.
$R\bar{\rho}$	(k)	10.1	77.8	77.8	10.1
$R\bar{\rho}$	(k)	37.0	51.0	51.0	37.0
Imp.	(k)	11.1	11.6	11.6	11.1
R_{Total}	(k)	58.3	140.4	140.4	58.3

* Compact section
** Braced non-compact and partially braced section

TOP OF BEAM ELEVATIONS
(For Fabrication only)

BEAM	☉ S. Abut.	☉ Pier 1	Splice 1	Splice 2	☉ Pier 2	☉ N. Abut.
1	581.03	581.04	581.04	580.92	580.89	580.73
2	581.17	581.19	581.20	581.09	581.06	580.91
3	581.28	581.31	581.32	581.23	581.20	581.06
4	581.33	581.37	581.38	581.31	581.28	581.15
5	581.20	581.25	581.26	581.20	581.17	581.05
6	581.04	581.10	581.11	581.07	581.04	580.93
7	580.80	580.92	580.95	581.02	581.01	580.97
8	580.91	581.05	581.08	581.17	581.16	581.13
9	581.00	581.15	581.19	581.29	581.28	581.26
10	580.91	581.07	581.11	581.23	581.22	581.21
11	580.76	580.93	580.98	581.10	581.10	581.10
12	580.57	580.75	580.79	580.94	580.95	580.95

I_s, S_s : Non-composite moment of inertia and section modulus of the steel section used for computing f_s (Total and Overload) due to non-composite dead loads (in⁴ and in³).

$I_c(n), S_c(n)$: Composite moment of inertia and section modulus of the steel and deck based upon the modular ratio, "n", used for computing f_s (Total and Overload) due to short-term composite live loads (in⁴ and in³).

$I_c(3n), S_c(3n)$: Composite moment of inertia and section modulus of the steel and deck based upon 3 times the modular ratio, "3n", used for computing f_s (Total and Overload) due to long-term composite (superimposed) dead loads (in⁴ and in³).

Z : Plastic Section Modulus of the steel section in non-composite areas (in³).

$\bar{\rho}$: Un-factored non-composite dead load (kips/ft.).

$M\bar{\rho}$: Un-factored moment due to non-composite dead load (kip-ft.).

$s\bar{\rho}$: Un-factored long-term composite (superimposed) dead load (kips/ft.).

$M_s\bar{\rho}$: Un-factored moment due to long-term composite (superimposed) dead load (kip-ft.).

M_L : Un-factored live load moment (kip-ft.).

M_{Imp} : Un-factored moment due to impact (kip-ft.).

M_a : Factored design moment (kip-ft.).

M_u : Compact composite moment capacity according to AASHTO LFD 10.50.1.1 or compact non-composite moment capacity according to AASHTO LFD 10.48.1 (kip-ft.).

f_s (Overload): Sum of stresses as computed from the moments below (ksi).

f_s (Total): Sum of stresses as computed from the moments below on non-compact section (ksi).

VR : Maximum $\bar{\rho}$ + impact horizontal shear range within the composite portion of the span for stud shear connector design (kips).

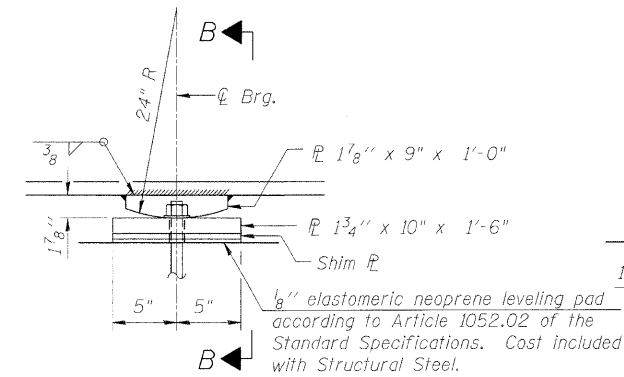

ELEVATION AT PIERS

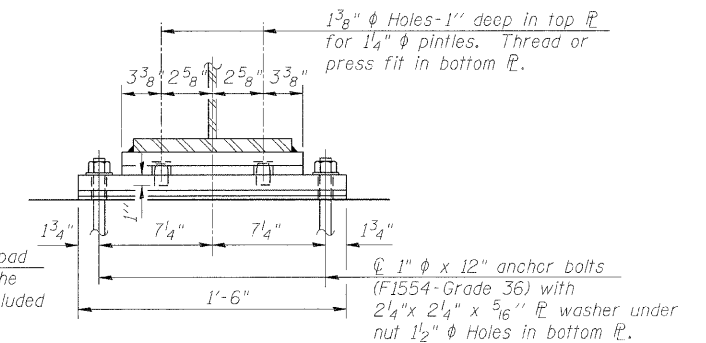

SECTION B-B

FIXED BEARING

(24 Required)

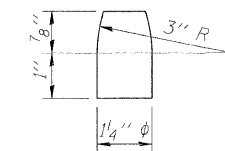

PINTLE

Notes:
Anchor bolts shall be ASTM F1554 all-thread (or an Engineer-approved alternate material) of the grade(s) and diameter(s) specified. ASTM A307 Grade C anchor bolts may be used in lieu of ASTM F1554 Grade 36 (Fy=36ksi). The corresponding specified grade of AASHTO M314 anchor bolts may be used in lieu of ASTM F1554.
Anchor bolts at fixed bearings may be either cast in place or installed in holes drilled after the supported member is in place.
Drilled and set anchor bolts shall be installed according to Article 521.06 of the Standard Specifications.

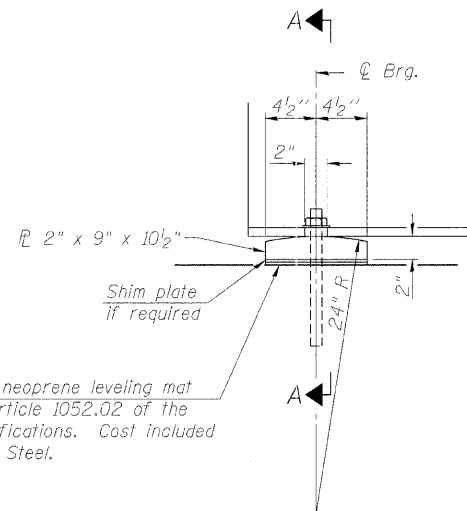

INTEGRAL ABUTMENT BEARINGS

(24 Required)

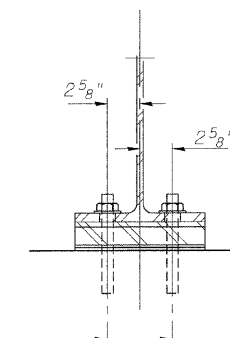

SECTION A-A

SHIM PLATE THICKNESS

Value provided is the total required height of shims

BEAM	S. Abut.	Pier 1	N. Abut.
4	5/8"	5/8"	
9			5/8"

BILL OF MATERIAL

Item	Unit	Total
Anchor Bolts, 1"	Each	96

NOTES

- For framing plan see Sheet No. 13
- For beam elevation see Sheet No. 14
- All steel for the bearings, except for anchor bolts or as noted otherwise, shall conform to the requirements of AASHTO M270 Grade 36.
- Two 1/8 in. adjusting shims shall be provided for each bearing in addition to all other plates or shims and placed as shown on bearing details.

STEEL DETAILS 2
IL ROUTE 92 (CENTENNIAL EXPRESSWAY)
OVER 31st AVENUE
FAP ROUTE 308 SEC. 1(HB-2)R
ROCK ISLAND COUNTY
STATION 1470+70.31
STRUCTURE NO. 081-0172 (SB)
STRUCTURE NO. 081-0173 (NB)

DESIGNED	CMM/JSD
CHECKED	JSD
DRAWN	EF
CHECKED	AMK

LOCHNER
H.W. LOCHNER, INC., CHICAGO, ILLINOIS

t:\2082\st-uc\tdgn\2044023BD1.dgn

STATE OF ILLINOIS
DEPARTMENT OF TRANSPORTATION

ROUTE NO. F.A.P. 308	SECTION *	COUNTY ROCK ISLAND	SHEET NO. 210	SHEET NO. 100	SHEET NO. 16 31 SHEETS
FED. ROAD DIST. NO. 7		ILLINOIS		FED. AID PROJECT-	

Contract #64814 * (1HB,HB-1,VB,HB-2)R

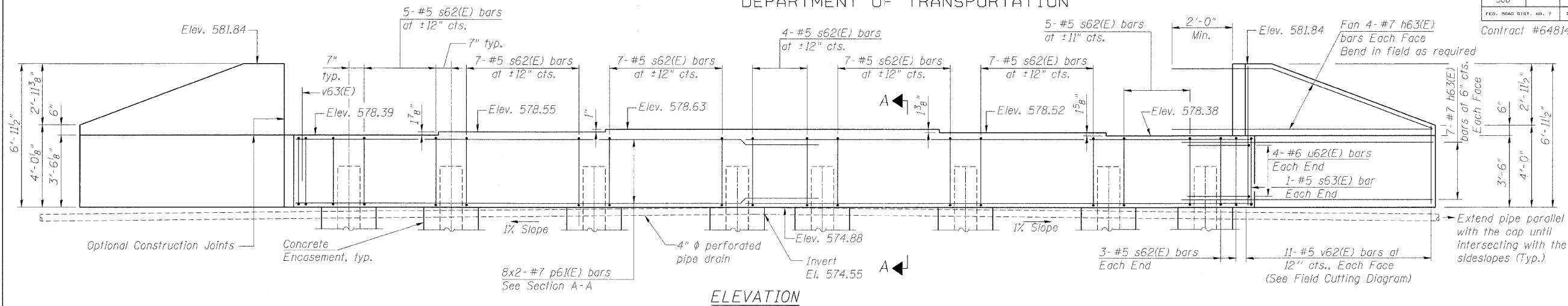

ELEVATION

MIN. BAR LAP
#7 bar = 4'-10"

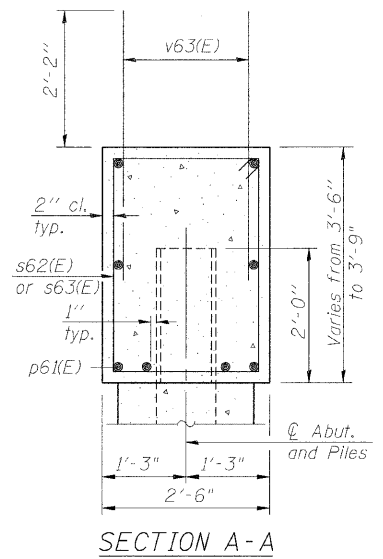

SECTION A-A

PILE DATA

Type: Steel-HP12x53 with pile shoes
Nominal Required Bearing: 419 k
Allowable Resistance Available: 140 k
Est. Length: 61 ft
No. Production Piles: 8
No. Test Piles: 0

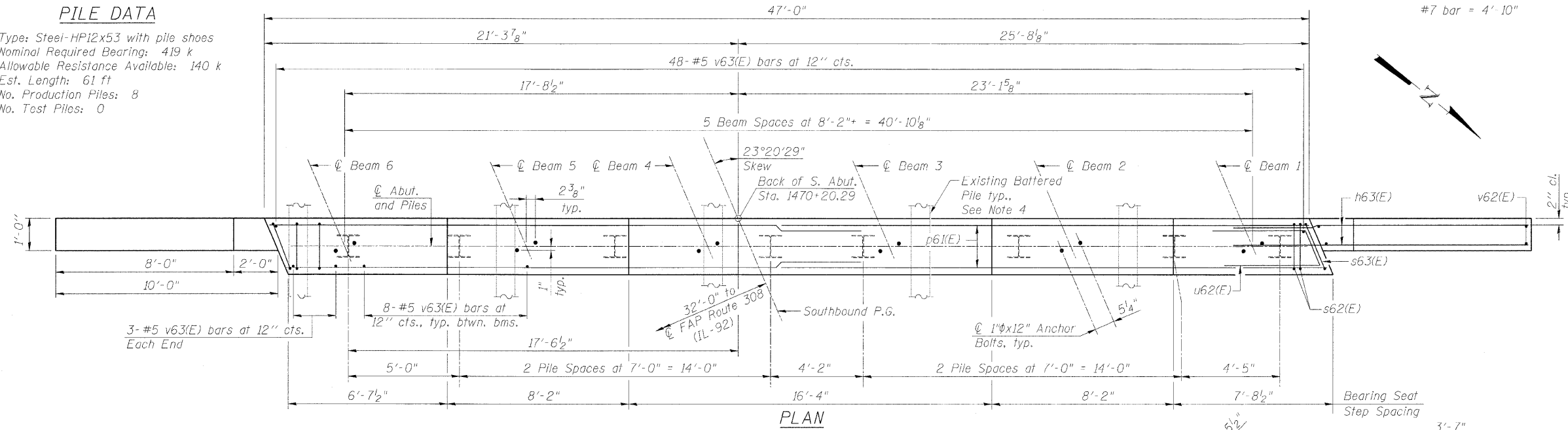

PLAN

BILL OF MATERIAL

Bar	No.	Size	Length	Shape
h63(E)	44	#7	11'-10"	
p61(E)	16	#7	25'-9"	
s62(E)	48	#5	11'-7"	
s63(E)	2	#5	12'-1"	
u62(E)	8	#6	9'-5"	
v62(E)	22	#5	10'-4"	
v63(E)	94	#5	4'-4"	
Porous Granular Embankment (Special) Cu. Yd. 68				
Structure Excavation Cu. Yd. 37				
Concrete Structures Cu. Yd. 20.2				
Reinforcement Bars, Epoxy Coated Pound 3,290				
Furnishing Steel Piles HP12x53 Foot 488				
Driving Piles Foot 488				
Pile Shoes Each 8				
Concrete Encasement Cu. Yd. 2.8				
Geocomposite Wall Drain Sq. Yd. 43				
Pipe Underdrains for Structures 4" Foot 85				

* Included in the cost of Pipe Underdrains for Structures, 4"

Note:
All Drainage system components shall extend to 2'-0" from the end of each wingwall except an outlet pipe shall extend until intersecting with the side slopes. The pipes shall drain into concrete headwalls. (See Article 601.05 of the Standard Specifications and Highway Standard 601101).

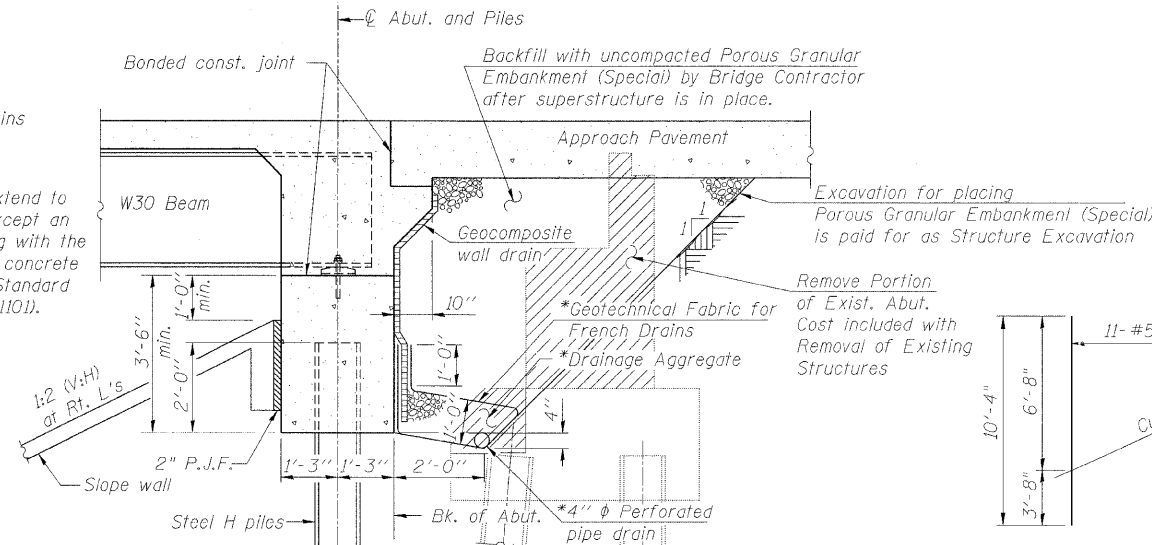

SECTION THRU ABUTMENT
(Horiz. dim. @ Rt. L's)

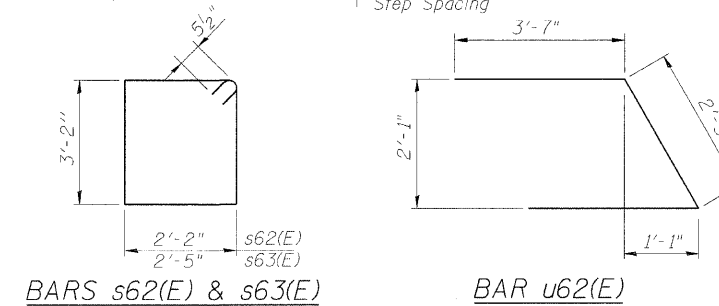

BARS s62(E) & s63(E)

BAR u62(E)

NOTES

- For details of Bar Splicers, see Sheet No. 23
- For details of piles and Concrete Encasement, see Sheet No. 22
- Bars indicated thus 8x2-#7 etc. indicates 8 lines of bars with 2 lengths per line.
- The Contractor shall verify the locations of existing piles before driving new piles.
- Excavation required for Concrete Encasements shall be included in the cost of Concrete Encasement.
- Pour steps monolithically with cap.
- For shim plates and bearing details, see Sheet No. 15
- For abutment diaphragm details, see Sheet No. 10

FIELD CUTTING DIAGRAM

Order v62(E) full length. Cut as shown and use remainder of bars in opposite face.

DESIGNED	AMK
CHECKED	JSD
DRAWN	EF
CHECKED	RWC

LOCHNER
H.W. LOCHNER, INC., CHICAGO, ILLINOIS

SOUTH ABUTMENT (SB)
IL ROUTE 92 (CENTENNIAL EXPRESSWAY)
OVER 31st AVENUE
FAP ROUTE 308 SEC. 1(HB-2)R
ROCK ISLAND COUNTY
STATION 1470+70.31
STRUCTURE NO. 081-0172 (SB)
STRUCTURE NO. 081-0173 (NB)