

STATE OF ILLINOIS
DEPARTMENT OF TRANSPORTATION

ROUTE NO.	SECTION	COUNTY	TOTAL SHEETS	SHEET	SHEET NO.
F.A.S. 1832	5BR-2	WASHINGTON	97	72	12 SHEETS
FED. ROAD DIST. NO. 7	ILLINOIS		FED. AID PROJECT-		

Contract #76949

GENERAL NOTES

Reinforcement bars shall conform to the requirements of ASTM A 706 Gr 60 (IL Modified). See Special Provisions.
Reinforcement bars designated (E) shall be epoxy coated.
The option of using a precast footing is not allowed.
Layout of slope protection system may be varied in the field to suit ground conditions as directed by the Engineer.
After the keyways have been grouted and cured, the joints on the three sides of the structure shall be externally sealed using 13" wide external sealing bands conforming to Article 1057.01. Cost included with Three-Sided Precast Concrete Structures.

The footing design is based on the following maximum reactions applied at the top of the footing:

Vertical 15.4 k/ft
Horizontal 6.3 k/ft

The contractor shall verify that the selected structure meets these design parameters. If the design parameters are exceeded, a complete footing design with calculations, details, signed and sealed by an Illinois Licensed Structural Engineer shall be submitted for review and approval.

All construction joints shall be bonded.
Excavation behind existing abutment walls shall be performed to balance front and back soil pressure before removing the existing superstructure. The Contractor shall sawcut the upper portion of the existing abutment at the stage removal line before Stage I removal to ensure the remaining portion will not be prematurely damaged.

Dimensions for the Three-Sided Precast are for a Con Span section. Hy-Span, REDI-SPAN Bridge System and BEBO-Arch System are also acceptable, but dimensions may vary.

It shall be the responsibility of the Contractor to divert the stream flow during construction in order to keep the construction areas free of water. The method of water diversion shall be subject to the approval of the Engineer and the cost shall be included with the cost of "Concrete Structures".

Structural Seal does not include design of Precast elements.
For backfilling and embankment, see Standard Specifications.
All exposed edges shall be chamfered 3/4".
Allowable Bearing Pressure for Footing = 4 ksf.

TOTAL BILL OF MATERIAL

ITEM	UNIT	SUPER	SUB	TOTAL
Removal of Existing Structures No. 2	Each			1
Name Plates	Each	1		1
Stone Riprap, Class A5	Sq. Yd.			340
Filter Fabric	Sq. Yd.			340
Concrete Structures	Cu. Yd.		145.0	145.0
Reinforcement Bars, Epoxy Coated	Pound		6590	6590
Bar Splicers	Each		28	28
Structure Excavation	Cu. Yd.		365	365
Three Sided Precast Concrete Structure, 28' x 9'	Foot	37.25		37.25
Temporary Soil Retention System	Sq. Ft.			444.1
Steel Rail, Type 2399	Foot	64		64
Geotextile Retaining Wall	Sq. Ft.			1763
Precast Concrete Substructure	L. Sum		1	1
Concrete Sealer	Sq. Ft.	144		144

STAGE CONSTRUCTION DETAILS
F.A.S. RTE. 1832 - SEC. 5BR-2
WASHINGTON COUNTY
STATION 1511+01.00
STRUCTURE NO. 095-0078

Rev. 2-19-08

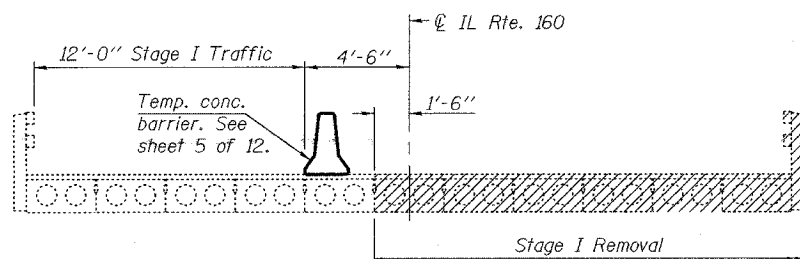

STAGE I REMOVAL

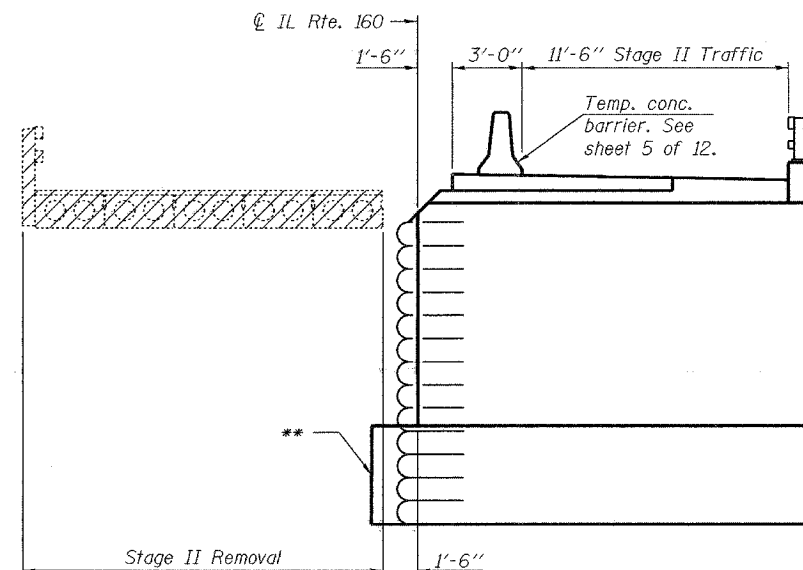

STAGE II REMOVAL

(Looking East at New West footing at Rt. L to Footing)

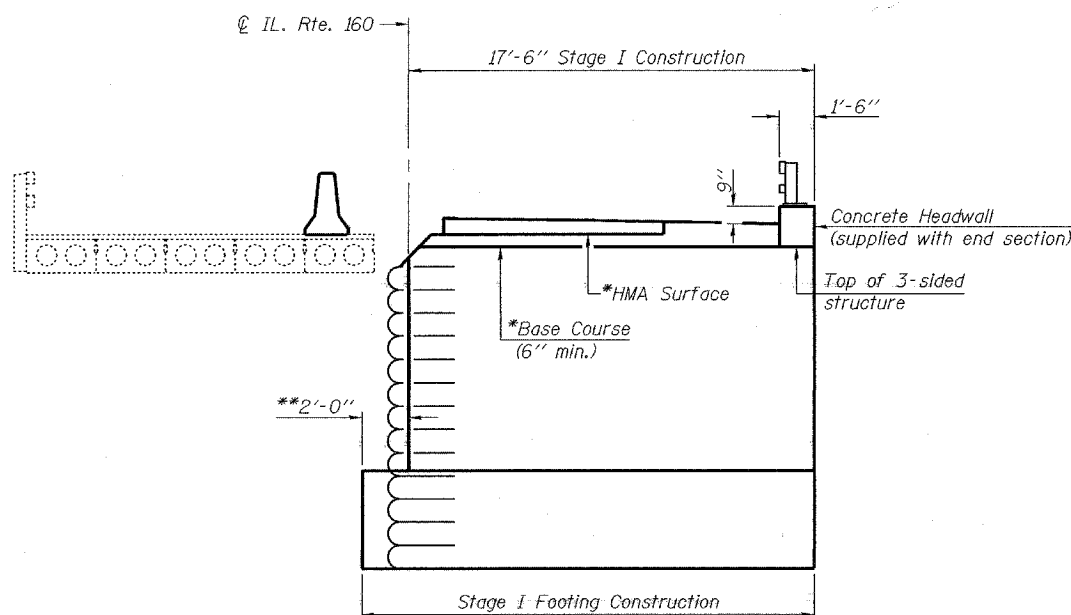

STAGE I CONSTRUCTION

(Looking East at New West footing at Rt. L to Footing)

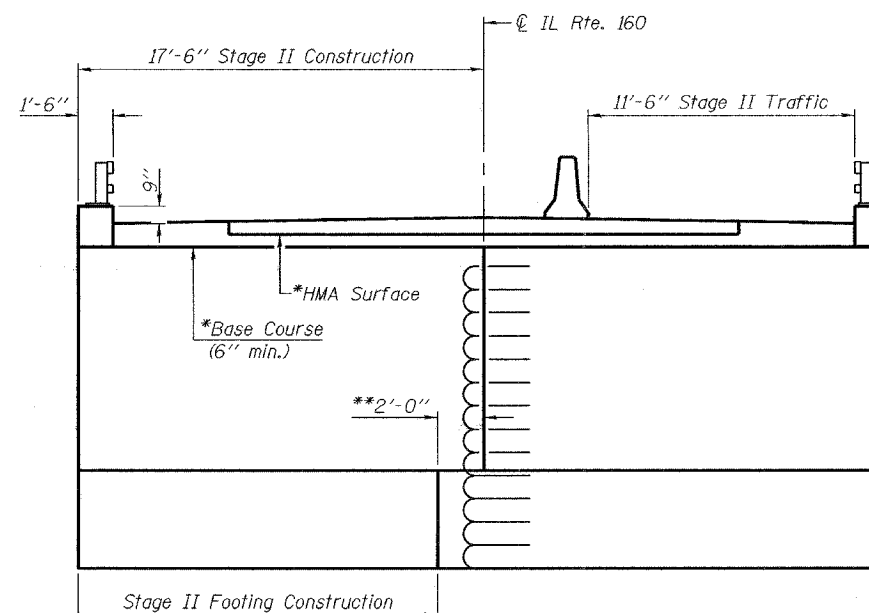

STAGE II CONSTRUCTION

(Looking East at New West footing at Rt. L to Footing)

*For quantities of HMA Surface and Base Course, see Roadway Plans.
**Stage I west footing to be constructed 2'-0" @ Rt. L to CL IL Rte. 160 into Stage II Construction.

Note: For quantity of Temporary Concrete Barrier, see Roadway Plans.

DESIGNED	Nicholas R. Barnett
CHECKED	Ray Ahanchi
DRAWN	Gregory D. Farmer
CHECKED	NRB/GRA

EXAMINED	January 28 2008
PASSED	Thomas J. Demagalaki ENGINEER OF BRIDGE DESIGN
	Ralph E. Anderson ENGINEER OF BRIDGES AND STRUCTURES