

PROPOSED IL 161
 STA. 181+00 TO STA. 314+00
 STA. 330+00 TO STA. 481+00

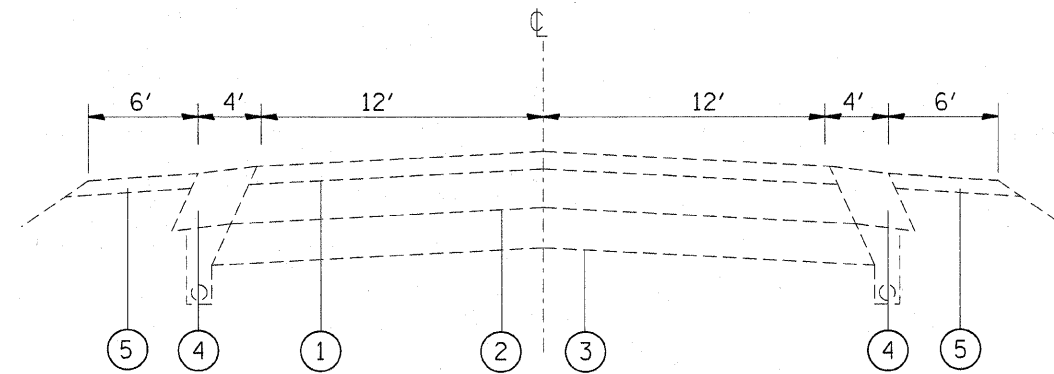

EXISTING IL 161
 STA. 181+00 TO STA. 481+00

LEGEND

- ① EXISTING BITUMINOUS BINDER AND SURFACE COURSE ± 4 1/4"
- ② EXISTING P.C.C. PAVEMENT
- ③ EXISTING STABILIZED SUB BASE
- ④ EXISTING STABILIZED SHOULDER (8")
- ⑤ EXISTING AGGREGATE SHOULDER TYPE B
- ⑥ PROPOSED HMA SURFACE REMOVAL 1 1/2"
- ⑦ PROPOSED LEVELING BINDER 3/4"
- ⑧ PROPOSED HMA SURFACE COURSE 1 1/2"
- ⑨ PROPOSED HMA SHOULDERS 8"
- ⑩ PROPOSED AGGREGATE WEDGE, TYPE B
- ⑪ PROPOSED HMA BINDER COURSE, 10 3/4"
- ⑫ PROPOSED LIME MODIFIED SOIL, 12"
- ⑬ PROPOSED PIPE UNDERDRAINS 6"
- ⑭ PROPOSED AGGREGATE SHOULDER, TYPE A 6"
- ⑮ PROPOSED BITUMINOUS MATERIAL (PRIME COAT)
- ⑯ PROPOSED AGGREGATE MATERIAL (PRIME COAT)
- ⑰ PROPOSED STRIP REFLECTIVE CRACK CONTROL

*WE ARE CORRECTING THE EXISTING 5 TO 6% SHOULDER SLOPES TO 4%.

FILE NAME =	USER NAME = #USER#	DESIGNED - ---	REVISED - ---	STATE OF ILLINOIS DEPARTMENT OF TRANSPORTATION	TYPICAL SECTION	F.A.P. RTE.	SECTION	COUNTY	TOTAL SHEETS	SHEET NO.	
①FILEL#		DRAWN - ---	REVISED - ---			805	(101,102,61-1-1)RS	MARTON	81	8	
	PLOT SCALE = #SCALE#	CHECKED - ---	REVISED - ---			CONTRACT NO. 76833					
	PLOT DATE = #DATE#	DATE - ---	REVISED - ---			FED. ROAD DIST. NO. - [ILLINOIS] FED. AID PROJECT					
						SCALE: _____ SHEET NO. ___ OF ___ SHEETS STA. _____ TO STA. _____					