

FILE NO.	SECTION	COUNTY	TOTAL SHEETS	SHEET NO.
*	06-00132-00-PK	WILL	15	10
STA.	..*	TO STA.	*	*
		WORK		

CONTRACT NUMBER 83974

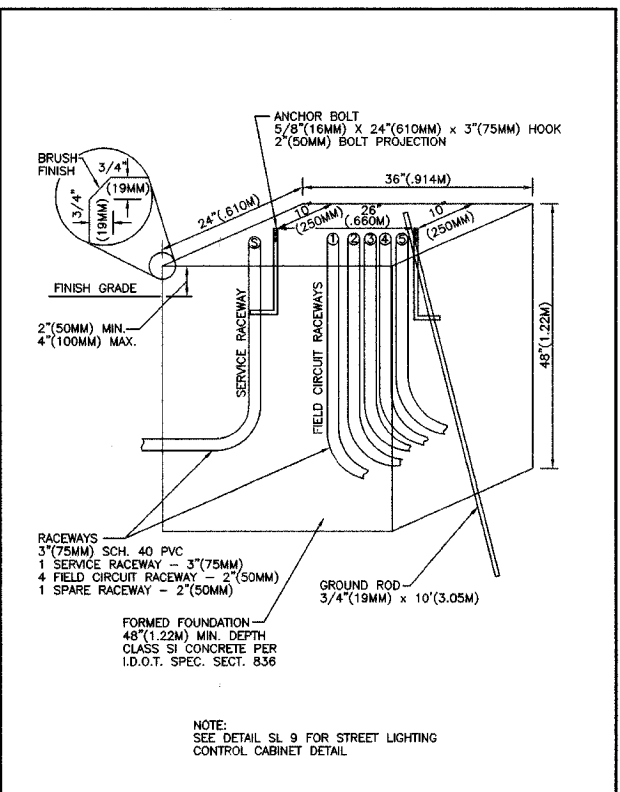
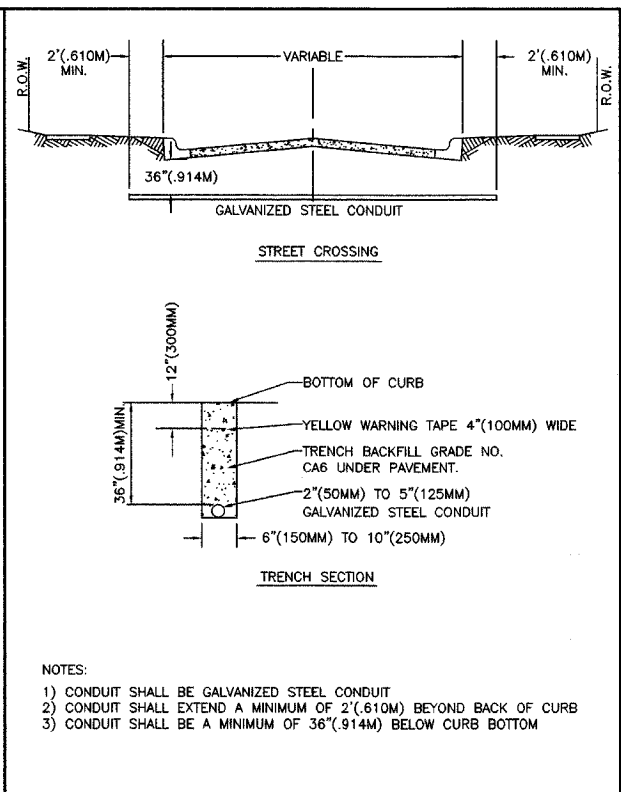
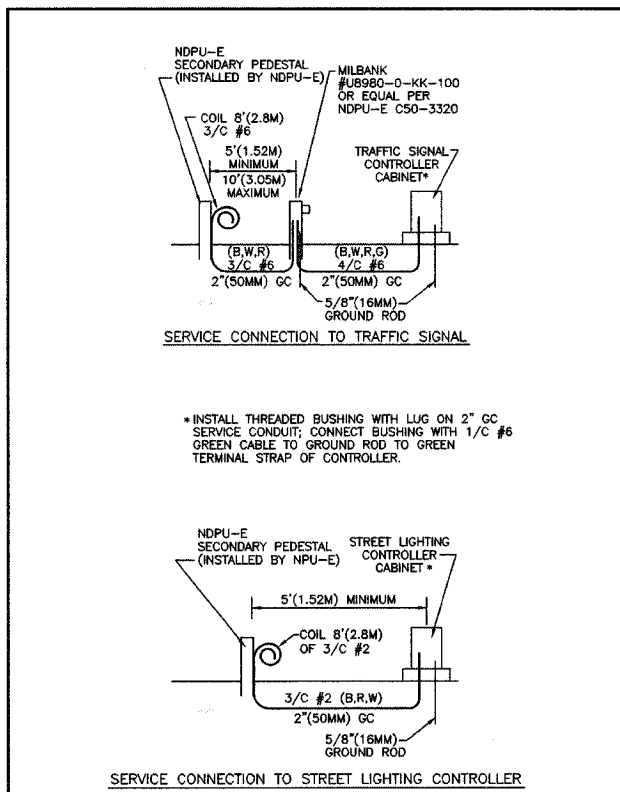

Title: TYPICAL STREET LIGHT CONNECTION	CITY OF NAPERVILLE STANDARD DETAIL
Approved By:	DATE: 5/3/00 REV: Detail: SL 4

Title: ELECTRIC CONDUIT UNDER PAVEMENT	CITY OF NAPERVILLE STANDARD DETAIL
Approved By:	DATE: 4/19/99 REV: Detail: SL 6

Title: I.D.O.T. TYPE III STREET LIGHTING CONTROL CABINET FOUNDATION	CITY OF NAPERVILLE STANDARD DETAIL
Approved By:	DATE: 2/22/00 REV: Detail: SL 7

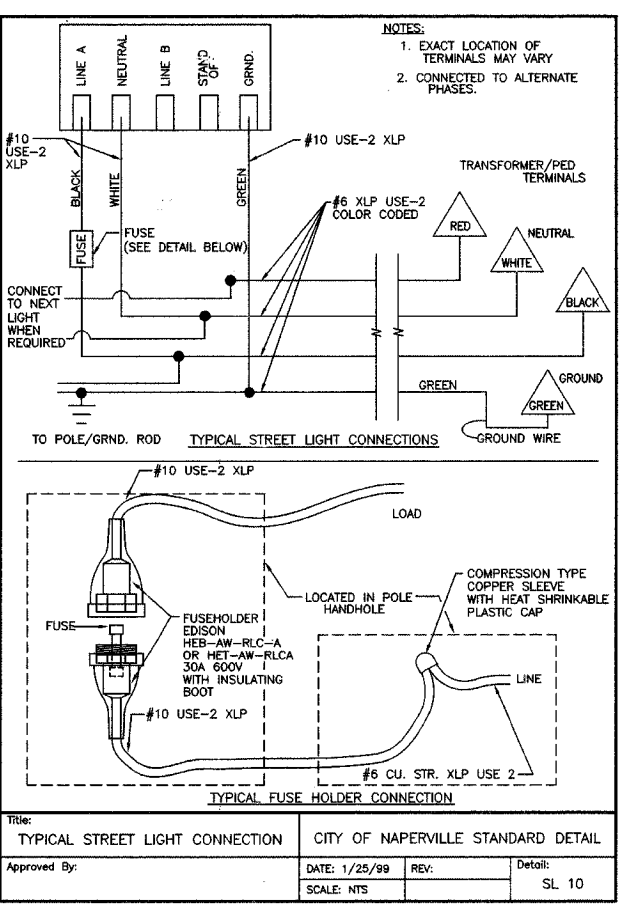
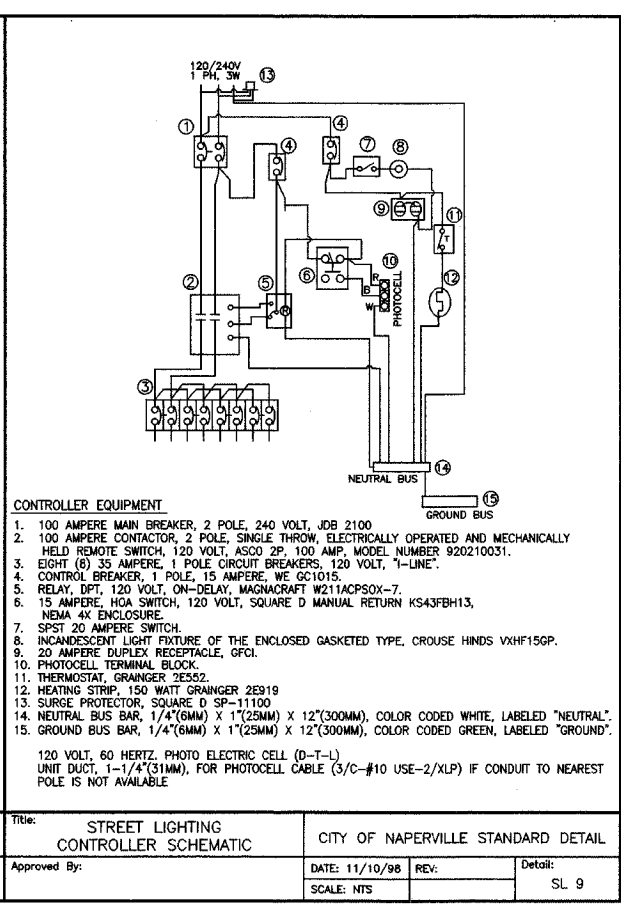
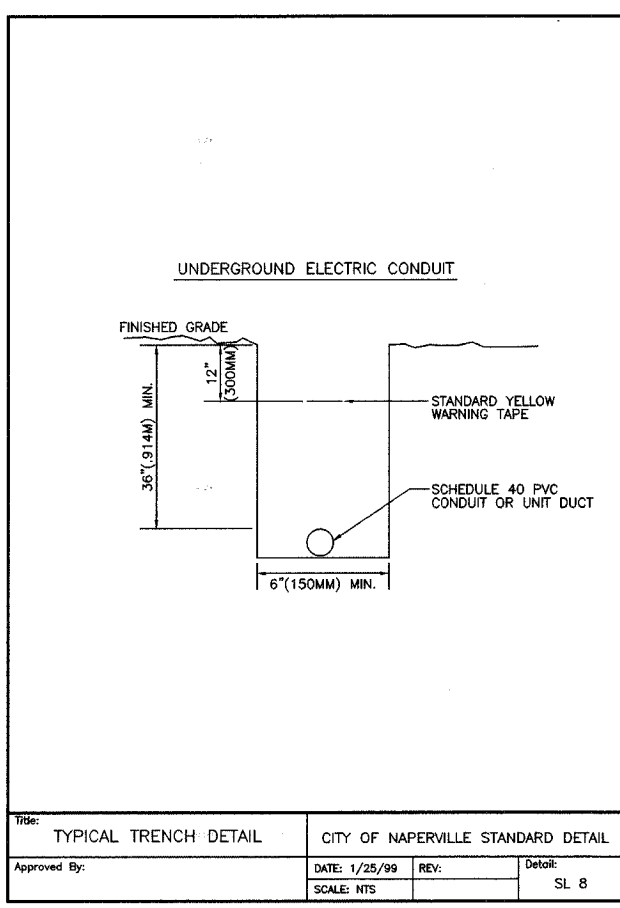
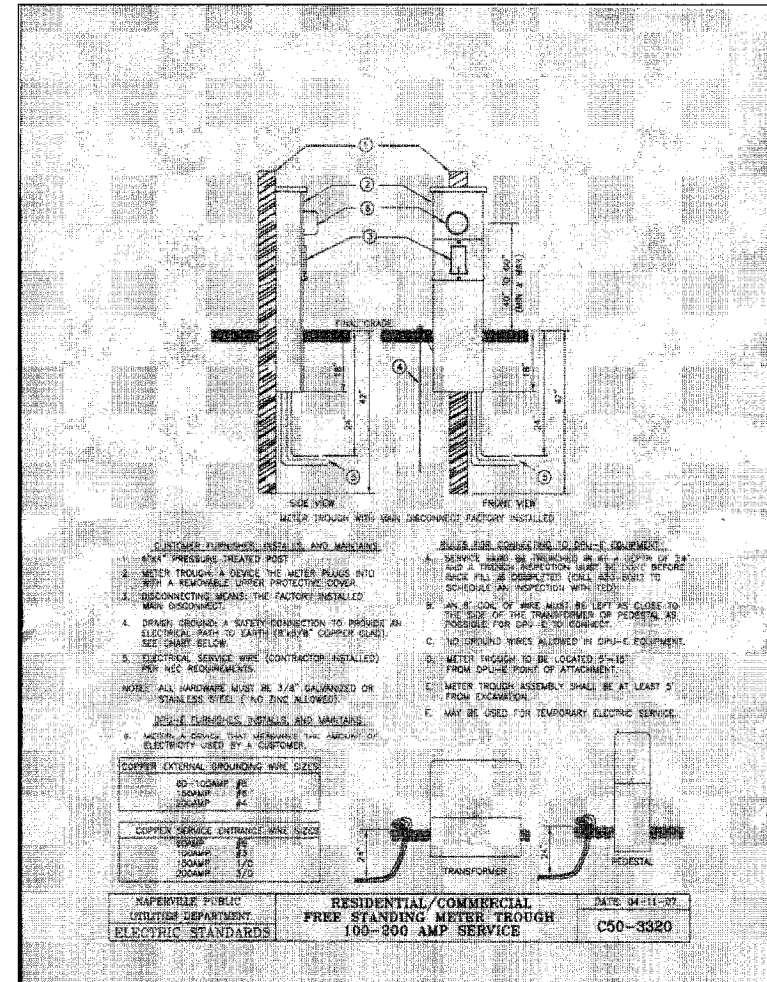

NOTE:
 A CITY OF NAPERVILLE BUILDING PERMIT IS REQUIRED.

REVISIONS	
NAME	DATE
PRE-FINAL SUBMITTAL	05.31.07
FINAL SUBMITTAL	08.31.07

CITY OF NAPERVILLE

LIGHTING PLAN DETAIL

95TH STREET PARK AND RIDE

DATE: 11/26/2007
 DESIGNED BY: DNM
 TECHNICIAN: SJC
 CHECKED BY: JRV