

Proposed Typical Cross Section #1
Station 50+35.64 to Station 56+59.44
Polk Avenue to Tyler Avenue

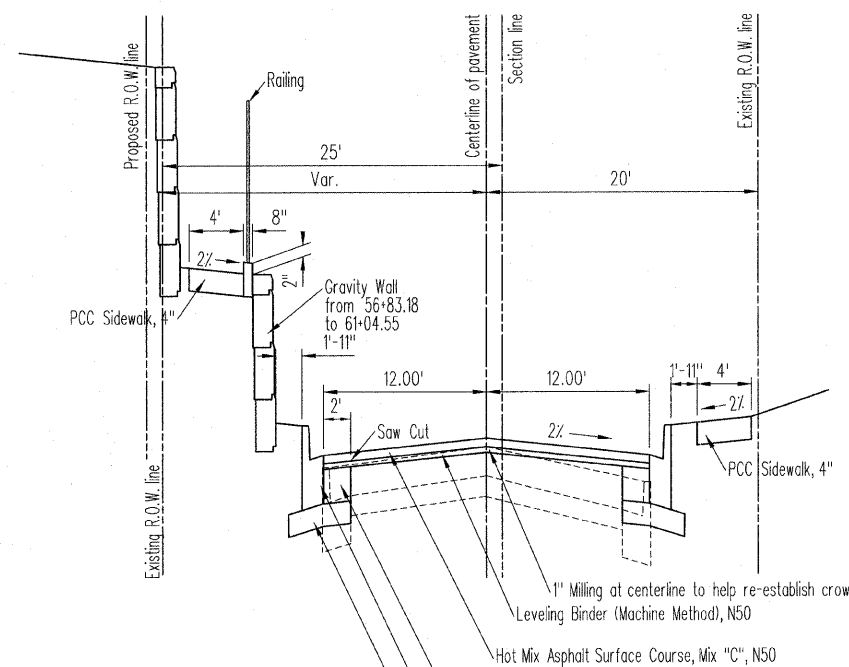

Proposed Typical Cross Section #2
Station 56+59.44 to Station 63+26.71
Tyler Avenue to Harrison Avenue

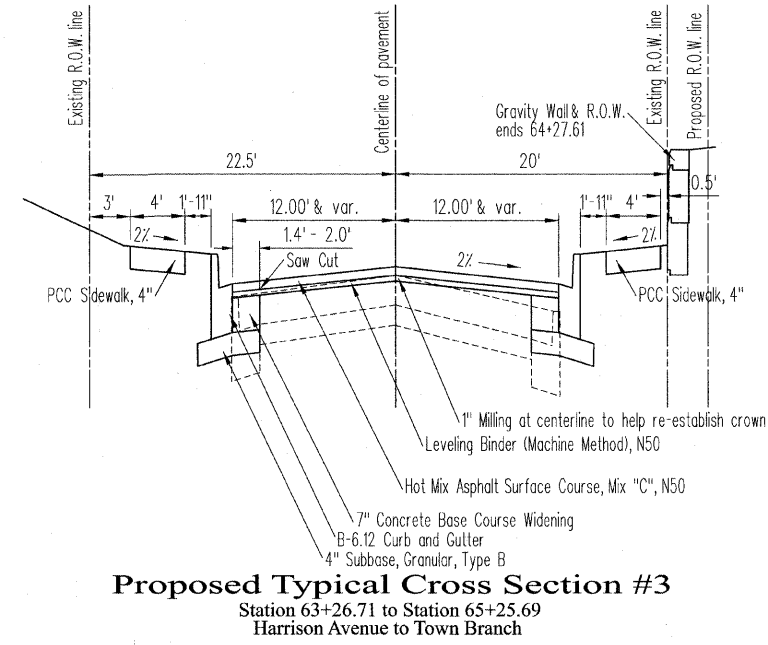

Proposed Typical Cross Section #3
Station 63+26.71 to Station 65+25.69
Harrison Avenue to Town Branch

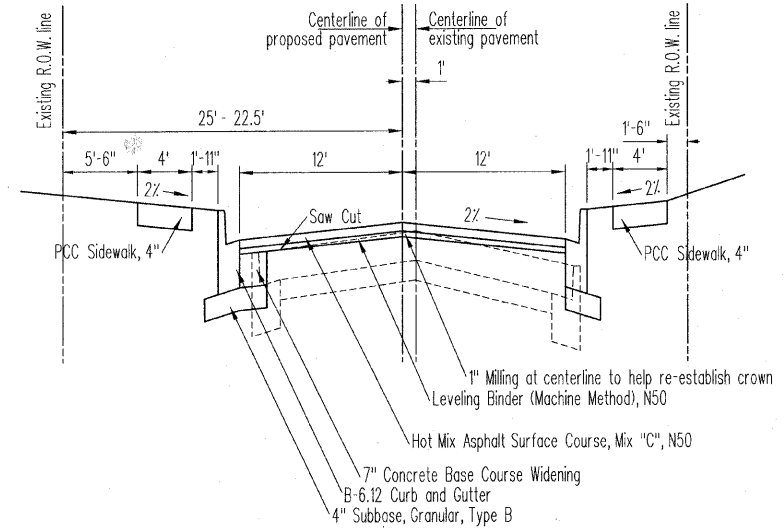

Proposed Typical Cross Section #4
Station 66+54.68 to Station 70+26.03
Town Branch to Van Buren Avenue

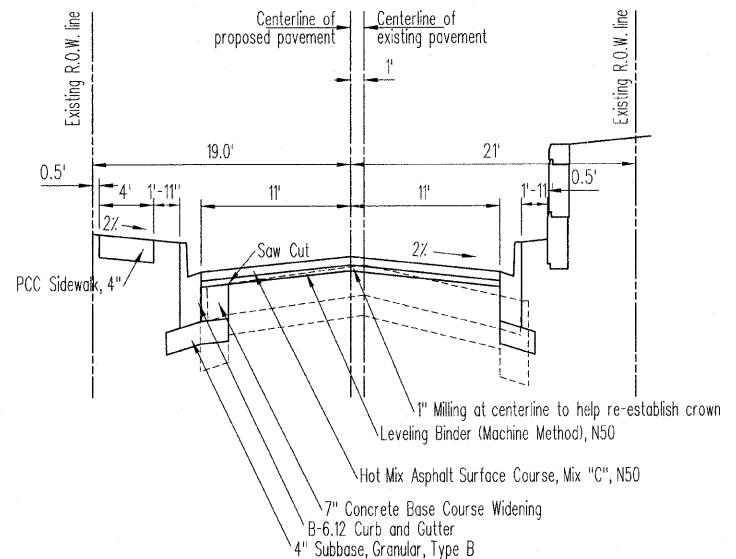

Proposed Typical Cross Section #5
Station 70+26.03 to Station 73+50.00
Van Buren Avenue to Jackson Avenue

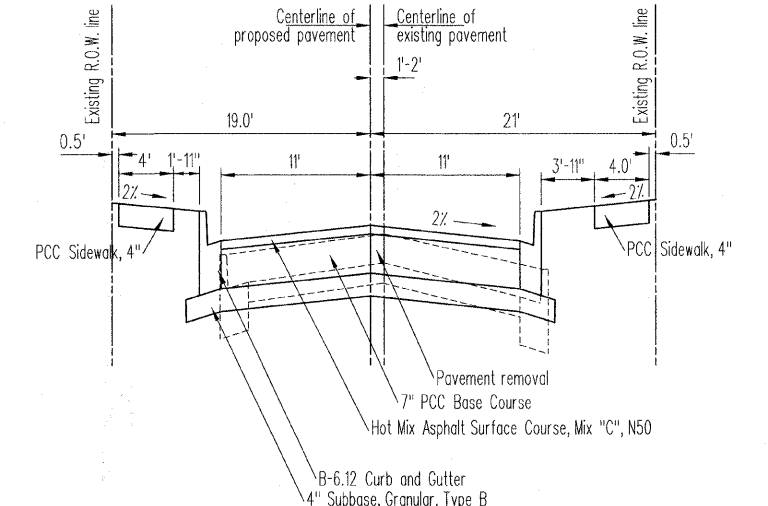

Proposed Typical Cross Section #6
Station 73+50.00 to Station 78+20.00
Jackson Avenue to Madison Avenue

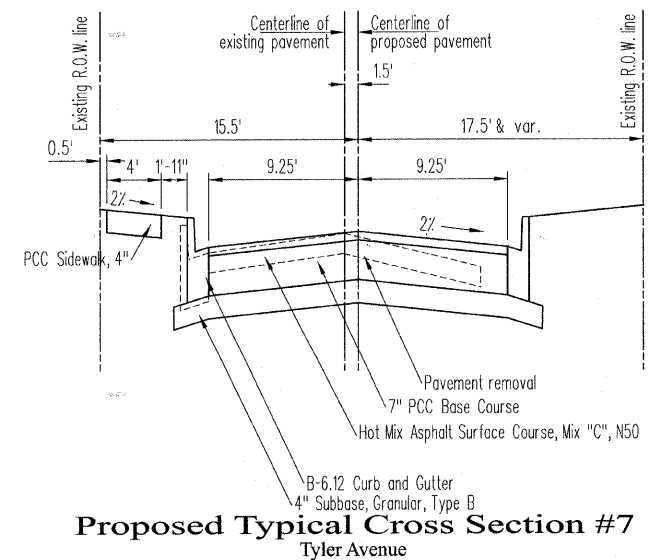

Proposed Typical Cross Section #7
Tyler Avenue

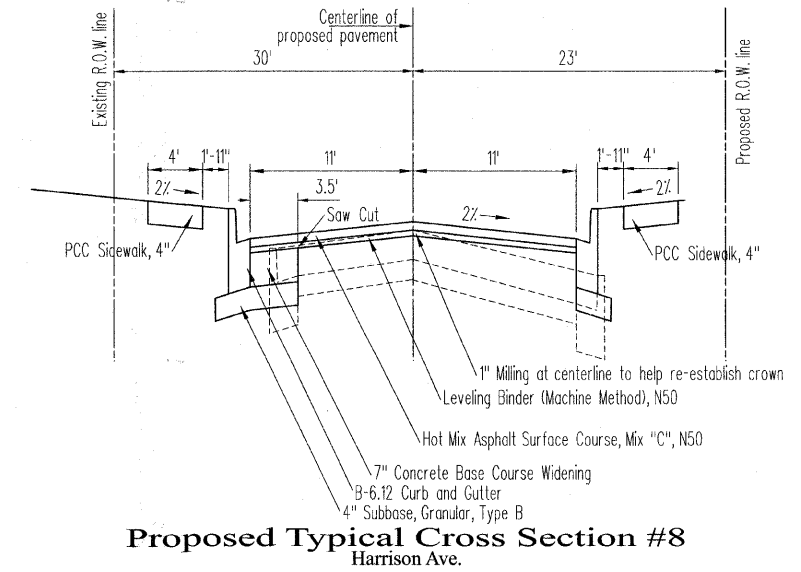

Proposed Typical Cross Section #8
Harrison Ave.

DCR	DRAWN DATE	CHECKED DATE	APPROVED DATE	REVISED DATE

SCALES	N/A

4th Street
Proposed
Typical Sections