

EXISTING PAVEMENT TYPICAL SECTION

OXFORD LANE
STA 48+41

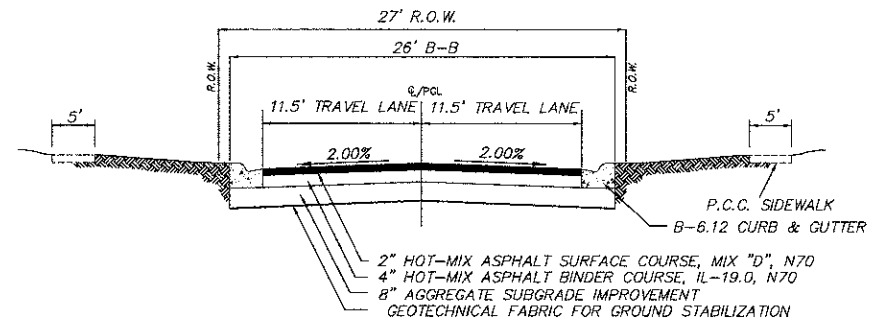

PROPOSED RECONSTRUCTION TYPICAL SECTION

OXFORD LANE
STA 48+41

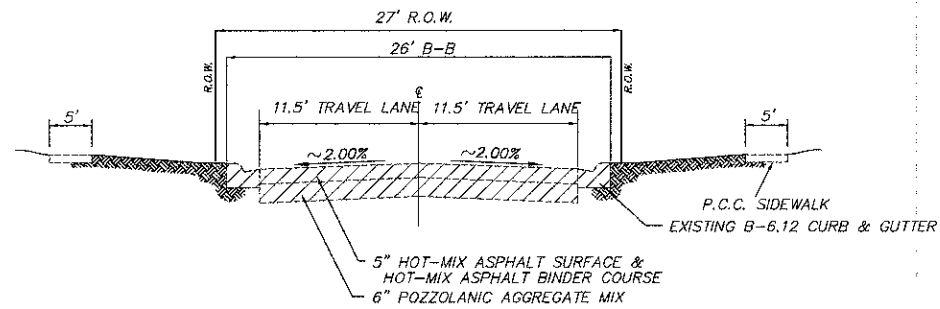

EXISTING PAVEMENT TYPICAL SECTION

GEORGETOWN LANE
STA 50+57

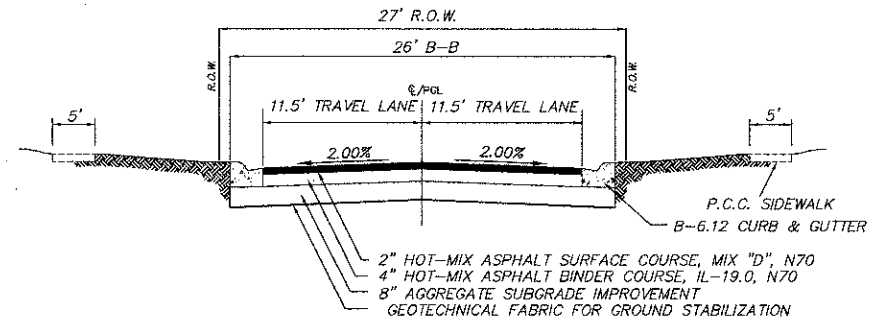

PROPOSED RECONSTRUCTION TYPICAL SECTION

GEORGETOWN LANE
STA 50+57

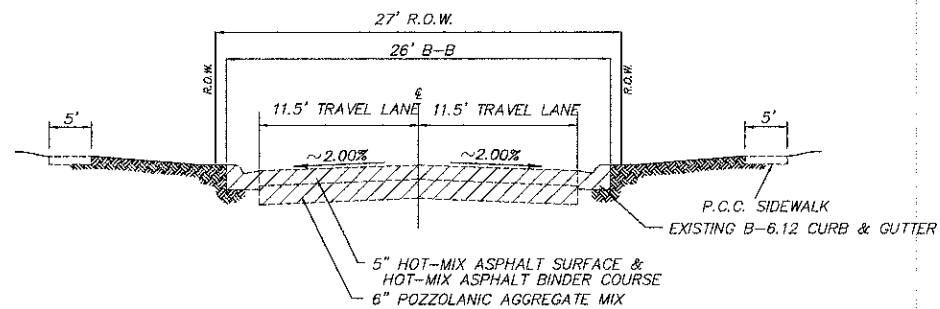

EXISTING PAVEMENT TYPICAL SECTION

ERIE LANE
STA 52+68

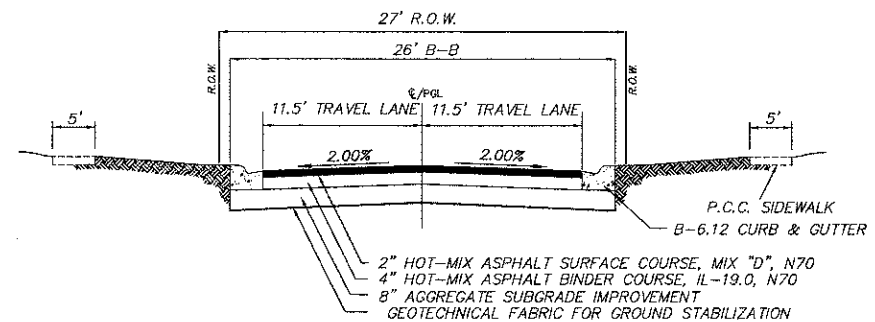

PROPOSED RECONSTRUCTION TYPICAL SECTION

ERIE LANE
STA 52+68

LEGEND

 REMOVAL

ERIE LANE, GEORGETOWN LANE, OXFORD LANE

HOT-MIX ASPHALT MIXTURE REQUIREMENT	
MIXTURE TYPE	AIR VOIDS @ Ndes
FULL DEPTH PAVEMENT	
HOT-MIX ASPHALT SURFACE COURSE, MIX "D", N70 (IL-9.5 mm); 2"	4% @ 70 GYR
HOT-MIX ASPHALT BINDER COURSE, IL-19.0 N70; 4"	4% @ 70 GYR

NOTE: THE UNIT WEIGHT USED TO CALCULATE ALL HOT-MIX ASPHALT SURFACE MIXTURES IS 112 LBS/SQ YD/IN. THE "AC TYPE" FOR POLYMERIZED HMA MIXES SHALL BE "SBS/SBR PG 76-22" AND FOR NON POLYMERIZED HMA SHALL BE "PG 64-22" UNLESS MODIFIED BY DISTRICT ONE SPECIAL PROVISIONS. FOR USE OF RECYCLED MATERIALS SEE DISTRICT ONE SPECIAL PROVISIONS.

FILE NAME = DETAILSH.DWG	DESIGNED —	REVISED —
	DRAWN —	REVISED —
	CHECKED —	REVISED —
	DATE —	REVISED —

STATE OF ILLINOIS
DEPARTMENT OF TRANSPORTATION

Hassell Road STP Project
Typical Section

SCALE: NONE SHEET NO. 5 OF 7 SHEETS STA. TO STA.

F.A.U. RTE.	SECTION	COUNTY	TOTAL SHEETS	SHEET NO.
1100	11-00087-00-FP	Cook	164	12
CONTRACT NO. 63770				
ILLINOIS FED. AID PROJECT GMM 9003(757)				