

INDEX OF SHEETS

- 1 TITLE SHEET
- 2-3 GENERAL NOTES AND LEGEND
- 4-7 SUMMARY OF QUANTITIES
- 8-14 TYPICAL SECTIONS
- 15-30 PLAN AND PROFILE
- 31-48 CONSTRUCTION TRAFFIC STAGING AND DETOUR PLAN
- 49-56 EROSION & SEDIMENT CONTROL PLAN
- 57-72 DRAINAGE & UTILITIES PLAN AND PROFILE
- 73-81 STRIPING & SIGNAGE PLAN
- 82-89 LANDSCAPING
- 90-96 DISTRICT ONE STANDARD TRAFFIC SIGNAL DESIGN DETAILS
- 97 TRAFFIC SIGNAL MODIFICATION PLAN
- 98 TRAFFIC SIGNAL CABLE PLAN
- 99-107 STRUCTURE PLANS - SN 016-6328
- 108-114 STRUCTURE PLANS - SN 016-6344
- 115-121 STRUCTURE PLANS - SN 016-6343
- 122-124 ROADWAY SOIL BORING LOGS
- 125-137 DETAIL SHEETS
- 138-164 CROSS SECTIONS

FOR LIST OF HIGHWAY STANDARDS, SEE SHEET NO. 2

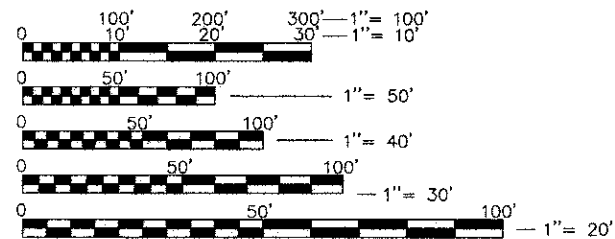

FULL SIZE PLANS HAVE BEEN PREPARED USING STANDARD ENGINEERING SCALES. REDUCED SIZED PLANS WILL NOT CONFORM TO STANDARD SCALES. IN MAKING MEASUREMENTS ON REDUCED PLANS, THE ABOVE SCALES MAY BE USED.

J.U.L.I.E.
JOINT UTILITY LOCATION INFORMATION FOR EXCAVATION
1-800-892-0123
OR 811

Program and Office Engineer: Charles F Riddle, P.E. (847) 705-4406 Schaumburg, IL
Project Engineer: Gary Salavitch, P.E. (847) 252-5800 Hoffman Estates, IL

STATE OF ILLINOIS
DEPARTMENT OF TRANSPORTATION
DIVISION OF HIGHWAYS

PLANS FOR PROPOSED
FEDERAL AID HIGHWAY
FAU ROUTE 1100 (HASSELL ROAD)
BARRINGTON ROAD TO FAIRWAY COURT
PAVEMENT RECONSTRUCTION
SECTION NO. 11-00087-00-FP
PROJECT NO. M-9003(757)
VILLAGE OF HOFFMAN ESTATES
COOK COUNTY
JOB NO. C-91-257-11

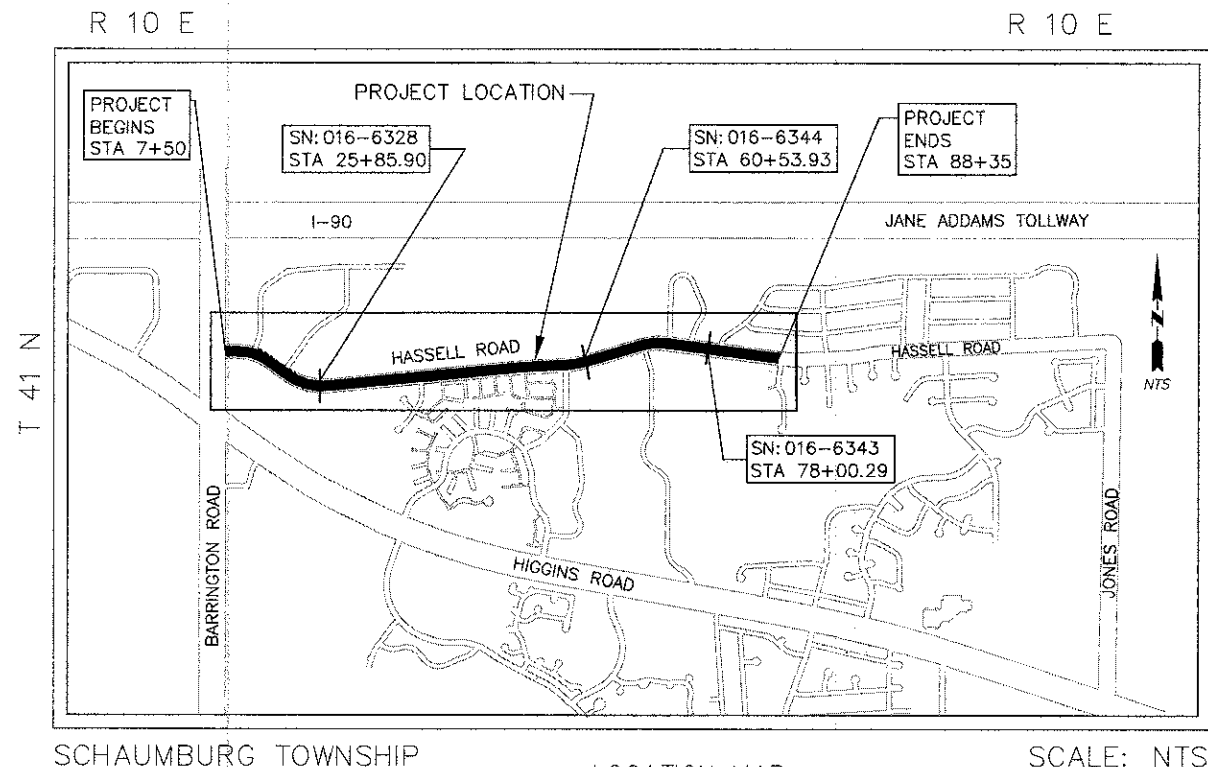
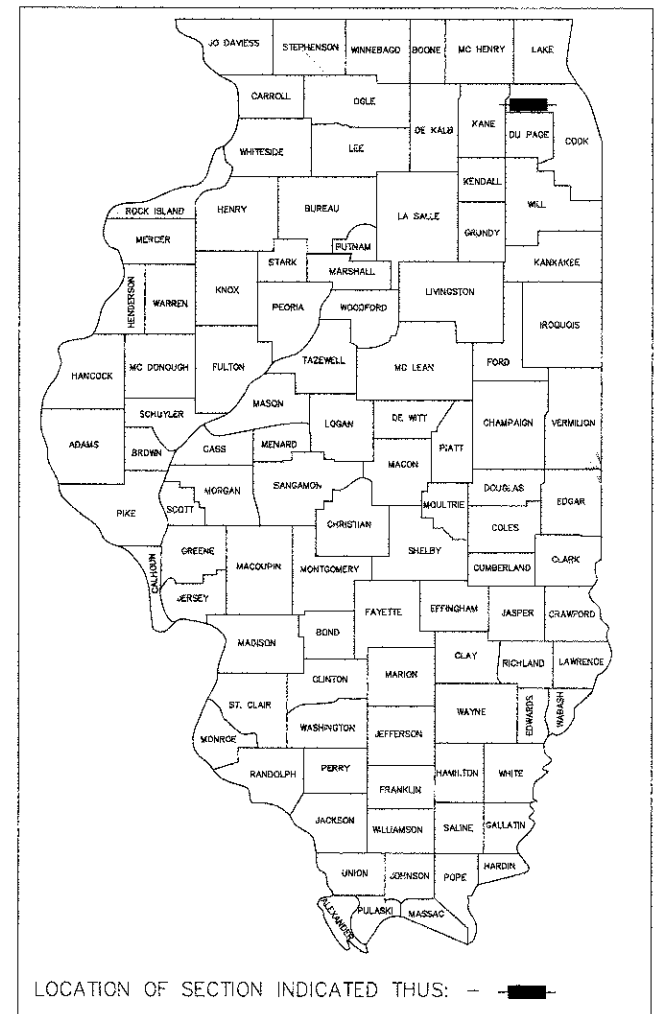

SCHAUMBURG TOWNSHIP LOCATION MAP SCALE: NTS

GROSS LENGTH = 8,085 LIN. FT. (1.53 MILES)
NET LENGTH = 7,563 LIN. FT. (1.43 MILES)

HASSELL ROAD
COLLECTOR
2040 ADT=6,000-11,000
SPEED LIMIT (POSTED): 25/30 MPH
SPEED LIMIT (DESIGN): 30 MPH

STATE OF ILLINOIS
DEPARTMENT OF TRANSPORTATION
DIVISION OF HIGHWAYS

APPROVED December 14, 2012
Gary Salavitch
VILLAGE OF HOFFMAN ESTATES, DIRECTOR OF ENGINEERING

PASSED DECEMBER 21, 2012
C. J. Holt
DISTRICT 1 ENGINEER OF LOCAL ROADS & STREETS

Releasing for Bid
Based on Limited Review December 21, 2012
Adam Fortmann
DEPUTY DIRECTOR OF HIGHWAYS, REGION 1 ENGINEER

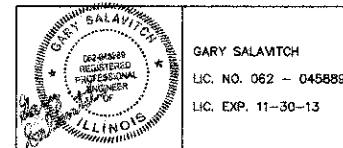

PRINTED BY THE AUTHORITY OF THE STATE OF ILLINOIS

GENERAL NOTES

1. ITEMS OF WORK LISTED IN THE SUMMARY OF QUANTITIES WHICH ARE NOT SPECIFICALLY INDICATED IN THE PLANS SHALL BE PERFORMED AT LOCATIONS AS DIRECTED BY THE ENGINEER.
2. THE ENGINEER SHALL NOT ASSUME ANY OF THE RESPONSIBILITIES OF THE CONTRACTOR'S SUPERINTENDENT OR OF SUBCONTRACTORS. ADDITIONALLY, THE ENGINEER SHALL NOT ADVISE ON, OR ISSUE DIRECTIONS CONCERNING ASPECTS OF CONSTRUCTION MEANS, METHODS, TECHNIQUES, SEQUENCES OF PROCEDURES, OR SAFETY PRECAUTIONS AND/OR PROGRAMS IN CONNECTION WITH THE WORK.
3. THE LOCATION OF PUBLIC AND PRIVATE UTILITIES SHOWN ON THE PLANS ARE APPROXIMATE AND THEIR ACCURACY IS NOT GUARANTEED. THE CONTRACTOR SHALL VERIFY THE EXACT LOCATION AND ELEVATION OF ALL UTILITIES. THE CONTRACTOR SHALL REPORT ANY DISCREPANCIES TO THE ENGINEER AT ONCE. THE CONTRACTOR SHALL TAKE DUE CARE IN ALL PHASES OF THE CONSTRUCTION TO PROTECT ANY UTILITIES WHICH MAY BE AFFECTED BY THE WORK, INCLUDING MAKING ARRANGEMENTS FOR THE PROPER BRACING, AND OTHER REQUIRED PROTECTION, AS REQUIRED. ANY DAMAGE TO EXISTING UTILITIES SHALL BE REPAIRED AT THE CONTRACTOR'S EXPENSE.
4. FOR UNDERGROUND UTILITY LOCATIONS, CALL 48 HOURS BEFORE DIGGING, (EXCLUDING SATURDAY, SUNDAY & HOLIDAYS) J.U.L.I.E. 1-800-692-0123 OR 811.
5. TEMPORARY RAMPS SHALL BE PROVIDED AT ALL INTERSECTIONS DURING CONSTRUCTION AND PAID AS AGGREGATE FOR TEMPORARY ACCESS.
6. THE ENGINEER AND/OR ITS REPRESENTATIVE WILL BE PROVIDING CONSTRUCTION LAYOUT AND STAKING OF THE PROPOSED IMPROVEMENTS. IF CONTRACTOR'S OPERATIONS DAMAGE THE LAYOUT, THE VILLAGE MAY CHARGE A FEE, TO THE CONTRACTOR, TO COVER THE ADDITIONAL COSTS INCURRED BY THE VILLAGE FOR LAYOUT.
7. THE CONTRACTOR SHALL KEEP THE AREA OF CONSTRUCTION FREE OF DEBRIS AND OBJECTIONABLE MATERIALS DURING CONSTRUCTION OR THE VILLAGE RESERVES THE RIGHT TO REMOVE AND BACK CHARGE THE CONTRACTOR.
8. THE CONTRACTOR SHALL MAINTAIN ALL DRAINAGE FACILITIES DURING CONSTRUCTION AND SHALL REPAIR ANY DRAINAGE FACILITIES DAMAGED DURING CONSTRUCTION. THIS WORK SHALL BE CONSIDERED INCIDENTAL TO THE CONTRACT AND WILL NOT BE PAID FOR SEPARATELY.
9. ALL SIDEWALKS WITHIN THE PROJECT LIMITS THAT ARE ADJACENT TO THE CURB SHALL BE REMOVED AND REPLACED TO CONSTRUCT ADA RAMPS ACCORDING TO IDOT STANDARDS 424001, 424011, AND 424021. CATALOG CUTS OF DETECTABLE WARNINGS MUST BE APPROVED BY THE VILLAGE BEFORE INSTALLATION.
10. THE CONTRACTOR SHALL PROTECT ALL SIDEWALKS AND CURB & GUTTER FROM DAMAGE AND VANDALISM.
11. THE CONTRACTOR SHALL VERIFY THE ELEVATION AND LOCATION OF EXISTING SEWERS PRIOR TO THE START OF CONSTRUCTION OF NEW SEWERS.
12. ALL SAW CUTTING SHALL NOT BE PAID FOR SEPARATELY, BUT SHALL BE CONSIDERED INCLUDED IN THE PRICE OF THE APPLICABLE PAY ITEMS. SAW CUTTING SHALL BE PERFORMED AT LOCATIONS DESIGNATED ON THE PLANS OR AS DIRECTED BY THE ENGINEER.
13. PROOF ROLLS SHALL BE CONDUCTED ON ALL SUBGRADE AT INTERVALS NOT LESS THAN 100 FEET OR AS DIRECTED BY THE ENGINEER.
14. WHENEVER, DURING CONSTRUCTION OPERATIONS, ANY LOOSE MATERIAL IS DEPOSITED IN THE FLOW LINE OF DRAINAGE STRUCTURES, DITCHES, GUTTERS, ETC. SUCH THAT THE NATURAL FLOW OF WATER IS OBSTRUCTED, THE LOOSE MATERIAL WILL BE REMOVED AT THE CLOSE OF EACH WORKING DAY. AT THE CONCLUSION OF CONSTRUCTION OPERATIONS, ALL DRAINAGE STRUCTURES AND FLOW LINES SHALL BE FREE FROM DIRT AND DEBRIS. THIS WORK SHALL BE CONSIDERED INCLUDED IN THE COST OF THE CONTRACT.
15. ALL CURB SHALL BE DEPRESSED AT DRIVEWAYS.
16. ALL FULL REPLACEMENT DRIVEWAY APRONS ARE CONCRETE UNLESS OTHERWISE DIRECTED BY THE ENGINEER.
17. SUBGRADE SHALL BE PREPARED AS PER ARTICLE 301.03 OF THE STANDARD SPECIFICATIONS BEFORE REMOVAL OF ANY UNSUITABLE MATERIAL.
18. AGGREGATE SUBGRADE IMPROVEMENT HAS BEEN PROVIDED FOR SOILS WHICH TEND TO BE UNSTABLE WHEN WET. THE ACTUAL NEED FOR REMOVAL AND REPLACEMENT WILL BE DETERMINED IN THE FIELD AT THE TIME OF CONSTRUCTION BY THE ENGINEER (BY USE OF A CONE PENETROMETER IN CONJUNCTION WITH THE IDOT STABILITY MANUAL). NO ADDITIONAL COMPENSATION WILL BE DUE TO THE CONTRACTOR FOR ANY ADDITIONS TO OR DEDUCTIONS FROM THE CONTRACT AMOUNT. IF NO ADDITIONAL UNSUITABLE SOILS ARE ENCOUNTERED, THEN THE EXCESS QUANTITY SHALL BE DEDUCTED AND NO ADDITIONAL COMPENSATION WILL BE DUE TO THE CONTRACTOR.
20. AREAS OF REVERSE PITCH CURB AND GUTTER WILL BE MARKED IN THE FIELD BY THE ENGINEER DURING CONSTRUCTION.
21. ALL RADIUS DIMENSIONS ARE TO THE BACK OF CURB UNLESS OTHERWISE NOTED.
22. THE CONTRACTOR SHALL EXAMINE ALL PLANS AND SPECIFICATIONS, VISIT THE SITE OF THE WORK AND INFORM HIMSELF FULLY WITH THE WORK INVOLVED, GENERAL AND LOCAL CONDITIONS, ALL FEDERAL, STATE AND LOCAL LAWS, ORDINANCES, RULES AND REGULATIONS AND ALL OTHER PERTINENT ITEMS WHICH MAY AFFECT THE COST AND TIME OF COMPLETION OF THIS PROJECT BEFORE SUBMITTING A PROPOSAL.
23. PERMITS AND LICENSES OF A TEMPORARY NATURE NECESSARY FOR THE PROSECUTION OF THE WORK SHALL BE SECURED AND PAID FOR BY THE CONTRACTOR.
24. THE CONTRACTOR SHALL BE RESPONSIBLE FOR PROVIDING SAFE AND HEALTHFUL WORKING CONDITIONS THROUGHOUT THE CONSTRUCTION OF THE PROPOSED IMPROVEMENTS.
25. THIS PROJECT REQUIRES A US ARMY CORPS OF ENGINEERS (USACE) 404 PERMIT THAT WILL BE SECURED BY THE VILLAGE. AS A CONDITION OF THIS PERMIT, THE CONTRACTOR WILL NEED TO SUBMIT AN IN-STREAM WORK PLAN TO THE VILLAGE FOR ACCEPTANCE. GUIDELINES ON ACCEPTABLE IN-STREAM WORK TECHNIQUES CAN BE FOUND ON THE USACE WEBSITE. THE USACE DEFINES AND DETERMINES IN-STREAM WORK. THE COST OF ALL MATERIALS AND LABOR NECESSARY TO COMPLY WITH THE ABOVE PROVISIONS TO PREPARE AND IMPLEMENT AN IN-STREAM WORK PLAN WILL NOT BE PAID FOR SEPARATELY, BUT SHALL BE CONSIDERED AS INCLUDED IN THE UNIT BID PRICES OF THE CONTRACT AND NO ADDITIONAL COMPENSATION WILL BE ALLOWED.
26. SOIL DISTURBANCE SHALL BE IN SUCH A MANNER AS TO MINIMIZE EROSION. SOIL STABILIZATION MEASURES SHALL CONSIDER THE TIME OF YEAR, SITE CONDITIONS AND THE USE OF TEMPORARY OR PERMANENT MEASURES.
27. SOIL EROSION AND SEDIMENT CONTROL FEATURES SHALL BE CONSTRUCTED PRIOR TO THE COMMENCEMENT OF UPLAND DISTURBANCES.
28. ALL TEMPORARY AND PERMANENT EROSION CONTROL MEASURES MUST BE MAINTAINED AND REPAIRED AS NEEDED. THE GENERAL CONTRACTOR WILL BE RESPONSIBLE FOR INSPECTION AND REPAIR DURING CONSTRUCTION. THE OWNER WILL BE RESPONSIBLE IF EROSION CONTROL IS REQUIRED AFTER THE CONTRACTOR HAS COMPLETED THE CONTRACT.
29. THE EROSION CONTROL MEASURES INDICATED ON THE PLANS ARE THE MINIMUM REQUIREMENTS. ADDITIONAL MEASURES MAY BE REQUIRED AS DIRECTED BY THE ENGINEER OR GOVERNING AGENCY.
30. THE EROSION AND SEDIMENT CONTROLS, STORMWATER MANAGEMENT CONTROLS AND OTHER CONTROLS REQUIRED BY THE IN-STREAM WORK PLAN MUST BE AT LEAST AS PROTECTIVE AS THOSE SPECIFIED IN THE STANDARD SPECIFICATIONS FOR ROADWAY AND BRIDGE CONSTRUCTION OR THE ILLINOIS URBAN MANUAL.
31. THE NPDES/ESC DEFICIENCY DEDUCTION APPLIES TO THE IN-STREAM WORK PLAN
32. THE CONTRACTOR SHALL NOTIFY THE IDOT TRAFFIC CONTROL SUPERVISOR AT (847) 705-4470 A MINIMUM OF 72 HOURS IN ADVANCE OF BEGINNING WORK.
33. THE GENERAL CONTRACTOR IS REQUIRED TO HIRE AN ENVIRONMENTAL FIRM WITH AT LEAST FIVE (5) DOCUMENTED LEAKING UNDERGROUND STORAGE TANK CLEANUPS OR THAT IS PRE-QUALIFIED IN HAZARDOUS WASTE BY THE DEPARTMENT TO REMEDIATE THE SOIL CONTAMINATION AND MONITOR FOR WORKER PROTECTION.
34. PROTECTIVE COAT SHALL BE APPLIED TO ALL NEW CONCRETE GUTTER FLAGS, FACES, AND TOPS OF CURBS, SIDEWALKS, AND DRIVEWAY PAVEMENTS IN ACCORDANCE WITH THE REQUIREMENTS OF SECTION 1022 AND 1023 OF THE STANDARD SPECIFICATIONS, EXCEPT THAT IT SHALL BE APPLIED REGARDLESS OF THE TIME OF YEAR. THE PROTECTIVE COAT SHALL BE W.R. MEADOWS SEALTIGHT 1130 CLEAR, DAYTON SUPERIOR DAY-CHEM REZ CURE (J-11-W), OR APPROVED EQUIVALENT. THE CONTRACTOR SHALL ABIDE BY MANUFACTURER SPECIFICATIONS IN THE PREPARATION AND APPLICATION OF THE PROTECTIVE COAT. PROTECTIVE COAT WILL NOT BE PAID FOR SEPARATELY BUT SHALL BE INCLUDED IN THE COST OF THE APPLICABLE PAY ITEMS.
35. ACCESS TO ALL BUSINESSES MUST BE MAINTAINED AT ALL TIMES. DRIVEWAY CONSTRUCTION WORK SHALL BE STAGED TO ALLOW ACCESS. ENTRANCE SIGNS SHALL BE PLACED AT ALL DRIVEWAY ENTRANCES, AS SPECIFIED BY THE ENGINEER. DRIVEWAY ENTRANCE SIGNS SHALL BE IN ACCORDANCE WITH THE DRIVEWAY ENTRANCE SIGNAGE DETAIL AND AID FOR AS TEMPORARY INFORMATION SIGNAGE.
36. SIDEWALK REPLACEMENT THROUGH DRIVEWAYS SHALL BE CONSTRUCTED OF THE SAME THICKNESS AS THE ADJACENT DRIVEWAY, OR A MINIMUM OF 6 INCHES. THIS WORK SHALL BE PAID FOR AS PORTLAND CEMENT CONCRETE DRIVEWAY PAVEMENT, 6 INCH OR 8 INCH, SPECIAL.

000001-06	STANDARD SYMBOLS, ABBREVIATIONS AND PATTERNS
280001-07	TEMPORARY EROSION CONTROL SYSTEMS
420001-07	PAVEMENT JOINTS
424001-07	PERPENDICULAR CURB RAMPS FOR SIDEWALKS
424011-01	CORNER PARALLEL CURB RAMPS FOR SIDEWALKS
424021-01	DEPRESSED CORNER FOR SIDEWALKS
515001-03	NAME PLATE FOR BRIDGES
542301-03	PRECAST REINFORCED CONCRETE FLARED END SECTION
602301-03	INLET TYPE A
602401-03	MANHOLE TYPE A
602601-02	PRECAST REINFORCED FLAT SLAB TOP
602701-02	MANHOLE STEPS
604001-03	FRAME AND LIDS TYPE 1
604006-04	FRAME AND GRATE TYPE 3
604086-02	FRAME AND GRATE TYPE 23
608001-05	CONCRETE CURB TYPE B AND COMBINATION CONCRETE CURB AND GUTTER
635011-02	REFLECTOR MARKER AND MOUNTING DETAILS
643001-01	SAND MODULE IMPACT ATTENUATORS
701006-04	OFF-RD OPERATIONS, 2L, 2W, 15' (4.5 M) TO 24' (600 MM) FROM PAVEMENT
701011-03	OFF-RD MOVING OPERATIONS, 2L, 2W, DAY ONLY
701301-04	LANE CLOSURE, 2L, 2W, SHORT TIME OPERATIONS
701311-03	LANE CLOSURE, 2L, 2W MOVING OPERATIONS-DAY ONLY
701501-06	URBAN LANE CLOSURE, 2L, 2W, UNDIVIDED
701502-05	URBAN LANE CLOSURE, 2L, 2W, WITH BIDIRECTIONAL LEFT TURN LANE
701701-08	URBAN LANE CLOSURE, MULTILANE INTERSECTION
701801-05	SIDEWALK CORNER OR CROSSWALK CLOSURE
701901-02	TRAFFIC CONTROL DEVICES
704001-07	TEMPORARY CONCRETE BARRIER
720001-01	SIGN PANEL MOUNTING DETAILS
720006-03	SIGN PANEL ERECTION DETAILS
720011-01	METAL POSTS FOR SIGNS, MARKERS AND DELINEATORS
729001-01	APPLICATIONS OF TYPES OF A & B METAL POSTS (FOR SIGNS & MARKERS)
782001	PRISMATIC CURB REFLECTORS
857001-01	STANDARD PHASE DESIGNATION DIAGRAMS AND PHASE SEQUENCES
873001-02	TRAFFIC SIGNAL GROUNDING AND BONDING
880006-01	TRAFFIC SIGNAL MOUNTING DETAILS

IDOT DISTRICT ONE STANDARD DRAWINGS

BD-7	DETAIL OF STORM SEWER CONNECTION TO EXISTING SEWER
BD-22	PAVEMENT PATCHING FOR HMA SURFACED PAVEMENT
BD-32	BUTT JOINT AND HMA TAPER DETAILS
TC-10	TRAFFIC CONTROL & PROTECTION FOR SIDE ROADS, INTERSECTIONS, & DRIVEWAYS
TC-13	TYPICAL PAVEMENT MARKINGS
TC-14	TRAFFIC CONTROL & PROTECTION AT TURN BAYS (TO REMAIN OPEN TO TRAFFIC)
TC-16	PAVEMENT MARKING LETTERS AND SYMBOLS FOR TRAFFIC STAGING
TC-21	DETOUR SIGNING FOR CLOSING STATE HIGHWAYS
TC-26	DRIVEWAY ENTRANCE SIGNING
TS-05	STANDARD TRAFFIC SIGNAL DESIGN DETAILS
TS-09	PEDESTRIAN PUSH-BUTTON POST, TYPE A

FILE NAME - DETAILS.DWG	DESIGNED -- DRAWN -- CHECKED -- DATE --	REVISED -- REVISED -- REVISED -- REVISED --	STATE OF ILLINOIS DEPARTMENT OF TRANSPORTATION	Hassell Road STP Project General Notes and Legend	F.A.U. RTE. 1100	SECTION 11-00087-00-PP	COUNTY Cook	TOTAL SHEETS 164 SHEET NO. 2	CONTRACT NO. 63770
				SCALE: NONE	SHEET NO. 1 OF 2 SHEETS	STA.	TO STA.	ILLINOIS FED. AID PROJECT CMM 9003(757)	

LEGEND

EXISTING	PROPOSED				
		SANITARY MANHOLE	RCN	STRUCTURES TO BE RECONSTRUCTED	
		STORM MANHOLE	ADJ	STRUCTURES TO BE ADJUSTED	
		STORM INLET	F&G	NEW FRAME AND GRATE	
		VALVE & VAULT	F&L	NEW FRAME AND LID	
		FIRE HYDRANT	C	EXISTING CONCRETE APRON	
		STREET LIGHT	C/A	EXISTING CONCRETE & ASPHALT APRON	
		STREET SIGN	A	EXISTING ASPHALT APRON	
		STORM SEWER			
		SANITARY SEWER		PROPOSED SIDEWALK	
		WATER MAIN		REMOVAL OF SIDEWALK	
		MAIL BOX		CONSTRUCTION STAGING WORK AREA	
		POWER POLE		SEGMENTAL BLOCK RETAINING WALL	
		DETECTABLE WARNINGS		SEEDING, CLASS 2A	
		STREET LIGHT CABLE		TEMPORARY CONCRETE BARRIER	
		STREET LIGHT CABLE CROSSING		TREE REMOVAL, DIAMETER SHOWN	
		NICOR GAS VALVE		SIGN TO BE RELOCATED	
		AT&T HANDHOLE		STORM SEWER TO BE REMOVED	
		AT&T BURIED UTILITY			
		COMCAST BURIED UTILITY			
		COMED BURIED UTILITY			
		NICOR BURIED UTILITY			
		FIBER OPTIC CABLE			
		HANDRAIL			
		TREES			
		INLET FILTER			
		SILT FILTER FENCE			
		TEMPORARY FENCE			
		PUBLIC EASEMENT			

BENCHMARK TABLE		
BENCHMARK NO.	DESCRIPTION	ELEVATION*
BM 2	SOUTH-SOUTHEAST UPPER FLANGE BOLT ON FIRE HYDRANT AT HASSELL ROAD STA 10+15R	821.70
BM 3	SOUTH-SOUTHWEST UPPER FLANGE BOLT ON FIRE HYDRANT AT HASSELL ROAD STA 14+05L AND PEMBROKE AVENUE INTERSECTION	805.47
BM 4	NORTH-NORTHEAST UPPER FLANGE BOLT ON FIRE HYDRANT AT HASSELL ROAD STA 16+80R	801.58
BM 5	SOUTHEAST UPPER FLANGE BOLT ON FIRE HYDRANT AT HASSELL ROAD STA 19+17L AND STONINGTON AVENUE INTERSECTION	796.56
BM 6	NORTH-NORTHEAST UPPER FLANGE BOLT ON FIRE HYDRANT AT HASSELL ROAD STA 22+26R	792.24
BM 7	NORTH "X" ON CONCRETE LIGHT POLE AT HASSELL ROAD STA 26+71R	790.75
BM 8	SOUTH "X" ON SANITARY MANHOLE AT HASSELL ROAD STA 31+61L	792.50
BM 9	SOUTH "X" ON CONCRETE LIGHT POLE AT HASSELL ROAD STA 35+24L	798.63
BM 10	NORTH-NORTHEAST UPPER FLANGE BOLT ON FIRE HYDRANT AT HASSELL ROAD STA 40+92R AND HOLBROOK LANE INTERSECTION	808.62
BM 11	NORTH-NORTHEAST UPPER FLANGE BOLT ON FIRE HYDRANT AT HASSELL ROAD STA 46+10R AND BRIGHTON LANE INTERSECTION	805.95
BM 12	NORTH-NORTHEAST UPPER FLANGE BOLT ON FIRE HYDRANT AT HASSELL ROAD STA 48+68R AND OXFORD LANE INTERSECTION	805.44
BM 13	NORTH "X" ON SANITARY MANHOLE RIM IN PAVEMENT OF ERIE LANE AT HASSELL ROAD STA 52+70R	808.11
BM 14	SOUTH-SOUTHWEST UPPER FLANGE BOLT ON FIRE HYDRANT AT HASSELL ROAD STA 56+60R	805.36
BM 15	SOUTH "X" ON SANITARY MANHOLE RIM AT HASSELL ROAD STA 62+35L	794.51
BM 16	NORTH-NORTHEAST UPPER FLANGE BOLT ON FIRE HYDRANT AT HASSELL ROAD STA 69+06R	795.82
BM 17	SOUTH-SOUTHWEST UPPER FLANGE BOLT ON FIRE HYDRANT AT HASSELL ROAD STA 75+94L AND PARKVIEW CIRCLE EAST INTERSECTION	796.43
BM 18	SOUTH-SOUTHWEST UPPER FLANGE BOLT ON FIRE HYDRANT AT HASSELL ROAD STA 80+75L	796.68
BM 19	NORTH-NORTHWEST UPPER FLANGE BOLT ON FIRE HYDRANT AT HASSELL ROAD STA 85+33L	801.10

* NGVD 29 DATUM

SUMMARY OF QUANTITIES

PAY ITEM #	ITEM DESCRIPTION	UNIT	TOTAL QUANTITY	CONSTRUCTION TYPE CODE					
				0004	0011	0021	0031	0042	
20100110	TREE REMOVAL (6 TO 15 UNITS DIAMETER)	UNIT	381					381	
20100210	TREE REMOVAL (OVER 15 UNITS DIAMETER)	UNIT	311					311	
20101000	TEMPORARY FENCE	FOOT	160		160				
20200100	EARTH EXCAVATION	CU YD	13,707	13,707					
20200500	EARTH EXCAVATION (WIDENING)	CU YD	33	33					
20201200	REMOVAL AND DISPOSAL OF UNSUITABLE MATERIAL	CU YD	5,562	4,903	659				
20800150	TRENCH BACKFILL	CU YD	666	666					
20900110	POROUS GRANULAR BACKFILL	CU YD	830		830				
21001000	GEOTECHNICAL FABRIC FOR GROUND STABILIZATION	SQ YD	40,738	40,738					
* 21101625	TOPSOIL FURNISH AND PLACE, 6"	SQ YD	17,400					17,400	
21400100	GRADING AND SHAPING DITCHES	FOOT	400	400					
* 25000210	SEEDING, CLASS 2A	ACRE	0.2					0.2	
* 25000400	NITROGEN FERTILIZER NUTRIENT	POUND	215					215	
* 25000500	PHOSPHORUS FERTILIZER NUTRIENT	POUND	215					215	
* 25000600	POTASSIUM FERTILIZER NUTRIENT	POUND	215					215	
* 25100630	EROSION CONTROL BLANKET	SQ YD	1,005	1,005					
* 25200100	SODDING	SQ YD	16,251					16,251	
* 25200200	SUPPLEMENTAL WATERING	UNIT	53					53	
28000400	PERIMETER EROSION BARRIER	FOOT	2,635	2,635					
28000510	INLET FILTERS	EACH	139						
30300001	AGGREGATE SUBGRADE IMPROVEMENT	CU YD	5,562	5,562					
30300106	AGGREGATE SUBGRADE IMPROVEMENT 6"	SQ YD	39,865	39,865					
30300108	AGGREGATE SUBGRADE IMPROVEMENT 8"	SQ YD	873	873					
35101600	AGGREGATE BASE COURSE, TYPE B 4"	SQ YD	3,473	3,473					
35101800	AGGREGATE BASE COURSE, TYPE B 6"	SQ YD	1,587	1,587					
35102200	AGGREGATE BASE COURSE, TYPE B 10"	SQ YD	755	755					
35102400	AGGREGATE BASE COURSE, TYPE B 12"	SQ YD	51	51					
40201000	AGGREGATE FOR TEMPORARY ACCESS	TON	1,570	1,570					
40600100	BITUMINOUS MATERIALS (PRIME COAT)	GALLON	4,042	4,042					
40600300	AGGREGATE (PRIME COAT)	TON	81	81					

PAY ITEM #	ITEM DESCRIPTION	UNIT	TOTAL QUANTITY	CONSTRUCTION TYPE CODE					
				0004	0011	0021	0031	0042	
40600635	LEVELING BINDER (MACHINE METHOD), N70	TON	41	41					
40600982	HOT-MIX ASPHALT SURFACE REMOVAL -- BUTT JOINT	SQ YD	87	87					
40603340	HOT-MIX ASPHALT SURFACE COURSE, MIX "D", N70	TON	109	109					
40701801	HOT-MIX ASPHALT PAVEMENT (FULL-DEPTH), 6"	SQ YD	623	623					
40701841	HOT-MIX ASPHALT PAVEMENT (FULL-DEPTH), 8"	SQ YD	470	470					
40701881	HOT-MIX ASPHALT PAVEMENT (FULL-DEPTH), 10"	SQ YD	36,676	36,676					
42000100	PORTLAND CEMENT CONCRETE PAVEMENT 6"	SQ YD	15		15				
42000516	PORTLAND CEMENT CONCRETE PAVEMENT 10 3/4" (JOINTED)	SQ YD	51	51					
42400200	PORTLAND CEMENT CONCRETE SIDEWALK 5 INCH	SQ FT	28,044					28,044	
42400800	DETECTABLE WARNINGS	SQ FT	1,154					1,154	
44000100	PAVEMENT REMOVAL	SQ YD	36,634	36,634					
44000160	HOT-MIX ASPHALT SURFACE REMOVAL, 2 3/4"	SQ YD	949	949					
44000200	DRIVEWAY PAVEMENT REMOVAL	SQ YD	2,820	2,820					
44000500	COMBINATION CURB AND GUTTER REMOVAL	FOOT	16,381	16,381					
44000600	SIDEWALK REMOVAL	SQ FT	25,343					25,343	
44201741	CLASS D PATCHES, TYPE II, 8 INCH	SQ YD	30	30					
44201745	CLASS D PATCHES, TYPE III, 8 INCH	SQ YD	20	20					
44201747	CLASS D PATCHES, TYPE IV, 8 INCH	SQ YD	72	72					
50102400	CONCRETE REMOVAL	CU YD	115		115				
50104000	BRIDGE RAIL REMOVAL	FOOT	276		276				
50105220	PIPE CULVERT REMOVAL	FOOT	274		274				
50800105	REINFORCEMENT BARS	POUND	11,370		11,370				
50800205	REINFORCEMENT BARS, EPOXY COATED	POUND	24,920		24,920				
* 50901760	PIPE HANDRAIL	FOOT	90					90	
51500100	NAME PLATES	EACH	3		3				
54001001	BOX CULVERT END SECTIONS, CULVERT NO. 1	EACH	2		2				
54001002	BOX CULVERT END SECTIONS, CULVERT NO. 2	EACH	2		2				
54002020	EXPANSION BOLTS 3/4 INCH	EACH	82		82				
54003000	CONCRETE BOX CULVERTS	CU YD	123		123				
54011006	PRECAST CONCRETE BOX CULVERTS 10' X 6'	FOOT	257		257				

* = SPECIALTY ITEM

PLAN
 SURVEY
 CHECKED
 DATE
 NO.

PROFILE
 SURVEY
 CHECKED
 DATE
 NO.

FILE NAME -
 Summary of Quantities.dwg

DESIGNED -
 DRAWN -
 CHECKED -
 DATE -

REVISED -
 REVISED -
 REVISED -
 REVISED -

STATE OF ILLINOIS
 DEPARTMENT OF TRANSPORTATION

Hassell Road STP Project
 Summary of Quantities

SCALE: NTS SHEET NO. 1 OF 4 SHEETS STA. TO STA.

F.A.U. RTE.	SECTION	COUNTY	TOTAL SHEETS	SHEET NO.
1100	11-00087-00-FP	Cook	164	4
CONTRACT NO. 63770			ILLINOIS FED. AID PROJECT CMM 9003(757)	

SUMMARY OF QUANTITIES

PAY ITEM #	ITEM DESCRIPTION	UNIT	TOTAL QUANTITY	CONSTRUCTION TYPE CODE					
				0004	0011	0021	0031	0042	
54213657	PRECAST REINFORCED CONCRETE FLARED END SECTIONS 12"	EACH	5	5					
54248510	CONCRETE COLLAR	CU YD	2		2				
550A0330	STORM SEWERS, CLASS A, TYPE 2 10"	FOOT	8	8					
550A0400	STORM SEWERS, CLASS A, TYPE 2 21"	FOOT	22		22				
550A0410	STORM SEWERS, CLASS A, TYPE 2 24"	FOOT	6		6				
550B0330	STORM SEWERS, CLASS B, TYPE 2 10"	FOOT	11		11				
550A2520	STORM SEWERS, RUBBER GASKET, CLASS A, TYPE 2 12"	FOOT	1,124	1,124					
550A2530	STORM SEWERS, RUBBER GASKET, CLASS A, TYPE 2 15"	FOOT	91	91					
550A2540	STORM SEWERS, RUBBER GASKET, CLASS A, TYPE 2 18"	FOOT	67	67					
55100300	STORM SEWER REMOVAL 8"	FOOT	124	124					
55100400	STORM SEWER REMOVAL 10"	FOOT	712	706	6				
55100500	STORM SEWER REMOVAL 12"	FOOT	653	653					
55100700	STORM SEWER REMOVAL 15"	FOOT	127	127					
55100900	STORM SEWER REMOVAL 18"	FOOT	82	82					
55101100	STORM SEWER REMOVAL 21"	FOOT	20		20				
55101200	STORM SEWER REMOVAL 24"	FOOT	19	15	4				
56106500	ADJUSTING WATER MAIN 10"	FOOT	73		73				
60107700	PIPE UNDERDRAINS 6"	FOOT	20	20					
60108100	PIPE UNDERDRAINS 4" (SPECIAL)	FOOT	740	740					
60218500	MANHOLES, TYPE A, 4"-DIAMETER, TYPE 3 FRAME AND GRATE	EACH	14	14					
60234200	INLETS, TYPE A, TYPE 1 FRAME, OPEN LID	EACH	2	2					
60235700	INLETS, TYPE A, TYPE 3 FRAME AND GRATE	EACH	44	44					
60238800	INLETS, TYPE A	EACH	1	1					
60255500	MANHOLES TO BE ADJUSTED	EACH	19	19					
60256930	MANHOLES TO BE ADJUSTED WITH NEW TYPE 23 FRAME AND GRATE	EACH	1	1					
60265700	VALVE VAULTS TO BE ADJUSTED	EACH	14	14					
60406100	FRAMES AND LIDS, TYPE 1, CLOSED LID	EACH	5	5					
60500040	REMOVING MANHOLES	EACH	26	26					
60500060	REMOVING INLETS	EACH	36	36					
60605000	COMBINATION CONCRETE CURB AND GUTTER, TYPE B-6.24	FOOT	100	100					

* = SPECIALTY ITEM

PAY ITEM #	ITEM DESCRIPTION	UNIT	TOTAL QUANTITY	CONSTRUCTION TYPE CODE					
				0004	0011	0021	0031	0042	
60605100	COMBINATION CONCRETE CURB AND GUTTER, TYPE B-6.24 (ABUTTING EXISTING PAVEMENT)	FOOT	150	150					
* 66900200	NON-SPECIAL WASTE DISPOSAL	CU YD	1,848	1,848					
* 66900450	SPECIAL WASTE PLANS AND REPORTS	L SUM	1	1					
* 66900530	SOIL DISPOSAL ANALYSIS	EACH	1	1					
67100100	MOBILIZATION	L SUM	1	1					
70300210	TEMPORARY PAVEMENT MARKING LETTERS AND SYMBOLS	SQ FT	127				127		
70300220	TEMPORARY PAVEMENT MARKING - LINE 4"	FOOT	5,000					5,000	
* 70300510	PAVEMENT MARKING TAPE, TYPE III - LETTERS AND SYMBOLS	SQ FT	63					63	
* 70300520	PAVEMENT MARKING TAPE, TYPE III 4"	FOOT	31,665					31,665	
* 70300540	PAVEMENT MARKING TAPE, TYPE III 6"	FOOT	155					155	
* 70300560	PAVEMENT MARKING TAPE, TYPE III 12"	FOOT	280					280	
* 70300570	PAVEMENT MARKING TAPE, TYPE III 24"	FOOT	45					45	
70301000	WORK ZONE PAVEMENT MARKING REMOVAL	SQ FT	8,079					8,079	
70400100	TEMPORARY CONCRETE BARRIER	FOOT	112					112	
70400200	RELOCATE TEMPORARY CONCRETE BARRIER	FOOT	100					100	
* 70600255	IMPACT ATTENUATORS, TEMPORARY (FULLY REDIRECTIVE, NARROW), TEST LEVEL 2	EACH	2					2	
* 70600322	IMPACT ATTENUATORS, RELOCATE (FULLY REDIRECTIVE, NARROW), TEST LEVEL 2	EACH	2					2	
* 72000100	SIGN PANEL - TYPE 1	SQ FT	214					214	
* 72400100	REMOVE SIGN PANEL ASSEMBLY - TYPE A	EACH	226					226	
* 72400500	RELOCATE SIGN PANEL ASSEMBLY - TYPE A	EACH	217					217	
* 72900100	METAL POST - TYPE A	FOOT	29					29	
* 78000100	THERMOPLASTIC PAVEMENT MARKING - LETTERS AND SYMBOLS	SQ FT	884					884	
* 78000200	THERMOPLASTIC PAVEMENT MARKING - LINE 4"	FOOT	19,146					19,146	
* 78000400	THERMOPLASTIC PAVEMENT MARKING - LINE 6"	FOOT	6,603					6,603	
* 78000600	THERMOPLASTIC PAVEMENT MARKING - LINE 12"	FOOT	115					115	
* 78000650	THERMOPLASTIC PAVEMENT MARKING - LINE 24"	FOOT	833					833	
* 78001100	PAINT PAVEMENT MARKING - LETTERS AND SYMBOLS	SQ FT	146					146	
* 78001110	PAINT PAVEMENT MARKING - LINE 4"	FOOT	420					420	
* 78001130	PAINT PAVEMENT MARKING - LINE 6"	FOOT	1,320					1,320	
* 78001180	PAINT PAVEMENT MARKING - LINE 24"	FOOT	115					115	

PLAN SHEET NO. 1100
 DATE: 11-00087-00-FP
 SECTION: 11-00087-00-FP
 COUNTY: Cook
 TOTAL SHEETS: 164
 SHEET NO.: 5

PROFILE SHEET NO. 1100
 DATE: 11-00087-00-FP
 SECTION: 11-00087-00-FP
 COUNTY: Cook
 TOTAL SHEETS: 164
 SHEET NO.: 5

FILE NAME - Summary of Quantities.dwg
 DESIGNED -
 DRAWN -
 CHECKED -
 DATE -

REVISED -
 REVISED -
 REVISED -
 REVISED -

DESIGNED -
 DRAWN -
 CHECKED -
 DATE -

REVISED -
 REVISED -
 REVISED -
 REVISED -

STATE OF ILLINOIS
 DEPARTMENT OF TRANSPORTATION

Hassell Road STP Project
 Summary of Quantities

SCALE: NTS SHEET NO. 2 OF 4 SHEETS STA. TO STA.

F.A.U. R.T.E. 1100
 SECTION 11-00087-00-FP
 COUNTY Cook
 TOTAL SHEETS 164
 SHEET NO. 5
 CONTRACT NO. 63770
 ILLINOIS FED. AID PROJECT CMM 9003(757)

SUMMARY OF QUANTITIES

PAY ITEM #	ITEM DESCRIPTION	UNIT	TOTAL QUANTITY	CONSTRUCTION TYPE CODE					
				0004	0011	0021	0031	0042	
* 78006100	PREFORMED THERMOPLASTIC PAVEMENT MARKING - LETTERS AND SYMBOLS	SQ FT	692			692			
* 78200300	PRISMATIC CURB REFLECTOR	EACH	16			16			
* 78200530	BARRIER WALL MARKERS, TYPE C	EACH	5			5			
78300100	PAVEMENT MARKING REMOVAL	SQ FT	4,473			4,473			
* 81028200	UNDERGROUND CONDUIT, GALVANIZED STEEL, 2" DIA.	FOOT	87			87			
* 81028240	UNDERGROUND CONDUIT, GALVANIZED STEEL, 4" DIA.	FOOT	92			92			
* 85000300	MAINTENANCE OF EXISTING TRAFFIC SIGNAL INSTALLATION	L SUM	1			1			
* 87301215	ELECTRIC CABLE IN CONDUIT, SIGNAL NO. 14 2C	FOOT	1,396			1,396			
* 87301225	ELECTRIC CABLE IN CONDUIT, SIGNAL NO. 14 3C	FOOT	1,465			1,465			
* 87301900	ELECTRIC CABLE IN CONDUIT, EQUIPMENT GROUNDING CONDUCTOR, NO. 6 1C	FOOT	120			120			
* 87502440	TRAFFIC SIGNAL POST, GALVANIZED STEEL 10 FT.	EACH	4			4			
* 87800100	CONCRETE FOUNDATION, TYPE A	FOOT	20			20			
* 87900200	DRILL EXISTING HANDHOLE	EACH	7			7			
* 88102717	PEDESTRIAN SIGNAL HEAD, LED, 1-FACE, BRACKET MOUNTED WITH COUNTDOWN TIMER	EACH	6			6			
* 88102747	PEDESTRIAN SIGNAL HEAD, LED, 2-FACE, BRACKET MOUNTED WITH COUNTDOWN TIMER	EACH	1			1			
* 88800100	PEDESTRIAN PUSH-BUTTON	EACH	8			8			
* 89502375	REMOVE EXISTING TRAFFIC SIGNAL EQUIPMENT	EACH	1			1			
* A2000086	TREE, ACER X FREEMANI ARMSTRONG (ARMSTRONG FREEMAN MAPLE), 2-1/2" CALIPER, BALLED AND BURLAPPED	EACH	8					8	
* A2000320	TREE, ACER MIYABEI MORTON (STATE STREET MIYABE MAPLE), 2-1/2" CALIPER, BALLED AND BURLAPPED	EACH	10					10	
* A2002502	TREE, CARPINUS BETULUS FASTIGIATA (COLUMNAR EUROPEAN HORNBEAM), 3" CALIPER, BALLED AND BURLAPPED	EACH	5					5	
* A2005020	TREE, GYMNOCLADUS DIOICUS (KENTUCKY COFFEETREE), 2-1/2" CALIPER, BALLED AND BURLAPPED	EACH	5					5	
* A2005420	TREE, LIRIODENDRON TULIPIFERA (TULIP TREE), 2-1/2" CALIPER, BALLED AND BURLAPPED	EACH	7					7	
* A2005620	TREE, OSTRYA VIRGINIANA (AMERICAN HOPHORNBEAM), 2-1/2" CALIPER, BALLED AND BURLAPPED	EACH	12					12	
* A2007920	TREE, TILIA AMERICANA REDMOND (REDMOND AMERICAN LINDEN), 2-1/2" CALIPER, BALLED AND BURLAPPED	EACH	9					9	
* B2000566	TREE, AMELANCHIER CANADENSIS (SHADBLOW SERVICEBERRY), 6' HEIGHT, SHRUB FORM, BALLED AND BURLAPPED	EACH	12					12	
* B2001166	TREE, CERCIS CANADENSIS (EASTERN REDBUD), 6' HEIGHT, CLUMP FORM, BALLED AND BURLAPPED	EACH	11					11	
* B2001666	TREE, CRATAEGUS CRUSGALU INERMIS (THORNLESS COCKSPUR HAWTHORN), 6' HEIGHT, SHRUB FORM, BALLED AND BURLAPPED	EACH	11					11	
* B2002466	TREE, MAGNOLIA SOULANGIANA (SAUCER MAGNOLIA), 6' HEIGHT, CLUMP FORM, BALLED AND BURLAPPED	EACH	13					13	
* B2006220	TREE, SYRINGA RETICULATA (JAPANESE TREE LILAC), 2-1/2" CALIPER, TREE FORM, BALLED AND BURLAPPED	EACH	9					9	
* X0323444	DECORATIVE STEEL RAILING	FOOT	303		303				

* = SPECIALTY ITEM

PAY ITEM #	ITEM DESCRIPTION	UNIT	TOTAL QUANTITY	CONSTRUCTION TYPE CODE					
				0004	0011	0021	0031	0042	
X4230710	PORTLAND CEMENT CONCRETE DRIVEWAY PAVEMENT, 6 INCH, SPECIAL	SQ YD	357	357					
X4230800	PORTLAND CEMENT CONCRETE DRIVEWAY PAVEMENT, 8 INCH, SPECIAL	SQ YD	1,572	1,572					
X5504200	DUCTILE IRON STORM SEWER, 12 INCH	FOOT	84	84					
X6064200	COMBINATION CONCRETE CURB AND GUTTER, TYPE B-6.12 (SPECIAL)	FOOT	16,317	16,317					
X7010216	TRAFFIC CONTROL AND PROTECTION, (SPECIAL)	L SUM	1					1	
* X8760055	PEDESTRIAN PUSH-BUTTON POST, TYPE A	EACH	1					1	
XX008003	FORM LINER TEXTURED SURFACE, SPECIAL	SQ FT	982	982					
Z0004518	HOT-MIX ASPHALT DRIVEWAY PAVEMENT, 5"	SQ YD	755	755					
Z0030850	TEMPORARY INFORMATION SIGNING	SQ FT	288					288	
* Z0064560	SEGMENTAL BLOCK RETAINING WALL	SQ FT	180					180	
Z0073002	TEMPORARY SOIL RETENTION SYSTEM	SQ FT	1,277	1,277					
Z0076600	TRAINEES	HOURL	1,000					1,000	
Z0076604	TRAINEES TRAINING PROGRAM GRADUATE	HOURL	1,000					1,000	
XX008744	STORM SEWERS, CLASS B, TYPE 2 8"	FOOT	124	124					

PLAN SURVEYED
 PLOTTED
 ALIGNED CHECKED
 NOTE BOOK NO.
 PROFILE NAME

PROFILE SURVEYED
 PLOTTED
 REVISIONS
 NOTE BOOK NO.
 STRUCTURE NOTATION CHRG

FILE NAME -
 Summary of Quantities.dwg

DESIGNED -
 DRAWN -
 CHECKED -
 DATE -

REVISED -
 REVISED -
 REVISED -
 REVISED -

STATE OF ILLINOIS
 DEPARTMENT OF TRANSPORTATION

Hassell Road STP Project
 Summary of Quantities
 SCALE: NTS SHEET NO. 3 OF 4 SHEETS STA. TO STA.

F.A.U. R.T.E. 1100 SECTION 11-00087-00-FP COUNTY Cook TOTAL SHEETS 164 SHEET NO. 6 CONTRACT NO. 63770 ILLINOIS FED. AID PROJECT CMM 9603(757)

EARTHWORK SCHEDULE

	EARTH EXCAVATION (CY)				REMOVAL AND DISPOSAL OF UNSUITABLE MATERIAL (CY)				NON-SPECIAL WASTE DISPOSAL (CY)				TOTAL SUITABLE EXCAVATION (CY)				EXCAVATION TO BE USED IN EMBANKMENT (ADJ FOR 15% SHRINKAGE FACTOR) (CY)				EMBANKMENT (CY)				EARTHWORK BALANCE WASTE (+) OR SHORTAGE (-) (CY)			
	STAGE 1	STAGE 2	STAGE 3	STAGE 4	STAGE 1	STAGE 2	STAGE 3	STAGE 4	STAGE 1	STAGE 2	STAGE 3	STAGE 4	STAGE 1	STAGE 2	STAGE 3	STAGE 4	STAGE 1	STAGE 2	STAGE 3	STAGE 4	STAGE 1	STAGE 2	STAGE 3	STAGE 4	STAGE 1	STAGE 2	STAGE 3	STAGE 4
HASSELL ROAD	4,796	4,552	2,029	1,196	1,548	1,548	762	1,704	704	602	541	0	4,092	3,950	1,488	1,196	3,478	3,357	1,264	1,017	145	230	327	418	3,333	3,128	937	598
PEMBROKE AVENUE	29	0	0	0	0	0	0	0	0	0	0	0	29	0	0	0	25	0	0	0	0	0	0	0	25	0	0	0
STONINGTON AVENUE	37	0	0	0	0	0	0	0	0	0	0	0	37	0	0	0	31	0	0	0	0	0	0	0	31	0	0	0
BLACKBERRY LANE	0	36	0	0	0	0	0	0	0	0	0	0	0	36	0	0	0	31	0	0	0	0	0	0	0	31	0	0
HOLBROOK LANE	0	18	0	0	0	0	0	0	0	0	0	0	0	18	0	0	0	15	0	0	0	0	0	0	0	15	0	0
CARDIGAN PLACE	0	40	0	0	0	0	0	0	0	0	0	0	0	40	0	0	0	34	0	0	0	0	0	0	0	34	0	0
BRIGHTON LANE	0	27	0	0	0	0	0	0	0	0	0	0	0	27	0	0	0	23	0	0	0	0	0	0	0	23	0	0
OXFORD LANE	0	32	0	0	0	0	0	0	0	0	0	0	0	32	0	0	0	27	0	0	0	0	0	0	0	27	0	0
GEORGETOWN LANE	0	44	0	0	0	0	0	0	0	0	0	0	0	44	0	0	0	37	0	0	0	0	0	0	0	37	0	0
ERIE LANE	0	31	0	0	0	0	0	0	0	0	0	0	0	31	0	0	0	26	0	0	0	0	0	0	0	26	0	0
KENSINGTON LANE	0	45	0	0	0	0	0	0	0	0	0	0	0	45	0	0	0	38	0	0	0	0	0	0	0	38	0	0
PARKVIEW CIRCLE (W)	0	0	23	0	0	0	0	0	0	0	0	0	0	0	23	0	0	20	0	0	0	0	0	0	0	0	20	0
PARKVIEW CIRCLE (E)	0	0	0	35	0	0	0	0	0	0	0	0	0	0	0	35	0	0	0	30	0	0	0	0	0	0	0	30
ROSEDALE LANE	0	0	0	43	0	0	0	0	0	0	0	0	0	0	0	43	0	0	0	37	0	0	0	0	0	0	0	37
DRIVEWAYS	498	151	0	45	0	0	0	0	0	0	0	0	498	151	0	45	423	128	0	38	0	0	0	0	423	128	0	38
TOTAL	5,360	4,976	2,052	1,319	1,548	1,548	762	1,704	704	602	541	0	4,656	4,374	1,511	1,319	3,958	3,718	1,284	1,121	145	230	327	418	3,813	3,488	937	703

	STAGE 1	STAGE 2	STAGE 3	STAGE 4	TOTAL
EARTH EXCAVATION	5,360	4,976	2,052	1,319	13,707
REMOVAL AND DISPOSAL OF UNSUITABLE MATERIAL	1,548	1,548	762	1,704	5,562
NON-SPECIAL WASTE DISPOSAL	704	602	541	0	1,848

A 15% SHRINKAGE FACTOR SHALL BE USED FOR THIS CONTRACT.

NON-SPECIAL WASTE DISPOSAL SHALL INCLUDE THE TRANSPORTATION AND DISPOSAL. THE EXCAVATION OF THE MATERIAL SHALL ALSO BE PAID FOR AS EARTH EXCAVATION.

ALL AREAS OF UNDERCUT SHALL BE PAID FOR AS REMOVAL AND DISPOSAL OF UNSUITABLE MATERIALS ONLY. ANY UNDERCUT AREAS THAT REQUIRE NON-SPECIAL WASTE DISPOSAL WILL NOT BE PAID FOR AS NON-SPECIAL WASTE DISPOSAL.

PLAN SURVEYED BY: DATE: CHECKED BY: DATE: NOTE BOOK NO. OF WAY CHECKED: DATE: NAME:

PROFILE SURVEYED BY: DATE: CHECKED BY: DATE: NOTE BOOK NO. OF WAY CHECKED: DATE: NAME: STRUCTURE NO. OF WAY CHECKED: DATE: NAME:

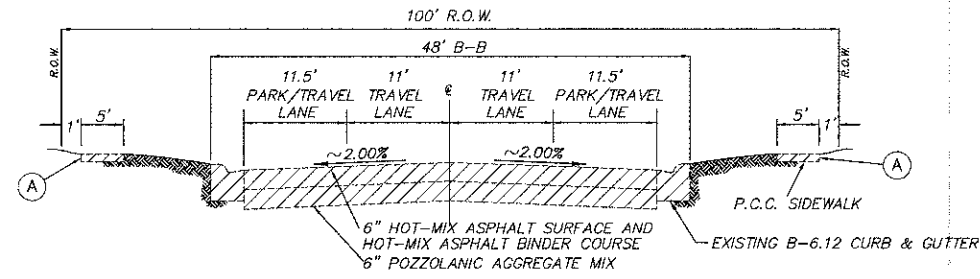

EXISTING PAVEMENT TYPICAL SECTION

STA 12+72 TO 23+50

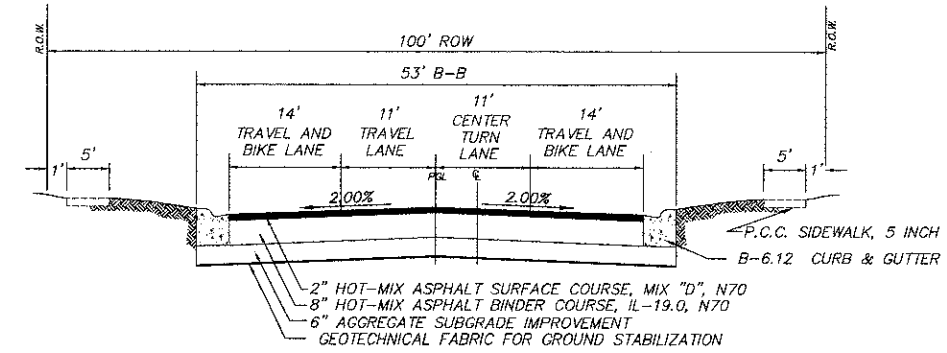

PROPOSED RECONSTRUCTION TYPICAL SECTION

STA 12+72 TO 26+00

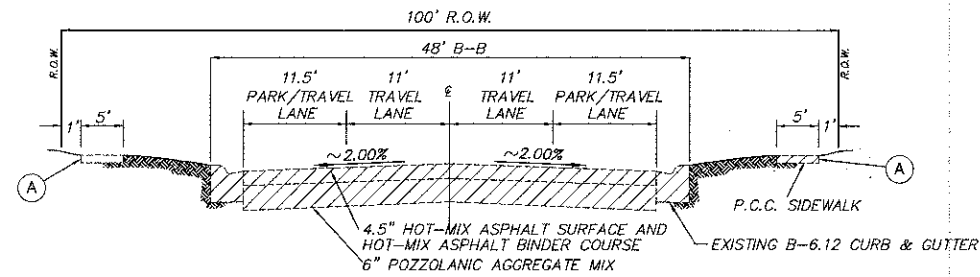

EXISTING PAVEMENT TYPICAL SECTION

STA 23+50 TO 41+50

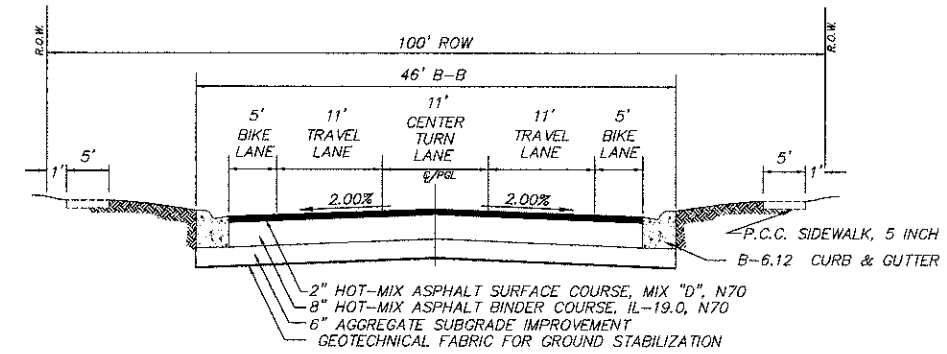

PROPOSED RECONSTRUCTION TYPICAL SECTION

STA 26+00 TO 41+00

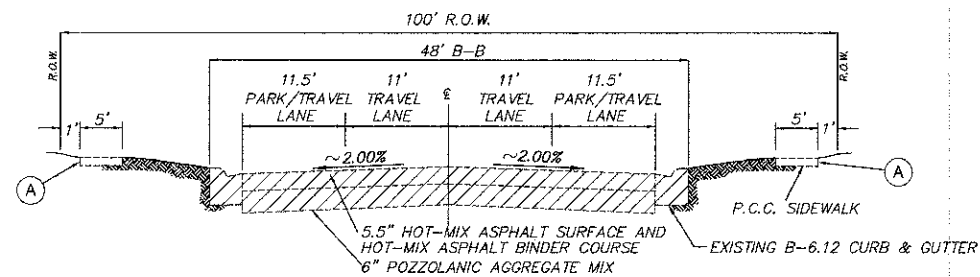

EXISTING PAVEMENT TYPICAL SECTION

STA 41+50 TO 69+00

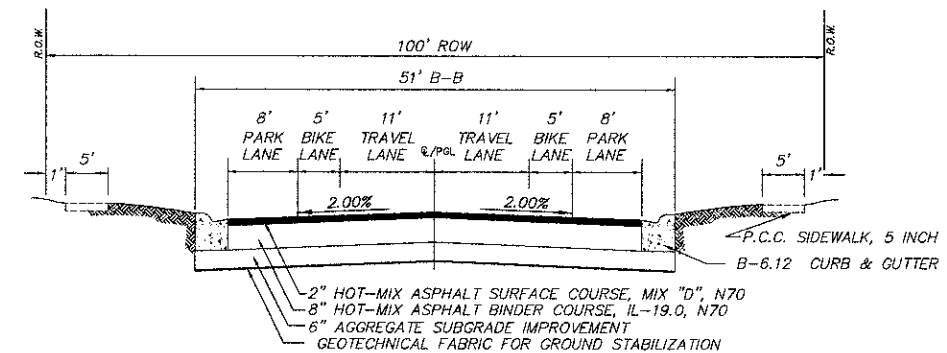

PROPOSED RECONSTRUCTION TYPICAL SECTION

STA 41+00 TO 70+00

LEGEND



REMOVAL



REMOVAL AT LOCATIONS SHOWN ON THE PLANS AND DETERMINED BY ENGINEER

HASSELL ROAD

HOT-MIX ASPHALT MIXTURE REQUIREMENT	
MIXTURE TYPE	AIR VOIDS @ Ndes
FULL DEPTH PAVEMENT	
HOT-MIX ASPHALT SURFACE COURSE, MIX "D", N70 (IL-9.5 mm); 2"	4% @ 70 GYR
HOT-MIX ASPHALT BINDER COURSE, IL-19.0 N70; 8" (2 LIFT MINIMUM)	4% @ 70 GYR
PAVEMENT RESURFACING	
HOT-MIX ASPHALT SURFACE COURSE, MIX "D", N70 (IL-9.5 mm); 2"	4% @ 70 GYR
LEVELING BINDER (MACHINE METHOD), N70 (IL-9.5 mm); 3/4"	4% @ 70 GYR
DRIVEWAYS	
HOT-MIX ASPHALT SURFACE COURSE, MIX "D", N50 (IL-9.5 mm); 2"	4% @ 50 GYR
HOT-MIX ASPHALT BINDER COURSE, IL-19.0 N50; 3"	4% @ 50 GYR
PATCHING	
CLASS D PATCHES (HMA BINDER, IL-19.0 mm); 8 INCH (2 LIFTS)	4% @ 70 GYR

NOTE: THE UNIT WEIGHT USED TO CALCULATE ALL HOT-MIX ASPHALT SURFACE MIXTURES IS 112 LBS/SQ YD/IN. THE "AC TYPE" FOR POLYMERIZED HMA MIXES SHALL BE "SBS/SBR PG 76-22" AND FOR NON POLYMERIZED HMA SHALL BE "PG 64-22" UNLESS MODIFIED BY DISTRICT ONE SPECIAL PROVISIONS. FOR USE OF RECYCLED MATERIALS SEE DISTRICT ONE SPECIAL PROVISIONS.

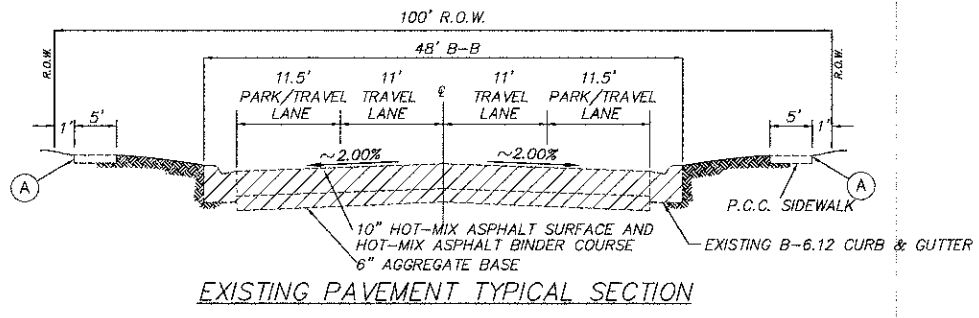

STA 69+00 TO 70+14

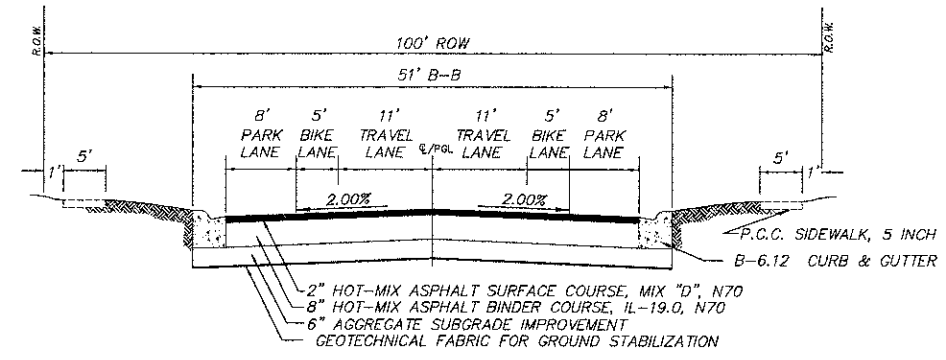

PROPOSED RECONSTRUCTION TYPICAL SECTION

STA 41+00 TO 70+14

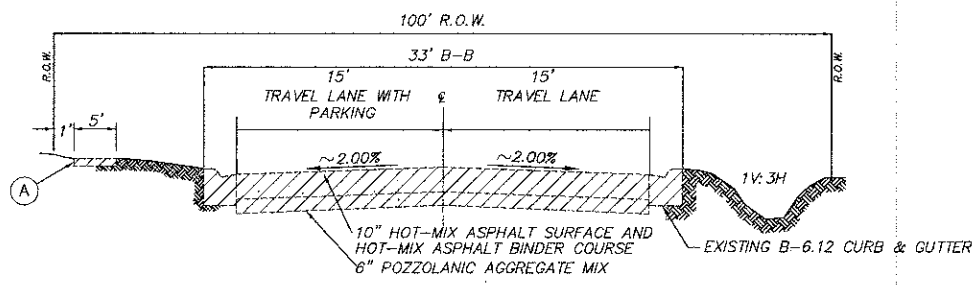

STA 70+14 TO 77+25

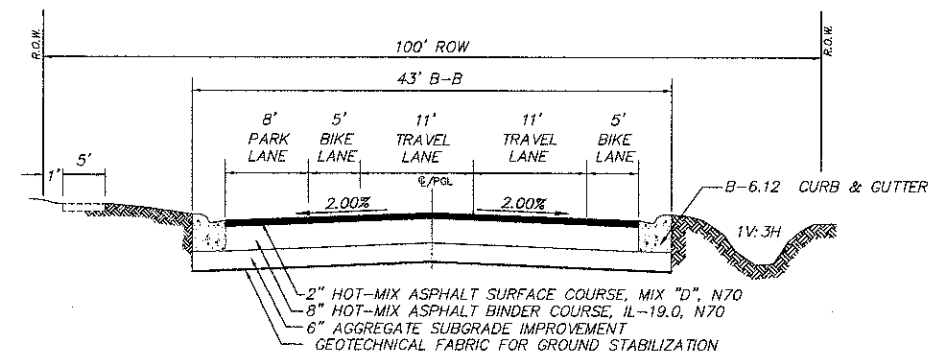

PROPOSED RECONSTRUCTION TYPICAL SECTION

STA 70+14 TO 73+00

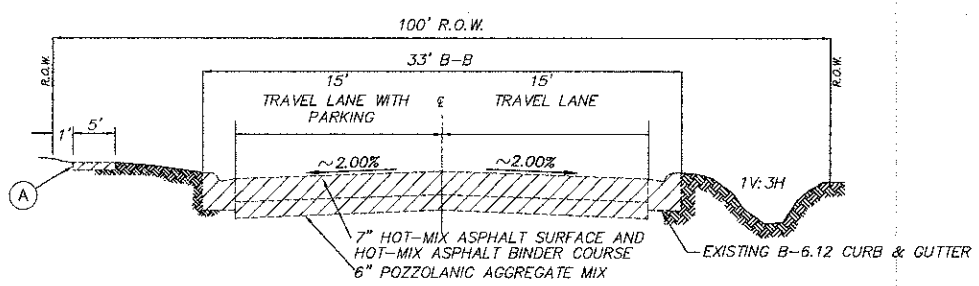

STA 77+25 TO 88+35

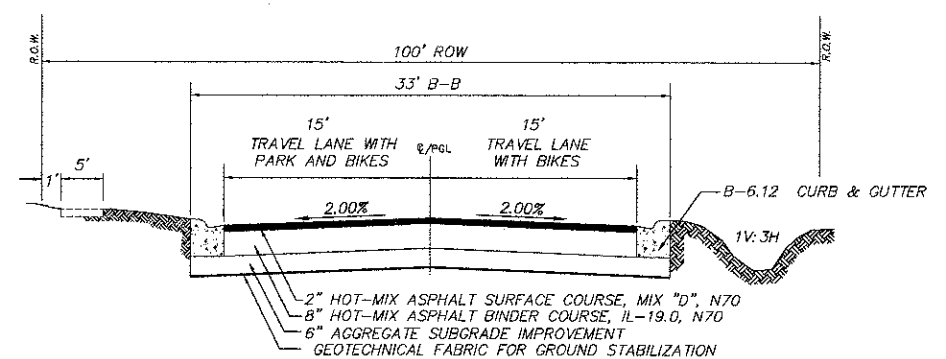

PROPOSED RECONSTRUCTION TYPICAL SECTION

STA 73+00 TO 88+35

HASSELL ROAD

HOT-MIX ASPHALT MIXTURE REQUIREMENT	
MIXTURE TYPE	AIR VOIDS @ Ndes
FULL DEPTH PAVEMENT	
HOT-MIX ASPHALT SURFACE COURSE, MIX "D", N70 (IL-9.5 mm); 2"	4% @ 70 GYR
HOT-MIX ASPHALT BINDER COURSE, IL-19.0 N70; 8" (2 LIFT MINIMUM)	4% @ 70 GYR
PAVEMENT RESURFACING	
HOT-MIX ASPHALT SURFACE COURSE, MIX "D", N70 (IL-9.5 mm); 2"	4% @ 70 GYR
LEVELING BINDER (MACHINE METHOD), N70 (IL-9.5 mm); 3/4"	4% @ 70 GYR
DRIVEWAYS	
HOT-MIX ASPHALT SURFACE COURSE, MIX "D", N50 (IL-9.5 mm); 2"	4% @ 50 GYR
HOT-MIX ASPHALT BINDER COURSE, IL-19.0 N50; 3"	4% @ 50 GYR
PATCHING	
CLASS D PATCHES (HMA BINDER, IL-19.0 mm); 8 INCH (2 LIFTS)	4% @ 70 GYR

NOTE: THE UNIT WEIGHT USED TO CALCULATE ALL HOT-MIX ASPHALT SURFACE MIXTURES IS 112 LBS/SQ YD/IN. THE "AC TYPE" FOR POLYMERIZED HMA MIXES SHALL BE "SBS/SBR PG 76-22" AND FOR NON POLYMERIZED HMA SHALL BE "PG 64-22" UNLESS MODIFIED BY DISTRICT ONE SPECIAL PROVISIONS. FOR USE OF RECYCLED MATERIALS SEE DISTRICT ONE SPECIAL PROVISIONS.

LEGEND

- REMOVAL
- REMOVAL AT LOCATIONS SHOWN ON THE PLANS AND DETERMINED BY ENGINEER

FILE NAME =	DESIGNED --	REVISED --
DETAILS.DWG	DRAWN --	REVISED --
	CHECKED --	REVISED --
	DATE --	REVISED --

STATE OF ILLINOIS
DEPARTMENT OF TRANSPORTATION

Hassell Road STP Project
Typical Section

SCALE: NONE SHEET NO. 2 OF 7 SHEETS STA. TO STA.

F.A.U. RTE.	SECTION	COUNTY	TOTAL SHEETS	SHEET NO.
1100	11-00087-00-FP	Cook	164	9
CONTRACT NO. 63770				
ILLINOIS FED. AID PROJECT CMM 9003(757)				

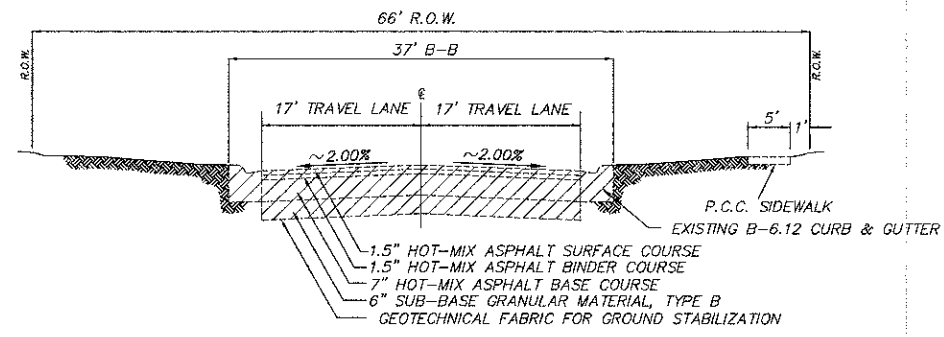

EXISTING PAVEMENT TYPICAL SECTION

PEMBROKE AVENUE
STA 13+86

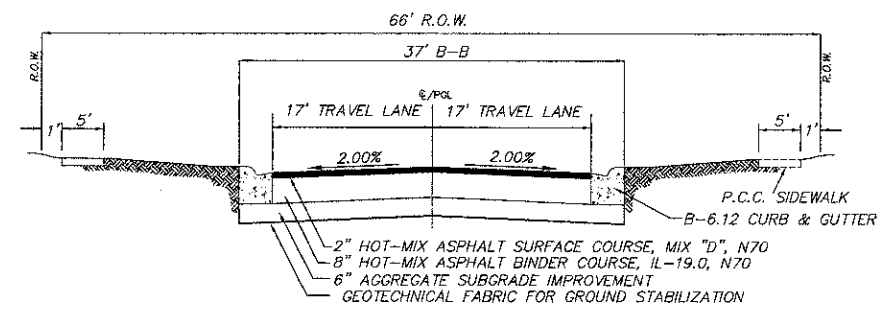

PROPOSED RECONSTRUCTION TYPICAL SECTION

PEMBROKE AVENUE
STA 13+86

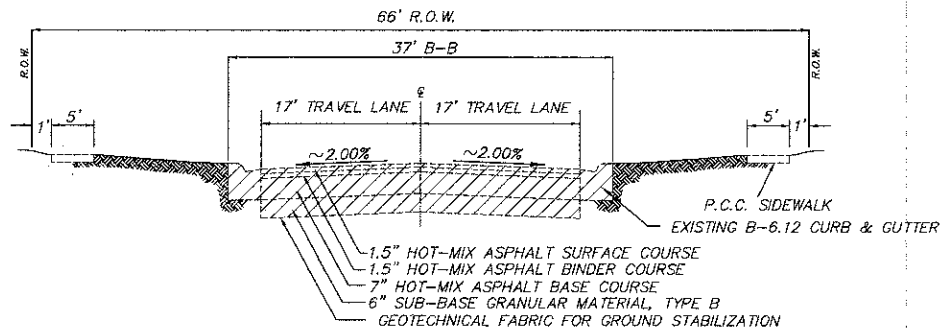

EXISTING PAVEMENT TYPICAL SECTION

STONINGTON AVENUE
STA 18+94

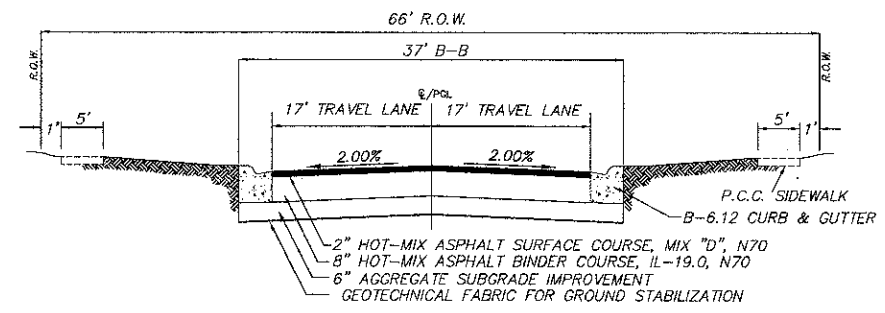

PROPOSED RECONSTRUCTION TYPICAL SECTION

STONINGTON AVENUE
STA 18+94

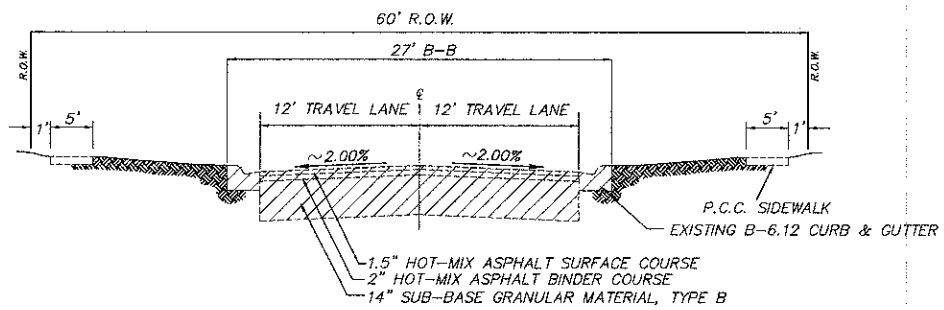

EXISTING PAVEMENT TYPICAL SECTION

BLACKBERRY LANE
STA 38+21

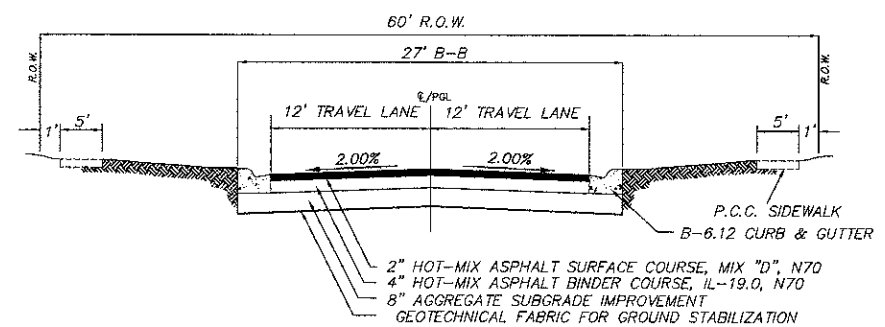

PROPOSED RECONSTRUCTION TYPICAL SECTION

BLACKBERRY LANE
STA 38+21

PEMBROKE AVENUE AND STONINGTON AVENUE

HOT-MIX ASPHALT MIXTURE REQUIREMENT	
MIXTURE TYPE	AIR VOIDS @ Ndes
FULL DEPTH PAVEMENT	
HOT-MIX ASPHALT SURFACE COURSE, MIX "D", N70 (IL-9.5 mm); 2"	4% @ 70 GYR
HOT-MIX ASPHALT BINDER COURSE, IL-19.0 N70; 8" (2 LIFT MINIMUM)	4% @ 70 GYR

NOTE: THE UNIT WEIGHT USED TO CALCULATE ALL HOT-MIX ASPHALT SURFACE MIXTURES IS 112 LBS/SQ YD/IN. THE "AC TYPE" FOR POLYMERIZED HMA MIXES SHALL BE "SBS/SBR PG 76-22" AND FOR NON POLYMERIZED HMA SHALL BE "PG 64-22" UNLESS MODIFIED BY DISTRICT ONE SPECIAL PROVISIONS. FOR USE OF RECYCLED MATERIALS SEE DISTRICT ONE SPECIAL PROVISIONS.

LEGEND

REMOVAL

BLACKBERRY LANE

HOT-MIX ASPHALT MIXTURE REQUIREMENT	
MIXTURE TYPE	AIR VOIDS @ Ndes
FULL DEPTH PAVEMENT	
HOT-MIX ASPHALT SURFACE COURSE, MIX "D", N70 (IL-9.5 mm); 2"	4% @ 70 GYR
HOT-MIX ASPHALT BINDER COURSE, IL-19.0 N70; 4"	4% @ 70 GYR

NOTE: THE UNIT WEIGHT USED TO CALCULATE ALL HOT-MIX ASPHALT SURFACE MIXTURES IS 112 LBS/SQ YD/IN. THE "AC TYPE" FOR POLYMERIZED HMA MIXES SHALL BE "SBS/SBR PG 76-22" AND FOR NON POLYMERIZED HMA SHALL BE "PG 64-22" UNLESS MODIFIED BY DISTRICT ONE SPECIAL PROVISIONS. FOR USE OF RECYCLED MATERIALS SEE DISTRICT ONE SPECIAL PROVISIONS.

FILE NAME =	DESIGNED --	REVISED --
DETAILS.DWG	DRAWN --	REVISED --
	CHECKED --	REVISED --
	DATE --	REVISED --

STATE OF ILLINOIS
DEPARTMENT OF TRANSPORTATION

Hassell Road STP Project
Typical Section

SCALE: NONE	SHEET NO. 3 OF 7 SHEETS	STA.	TO STA.	F.A.U. RTE. 1100	SECTION 11-00087-00-FP	COUNTY Cook	TOTAL SHEETS 164	SHEET NO. 10
							CONTRACT NO. 63770	
ILLINOIS FED. AID PROJECT CMM 9003(757)								

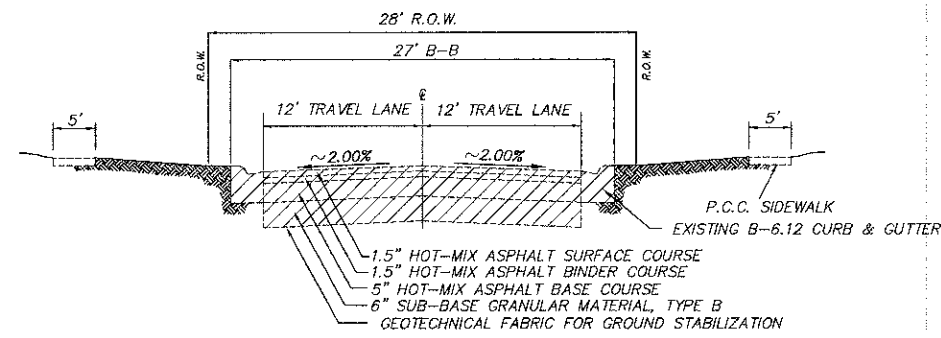

EXISTING PAVEMENT TYPICAL SECTION

HOLBROOK LANE
STA 41+09

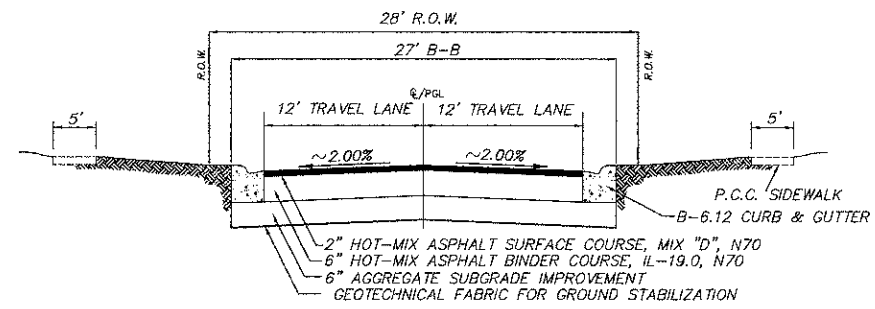

PROPOSED RECONSTRUCTION TYPICAL SECTION

HOLBROOK LANE
STA 41+09

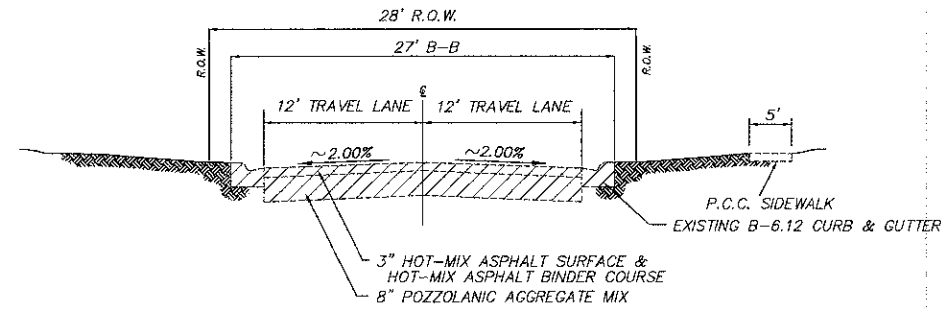

EXISTING PAVEMENT TYPICAL SECTION

CARDIGAN PLACE
STA 44+11

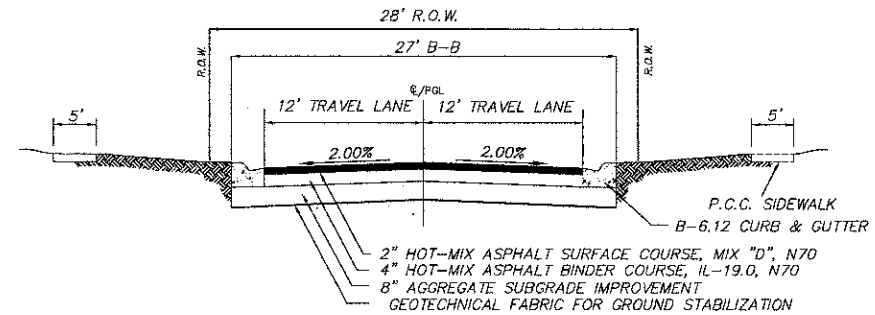

PROPOSED RECONSTRUCTION TYPICAL SECTION

CARDIGAN PLACE
STA 44+11

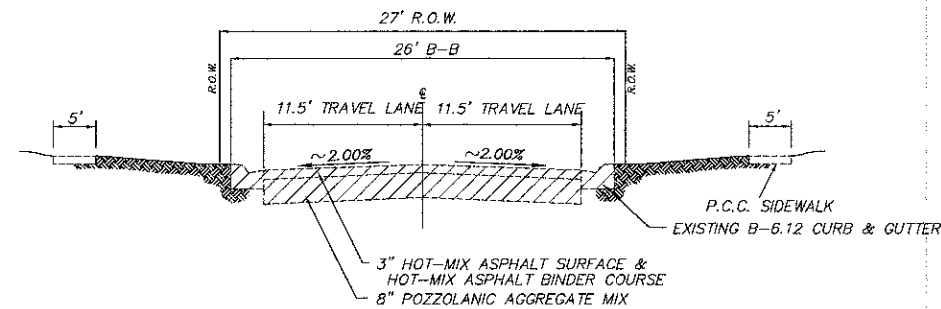

EXISTING PAVEMENT TYPICAL SECTION

BRIGHTON LANE
STA 46+30

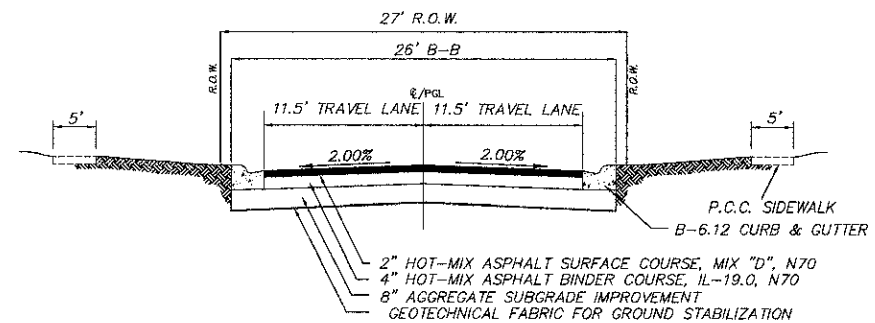

PROPOSED RECONSTRUCTION TYPICAL SECTION

BRIGHTON LANE
STA 46+30

LEGEND

REMOVAL

HOT-MIX ASPHALT MIXTURE REQUIREMENT	
MIXTURE TYPE	AIR VOIDS @ Ndes
FULL DEPTH PAVEMENT	
HOT-MIX ASPHALT SURFACE COURSE, MIX "D", N70 (IL-9.5 mm); 2"	4% @ 70 GYR
HOT-MIX ASPHALT BINDER COURSE, IL-19.0 N70; 6" (2 LIFT MINIMUM)	4% @ 70 GYR

NOTE: THE UNIT WEIGHT USED TO CALCULATE ALL HOT-MIX ASPHALT SURFACE MIXTURES IS 112 LBS/SQ YD/IN. THE "AC TYPE" FOR POLYMERIZED HMA MIXES SHALL BE "SBS/SBR PG 76-22" AND FOR NON POLYMERIZED HMA SHALL BE "PG 64-22" UNLESS MODIFIED BY DISTRICT ONE SPECIAL PROVISIONS. FOR USE OF RECYCLED MATERIALS SEE DISTRICT ONE SPECIAL PROVISIONS.

HOT-MIX ASPHALT MIXTURE REQUIREMENT	
MIXTURE TYPE	AIR VOIDS @ Ndes
FULL DEPTH PAVEMENT	
HOT-MIX ASPHALT SURFACE COURSE, MIX "D", N70 (IL-9.5 mm); 2"	4% @ 70 GYR
HOT-MIX ASPHALT BINDER COURSE, IL-19.0 N70; 4"	4% @ 70 GYR

NOTE: THE UNIT WEIGHT USED TO CALCULATE ALL HOT-MIX ASPHALT SURFACE MIXTURES IS 112 LBS/SQ YD/IN. THE "AC TYPE" FOR POLYMERIZED HMA MIXES SHALL BE "SBS/SBR PG 76-22" AND FOR NON POLYMERIZED HMA SHALL BE "PG 64-22" UNLESS MODIFIED BY DISTRICT ONE SPECIAL PROVISIONS. FOR USE OF RECYCLED MATERIALS SEE DISTRICT ONE SPECIAL PROVISIONS.

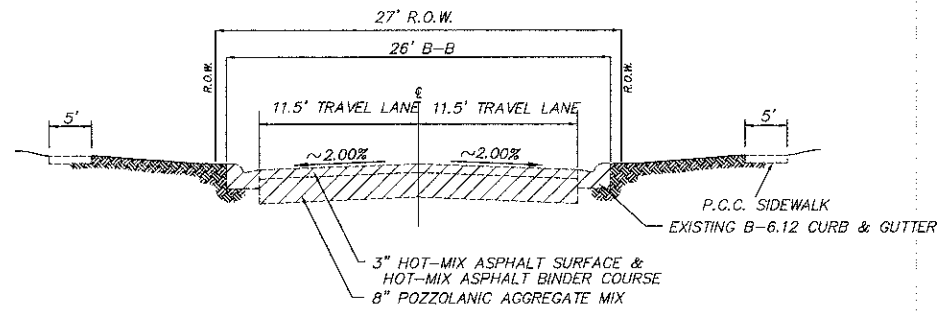

EXISTING PAVEMENT TYPICAL SECTION

OXFORD LANE
STA 48+41

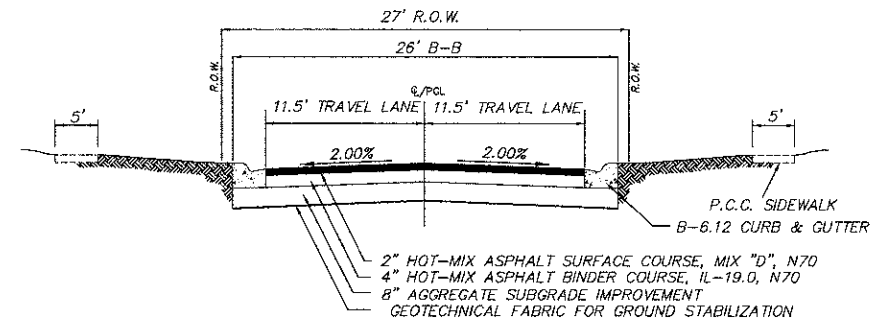

PROPOSED RECONSTRUCTION TYPICAL SECTION

OXFORD LANE
STA 48+41

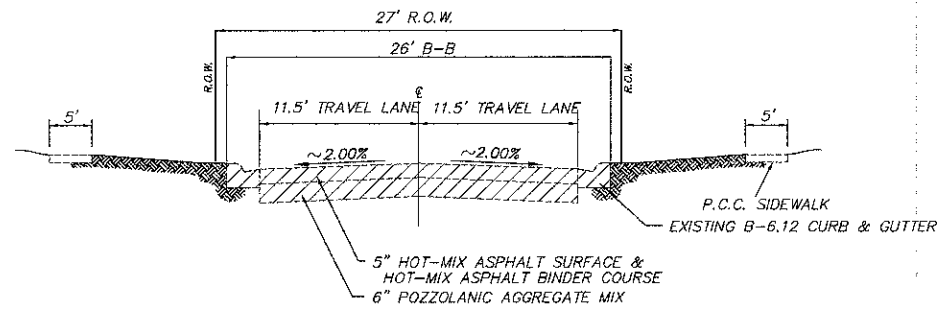

EXISTING PAVEMENT TYPICAL SECTION

GEORGETOWN LANE
STA 50+57

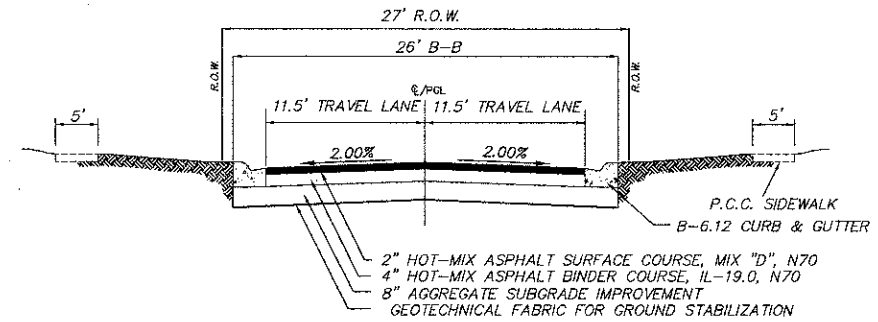

PROPOSED RECONSTRUCTION TYPICAL SECTION

GEORGETOWN LANE
STA 50+57

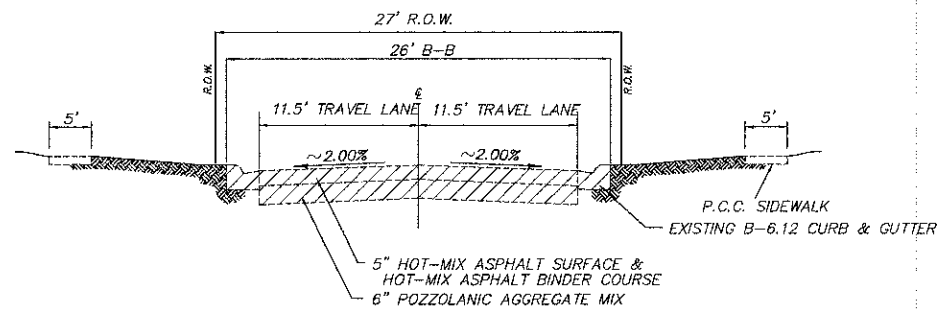

EXISTING PAVEMENT TYPICAL SECTION

ERIE LANE
STA 52+68

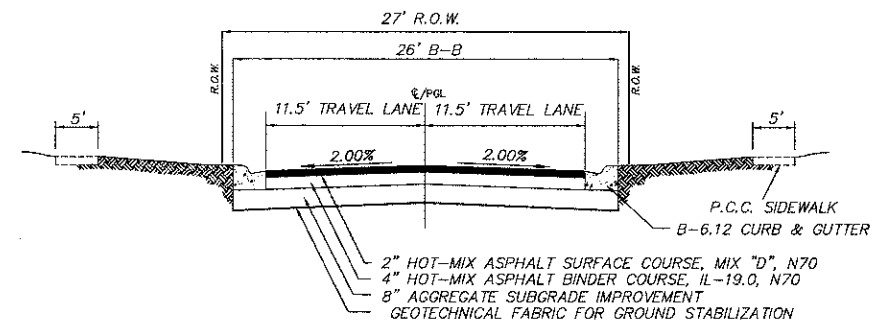

PROPOSED RECONSTRUCTION TYPICAL SECTION

ERIE LANE
STA 52+68

LEGEND

REMOVAL

ERIE LANE, GEORGETOWN LANE, OXFORD LANE

HOT-MIX ASPHALT MIXTURE REQUIREMENT	
MIXTURE TYPE	AIR VOIDS @ Ndes
FULL DEPTH PAVEMENT	
HOT-MIX ASPHALT SURFACE COURSE, MIX "D", N70 (IL-9.5 mm); 2"	4% @ 70 GYR
HOT-MIX ASPHALT BINDER COURSE, IL-19.0 N70; 4"	4% @ 70 GYR

NOTE: THE UNIT WEIGHT USED TO CALCULATE ALL HOT-MIX ASPHALT SURFACE MIXTURES IS 112 LBS/SQ YD/IN. THE "AC TYPE" FOR POLYMERIZED HMA MIXES SHALL BE "SBS/SBR PG 76-22" AND FOR NON POLYMERIZED HMA SHALL BE "PG 64-22" UNLESS MODIFIED BY DISTRICT ONE SPECIAL PROVISIONS. FOR USE OF RECYCLED MATERIALS SEE DISTRICT ONE SPECIAL PROVISIONS.

FILE NAME = DETAILSH.DWG	DESIGNED —	REVISED —
	DRAWN —	REVISED —
	CHECKED —	REVISED —
	DATE —	REVISED —

STATE OF ILLINOIS
DEPARTMENT OF TRANSPORTATION

Hassell Road STP Project
Typical Section

SCALE: NONE SHEET NO. 5 OF 7 SHEETS STA. TO STA.

F.A.U. RTE.	SECTION	COUNTY	TOTAL SHEETS	SHEET NO.
1100	11-00087-00-FP	Cook	164	12
CONTRACT NO. 63770				
ILLINOIS FED. AID PROJECT GMM 9003(757)				

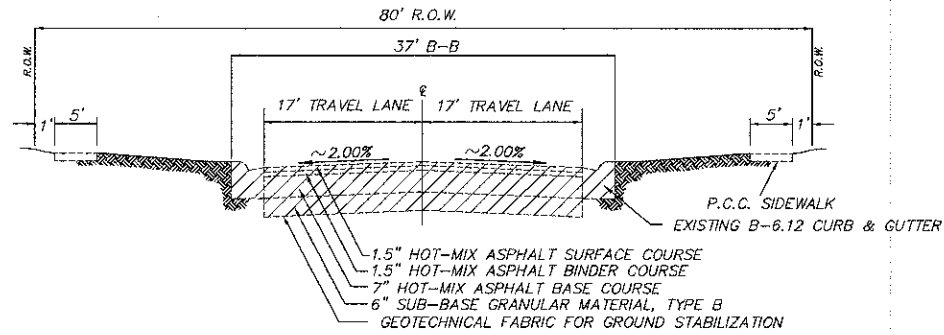

EXISTING PAVEMENT TYPICAL SECTION

KENSINGTON LANE
STA 58+36

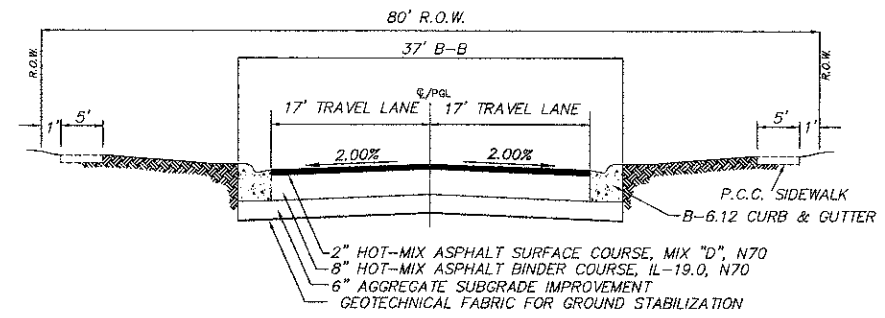

PROPOSED RECONSTRUCTION TYPICAL SECTION

KENSINGTON LANE
STA 58+36

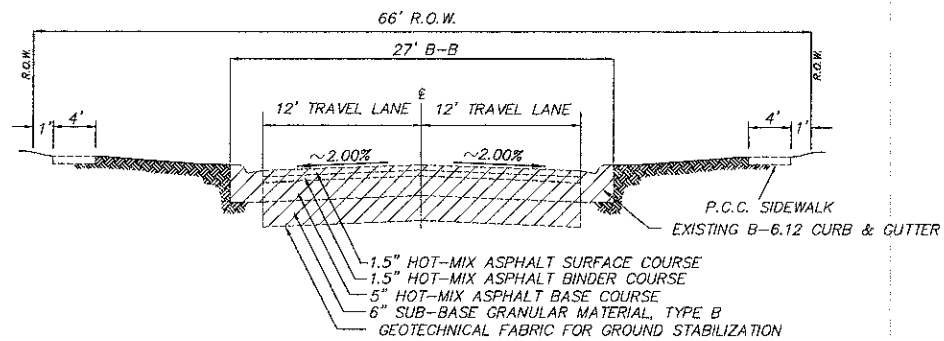

EXISTING PAVEMENT TYPICAL SECTION

PARKVIEW CIRCLE (W)
STA 73+06

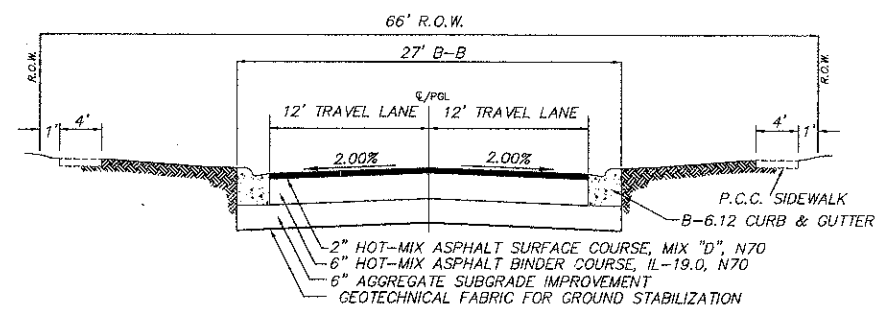

PROPOSED RECONSTRUCTION TYPICAL SECTION

PARKVIEW CIRCLE (W)
STA 73+06

KENSINGTON LANE

HOT-MIX ASPHALT MIXTURE REQUIREMENT	
MIXTURE TYPE	AIR VOIDS @ Ndes
FULL DEPTH PAVEMENT	
HOT-MIX ASPHALT SURFACE COURSE, MIX "D", N70 (IL-9.5 mm); 2"	4% @ 70 GYR
HOT-MIX ASPHALT BINDER COURSE, IL-19.0 N70; 8" (2 LIFT MINIMUM)	4% @ 70 GYR

NOTE: THE UNIT WEIGHT USED TO CALCULATE ALL HOT-MIX ASPHALT SURFACE MIXTURES IS 112 LBS/SQ YD/IN. THE "AC TYPE" FOR POLYMERIZED HMA MIXES SHALL BE "SBS/SBR PG 76-22" AND FOR NON POLYMERIZED HMA SHALL BE "PG 64-22" UNLESS MODIFIED BY DISTRICT ONE SPECIAL PROVISIONS. FOR USE OF RECYCLED MATERIALS SEE DISTRICT ONE SPECIAL PROVISIONS.

PARKVIEW CIRCLE (W)

HOT-MIX ASPHALT MIXTURE REQUIREMENT	
MIXTURE TYPE	AIR VOIDS @ Ndes
FULL DEPTH PAVEMENT	
HOT-MIX ASPHALT SURFACE COURSE, MIX "D", N70 (IL-9.5 mm); 2"	4% @ 70 GYR
HOT-MIX ASPHALT BINDER COURSE, IL-19.0 N70; 6" (2 LIFT MINIMUM)	4% @ 70 GYR

NOTE: THE UNIT WEIGHT USED TO CALCULATE ALL HOT-MIX ASPHALT SURFACE MIXTURES IS 112 LBS/SQ YD/IN. THE "AC TYPE" FOR POLYMERIZED HMA MIXES SHALL BE "SBS/SBR PG 76-22" AND FOR NON POLYMERIZED HMA SHALL BE "PG 64-22" UNLESS MODIFIED BY DISTRICT ONE SPECIAL PROVISIONS. FOR USE OF RECYCLED MATERIALS SEE DISTRICT ONE SPECIAL PROVISIONS.

LEGEND

REMOVAL

FILE NAME =	DESIGNED --	REVISED --
DETAILSH.DWG	DRAWN --	REVISED --
	CHECKED --	REVISED --
	DATE --	REVISED --

**STATE OF ILLINOIS
DEPARTMENT OF TRANSPORTATION**

Hassell Road STP Project
Typical Section

SCALE: NONE	SHEET NO. 6 OF 7 SHEETS	STA.	TO STA.	F.A.U. RTE.	SECTION	COUNTY	TOTAL SHEETS	SHEET NO.
				1100	11-00087-00-FP	Cook	164	13
							CONTRACT NO. 63770	
ILLINOIS FED. AID PROJECT CMM 9003(757)								

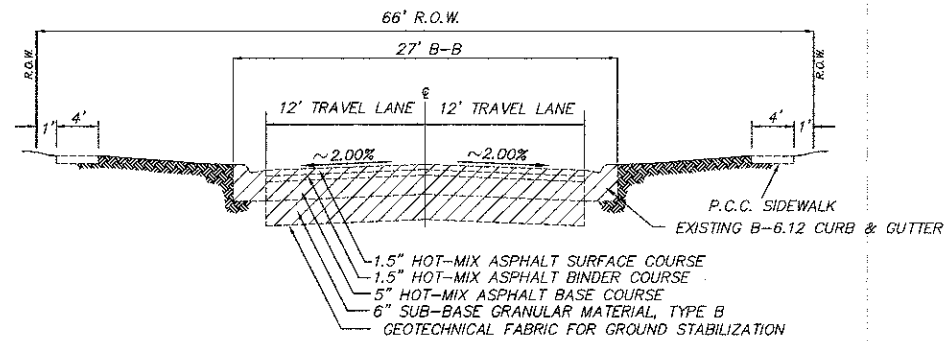

EXISTING PAVEMENT TYPICAL SECTION

PARKVIEW CIRCLE (E)
STA 76+13

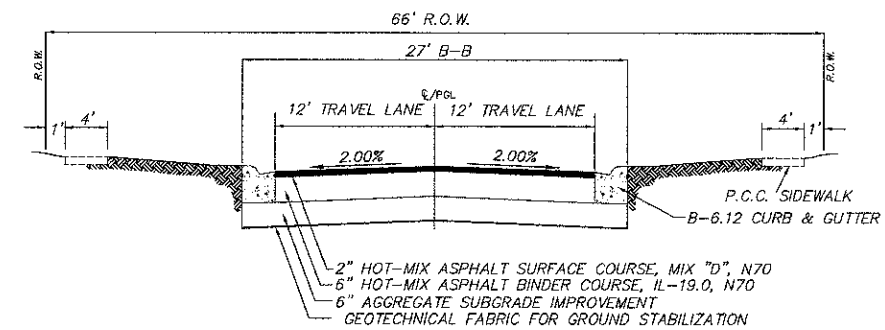

PROPOSED RECONSTRUCTION TYPICAL SECTION

PARKVIEW CIRCLE (E)
STA 76+13

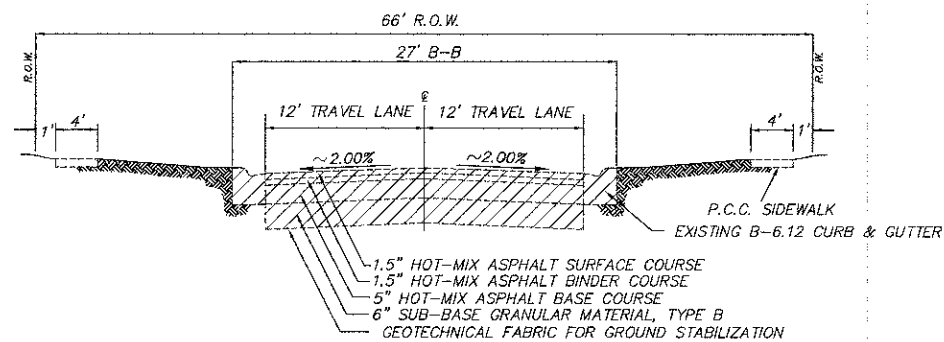

EXISTING PAVEMENT TYPICAL SECTION

ROSEDALE LANE
STA 80+33

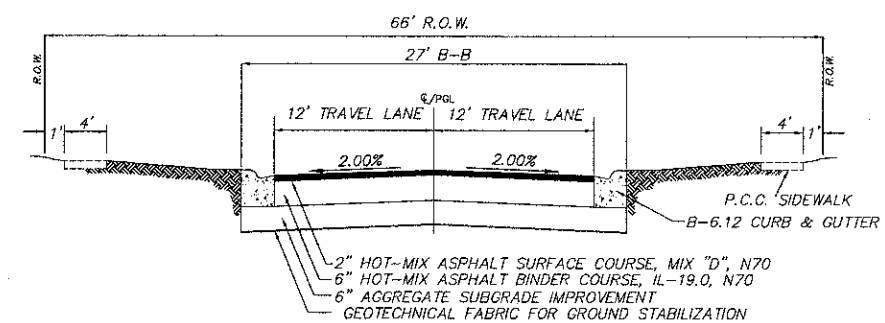

PROPOSED RECONSTRUCTION TYPICAL SECTION

ROSEDALE LANE
STA 80+33

LEGEND

 REMOVAL

PARKVIEW CIRCLE (E), ROSEDALE LANE

HOT-MIX ASPHALT MIXTURE REQUIREMENT	
MIXTURE TYPE	AIR VOIDS @ Ndes
FULL DEPTH PAVEMENT	
HOT-MIX ASPHALT SURFACE COURSE, MIX "D", N70 (IL-9.5 mm); 2"	4% @ 70 GYR
HOT-MIX ASPHALT BINDER COURSE, IL-19.0 N70; 6" (2 LIFT MINIMUM)	4% @ 70 GYR

NOTE: THE UNIT WEIGHT USED TO CALCULATE ALL HOT-MIX ASPHALT SURFACE MIXTURES IS 112 LBS/SQ YD/IN. THE "AC TYPE" FOR POLYMERIZED HMA MIXES SHALL BE "SBS/SBR PG 76-22" AND FOR NON POLYMERIZED HMA SHALL BE "PG 64-22" UNLESS MODIFIED BY DISTRICT ONE SPECIAL PROVISIONS. FOR USE OF RECYCLED MATERIALS SEE DISTRICT ONE SPECIAL PROVISIONS.

FILE NAME =	DESIGNED --	REVISED --
DETAILSH.DWG	DRAWN --	REVISED --
	CHECKED --	REVISED --
	DATE --	REVISED --

**STATE OF ILLINOIS
DEPARTMENT OF TRANSPORTATION**

Hassell Road STP Project
Typical Section

SCALE: NONE SHEET NO. 7 OF 7 SHEETS STA. TO STA.

F.A.U. RTE.	SECTION	COUNTY	TOTAL SHEETS	SHEET NO.
1100	11-00087-00-FP	Cook	164	14
CONTRACT NO. 63770				
ILLINOIS FED. AID PROJECT CMM 9003(757)				

FOR STATION 7+80L TO STATION 12+50L - THE GENERAL CONTRACTOR IS REQUIRED TO HIRE AN ENVIRONMENTAL FIRM WITH AT LEAST FIVE (5) DOCUMENTED LEAKING UNDERGROUND STORAGE TANK CLEANUPS OR THAT IS PRE-QUALIFIED IN HAZARDOUS WASTE BY THE DEPARTMENT TO REMEDIATE THE SOIL CONTAMINATION AND MONITOR FOR WORKER PROTECTION.

PLAN	SURVEYED	DATE	BY
	PLOTTED		
	ALIGNED		
	CHECKED		
	NO.		

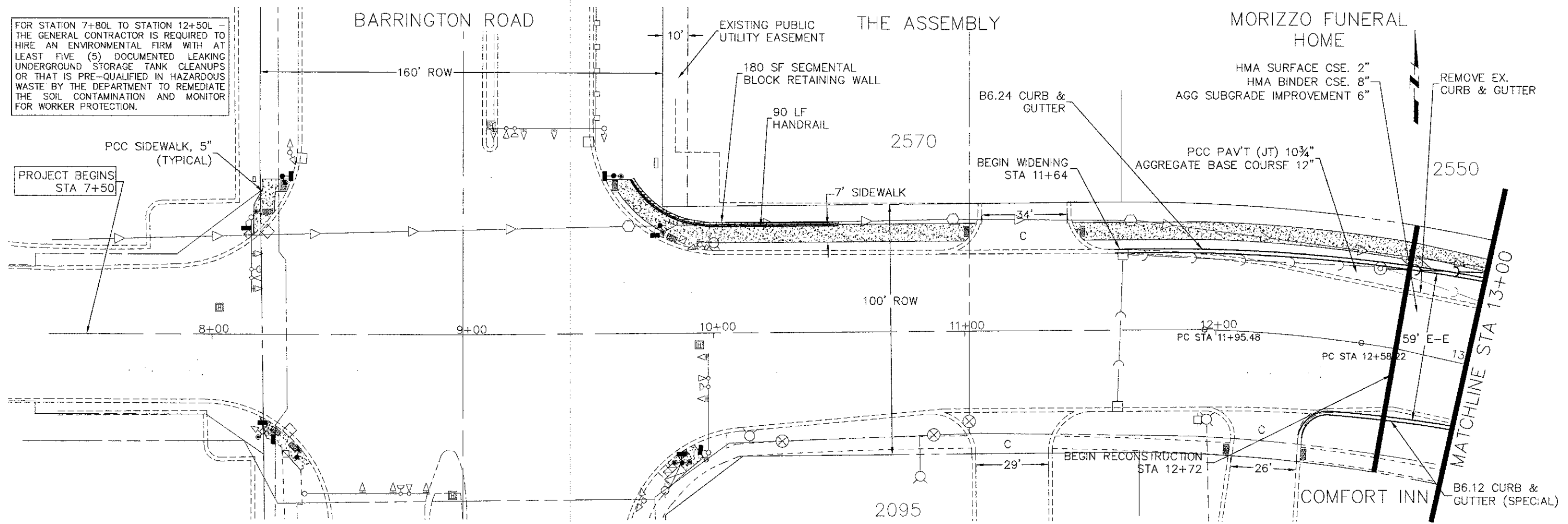

PROFILE	SURVEYED	DATE	BY
	PLOTTED		
	GRADES		
	CHECKED		
	NO.		

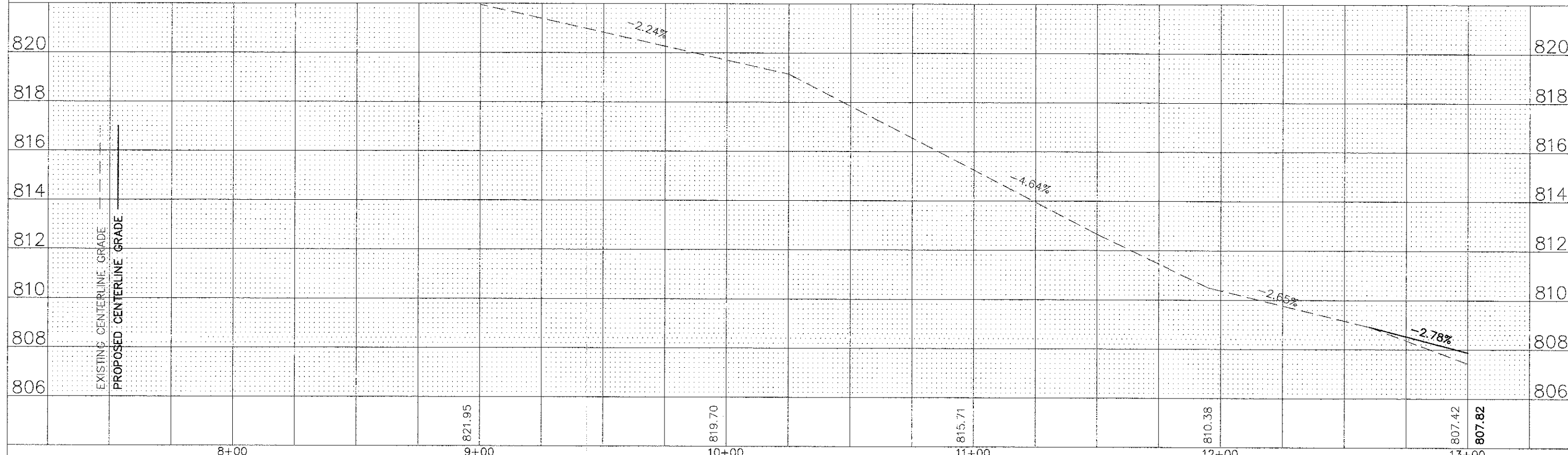

FILE NAME = Hassell Plan-Profile.dwg	DESIGNED -	REVISOR -	F.A.U. RTE. 1100	SECTION 11-00087-00-FP	COUNTY Cook	TOTAL SHEET SHEETS NO. 164 15
	DRAWN -	REVISOR -	Hassell Road STP Project			
	CHECKED -	REVISOR -	Plan and Profile			
	DATE -	REVISOR -	SCALE: 1" = 20'	SHEET NO. 1 OF 16 SHEETS	STA. 8+00 TO STA 13+00	CONTRACT NO. 63770
			ILLINOIS FED. AID PROJECT CMM 9003(757)			

STATE OF ILLINOIS
DEPARTMENT OF TRANSPORTATION

PLAN	DESIGNED	DATE	BY
	PLOTTED		
	GRADES CHECKED		
	NOTES CHECKED		
	NO.		

PROFILE	DESIGNED	DATE	BY
	PLOTTED		
	GRADES CHECKED		
	NOTES CHECKED		
	NO.		

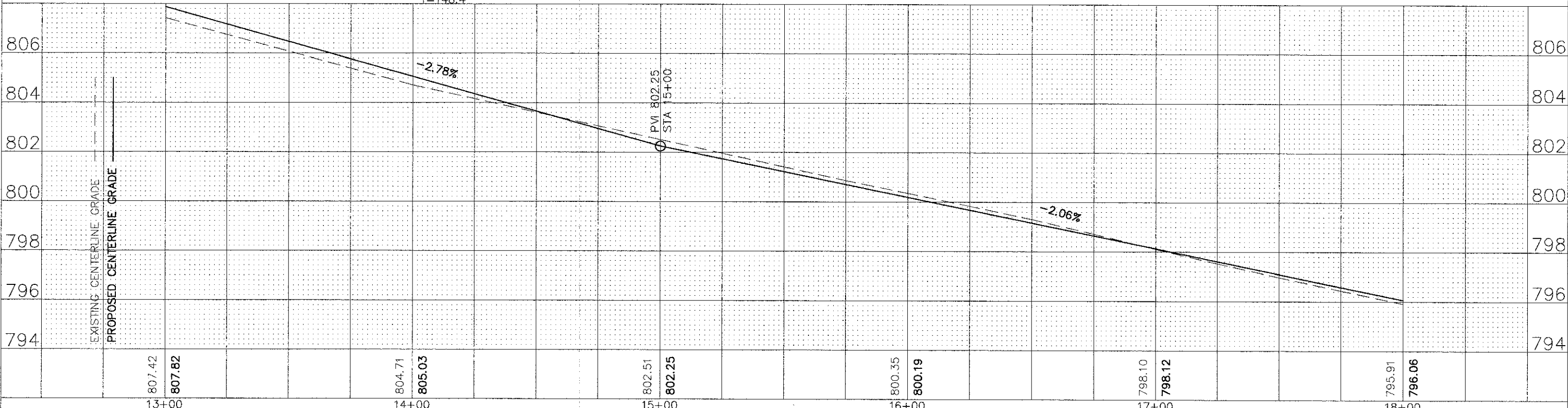
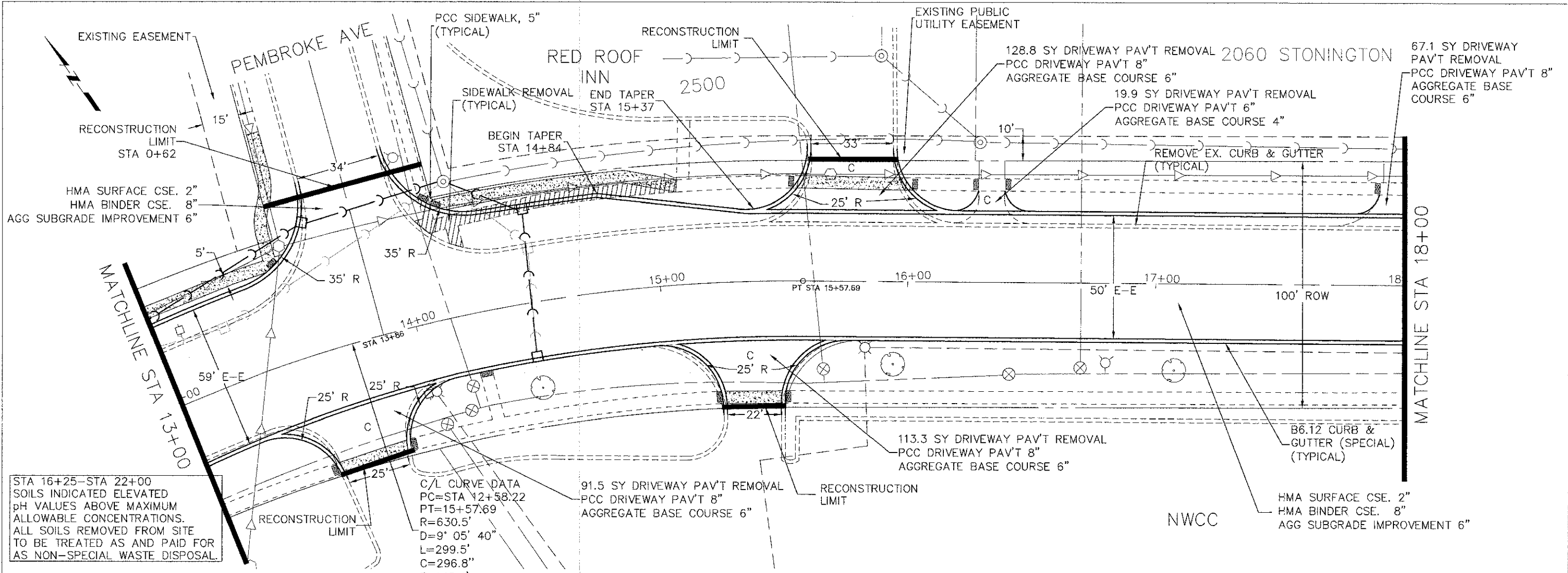

STONINGTON AVENUE

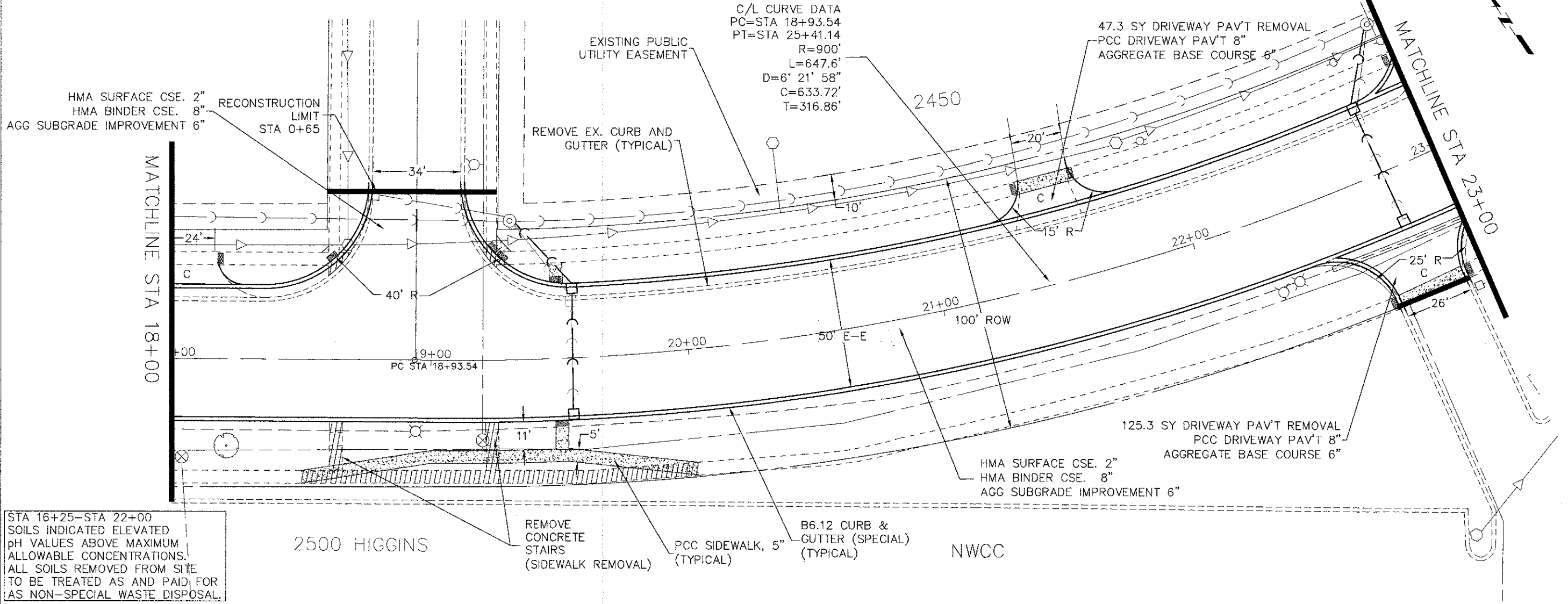

STA 16+25-STA 22+00
SOILS INDICATED ELEVATED
pH VALUES ABOVE MAXIMUM
ALLOWABLE CONCENTRATIONS.
ALL SOILS REMOVED FROM SITE
TO BE TREATED AS AND PAID FOR
AS NON-SPECIAL WASTE DISPOSAL.

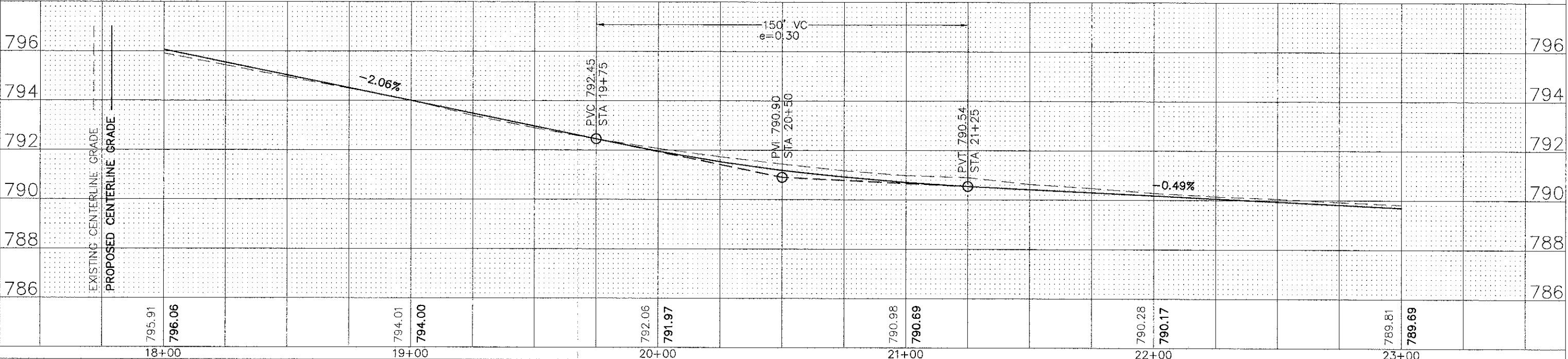

PLAN	DATE	BY
DESIGNED		
DRAWN		
CHECKED		
DATE		

PROFILE	DATE	BY
DESIGNED		
DRAWN		
CHECKED		
DATE		

FILE NAME =	DESIGNED -	REVISED -
Hassell Plan-Profile.dwg	DRAWN -	REVISED -
	CHECKED -	REVISED -
	DATE -	REVISED -

18+00	19+00	20+00	21+00	22+00	23+00
795.91	794.01	792.06	790.98	790.28	789.81
796.06	794.00	791.97	790.69	790.17	789.69

STATE OF ILLINOIS
DEPARTMENT OF TRANSPORTATION

Hassell Road STP Project
Plan and Profile

SCALE: 1" = 20' SHEET NO. 3 OF 16 SHEETS STA. 18+00 TO STA 23+00

F.A.U. RTE.	SECTION	COUNTY	TOTAL SHEETS	SHEET NO.
1100	11-00087-00-FP	Cook	164	17
CONTRACT NO. 63770				ILLINOIS FED. AID PROJECT CMM 9003(757)

STA 31+00-STA 37+00
 SOILS INDICATED ELEVATED
 pH VALUES ABOVE MAXIMUM
 ALLOWABLE CONCENTRATIONS.
 ALL SOILS REMOVED FROM SITE
 TO BE TREATED AS AND PAID FOR
 AS NON-SPECIAL WASTE DISPOSAL.

PLAN
 DESIGNED BY: _____
 CHECKED BY: _____
 DATE: _____
 NO. _____

PROFILE
 DESIGNED BY: _____
 CHECKED BY: _____
 DATE: _____
 NO. _____

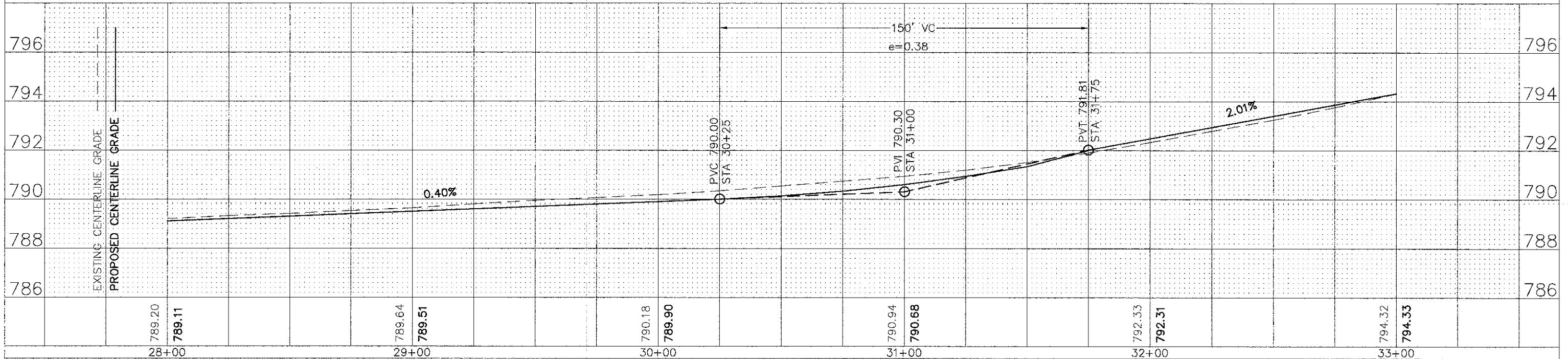
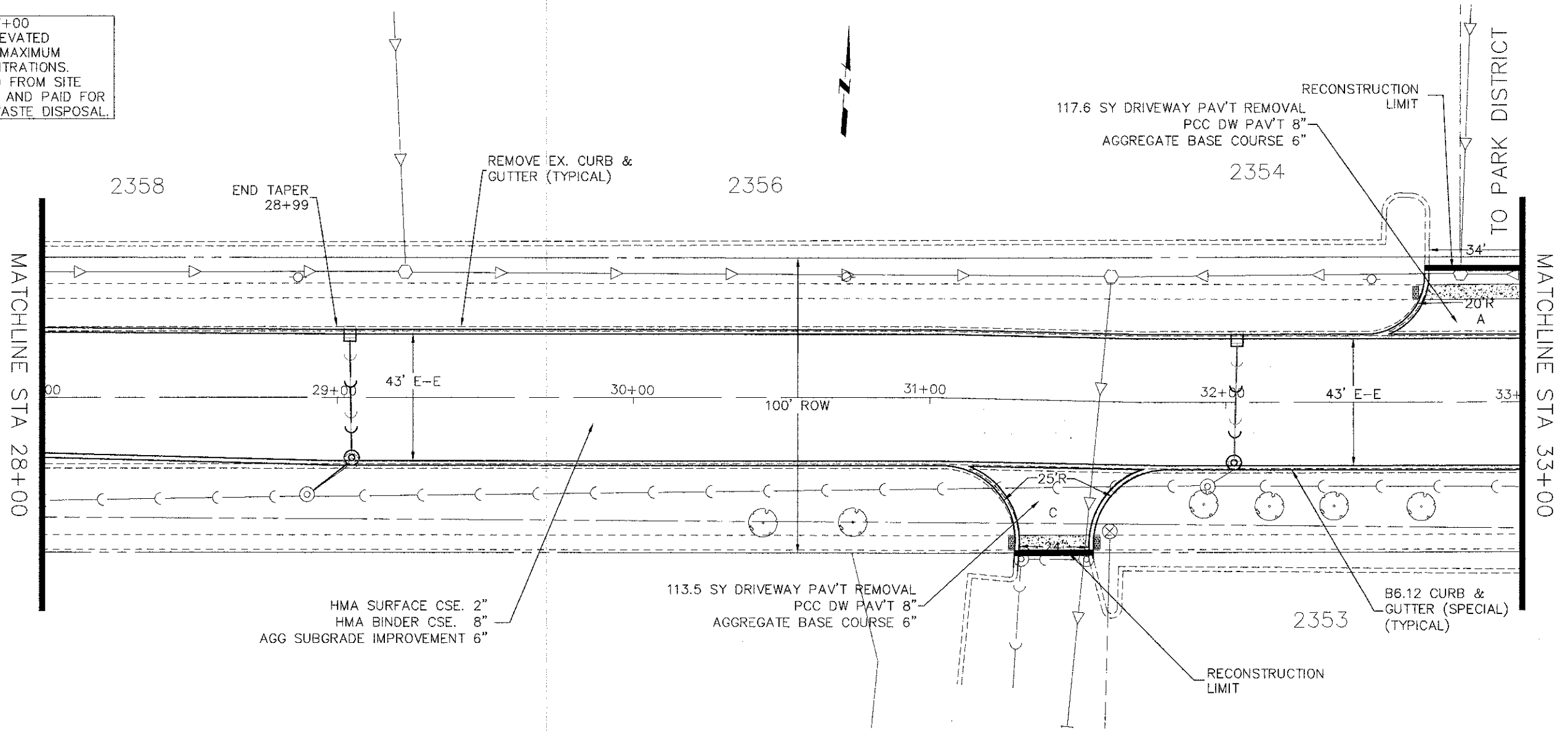

STA 31+00-STA 37+00
 SOILS INDICATED ELEVATED
 pH VALUES ABOVE MAXIMUM
 ALLOWABLE CONCENTRATIONS.
 ALL SOILS REMOVED FROM SITE
 TO BE TREATED AS AND PAID FOR
 AS NON-SPECIAL WASTE DISPOSAL.

POPLAR COMMONS
 MALL

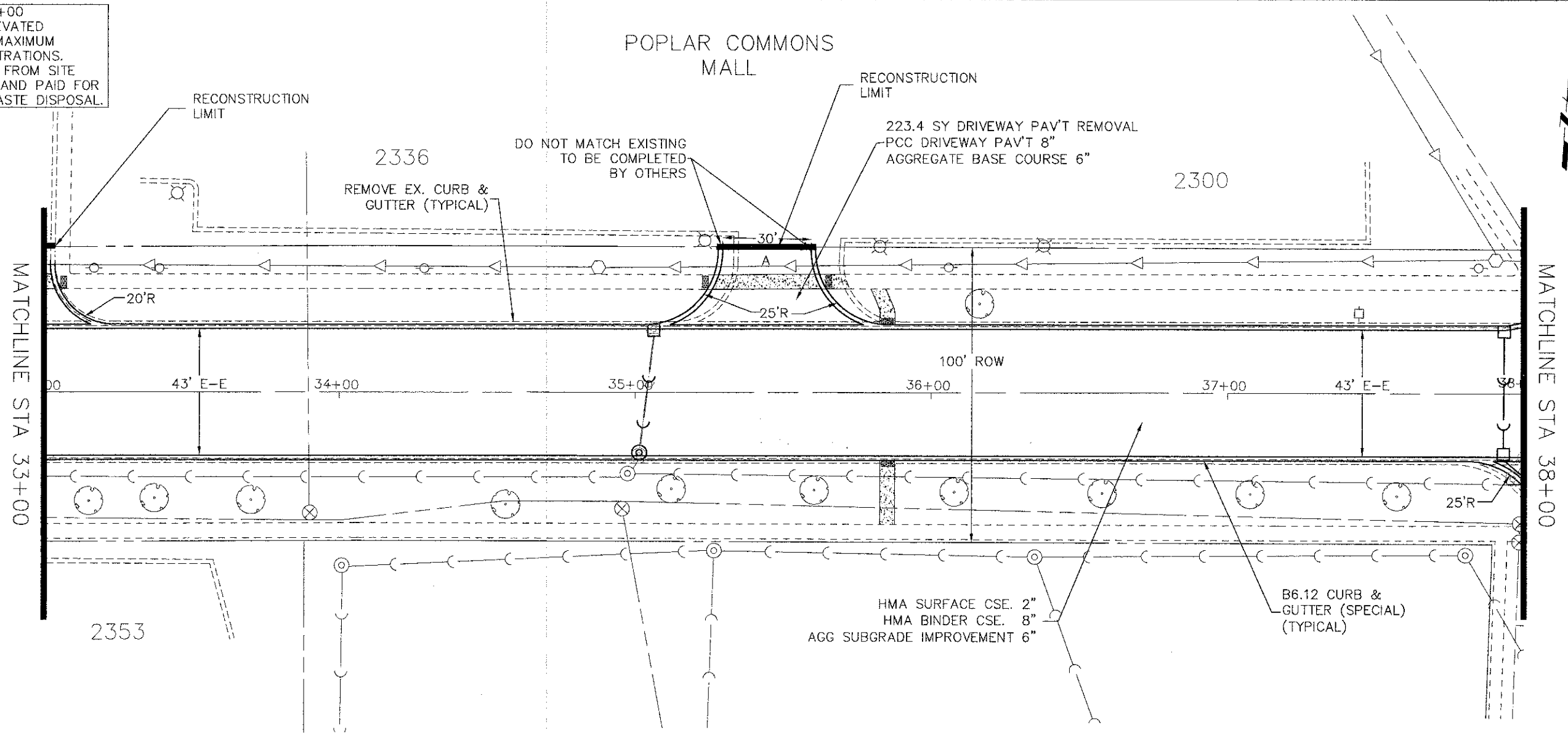

PLAN	SURVEYED	DATE	BY
	NOTE BOOK		
	ALUMINUM CHECKED		
	NO.		
	FILE NO.		
	DATE		
	BY		

PROFILE	SURVEYED	DATE	BY
	NOTE BOOK		
	GRADES CHECKED		
	S.M. NOTED		
	STRUCTURE NOTATIONS CH/NO		
	NO.		
	DATE		
	BY		

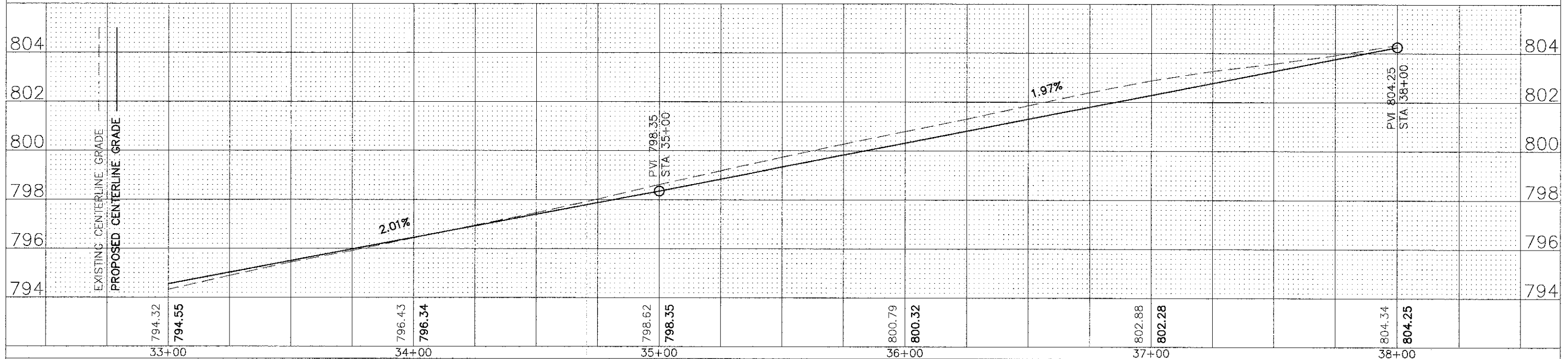

PLAN	SURVEYED	DATE	BY
	NOTE BOOK		
	ALIGNED		
	CHECKED		
	RT. OF WAY		
	CHECKED		
	NO.		

PROFILE	SURVEYED	DATE	BY
	NOTE BOOK		
	GRADES		
	CHECKED		
	E.M. NOTED		
	STRUCTURE		
	NOTAINS		
	CHAD		
	NO.		

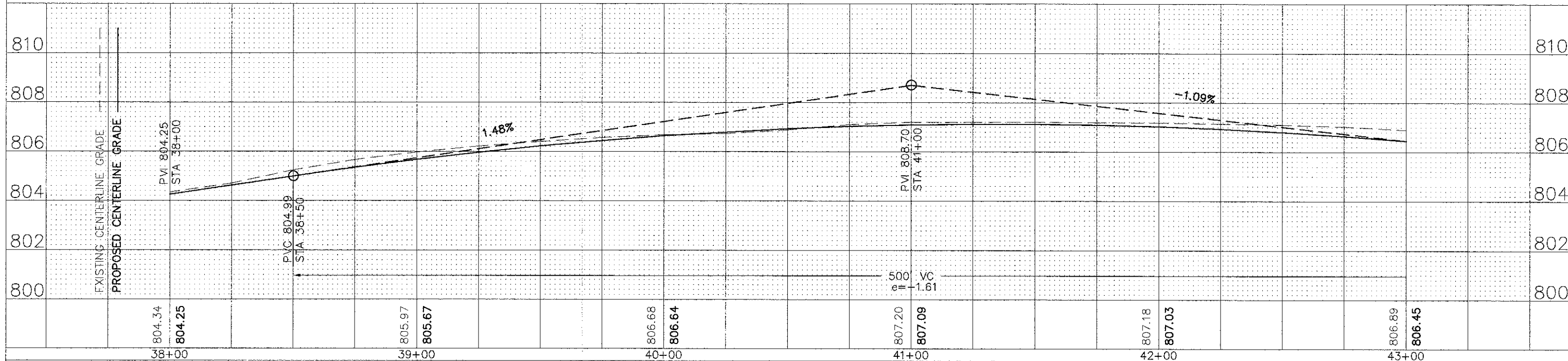
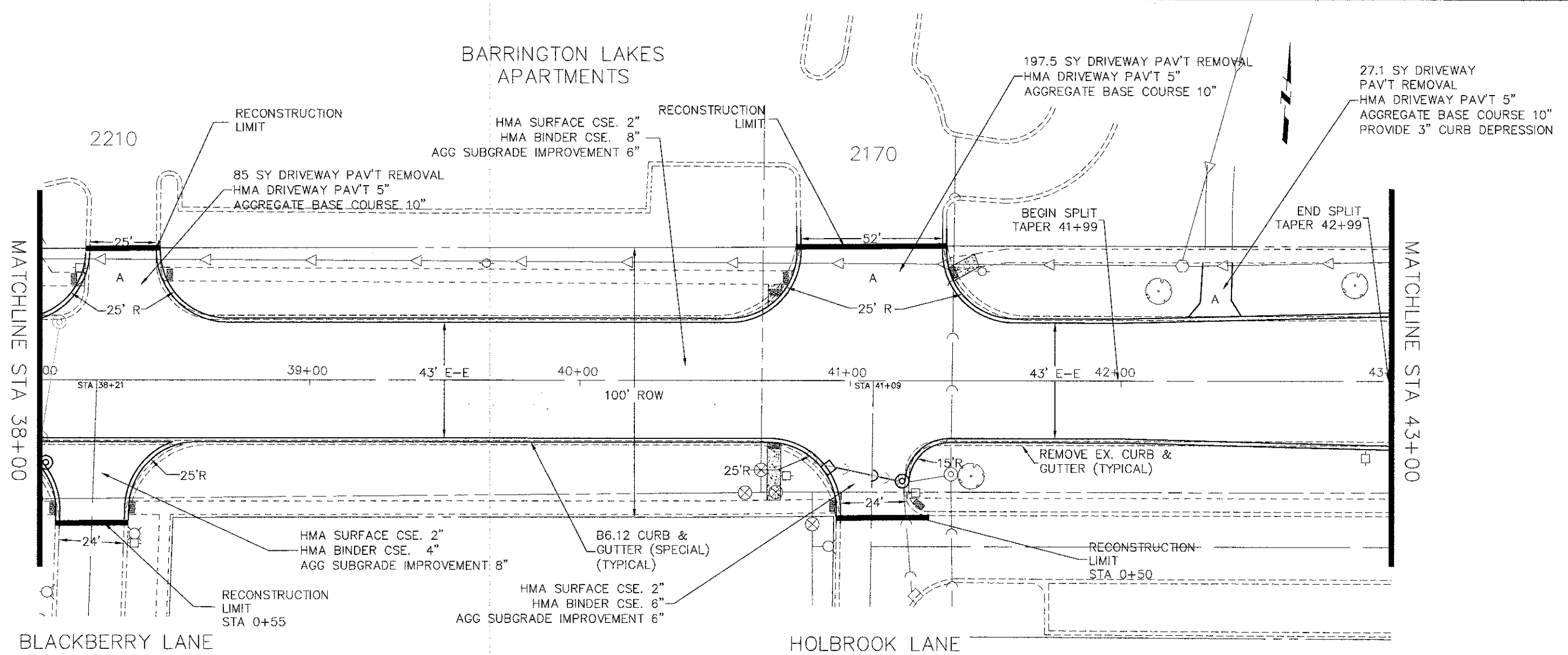

FILE NAME = Hassell Plan-Profile.dwg	DESIGNED -	REVISED -	STATE OF ILLINOIS DEPARTMENT OF TRANSPORTATION	Hassell Road STP Project Plan and Profile		F.A.U. RTE. 1100	SECTION 11-00087-00-FP	COUNTY Cook	TOTAL SHEETS 164	SHEET NO. 21
	DRAWN -	REVISED -		SCALE: 1" = 20'	SHEET NO. 7 OF 16 SHEETS	STA. 38+00 TO STA 43+00	CONTRACT NO. 63770		ILLINOIS FED. AID PROJECT GMM 9003(757)	
	CHECKED -	REVISED -								
	DATE -	REVISED -								

HMA SURFACE CSE. 2"
 HMA BINDER CSE. 8"
 AGG SUBGRADE IMPROVEMENT 6"

2170

BARRINGTON LAKES
 APARTMENTS

2120



MATCHLINE STA 43+00

MATCHLINE STA 48+00

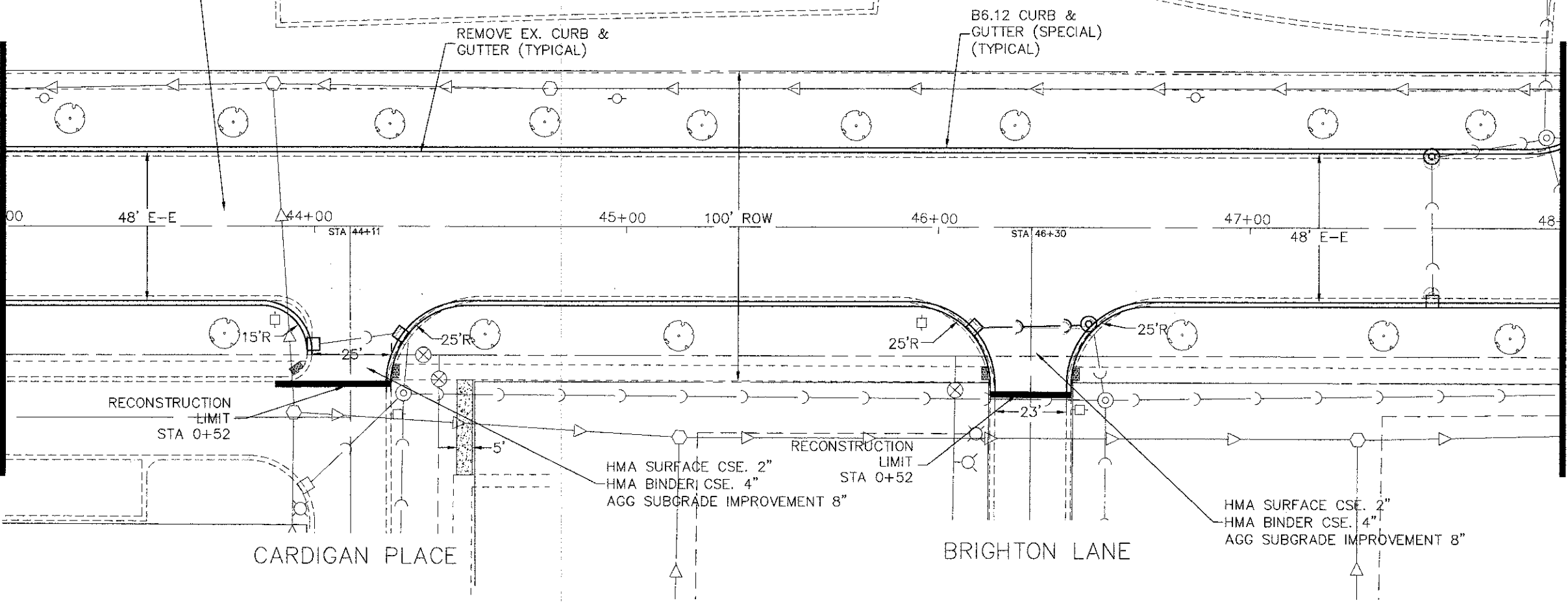

PLAN SURVEYED
 PLOTTED
 NOTE BOOK
 NO. OF MAN CHECKED
 CADFILE NAME

PROFILE SURVEYED
 PLOTTED
 NOTE BOOK
 NO. OF MAN CHECKED
 STRUCTURE NOTATIONS OK'D

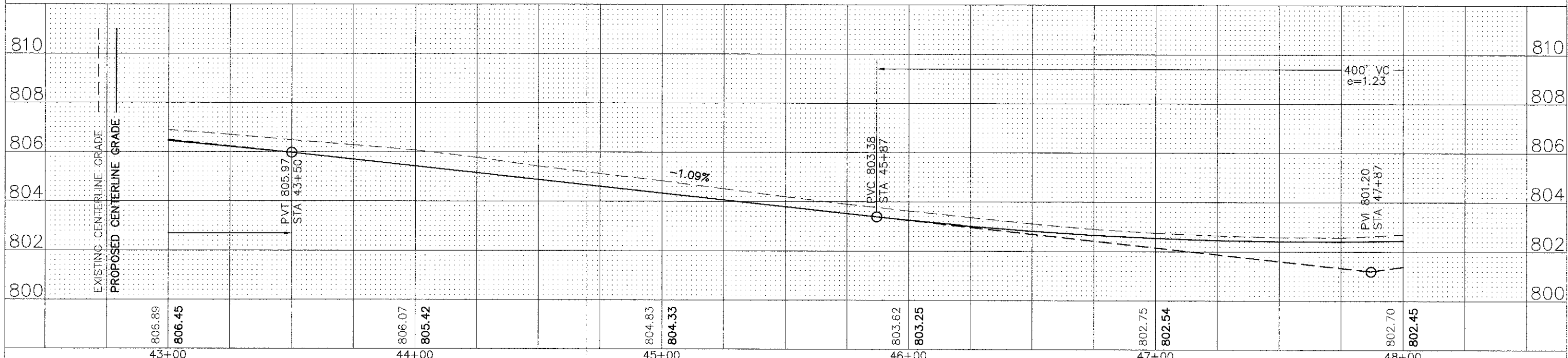

FILE NAME = Hassell Plan-Profile.dwg	DESIGNED -	REVISED -	STATE OF ILLINOIS DEPARTMENT OF TRANSPORTATION	Hassell Road STP Project Plan and Profile		F.A.U. RTE.	SECTION	COUNTY	TOTAL SHEET SHEETS NO.
	DRAWN -	REVISED -		SCALE: 1" = 20'	SHEET NO. 8 OF 16 SHEETS	1100	11-00087-00-FP	Cook	164 22
	CHECKED -	REVISED -		STA. 43+00 TO STA 48+00		CONTRACT NO. 63770			
	DATE -	REVISED -		ILLINOIS FED. AID PROJECT CMM 9003(757)					

PLAN	DATE	BY
REVISED		
ALIGNED		
CHECKED		
NO.		

PROFILE	DATE	BY
REVISED		
GRADES CHECKED		
NO.		

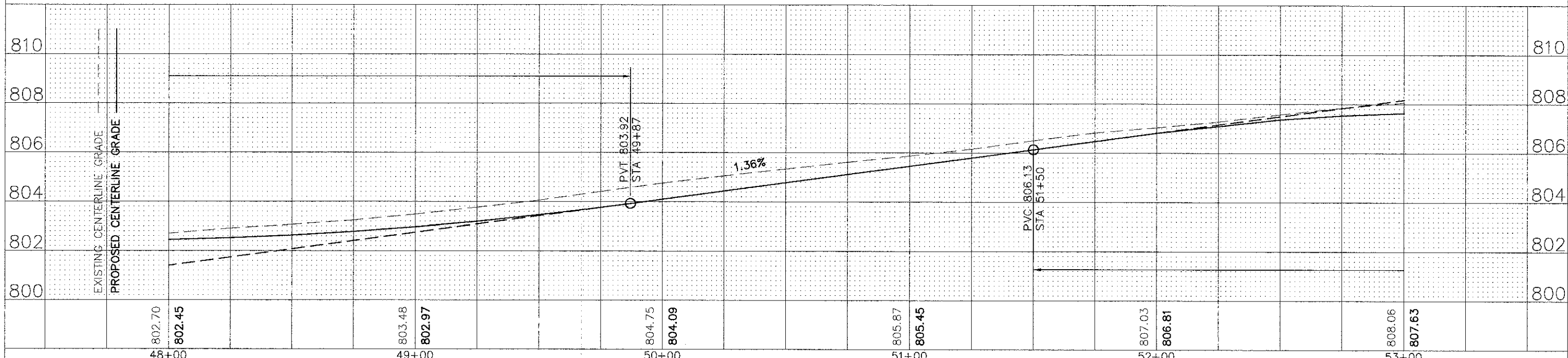
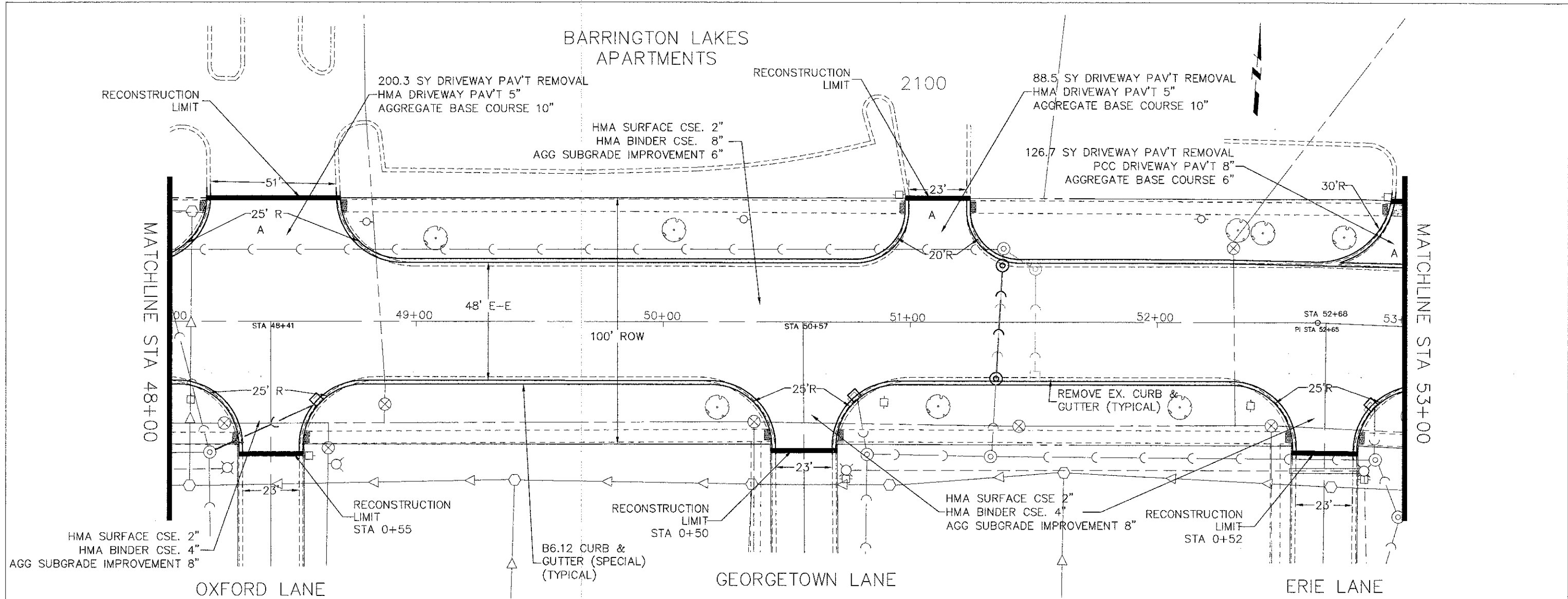

FILE NAME = Hassell Plan-Profile.dwg	DESIGNED -	REVISIONS -	STATE OF ILLINOIS DEPARTMENT OF TRANSPORTATION	Hassell Road STP Project Plan and Profile	F.A.U. R.T.E. 1100	SECTION 11-00087-00-FP	COUNTY Cook	TOTAL SHEETS 164	SHEET NO. 23	CONTRACT NO. 63770	ILLINOIS FED. AID PROJECT CMM 9003(757)
--------------------------------------	------------	-------------	---	--	--------------------	------------------------	-------------	------------------	--------------	--------------------	---

SCALE: 1" = 20' SHEET NO. 9 OF 16 SHEETS STA. 48+00 TO STA 53+00

STA 57+50-STA 63+35
 SOILS INDICATED ELEVATED
 pH VALUES ABOVE MAXIMUM
 ALLOWABLE CONCENTRATIONS.
 ALL SOILS REMOVED FROM SITE
 TO BE TREATED AS AND PAID FOR
 AS NON-SPECIAL WASTE DISPOSAL.

PLANNING
 REVISIONS
 DATE
 BY
 NO. 1
 NAME
 NO. 2
 NAME
 NO. 3
 NAME

PROFILE
 REVISIONS
 DATE
 BY
 NO. 1
 NAME
 NO. 2
 NAME
 NO. 3
 NAME

MATCHLINE STA 53+00

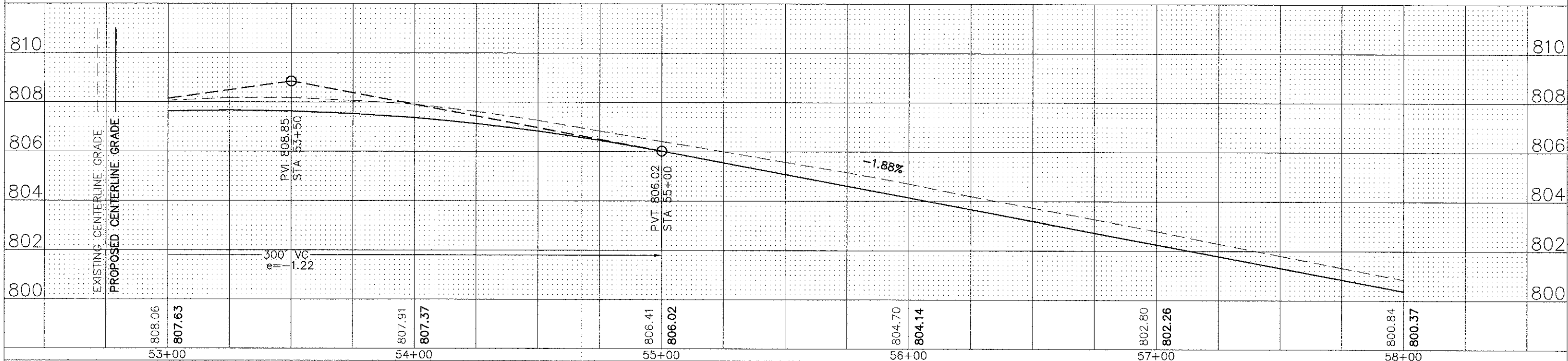
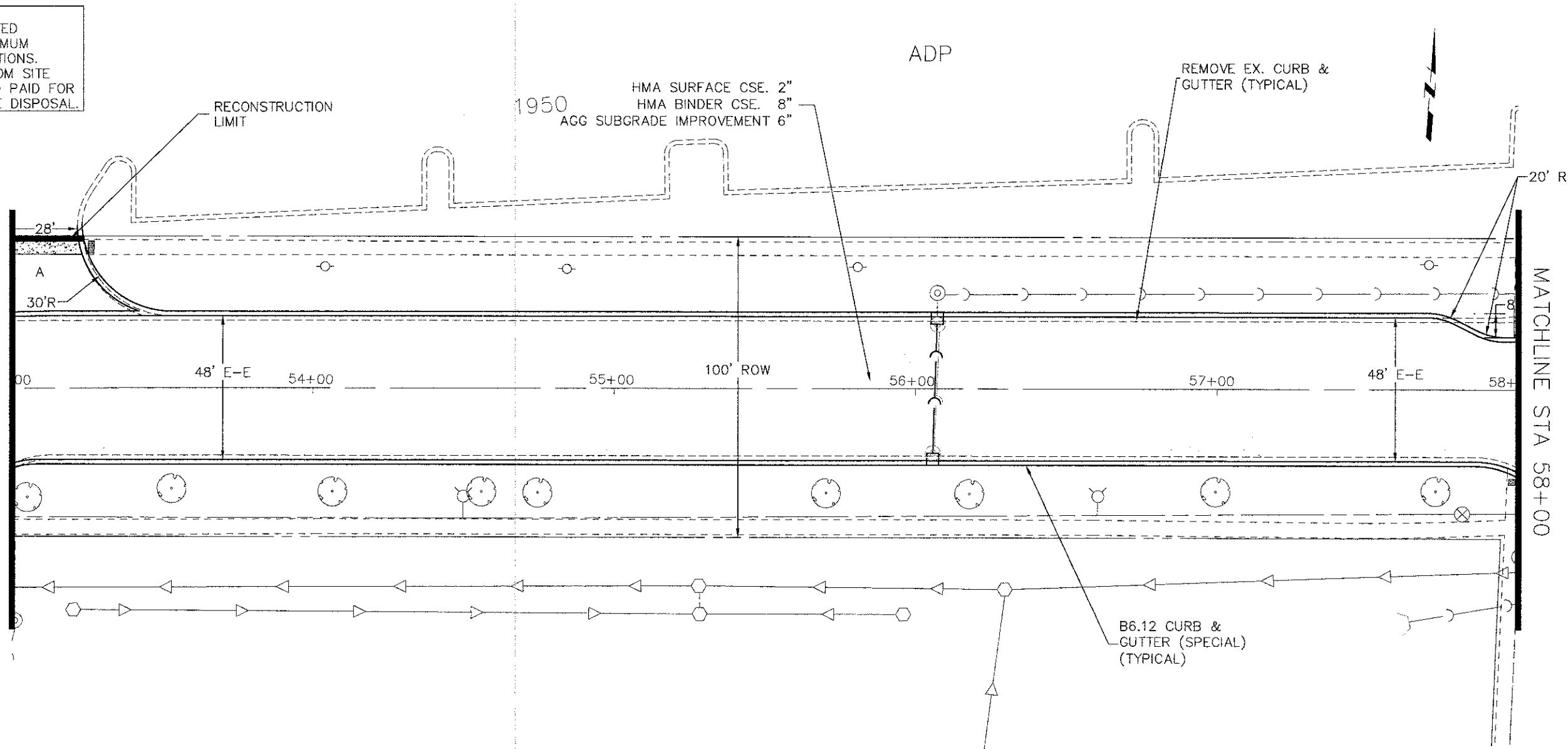

FILE NAME =
 Hassell Plan-Profile.dwg

DESIGNED -
 DRAWN -
 CHECKED -
 DATE -

STATE OF ILLINOIS
 DEPARTMENT OF TRANSPORTATION

Hassell Road STP Project
 Plan and Profile
 SCALE: 1" = 20'
 SHEET NO. 10 OF 16 SHEETS
 STA. 53+00 TO STA 58+00

F.A.U. RTE.	SECTION	COUNTY	TOTAL SHEETS	SHEET NO.
1100	11-00087-00-FP	Cook	164	24
CONTRACT NO. 63770			ILLINOIS FED. AID PROJECT CMM 9003(757)	

PLAN	DATE	BY
REVISED		
PLOTTED		
NOTE BOOK		
NO.		

PROFILE	DATE	BY
REVISED		
PLOTTED		
NOTE BOOK		
NO.		

STA 57+50-STA 63+35
SOILS INDICATED ELEVATED
pH VALUES ABOVE MAXIMUM
ALLOWABLE CONCENTRATIONS.
ALL SOILS REMOVED FROM SITE
TO BE TREATED AS AND PAID FOR
AS NON-SPECIAL WASTE DISPOSAL.

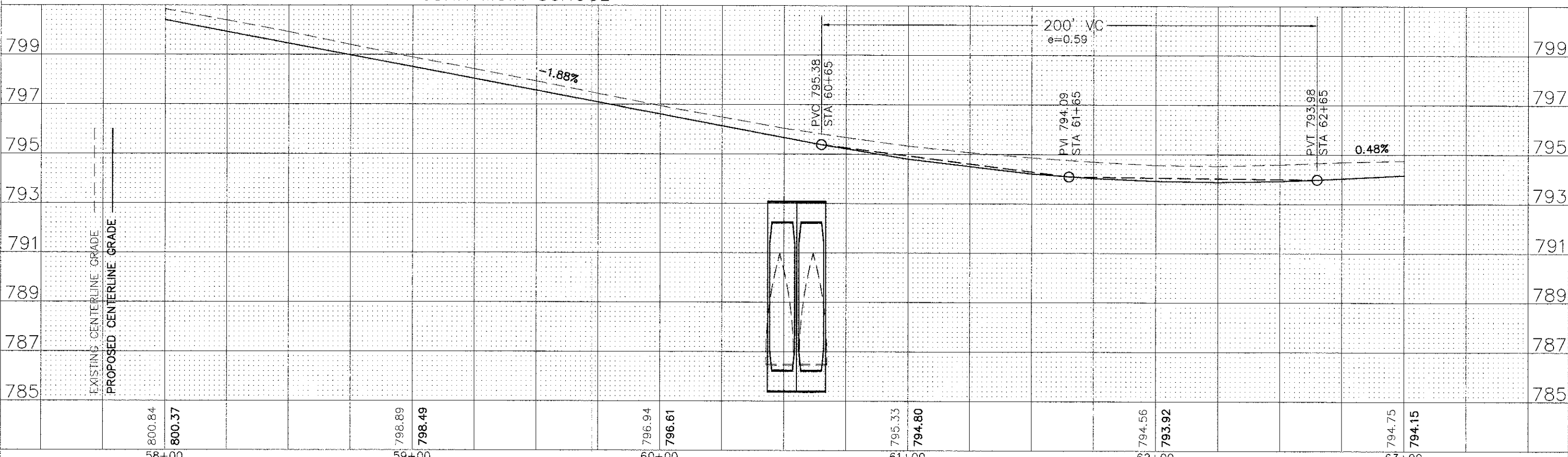
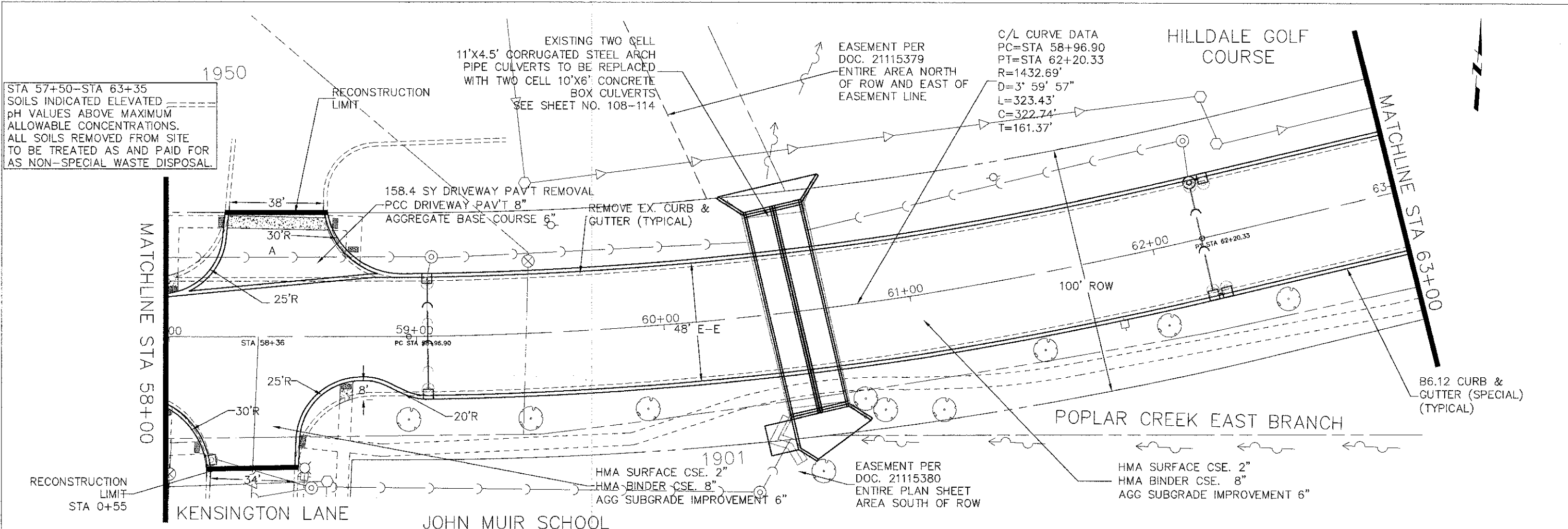

FILE NAME = Hassell Plan-Profile.dwg	DESIGNED -	REVISED -	STATE OF ILLINOIS DEPARTMENT OF TRANSPORTATION	Hassell Road STP Project Plan and Profile		F.A.U. RTE.	SECTION	COUNTY	TOTAL SHEETS	SHEET NO.	
	DRAWN -	REVISED -		SCALE: 1" = 20'	SHEET NO. 11 OF 16 SHEETS	STA. 58+00 TO STA 63+00	1100	11-00087-00-FP	Cook	164	25
	CHECKED -	REVISED -									
	DATE -	REVISED -									

ILLINOIS FED. AID PROJECT CMM 9003(757)

STA 57+50-STA 63+35
 SOILS INDICATED ELEVATED
 pH VALUES ABOVE MAXIMUM
 ALLOWABLE CONCENTRATIONS.
 ALL SOILS REMOVED FROM SITE
 TO BE TREATED AS AND PAID FOR
 AS NON-SPECIAL WASTE DISPOSAL.

HILLDALE GOLF COURSE

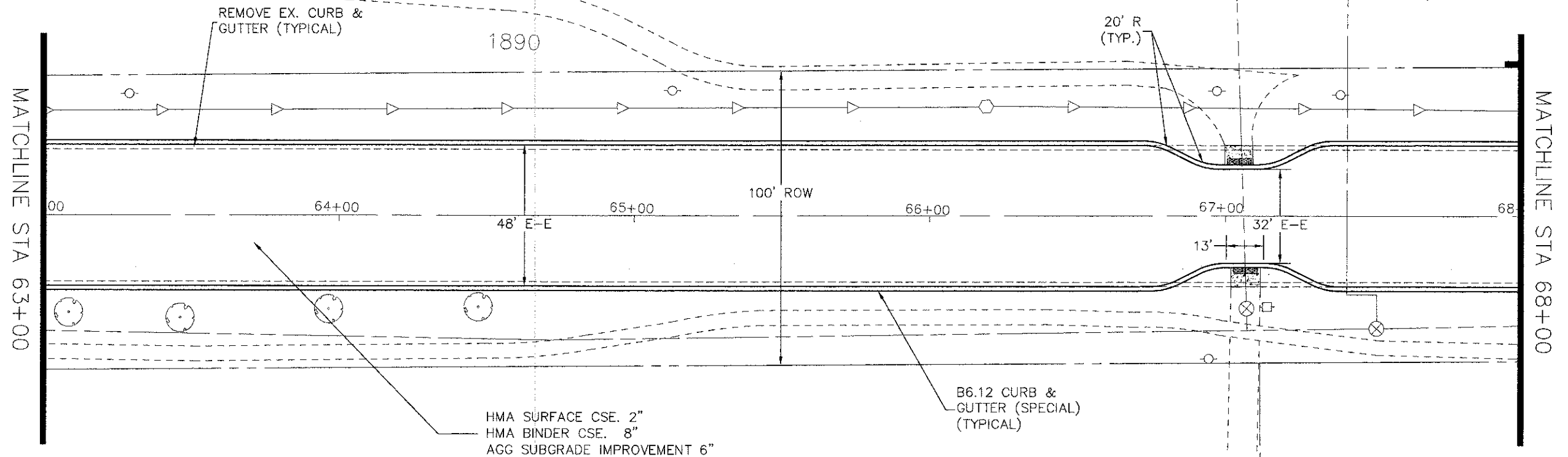

HILLDALE GOLF COURSE

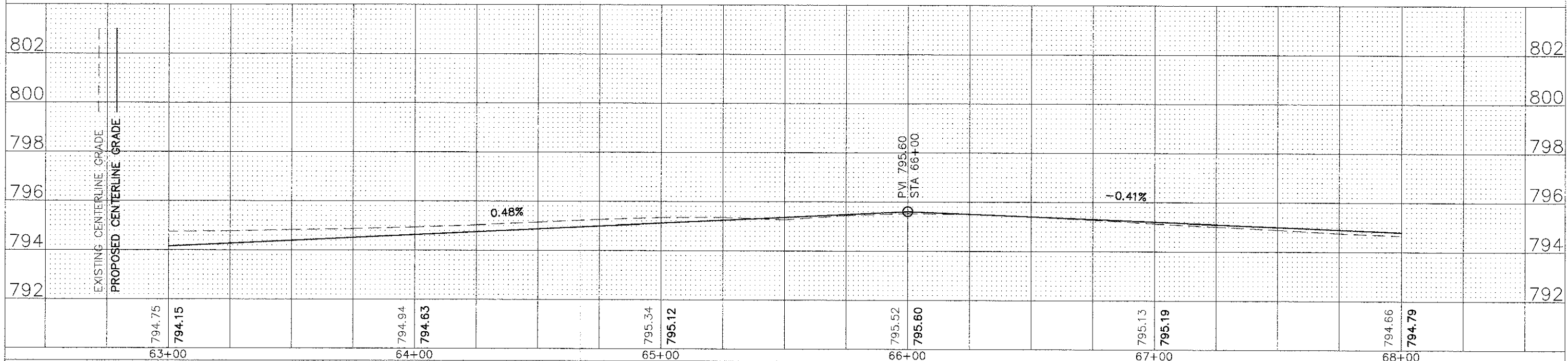

PLAN

DATE	BY

NOTE: BOOK ALIGNMENT CHECKED BY: _____
 NO. _____
 SAMPLE NAME _____

PROFILE

DATE	BY

NOTE: BOOK GRADES CHECKED BY: _____
 NO. _____
 STRUCTURE NOTATIONS CHKD _____

FILE NAME = Hassell Plan-Profile.dwg

DESIGNED -	REVISED -
DRAWN -	REVISED -
CHECKED -	REVISED -
DATE -	REVISED -

STATE OF ILLINOIS
 DEPARTMENT OF TRANSPORTATION

Hassell Road STP Project
 Plan and Profile

SCALE: 1" = 20' SHEET NO. 12 OF 16 SHEETS STA. 63+00 TO STA 68+00

F.A.U. RTE.	SECTION	COUNTY	TOTAL SHEETS	SHEET NO.
1100	11-00087-00-FP	Cook	164	26
CONTRACT NO. 63770			ILLINOIS FED. AID PROJECT CMM 9003(757)	

PLAN	DESIGNED	DATE	BY
	PLOTTED		
	ALIGNED		
	CHECKED		
	NO.		

PROFILE	DESIGNED	DATE	BY
	PLOTTED		
	GRADES		
	CHECKED		
	NO.		

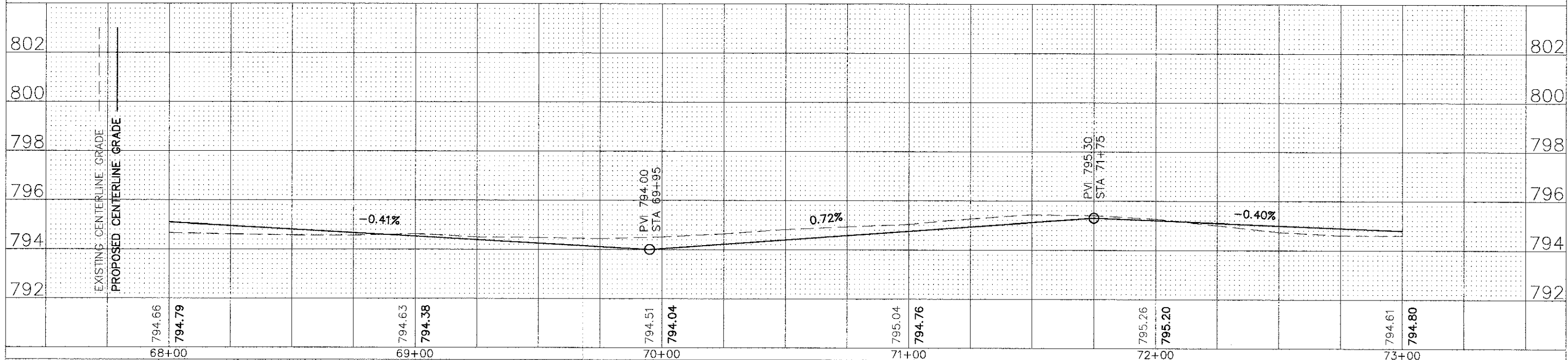
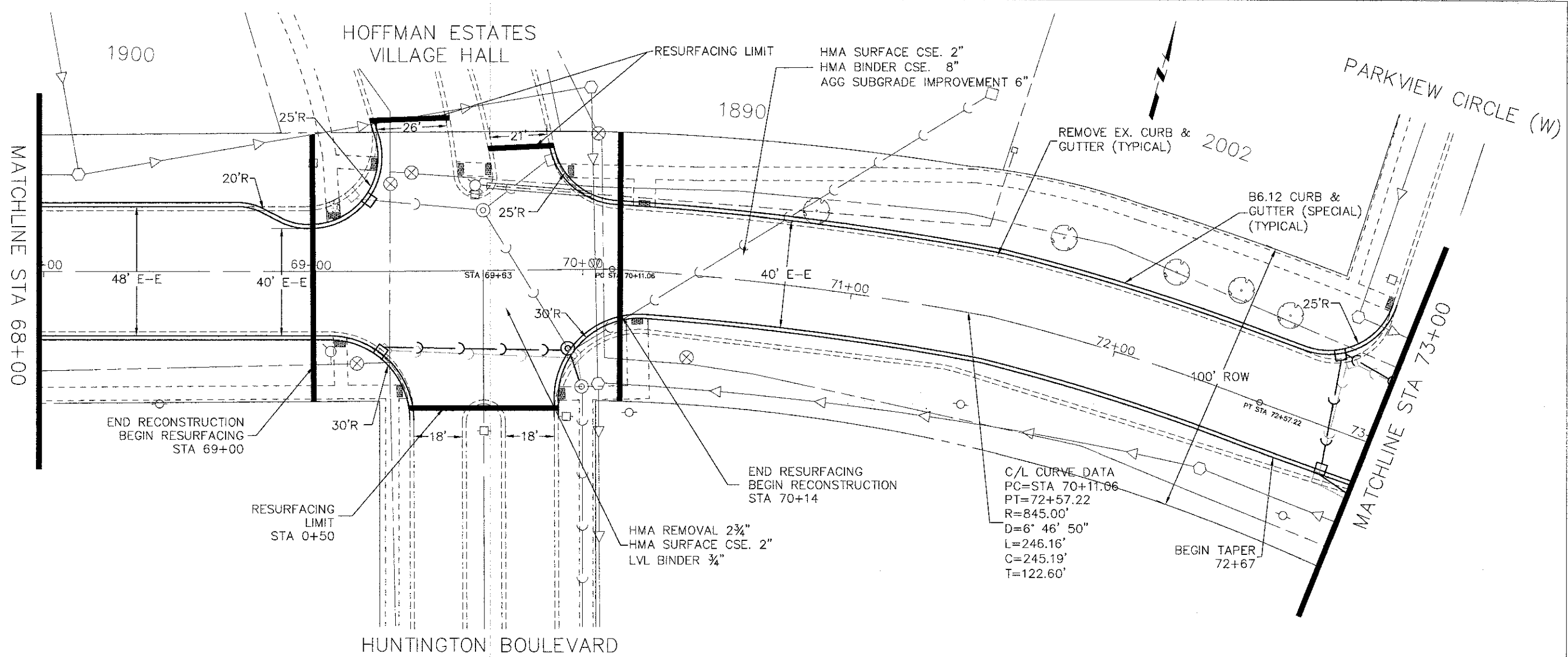

FILE NAME = Hassell Plan-Profile.dwg	DESIGNED -	REVISED -	STATE OF ILLINOIS DEPARTMENT OF TRANSPORTATION	Hassell Road STP Project		F.A.U. RTE.	SECTION	COUNTY	TOTAL SHEET	
	DRAWN -	REVISED -		SCALE: 1" = 20'	SHEET NO. 13 OF 16 SHEETS	STA. 68+00 TO STA 73+00	1100	11-00087-00-FP	Cook	164
	CHECKED -	REVISED -								27
	DATE -	REVISED -								CONTRACT NO. 63770
									ILLINOIS FED. AID PROJECT CMM 9003(757)	

PLAN	SURVEYED	DATE
	PLOTTED	
	CHECKED	
	BY	
	NO.	
	DATE	
	BY	
	NO.	
	DATE	

PROFILE	SURVEYED	DATE
	PLOTTED	
	CHECKED	
	BY	
	NO.	
	DATE	
	BY	
	NO.	
	DATE	

PARKVIEW CIRCLE (W)

PARKVIEW CIRCLE (E)

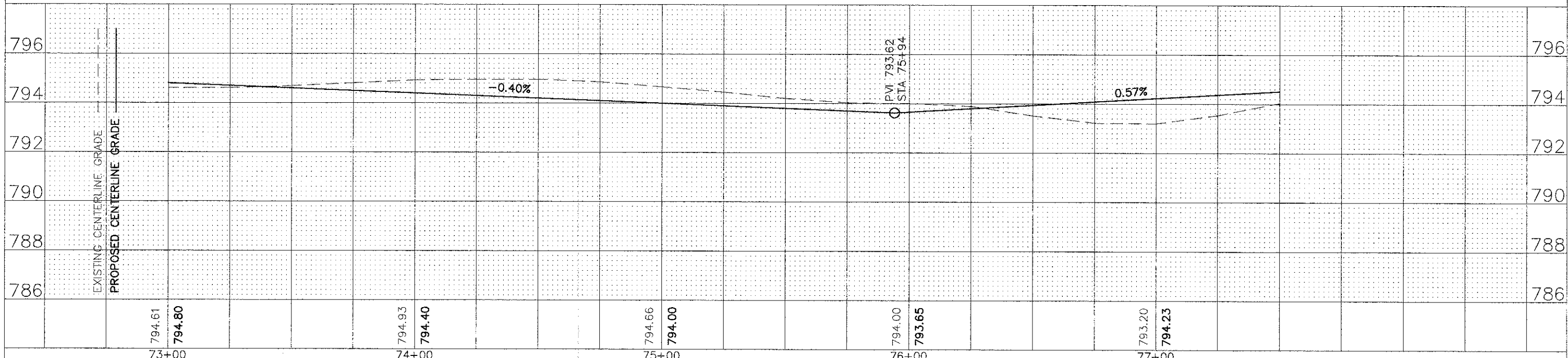
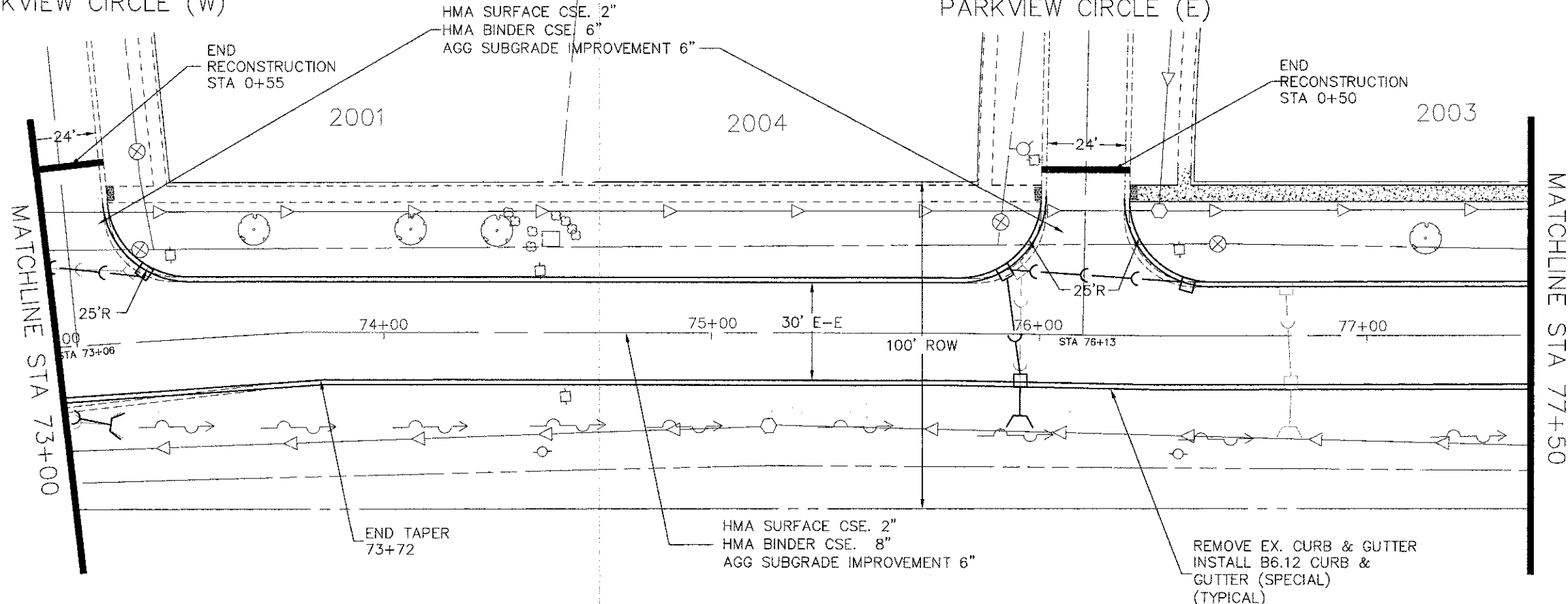

FILE NAME -	DESIGNED -	REVISED -	STATE OF ILLINOIS DEPARTMENT OF TRANSPORTATION	Hassell Road STP Project		F.A.U.	SECTION	COUNTY	TOTAL	SHEET	
Hassell Plan-Profile.dwg	DRAWN -	REVISED -		SCALE: 1" = 20'	SHEET NO. 14 OF 16 SHEETS	STA. 73+00 TO STA 77+50	1100	11-00087-00-FP	Cook	164	28
	CHECKED -	REVISED -									
	DATE -	REVISED -									
									CONTRACT. NO. 63770		
									ILLINOIS FED. AID PROJECT CMM 9003(757)		

PLAN	SURVEYED	DATE	BY
	ALIGNED		
	CHECKED		
	NO. OF PLYS CHECKED		
	DATE		
	NO.		

PROFILE	SURVEYED	DATE	BY
	GRADES CHECKED		
	BLM. NOTED		
	STRUCTURE NOTATIONS CHG		
	NO.		

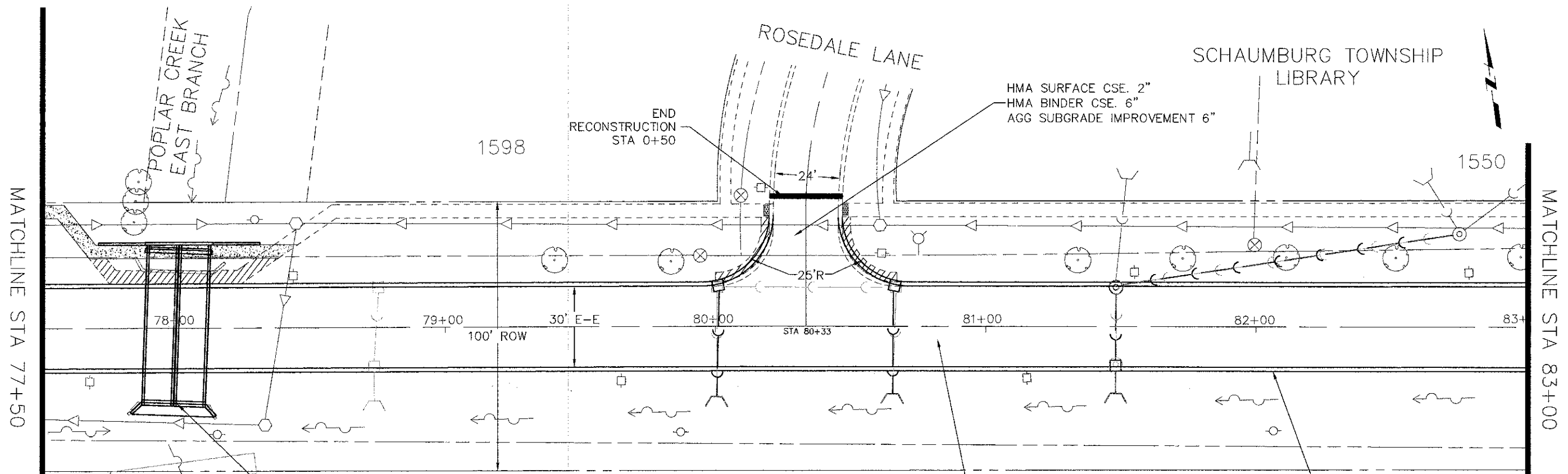

EXISTING TWO CELL
11'X4.5' CORRUGATED STEEL ARCH
PIPE CULVERTS TO BE REPLACED
WITH TWO CELL 10'X6' BOX CULVERTS
SEE SHEET NO. 115-121

HMA SURFACE CSE. 2"
HMA BINDER CSE. 8"
AGG SUBGRADE IMPROVEMENT 6"

REMOVE EX. CURB & GUTTER
INSTALL B6.12 CURB &
GUTTER (SPECIAL)
(TYPICAL)

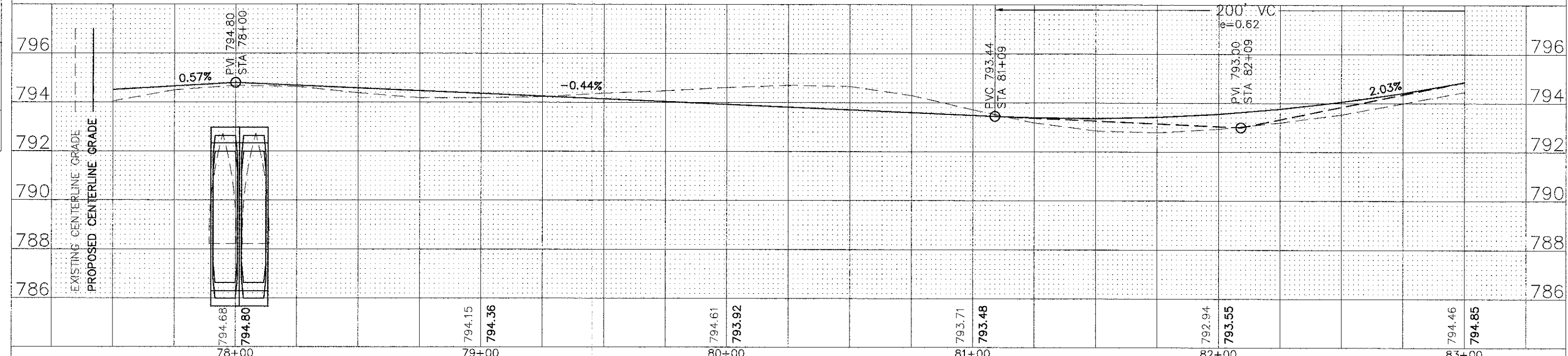

FILE NAME = Hassell Plan-Profile.dwg	DESIGNED - DRAWN - CHECKED - DATE -	REVISED - REVISED - REVISED - REVISED -	STATE OF ILLINOIS DEPARTMENT OF TRANSPORTATION	Hassell Road STP Project Plan and Profile	F.A.U. RTE. 1100	SECTION 11-00087-00-FP	COUNTY Cook	TOTAL SHEETS 164	SHEET NO. 29	CONTRACT NO. 63770	ILLINOIS FED. AID PROJECT CMM 9003(757)
---	--	--	---	--	------------------------	---------------------------	----------------	---------------------	-----------------	--------------------	---

SCALE: 1" = 20' SHEET NO. 15 OF 16 SHEETS STA. 77+50 TO STA 83+00

PLAN	SURVEYED	DATE
	PLOTTED	BY
	ALIGNED	CHECKED
	NOTE BOOK	NO.
	DATE	

PROFILE	SURVEYED	DATE
	PLOTTED	BY
	GRADES CHECKED	CHECKED
	STRUCTURE NOTATIONS OK'D	NO.
	DATE	

MATCHLINE STA 83+00

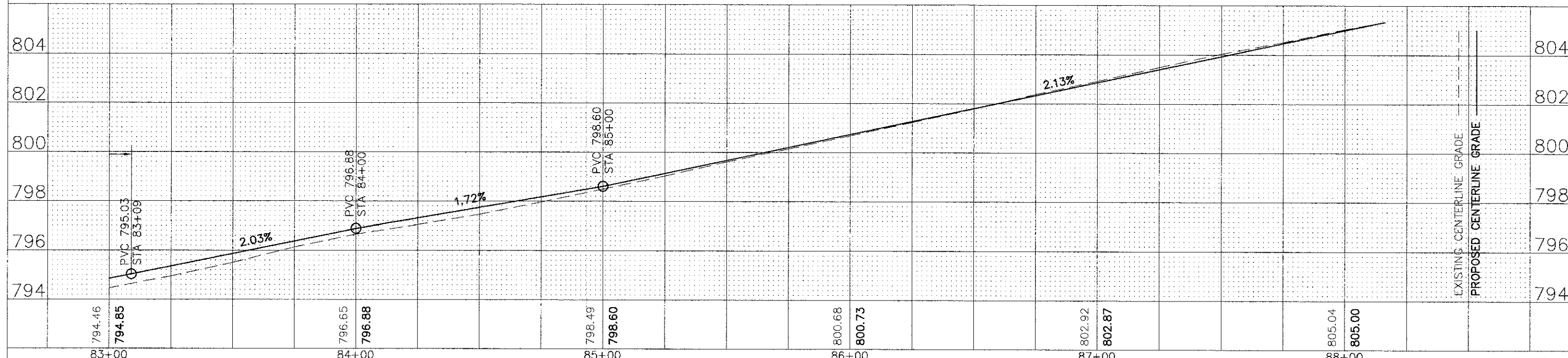
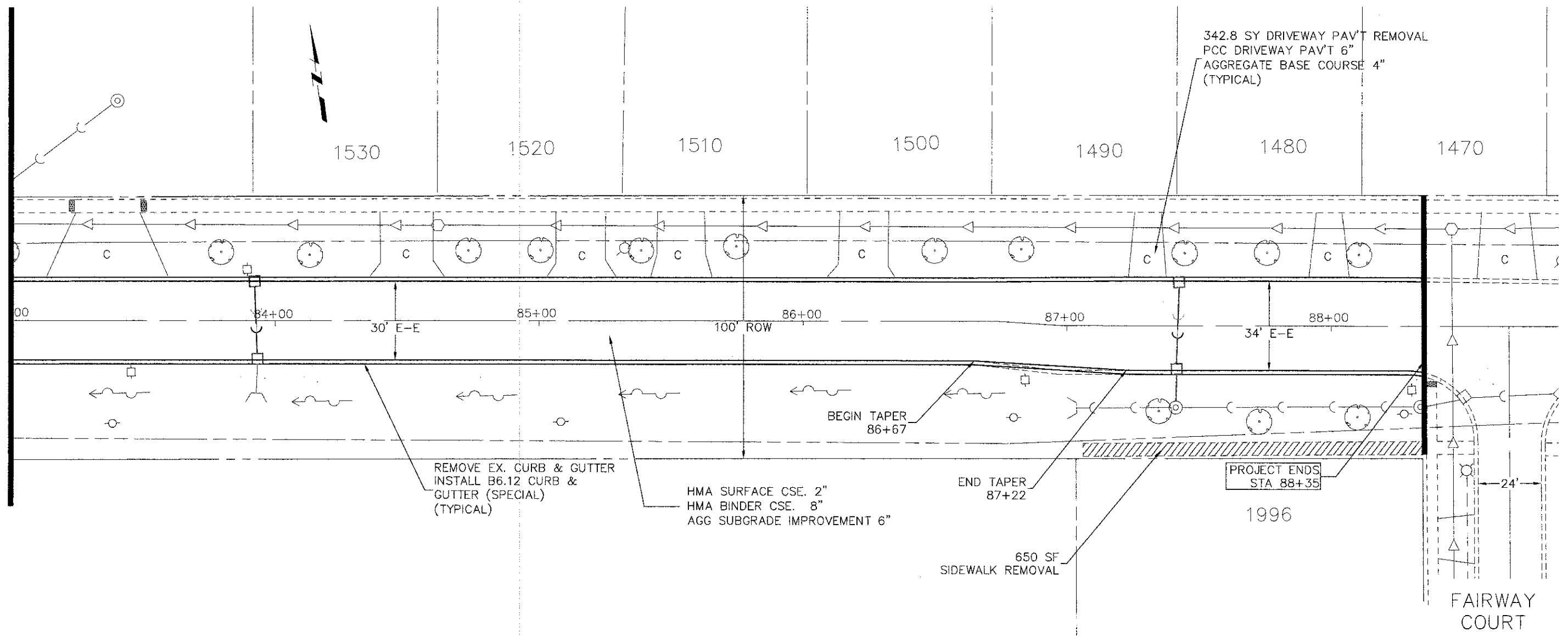

FILE NAME =	DESIGNED -	REVISED -
Hassell Plan-Profile.dwg	DRAWN -	REVISED -
	CHECKED -	REVISED -
	DATE -	REVISED -

**STATE OF ILLINOIS
DEPARTMENT OF TRANSPORTATION**

Hassell Road STP Project
Plan and Profile
SCALE: 1" = 20' SHEET NO. 16 OF 16 SHEETS STA. 83+00 TO STA 89+00

F.A.U. RTE.	SECTION	COUNTY	TOTAL SHEETS	SHEET NO.
1100	11-00087-00-FP	Cook	164	30
CONTRACT NO. 63770			ILLINOIS FED. AID PROJECT CMM 9003(757)	

STAGE 1
TYPICAL SECTIONS

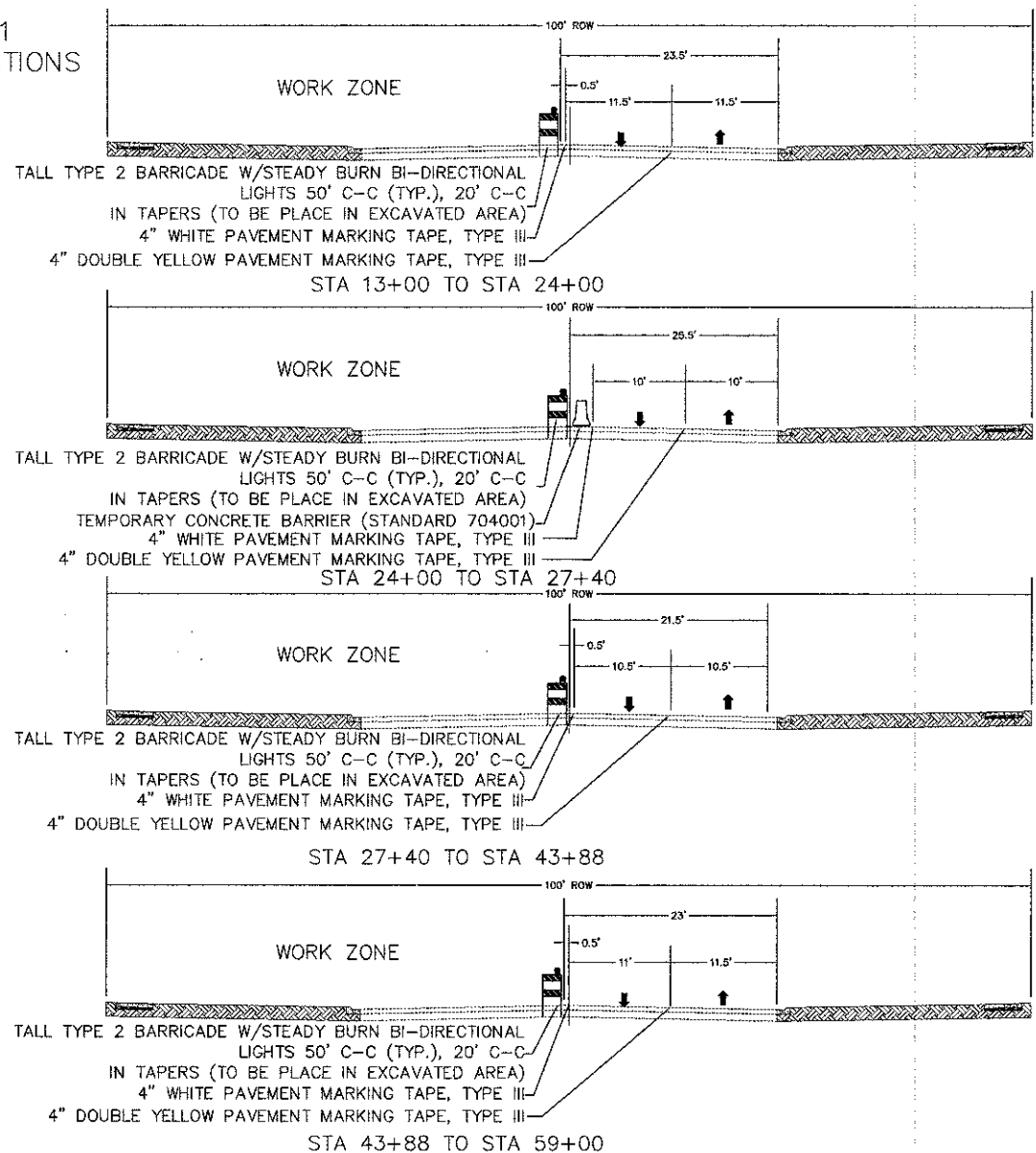

1. ESTABLISH TWO-WAY, TWO LANE TRAFFIC FLOW ALONG THE SOUTH SIDE OF HASSELL ROAD AS SHOWN ON THE PLANS.
2. CLOSE OUTER LEFT TURN LANE ON SOUTHBOUND BARRINGTON ROAD ACCORDING TO DISTRICT DETAIL TC-14.
3. REMOVE THE EXISTING PAVEMENT AND CURB AND GUTTER ALONG THE NORTH SIDE OF HASSELL ROAD.
4. CONSTRUCT NORTH SIDE STORM SEWER LATERALS AND DRAINAGE STRUCTURES. PROVIDE TEMPORARY CONNECTIONS TO EXISTING SEWER.
5. CONSTRUCT COMBINATION CONCRETE CURB AND GUTTER AND WESTBOUND PAVEMENT AS SHOWN ON THE PLANS.
6. CONSTRUCT PAVEMENT AT AREAS OF CURB BUMP-OUTS, AS SHOWN ON THE PLANS. COMPLETE FINAL COMBINATION CONCRETE CURB AND GUTTER AND WESTBOUND PAVEMENT AFTER COMPLETION OF STAGE 2.
7. COMPLETE PERMANENT LANDSCAPE RESTORATION.

STAGE 2
TYPICAL SECTIONS

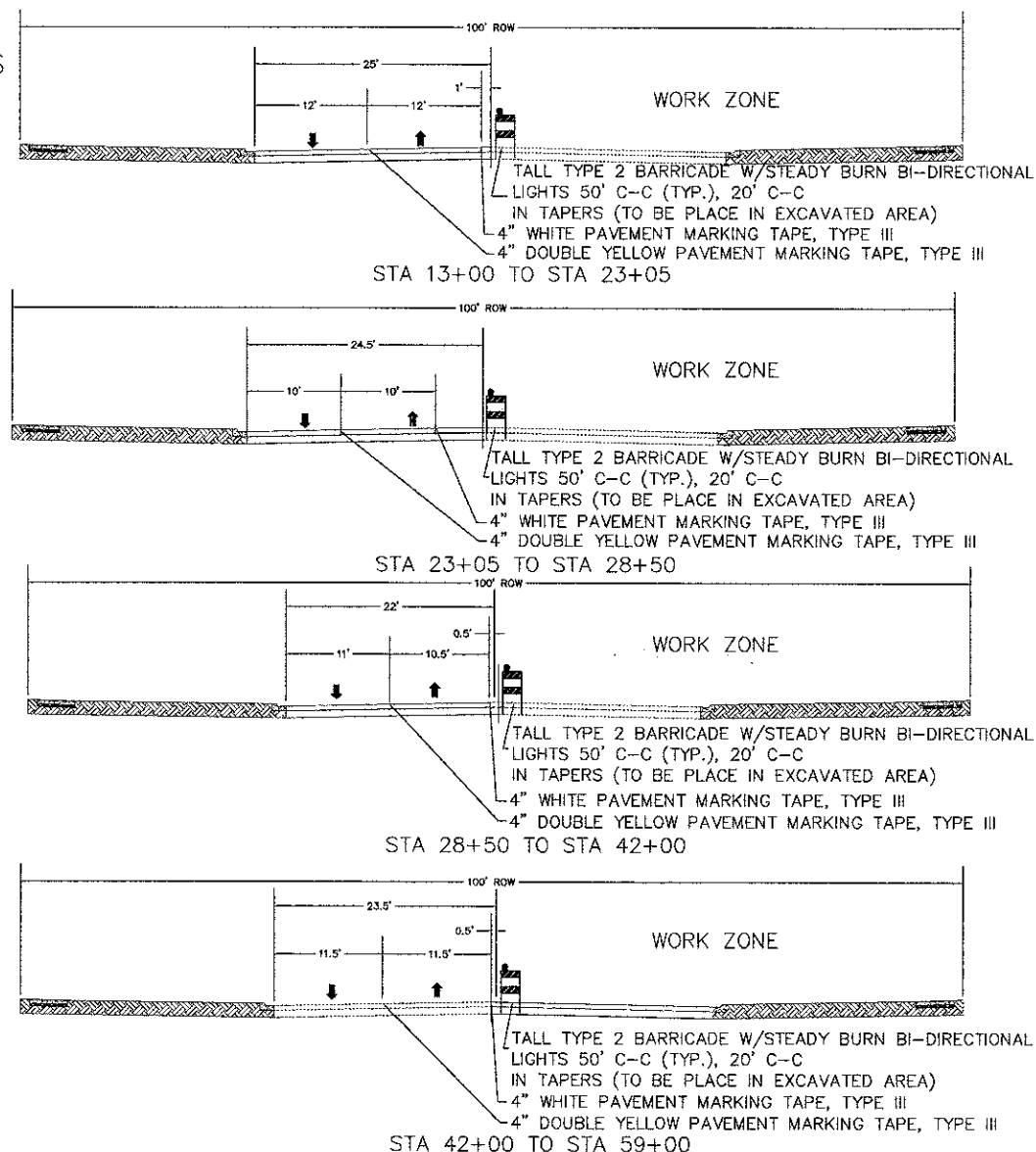

1. ESTABLISH TWO-WAY, TWO LANE TRAFFIC FLOW ALONG THE NORTH SIDE OF HASSELL ROAD AS SHOWN ON THE PLANS.
2. CLOSE OUTER LEFT TURN LANE ON SOUTHBOUND BARRINGTON ROAD ACCORDING TO DISTRICT DETAIL TC-14.
3. REMOVE THE EXISTING PAVEMENT AND CURB AND GUTTER ALONG THE SOUTH SIDE OF HASSELL ROAD.
4. CONSTRUCT SIDE SIDE STORM SEWER LATERALS AND DRAINAGE STRUCTURES.
5. CONSTRUCT COMBINATION CONCRETE CURB AND GUTTER AND EASTBOUND PAVEMENT AS SHOWN ON THE PLANS.
6. REMOVE TEMPORARY STRIPING ON NORTH SIDE OF PAVEMENT. RESTORE TWO-WAY FOUR LANE TRAFFIC TO HASSELL ROAD FROM STATION 13+00 TO STATION 59+00 WITH TEMPORARY PAVEMENT MARKING - LINE, 4".
7. REMOVE PAVEMENT AND CONSTRUCT CURB BUMP-OUT AREAS ON WESTBOUND PAVEMENT.
8. COMPLETE PERMANENT LANDSCAPE RESTORATION.

GENERAL NOTES:

1. STAGING PROCEDURES PRESENTED ARE THE SUGGESTED SEQUENCE OF OPERATIONS. THE CONTRACTOR MAY SUBMIT AN ALTERNATIVE STAGING PROPOSAL TO THE ENGINEER FOR APPROVAL. THE CONTRACTOR SHALL NOT BE ENTITLED TO ADDITIONAL COMPENSATION FOR CHANGE IN STAGING.
2. STAGE 3 SHALL CONSIST OF WORK FROM STATION 59+00 TO STATION 73+50. STAGE 4 SHALL CONSIST OF WORK FROM STATION 73+50 TO STATION 88+50. DETOUR ROUTES, AS SHOWN IN THE PLANS, SHALL BE IN PLACE DURING THOSE STAGES OF WORK.
3. THE CONTRACTOR SHALL MAINTAIN A MINIMUM ONE 10 FOOT LANE IN EACH DIRECTION FOR TWO-WAY, TWO LANE TRAFFIC. INGRESS AND EGRESS OF THE SIDE STREETS AND DRIVEWAYS SHALL BE MAINTAINED AT ALL TIMES.
4. THE CONTRACTOR SHALL MAINTAIN TRAFFIC IN ACCORDANCE WITH THE SPECIAL PROVISIONS, DETAILS, STATE STANDARDS, STANDARD SPECIFICATIONS AND AS DIRECTED BY THE ENGINEER. ALL COSTS ASSOCIATED WITH SHALL BE INCLUDED IN THE COST FOR TRAFFIC CONTROL AND PROTECTION (SPECIAL).
5. THE ENGINEER SHALL BE INFORMED 72 HOURS IN ADVANCE OF ANY CHANGE IN CONSTRUCTION STAGING.
6. THE CONTRACTOR SHALL BE REQUIRED TO REMOVE ALL EXISTING PAVEMENT MARKINGS WHICH CONFLICT WITH THE DESIGNATED TRAFFIC CONTROL PLAN. THIS WORK SHALL BE PAID FOR AS PAVEMENT MARKING REMOVAL OR WORK ZONE PAVEMENT MARKING REMOVAL.
7. ACCESS TO ALL BUSINESSES MUST BE MAINTAINED AT ALL TIMES. DRIVEWAY CONSTRUCTION WORK SHALL BE STAGED TO ALLOW ACCESS. ENTRANCE SIGNS SHALL BE PLACED AT ALL DRIVEWAY ENTRANCES, AS SPECIFIED BY THE ENGINEER. DRIVEWAY ENTRANCE SIGNS SHALL BE IN ACCORDANCE WITH THE DRIVEWAY ENTRANCE SIGNAGE DETAIL.
8. THE FURNISHING, INSTALLING, AND RELOCATION OF ALL TRAFFIC SIGNS SHALL BE IN ACCORDANCE WITH THE MANUAL ON UNIFORM TRAFFIC CONTROL DEVICES AND THE STANDARD SPECIFICATIONS. ALL CONFLICTING TRAFFIC SIGNS SHALL BE COVERED AS DIRECTED BY THE ENGINEER. THE WORK SHALL BE INCLUDED IN THE COST OF TRAFFIC CONTROL AND PROTECTION WHEN NOT SPECIFICALLY SHOWN ON THE STRIPING AND SIGNAGE PLANS.
9. THE CONTRACTOR SHALL NOT MOUNT TEMPORARY SIGNS ON EXISTING SIGNS.
10. THE CONTRACTOR SHALL BE RESPONSIBLE FOR ENSURING THAT ALL BARRICADES, SIGNS, LIGHTS, AND OTHER DEVICES INSTALLED ARE IN PLACE AND OPERATION 24 HOURS EACH DAY INCLUDING SUNDAYS AND HOLIDAYS DURING THE TIME THE TRAFFIC CONTROL PLAN IS IN EFFECT.
11. THE DETOUR PLAN SHALL BE IN PLACE FOR THE DURATION OF STAGE 3 AND STAGE 4 CONSTRUCTION ONLY.
12. ANY TEMPORARY PIPE CONNECTIONS NEEDED FOR STAGING OF STORM SEWER IMPROVEMENTS SHALL BE CONSIDERED INCLUDED IN THE APPLICABLE PAY ITEMS FOR STORM SEWER
13. DURING STAGE 3, ACCESS TO THE HOFFMAN ESTATES VILLAGE HALL SHALL BE MAINTAINED AT ALL TIMES VIA HUNTINGTON BOULEVARD.
14. DURING STAGE 3 AND STAGE 4, ONE ACCESS POINT TO PARKVIEW CIRCLE MUST BE MAINTAINED AT ALL TIMES.

PLAN	DESIGNED	DATE	BY
	NOTED		
	CHECKED		
	APPROVED		
NOTE BOOK ALIGNMENT CHECKED			
NOTE BOOK GRADES CHECKED			
NOTE BOOK STATIONING CHECKED			
NOTE BOOK PROFILE CHECKED			
NOTE BOOK PLAN CHECKED			
NOTE BOOK SPECIFICATIONS CHECKED			
NOTE BOOK MATERIALS CHECKED			
NOTE BOOK CONTRACT CHECKED			
NOTE BOOK GENERAL CHECKED			
NOTE BOOK FINISH CHECKED			
NOTE BOOK AS-BUILT CHECKED			
NOTE BOOK FINAL CHECKED			
NOTE BOOK TOTAL CHECKED			
NOTE BOOK NO.			

PROFILE	DESIGNED	DATE	BY
	NOTED		
	CHECKED		
	APPROVED		
NOTE BOOK ALIGNMENT CHECKED			
NOTE BOOK GRADES CHECKED			
NOTE BOOK STATIONING CHECKED			
NOTE BOOK PROFILE CHECKED			
NOTE BOOK PLAN CHECKED			
NOTE BOOK SPECIFICATIONS CHECKED			
NOTE BOOK MATERIALS CHECKED			
NOTE BOOK CONTRACT CHECKED			
NOTE BOOK GENERAL CHECKED			
NOTE BOOK FINISH CHECKED			
NOTE BOOK AS-BUILT CHECKED			
NOTE BOOK FINAL CHECKED			
NOTE BOOK TOTAL CHECKED			
NOTE BOOK NO.			

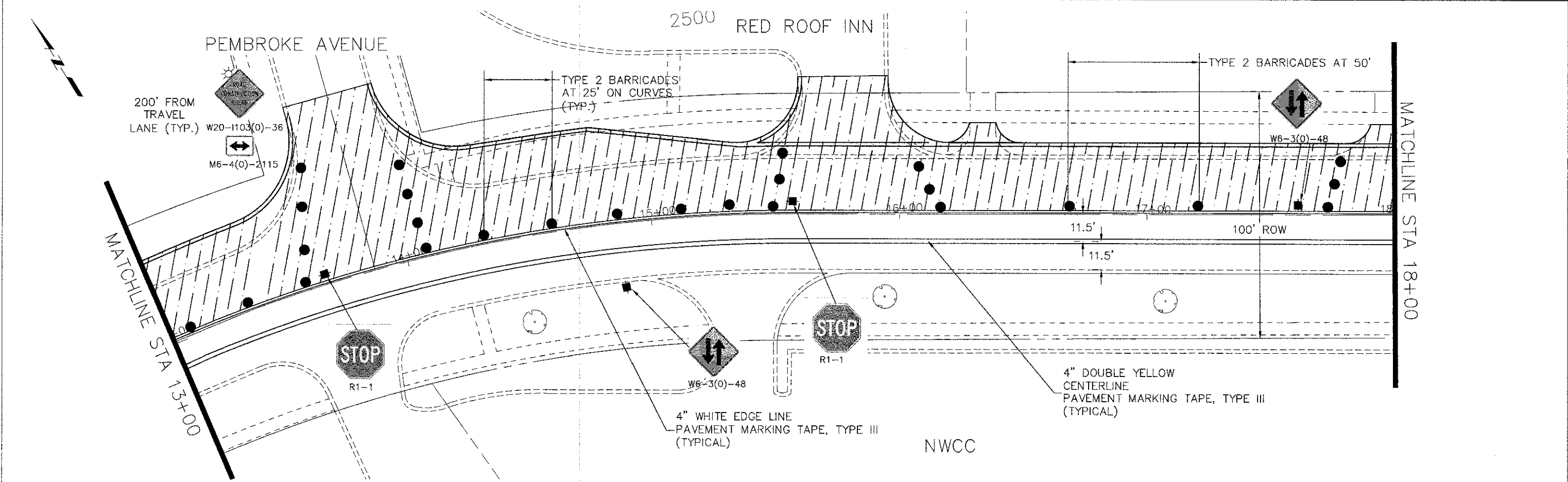
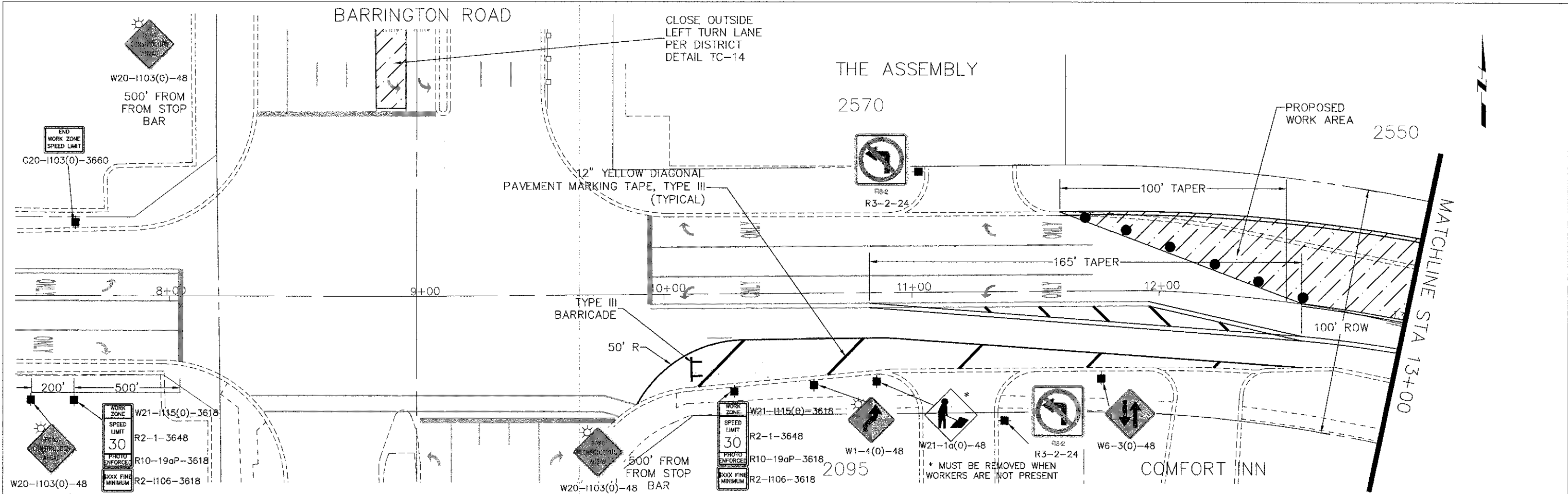

FILE NAME =	DESIGNED -	REVISED -
Hassell Plan-Profile.dwg	DRAWN -	REVISED -
	CHECKED -	REVISED -
	DATE -	REVISED -

**STATE OF ILLINOIS
DEPARTMENT OF TRANSPORTATION**

Hassell Road STP Project
Construction Staging 1

SCALE: 1" = 20' SHEET NO. 2 OF 18 SHEETS STA. 9+00 TO STA 18+00

F.A.U. RTE.	SECTION	COUNTY	TOTAL SHEETS
1100	11-00087-00-FP	Cook	164
CONTRACT NO. 63770			SHEETS NO. 32
ILLINOIS FED. AID PROJECT CMM 9003(757)			

PLAN	SURVEYED	DATE	BY
	PLOTTED		
	CHECKED		
	BY		
	NO. OF		
	DATE		
	BY		
	NO.		

PROFILE	SURVEYED	DATE	BY
	PLOTTED		
	CHECKED		
	BY		
	NO. OF		
	DATE		
	BY		
	NO.		

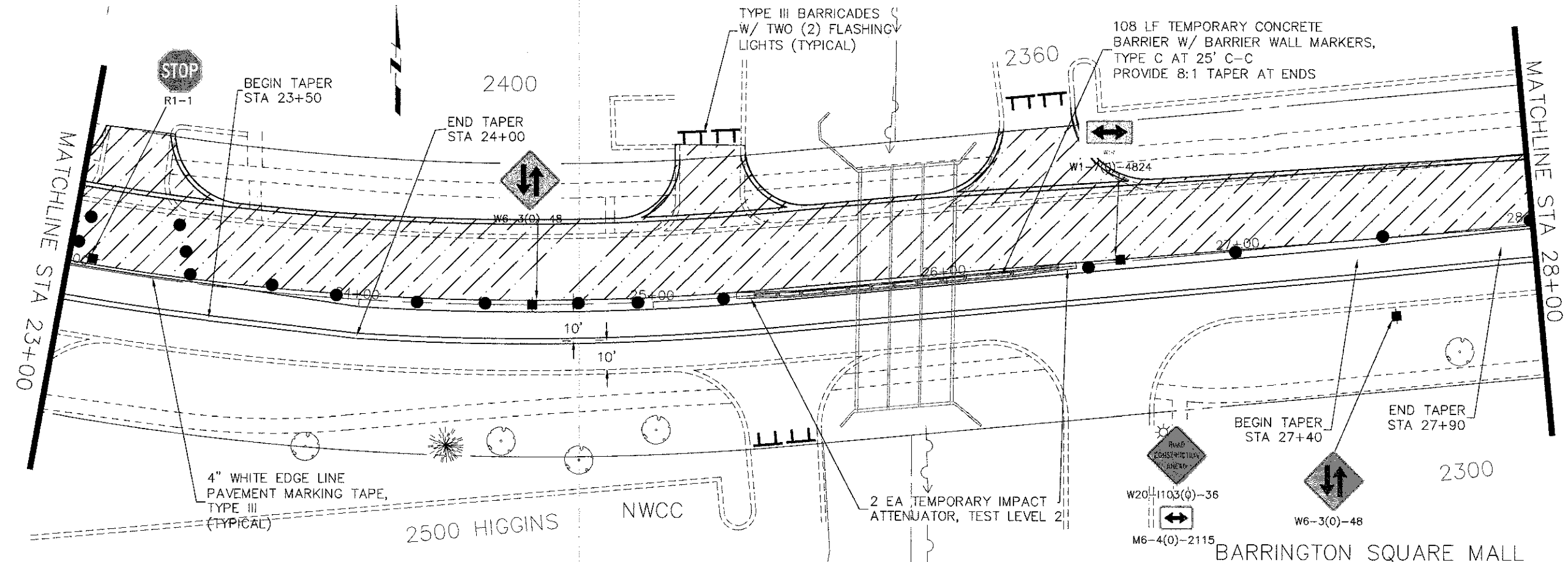
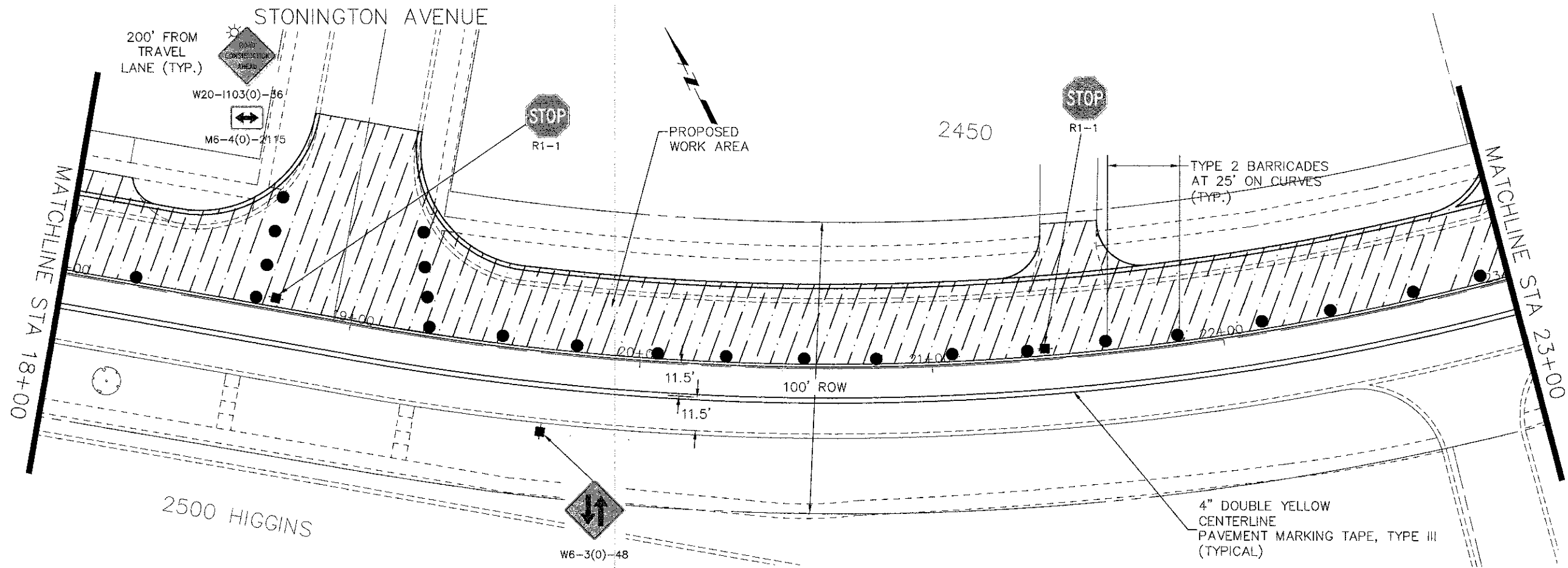

FILE NAME = Hassell Plan-Profile.dwg

DESIGNED -	REVISED -
DRAWN -	REVISED -
CHECKED -	REVISED -
DATE -	REVISED -

STATE OF ILLINOIS
DEPARTMENT OF TRANSPORTATION

Hassell Road STP Project
Construction Staging 1

SCALE: 1" = 20' SHEET NO. 3 OF 18 SHEETS STA. 18+00 TO STA 28+00

F.A.U. RTE.	SECTION	COUNTY	TOTAL SHEETS	SHEET NO.
1100	11-00087-00-FP	Cook	164	33
CONTRACT NO. 63770			ILLINOIS FED. AID PROJECT CMM 9003(757)	

PLAN	DESIGNED	BY	DATE
	PLOTTED		
	NOTE BOOK	ALIGNED	CHECKED
		DATE	
		NO.	

PROFILE	DESIGNED	BY	DATE
	PLOTTED		
	NOTE BOOK	GRADES	CHECKED
		STRUCTURE	NOTATION
		NO.	

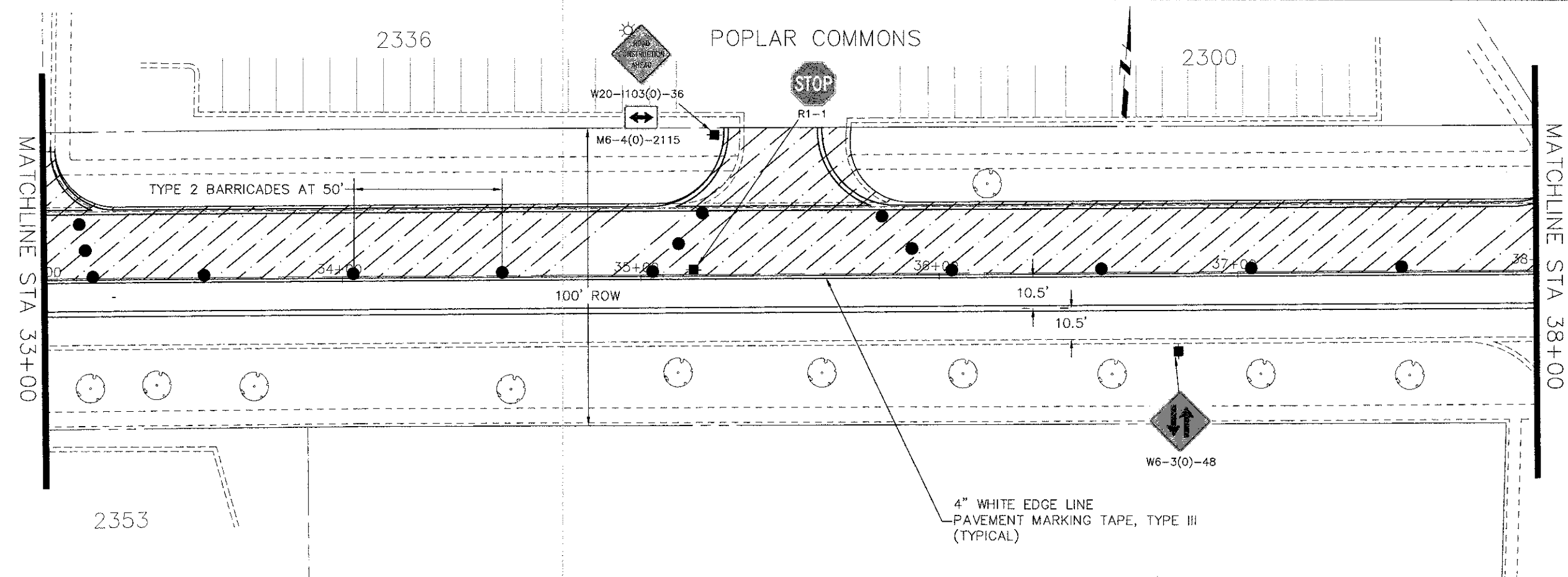
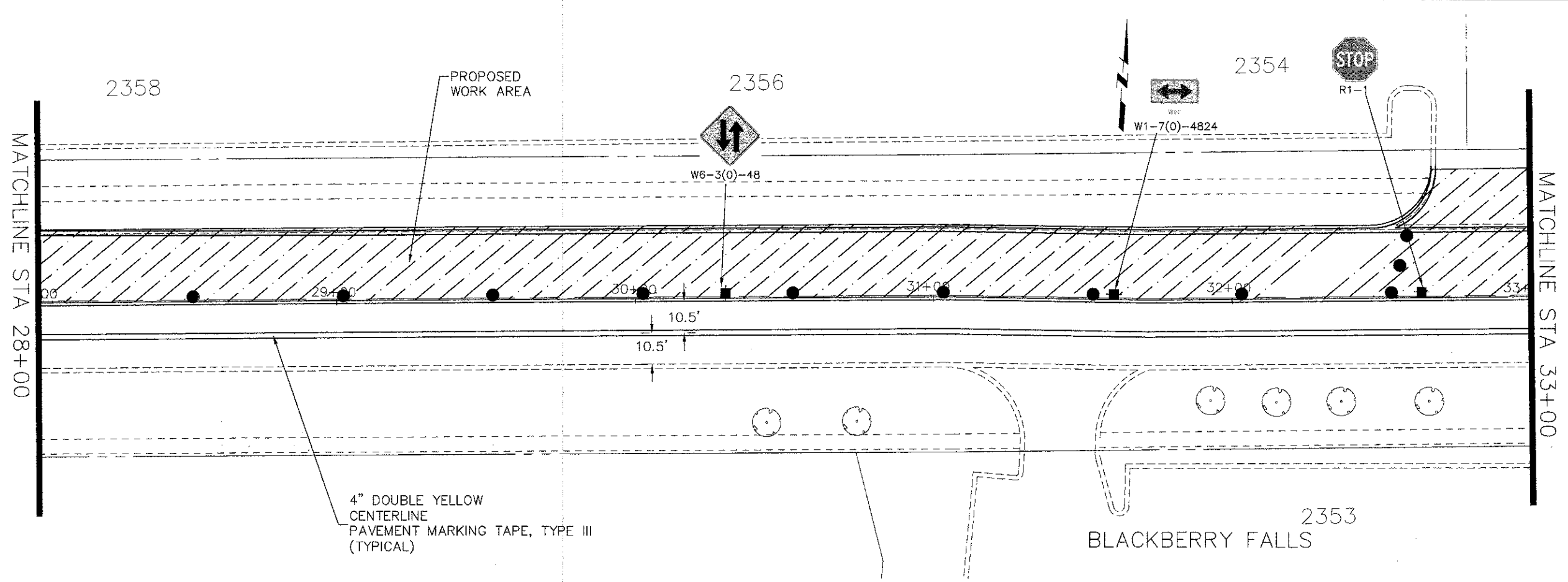

FILE NAME =
Hassell Plan-Profile.dwg

DESIGNED -	REVISED -
DRAWN -	REVISED -
CHECKED -	REVISED -
DATE -	REVISED -

**STATE OF ILLINOIS
DEPARTMENT OF TRANSPORTATION**

Hassell Road STP Project
Construction Staging 1
SCALE: 1" = 20' SHEET NO. 4 OF 18 SHEETS STA. 28+00 TO STA 38+00

F.A.U. RTE.	SECTION	COUNTY	TOTAL SHEETS	SHEET NO.
1100	11-00087-00-FP	Cook	164	34
CONTRACT NO. 63770				ILLINOIS FED. AID PROJECT OMM 9003(757)

PLAN	SURVEYED	DATE	BY
	PLOTTED		
	ALIGNED		
	CHECKED		
	NO.		

PROFILE	SURVEYED	DATE	BY
	PLOTTED		
	GRADES		
	CHECKED		
	NO.		

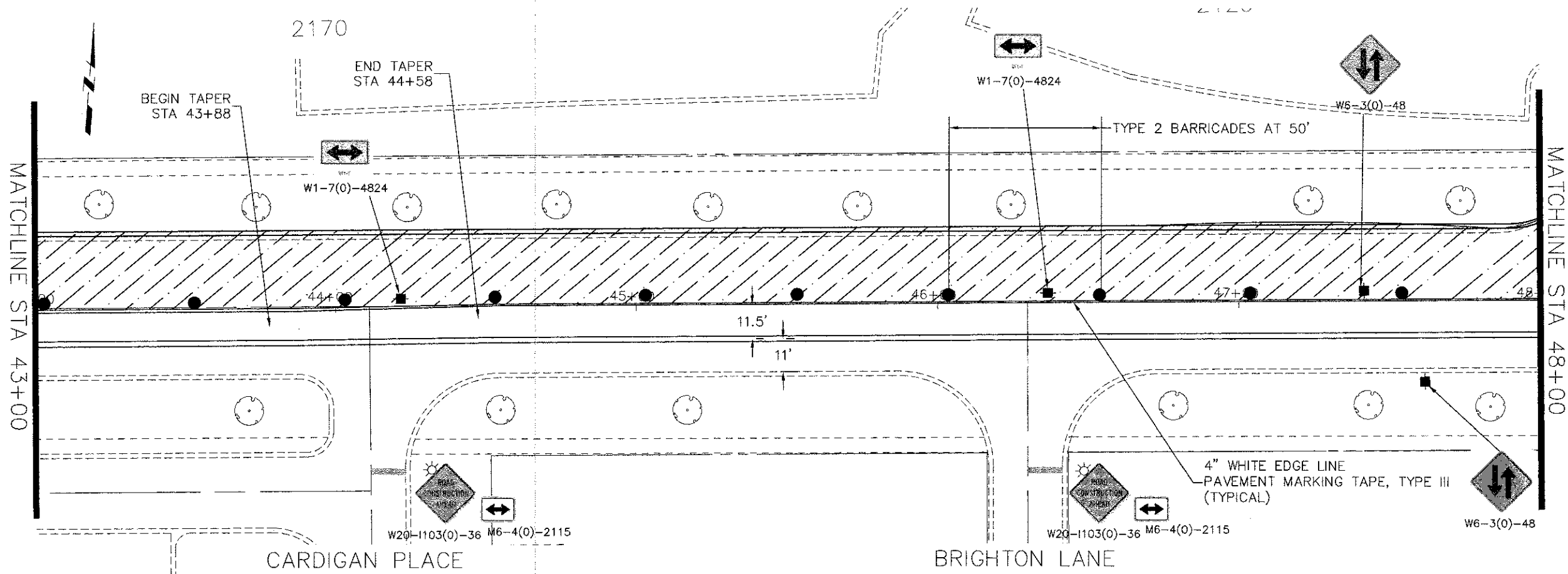
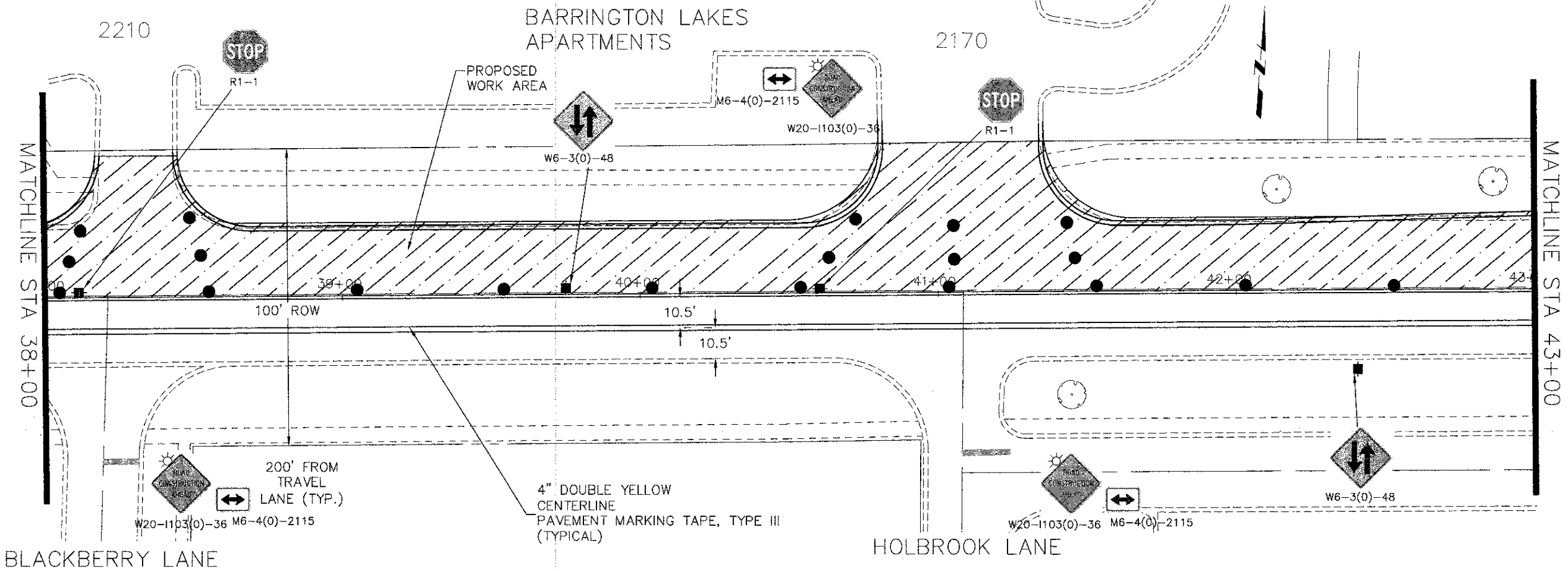

FILE NAME =
Hassell Plan-Profile.dwg

DESIGNED -	REVISED -
DRAWN -	REVISED -
CHECKED -	REVISED -
DATE -	REVISED -

**STATE OF ILLINOIS
DEPARTMENT OF TRANSPORTATION**

Hassell Road STP Project
Construction Staging 1
SCALE: 1" = 20' SHEET NO. 5 OF 18 SHEETS STA. 38+00 TO STA 48+00

F.A.U. RTE.	SECTION	COUNTY	TOTAL SHEETS	SHEET NO.
1100	11-00087-00-FP	Cook	164	35
CONTRACT NO. 63770			ILLINOIS FED. AID PROJECT CMM 9003(757)	

PLAN	DESIGNED	DATE
	PLOTTED	
	ALIGNED	
	CHECKED	
	NO.	
	DATE	

PROFILE	DESIGNED	DATE
	PLOTTED	
	GRADES	
	CHECKED	
	NO.	
	DATE	

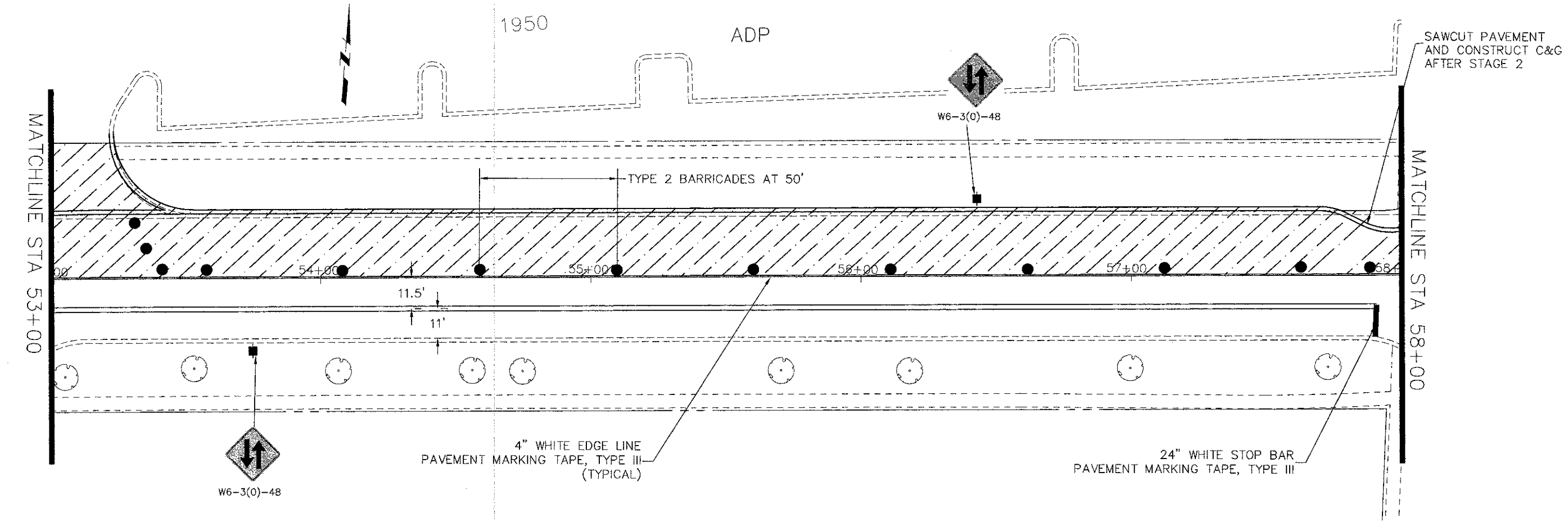
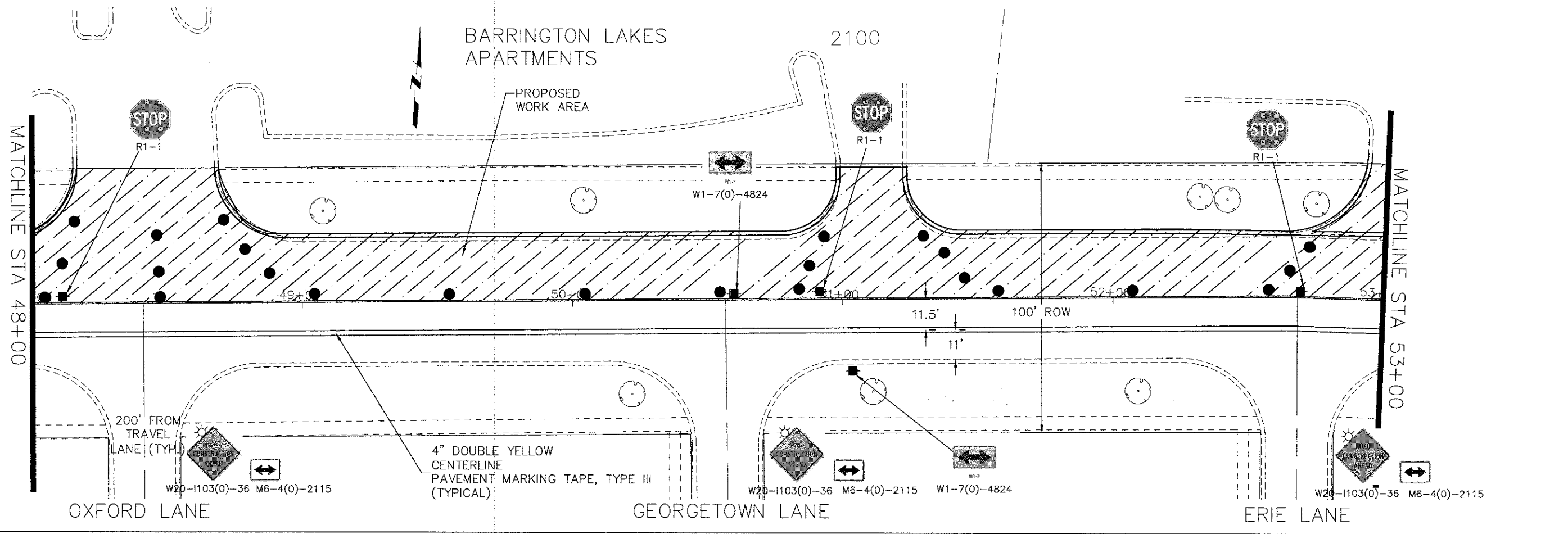

FILE NAME =
Hassell Plan-Profile.dwg

DESIGNED -	REVISÉ -
DRAWN -	REVISÉ -
CHECKED -	REVISÉ -
DATE -	REVISÉ -

**STATE OF ILLINOIS
DEPARTMENT OF TRANSPORTATION**

Hassell Road STP Project
Construction Staging 1

SCALE: 1" = 20' SHEET NO. 6 OF 18 SHEETS STA. 48+00 TO STA 58+00

F.A.U. RTE.	SECTION	COUNTY	TOTAL SHEETS	SHEET NO.
1100	11-00087-00-FP	Cook	164	36
CONTRACT NO. 63770			ILLINOIS FED. AID PROJECT CMM 9003(757)	

PLAN SURVEYED
 SLOTTED
 NOTE BOOK
 NO. OF WAY CHECKED
 DATE
 NAME

PROFILE SURVEYED
 SLOTTED
 NOTE BOOK
 NO. OF WAY CHECKED
 DATE
 NAME

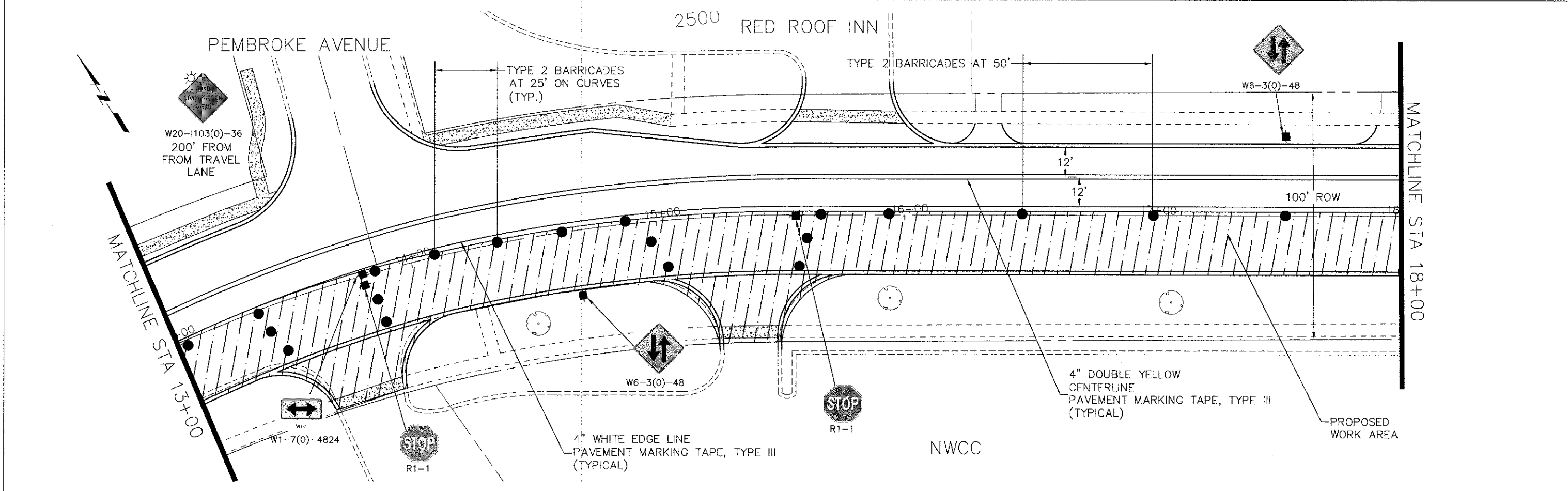
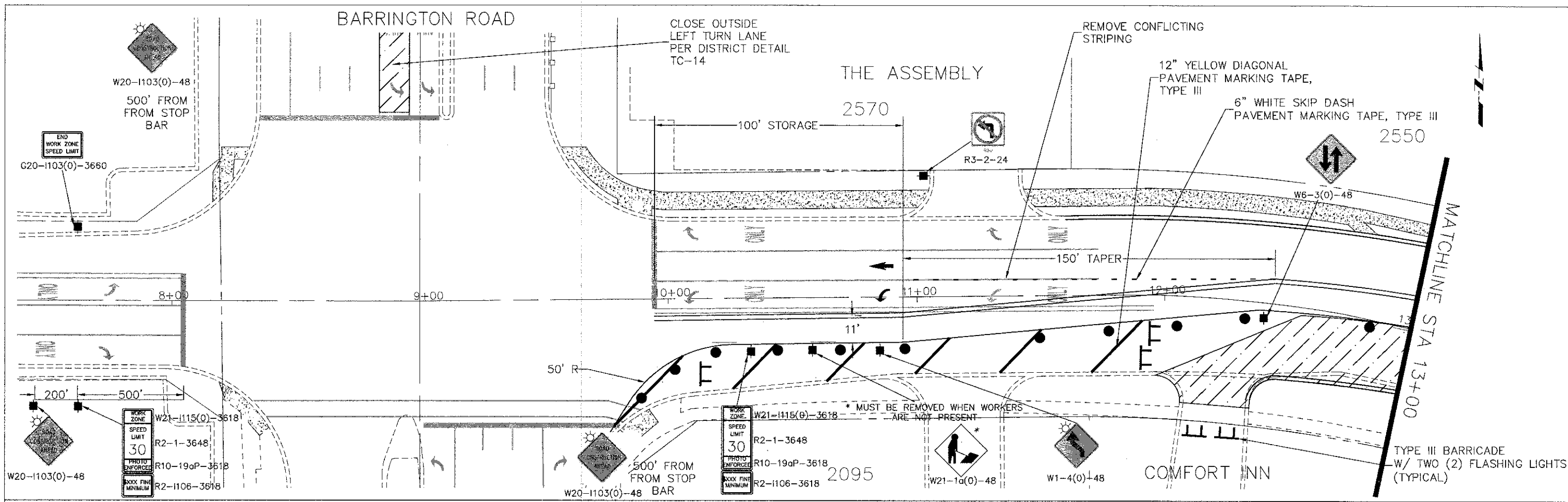

PLAN	DESIGNED	DATE
	BY	
	CHECKED	
	DATE	
	NOTED	
	DATE	
	REVISIONS	
	NO.	

PROFILE	DESIGNED	DATE
	BY	
	CHECKED	
	DATE	
	NOTED	
	DATE	
	REVISIONS	
	NO.	

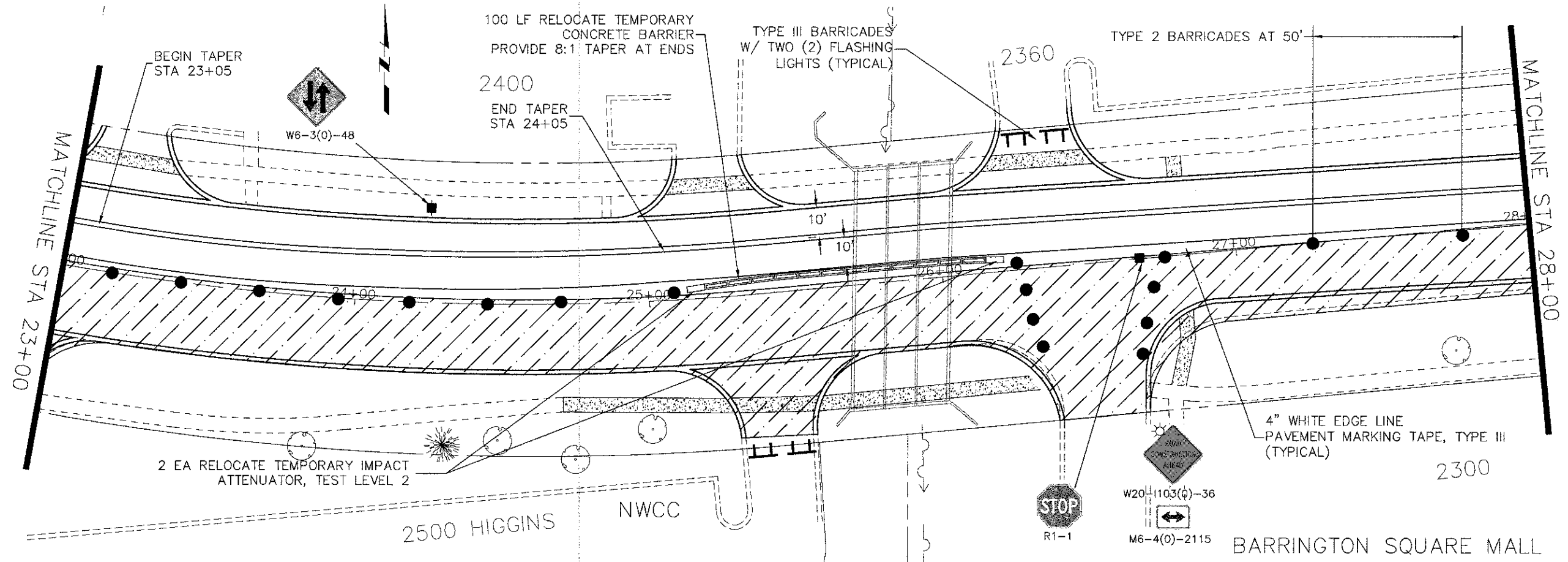
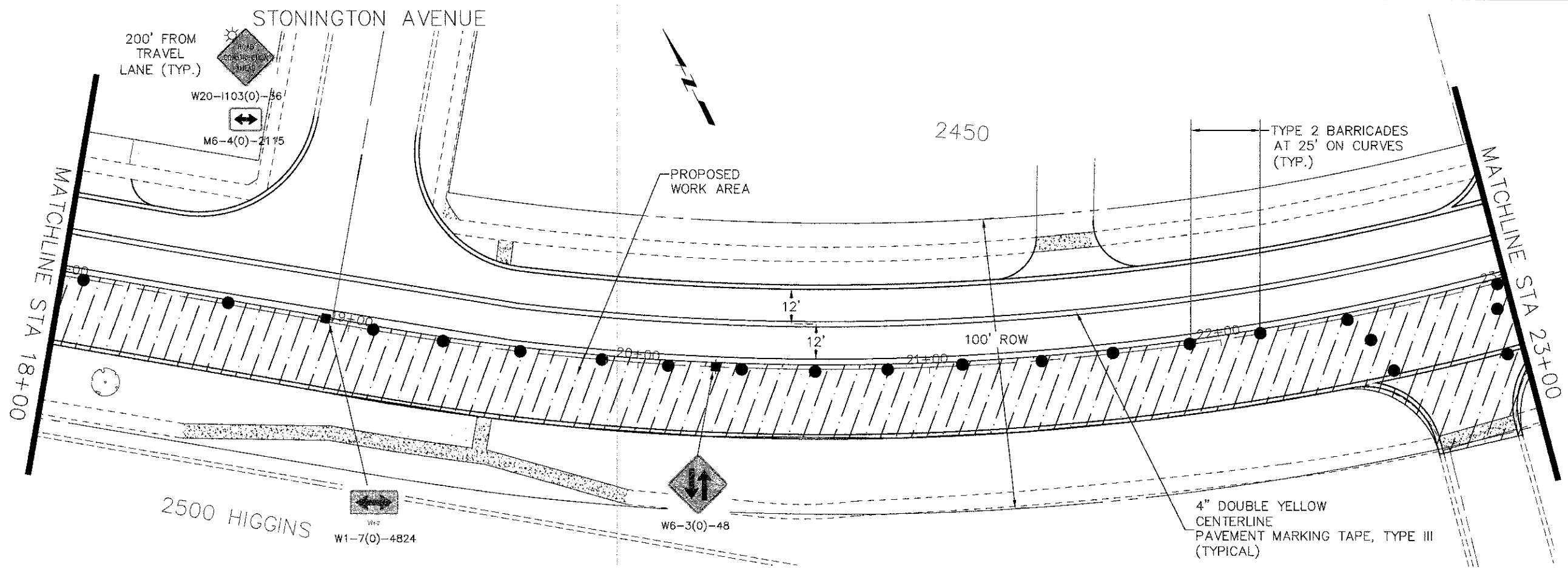

FILE NAME	DESIGNED	REVISIONS
Hassell Plan-Profile.dwg	BY	NO.
	CHECKED	
	DATE	
	NOTED	
	DATE	

DESIGNED	REVISIONS
DRAWN	NO.
CHECKED	
DATE	

**STATE OF ILLINOIS
DEPARTMENT OF TRANSPORTATION**

Hassell Road STP Project
Construction Staging 2

SCALE: 1" = 20' SHEET NO. 9 OF 18 SHEETS STA. 18+00 TO STA 28+00

F.A.U. RTE.	SECTION	COUNTY	TOTAL SHEETS	SHEET NO.
1100	11-00087-00-FP	Cook	164	39
CONTRACT NO. 63770			ILLINOIS FED. AID PROJECT CMM 9003(757)	

PLAN	SURVEYED	DATE	BY
	NOTE BOOK ALIGNMENT CHECKED		
	NO. OF P.W. CHECKED		
	DATE		

PROFILE	DESIGNED	DATE	BY
	NOTE BOOK GRADES CHECKED		
	NO. OF P.W. CHECKED		
	DATE		

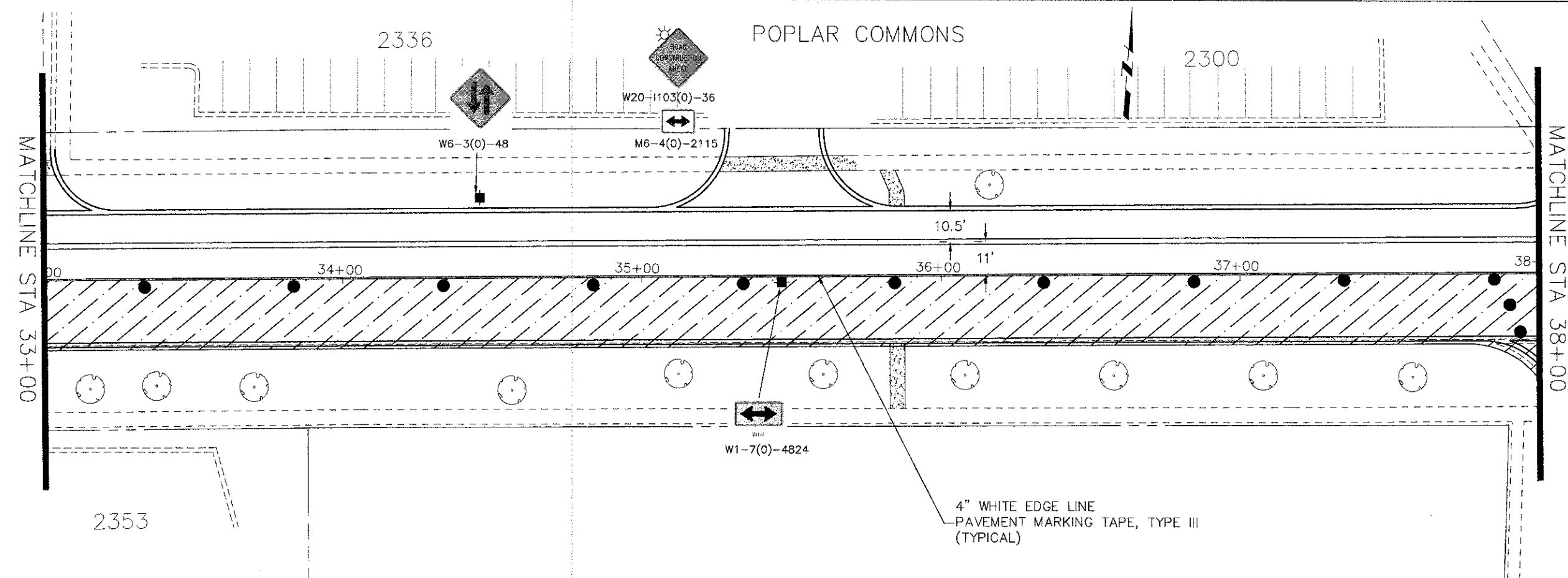
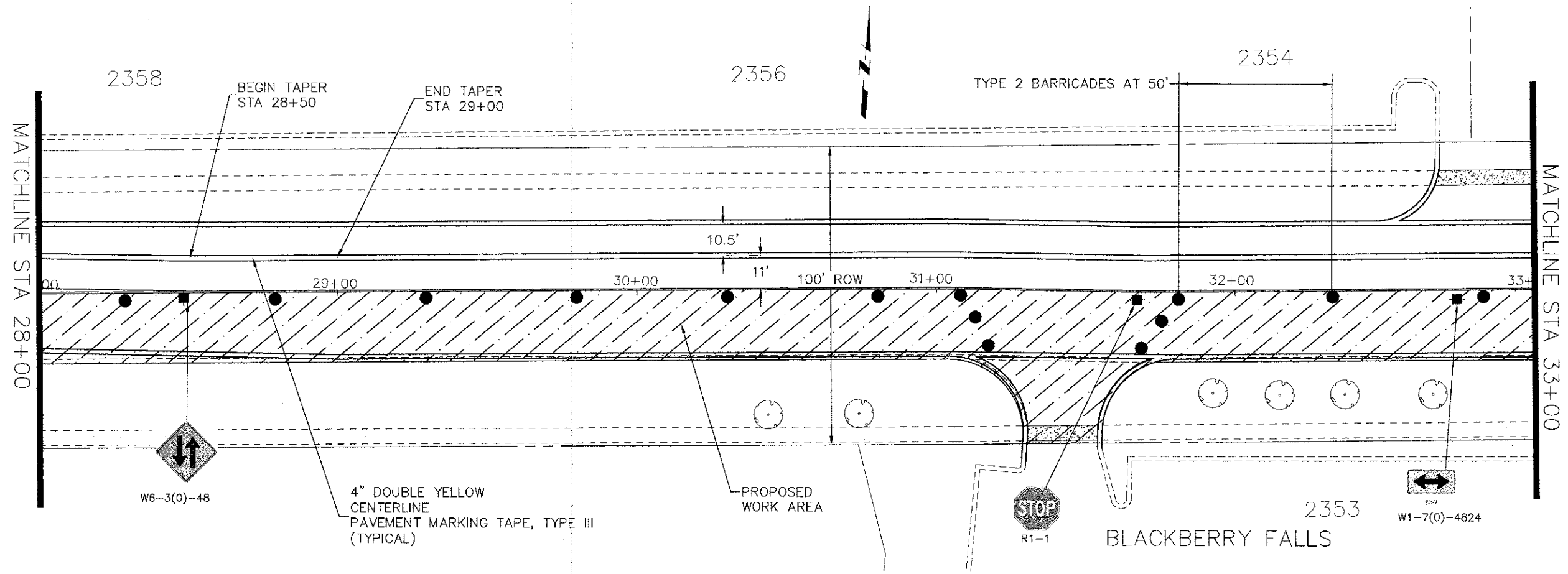

FILE NAME =	DESIGNED -	REVISED -
Hassell Plan-Profile.dwg	DRAWN -	REVISED -
	CHECKED -	REVISED -
	DATE -	REVISED -

**STATE OF ILLINOIS
DEPARTMENT OF TRANSPORTATION**

Hassell Road STP Project
Construction Staging 2

SCALE: 1" = 20' SHEET NO. 10 OF 18 SHEETS STA. 28+00 TO STA 38+00

F.A.U. R.T.E.	SECTION	COUNTY	TOTAL SHEETS	SHEET NO.
1100	11-00087-00-FP	Cook	164	40
CONTRACT NO. 63770				
ILLINOIS FED. AID PROJECT CMM 9003(757)				

PLAN	SURVEYED	DATE	BY
	ALIGNED		
	NOTED		
	CHECKED		
	NO.		
NOTE: BOOK ALIGNMENT CHECKED BY: _____			
NOTE: BOOK GRADES CHECKED BY: _____			
NOTE: BOOK STRUCTURE NOTATIONS CHECKED BY: _____			
DATE: _____			
BY: _____			

PROFILE	SURVEYED	DATE	BY
	ALIGNED		
	NOTED		
	CHECKED		
	NO.		
NOTE: BOOK GRADES CHECKED BY: _____			
NOTE: BOOK STRUCTURE NOTATIONS CHECKED BY: _____			
DATE: _____			
BY: _____			

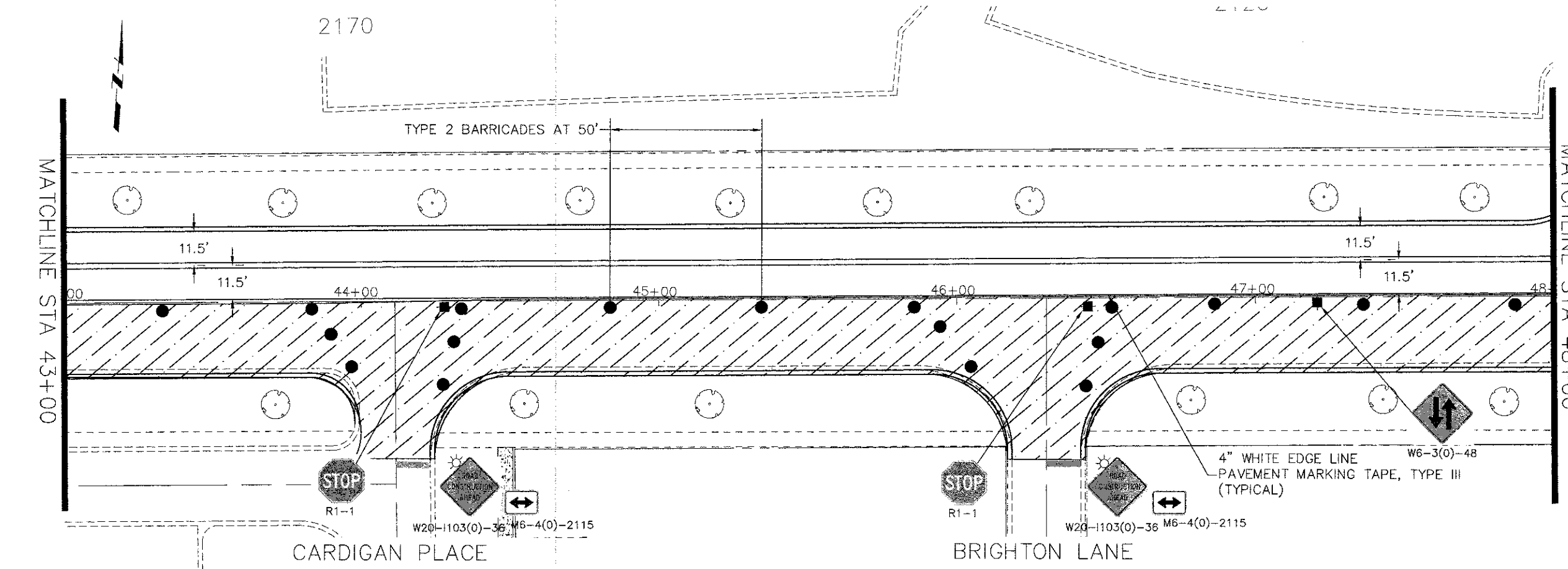
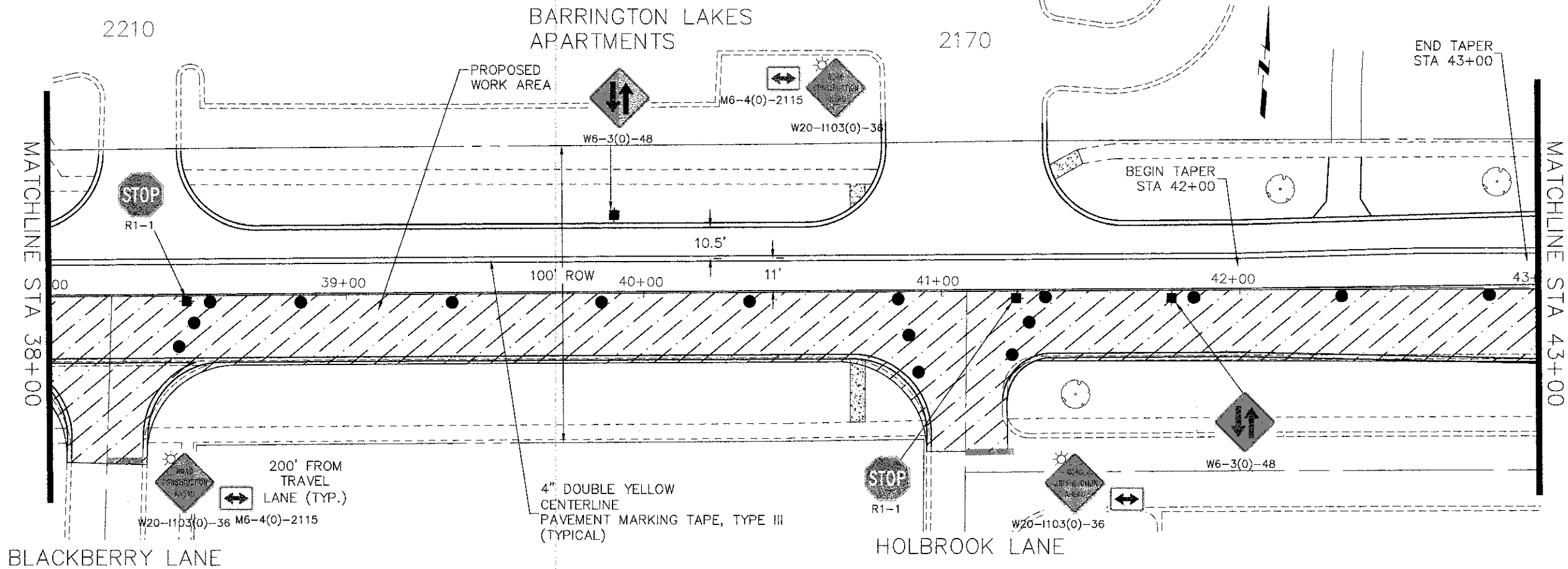

FILE NAME =	DESIGNED --	REVISED --
Hassell Plan-Profile.dwg	DRAWN --	REVISED --
	CHECKED --	REVISED --
	DATE --	REVISED --

**STATE OF ILLINOIS
DEPARTMENT OF TRANSPORTATION**

Hassell Road STP Project
Construction Staging 2

SCALE: 1" = 20' SHEET NO. 11 OF 18 SHEETS STA. 38+00 TO STA 48+00

F.A.U. RTE.	SECTION	COUNTY	TOTAL SHEETS	SHEET NO.
1100	11-00087-00-FP	Cook	164	41
CONTRACT NO. 63770				
ILLINOIS FED. AID PROJECT CMM 9003(757)				

PLAN	SURVEYED	DATE	BY
	PLOTTED		
	NOTE BOOK		
	ALIGNMENT CHECKED		
	NO.		
	NO.		
	NO.		

PROFILE	SURVEYED	DATE	BY
	PLOTTED		
	NOTE BOOK		
	ALIGNMENT CHECKED		
	NO.		
	NO.		
	NO.		

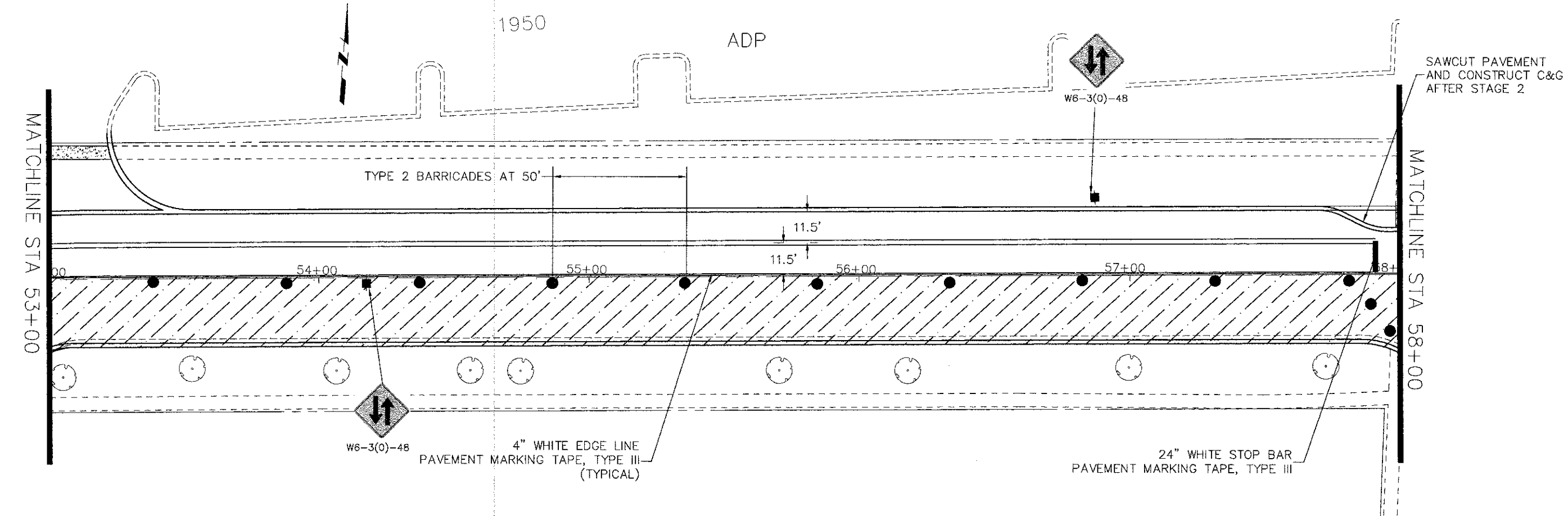
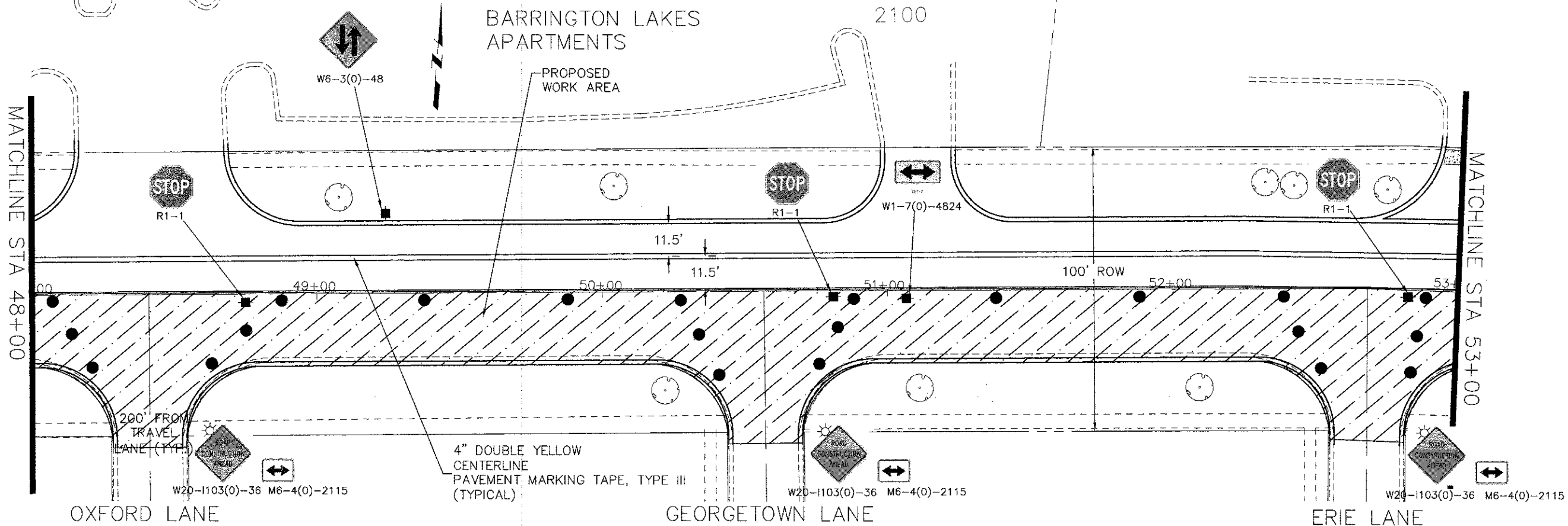

FILE NAME = Hassell Plan-Profile.dwg	DESIGNED -- DRAWN -- CHECKED -- DATE --	REVISED -- REVISED -- REVISED -- REVISED --	STATE OF ILLINOIS DEPARTMENT OF TRANSPORTATION	Hassell Road STP Project Construction Staging 2	F.A.U. RTE. 1100	SECTION 11-00087-00-FP	COUNTY Cook	TOTAL SHEETS 164	SHEET NO. 42	CONTRACT NO. 63770	ILLINOIS FED. AID PROJECT CMM 9003(757)
SCALE: 1" = 20'				SHEET NO. 12 OF 18 SHEETS		STA. 48+00 TO STA 58+00					

PLAN	DESIGNED	DATE	BY
	NOTED		
	FLIGHT		
	GRADES CHECKED		
	STRUCTURE NOTATION CHG		
	NO.		

PROFILE	DESIGNED	DATE	BY
	NOTED		
	FLIGHT		
	GRADES CHECKED		
	STRUCTURE NOTATION CHG		
	NO.		

24" WHITE STOP BAR
PAVEMENT MARKING TAPE, TYPE III

SAWCUT PAVEMENT
AND CONSTRUCT C&G
AFTER STAGE 2

MATCHLINE STA 58+00

KENSINGTON LANE

4" DOUBLE YELLOW
CENTERLINE
PAVEMENT MARKING TAPE, TYPE III

DRUMS OR BARRICADES AT 25'

W6-3(0)-48

* MUST BE REMOVED WHEN WORKERS
ARE NOT PRESENT

W21-1a(0)-48

EXISTING 4" DOUBLE
YELLOW CENTERLINE

MATCHLINE STA 62+00

EXISTING 4" WHITE
CENTER SKIPS



R1-1

200' FROM
TRAVEL
LANE (TYP.)

W20-1103(0)-36 M6-4(0)-2115

PROPOSED
WORK AREA

W1-4(0)-48

4" WHITE EDGE LINE
PAVEMENT MARKING TAPE, TYPE III

1901

12" YELLOW DIAGONALS
@ 75' SPACING
PAVEMENT MARKING TAPE, TYPE III

REMOVE ALL EXISTING
CONFLICTING STRIPING
(TYPICAL)

MATCHLINE STA 62+00

FLASHING ARROW
BOARD

END
WORK ZONE
SPEED LIMIT
G20-1103(0)-3660

WORK
ZONE
SPEED
LIMIT
30
PHOTO
ENFORCER
R2-1115(0)-3618
R2-1-3648
R10-19aP-3818
R2-1106-3618



W4-2L(0)-48

1890



W20-5(0)-48



W20-1103(0)-48

MATCHLINE STA 62+00

165' TAPER

63+00

64+00

65+00

66+00

250' 200' 200'

FILE NAME =	DESIGNED -	REVISED -
Hassell Plan-Profile.dwg	DRAWN -	REVISED -
	CHECKED -	REVISED -
	DATE -	REVISED -

STATE OF ILLINOIS
DEPARTMENT OF TRANSPORTATION

Hassell Road STP Project
Construction Staging 2

SCALE: 1" = 20' SHEET NO. 13 OF 18 SHEETS STA. 58+00 TO STA 62+00

F.A.U. RTE.	SECTION	COUNTY	TOTAL SHEETS	SHEET NO.
1100	11-00087-00-FP	Cook	164	43
CONTRACT NO. 63770			ILLINOIS FED. AID PROJECT CMM 9003(757)	

PLAN	DRAWN	DATE	BY
	PLOTTED		
	ALIGNED		
	CHECKED		
	NO.		

PROFILE	DRAWN	DATE	BY
	PLOTTED		
	ALIGNED		
	CHECKED		
	NO.		

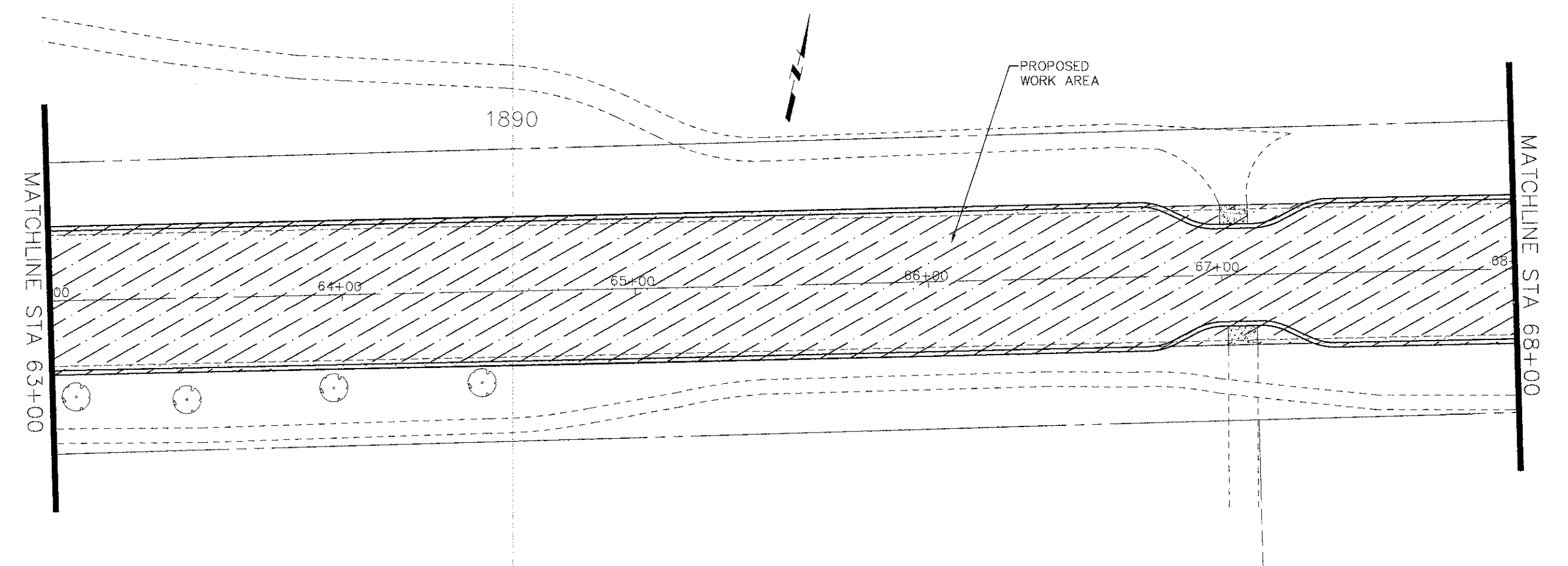
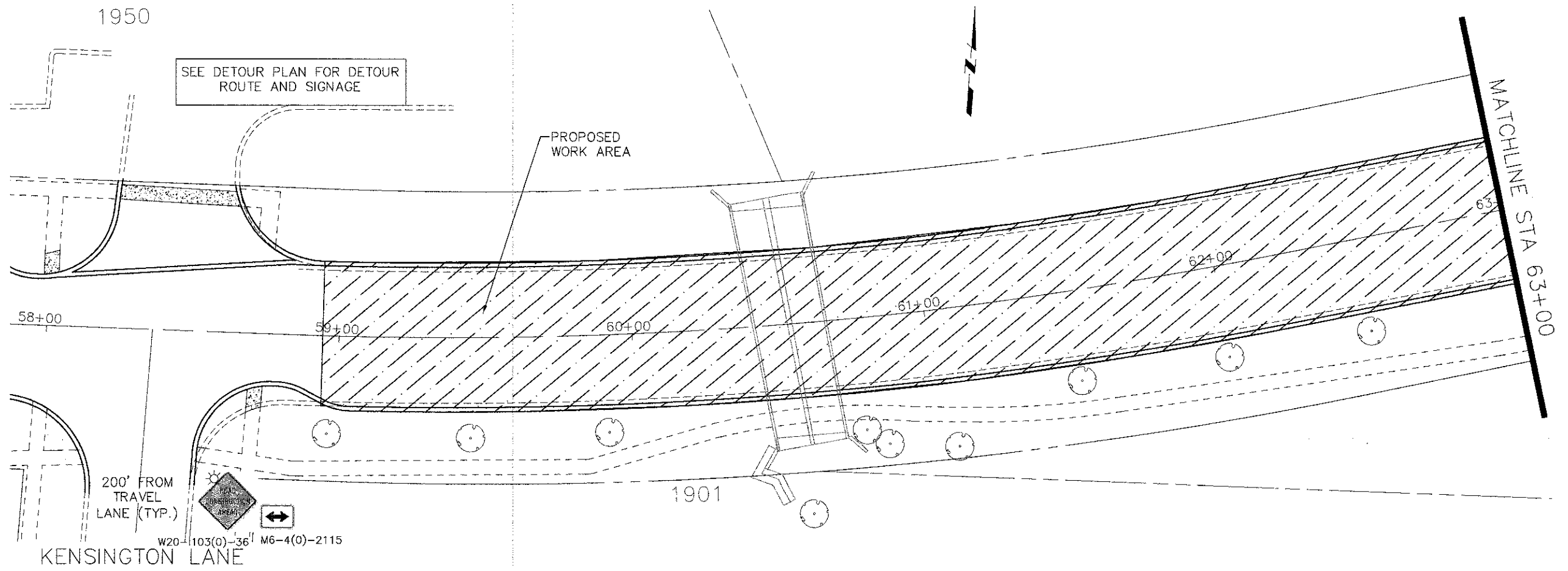

FILE NAME = Hassell Plan-Profile.dwg	DRAWN -	REVISD -	STATE OF ILLINOIS DEPARTMENT OF TRANSPORTATION	Hassell Road STP Project Construction Staging 3	F.A.U. RTE.	SECTION	COUNTY	TOTAL SHEETS	SHEET NO.
	CHECKED -	REVISD -			1100	11-00087-00-FP	Cook	164	44
	DATE -	REVISD -			CONTRACT. NO. 63770		ILLINOIS FED. AID PROJECT CMM 9003(757)		

SCALE: 1" = 20' SHEET NO. 14 OF 18 SHEETS STA. 58+00 TO STA 68+00

SEE DETOUR PLAN FOR DETOUR ROUTE AND SIGNAGE

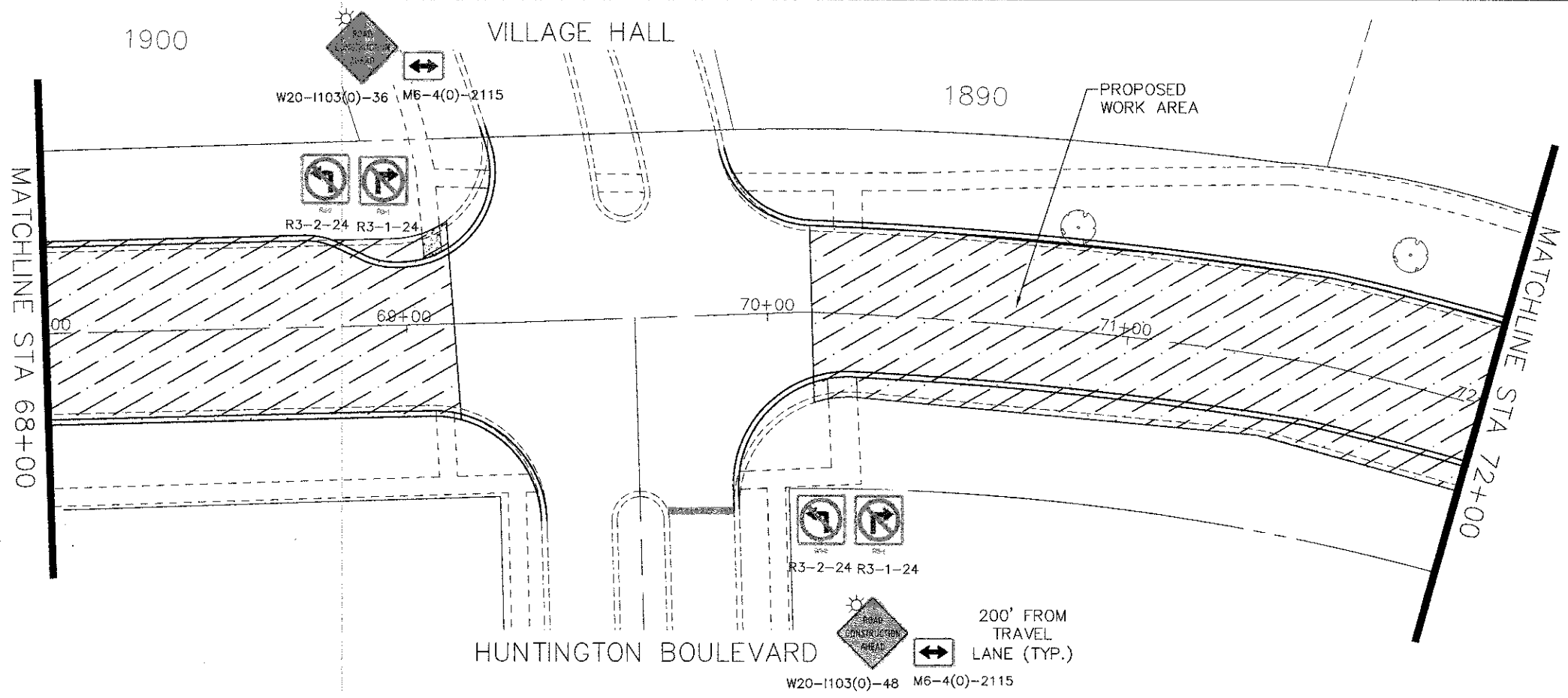

PLAN	SURVEYED	DATE	BY
	PLOTTED		
	ALIGNED		
	CHECKED		
	NO. _____		

PROFILE	SURVEYED	DATE	BY
	PLOTTED		
	GRADES CHECKED		
	NO. _____		

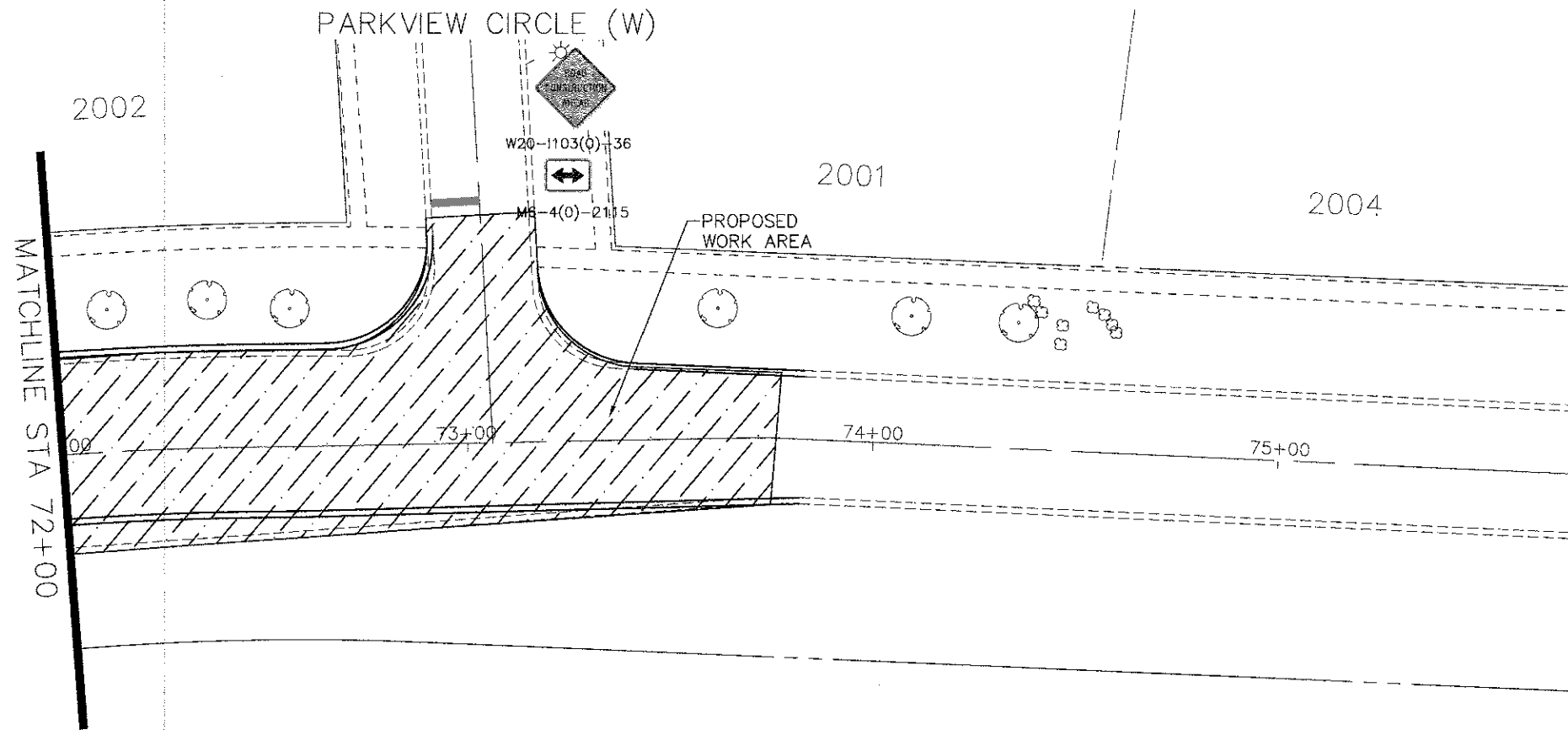

FILE NAME =	
Hassell Plan-Profile.dwg	

DRAWN -	REVISED -
CHECKED -	REVISED -
DATE -	REVISED -

STATE OF ILLINOIS
DEPARTMENT OF TRANSPORTATION

Hassell Road STP Project
Construction Staging 3

SCALE: 1" = 20' SHEET NO. 15 OF 18 SHEETS STA. 68+00 TO STA 75+00

F.A.U. RTE.	SECTION	COUNTY	TOTAL SHEETS	SHEET NO.
1100	11-00087-00-FP	Cook	164	45
CONTRACT NO. 63770			ILLINOIS FED. AID PROJECT CMM 9003(757)	

PLANNED	DATE	BY
DESIGNED		
PLOTTED		
NOTE BOOK ALIGNED CHECKED		
NO. OF PLY CHECKED		
NO.		

PROFILE	DATE	BY
DESIGNED		
PLOTTED		
NOTE BOOK GRADES CHECKED		
NO. OF NOTES		
NO.		

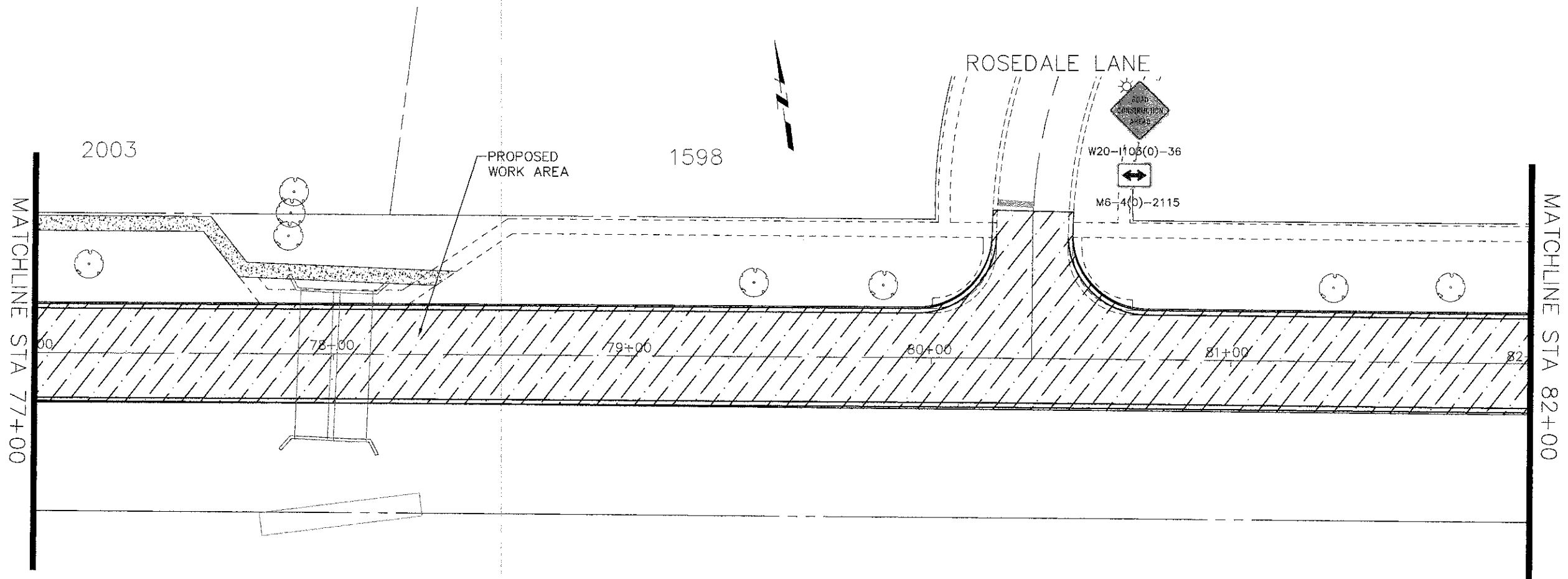
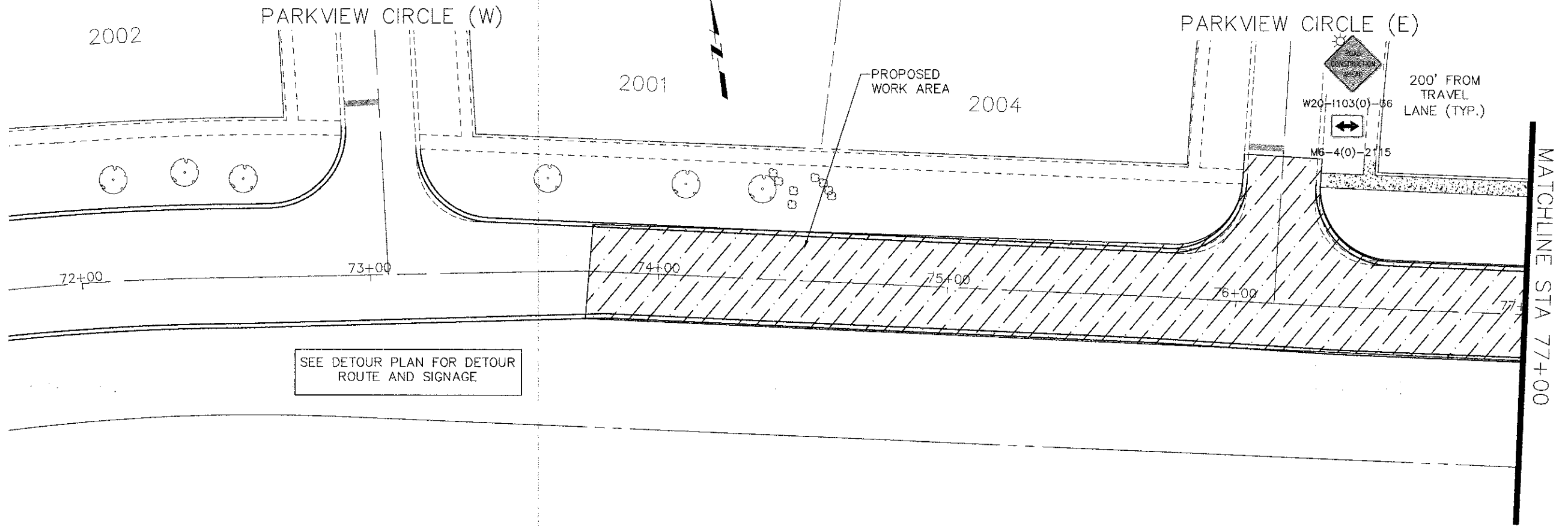

FILE NAME =	
Hassell Plan-Profile.dwg	

DRAWN -	REVISD -
CHECKED -	REVISD -
DATE -	REVISD -

STATE OF ILLINOIS
DEPARTMENT OF TRANSPORTATION

Hassell Road STP Project
Construction Staging 4

SCALE: 1" = 20'

SHEET NO. 16 OF 18 SHEETS

STA. 78+00 TO STA 88+00

F.A.U. RTE.	SECTION	COUNTY	TOTAL SHEETS	SHEET NO.
1100	11-00087-00-FP	Cook	164	46
CONTRACT NO. 63770				
ILLINOIS FED. AID PROJECT CMM 9003(757)				

SEE DETOUR PLAN FOR DETOUR ROUTE AND SIGNAGE

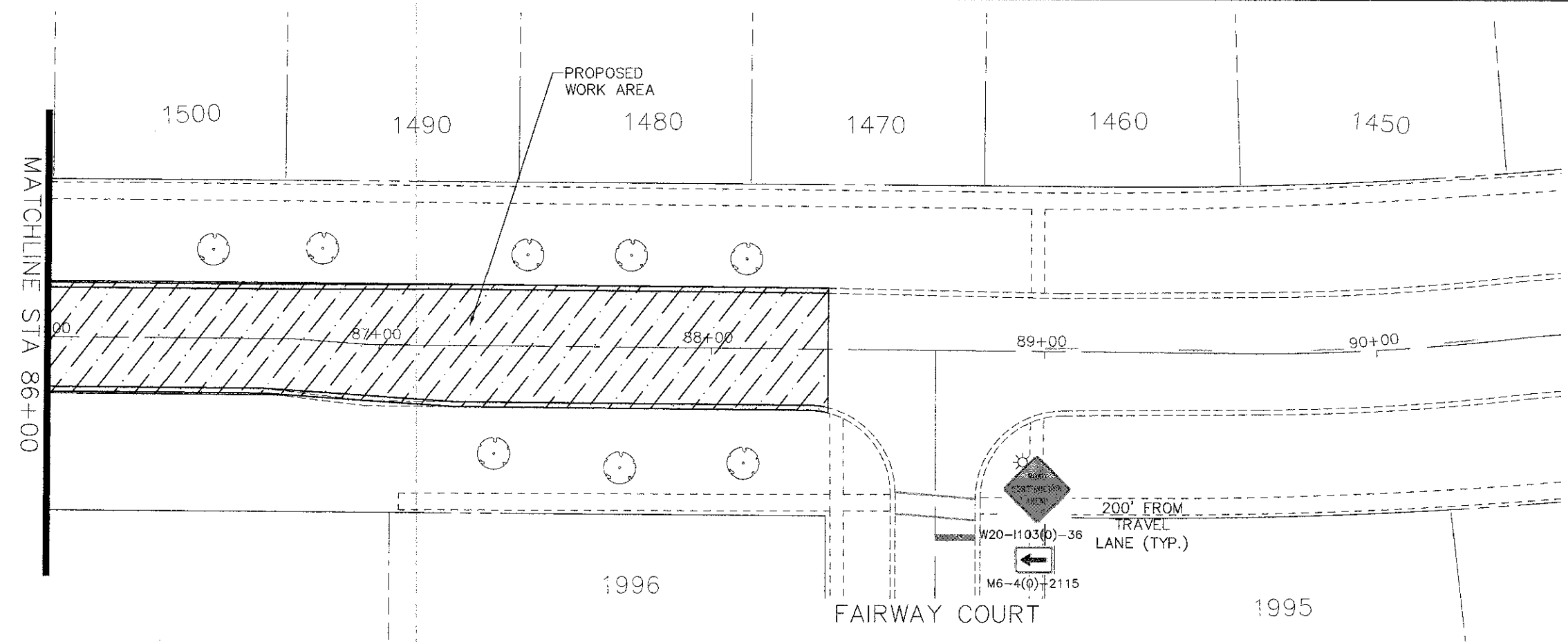
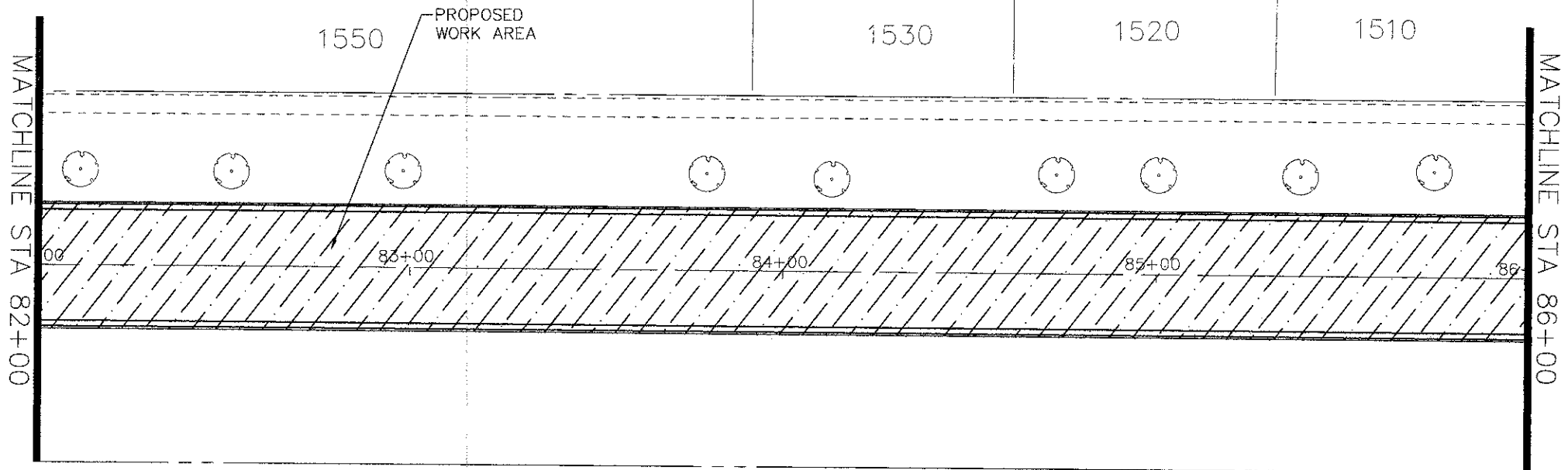

PLAN	SURVEYED	DATE
	NOTE BOOK ALIGNED	
	RT. OF WAY CHECKED	
	NO.	

PROFILE	SURVEYED	DATE
	NOTE BOOK GRADES CHECKED	
	NO.	

FILE NAME =
Hassell Plan-Profile.dwg

DRAWN -	REVISED -
CHECKED -	REVISED -
DATE -	REVISED -

STATE OF ILLINOIS
DEPARTMENT OF TRANSPORTATION

Hassell Road STP Project
Construction Staging 4

SCALE: 1" = 20' SHEET NO. 17 OF 18 SHEETS STA. 82+00 TO STA 90+00

F.A.U. RTE.	SECTION	COUNTY	TOTAL SHEETS	SHEET NO.
1100	11-00087-00-FP	Cook	164	47
CONTRACT NO. 63770				
ILLINOIS FED. AID PROJECT CMM 9003(757)				

PLAN	SURVEYED	DATE
	PLOTTED	
	NOTE BOOK ALIGNMENT CHECKED	
	NO.	
	DATE	
	BY	

PROFILE	SURVEYED	DATE
	PLOTTED	
	NOTE BOOK GRADES CHECKED	
	NO.	
	DATE	
	BY	

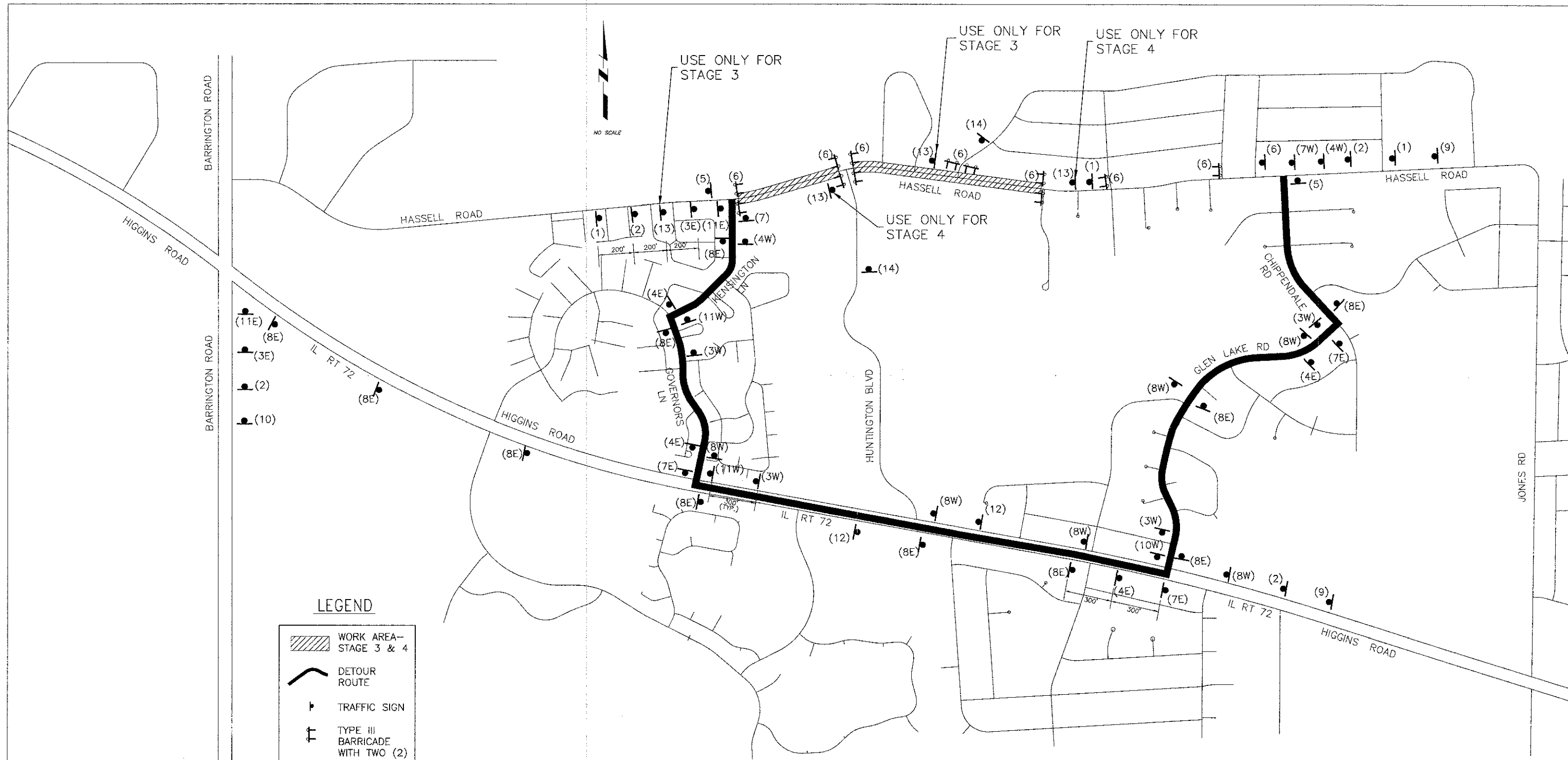

LEGEND

- WORK AREA-- STAGE 3 & 4
- DETOUR ROUTE
- TRAFFIC SIGN
- TYPE III BARRICADE WITH TWO (2) FLASHING LIGHTS

DETOUR SIGN LEGEND

(1) W20-3 (48"x 48")	(2) W20-2 (48"x 48")	(3) M3-3 OR M3-4 (24"x 18")	(4) M5-1R OR M5-1L (24"x 18")	(5) M4-8A (24"x 18")	(6) R11-2 (60"x 30")	(7) M4-9L (21"x 15")	(8) M4-8 (24"x 12") M6-3 (B/O) (21"x 15")	(9) R11-4 (60"x 30")	(10) R11-4 (60"x 30")	(11) M4-9R (24"x 15")	(12) (60"x 30")	(13) W20-3 (48"x 48")	(14) W20-3 (48"x 48")
-----------------------	-----------------------	------------------------------	--------------------------------	-----------------------	-----------------------	-----------------------	--	-----------------------	------------------------	------------------------	------------------	------------------------	------------------------

PLAN	SURVEYED	DATE	BY
	NOTED		
	CHECKED		
	BY		
	NO. OF PAGES		
	CAD FILE NAME		
	NO.		

PROFILE	SURVEYED	DATE	BY
	NOTED		
	CHECKED		
	BY		
	NO. OF PAGES		
	STRUCTURE NOTATION CH'G		
	NO.		

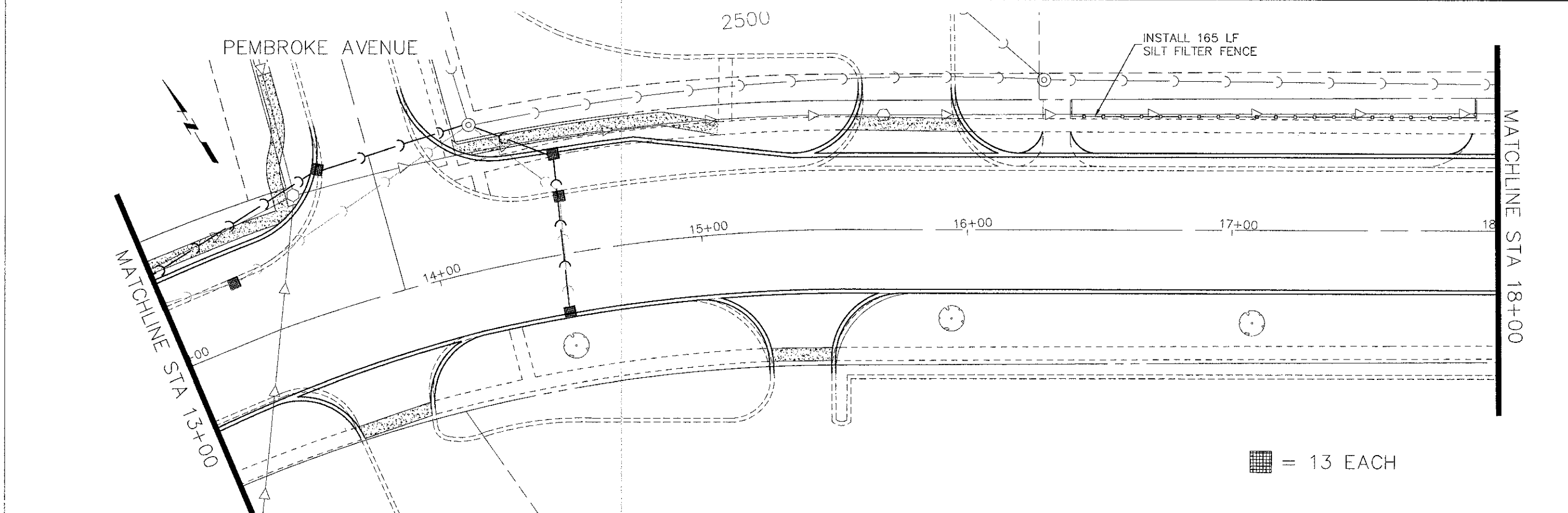
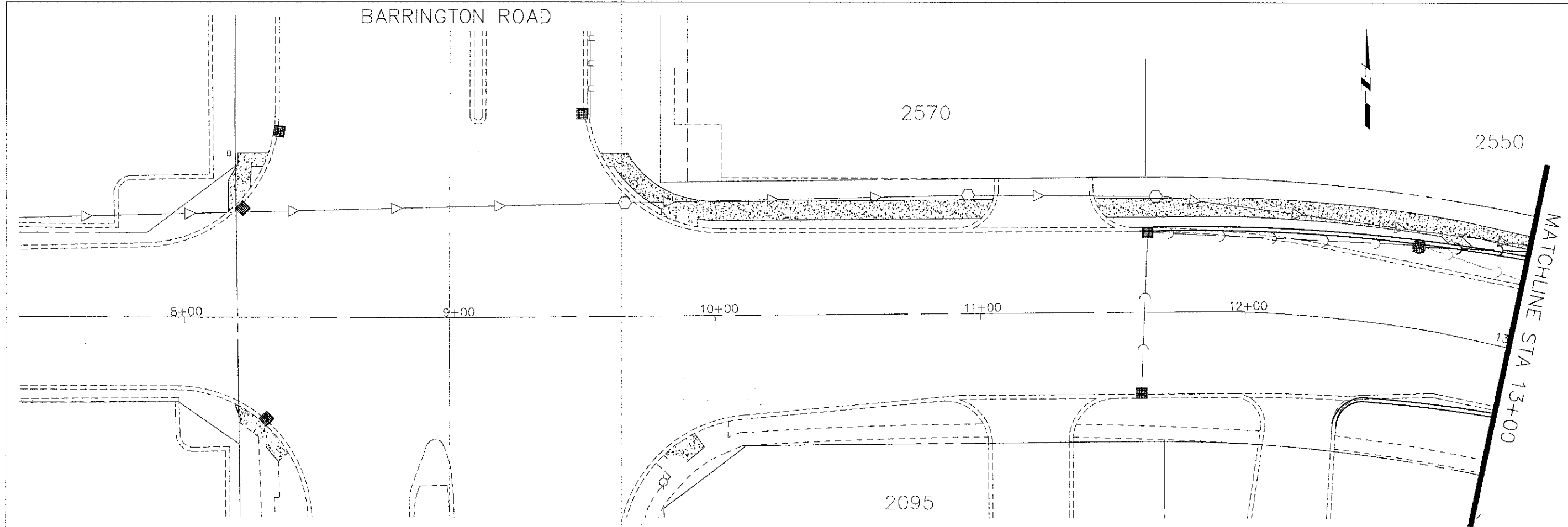

FILE NAME =	DESIGNED --	REVISED --
Hassell Plan-Profile.dwg	DRAWN --	REVISED --
	CHECKED --	REVISED --
	DATE --	REVISED --

DESIGNED --	REVISED --
DRAWN --	REVISED --
CHECKED --	REVISED --
DATE --	REVISED --

**STATE OF ILLINOIS
DEPARTMENT OF TRANSPORTATION**

Hassell Road STP Project
Erosion Control Plan

SCALE: 1" = 20' SHEET NO. 1 OF 8 SHEETS STA. 9+00 TO STA 18+00

F.A.U. RTE.	SECTION	COUNTY	TOTAL SHEETS	SHEET NO.
1100	11-00087-00-FP	Cook	164	49
				CONTRACT NO. 63770
ILLINOIS FED. AID PROJECT CMM 9003(757)				

PLAN	DESIGNED	DATE
	PLOTTED	
	ALIGNED	
	CHECKED	
	NO.	
	NAME	

PROFILE	DESIGNED	DATE
	PLOTTED	
	GRADES	
	CHECKED	
	NO.	
	NAME	

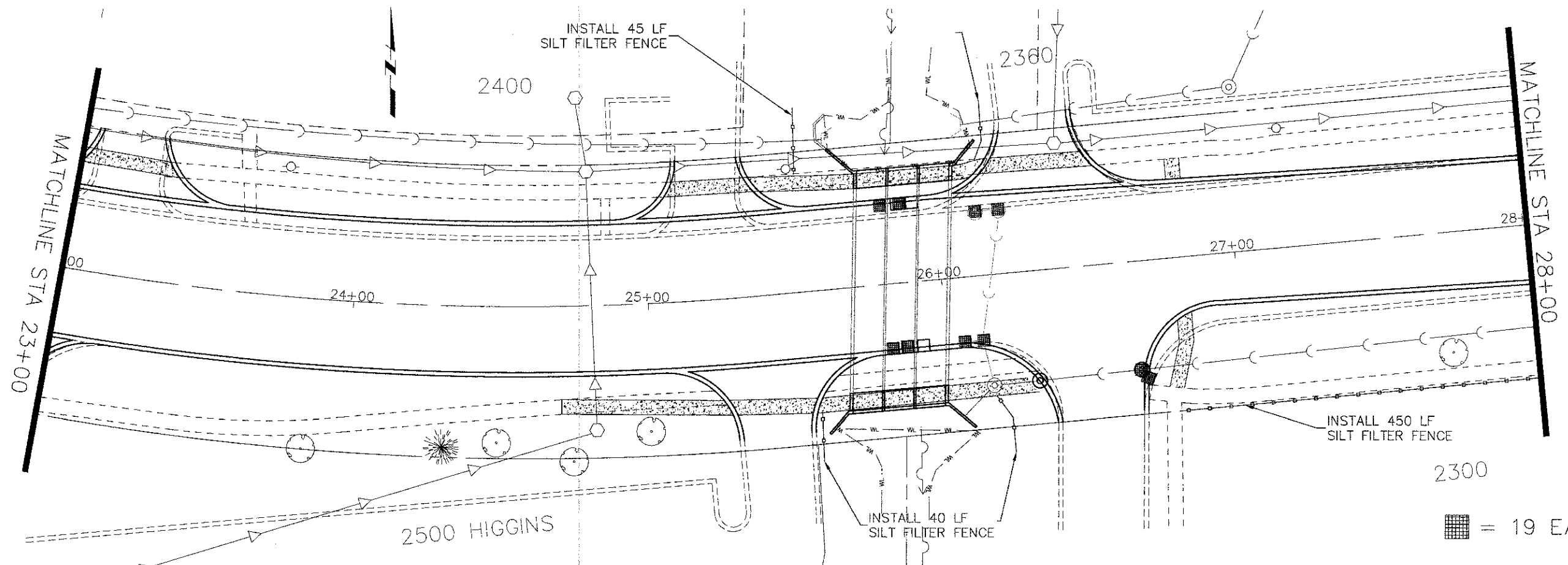
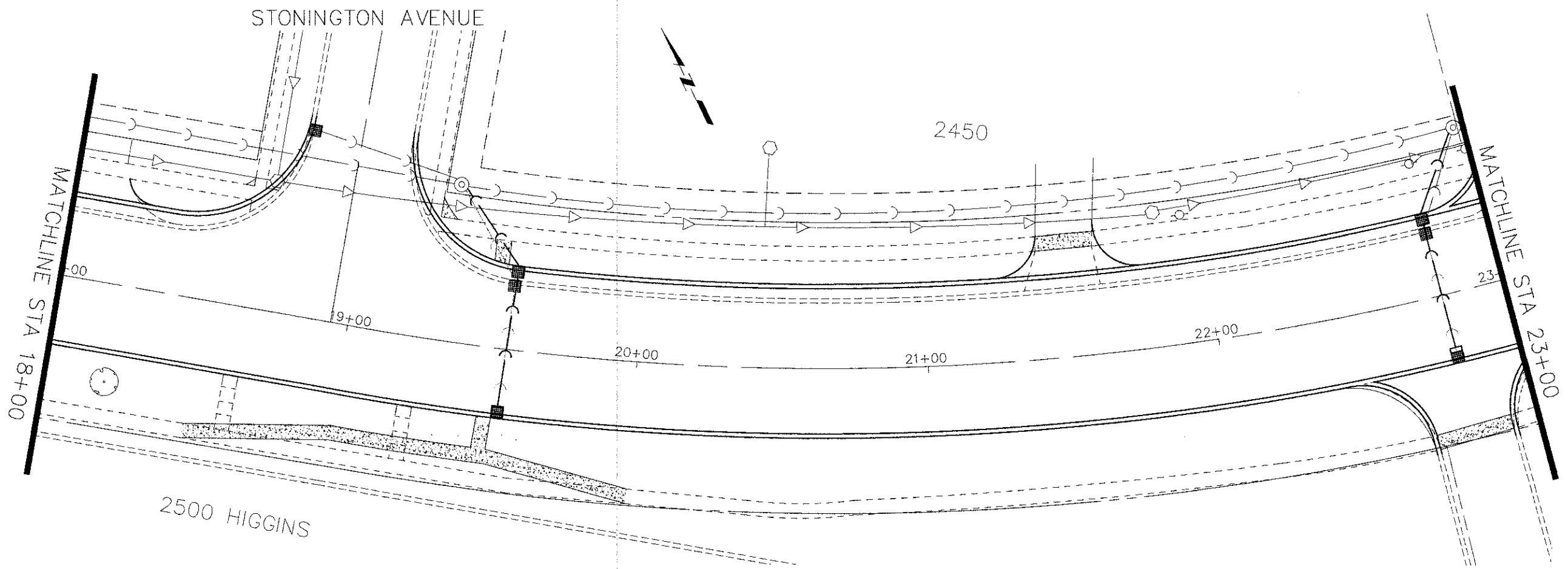

■ = 19 EACH

FILE NAME =
Hassell Plan-Profile.dwg

DESIGNED -	REVISED -
DRAWN -	REVISED -
CHECKED -	REVISED -
DATE -	REVISED -

**STATE OF ILLINOIS
DEPARTMENT OF TRANSPORTATION**

Hassell Road STP Project
Erosion Control Plan
SCALE: 1" = 20' SHEET NO. 2 OF 8 SHEETS STA. 18+00 TO STA 28+00

F.A.U. RTE.	SECTION	COUNTY	TOTAL SHEETS	SHEET NO.
1100	11-00087-00-FP	Cook	164	50
CONTRACT NO. 63770			ILLINOIS FED. AID PROJECT CMM 9003(757)	

PLAN	SURVEYED	BY	DATE
	PLOTTED		
	ALIGNED		
	CHECKED		
	NO.		

PROFILE	SURVEYED	BY	DATE
	PLOTTED		
	GRADES		
	CHECKED		
	NO.		

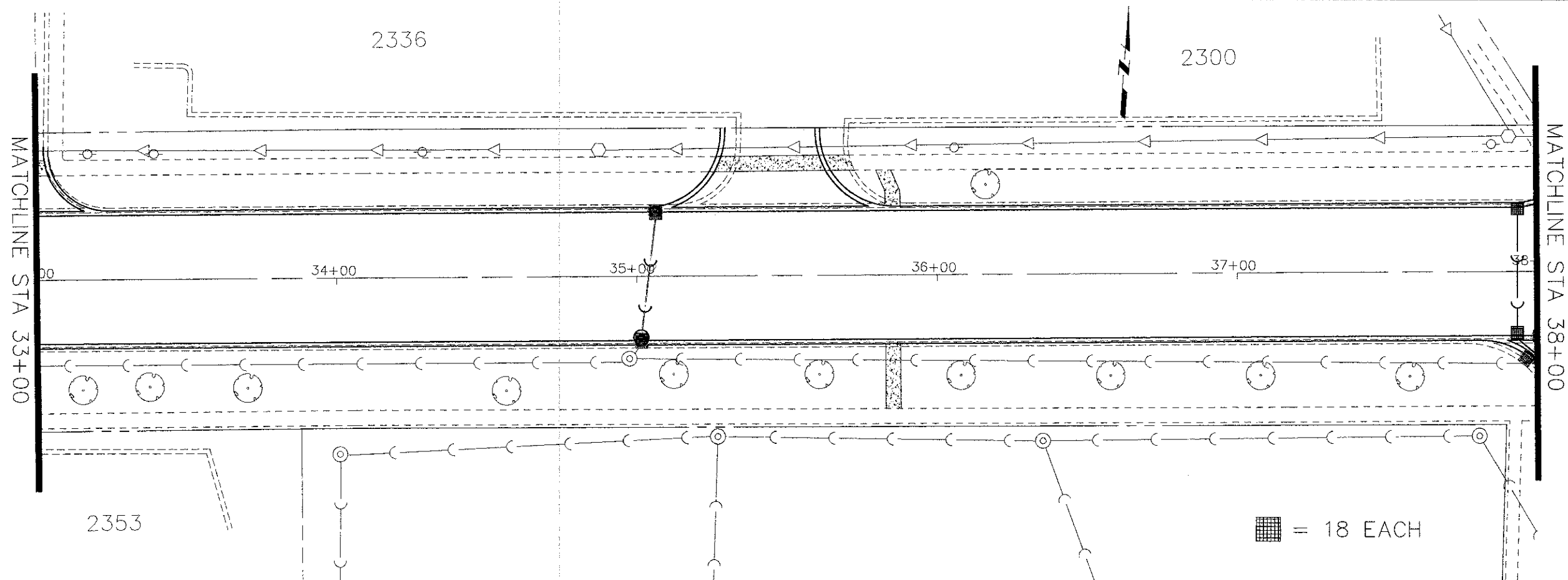
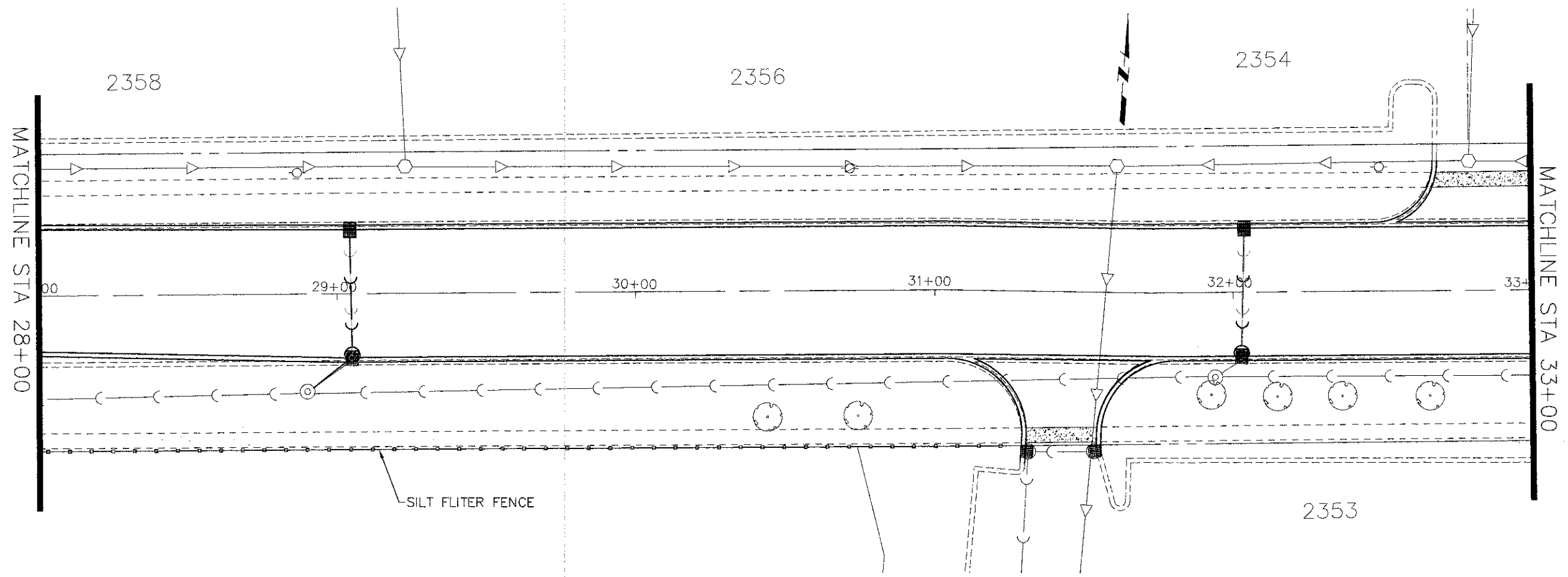

■ = 18 EACH

FILE NAME =
Hassell Plan-Profile.dwg

DESIGNED -	REVISD -
DRAWN -	REVISD -
CHECKED -	REVISD -
DATE -	REVISD -

**STATE OF ILLINOIS
DEPARTMENT OF TRANSPORTATION**

Hassell Road STP Project
Erosion Control Plan
SCALE: 1" = 20' SHEET NO. 3 OF 8 SHEETS STA. 28+00 TO STA 38+00

F.A.U. RTE.	SECTION	COUNTY	TOTAL SHEET SHEETS	NO.
1100	11-00087-00-FP	Cook	164	51
CONTRACT NO. 63770			ILLINOIS FED. AID PROJECT CMM 9003(757)	

PLAN	SURVEYED	PLOTTED	CHECKED
NOTE BOOK NO.	DATE	BY	DATE

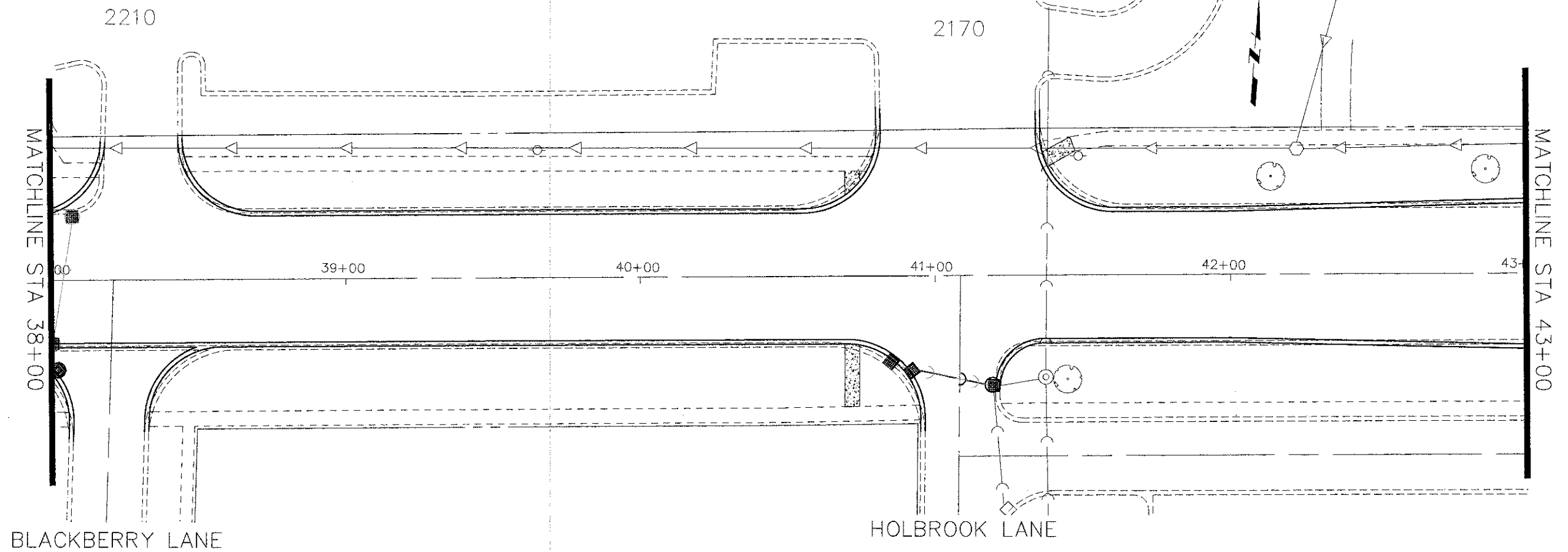

PROFILE	SURVEYED	PLOTTED	CHECKED
NOTE BOOK NO.	DATE	BY	DATE

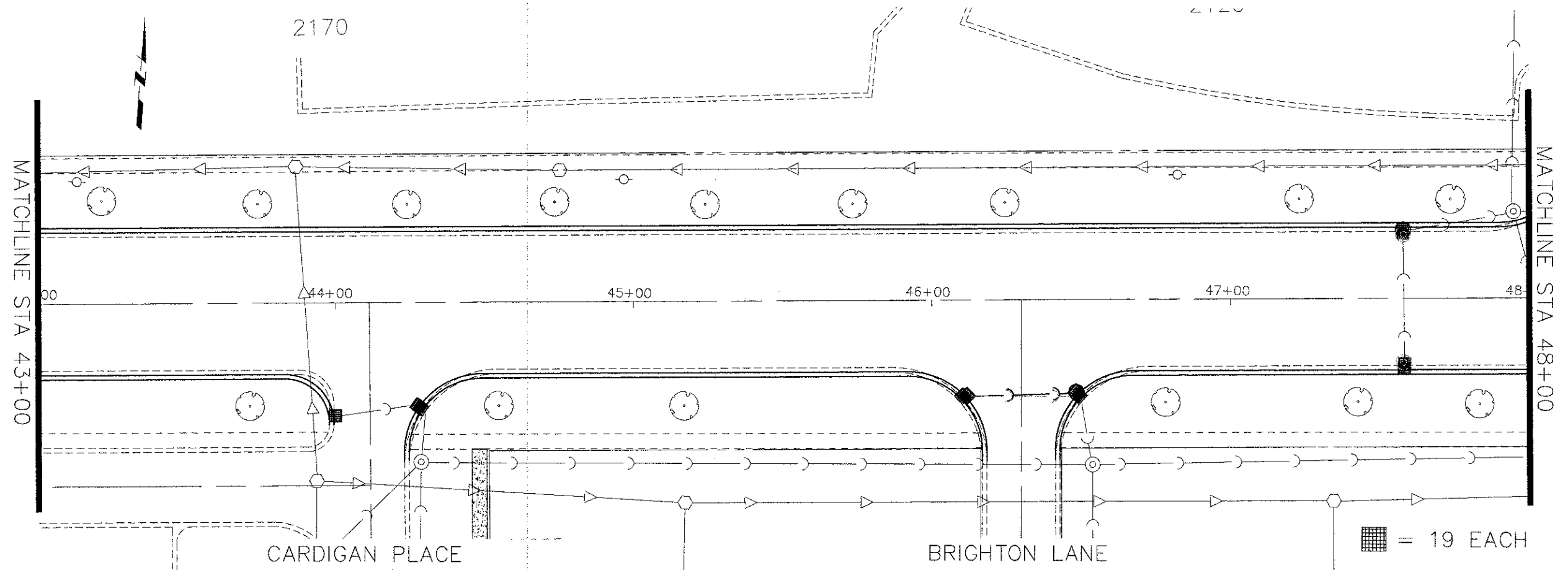

FILE NAME Hassell Plan-Profile.dwg	DESIGNED -	REVISIONS	STATE OF ILLINOIS DEPARTMENT OF TRANSPORTATION		Hassell Road STP Project Erosion Control Plan		F.A.U. RTE. 1100	SECTION 11-00087-00-FP	COUNTY Cook	TOTAL SHEETS 164	SHEET NO. 52	
	DRAWN -	REVISIONS	SCALE: 1" = 20'		SHEET NO. 4 OF 8 SHEETS		CONTRACT NO. 63770		ILLINOIS FED. AID PROJECT CMM 9003(757)			
	CHECKED -	REVISIONS	STA. 38+00 TO STA 48+00									
	DATE -	REVISIONS										

PLAN	DESIGNED	DATE	BY
	PLOTTED		
	GRADES CHECKED		
	STRUCTURE NOTATIONS OK'D		
	NOTE BOOK NO.		

PROFILE	DESIGNED	DATE	BY
	PLOTTED		
	GRADES CHECKED		
	STRUCTURE NOTATIONS OK'D		
	NOTE BOOK NO.		

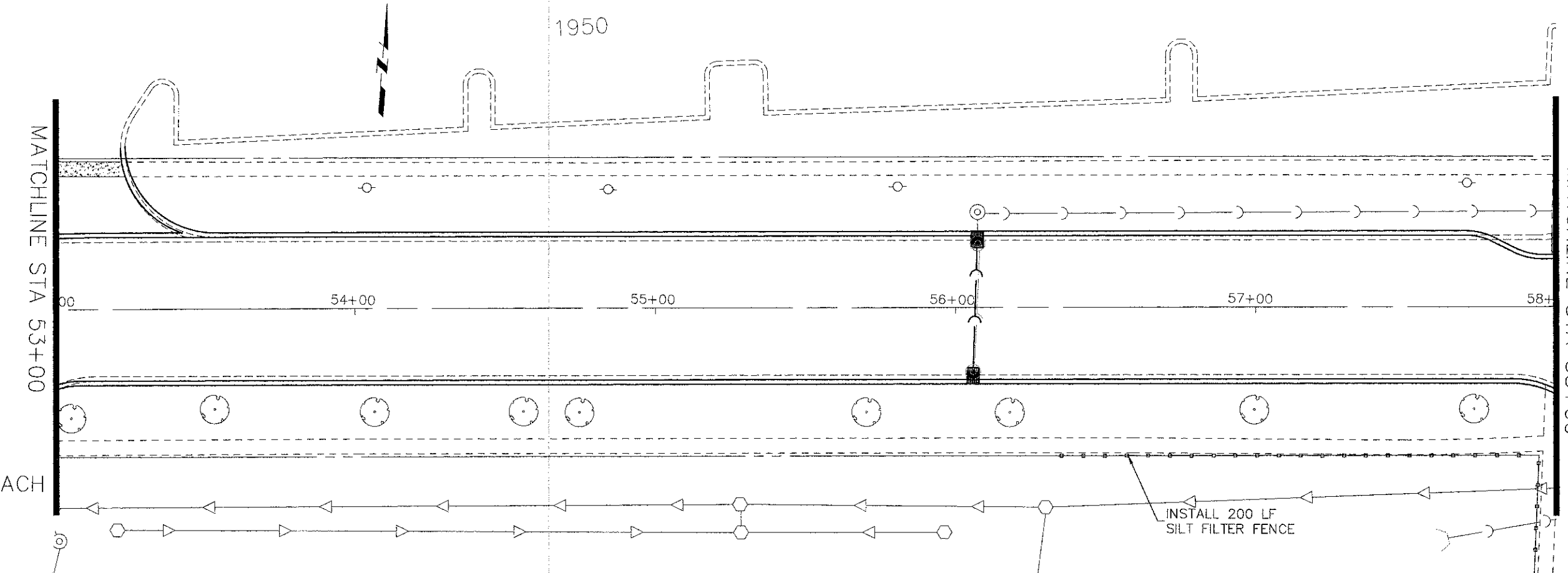
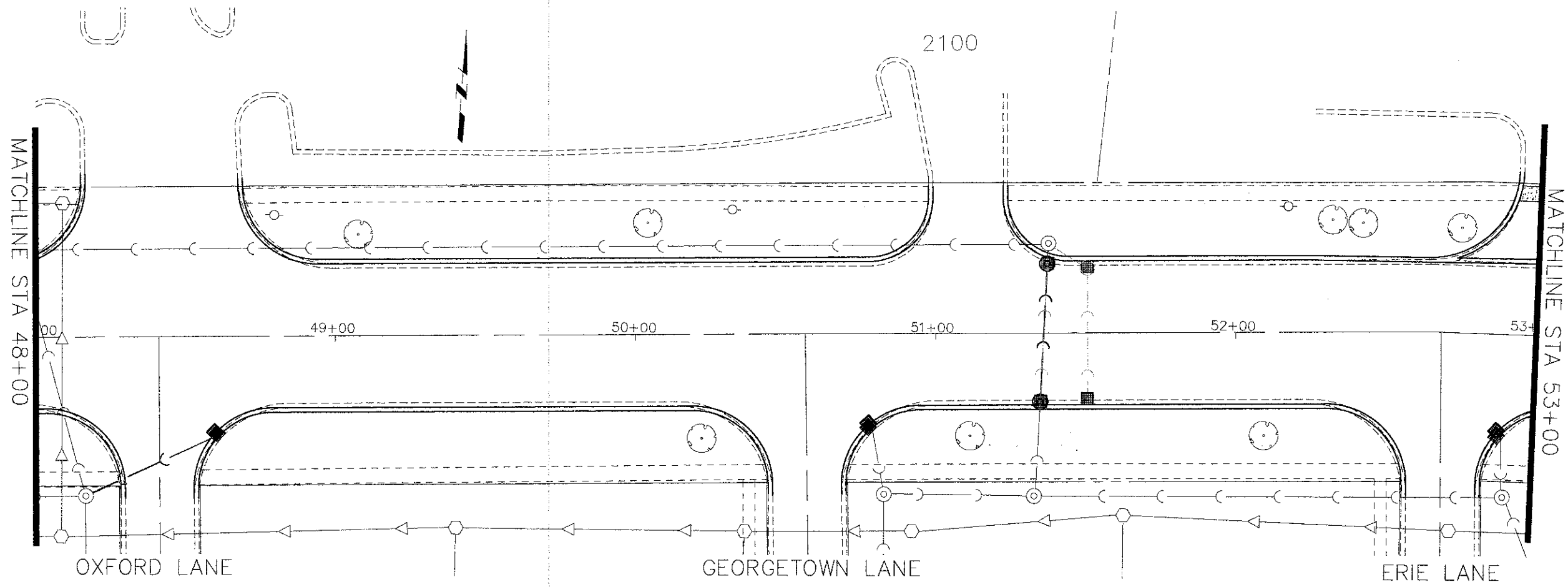

FILE NAME = Hassell Plan-Profile.dwg

DESIGNED -	REVISÉD -
DRAWN -	REVISÉD -
CHECKED -	REVISÉD -
DATE -	REVISÉD -

**STATE OF ILLINOIS
DEPARTMENT OF TRANSPORTATION**

Hassell Road STP Project
Erosion Control Plan

SCALE: 1" = 20' SHEET NO. 5 OF 8 SHEETS STA. 48+00 TO STA 58+00

F.A.U. RTE.	SECTION	COUNTY	TOTAL SHEETS	SHEET NO.
1100	11-00087-00-FP	Cook	164	53
CONTRACT NO. 63770			ILLINOIS FED. AID PROJECT CMM 9003(757)	

PLAN	SURVEYED	DATE	BY
	PLOTTED		
	CHECKED		
	DATE		
	BY		
	CHECKED		
	DATE		
	BY		
	CHECKED		
	DATE		
	BY		

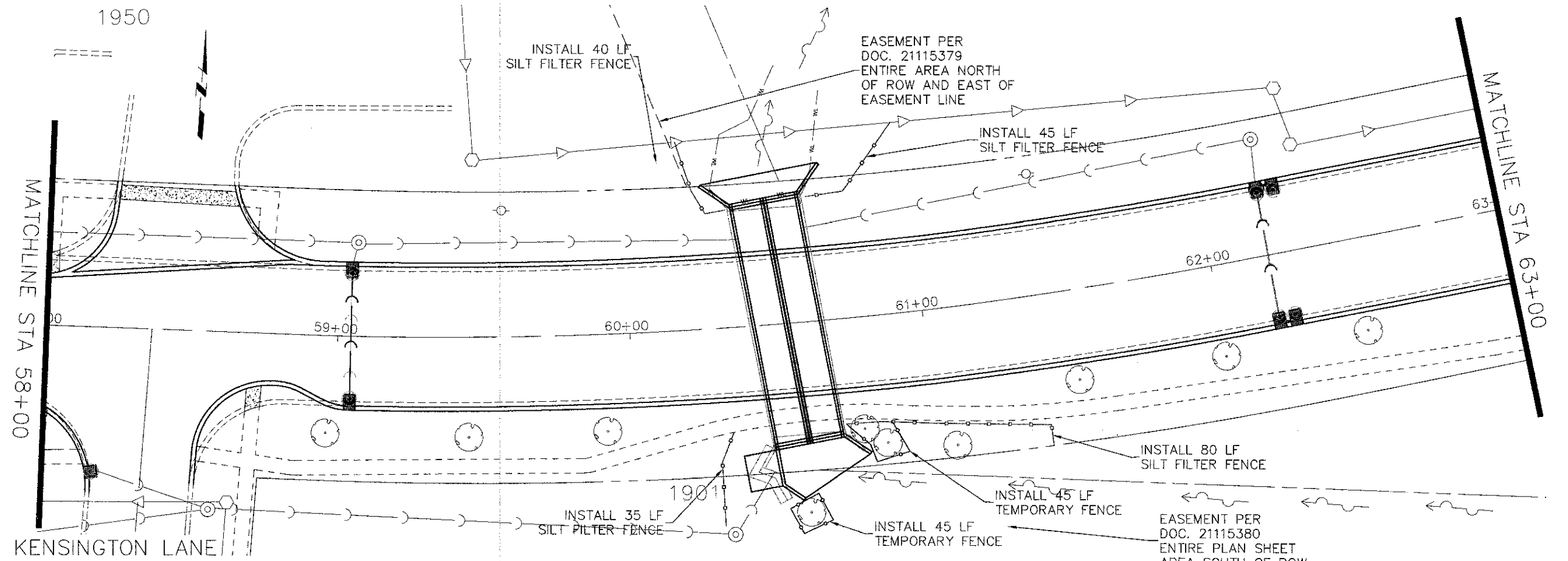

PROFILE	SURVEYED	DATE	BY
	PLOTTED		
	CHECKED		
	DATE		
	BY		
	CHECKED		
	DATE		
	BY		
	CHECKED		
	DATE		
	BY		

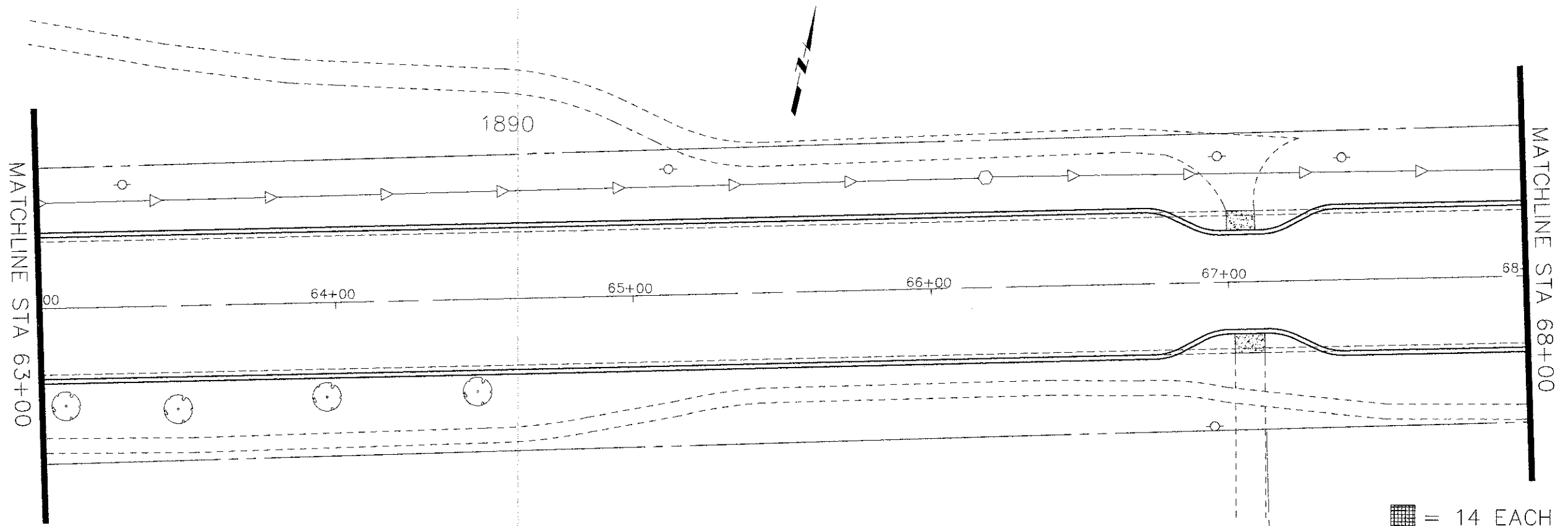

■ = 14 EACH

FILE NAME =
Hassell Plan-Profile.dwg

DESIGNED -	REVISED -
DRAWN -	REVISED -
CHECKED -	REVISED -
DATE -	REVISED -

**STATE OF ILLINOIS
DEPARTMENT OF TRANSPORTATION**

Hassell Road STP Project
Erosion Control Plan

SCALE: 1" = 20' SHEET NO. 6 OF 8 SHEETS STA. 58+00 TO STA 68+00

F.A.U. RTE.	SECTION	COUNTY	TOTAL SHEETS	SHEET NO.
1100	11-00087-00-FP	Cook	164	54
CONTRACT NO. 63770			ILLINOIS FED. AID PROJECT CMM 9003(757)	

PLAN	SURVEYED	DATE	BY
	PLOTTED		
	CHECKED		
	REVISIONS		
	NO. OF REVISIONS		
	DATE		
	BY		
	CHECKED		
	NO.		

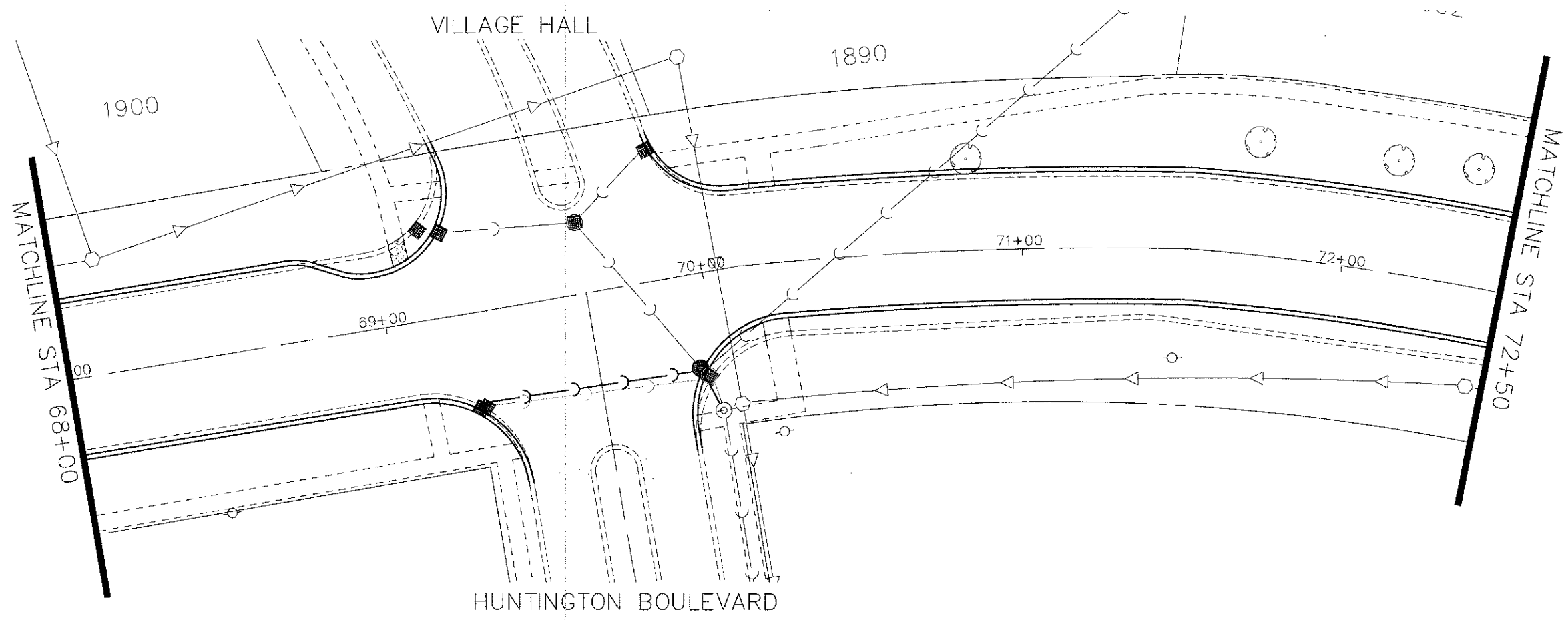

PROFILE	SURVEYED	DATE	BY
	PLOTTED		
	CHECKED		
	REVISIONS		
	NO. OF REVISIONS		
	DATE		
	BY		
	CHECKED		
	NO.		

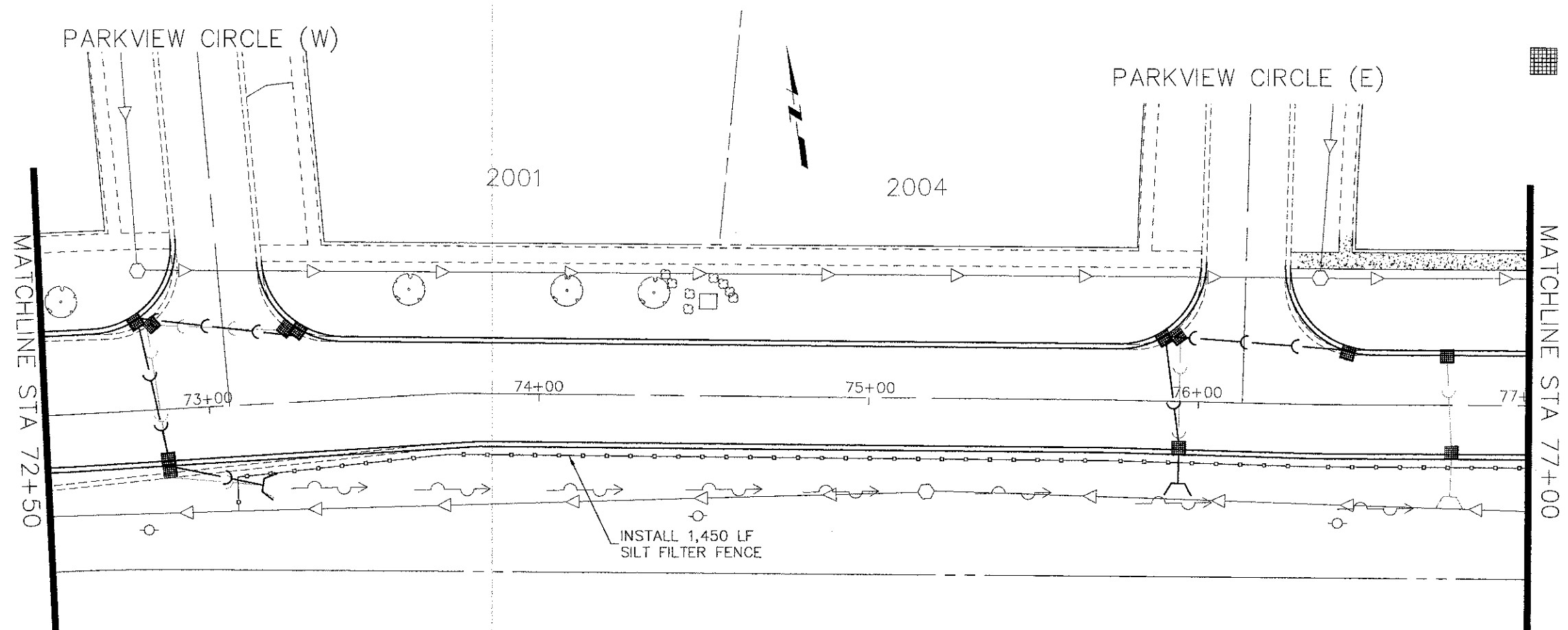

■ = 20 EACH

FILE NAME =
Hassell Plan-Profile.dwg

DESIGNED -	REVISIONS
DRAWN -	REVISIONS
CHECKED -	REVISIONS
DATE -	REVISIONS

**STATE OF ILLINOIS
DEPARTMENT OF TRANSPORTATION**

Hassell Road STP Project
Erosion Control Plan

SCALE: 1" = 20' SHEET NO. 7 OF 8 SHEETS STA. 68+00 TO STA 77+00

F.A.U. RTE.	SECTION	COUNTY	TOTAL SHEETS	SHEET NO.
1100	11-00087-00-FP	Cook	164	55
CONTRACT NO. 63770			ILLINOIS FED. AID PROJECT CMM 9003(757)	

PLAN	SURVEYED	DATE	BY
	PLOTTED		
	NOTED		
	REVISIONS		
	NO. _____		
	DATE _____		
	BY _____		
	NO. _____		
	DATE _____		
	BY _____		
	NO. _____		
	DATE _____		
	BY _____		

PROFILE	SURVEYED	DATE	BY
	PLOTTED		
	NOTED		
	REVISIONS		
	NO. _____		
	DATE _____		
	BY _____		
	NO. _____		
	DATE _____		
	BY _____		
	NO. _____		
	DATE _____		
	BY _____		

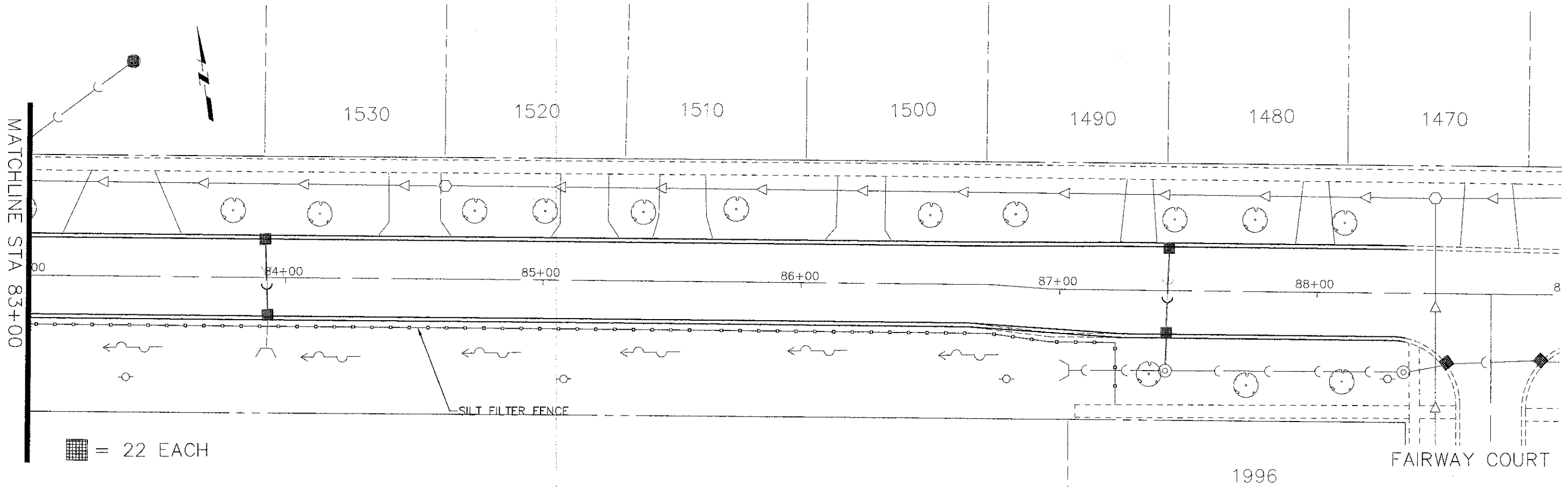
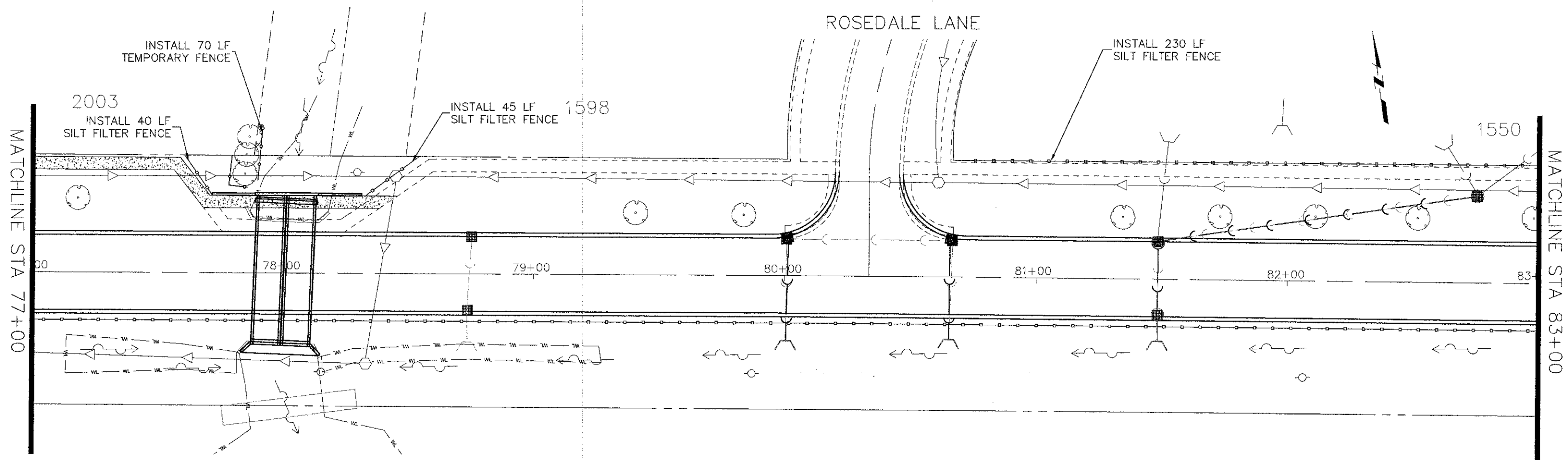

■ = 22 EACH

FILE NAME =	DESIGNED -	REVISED -
Hassell Plan-Profile.dwg	DRAWN -	REVISED -
	CHECKED -	REVISED -
	DATE -	REVISED -

STATE OF ILLINOIS
DEPARTMENT OF TRANSPORTATION

Hassell Road STP Project
Erosion Control Plan
SCALE: 1" = 20'
SHEET NO. 8 OF 8 SHEETS
STA. 77+00 TO STA 89+00

F.A.U. RIE	SECTION	COUNTY	TOTAL SHEETS	SHEET NO.
1100	11-00087-00-FP	Cook	164	56
CONTRACT NO. 63770			ILLINOIS FED. AID PROJECT CMM 9003(757)	

PLAN SURVEYED
 PLOTTED
 NOTE BOOK ALIGNED CHECKED
 NO. CAD FILE NAME

PROFILE SURVEYED
 PLOTTED
 NOTE BOOK GRADES CHECKED
 NO. STRUCTURE NOTATIONS OK'D

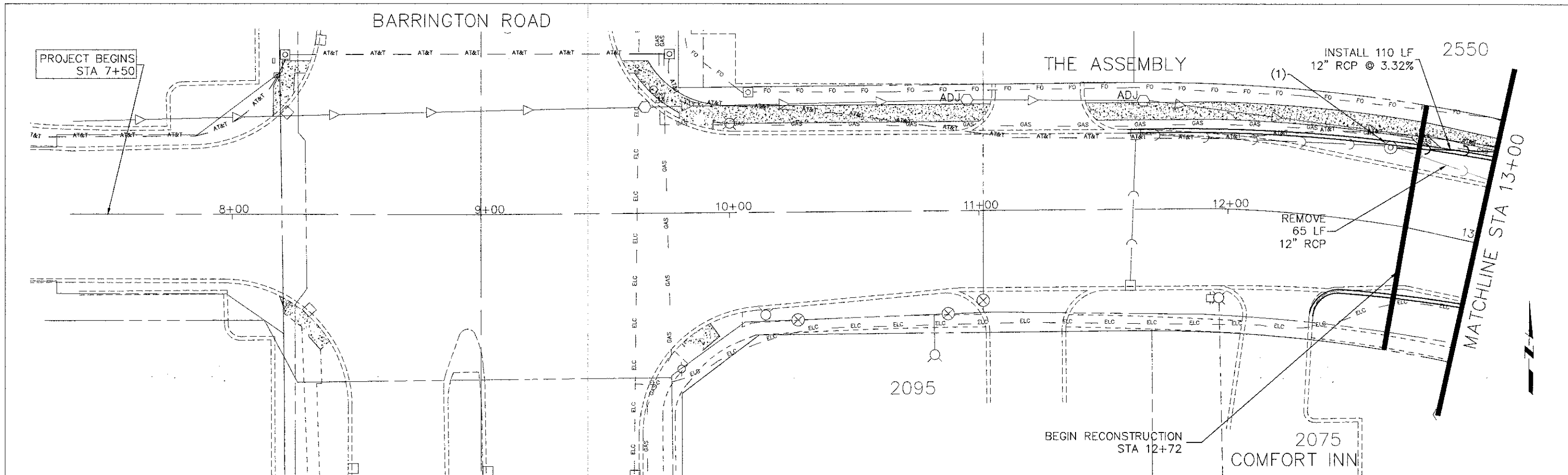

STRUCTURE NUMBER	STATION	OFFSET	RIM ELEV.	INVERT ELEV.	STRUCTURE TYPE
816	12+63	31.0' LT.	808.00	804.00 ESE, 804.20 W	ADJUST 4' MANHOLE W/NEW TYPE 23 FRAME & GRATE
814					
812					
810					
808					
806					
804					
802					
800					

FILE NAME = Hassell Plan-Profile.dwg	DESIGNED - DRAWN - CHECKED - DATE -	REVISED - REVISED - REVISED - REVISED -	<p align="center">STATE OF ILLINOIS DEPARTMENT OF TRANSPORTATION</p>	<p align="center">Hassell Road STP Project Drainage and Utilities</p>	F.A.U. RTE. 1100 SECTION 11-00087-00-FP COUNTY Cook TOTAL SHEETS 164 SHEETS NO. 57 CONTRACT NO. 63770 ILLINOIS FED. AID PROJECT CMM 9003(757)
---	--	--	--	--	---

SCALE: 1" = 20' SHEET NO. 1 OF 16 SHEETS STA. 8+00 TO STA 13+00

PLAN SURVEYED PLOTTED
 NOTE BOOK PLUMBER CHECKED
 NO. STRUCTURE NUMBER NAME

PROFILE SURVEYED PLOTTED
 NOTE BOOK PLUMBER CHECKED
 NO. STRUCTURE NUMBER NAME

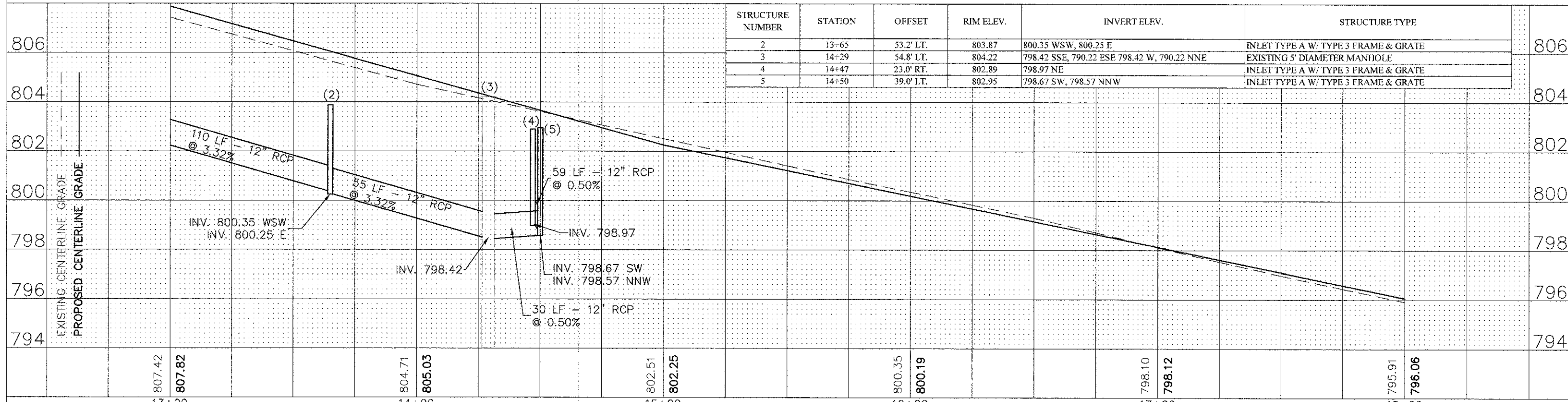
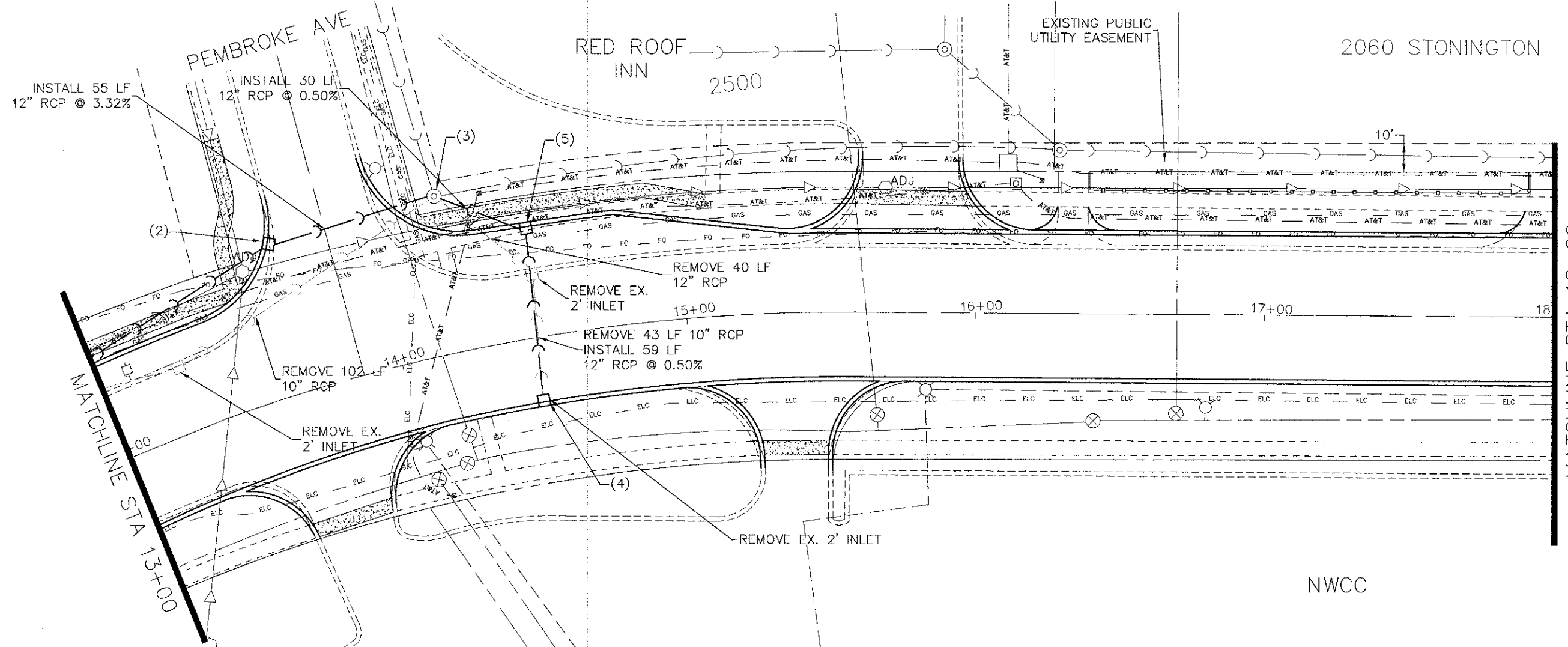

STRUCTURE NUMBER	STATION	OFFSET	RIM ELEV.	INVERT ELEV.	STRUCTURE TYPE
2	13+65	53.2' LT.	803.87	800.35 WSW, 800.25 E	INLET TYPE A W/ TYPE 3 FRAME & GRATE
3	14+29	54.8' LT.	804.22	798.42 SSE, 790.22 ESE 798.42 W, 790.22 NNE	EXISTING 5' DIAMETER MANHOLE
4	14+47	23.0' RT.	802.89	798.97 NE	INLET TYPE A W/ TYPE 3 FRAME & GRATE
5	14+50	39.0' LT.	802.95	798.67 SW, 798.57 NNW	INLET TYPE A W/ TYPE 3 FRAME & GRATE

PLAN SURVEYED
 PLOTTED
 CHECKED
 NOTE BOOK NO. []
 DATE []

PROFILE SURVEYED
 PLOTTED
 CHECKED
 NOTE BOOK NO. []
 DATE []

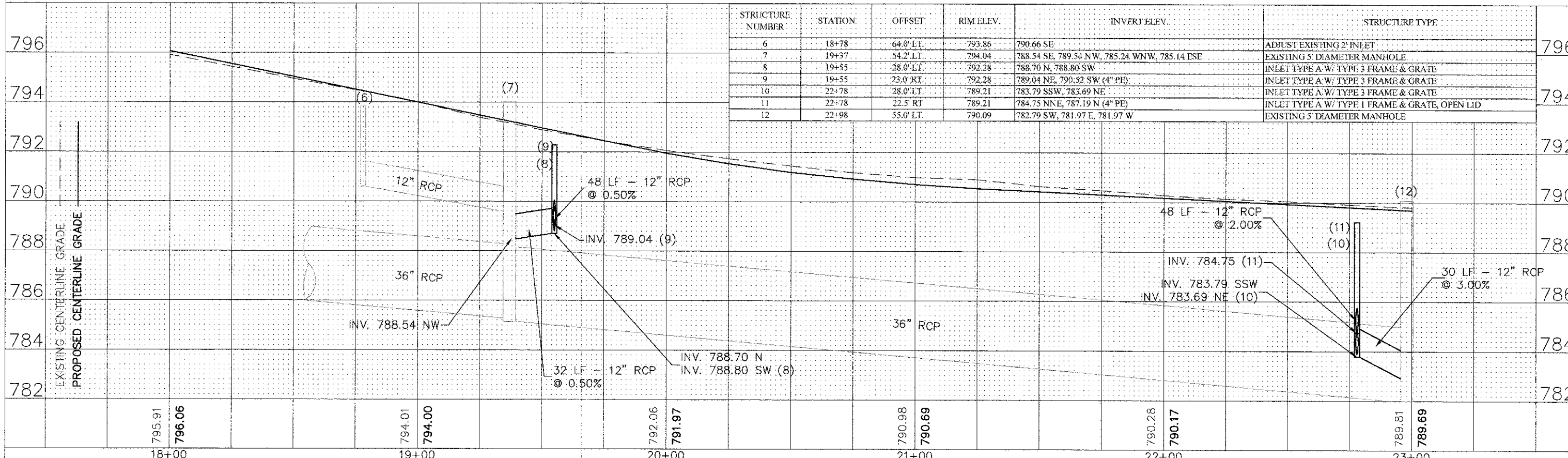
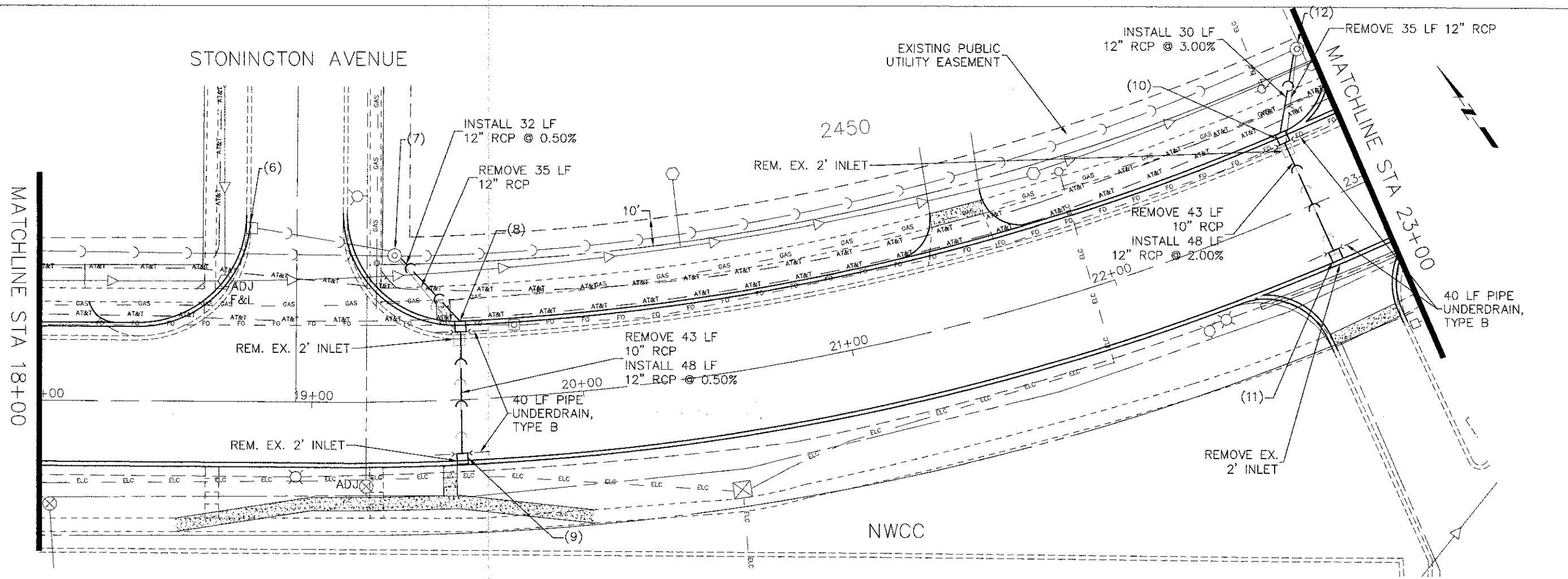

PLAN	SURVEYED	DATE	BY
	LIMITED		
	NOTED		
	CHECKED		
	BY		
	NO. OF PAGES CHECKED		
	NO.		
	SAMPLE NAME		

PROFILE	SURVEYED	DATE	BY
	LIMITED		
	NOTED		
	CHECKED		
	BY		
	NO. OF PAGES CHECKED		
	NO.		
	STRUCTURE NOTES CHECKED		

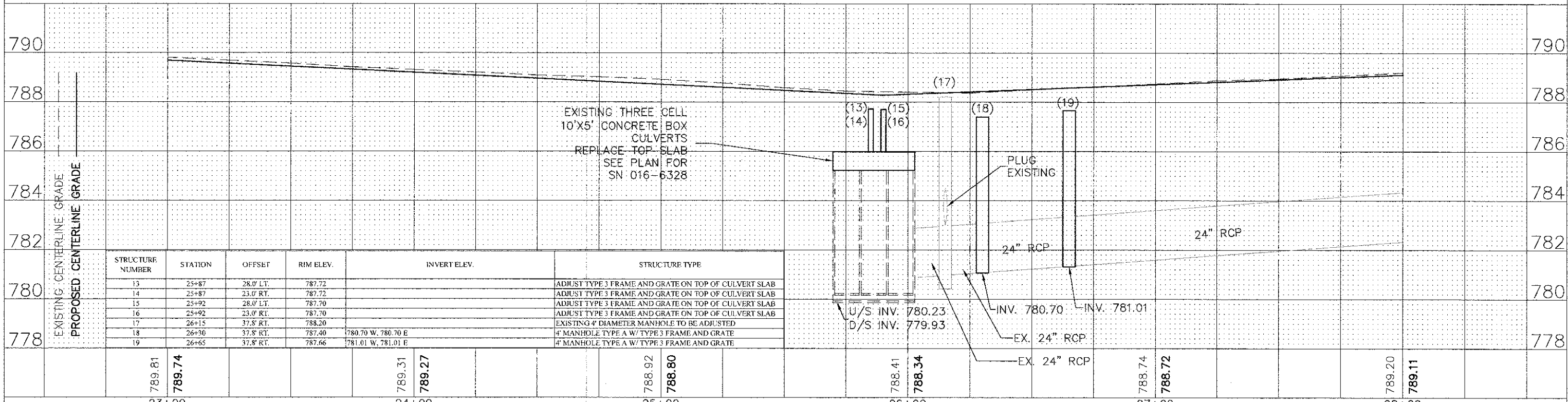
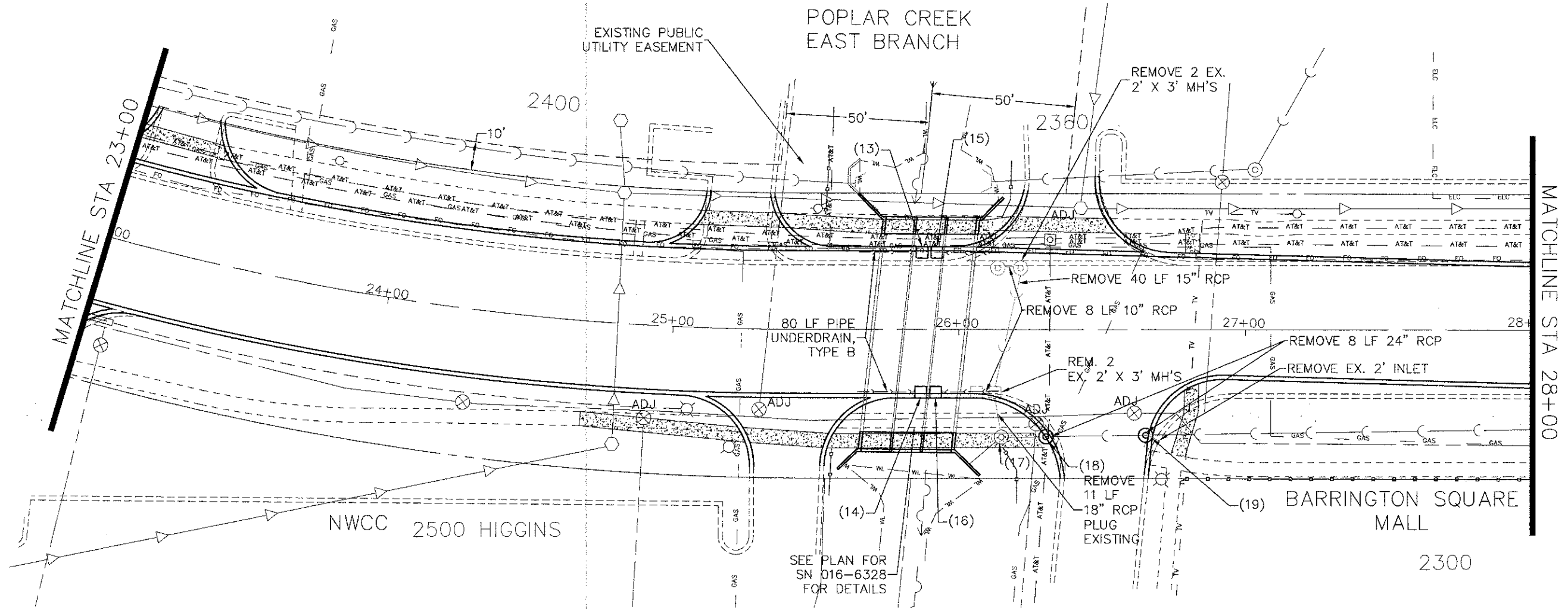

STRUCTURE NUMBER	STATION	OFFSET	RIM ELEV.	INVERT ELEV.	STRUCTURE TYPE
13	25+87	28.0' LT.	787.72		ADJUST TYPE 3 FRAME AND GRATE ON TOP OF CULVERT SLAB
14	25+87	23.0' RT.	787.72		ADJUST TYPE 3 FRAME AND GRATE ON TOP OF CULVERT SLAB
15	25+92	28.0' LT.	787.70		ADJUST TYPE 3 FRAME AND GRATE ON TOP OF CULVERT SLAB
16	25+92	23.0' RT.	787.70		ADJUST TYPE 3 FRAME AND GRATE ON TOP OF CULVERT SLAB
17	26+15	37.8' RT.	788.20		EXISTING 4' DIAMETER MANHOLE TO BE ADJUSTED
18	26+30	37.8' RT.	787.40	780.70 W, 780.70 E	4' MANHOLE TYPE A W/ TYPE 3 FRAME AND GRATE
19	26+65	37.8' RT.	787.66	781.01 W, 781.01 E	4' MANHOLE TYPE A W/ TYPE 3 FRAME AND GRATE

PLAN
 DRAWN BY: []
 CHECKED BY: []
 DATE: []
 NOTE BOOK ALIGNED CHECKED []
 PLAN NO. []

PROFILE
 DRAWN BY: []
 CHECKED BY: []
 DATE: []
 NOTE BOOK GRADES CHECKED []
 PROFILE NO. []

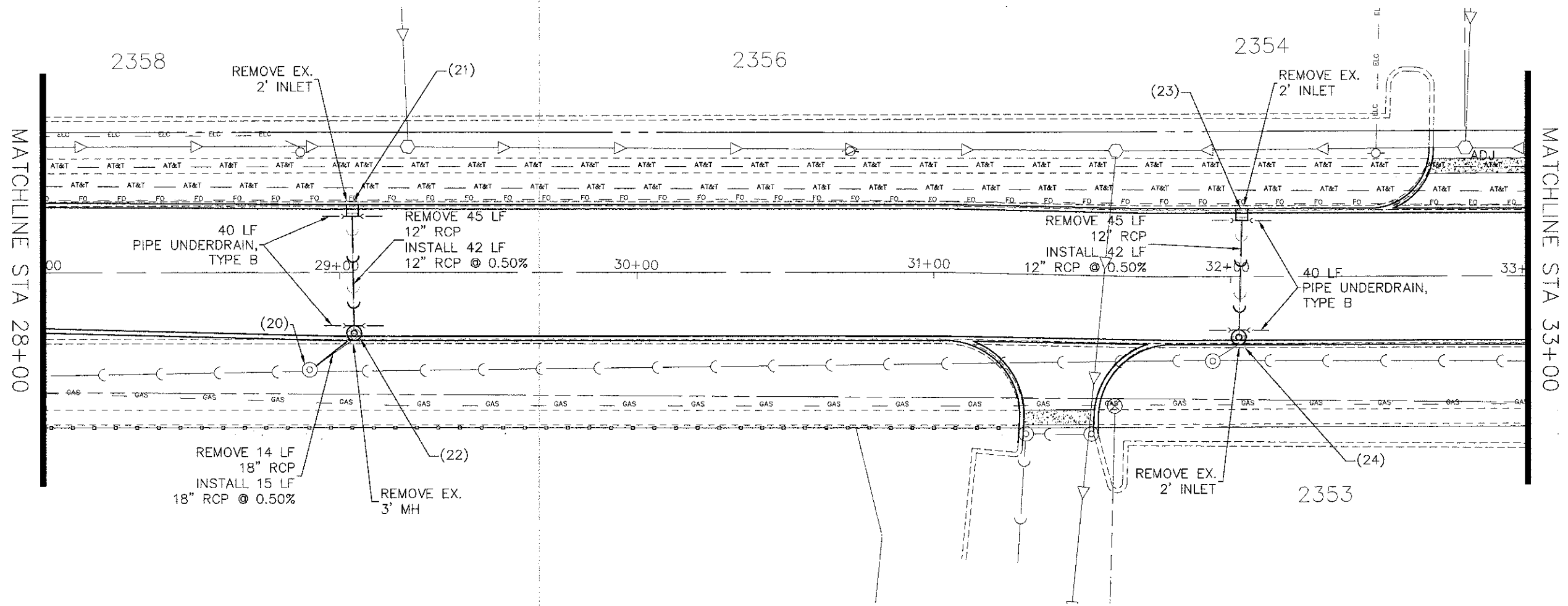

STRUCTURE NUMBER	STATION	OFFSET	RIM ELEV.	INVERT ELEV.	STRUCTURE TYPE	
796	20	28+91	32.8' RT.	789.20	784.05 NE, 783.20 E, 783.00 W	EXISTING 4' DIAMETER MANHOLE
	21	29+05	22.0' LT.	789.02	784.84 S	INLET TYPE A W/ TYPE 3 FRAME & GRATE
	22	29+05	22.0' RT.	789.02	784.63 N, 784.13 SW	4' MANHOLE TYPE A W/ TYPE 3 FRAME AND GRATE
	23	32+04	22.0' LT.	791.88	787.99 S	INLET TYPE A W/ TYPE 3 FRAME & GRATE
	24	32+04	22.0' RT.	791.88	787.78 N, 787.43 SW	4' MANHOLE TYPE A W/ TYPE 3 FRAME AND GRATE

STATION	INVERT ELEV.	PIPE TYPE	LENGTH	PERCENT
28+00	789.20	15 LF - 18" RCP		0.50%
29+00	789.51	42 LF - 12" RCP		0.50%
30+00	789.90	21" RCP		
31+00	790.68	42 LF - 12" RCP		0.50%
32+00	792.31	18" RCP		
33+00	794.33	42 LF - 12" RCP		0.50%

PLAN
 REVISIONS
 NO. DATE
 NOTE BOOK ALIGNMENT CHECKED
 NO. DATE
 NOTE BOOK GRADES CHECKED
 NO. DATE
 NOTE BOOK STRUCTURE NOTATIONS CHECKED
 NO. DATE

PROFILE
 REVISIONS
 NO. DATE
 NOTE BOOK GRADES CHECKED
 NO. DATE
 NOTE BOOK STRUCTURE NOTATIONS CHECKED
 NO. DATE

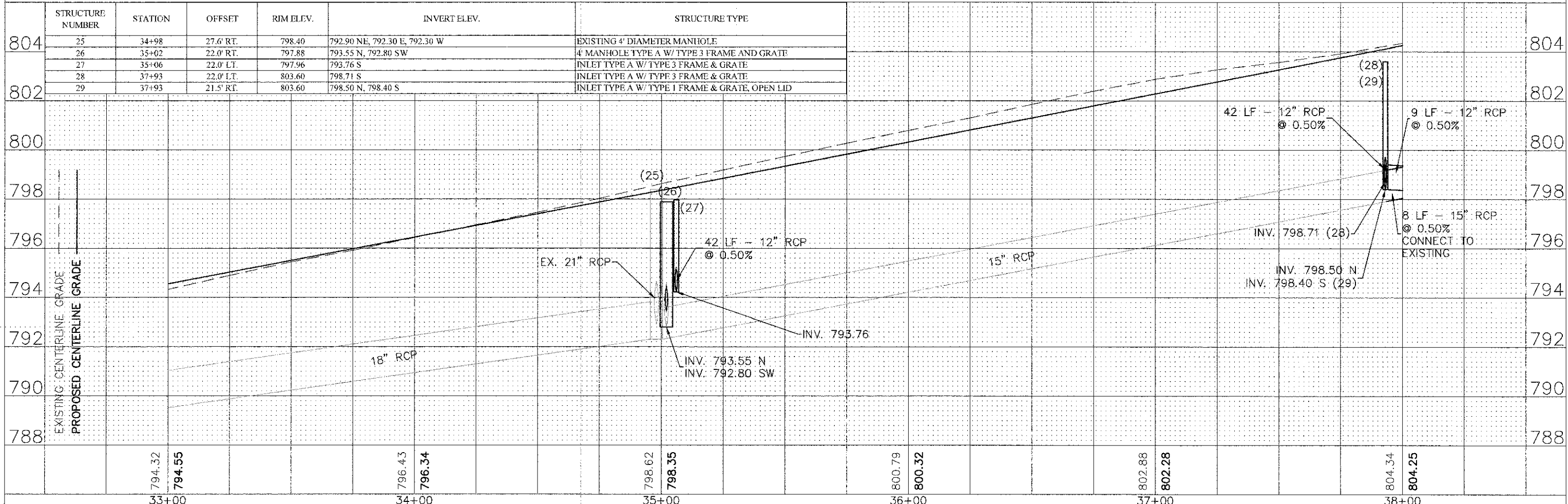
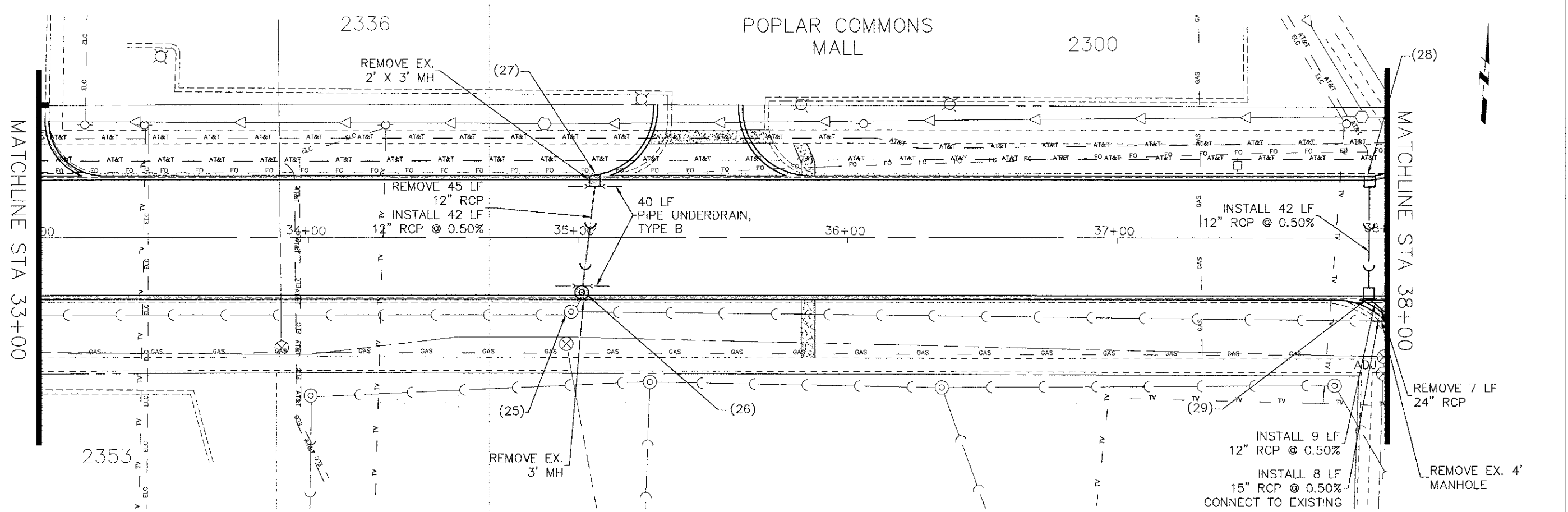

PLAN
 SURVEYED
 NOTE BOOK ALIGNED CHECKED
 NO. OF WAY CHECKED
 DATE

PROFILE
 GRADES CHECKED
 NOTE BOOK GRADES CHECKED
 NO. OF STRUCTURE NOTATIONS CHECKED
 DATE

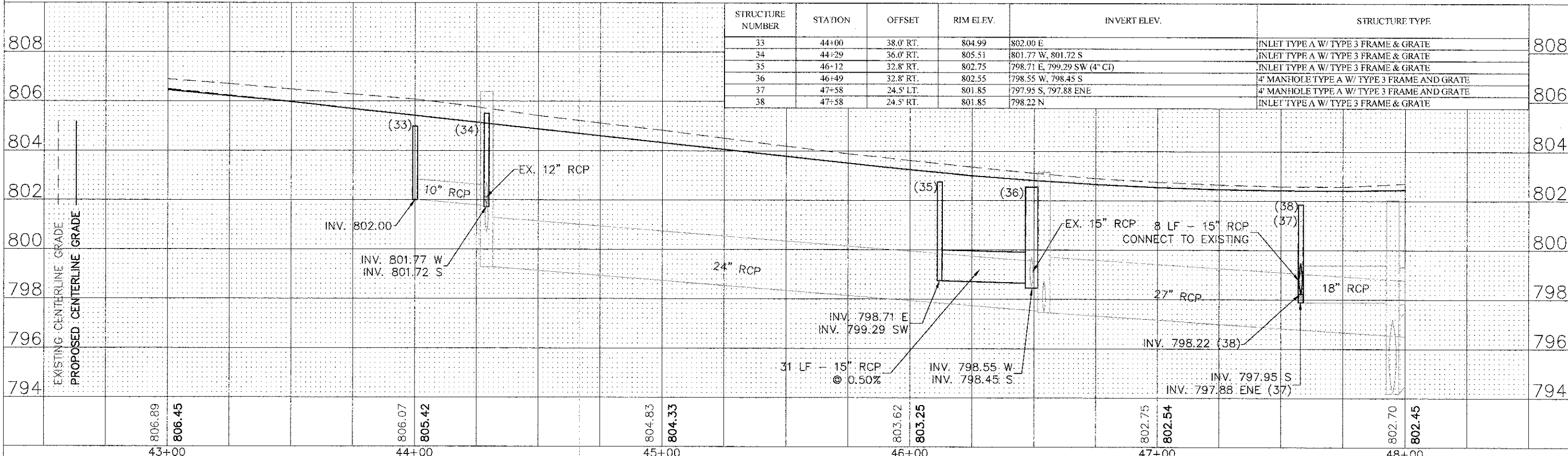
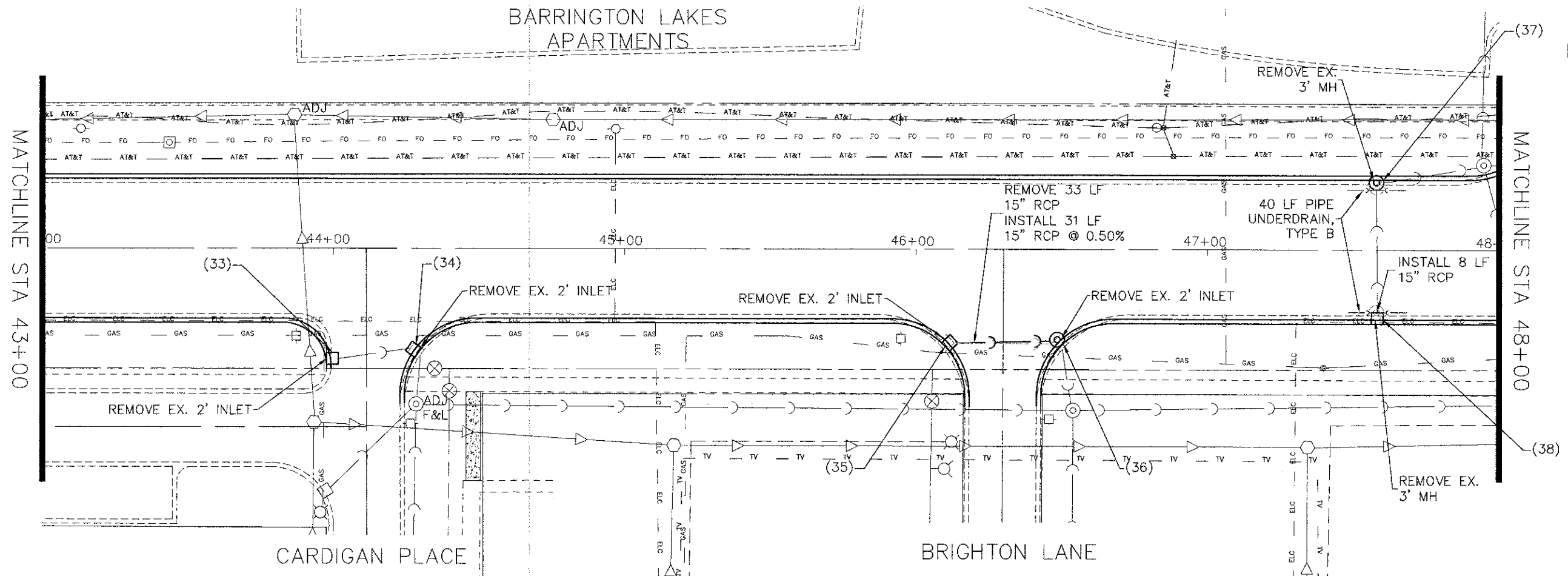

STRUCTURE NUMBER	STATION	OFFSET	RIM ELEV.	INVERT ELEV.	STRUCTURE TYPE
33	44+00	38.0' RT.	804.99	802.00 E	INLET TYPE A W/ TYPE 3 FRAME & GRATE
34	44+29	36.0' RT.	805.51	801.77 W, 801.72 S	INLET TYPE A W/ TYPE 3 FRAME & GRATE
35	46+12	32.8' RT.	802.75	798.71 E, 799.29 SW (4\"/>	

PLAN	SURVEYED	DATE	BY
	NOTE BOOK		
	ALIGNMENT CHECKED		
	BY		
	NO.		
	NO.		
	NO.		

PROFILE	SURVEYED	DATE	BY
	NOTE BOOK		
	GRADES CHECKED		
	BY		
	NO.		
	NO.		
	NO.		

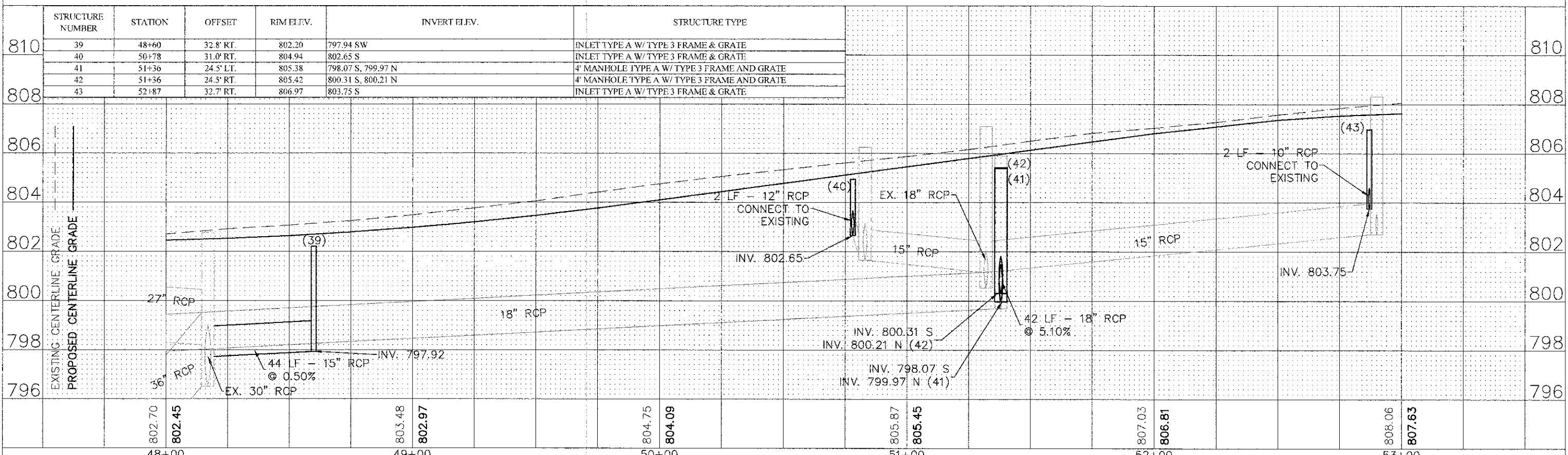
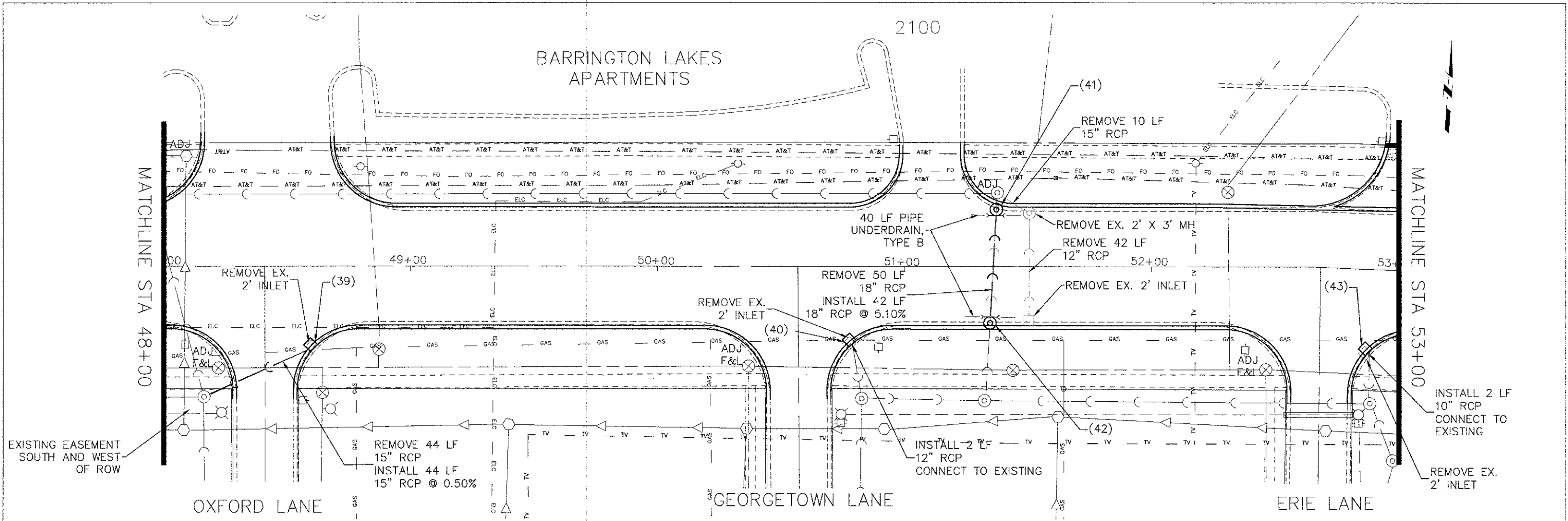

FILE NAME = Hassell Plan-Profile.dwg	DESIGNED -	REVISIONS	STATE OF ILLINOIS DEPARTMENT OF TRANSPORTATION	Hassell Road STP Project Drainage and Utilities	F.A.U. RTE. 1100	SECTION 11-00087-00-FP	COUNTY Cook	TOTAL SHEETS 164	SHEET NO. 65	CONTRACT NO. 63770	ILLINOIS FED. AID PROJECT CMM 9003(757)
---	------------	-----------	---	--	------------------	------------------------	-------------	------------------	--------------	--------------------	---

PLAN SURVEYED
 PLOTTED
 NOTE BOOK ALIGNED CHECKED
 NO. _____ DATE _____
 SURVEYOR'S NAME _____

PROFILE SURVEYED
 PLOTTED
 NOTE BOOK CHECKED
 NO. _____ DATE _____
 STRUCTURE NOTATIONS OK'G

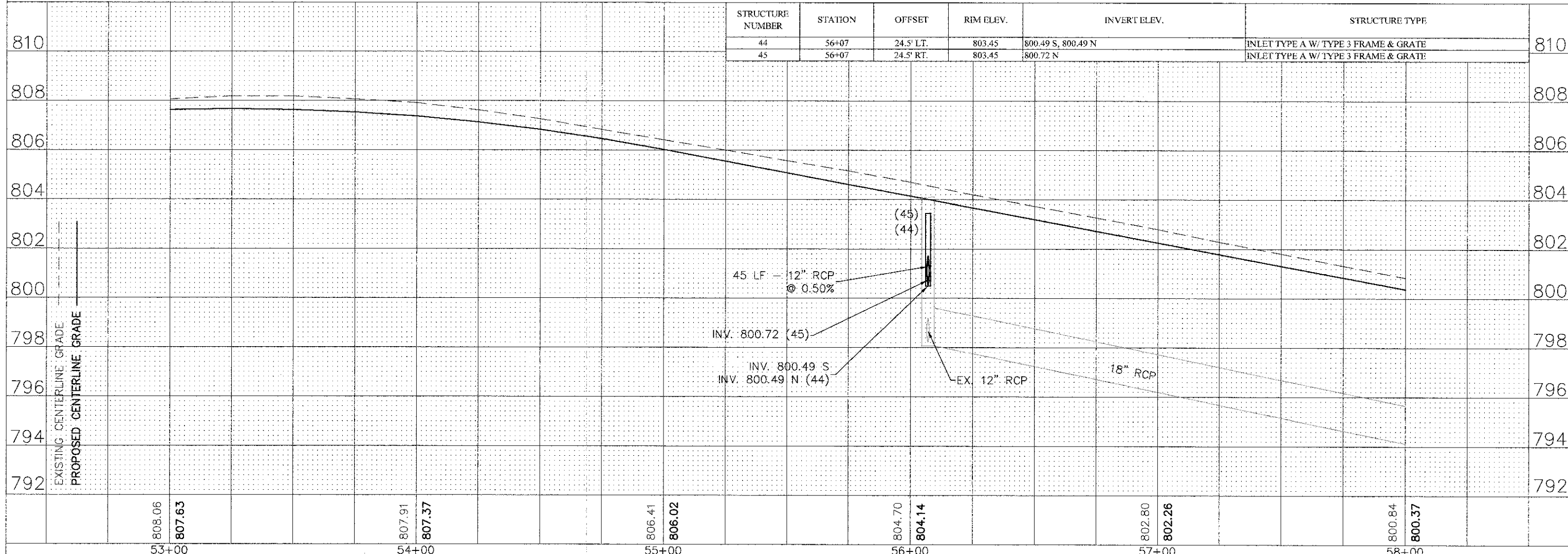
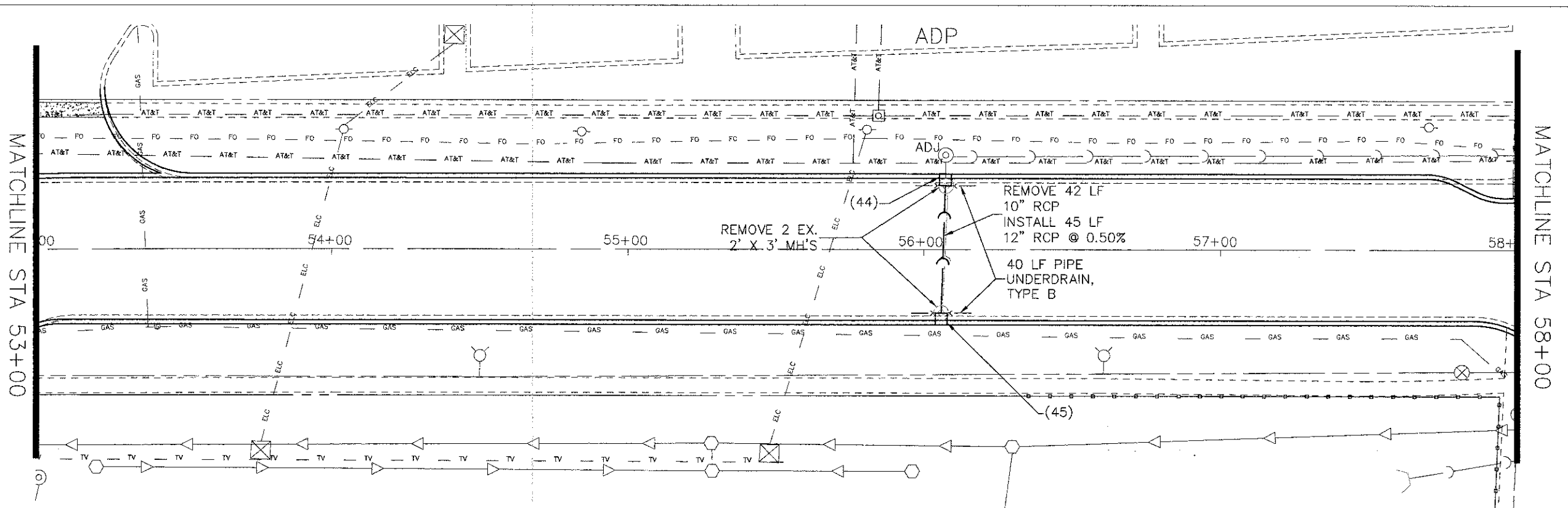

STRUCTURE NUMBER	STATION	OFFSET	RIM ELEV.	INVERT ELEV.	STRUCTURE TYPE
44	56+07	24.5' LT.	803.45	800.49 S, 800.49 N	INLET TYPE A W/ TYPE 3 FRAME & GRATE
45	56+07	24.5' RT.	803.45	800.72 N	INLET TYPE A W/ TYPE 3 FRAME & GRATE

PLAN
 REVISIONS
 DATE
 BY
 NO. 1
 NO. 2
 NO. 3
 NO. 4
 NO. 5
 NO. 6
 NO. 7
 NO. 8
 NO. 9
 NO. 10
 NOTE BOOK
 ALIGNMENT CHECKED
 GRADES CHECKED
 STRUCTURE NOTATIONS OK'D
 DATE
 BY
 NO.

PROFILE
 REVISIONS
 DATE
 BY
 NO. 1
 NO. 2
 NO. 3
 NO. 4
 NO. 5
 NO. 6
 NO. 7
 NO. 8
 NO. 9
 NO. 10
 NOTE BOOK
 GRADES CHECKED
 STRUCTURE NOTATIONS OK'D
 DATE
 BY
 NO.

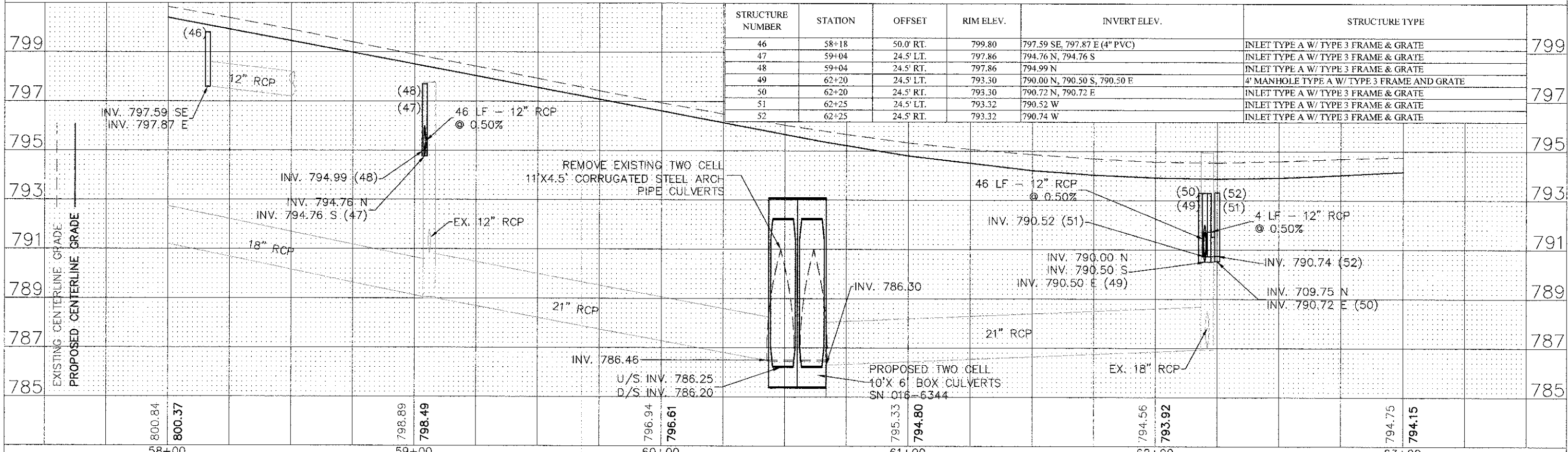
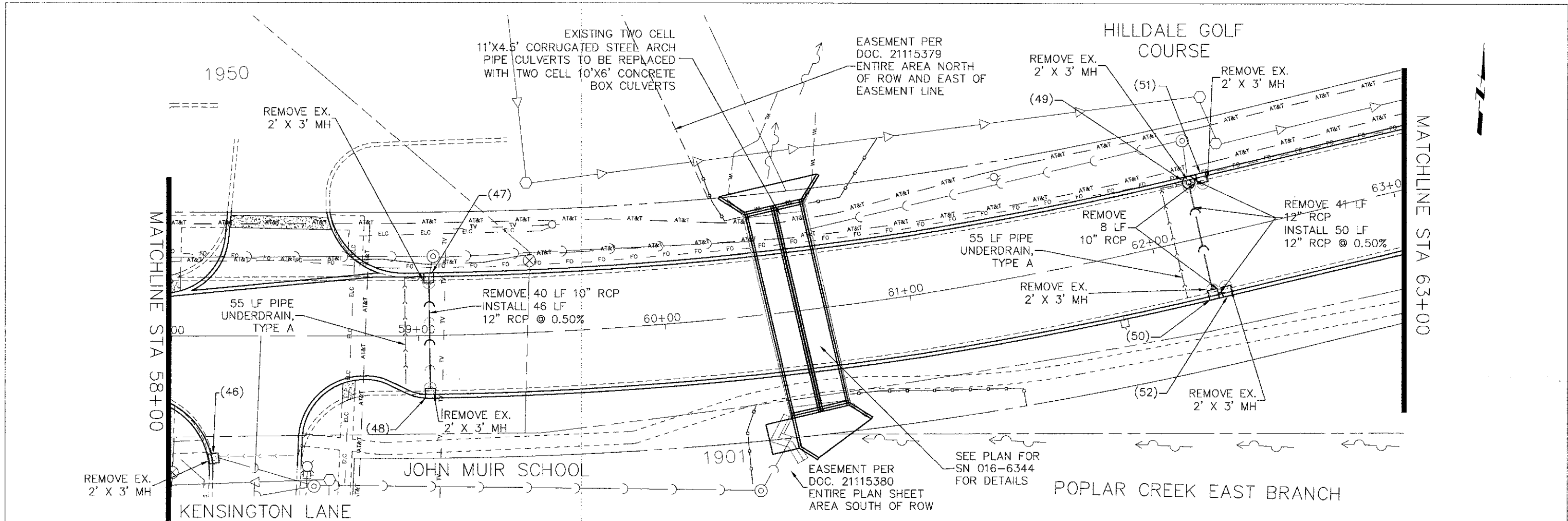

PLAN	SURVEYED
	LOTTREY
	NOTE BOOK NO.
	RT. OF WAY CHECKED
	NO.
	CADRELL NAME

PROFILE	DATE	BY

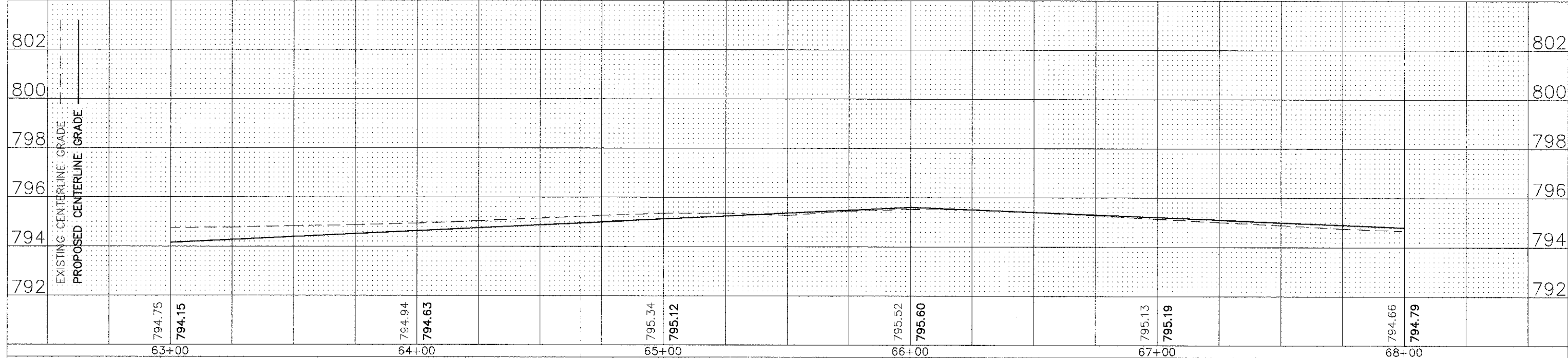
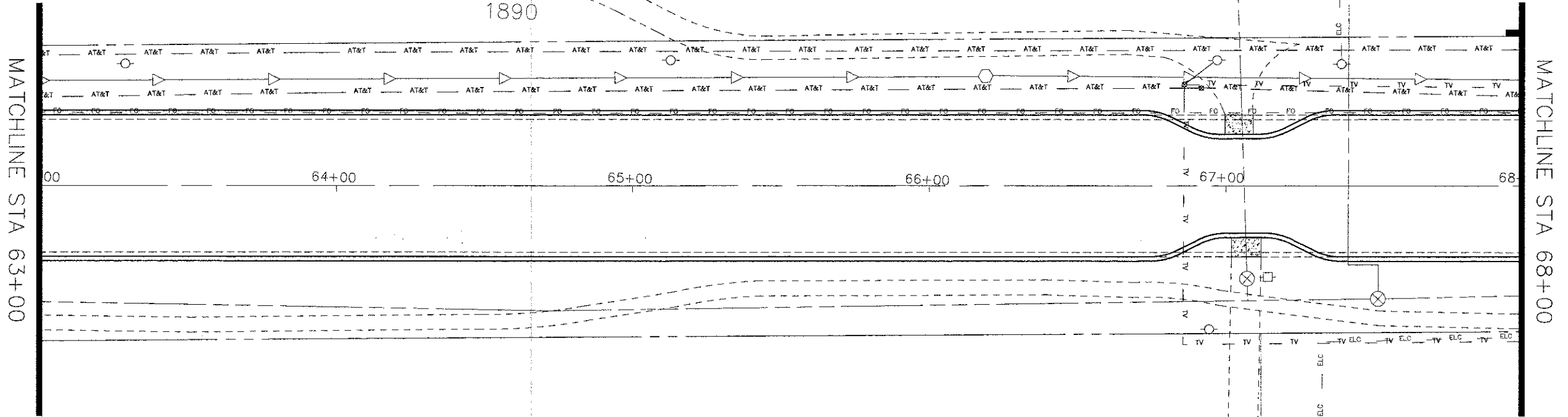

FILE NAME: Hassell Plan-Profile.dwg

DESIGNED -	REVISIONS
DRAWN -	REVISIONS
CHECKED -	REVISIONS
DATE -	REVISIONS

**STATE OF ILLINOIS
DEPARTMENT OF TRANSPORTATION**

Hassell Road STP Project
Drainage and Utilities

F.A.U. RTE.	SECTION	COUNTY	TOTAL SHEETS	SHEET NO.
1100	11-00087-00-FP	Cook	160	68
CONTRACT NO. 63770			ILLINOIS FED. AID PROJECT CMM 9003(757)	

SCALE: 1" = 20' SHEET NO. 12 OF 16 SHEETS STA. 63+00 TO STA 68+00

PLAN
 DESIGNED -
 CHECKED -
 DATE -
 BY -
 DATE -
 PROFILE
 DESIGNED -
 CHECKED -
 DATE -
 BY -
 DATE -

PROFILE
 DESIGNED -
 CHECKED -
 DATE -
 BY -
 DATE -

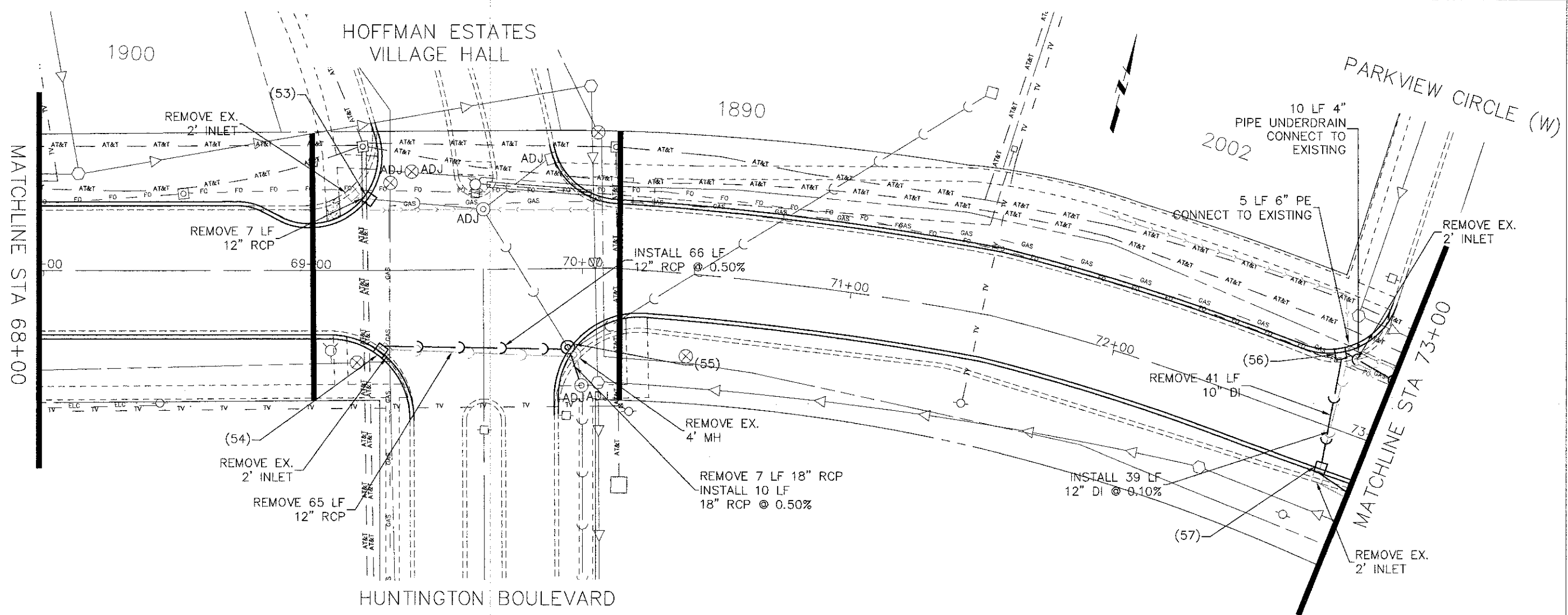

STRUCTURE NUMBER	STATION	OFFSET	RIM ELEV.	INVERT ELEV.	STRUCTURE TYPE
798	69-20	26.5' LT.	793.11	790.71 NE	INLET TYPE A RE-USE EXISTING FRAME & GRATE
798	69-26	30.0' RT.	793.40	789.88 E	INLET TYPE A W/ TYPE 3 FRAME & GRATE
796	69-95	29.3' RT.	793.30	789.55 NW, 789.55 W, 789.02 S, 789.05 NE	4' MANHOLE TYPE A W/ TYPE 3 FRAME AND GRATE
796	72-80	27.4' LT.	793.66	791.67 E, 791.67 S, 791.85 NE (4" PVC), 791.95 NW (6" PE)	INLET TYPE A W/ TYPE 3 FRAME & GRATE
796	72-87	16.3' RT.	794.34	791.50 N, 791.40 ESE	INLET TYPE A W/ TYPE 3 FRAME & GRATE

STATION	EXISTING CENTERLINE GRADE	PROPOSED CENTERLINE GRADE
68+00	794.66	794.79
69+00	794.63	794.38
70+00	794.51	794.04
71+00	795.04	794.76
72+00	795.26	795.20
73+00	794.61	794.80

PARKVIEW CIRCLE (W)

PARKVIEW CIRCLE (E)

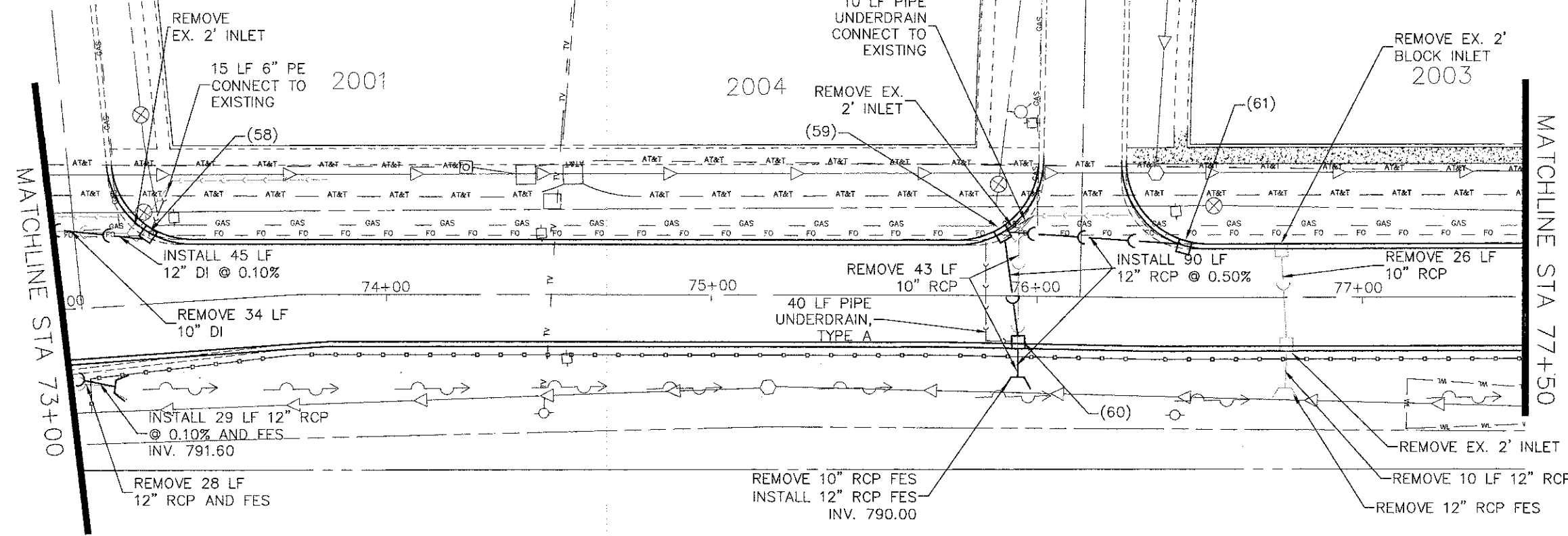

GRADE AND SHAPE DITCH
STA 75+00R - STA 77+50R

STRUCTURE NUMBER	STATION	OFFSET	RIM ELEV.	INVERT ELEV.	STRUCTURE TYPE
58	73+28	21.5' LT.	793.69	791.72 W, 791.96 NNE (6" PE)	INLET TYPE A W/ TYPE 3 FRAME & GRATE
59	75+91	19.8' LT.	793.29	791.43 N (4" PVC), 790.40 E, 790.30 S	INLET TYPE A W/ TYPE 3 FRAME & GRATE
60	75+94	15.5' RT.	793.23	790.14 N, 790.04 S	INLET TYPE A W/ TYPE 3 FRAME & GRATE
61	76+45	16.5' LT.	793.62	790.66 W	INLET TYPE A W/ TYPE 3 FRAME & GRATE

STATION	INVERT ELEV.	STRUCTURE TYPE
73+00	794.61	
74+00	794.80	
75+00	794.93	
76+00	794.66	
77+00	794.23	

PLAN SURVEYED
ALIGNED
NOTE BOOK NO.
CHECKED
DATE

PROFILE SURVEYED
PLOTTED
NOTE BOOK NO.
CHECKED
DATE

PLAN
 SURVEYED
 NOTE BOOK ALIGNED CHECKED
 RT. OF WAY CHECKED
 NO. SAMPLE NAME

PROFILE
 SURVEYED
 NOTE BOOK GRADES CHECKED
 E.M. NOTED
 STRUCTURE NOTING CH/VD
 NO.

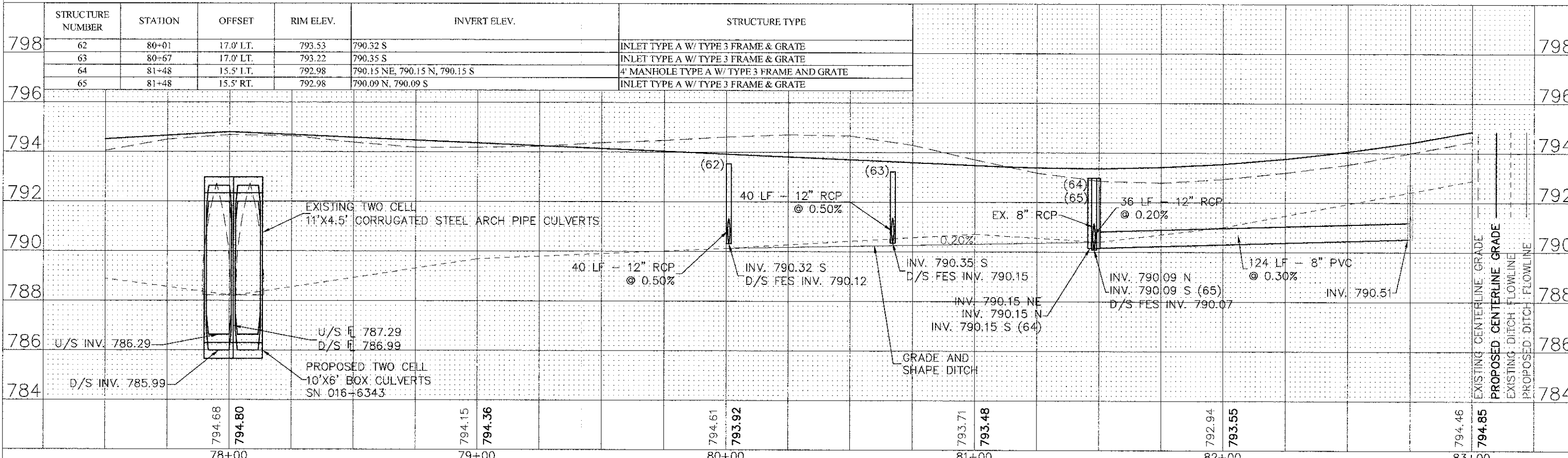
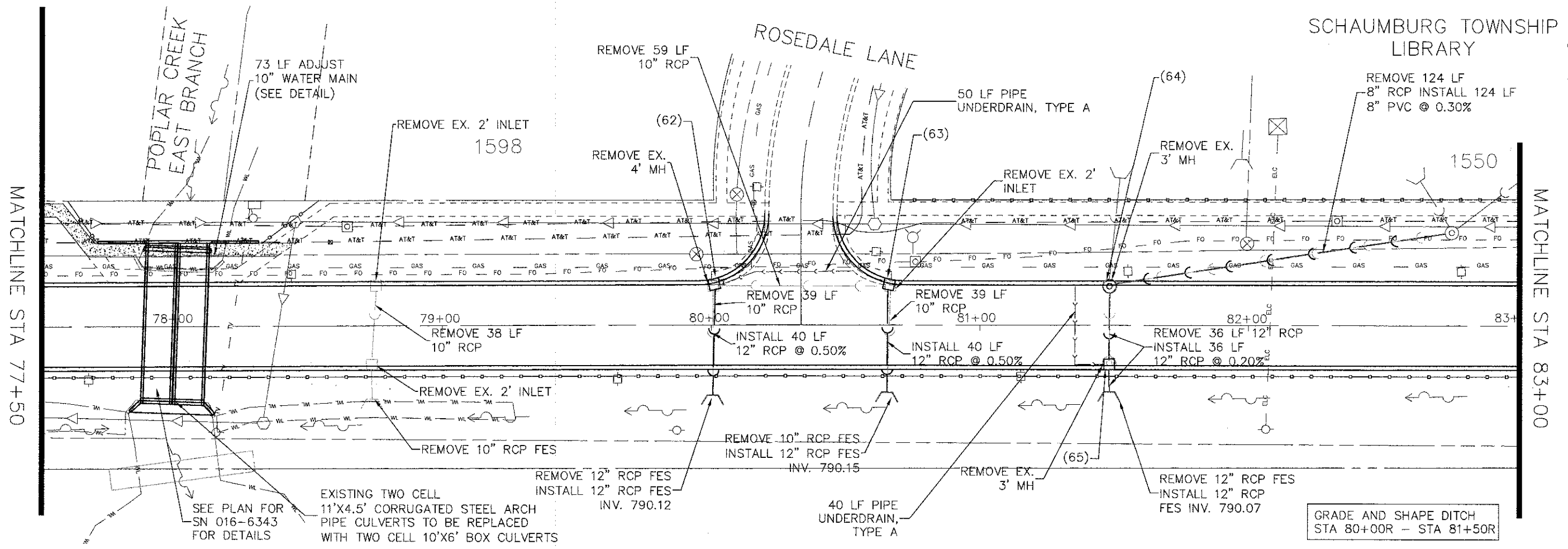

STRUCTURE NUMBER	STATION	OFFSET	RIM ELEV.	INVERT ELEV.	STRUCTURE TYPE
798	80+01	17.0' LT.	793.53	790.32 S	INLET TYPE A W/ TYPE 3 FRAME & GRATE
	80+67	17.0' LT.	793.22	790.35 S	INLET TYPE A W/ TYPE 3 FRAME & GRATE
	81+48	15.5' I.T.	792.98	790.15 NE, 790.15 N, 790.15 S	4' MANHOLE TYPE A W/ TYPE 3 FRAME AND GRATE
796	81+48	15.5' RT.	792.98	790.09 N, 790.09 S	INLET TYPE A W/ TYPE 3 FRAME & GRATE

PLAN	SURVEYED	DATE
	PLOTTED	BY
	NOTE BOOK	NO.
	ALIGNMENT CHECKED	
	CAUTION NAME	

PROFILE	SURVEYED	DATE
	PLOTTED	BY
	NOTE BOOK	NO.
	GRADES CHECKED	
	STRUCTURE NOTATIONS OK'D	

MATCHLINE STA 83+00

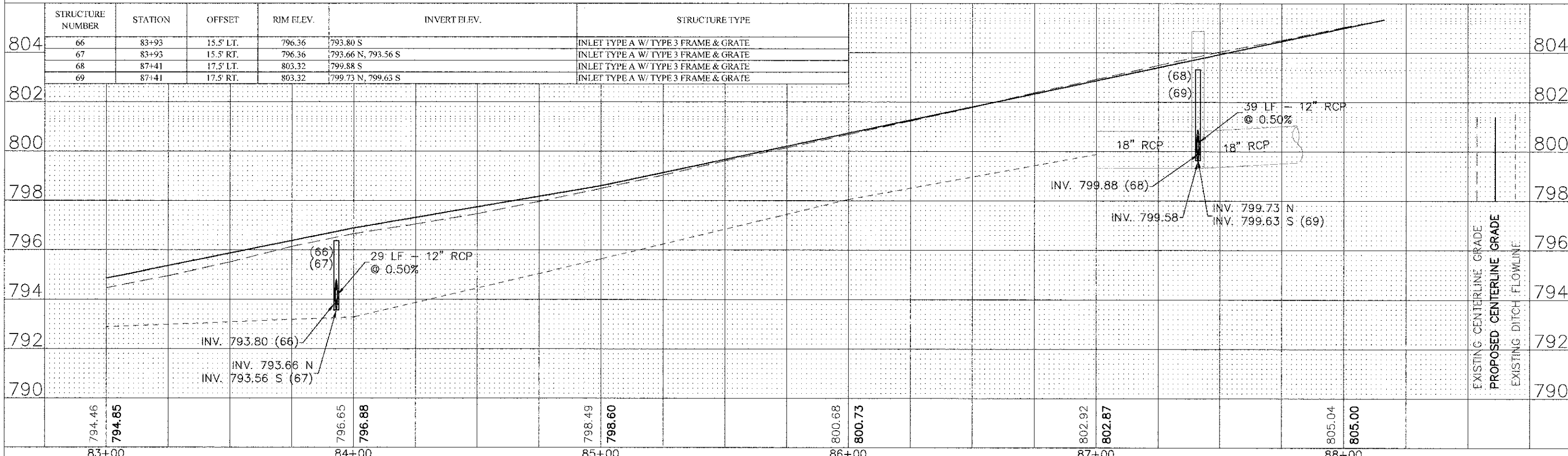
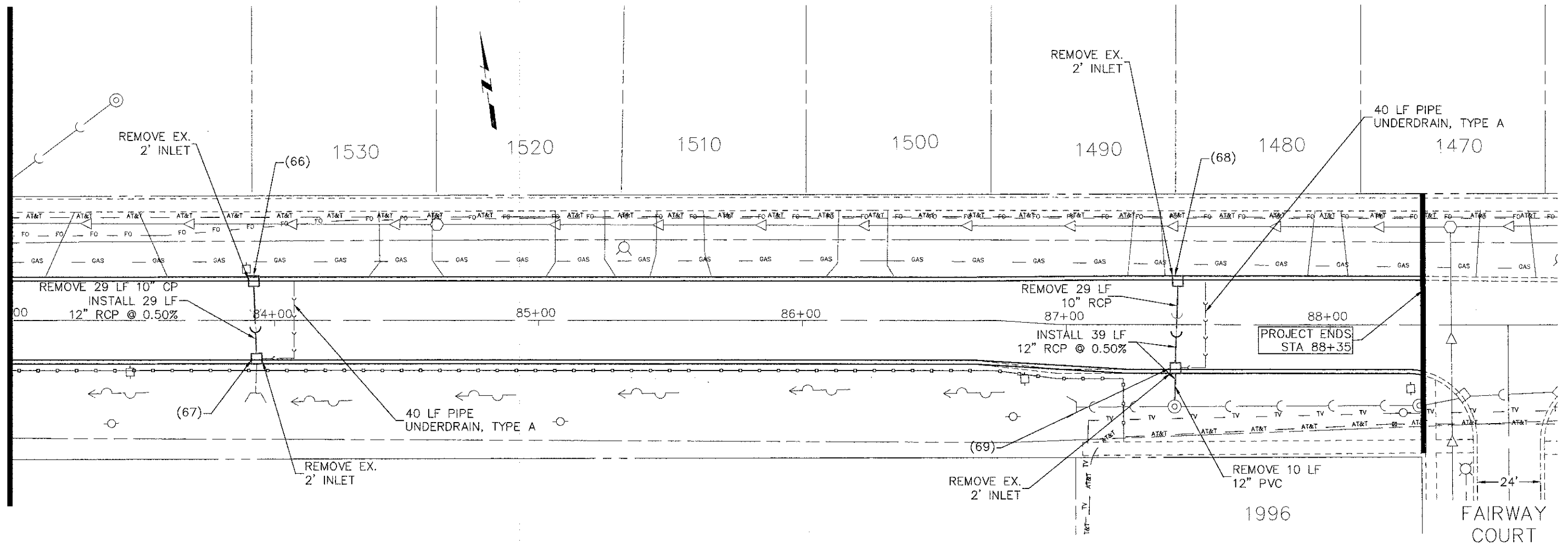

FILE NAME = Hassell Plan-Profile.dwg	DESIGNED -	REVISED -	STATE OF ILLINOIS DEPARTMENT OF TRANSPORTATION	Hassell Road STP Project Drainage and Utilities		F.A.U. RTE. 1100	SECTION 11-00087-00-FP	COUNTY Cook	TOTAL SHEETS 160	SHEET NO. 72
	DRAWN -	REVISED -		SCALE: 1" = 20'	SHEET NO. 16 OF 16 SHEETS	STA. 83+00 TO STA 89+00	CONTRACT NO. 63770		ILLINOIS FED. AID PROJECT CMM 9003(757)	
	CHECKED -	REVISED -								
	DATE -	REVISED -								

BARRINGTON ROAD

ALL STRIPING ON PCC SURFACE SHALL BE PAINT

NUMBER	LOCATION	MOUNT	EXISTING/PROPOSED	DESCRIPTION	PRIMARY SIGN			EXISTING/PROPOSED	DESCRIPTION	SECONDARY SIGN		
					MUTCD	W	H			MUTCD	W	H
1	9+72R	SIGNAL POST	PROPOSED	STOP HERE FOR PEDS	R1-5B	36	36					
2	10+85R	NEW POST	PROPOSED	BICYCLE	W11-1	30	30	PROPOSED	SHARE THE ROAD	W16-1P	18	24
3	11+58L	EX. POST	RELOCATE	DO NOT BLOCK DRIVEWAY	R10-7	30	24					
4	11+95R	EX. LIGHT POLE	MAINTAIN EXISTING	SPEED LIMIT 30	R2-1	30	36	MAINTAIN EXISTING	WHIGHT LIMIT 5 TONS	R12-1	30	24
5	12+68R	NEW POST	PROPOSED	BEGINS	R3-9cP	30	12	PROPOSED	TWO-WAY LEFT TURN ONLY	R3-9b	24	36
6	13-12L	EX. POST	RELOCATE	RIGHT LANE MUST TURN RIGHT	R3-7R	30	30	PROPOSED	BIKE USE SIGNAL TO X BARRINGTON		24	18
7	13+66L	EX. POST	RELOCATE	STOP	R1-1	30	30					
8	13+98R	EX. LIGHT POLE	MAINTAIN EXISTING	NO OUTSIDE WATER USE		24	18	MAINTAIN EXISTING	NO PARKING MORE THAN 72 HOURS	R8-3M	24	18
9	14+14L	EX. POST	RELOCATE	PEMBROKE AVENUE		48	9	RELOCATE	HASSELL ROAD		42	9
10	14+91R	NEW POST	PROPOSED	BIKE ROUTE	D11-1	24	18	PROPOSED	VILLAGE HALL 1	D1-2C	30	6
								PROPOSED	TRIPHAWN CENTER 1.7	D1-2C	30	6
								PROPOSED	ROSELLE RD TRL 3.5	D1-2C	30	6
11	15+11L	EX. POST	RELOCATE	SPEED LIMIT 30	R2-1	30	24	RELOCATE	DO NOT BLOCK INTERSECTION	R10-7	30	24
12	15+81R	EX. LIGHT POLE	MAINTAIN EXISTING	SPEED LIMIT 30	R2-1	30	24	PROPOSED	BICYCLE	W11-1	30	30
									SHARE THE ROAD	W16-1P	18	24
13	16+90L	EX. POST	RELOCATE	SIGNAL AHEAD	W3-3	30	30	PROPOSED	POPLAR CREEK TRL 0.4	D1-2C	30	6

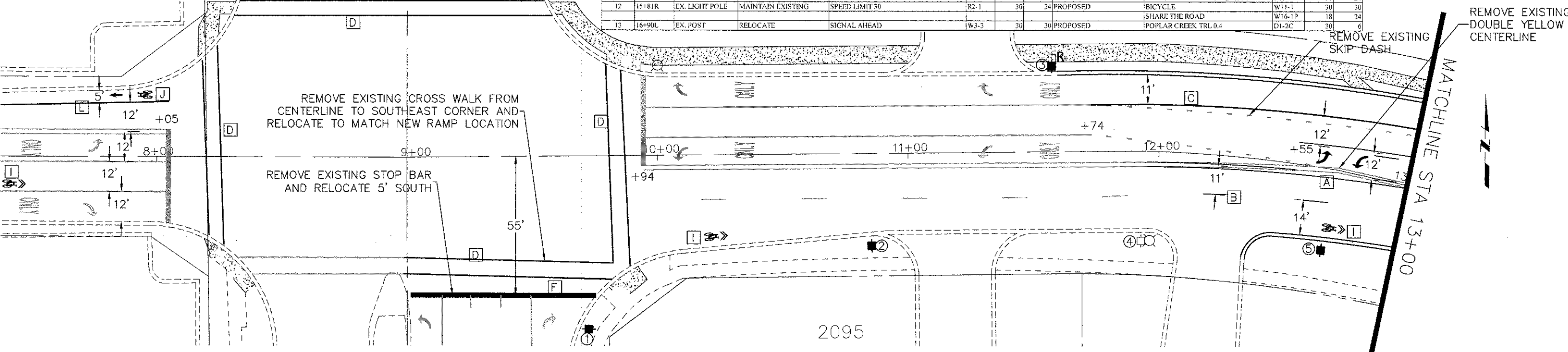

PEMBROKE AVENUE

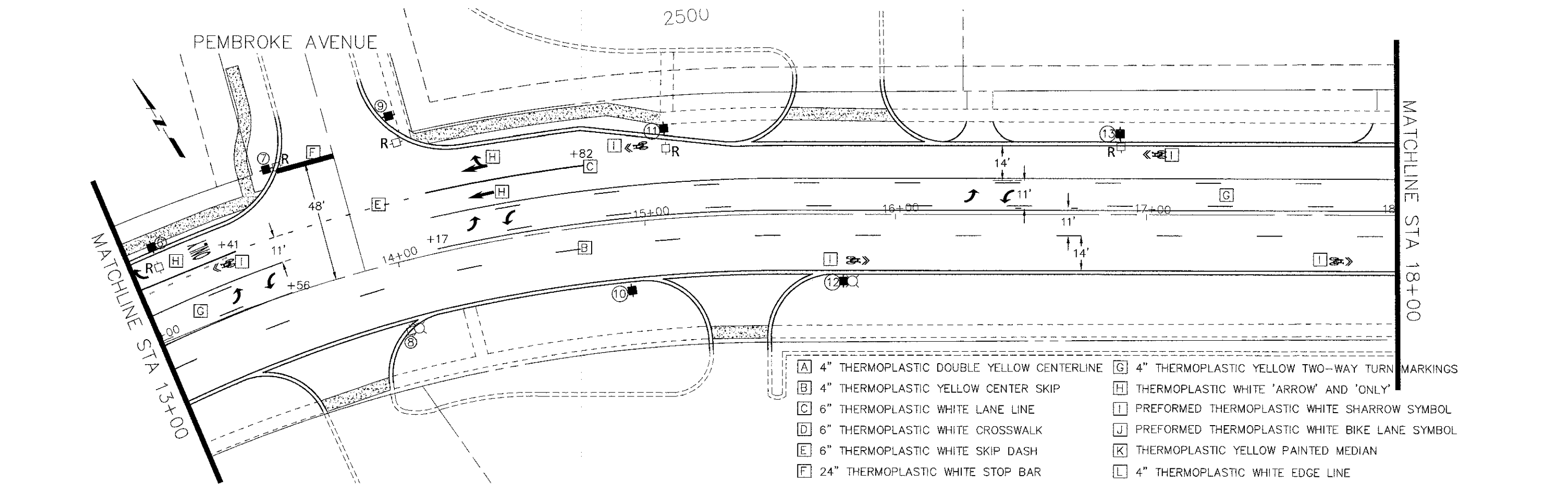

PLAN	DESIGNED	DATE
	DRAWN	
	CHECKED	
	DATE	

PROFILE	DESIGNED	DATE
	DRAWN	
	CHECKED	
	DATE	

STATE OF ILLINOIS
DEPARTMENT OF TRANSPORTATION

Hassell Road STP Project
Striping and Signage Plan

SCALE: 1" = 20' SHEET NO. 1 OF 9 SHEETS STA. 9+00 TO STA 18+00

F.A.U.:	SECTION	COUNTY	TOTAL SHEETS	SHEET NO.
1100	11-00087-00-FP	Cook	164	73
CONTRACT NO. 63770			ILLINOIS FED. AID PROJECT CMM 9003(757)	

STONINGTON AVENUE

NUMBER	LOCATION	MOUNT	EXISTING/PROPOSED	DESCRIPTION	PRIMARY SIGN			SECONDARY SIGN				
					MUTCD	W	H	EXISTING/PROPOSED	DESCRIPTION	MUTCD	W	H
26	28+21L	NEW POST	PROPOSED	BICYCLE	W11-1	30	30	PROPOSED	SHARE THE ROAD	W16-1P	18	24
27	29+00R	NEW POST	PROPOSED	VILLAGE HALL 0.7	D1-2C	30	6	PROPOSED	TRIPPAHN CENTER 1.4	D1-2C	30	6
28	29+58L	NEW POST	PROPOSED	BIKE LANE	R3-17	24	18	PROPOSED	ROSELLE RD TRL 3.2	D1-2C	30	6
29	30+33L	NEW POST	PROPOSED	TWO-WAY LEFT TURN ONLY	R3-9b	24	36	PROPOSED	ENDS	M4-6	12	6
30	30+70R	EX. POST	MAINTAIN EXISTING	SPEED LIMIT 30	R2-1	30	24	PROPOSED	TWO-WAY LEFT TURN ONLY	R3-9b	24	36
31	32+14R	NEW POST	PROPOSED	BIKE LANE	R3-17	24	18					
32	34+17L	NEW POST	PROPOSED	POPLAR CREEK TRL 0.8	D1-2C	30	6					
33	36+00R	NEW POST	PROPOSED	BIKE LANE	R3-17	24	18					
34	37+44L	EX. POST	MAINTAIN EXISTING	SPEED LIMIT 30	R2-1	30	24					

PLAN
 SURVEYED BY: _____
 NOTE BOOK ALIGNED CHECKED BY: _____
 NO. OF STATIONS: _____
 DATE: _____

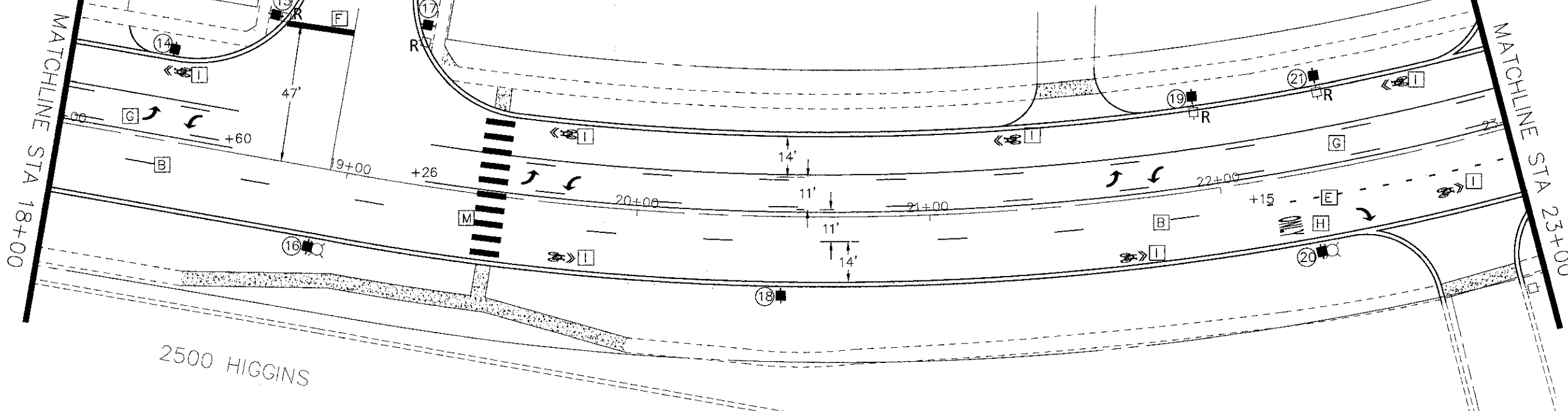

PROFILE
 SURVEYED BY: _____
 NOTE BOOK GRADES CHECKED BY: _____
 NO. OF STATIONS: _____
 DATE: _____

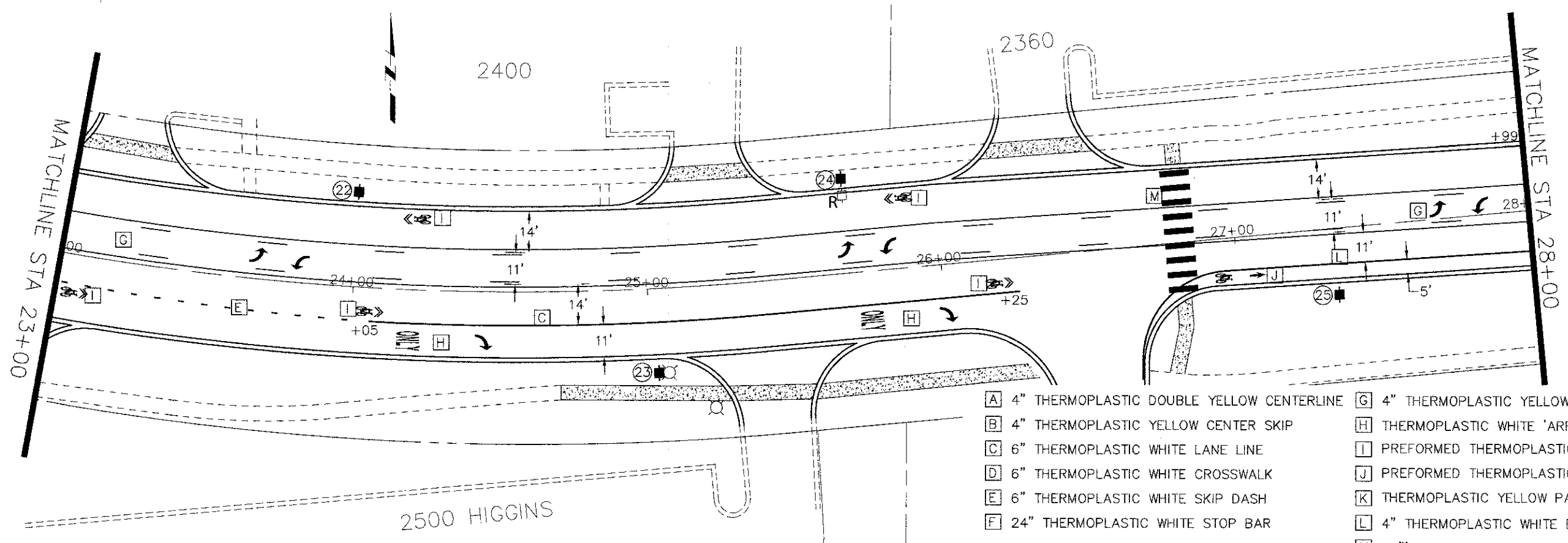

- A 4" THERMOPLASTIC DOUBLE YELLOW CENTERLINE
- B 4" THERMOPLASTIC YELLOW CENTER SKIP
- C 6" THERMOPLASTIC WHITE LANE LINE
- D 6" THERMOPLASTIC WHITE CROSSWALK
- E 6" THERMOPLASTIC WHITE SKIP DASH
- F 24" THERMOPLASTIC WHITE STOP BAR
- G 4" THERMOPLASTIC YELLOW TWO-WAY TURN MARKINGS
- H THERMOPLASTIC WHITE 'ARROW' AND 'ONLY'
- I PREFORMED THERMOPLASTIC WHITE SHARROW SYMBOL
- J PREFORMED THERMOPLASTIC WHITE BIKE LANE SYMBOL
- K THERMOPLASTIC YELLOW PAINTED MEDIAN
- L 4" THERMOPLASTIC WHITE EDGE LINE
- M 24" THERMOPLASTIC WHITE CROSSWALK - 2' STRIPE, 3' GAP

NUMBER	LOCATION	MOUNT	EXISTING/PROPOSED	DESCRIPTION	PRIMARY SIGN			SECONDARY SIGN				
					MUTCD	W	H	EXISTING/PROPOSED	DESCRIPTION	MUTCD	W	H
26	28+21L	NEW POST	PROPOSED	BICYCLE	W11-1	30	30	PROPOSED	SHARE THE ROAD	W16-1P	18	24
27	29+00R	NEW POST	PROPOSED	VILLAGE HALL 0.7	DI-2C	30	6	PROPOSED	TRIPHAN CENTER 1.4	DI-2C	30	6
28	29+58L	NEW POST	PROPOSED	BIKE LANE	R3-17	24	18	PROPOSED	ROSELLE RD TRL 3.2	DI-2C	30	6
29	30+33L	NEW POST	PROPOSED	TWO-WAY LEFT TURN ONLY	R3-9b	24	36		ENDS	M4-6	12	6
30	30+70R	EX. POST	MAINTAIN EXISTING	SPEED LIMIT 30	R2-1	30	24	PROPOSED	TWO-WAY LEFT TURN ONLY	R3-9b	24	36
31	32+14R	NEW POST	PROPOSED	BIKE LANE	R3-17	24	18					
32	34+17L	NEW POST	PROPOSED	POPLAR CREEK TRL 0.8	DI-2C	30	6					
33	36+00R	NEW POST	PROPOSED	BIKE LANE	R3-17	24	18					
34	37+44L	EX. POST	MAINTAIN EXISTING	SPEED LIMIT 30	R2-1	30	24					

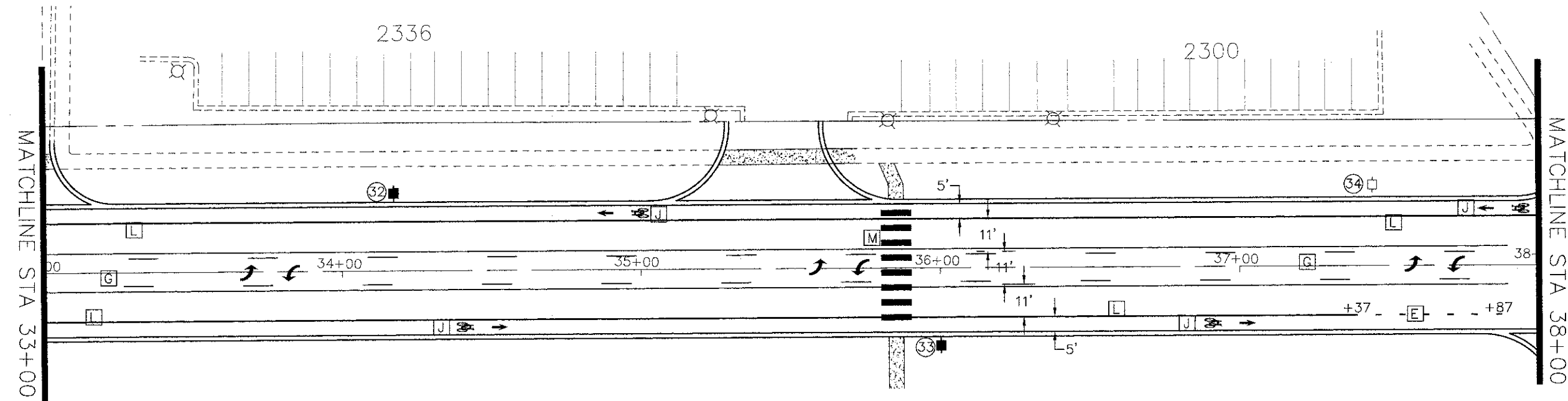
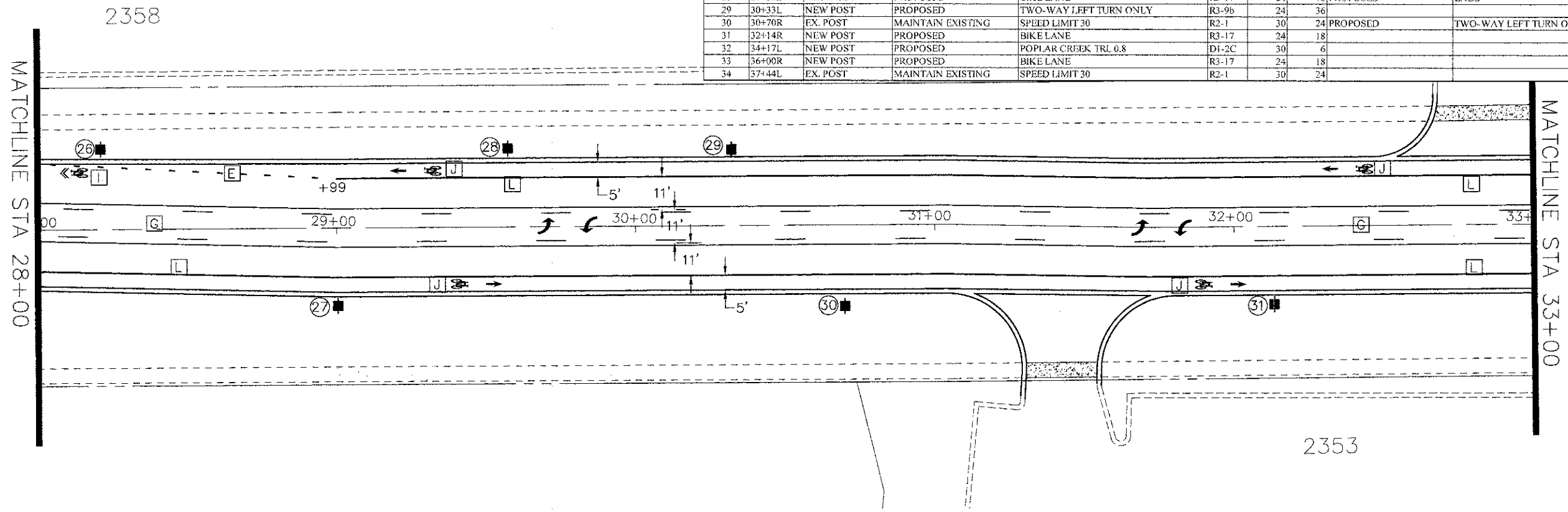

- [A] 4" THERMOPLASTIC DOUBLE YELLOW CENTERLINE
- [B] 4" THERMOPLASTIC YELLOW CENTER SKIP
- [C] 6" THERMOPLASTIC WHITE LANE LINE
- [D] 6" THERMOPLASTIC WHITE CROSSWALK
- [E] 6" THERMOPLASTIC WHITE SKIP DASH
- [F] 24" THERMOPLASTIC WHITE STOP BAR
- [G] 4" THERMOPLASTIC YELLOW TWO-WAY TURN MARKINGS
- [H] THERMOPLASTIC WHITE 'ARROW' AND 'ONLY'
- [I] PREFORMED THERMOPLASTIC WHITE SHARROW SYMBOL
- [J] PREFORMED THERMOPLASTIC WHITE BIKE LANE SYMBOL
- [K] THERMOPLASTIC YELLOW PAINTED MEDIAN
- [L] 4" THERMOPLASTIC WHITE EDGE LINE
- [M] 24" THERMOPLASTIC WHITE CROSSWALK - 2' STRIPE, 3' GAP

PLAN
 SURVEYED
 PLOTTED
 NOTE BOOK ALIGNED CHECKED
 NO. OF STRIPES NOTIFIED CHD

PROFILE
 SURVEYED
 PLOTTED
 NOTE BOOK GRADES CHECKED
 NO. OF STRIPES NOTIFIED CHD

FILE NAME =
 Hassell Plan-Profile.dwg

DESIGNED -	REVISED -
DRAWN -	REVISED -
CHECKED -	REVISED -
DATE -	REVISED -

STATE OF ILLINOIS
 DEPARTMENT OF TRANSPORTATION

Hassell Road STP Project
 Striping and Signage Plan
 SCALE: 1" = 20'
 SHEET NO. 3 OF 9 SHEETS
 STA. 28+00 TO STA 38+00

F.A.U. RTE. 1100	SECTION 11-00087-00-FP	COUNTY Cook	TOTAL SHEETS 164	SHEET NO. 75
CONTRACT NO. 63770				ILLINOIS FED. AID PROJECT CMM 9003(757)

2210

21

NUMBER	LOCATION	MOUNT	EXISTING/PROPOSED	DESCRIPTION	PRIMARY SIGN			SECONDARY SIGN					
					MUTCD	W	H	EXISTING/PROPOSED	DESCRIPTION	MUTCD	W	H	
35	38+15L	EX. POST	RELOCATE	STOP	R1-1	30	30						
36	38-35R	EX. LIGHT POLE	MAINTAIN EXISTING	STOP	R1-1	30	30						
37	39+00R	NEW POST	PROPOSED	BIKE LANE	R3-17	24	18						
38	39+54L	NEW POST	PROPOSED	BEGINS	R3-96P	30	12	PROPOSED	TWO-WAY LEFT TURN ONLY	R3-96	24	36	
39	40+25R	NEW POST	PROPOSED	ENDS	R3-96P	30	12	PROPOSED	TWO-WAY LEFT TURN ONLY	R3-96	24	36	
40	40+20L	NEW POST	PROPOSED	BIKE LANE	R3-17	24	18						
41	40+76R	EX. POST	MAINTAIN EXISTING	HASSELL ROAD		42	9		HOLBROOK LANE		42	9	
42	41+24R	EX. POST	MAINTAIN EXISTING	STOP	R1-1	30	30						
43	42+00R	NEW POST	PROPOSED	BIKE LANE	R3-17	24	18						
44	42+90R	EX. POST	MAINTAIN EXISTING	SPEED LIMIT 30	R2-1	30	24						
45	43+87R	EX. POST	MAINTAIN EXISTING	HASSELL ROAD		42	9		CARDIGAN PLACE		42	9	
46	44+26R	EX. POST	MAINTAIN EXISTING	STOP	R1-1	30	30						
47	44+74R	NEW POST	PROPOSED	BIKE LANE	R3-17	24	18						
48	45+95R	EX. POST	MAINTAIN EXISTING	HASSELL ROAD		48	9		BRIGHTON PLACE		42	9	
49	46+46R	EX. POST	MAINTAIN EXISTING	STOP	R1-1	30	30		KETTERING ROAD		54	9	
50	46+98R	NEW POST	PROPOSED	BIKE LANE	R3-17	24	18						
51	47+51L	EX. POST	RELOCATE	SPEED LIMIT 30	R2-1	30	24						

PLAN SURVEYED
 NOTE BOOK ALTIMETER CHECKED
 NO. _____ DATE _____
 SURVEYOR NAME _____
 CHECKED NAME _____

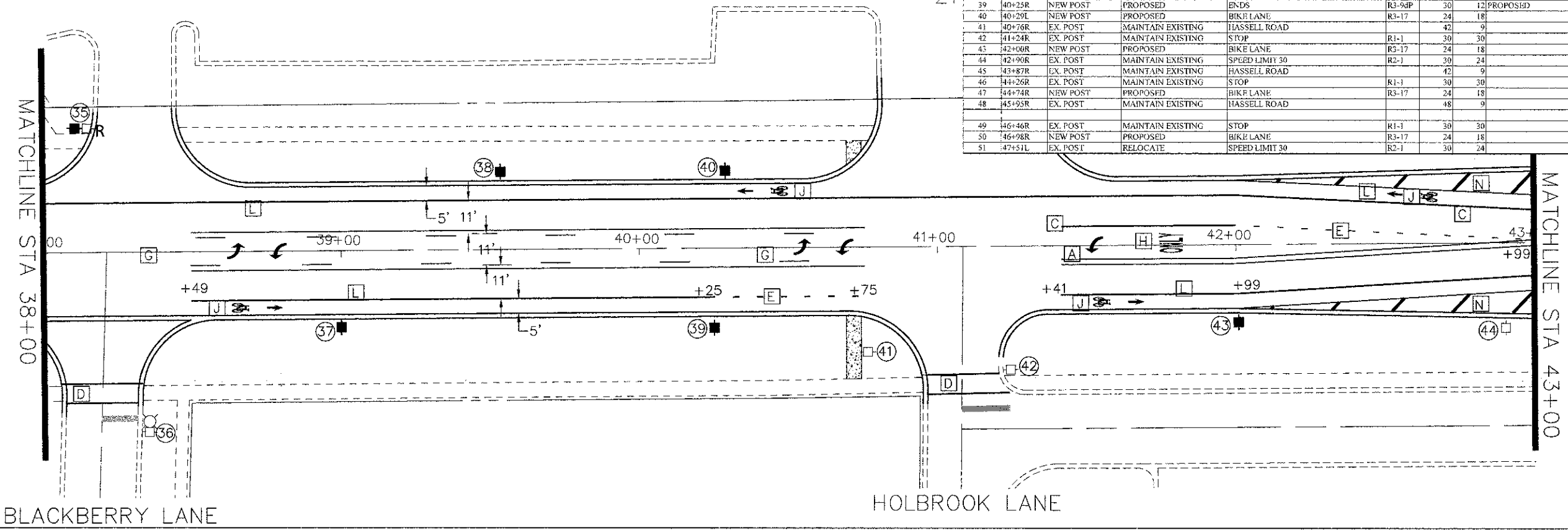

- [A] 4" THERMOPLASTIC DOUBLE YELLOW CENTERLINE
- [B] 4" THERMOPLASTIC YELLOW CENTER SKIP
- [C] 6" THERMOPLASTIC WHITE LANE LINE
- [D] 6" THERMOPLASTIC WHITE CROSSWALK
- [E] 6" THERMOPLASTIC WHITE SKIP DASH
- [F] 24" THERMOPLASTIC WHITE STOP BAR
- [G] 4" THERMOPLASTIC YELLOW TWO-WAY TURN MARKINGS
- [H] THERMOPLASTIC WHITE 'ARROW' AND 'ONLY'
- [I] PREFORMED THERMOPLASTIC WHITE SHARROW SYMBOL
- [J] PREFORMED THERMOPLASTIC WHITE BIKE LANE SYMBOL
- [K] THERMOPLASTIC YELLOW PAINTED MEDIAN
- [L] 4" THERMOPLASTIC WHITE EDGE LINE
- [M] 24" THERMOPLASTIC WHITE CROSSWALK - 2' STRIPE, 3' GAP
- [N] 12" THERMOPLASTIC WHITE CHANNELIZATION

PROFILE SURVEYED
 NOTE BOOK GRADES CHECKED
 NO. _____ DATE _____
 SURVEYOR NAME _____
 CHECKED NAME _____

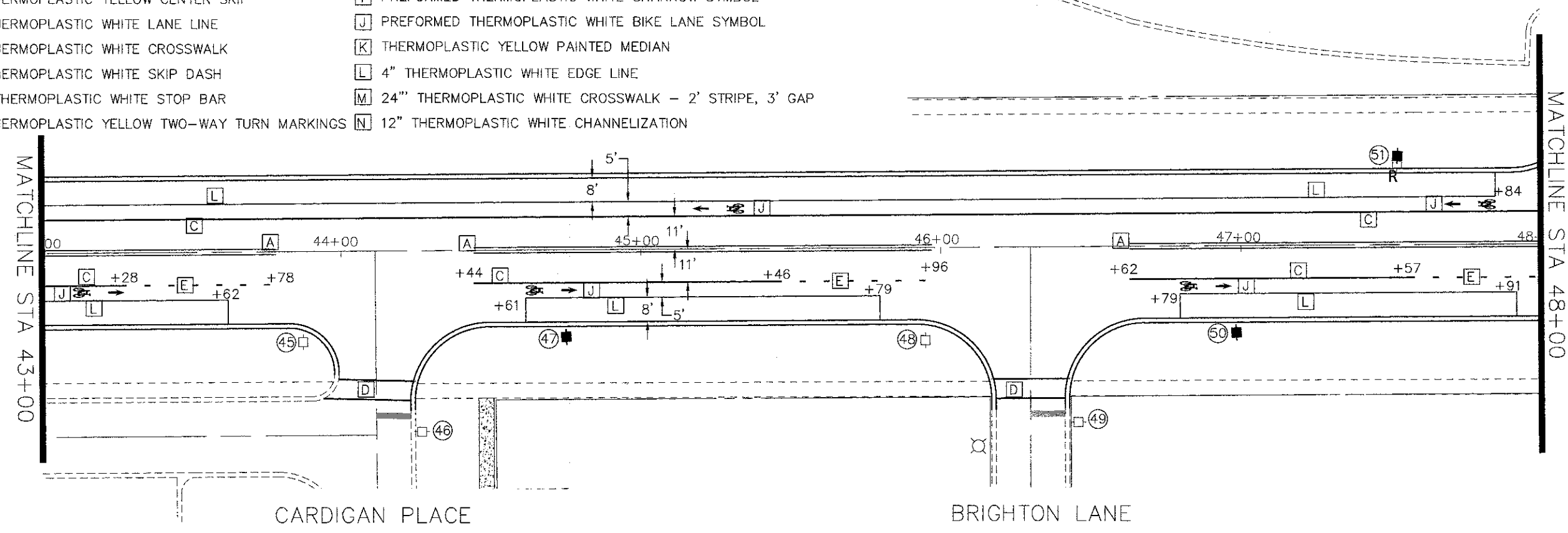

NUMBER	LOCATION	MOUNT	EXISTING/PROPOSED	PRIMARY SIGN			SECONDARY SIGN				
				DESCRIPTION	MUTCD	W	H	DESCRIPTION	MUTCD	W	H
52	48+08R	EX. POST	MAINTAIN EXISTING	HASSELL ROAD		42	9	KETTERING ROAD		36	9
53	48+56R	EX. POST	MAINTAIN EXISTING	STOP	R1-1	30	30	OXFORD LANE			
54	49+45R	EX. POST	RELOCATE	SPEED LIMIT 30	R2-1	30	24	BIKE LANE	R3-17	24	18
55	50+70L	EX. POST	RELOCATE	NO PARKING W/RIGHT ARROW	R8-3A	12	18				
56	50+74R	EX. LIGHT POLE	MAINTAIN EXISTING	STOP	R1-1	30	30				
57	50+89R	EX. POST	MAINTAIN EXISTING	HASSELL ROAD		42	9	GEORGETOWN LANE		54	9
58	51+53L	EX. POST	RELOCATE	NO PARKING W/LEFT ARROW	R8-3A	12	18				
59	52+35L	EX. POST	RELOCATE	NO PARKING W/RIGHT ARROW	R8-3A	12	18				
60	52+37R	EX. POST	MAINTAIN EXISTING	HASSELL ROAD		42	9	ERIE LANE		30	9
61	52+86R	EX. LIGHT POLE	MAINTAIN EXISTING	STOP	R1-1	30	30				
62	52+91L	EX. POST	MAINTAIN EXISTING	STOP	R1-1	30	30				
63	53+35R	EX. POST	RELOCATE	STOP AHEAD	W3-1A	30	30				
64	53+79L	EX. POST	RELOCATE	NO PARKING W/LEFT ARROW	R8-3A	12	18				
65	54+63R	EX. POST	RELOCATE	PEDESTRIAN CROSSING AHEAD		30	30	BIKE LANE	R3-17	24	18
66	56+28R	NEW POST	PROPOSED	VILLAGE HALL 0.2	D1-2C	30	6	TRIPHAHN CENTER 0.5	D1-2C	30	6
								ROSELLE RD TRI. 2.7	D1-2C	30	6
67	57+09L	EX. POST	RELOCATE	SPEED LIMIT 30	R2-1	30	24	BIKE LANE	R3-17	24	18
68	57+90R	EX. POST	RELOCATE	STOP	R1-1	30	30				

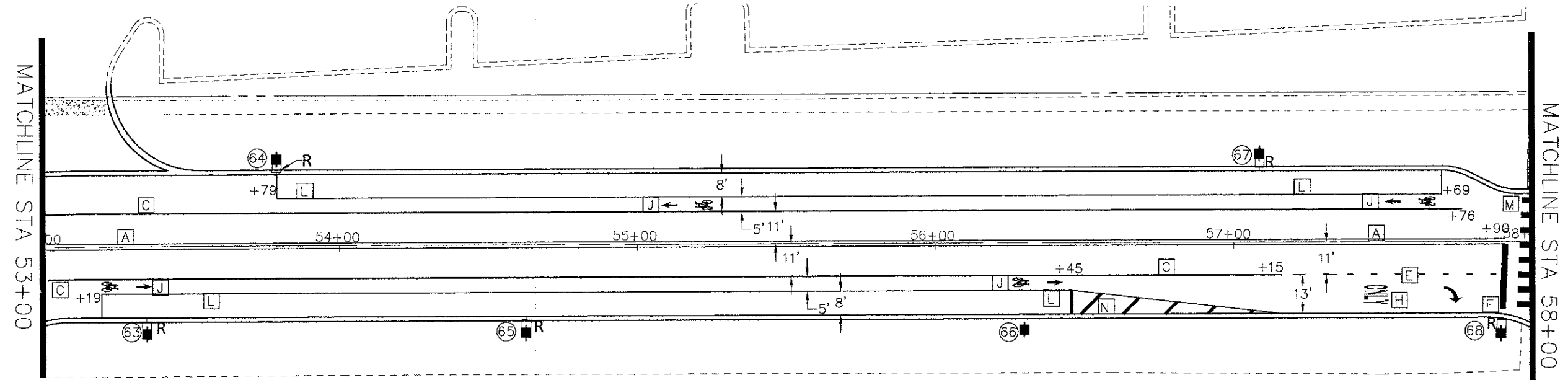
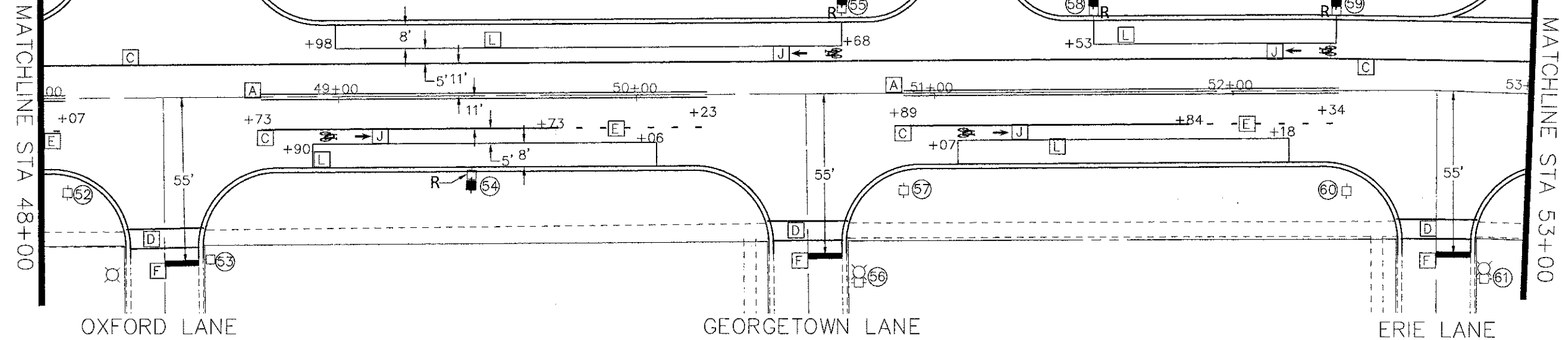

- | | |
|---|---|
| [A] 4" THERMOPLASTIC DOUBLE YELLOW CENTERLINE | [H] THERMOPLASTIC WHITE 'ARROW' AND 'ONLY' |
| [B] 4" THERMOPLASTIC YELLOW CENTER SKIP | [I] PREFORMED THERMOPLASTIC WHITE SHARROW SYMBOL |
| [C] 6" THERMOPLASTIC WHITE LANE LINE | [J] PREFORMED THERMOPLASTIC WHITE BIKE LANE SYMBOL |
| [D] 6" THERMOPLASTIC WHITE CROSSWALK | [K] THERMOPLASTIC YELLOW PAINTED MEDIAN |
| [E] 6" THERMOPLASTIC WHITE SKIP DASH | [L] 4" THERMOPLASTIC WHITE EDGE LINE |
| [F] 24" THERMOPLASTIC WHITE STOP BAR | [M] 24" THERMOPLASTIC WHITE CROSSWALK - 2' STRIPE, 3' GAP |
| [G] 4" THERMOPLASTIC YELLOW TWO-WAY TURN MARKINGS | [N] 12" THERMOPLASTIC WHITE CHANNELIZATION |

PLAN
 DRAWN BY: []
 CHECKED BY: []
 DATE: []
 NOTE BOOK NO. []

PROFILE
 DRAWN BY: []
 CHECKED BY: []
 DATE: []
 NOTE BOOK NO. []

NUMBER	LOCATION	MOUNT	PRIMARY SIGN			SECONDARY SIGN						
			EXISTING/PROPOSED	DESCRIPTION	MUTCD	W	H	EXISTING/PROPOSED	DESCRIPTION	MUTCD	W	H
69	58+58R	EX. LIGHT POLE	RELOCATE	STOP	R1-1	30	30					
70	58+81L	EX. POST	RELOCATE	STOP	R1-1	30	30					
71	59+43R	NEW POST	PROPOSED	BIKE LANE	R3-17	24	18					
72	59+66L	NEW POST	PROPOSED	SEASCAPE AQUATIC CNTR 1.2	D1-2C	30	6	PROPOSED	POPLAR CREEK TRL 1.3	D1-2C	30	6
73	61+82R	EX. POST	RELOCATE	SPEED LIMIT 30	R2-1	30	24					
74	62+95L	EX. POST	RELOCATE	SCHOOL CROSSWALK SYMBOL		36	36		AHEAD	W16-9P		
75	63+75L	EX. POST	RELOCATE	STOP AHEAD	W3-1A	30	30					
76	65+20R	EX. POST	RELOCATE	STOP AHEAD	W3-1A	30	30	PROPOSED	BIKE LANE	R3-17	24	18
77	66+05L	EX. POST	RELOCATE	SPEED LIMIT 30	R2-1	30	24					
78	66+74L	EX. POST	RELOCATE	NO PARKING W/RIGHT ARROW	R8-3A	12	18					
79	66+74R	EX. POST	RELOCATE	NO PARKING W/RIGHT ARROW	R8-3A	12	18					
80	66+95R	EX. POST	RELOCATE	PEDESTRIAN CROSSING SYMBOL	W11-2	30	30		RIGHT ARROW DOWN	W16-7PR		
81	67+14R	EX. POST	RELOCATE	GOLF CART CROSSING								
82	67+15L	EX. POST	RELOCATE	PEDESTRIAN CROSSING SYMBOL	W11-2	30	30		LEFT ARROW DOWN	W16-7PL		
83	67+36L	EX. POST	RELOCATE	NO PARKING W/LEFT ARROW	R8-3A	12	18					
84	67+36R	EX. POST	RELOCATE	NO PARKING W/RIGHT ARROW	R8-3A	12	18					

PLAN SURVEYED
 PLOTTED
 NOTE BOOK ALIGNMENT CHECKED
 NO. _____
 DATE _____
 BY _____

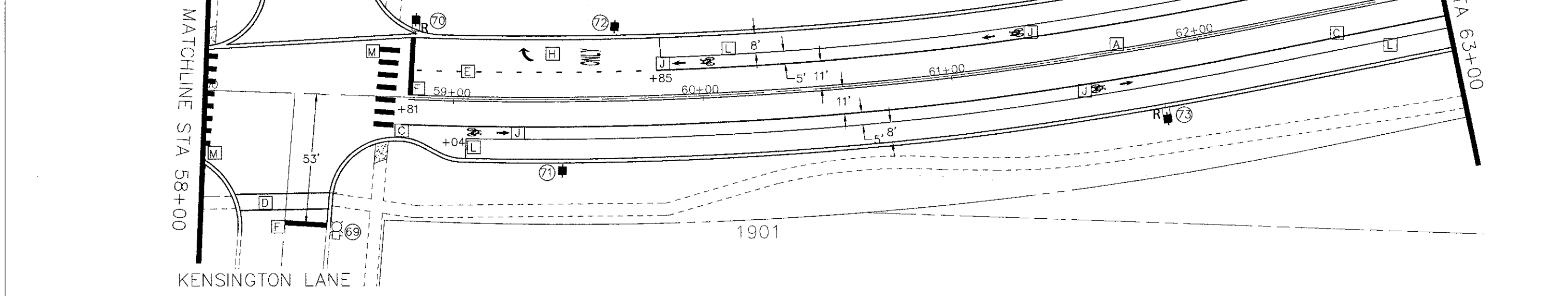

PROFILE SURVEYED
 PLOTTED
 NOTE BOOK GRADES CHECKED
 NO. _____
 DATE _____
 BY _____

- [A] 4" THERMOPLASTIC DOUBLE YELLOW CENTERLINE
- [B] 4" THERMOPLASTIC YELLOW CENTER SKIP
- [C] 6" THERMOPLASTIC WHITE LANE LINE
- [D] 6" THERMOPLASTIC WHITE CROSSWALK
- [E] 6" THERMOPLASTIC WHITE SKIP DASH
- [F] 24" THERMOPLASTIC WHITE STOP BAR
- [G] 4" THERMOPLASTIC YELLOW TWO-WAY TURN MARKINGS
- [H] THERMOPLASTIC WHITE 'ARROW' AND 'ONLY'
- [I] PREFORMED THERMOPLASTIC WHITE SHARROW SYMBOL
- [J] PREFORMED THERMOPLASTIC WHITE BIKE LANE SYMBOL
- [K] THERMOPLASTIC YELLOW PAINTED MEDIAN
- [L] 4" THERMOPLASTIC WHITE EDGE LINE
- [M] 24" THERMOPLASTIC WHITE CROSSWALK - 2' STRIPE, 3' GAP
- [N] 12" THERMOPLASTIC WHITE CHANNELIZATION

INSTALL WHITE PRISMATIC CURB REFLECTORS ON BUMP OUT AT 10' C-C

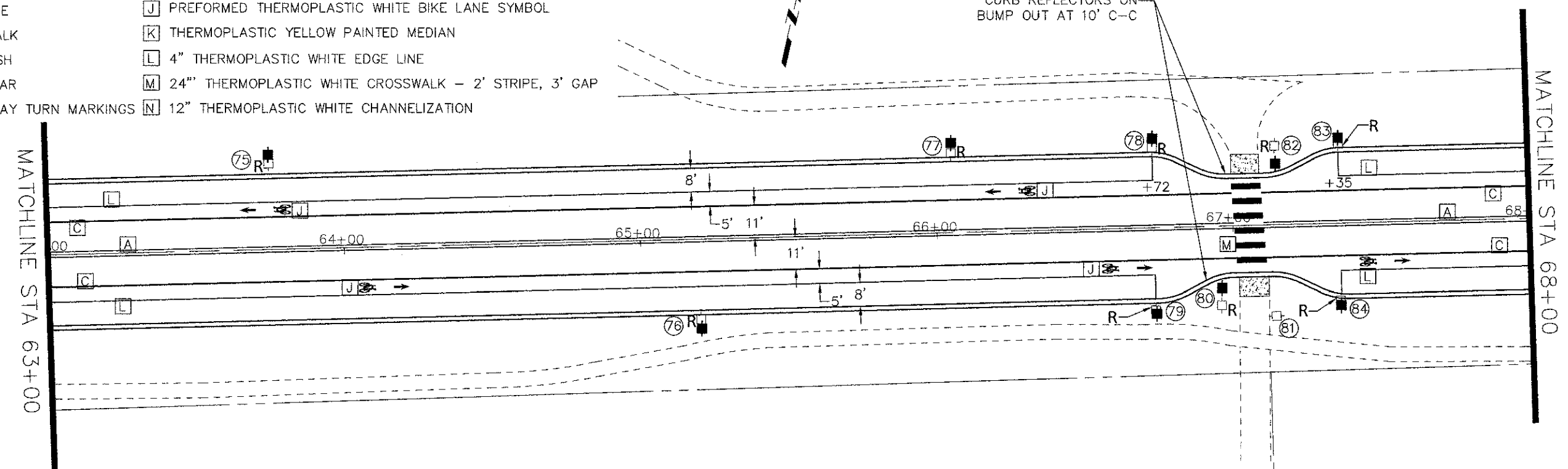

PLAN
 SURVEYED BY: []
 NOTE BOOK ALIGNED CHECKED: []
 NO. OF WYS CHECKED: []
 SAMPLE NAME: []

PROFILE
 SURVEYED BY: []
 DATE: []
 NOTE BOOK GRADES CHECKED: []
 NO. OF NOTES: []
 STRUCTURE NOTATIONS: []

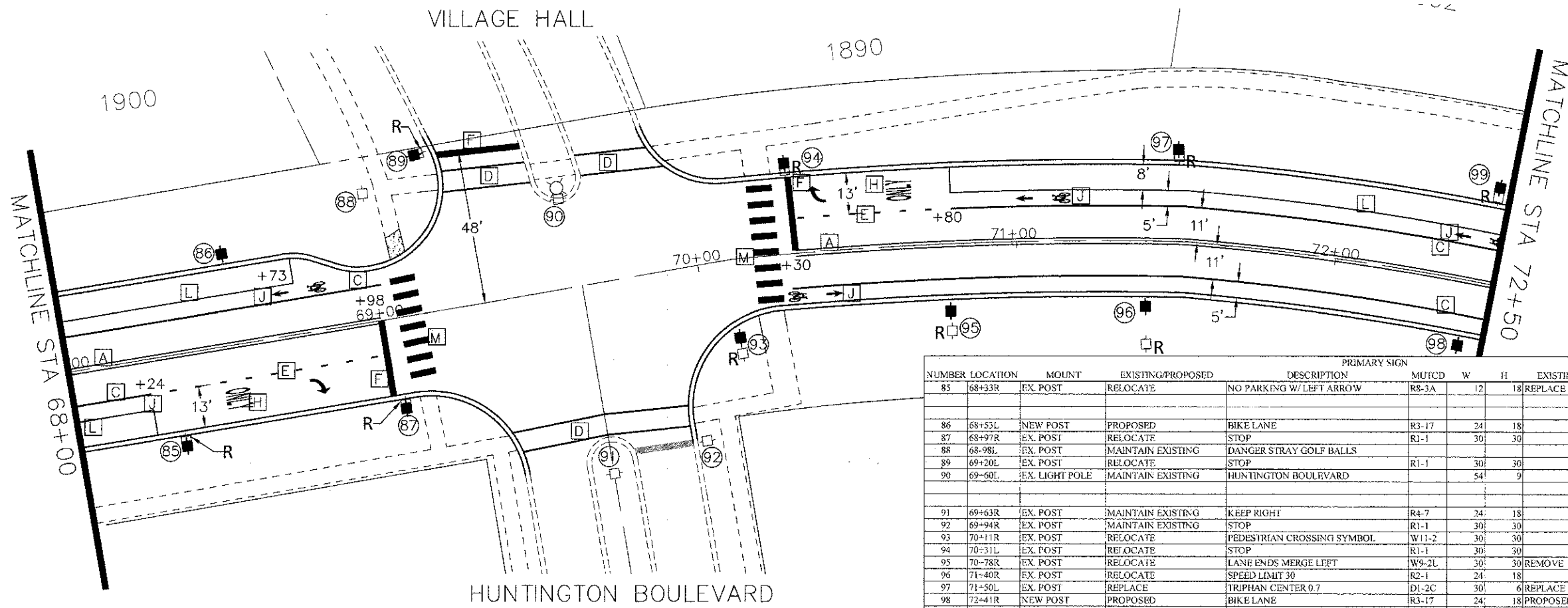

NUMBER	LOCATION	MOUNT	EXISTING/PROPOSED	DESCRIPTION	PRIMARY SIGN			EXISTING/PROPOSED	SECONDARY SIGN			
					MUTCD	W	H		DESCRIPTION	MUTCD	W	H
85	68+33R	EX. POST	RELOCATE	NO PARKING W/ LEFT ARROW	R8-3A	12	18	REPLACE	ROSELLE RD TRL 2.5	D1-2C	30	6
									VILLAGE HALL	D1-2C	30	6
									TRIPHANN CENTER 0.7	D1-2C	30	6
86	68+53L	NEW POST	PROPOSED	BIKE LANE	R3-17	24	18					
87	68+97R	EX. POST	RELOCATE	STOP	R1-1	30	30					
88	68-98L	EX. POST	MAINTAIN EXISTING	DANGER STRAY GOLF BALLS								
89	69+20L	EX. POST	RELOCATE	STOP	R1-1	30	30		4-WAY	R1-3-4	12	6
90	69-60L	EX. LIGHT POLE	MAINTAIN EXISTING	HUNTINGTON BOULEVARD			54	9	VILLAGE HALL		48	9
									PUBLIC LIBRARY		54	9
									HASSELL ROAD		48	9
91	69+63R	EX. POST	MAINTAIN EXISTING	KEEP RIGHT	R4-7	24	18					
92	69+94R	EX. POST	MAINTAIN EXISTING	STOP	R1-1	30	30		4-WAY	R1-3-4	12	6
93	70+11R	EX. POST	RELOCATE	PEDESTRIAN CROSSING SYMBOL	W11-2	30	30					
94	70-31L	EX. POST	RELOCATE	STOP	R1-1	30	30					
95	70-78R	EX. POST	RELOCATE	LANE ENDS MERGE LEFT	W9-2L	30	30	REMOVE	BIKE ROUTE	D11-1	24	18
96	71+40R	EX. POST	RELOCATE	SPEED LIMIT 30	R2-1	24	18		NO PARKING ANYTIME	R7-31B	12	18
97	71+50L	EX. POST	REPLACE	TRIPHANN CENTER 0.7	D1-2C	30	30	REPLACE	VILLAGE HALL	D1-2C	30	6
98	72+41R	NEW POST	PROPOSED	BIKE LANE	R3-17	24	18	PROPOSED	ENDS	M4-6	12	6
99	72-47L	EX. POST	RELOCATE	STOP AHEAD	W3-1A	30	30	PROPOSED	BIKE LANE	R3-17	24	18
								PROPOSED	BEGINS	M4-14	12	6
100	72+87L	EX. POST	MAINTAIN EXISTING	STOP	R1-1	30	30					
101	73+26L	EX. POST	MAINTAIN EXISTING	HASSELL ROAD			42	9	PARKVIEW CIRCLE (W)		54	9
102	73+98R	NEW POST	PROPOSED	BICYCLE	W11-1	30	30	PROPOSED	SHARE THE ROAD	W16-1P	18	24
103	74+49L	EX. POST	MAINTAIN EXISTING	SPEED LIMIT 30	R2-1	24	18					
104	74+55R	EX. POST	MAINTAIN EXISTING	NO PARKING ANYTIME	R7-31B	12	18					
105	75+98L	EX. POST	MAINTAIN EXISTING	STOP	R1-1	30	30					
106	76+43L	EX. POST	MAINTAIN EXISTING	HASSELL ROAD			42	9	PARKVIEW CIRCLE (E)		48	9

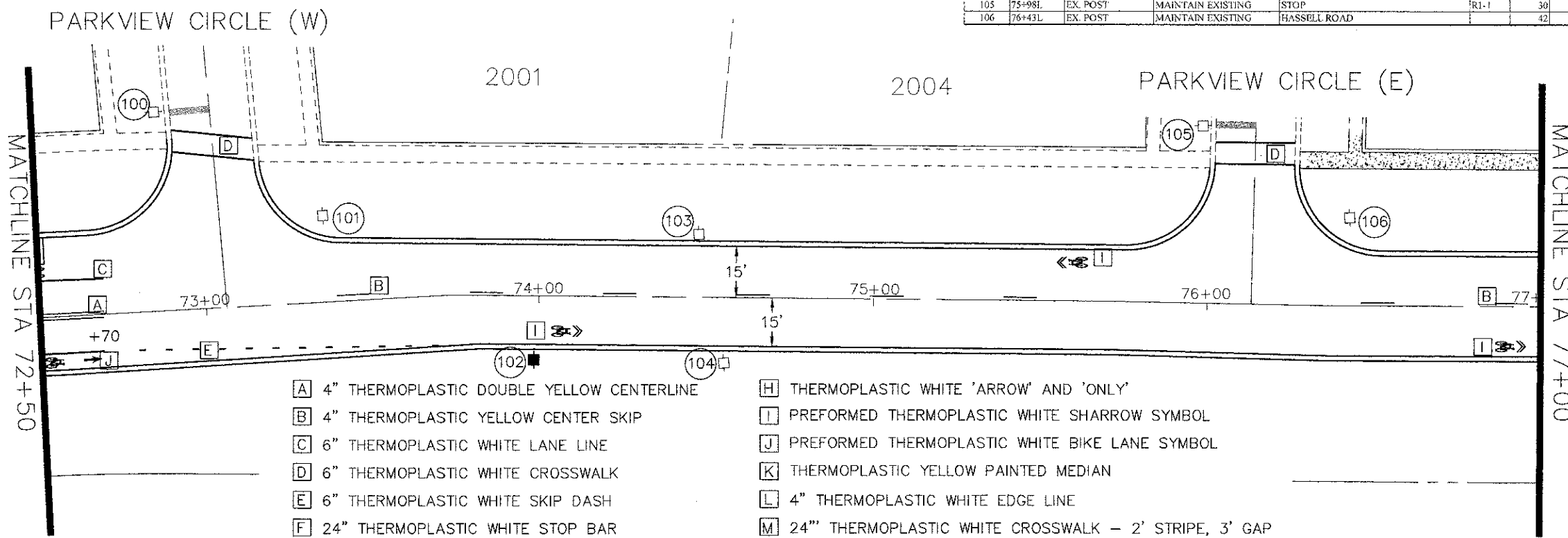

- [A] 4" THERMOPLASTIC DOUBLE YELLOW CENTERLINE
- [B] 4" THERMOPLASTIC YELLOW CENTER SKIP
- [C] 6" THERMOPLASTIC WHITE LANE LINE
- [D] 6" THERMOPLASTIC WHITE CROSSWALK
- [E] 6" THERMOPLASTIC WHITE SKIP DASH
- [F] 24" THERMOPLASTIC WHITE STOP BAR
- [G] 4" THERMOPLASTIC YELLOW TWO-WAY TURN MARKINGS
- [H] THERMOPLASTIC WHITE 'ARROW' AND 'ONLY'
- [I] PREFORMED THERMOPLASTIC WHITE SHARROW SYMBOL
- [J] PREFORMED THERMOPLASTIC WHITE BIKE LANE SYMBOL
- [K] THERMOPLASTIC YELLOW PAINTED MEDIAN
- [L] 4" THERMOPLASTIC WHITE EDGE LINE
- [M] 24" THERMOPLASTIC WHITE CROSSWALK - 2' STRIPE, 3' GAP
- [N] 12" THERMOPLASTIC WHITE CHANNELIZATION

NUMBER	LOCATION	MOUNT	PRIMARY SIGN				SECONDARY SIGN					
			EXISTING/PROPOSED	DESCRIPTION	MUTCD	W	H	EXISTING/PROPOSED	DESCRIPTION	MUTCD	W	H
107	77+68R	EX. POST	MAINTAIN EXISTING	SPEED LIMIT 30	R2-1	24	18					
108	78+43L	EX. POST	MAINTAIN EXISTING	SPEED LIMIT 25	R2-1	24	18					
109	79+65R	EX. POST	MAINTAIN EXISTING	NO PARKING THIS SIDE	R7-31A	12	18					
110	80+17L	EX. POST	MAINTAIN EXISTING	STOP	R1-1	30	30					
111	80+62L	EX. POST	MAINTAIN EXISTING	HASSELL ROAD		42	9					
112	81+15R	EX. POST	MAINTAIN EXISTING	SPEED LIMIT 25	R2-1	24	18					
113	81+75R	NEW POST	PROPOSED	BICYCLE	W11-1	30	30	PROPOSED	SHARE THE ROAD	W16-1P	18	24
114	81+55L	EX. POST	MAINTAIN EXISTING	NO PARKING	R8-3A	12	18					
115	82+79L	EX. POST	MAINTAIN EXISTING	NO PARKING	R8-3A	12	18					
116	83+45R	EX. POST	MAINTAIN EXISTING	NO PARKING	R7-31B	12	18	MAINTAIN EXISTING	BIKE ROUTE	D11-1	24	18
117	83+91L	EX. POST	MAINTAIN EXISTING	NO PARKING W/LEFT ARROW	R8-3A	12	18	MAINTAIN EXISTING	BIKE ROUTE	D11-1	24	18
118	86+85R	EX. POST	MAINTAIN EXISTING	NO PARKING W/RIGHT ARROW	R7-31B	12	18					
119	88+31R	EX. POST	MAINTAIN EXISTING	HASSELL ROAD		42	9					

ROSEDALE LANE

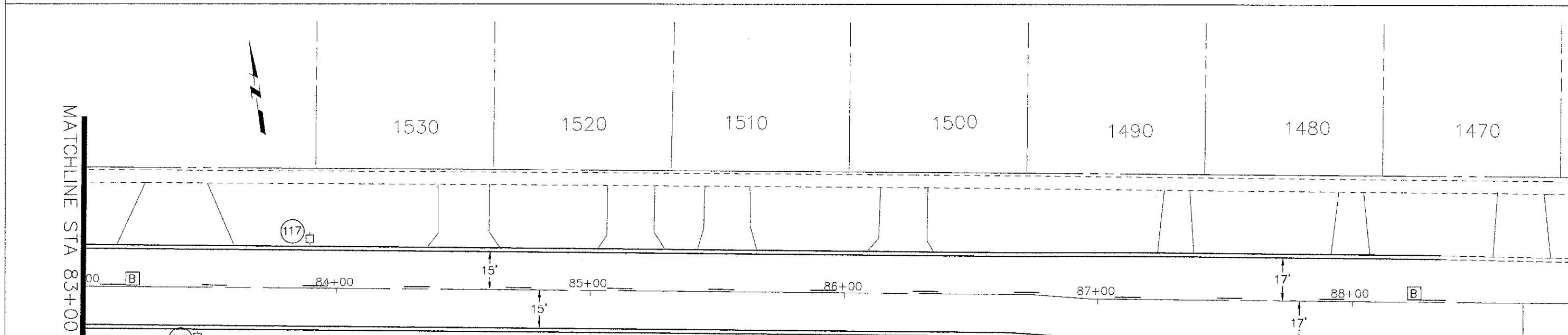
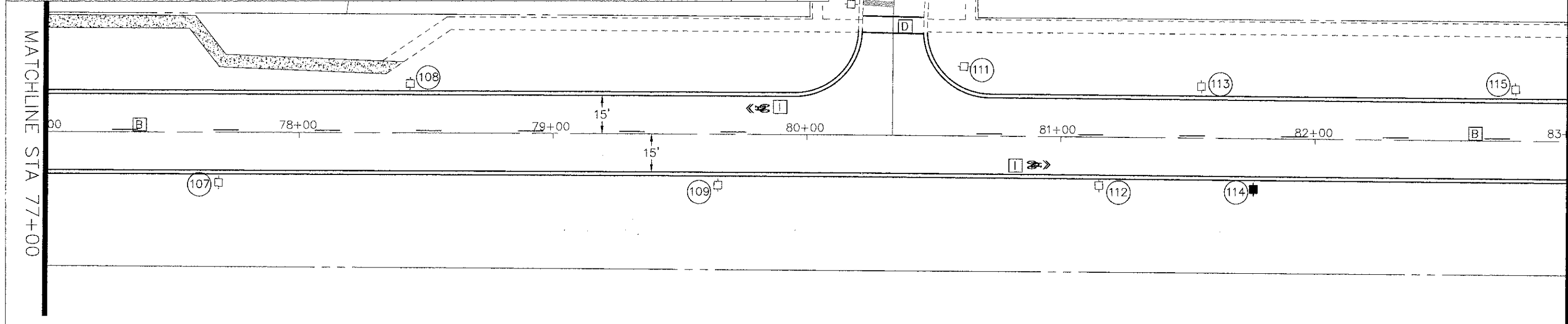

- [A] 4" THERMOPLASTIC DOUBLE YELLOW CENTERLINE
- [B] 4" THERMOPLASTIC YELLOW CENTER SKIP
- [C] 6" THERMOPLASTIC WHITE LANE LINE
- [D] 6" THERMOPLASTIC WHITE CROSSWALK
- [E] 6" THERMOPLASTIC WHITE SKIP DASH
- [F] 24" THERMOPLASTIC WHITE STOP BAR
- [G] 4" THERMOPLASTIC YELLOW TWO-WAY TURN MARKINGS
- [H] THERMOPLASTIC WHITE 'ARROW' AND 'ONLY'
- [I] PREFORMED THERMOPLASTIC WHITE SHARROW SYMBOL
- [J] PREFORMED THERMOPLASTIC WHITE BIKE LANE SYMBOL
- [K] THERMOPLASTIC YELLOW PAINTED MEDIAN
- [L] 4" THERMOPLASTIC WHITE EDGE LINE
- [M] 24" THERMOPLASTIC WHITE CROSSWALK - 2' STRIPE, 3' GAP
- [N] 12" THERMOPLASTIC WHITE CHANNELIZATION

FAIRWAY COURT

1996

PLAN SURVEYED BY: []
 PLOTTED BY: []
 CHECKED BY: []
 DATE: []
 NOTE BOOK NO.: []
 DATE OF WAY CHECKED: []
 CADFILE NAME: []

PROFILE SURVEYED BY: []
 PLOTTED BY: []
 CHECKED BY: []
 DATE: []
 NOTE BOOK NO.: []
 DATE OF WAY CHECKED: []
 STRUCTURE NOTATIONS CHKD: []

PLAN	REVISED	DATE
NOTE BOOK	ALIGNED	CHECKED
NO.	DATE	BY

PROFILE	REVISED	DATE
NOTE BOOK	GRADES	CHECKED
NO.	DATE	BY

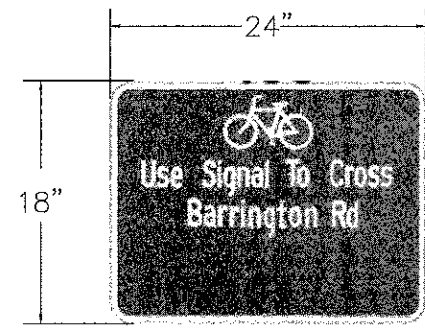

STA 13+12L

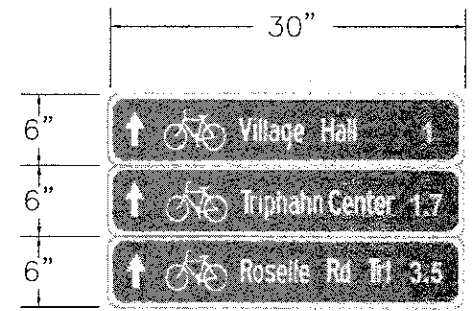

D1-2C
STA 14+91R

USE 30" X 18" SIGN BLANK

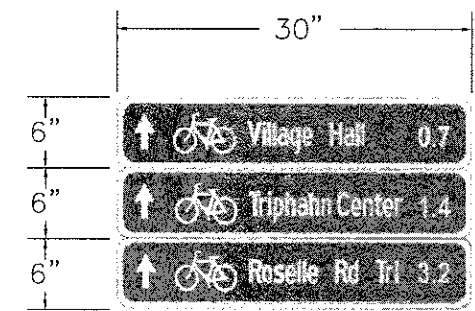

D1-2C
STA 29+00R

USE 30" X 18" SIGN BLANK

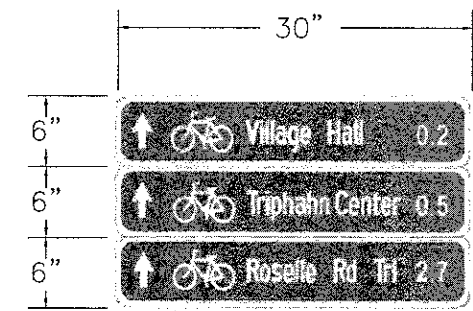

D1-2C
STA 56+28R

USE 30" X 18" SIGN BLANK

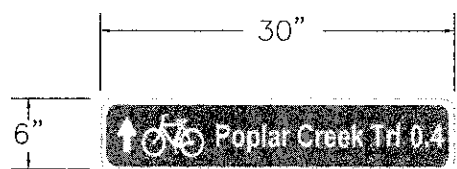

D1-2C
STA 16+90L

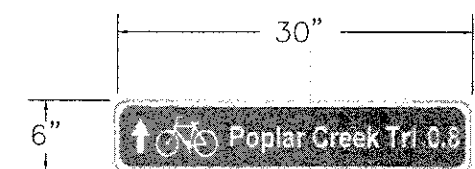

D1-2C
STA 34+17L

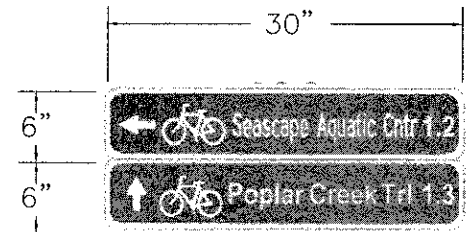

D1-2C
STA 59+66L

USE 30" X 12" SIGN BLANK

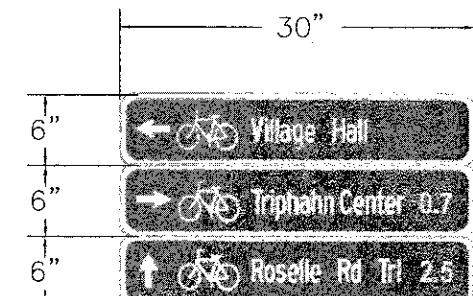

D1-2C
STA 68+33R

USE 30" X 18" SIGN BLANK

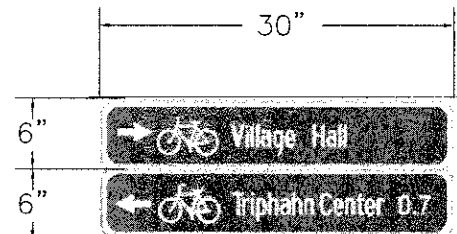

D1-2C
STA 71+50L

USE 30" X 12" SIGN BLANK

PLAN
 SURVEYED _____
 NOTE BOOK _____
 ALIGNMENT CHECKED _____
 BY _____
 DATE _____
 NO. _____

PROFILE
 SURVEYED _____
 NOTE BOOK _____
 GRADES CHECKED _____
 BY _____
 DATE _____
 NO. _____

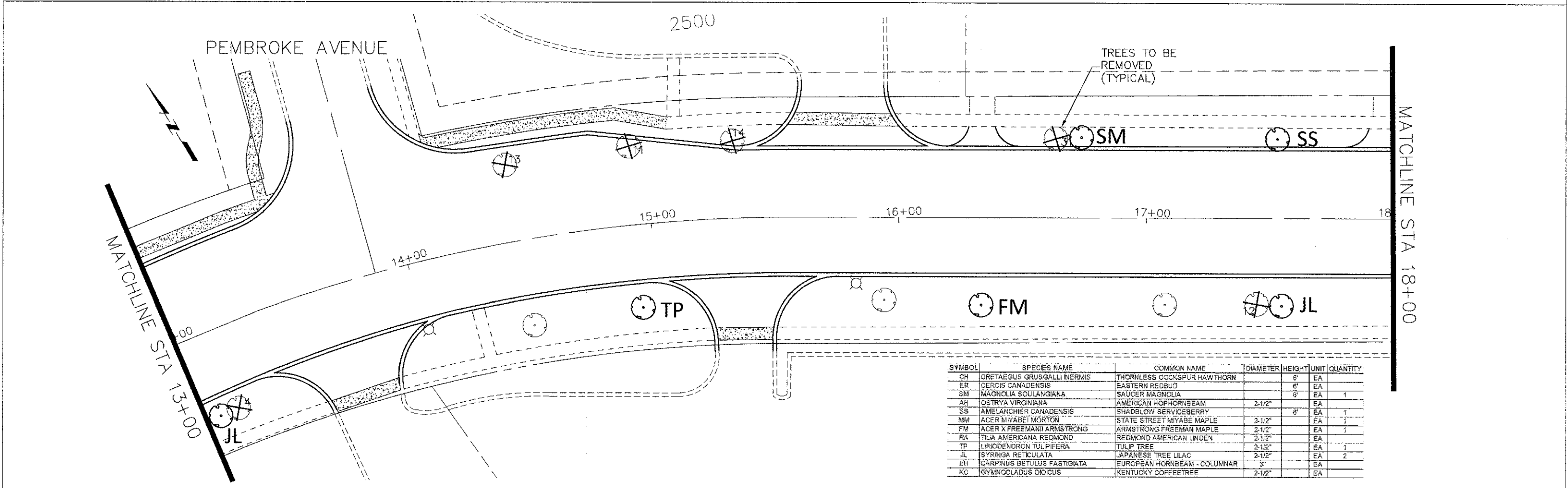
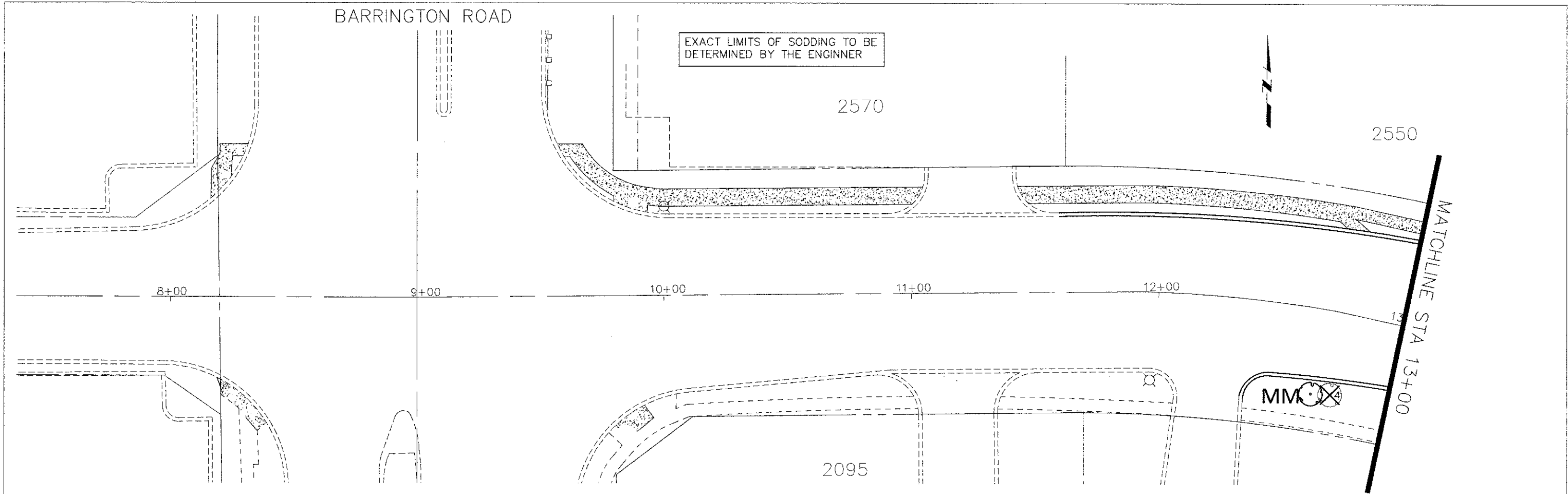

SYMBOL	SPECIES NAME	COMMON NAME	DIAMETER	HEIGHT	UNIT	QUANTITY
CH	ORETAEGUS GRUSGALLI INERMIS	THORNLESS COCKSPUR HAWTHORN		6'	EA	
ER	CERCIS CANADENSIS	EASTERN REDBUD		6'	EA	
SM	MAGNOLIA SOULANGIANA	SAUCER MAGNOLIA		6'	EA	1
AH	OSTRYA VIRGINIANA	AMERICAN HOPHORNBEAM	2-1/2"		EA	
SS	AMELANCHIER CANADENSIS	SHADBLOW SERVICEBERRY		8'	EA	1
MM	ACER MIYABEI MORTON	STATE STREET MIYABEI MAPLE	2-1/2"		EA	1
FM	ACER X FREEMANII ARMSTRONG	ARMSTRONG FREEMAN MAPLE	2-1/2"		EA	1
RA	TILIA AMERICANA REDMOND	REDMOND AMERICAN LINDEN	2-1/2"		EA	
TP	LIRIODENDRON TULPIFERA	TULIP TREE	2-1/2"		EA	1
JL	SYRINGA RETICULATA	JAPANESE TREE LILAC	2-1/2"		EA	2
EH	CARPINUS BETULUS FASTIGIATA	EUROPEAN HORNBEAM - COLUMNAR	3"		EA	
KC	GYMNOCALADUS DIOICUS	KENTUCKY COFFEE TREE	2-1/2"		EA	

STONINGTON AVENUE

EXACT LIMITS OF SODDING TO BE DETERMINED BY THE ENGINEER

SYMBOL	SPECIES NAME	COMMON NAME	DIAMETER	HEIGHT	UNIT	QUANTITY
CH	CORYLUS CORNUS GRUSCALLI INERMIS	THORNLESS COCKSPUR HAWTHORN	6"	8'	EA	3
ER	CERCIS CANADENSIS	EASTERN REDBUD	6"	8'	EA	3
SM	MAGNOLIA SOULANGIANA	SAUCER MAGNOLIA	6"	8'	EA	2
AH	Ostrya virginiana	AMERICAN HOPHORNBEAM	2-1/2"		EA	1
SS	AMELANCHIER CANADENSIS	SHADBLOW SERVICEBERRY	6"	8'	EA	2
MM	ACER MIYABEI MORTON	STATE STREET MIYABE MAPLE	2-1/2"		EA	2
FM	ACER X FREEMANII ARMSTRONG	ARMSTRONG FREEMAN MAPLE	2-1/2"		EA	1
RA	TILIA AMERICANA REDMOND	REDMOND AMERICAN LINDEN	2-1/2"		EA	2
TP	LIRIODENDRON TULIPIFERA	TULIP TREE	2-1/2"		EA	1
JL	SYRINGA RETICULATA	JAPANESE TREE LILAC	2-1/2"		EA	2
EH	CARPINUS BETULUS FASTIGIATA	EUROPEAN HORNBEAM - COLUMNAR	3"		EA	2
KC	GYMNOCLADUS DIOICUS	KENTUCKY COFFEETREE	2-1/2"		EA	3

PLAN	SURVEYED	DATE	BY
	ALLOTTED		
	NOTED		
	CHECKED		
	BY		
	NO. OF WAY CHECKED		
	NO.		
	CADFILE NAME		

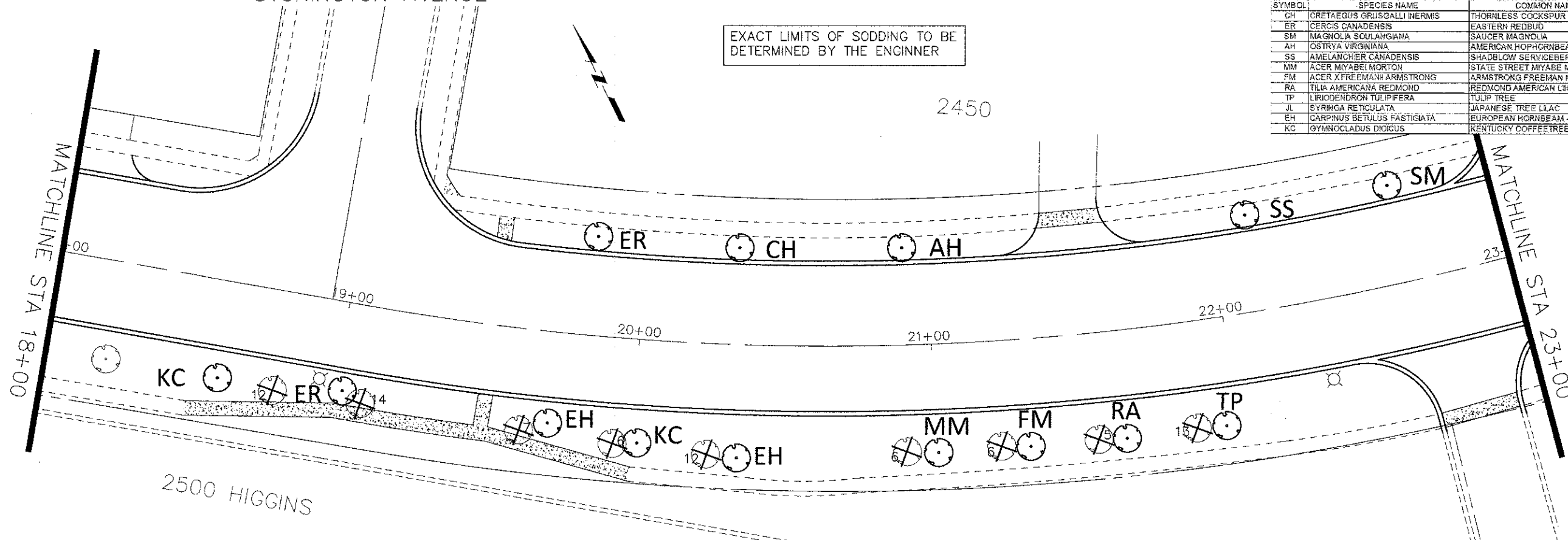

PROFILE	SURVEYED	DATE	BY
	ALLOTTED		
	NOTED		
	CHECKED		
	BY		
	NO. OF STRUCTURE NOTATIONS CHECKED		
	NO.		

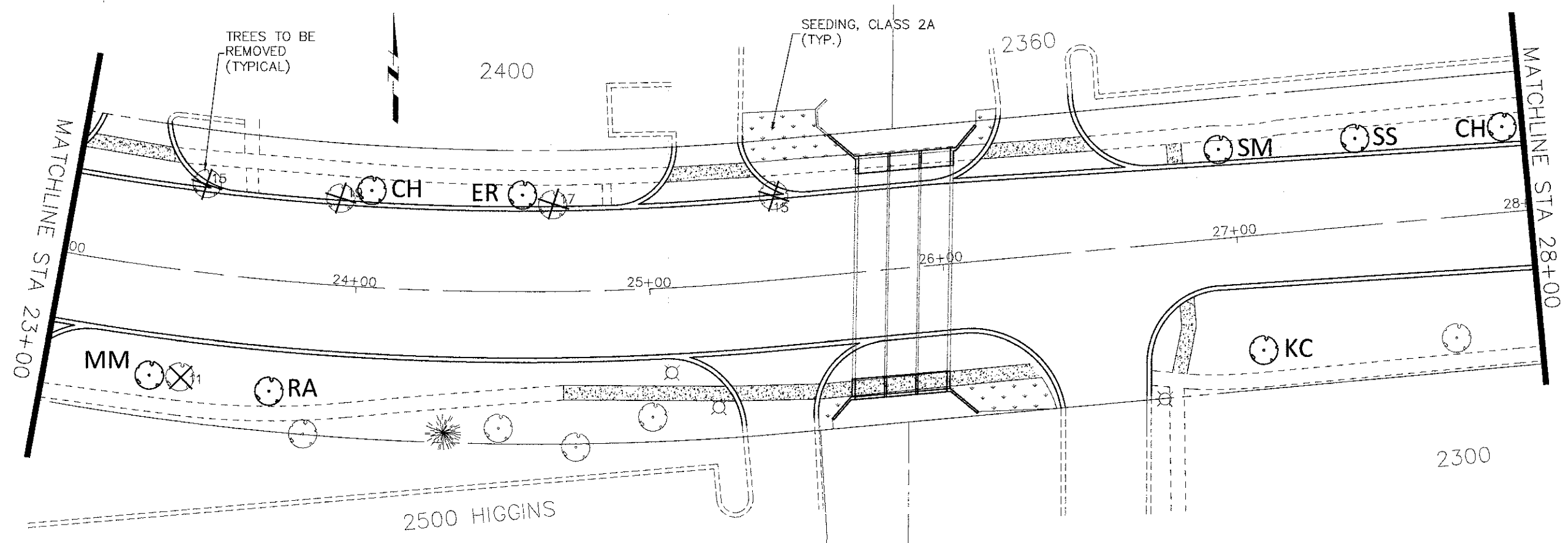

FILE NAME = Hassell Plan-Profile.dwg

DESIGNED -	REVISED -
DRAWN -	REVISED -
CHECKED -	REVISED -
DATE -	REVISED -

STATE OF ILLINOIS
DEPARTMENT OF TRANSPORTATION

Hassell Road STP Project
Landscaping Plan

SCALE: 1" = 20' SHEET NO. 2 OF 8 SHEETS STA. 18+00 TO STA 28+00

F.A.U. RTE.	SECTION	COUNTY	TOTAL SHEETS	SHEET NO.
11-00087-00-FP		Cook	164	83
CONTRACT NO. 63770			ILLINOIS FED. AID PROJECT CMM 9003(757)	

EXACT LIMITS OF SODDING TO BE DETERMINED BY THE ENGINEER

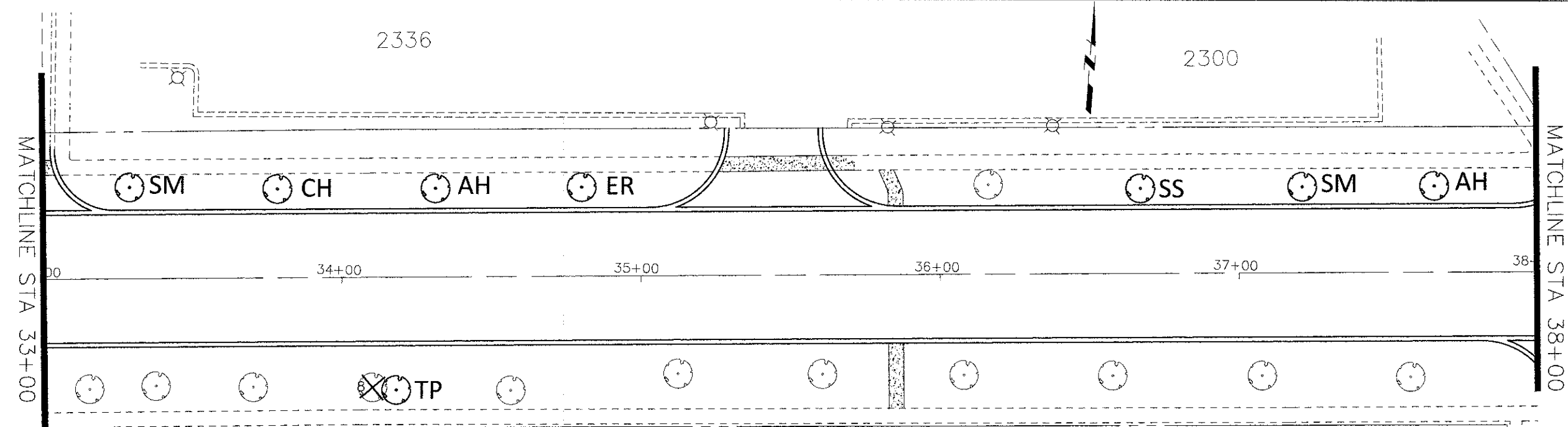
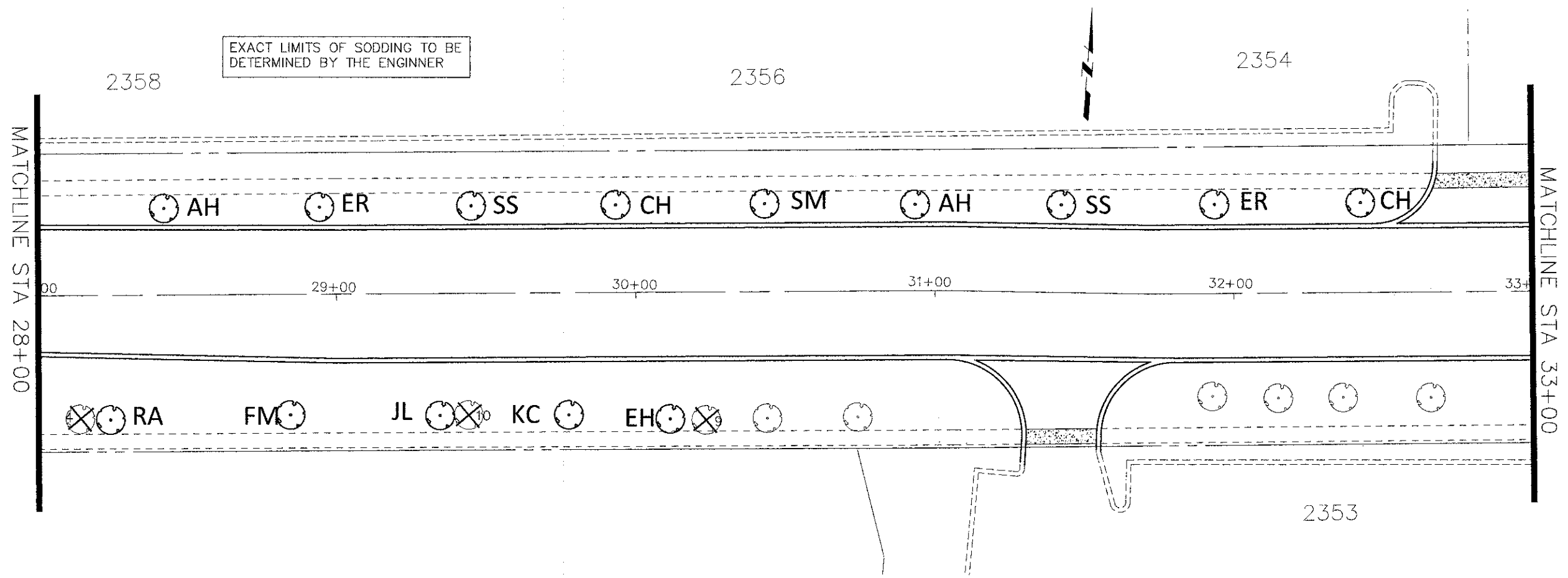

SYMBOL	SPECIES NAME	COMMON NAME	DIAMETER	HEIGHT	UNIT	QUANTITY
CH	CRETAEGUS GRUSGALLI INERMIS	THORNLESS COCKSPUR HAWTHORN		8'	EA	3
ER	CERCIS CANADENSIS	EASTERN REDBUD		8'	EA	3
SM	MAGNOLIA SOULANGIANA	SAUCER MAGNOLIA		8'	EA	3
AH	OSTRYA VIRGINIANA	AMERICAN HOPHORNBEAM	2-1/2"		EA	4
SS	AMELANCHIER CANADENSIS	SHADBLOW SERVICEBERRY		6'	EA	3
MM	ACER MIYABEI MORTON	STATE STREET MIYABE MAPLE	2-1/2"		EA	
FM	ACER X FREEMANI ARMSTRONG	ARMSTRONG FREEMAN MAPLE	2-1/2"		EA	1
RA	TILIA AMERICANA REDMOND	REDMOND AMERICAN LINDEN	2-1/2"		EA	1
TP	LIRIODENDRON TULIPIFERA	TULIP TREE	2-1/2"		EA	1
JL	SYRINGA RETICULATA	JAPANESE TREE LILAC	2-1/2"		EA	1
EH	CARPINUS BETULUS FASTIGIATA	EUROPEAN HORNBEAM - COLUMNAR	3"		EA	1
KC	GYMNOCLADUS DIOICUS	KENTUCKY COFFEETREE	2-1/2"		EA	1

PLAN SURVEYED
PLOTTED
NOTE BOOK ALIGNED CHECKED
NO. _____
DATE _____
BY _____

PROFILE SURVEYED
PLOTTED
NOTE BOOK GRADES CHECKED
NO. _____
DATE _____
BY _____

FILE NAME =
Hassell Plan-Profile.dwg

DESIGNED -	REVISD -
DRAWN -	REVISD -
CHECKED -	REVISD -
DATE -	REVISD -

**STATE OF ILLINOIS
DEPARTMENT OF TRANSPORTATION**

Hassell Road STP Project
Landscaping Plan

SCALE: 1" = 20' SHEET NO. 3 OF 8 SHEETS STA. 28+00 TO STA 38+00

F.A.U. RTE.	SECTION	COUNTY	TOTAL SHEETS	SHEET NO.
1100	11-00087-00-FP	Cook	164	84
CONTRACT NO. 63770			ILLINOIS FED. AID PROJECT CMM 9003(757)	

PLAN	DRAWN	DATE	BY
	PLOTTED		
	ALIGNED		
	CHECKED		
	NO. _____		

PROFILE	DRAWN	DATE	BY
	PLOTTED		
	CHECKED		
	NO. _____		

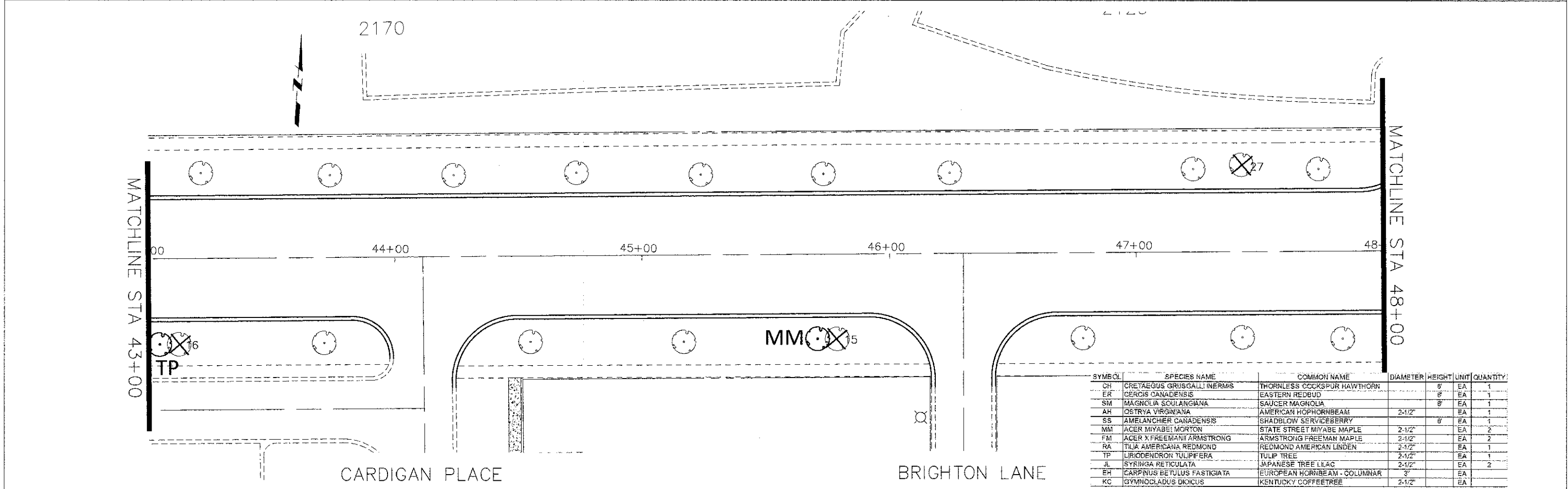
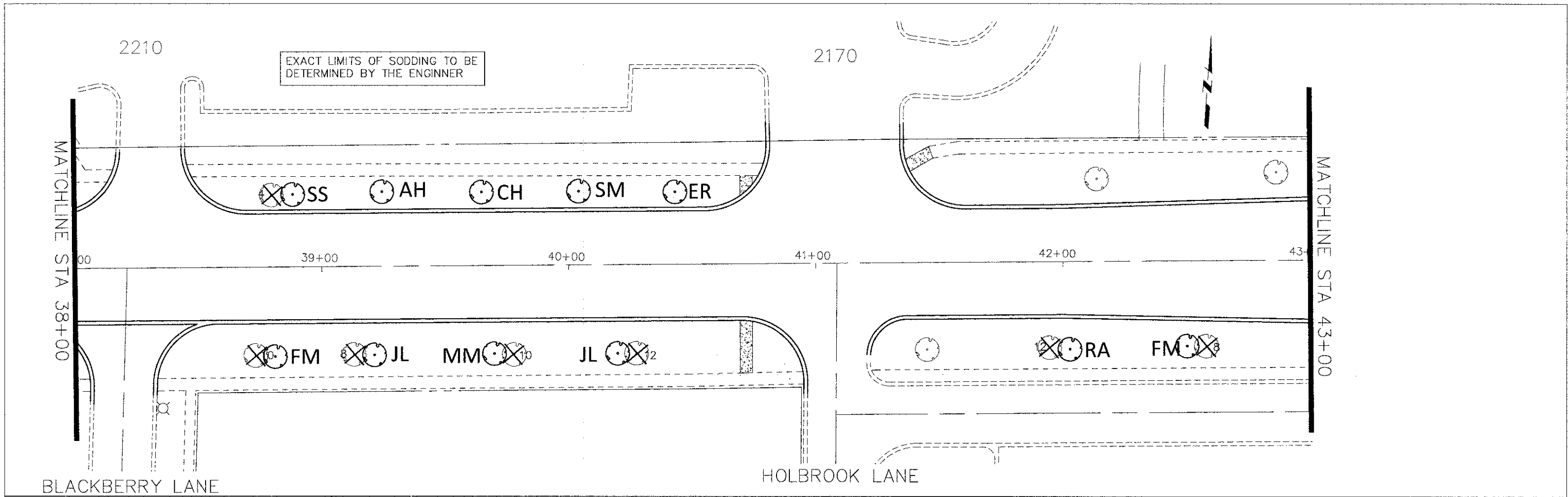

SYMBOL	SPECIES NAME	COMMON NAME	DIAMETER	HEIGHT	UNIT	QUANTITY
CH	CRETAEGUS GRUSGALLI INERMIS	THORNLESS COCKSPUR HAWTHORN		6'	EA	1
ER	CERCIS CANADENSIS	EASTERN REDBUD		6'	EA	1
SM	MAGNOLIA SOULANGIANA	SAUCER MAGNOLIA		6'	EA	1
AH	OSTRYA VIRGINIANA	AMERICAN HOPHORNBEAM	2-1/2"		EA	1
SS	AMELANCHIER CANADENSIS	SHADBLOW SERVICEBERRY		6'	EA	1
MM	ACER MIYABEII MORTON	STATE STREET MIYABE MAPLE	2-1/2"		EA	2
FM	ACER X FREEMANI ARMSTRONG	ARMSTRONG FREEMAN MAPLE	2-1/2"		EA	2
RA	TILIA AMERICANA REDMOND	REDMOND AMERICAN LINDEN	2-1/2"		EA	1
TP	LIRIODENDRON TULIPIFERA	TULIP TREE	2-1/2"		EA	1
JL	SYRINGA RETICULATA	JAPANESE TREE LILAC	2-1/2"		EA	2
EH	CARPINUS BETULUS FASTIGIATA	EUROPEAN HORNBEAM - COLUMNAR	3"		EA	2
KC	GYMNOCLADUS DIOICUS	KENTUCKY COFFEETREE	2-1/2"		EA	1

PLAN	DESIGNED	DATE	BY
	DRAWN		
	CHECKED		
	DATE		
	NO.		

PROFILE	DESIGNED	DATE	BY
	DRAWN		
	CHECKED		
	DATE		
	NO.		

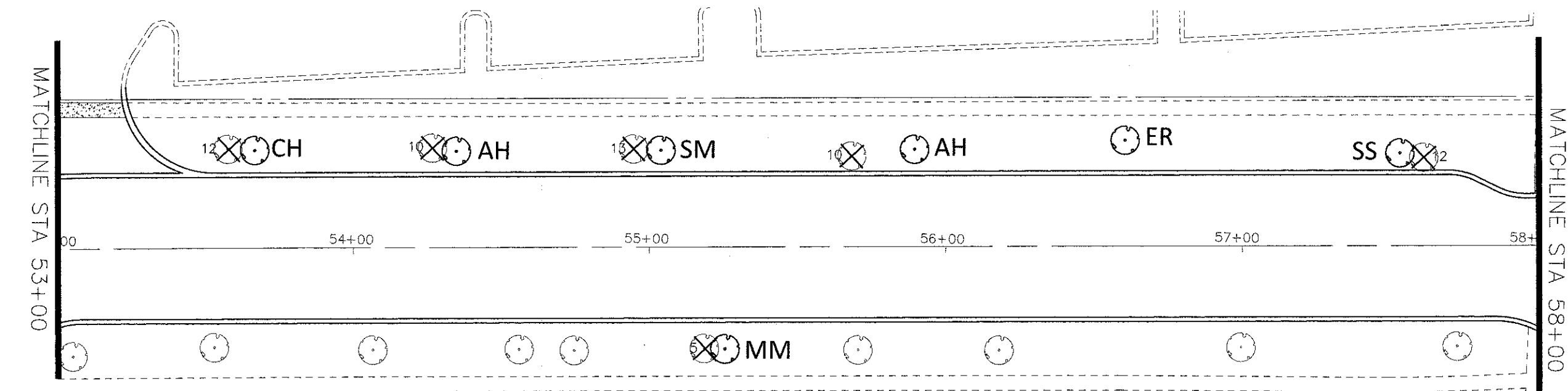
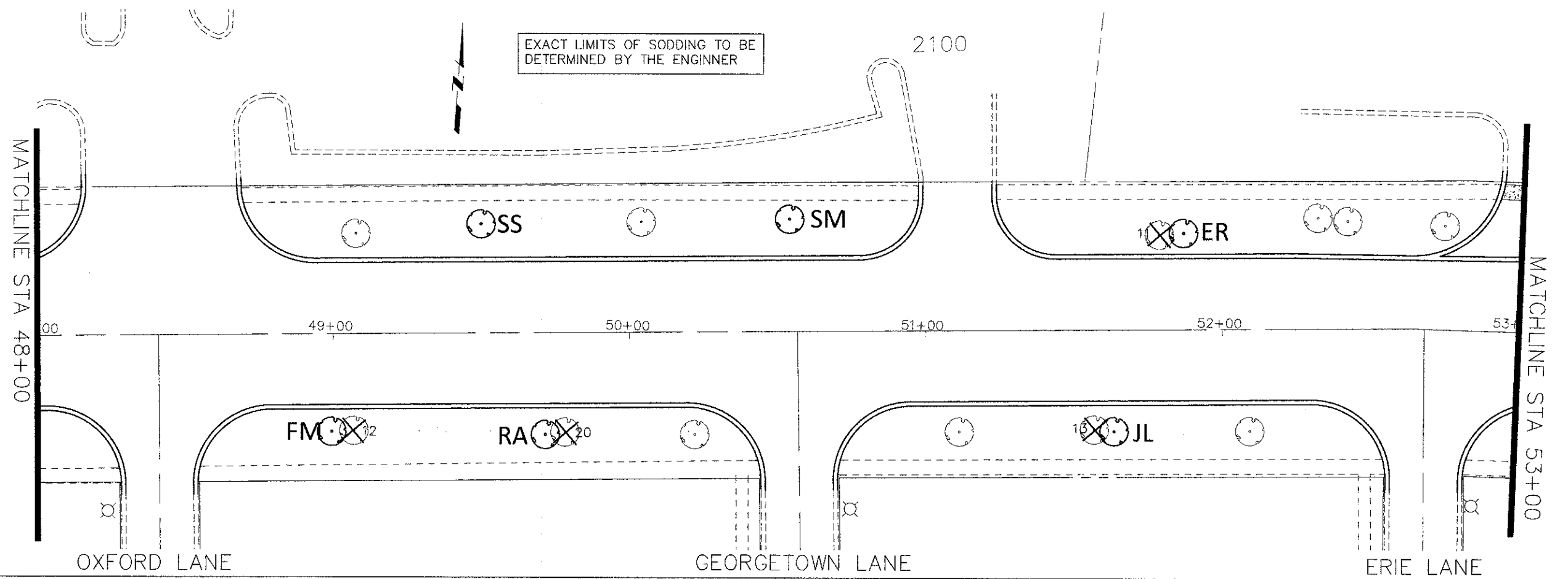

SYMBOL	SPECIES NAME	COMMON NAME	DIAMETER	HEIGHT	UNIT	QUANTITY
CH	CRATAEGUS GRUSGALLI INERMIS	THORNLESS COCKSPUR HAWTHORN	8"	8'	EA	1
ER	CERCIS CANADENSIS	EASTERN REDBUD	8"	8'	EA	2
SM	MAGNOLIA SCULARIGIANA	SALICER MAGNOLIA	6"	8'	EA	2
AH	OSTRYA VIRGINIANA	AMERICAN HOPHORNBEAM	2-1/2"	8'	EA	2
SS	AMELANCHIER CANADENSIS	SHADBLow SERVICEBERRY	6"	8'	EA	2
MM	ACER MIYABEI NORTON	STATE STREET MIYABE MAPLE	2-1/2"	8'	EA	1
FM	ACER X FREEMANII ARMSTRONG	ARMSTRONG FREEMAN MAPLE	2-1/2"	8'	EA	1
RA	TILIA AMERICANA REDMOND	REDMOND AMERICAN LINDEN	2-1/2"	8'	EA	1
TP	LIRIODENDRON TULIPIFERA	TULIP TREE	2-1/2"	8'	EA	1
JL	SYRINGA RETICULATA	JAPANESE TREE LILAC	2-1/2"	8'	EA	1
EH	ICARPINUS BETULUS FASTIGIATA	EUROPEAN HORNBEAM - COLUMNAR	3"	8'	EA	1
KC	GYMNOCLADUS DIOICUS	KENTUCKY COFFEE TREE	2-1/2"	8'	EA	1

PLAN
 SURVEYED
 ALIGNMENT CHECKED
 NO. OF STAKES CHECKED
 NO. OF W.P. CHECKED
 NO. OF COPIES NAME

PROFILE
 SURVEYED
 GRADES CHECKED
 B.M. NOTED
 STRUCTURE NOTATIONS CHD

DATE
 BY
 DATE
 BY
 DATE
 BY

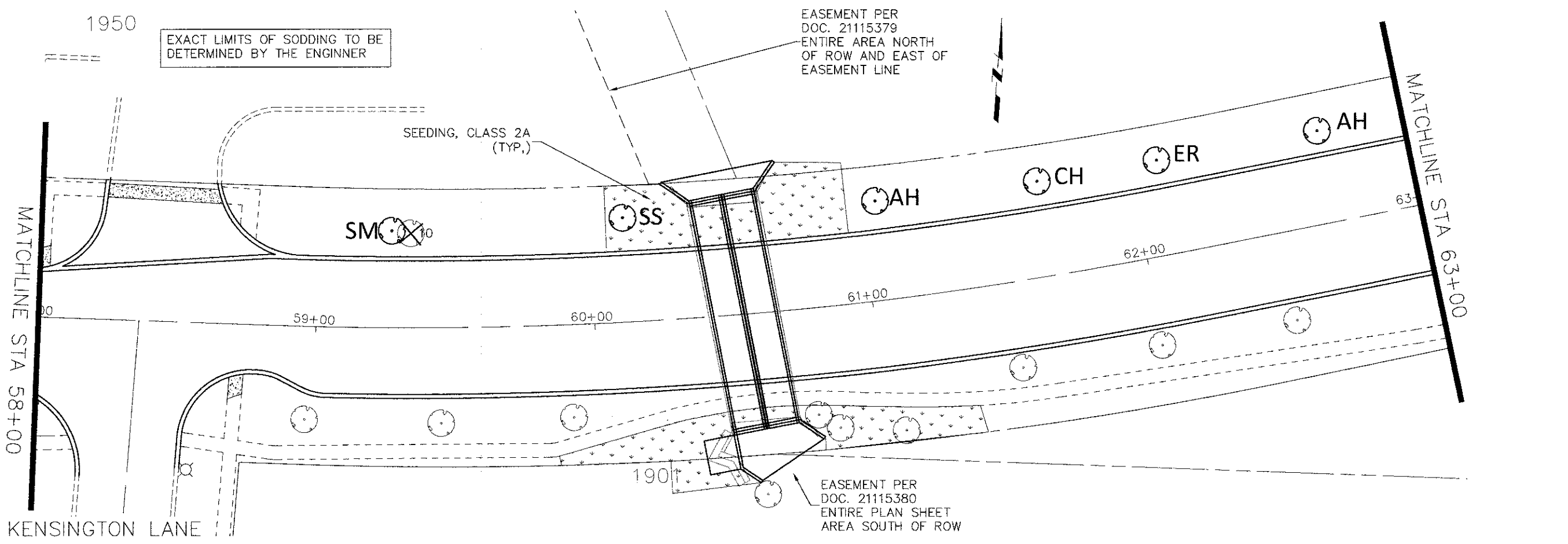

SYMBOL	SPECIES NAME	COMMON NAME	DIAMETER	HEIGHT	UNIT	QUANTITY
CH	CRETAEGUS GRUSGALLI INERMIS	THORNLESS COCKSPUR HAWTHORN	8"	EA		3
ER	CERCIS CANADENSIS	EASTERN REDBUD	8"	EA		2
SM	MAGNOLIA SOULANGIANA	SAUCER MAGNOLIA	8"	EA		2
AH	OSTRYA VIRGINIANA	AMERICAN HOPHORNBEAM	2-1/2"	EA		4
SS	AMELANCHIER CANADENSIS	SHADBLOW SERVICEBERRY	6"	EA		2
MM	ACER MIYABEI MORTON	STATE STREET MIYABE MAPLE	2-1/2"	EA		1
FM	ACER X FREEMANNI ARMSTRONG	ARMSTRONG FREEMAN MAPLE	2-1/2"	EA		1
RA	TILIA AMERICANA REDMOND	REDMOND AMERICAN LINDEN	2-1/2"	EA		1
TP	LIRIODENDRON TULIPIFERA	TULIP TREE	2-1/2"	EA		1
JL	SYRINGA RETICULATA	JAPANESE TREE LILAC	2-1/2"	EA		1
EH	CARPINUS BETULUS FASTIGIATA	EUROPEAN HORNBEAM - COLUMNAR	3"	EA		2
KC	GYMNOCLADUS DIOICUS	KENTUCKY COFFEE TREE	2-1/2"	EA		1

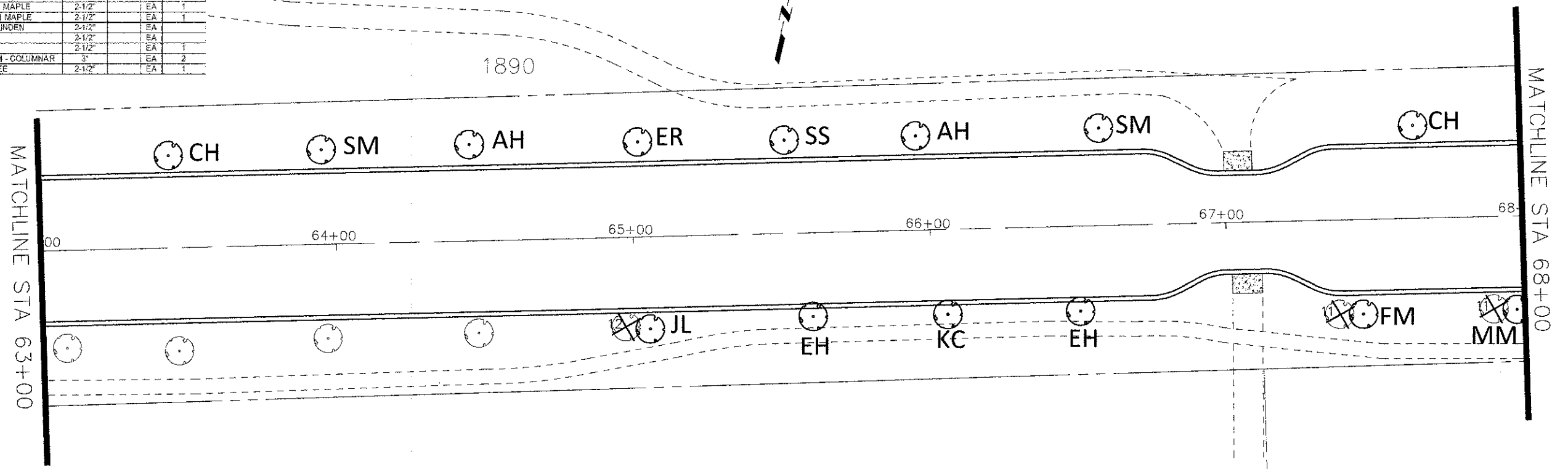

EXACT LIMITS OF SODDING TO BE DETERMINED BY THE ENGINEER

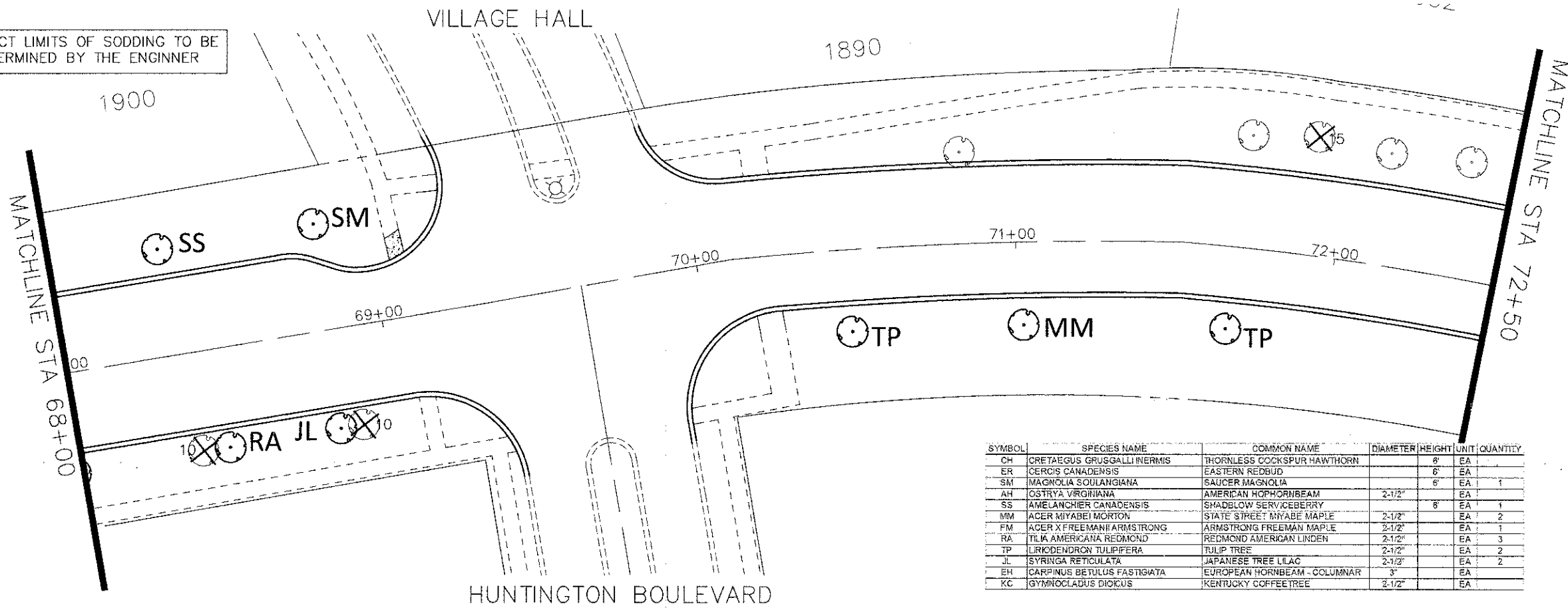

SYMBOL	SPECIES NAME	COMMON NAME	DIAMETER	HEIGHT	UNIT	QUANTITY
CH	CRETAEGUS GRUSGALLI INERMIS	THORNLESS COCKSPUR HAWTHORN		8'	EA	
ER	CERCIS CANADENSIS	EASTERN REDBUD		6'	EA	
SM	MAGNOLIA SOULANGIANA	SAUCER MAGNOLIA		6'	EA	1
AH	OSTRYA VIRGINIANA	AMERICAN HOPHORNBEAM	2-1/2"		EA	
SS	AMELANCHIER CANADENSIS	SHADBLOW SERVICEBERRY		8'	EA	1
MM	ACER MIYABEI MORTON	STATE STREET MIYABE MAPLE	2-1/2"		EA	2
FM	ACER X FREEMANI ARMSTRONG	ARMSTRONG FREEMAN MAPLE	2-1/2"		EA	1
RA	TILIA AMERICANA REGMOND	REDMOND AMERICAN LINDEN	2-1/2"		EA	3
TP	LIRIODENDRON TULIPERA	TULIP TREE	2-1/2"		EA	2
JL	SYRINGA RETICULATA	JAPANESE TREE LILAC	2-1/2"		EA	2
EH	CARPINUS BETULUS FASTIGIATA	EUROPEAN HORNBEAM - COLUMNAR	3"		EA	
KC	GYMNOCLADUS DIOICUS	KENTUCKY COFFEETREE	2-1/2"		EA	

PLAN	SURVEYED	DATE	BY
	ALIGNED		
	CHECKED		
	RT. OF WAY CHECKED		
	NO.		

PARKVIEW CIRCLE (W)

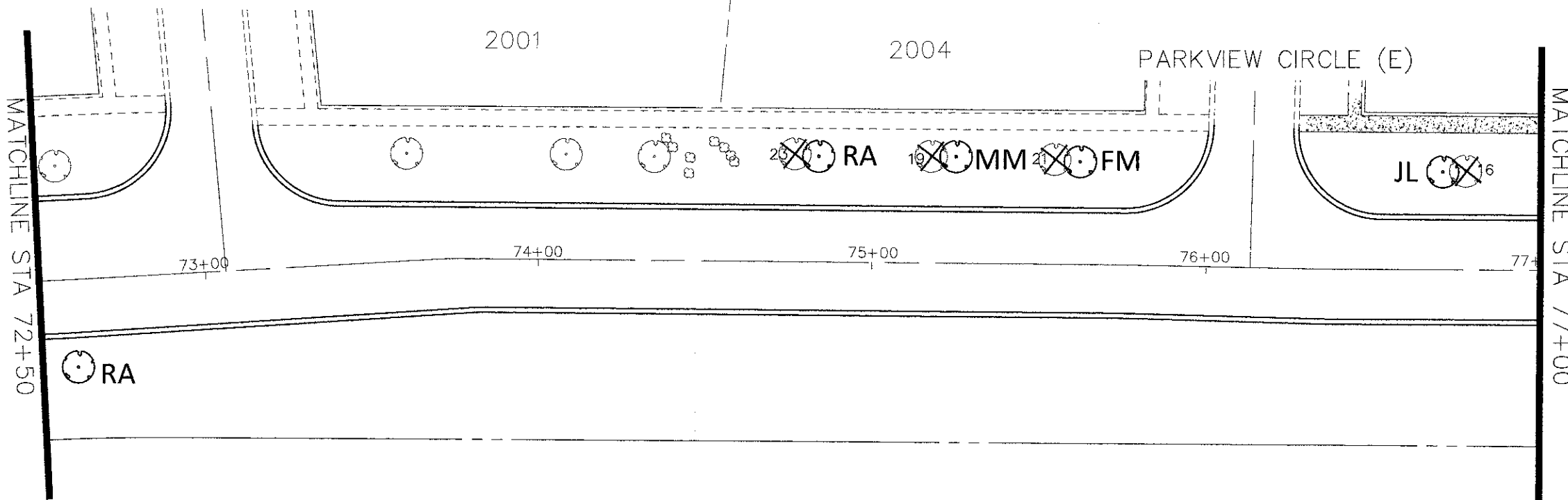

PROFILE	SURVEYED	DATE	BY
	GRADES CHECKED		
	S.M. NOTED		
	STRUCTURE NOTATIONS OK'D		
	NO.		

FILE NAME = Hassell Plan-Profile.dwg

DESIGNED -	REVISED -
DRAWN -	REVISED -
CHECKED -	REVISED -
DATE -	REVISED -

STATE OF ILLINOIS
DEPARTMENT OF TRANSPORTATION

Hassell Road STP Project
Landscaping Plan

SCALE: 1" = 20' SHEET NO. 7 OF 8 SHEETS STA. 68+00 TO STA 77+00

F.A.U. RTE.	SECTION	COUNTY	TOTAL SHEETS	SHEET NO.
1100	11-00087-00-FP	Cook	164	88
CONTRACT NO. 63770			ILLINOIS FED. AID PROJECT CMM 9003(757)	

SYMBOL	SPECIES NAME	COMMON NAME	DIAMETER	HEIGHT	UNIT	QUANTITY
CH	CRETAEGUS GRUSGALLI INERMIS	THORNLESS COCKSPUR HAWTHORN		6'	EA	
ER	CERCIS CANADENSIS	EASTERN REDBUD		8'	EA	
SM	MAGNOLIA SOULANGIANA	SAUCER MAGNOLIA		8'	EA	
AH	OSTRYA VIRGINIANA	AMERICAN HOPHORNBEAM	2-1/2"		EA	
SS	AMELANCHIER CANADENSIS	SHADBLOW SERVICEBERRY		8'	EA	
MM	ACER MIYABEI MORTON	STATE STREET MIYABE MAPLE	2-1/2"		EA	1
FM	ACER X FREEMANII ARMSTRONG	ARMSTRONG FREEMAN MAPLE	2-1/2"		EA	
RA	TILIA AMERICANA REDMOND	REDMOND AMERICAN LINDEN	2-1/2"		EA	1
TP	LIRIODENDRON TULIPIFERA	TULIP TREE	2-1/2"		EA	1
JL	SYRINGA RETICULATA	JAPANESE TREE LILAC	2-1/2"		EA	
EH	CARPINUS BETULUS FASTIGATA	EUROPEAN HORNBEAM - COLUMNAR	3"		EA	
KC	GYMNOCLADUS DIOICUS	KENTUCKY COFFEETREE	2-1/2"		EA	

ROSEDALE LANE

EXACT LIMITS OF SODDING TO BE DETERMINED BY THE ENGINEER

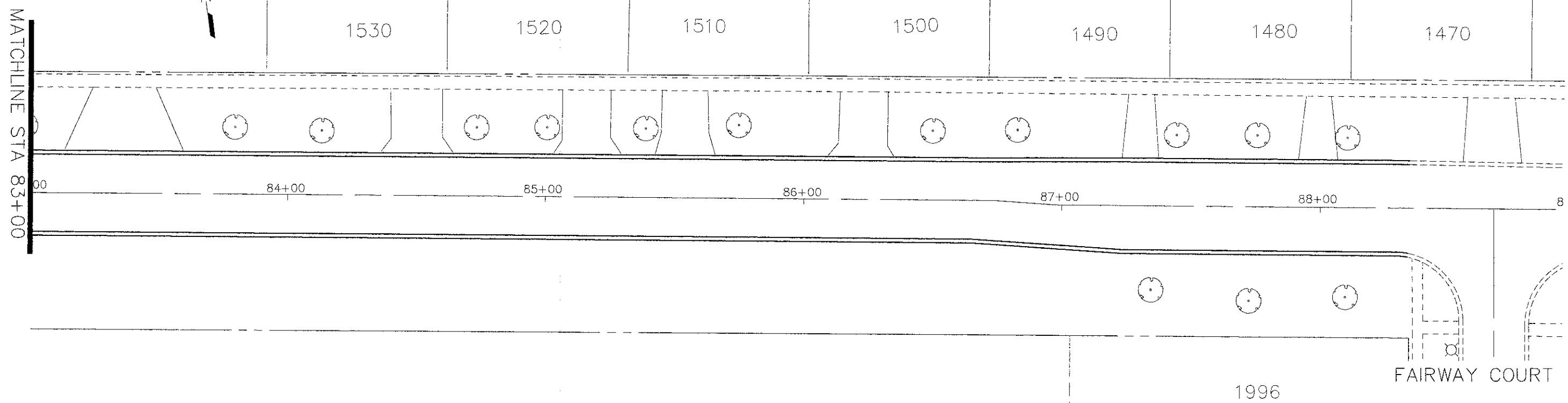
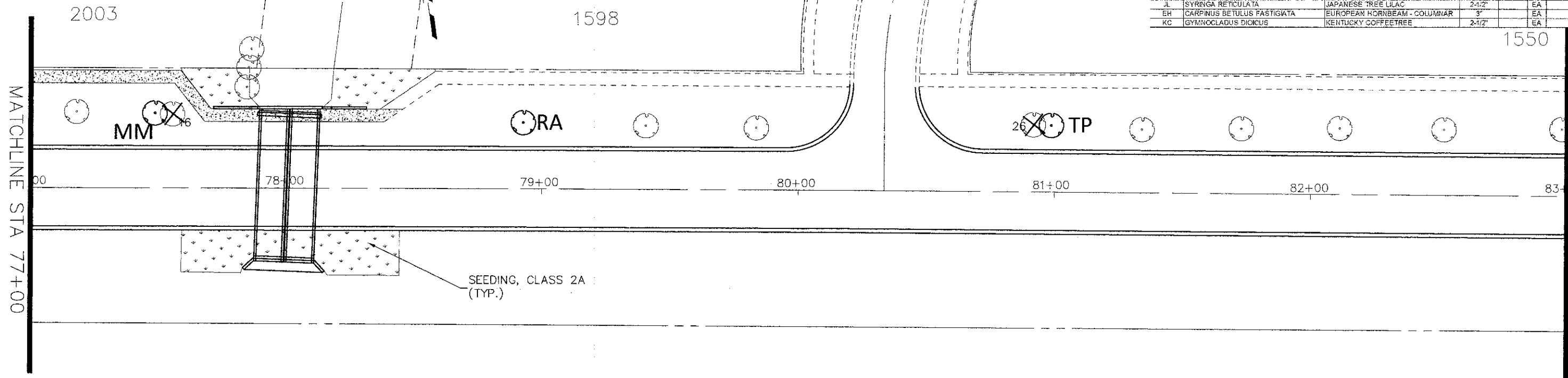

PLAN	SURVEYED	DATE
	NOTE BOOK	
	ALIGNED CHECKED	
	RT. OF WAY CHECKED	
	NO.	
	DATE	
	BY	

PROFILE	SURVEYED	DATE
	NOTE BOOK	
	ALIGNED CHECKED	
	S.M. NOTED	
	STRUCTURE NOTINGS CHD	
	NO.	
	DATE	
	BY	

LOOP DETECTOR NOTES

1. EACH PAIR OF LOOP WIRES SHALL BE PLACED IN A SEPARATE EMPTY COILABLE NONMETALLIC CONDUIT FROM THE EDGE OF PAVEMENT TO THE HANDHOLE. SPACING BETWEEN THE HOLES DRILLED IN THE PAVEMENT SHALL NOT BE LESS THAN 6" (150 mm). EMPTY COILABLE NONMETALLIC CONDUIT SHALL BE INCLUDED IN THE COST OF THE LOOP WIRE.
2. THE NUMBER OF LOOP TURNS SHALL BE AS RECOMMENDED BY THE AMPLIFIER MANUFACTURER. ALL ADJACENT SIDES OF THE LOOPS SHALL BE INSTALLED IN SUCH A WAY THAT THE CURRENT FLOW IS IN THE SAME DIRECTION TO REINFORCE ITS MAGNETIC FIELDS FOR SMALL VEHICLE DETECTION.
3. EACH LOOP LEAD-IN SHALL BE IDENTIFIED AND PERMANENTLY TAGGED IN THE HANDHOLE. EACH LEAD-IN CABLE TAG SHALL INDICATE THE LOCATION OF THE LOOP, LOOP ROTATION (CLOCKWISE/COUNTERCLOCKWISE), LOOP LEAD-IN DIRECTION (IN OR OUT), LOOP CABLE NUMBER AND LOCATION IN CABINET, AND NUMBER OF TURNS IN THE DETECTOR LOOPS IN WATER PROOF INK AS INDICATED ON THE DISTRICT 1 STANDARD TRAFFIC SIGNAL DESIGN DETAIL. THE CONTRACTOR SHALL MARK LOOP LOCATIONS ON RECORD DRAWINGS AND PRESENT TO THE ENGINEER AFTER FINAL INSPECTION. LOOPS SHALL BE MARKED BY LANE AND LOOP NUMBER. SEE DETAIL BELOW.
4. ALL LOOP CABLE SHALL BE FASTENED WITH PLASTIC TIE WRAP TO THE HANDHOLE HOOKS.
5. IN ASPHALT PAVEMENT, LOOPS SHOULD BE PLACED IN THE BINDER AND DIVEHOLES MARKED AT THE CURB WITH A SAW-CUT. THE SAW-CUT SHALL BE CUT IN ACCORDANCE WITH LOCAL AND E.P.A. DUST CONTROL REQUIREMENTS. DETECTOR LOOP(S) SHALL NOT BE INSTALLED IN WET CONDITIONS AND THE SAW-CUTS MUST BE FREE OF DEBRIS AND RESIDUE SUCH AS DUST AND WATER WHICH IS TO BE ACHIEVED BY THE USE OF COMPRESSED AIR, WIRE BRUSHING AND HEAT DRYING ACCORDING TO SEALANT MANUFACTURER REQUIREMENTS. THE DETECTOR WIRE SHALL BE HELD IN PLACE BY THE USE OF FORM WEDGES. WEDGES SHALL BE SPACED NO MORE THAN 18" (450 mm) APART.
6. LOOP SPLICES SHALL BE SOLDERED USING A SOLDERING IRON. BLOW TORCHES OR OTHER DEVICES WHICH OXIDIZE COPPER CABLE SHALL NOT BE ALLOWED FOR SOLDERING OPERATIONS. SEE DETAIL BELOW RIGHT.
7. PREFORMED DETECTOR LOOPS SHALL BE USED, AS SHOWN ON THE PLANS, WHERE NEW CONCRETE PAVEMENT IS PROPOSED. THE INSTALLATION OF PREFORMED LOOPS SHALL BE IN ACCORDANCE WITH THE DISTRICT 1 SPECIFICATIONS OR AS DIRECTED BY THE ENGINEER.

LOOP LEAD-IN CABLE TAG

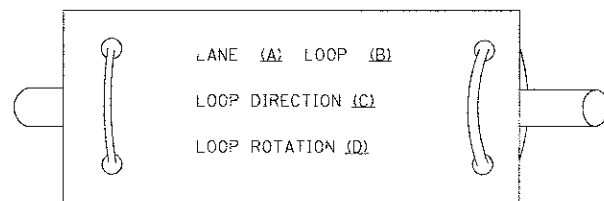

- A. LANE 1 IS THE LANE CLOSEST TO THE CENTERLINE OF THE ROADWAY
- B. LOOP #1 IS THE LOOP IN THE LANE CLOSEST TO THE INTERSECTION.
- C. LABEL LOOP CABLE "IN" OR LOOP CABLE "OUT".
- D. LABEL LOOP CABLE CLOCKWISE OR LOOP CABLE COUNTERCLOCKWISE.

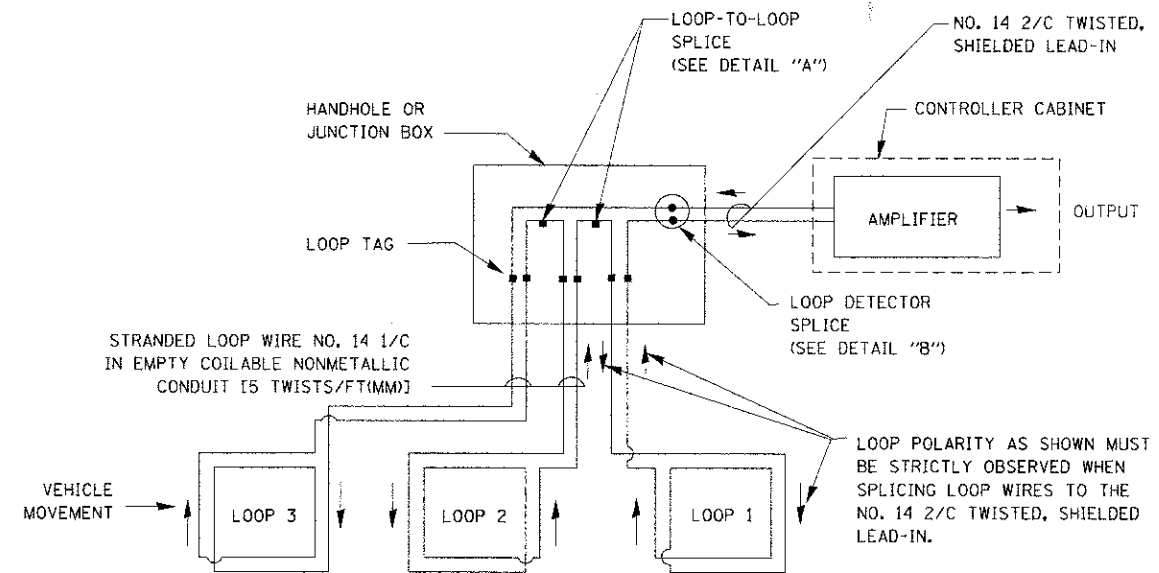

DETECTOR LOOP WIRING SCHEMATIC

- LOOPS SHALL BE SPLICED IN SERIES.
- SAW-CUTS SHALL BE A MINIMUM WIDTH OF 5/16" (8 mm).
- SAW-CUT DEPTHS SHALL BE 3" (75 mm). IF IN CONCRETE, THE SAW-CUT DEPTH SHALL BE TO THE TOP OF THE REINFORCEMENT.
- LOOP CORNERS SHALL BE DRILLED WITH A 2" (50 mm) DIAMETER CORE.

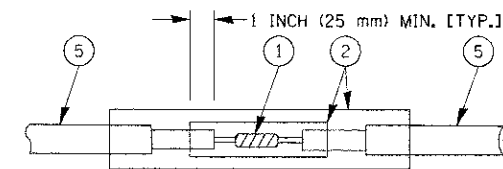

DETAIL "A" LOOP-TO-LOOP SPLICE

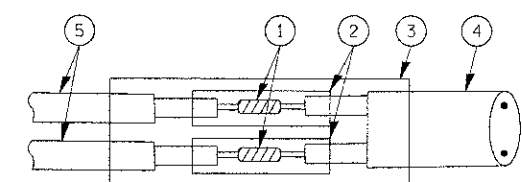

DETAIL "B" LOOP-TO-CONTROLLER SPLICE

TYPE I LOOP

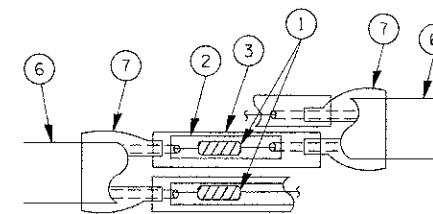

DETAIL "A" LOOP-TO-LOOP SPLICE

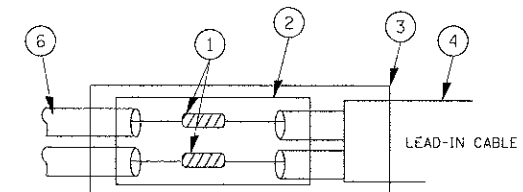

DETAIL "B" LOOP-TO-CONTROLLER SPLICE

LOOP DETECTOR SPLICE

- 1 WESTERN UNION SPLICE SOLDERED WITH ROSIN CORE FLUX. ALL EXPOSED SURFACES OF THE SOLDER SHALL BE SMOOTH.
- 2 WCSMW 30/100 HEAT SHRINK TUBE, MINIMUM LENGTH 3" (75 mm), UNDERWATER GRADE.
- 3 WCS 200/750 HEAT SHRINK TUBE, MINIMUM LENGTH 6" (150 mm), UNDERWATER GRADE.
- 4 NO. 14 2/C TWISTED, SHIELDED CABLE.
- 5 LOOP CONDUCTOR WITH FLEXIBLE PLASTIC TUBE.
- 6 PRE-FORMED LOOP
- 7 XL POLYOLEFIN 2 CONDUCTOR BREAKOUT SEALS. TYCO CBR-2 OR APPROVED EQUAL

FILE NAME =	USER NAME = bauerdi	DESIGNED - DAD	REVISED -	STATE OF ILLINOIS DEPARTMENT OF TRANSPORTATION	DISTRICT ONE STANDARD TRAFFIC SIGNAL DESIGN DETAILS	F.A. RTE. 1100	SECTION 11-00087-00-EP	COUNTY COOK	TOTAL SHEETS 164	SHEET NO. 90	
os:\pwwork\pwwid\Bauerdi\08108310\ts05.dwg	PLOT SCALE = 50.0000 / IN.	DRAWN - BCK	REVISED -			SCALE: NONE	SHEET NO. 1 OF 6 SHEETS	STA.	TO STA.	TS-05	
	PLOT DATE = 11/4/2009	CHECKED - DAD	REVISED -					CONTRACT NO. 83770			
		DATE = 10-28-09	REVISED -					FED. ROAD DIST. NO. 1 [ILLINOIS] FED. AID PROJECT CRR 9003 (757)			

TRAFFIC SIGNAL MAST ARM AND SIGNAL POST

MAST ARM MOUNTED SIGNALS IN EXISTING, PROPOSED OR FUTURE SIDEWALK/BICYCLE PATH AREA. INTERSECTION SHOWN WITH PEDESTRIAN SIGNALS AND PEDESTRIAN PUSHBUTTON DETECTORS.

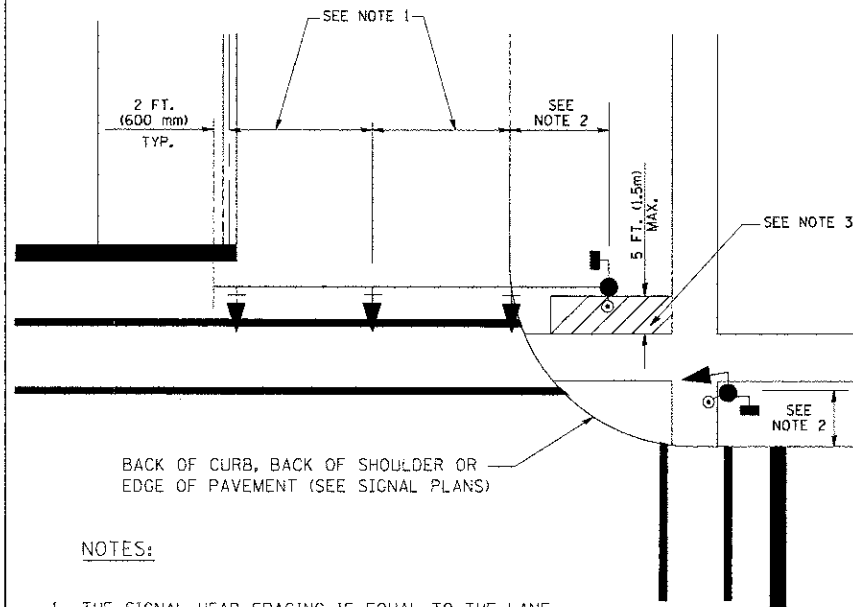

NOTES:

1. THE SIGNAL HEAD SPACING IS EQUAL TO THE LANE WIDTH OR AS SHOWN ON THE TRAFFIC SIGNAL PLAN.
2. REFER TO THE TRAFFIC SIGNAL EQUIPMENT OFFSET TABLE.
3. PROVIDE A LEVEL ALL-WEATHER SURFACE (CONCRETE SIDEWALK, ASPHALT BICYCLE PATH SURFACE OR MATCHING MATERIAL TO THE ADJACENT SURFACE) UP TO THE MAST ARM SHAFT OR THE SIGNAL POST.
4. THE FACE OF THE PEDESTRIAN PUSHBUTTON SHALL BE PARALLEL TO THE CROSSWALK TO BE USED.
5. THE LOCATIONS AND INSTALLATION OF PEDESTRIAN SIGNAL HEADS AND PEDESTRIAN PUSHBUTTONS SHALL MEET THE REQUIREMENTS OF THE MUTCD AND INFORMATION FOUND IN THE "AMERICANS WITH DISABILITIES ACT ACCESSIBILITY GUIDELINES FOR BUILDINGS AND FACILITIES."

PEDESTRIAN SIGNAL POST AND PEDESTRIAN PUSH BUTTON POST

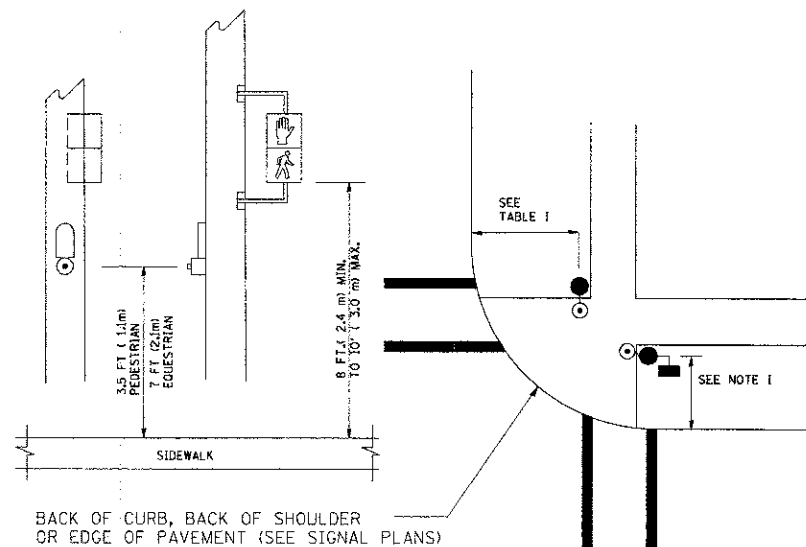

NOTES:

1. REFER TO THE TRAFFIC SIGNAL EQUIPMENT OFFSET TABLE.
2. PROVIDE A LEVEL ALL-WEATHER SURFACE (CONCRETE SIDEWALK, ASPHALT BICYCLE PATH SURFACE OR MATCHING MATERIAL TO THE ADJACENT SURFACE) UP TO THE PEDESTRIAN SIGNAL POST OR THE PEDESTRIAN PUSH BUTTON POST.
3. THE FACE OF THE PEDESTRIAN PUSHBUTTON SHALL BE PARALLEL TO THE CROSSWALK TO BE USED.
4. THE LOCATIONS AND INSTALLATION OF PEDESTRIAN SIGNAL HEADS AND PEDESTRIAN PUSHBUTTONS SHALL MEET THE REQUIREMENTS OF THE MUTCD AND INFORMATION FOUND IN THE "AMERICANS WITH DISABILITIES ACT ACCESSIBILITY GUIDELINES FOR BUILDINGS AND FACILITIES."

RECOMMENDED PUSHBUTTON LOCATIONS

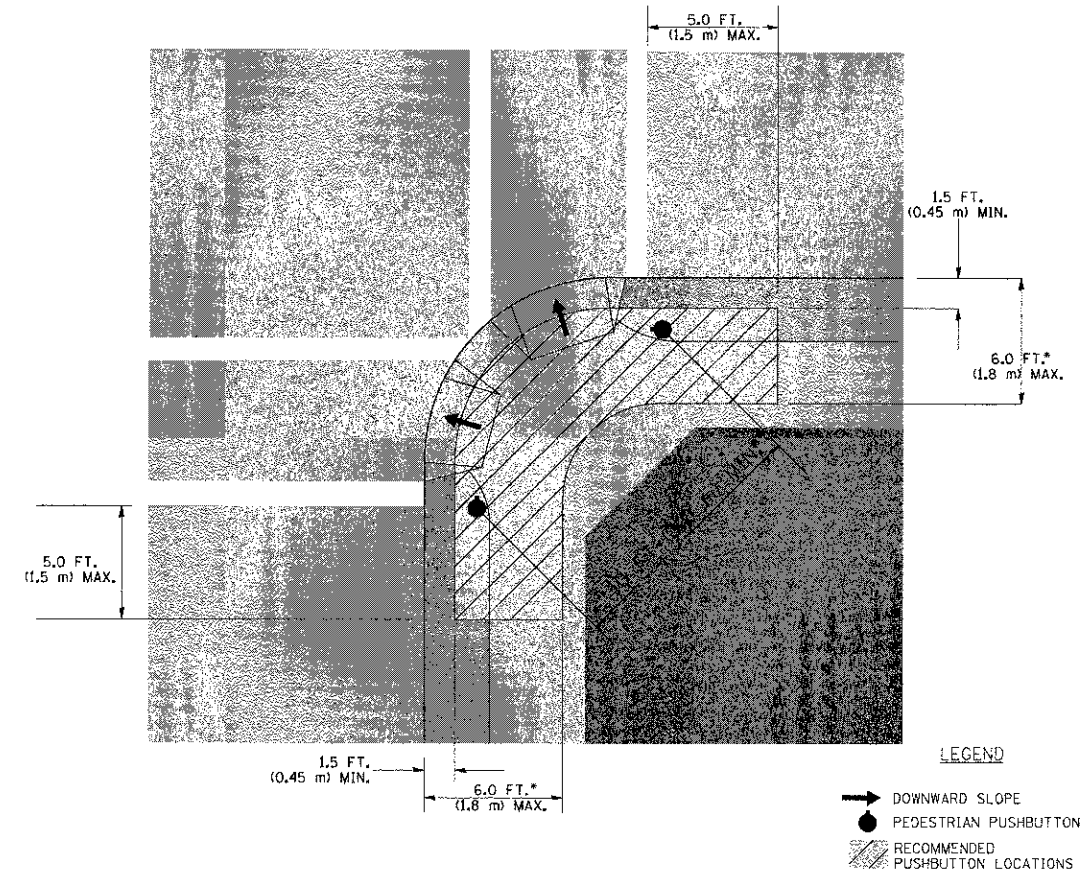

- WHERE THERE ARE CONSTRAINTS THAT MAKE IT IMPRACTICAL TO PLACE THE PEDESTRIAN PUSHBUTTON BETWEEN 1.5 FT (0.45 m) AND 6 FT (1.8 m) FROM THE EDGE OF THE CURB, SHOULDER, OR PAVEMENT, IT SHOULD NOT BE FURTHER THAN 10 FT (3 m) FROM THE EDGE OF CURB, SHOULDER, OR PAVEMENT.
- WHERE THERE ARE CONSTRAINTS ON A PARTICULAR CORNER THAT MAKE IT IMPRACTICAL TO PROVIDE THE 10 FT (3 m) SEPERATION BETWEEN THE TWO PEDESTRIAN PUSHBUTTONS, THE PUSHBUTTONS MAY BE PLACED CLOSER TOGETHER OR ON THE SAME POLE.

NOTES:

1. PEDESTRIAN SIGNAL HEADS SHALL BE MOUNTED WITH THE BOTTOM OF THE SIGNAL HOUSING INCLUDING BRACKETS NOT LESS THAN 8 FT (2.4 m) OR MORE THAN 10 FT (3 m) ABOVE SIDEWALK LEVEL, AND SHALL BE POSITIONED AND ADJUSTED TO PROVIDE MAXIMUM VISIBILITY AT THE BEGINNING OF THE CONTROLLED CROSSWALK.
2. THE BOTTOM OF THE SIGNAL HOUSING (INCLUDING BRACKETS) OF A VEHICULAR SIGNAL FACE THAT IS NOT LOCATED OVER A HIGHWAY SHALL BE AT LEAST 8 FT (2.4 m) BUT NOT MORE THAN 19 FT (5.8 m) ABOVE THE SIDEWALK OR, IF THERE IS NO SIDEWALK, ABOVE THE PAVEMENT GRADE AT THE CENTER OF THE ROADWAY.
3. THE BOTTOM OF THE SIGNAL HOUSING AND ANY RELATED ATTACHMENTS TO A SIGNAL FACE LOCATED OVER ANY PORTION OF A HIGHWAY SHALL BE ACCORDING TO CURRENT STATE STANDARDS 877001, 877002, 877006, 877011 AND 877012 WITH A MINIMUM OF 16 FT (5.0 m) AND A MAXIMUM OF 18 FT. (5.5 m) FROM THE HIGHEST POINT OF PAVEMENT.
4. THE BOTTOM OF THE TEMPORARY SPAN WIRE MOUNTED SIGNAL HOUSING AND ANY RELATED ATTACHMENTS TO A SIGNAL FACE LOCATED OVER ANY PORTION OF A HIGHWAY SHALL BE ACCORDING TO CURRENT STATE STANDARD 880001 WITH A MINIMUM OF 17 FT (5.18 m) FROM THE HIGHEST POINT OF PAVEMENT.
5. THE TOP OF THE SIGNAL HOUSING OF A SIGNAL FACE LOCATED OVER ANY PORTION OF A HIGHWAY SHALL NOT BE MORE THAN 25.6 FT (7.8 m) ABOVE THE PAVEMENT.

TRAFFIC SIGNAL EQUIPMENT OFFSET

TRAFFIC SIGNAL EQUIPMENT	COMBINATION CONCRETE CURB AND GUTTER (MINIMUM DISTANCE FROM BACK OF CURB TO CENTERLINE OF FOUNDATION)	SHOULDER/NON-CURBED AREA (MINIMUM DISTANCE FROM EDGE OF PAVEMENT TO CENTERLINE OF FOUNDATION)
TRAFFIC SIGNAL MAST ARM POLE	6 FT (1.8m)	SHOULDER WIDTH + 2 FT (0.6m), MINIMUM 10 FT (3.0m)
TRAFFIC SIGNAL POST	4 FT (1.2m)	SHOULDER WIDTH + 2 FT (0.6m), MINIMUM 10 FT (3.0m)
PEDESTRIAN SIGNAL POST	4 FT (1.2m)	SHOULDER WIDTH + 2 FT (0.6m), MINIMUM 10 FT (3.0m)
PEDESTRIAN PUSHBUTTON POST	4 FT (1.2m)	SHOULDER WIDTH + 2 FT (0.6m), MINIMUM 10 FT (3.0m)
TEMPORARY WOOD POLE	6 FT (1.8m)	SHOULDER WIDTH + 2 FT (0.6m), MINIMUM 10 FT (3.0m)
CONTROLLER CABINET	6 FT (1.8m) MINIMUM DISTANCE SEE NOTE 2	SHOULDER WIDTH + 6 FT (1.8m), MINIMUM 16 FT (4.9m) SEE NOTE 3.
SERVICE INSTALLATION, GROUND MOUNT	6 FT (1.8m) MINIMUM DISTANCE SEE NOTE 2	SHOULDER WIDTH + 6 FT (1.8m), MINIMUM 16 FT (4.9m) SEE NOTE 3.

NOTES:

1. CONTACT THE "AREA TRAFFIC SIGNAL MAINTENANCE AND OPERATIONS ENGINEER" FOR ASSISTANCE IN LOCATING THE TRAFFIC SIGNAL EQUIPMENT WHEN THERE ARE CONFLICTS WITH DITCHES OR THE MINIMUM OFFSET DISTANCES CANNOT BE MET.
2. MINIMUM DISTANCE FROM THE BACK OF CURB TO THE ROADWAY SIDE OF THE FOUNDATION.
3. MINIMUM DISTANCE FROM THE EDGE OF PAVEMENT TO THE ROADWAY SIDE OF THE FOUNDATION.
4. ANY CHANGES TO THE OFFSETS OF THE FOUNDATIONS, FROM THE MINIMUM DISTANCES LISTED IN THE "TRAFFIC SIGNAL EQUIPMENT OFFSET" CHART AND THE TRAFFIC SIGNAL INSTALLATION PLAN, COULD EFFECT THE PLACEMENT OF THE SIGNAL HEADS, PEDESTRIAN SIGNAL HEADS AND THE PEDESTRIAN PUSHBUTTONS. THE SIGNAL HEAD PLACEMENT ON THE MAST ARMS SHALL REMAIN AS PER THE TRAFFIC SIGNAL INSTALLATION PLAN AND THE "TRAFFIC SIGNAL MAST ARM AND SIGNAL POST" DETAIL ABOVE. THE PROPOSED MAST ARM LENGTHS MAY NEED TO BE REVISED TO MEET THE ABOVE REQUIREMENTS. THE PEDESTRIAN SIGNAL HEADS AND PEDESTRIAN PUSHBUTTONS MUST MEET THE REQUIREMENTS UNDER THE DETAILS ON THIS SHEET.

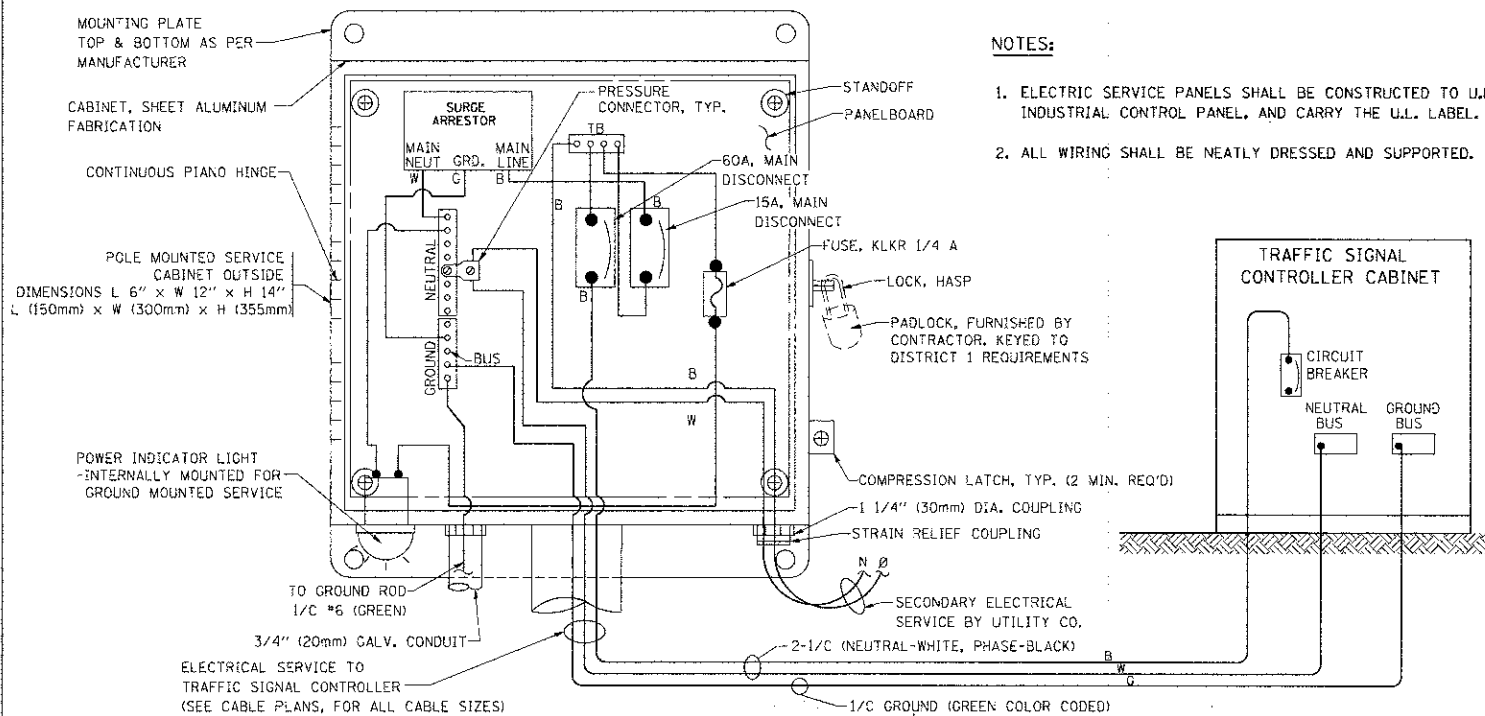

ELECTRICAL SERVICE - PANEL DIAGRAM (TYPICAL FOR POLE AND GROUND MOUNTED SERVICE)
SERVICE INSTALLATION POLE MOUNT (SHOWN)
 (NOT TO SCALE)

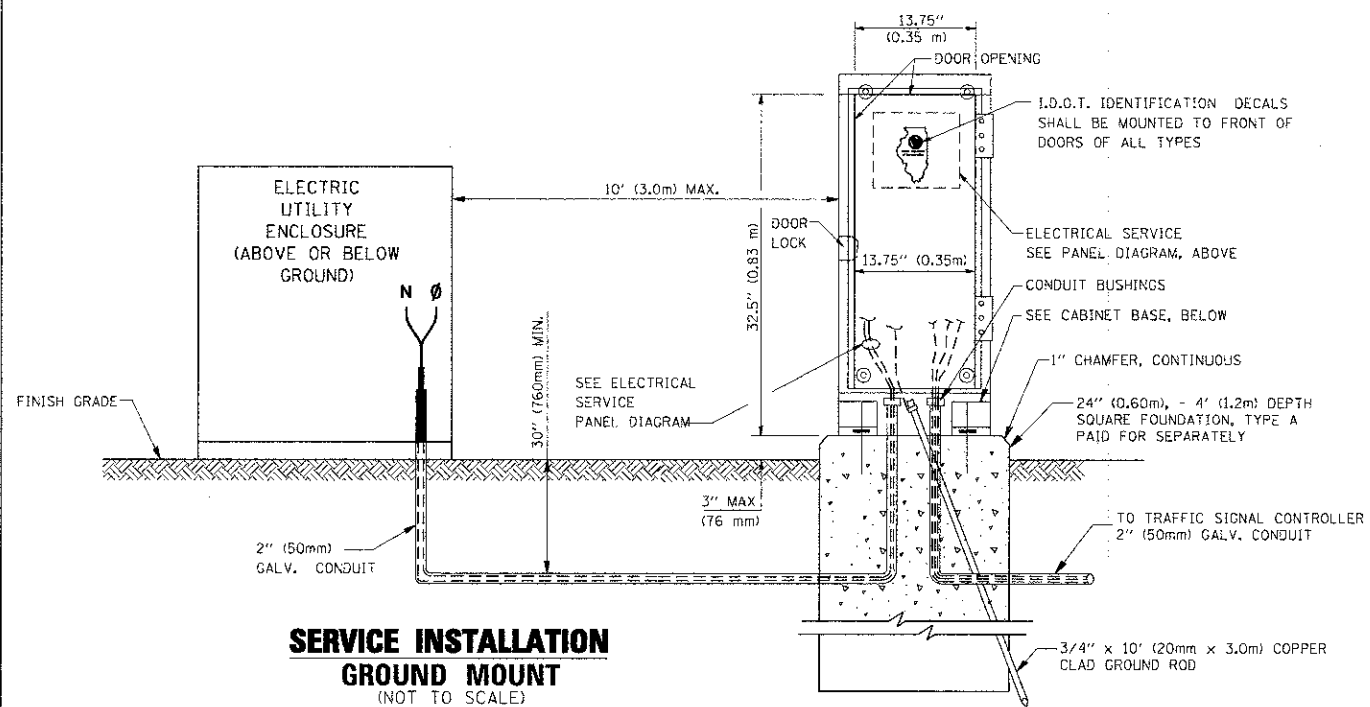

SERVICE INSTALLATION GROUND MOUNT
 (NOT TO SCALE)

CABINET - BASE BOLT PATTERN
 (NOT TO SCALE)

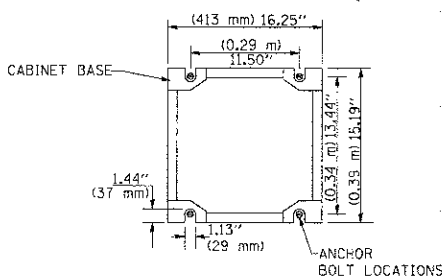

- NOTES:**
1. ELECTRIC SERVICE PANELS SHALL BE CONSTRUCTED TO U.L. STD 508, INDUSTRIAL CONTROL PANEL, AND CARRY THE U.L. LABEL.
 2. ALL WIRING SHALL BE NEATLY DRESSED AND SUPPORTED.

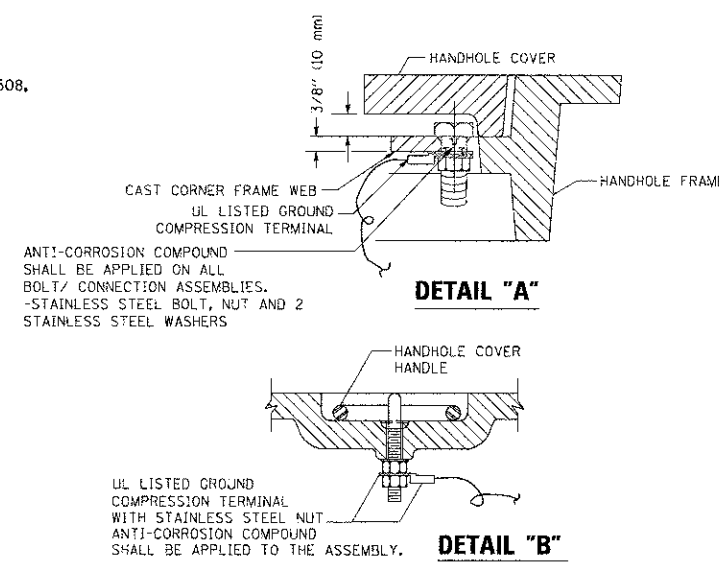

HANDHOLE COVER & FRAME - GROUNDING DETAIL
 (NOT TO SCALE)

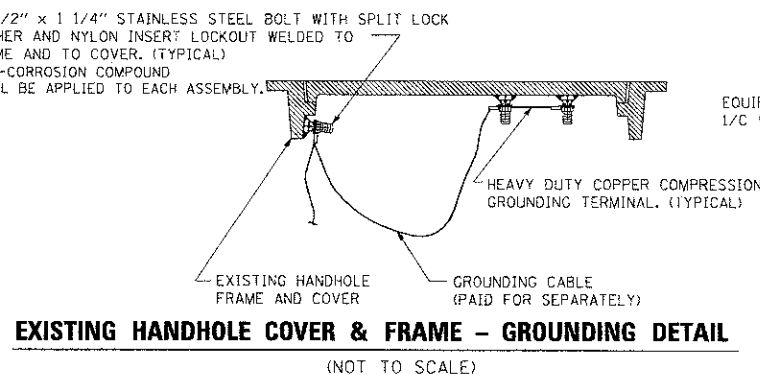

EXISTING HANDHOLE COVER & FRAME - GROUNDING DETAIL
 (NOT TO SCALE)

- NOTES:**
- GROUNDING SYSTEM**
1. THE GROUNDING SYSTEM SHALL CONSIST OF AN INSULATED CONDUCTOR TYPE XLP, NO. 6 A.W.G., STRANDED COPPER TO BE INSTALLED IN RACEWAYS. THE GROUNDING CABLE SHALL BE INSTALLED IN A CONTINUOUS MANNER AS SHOWN ON THE CABLE PLAN PROVIDED. ALL GROUNDING CONDUCTORS SHALL BE BONDED TO METAL ENCLOSURE (HANDHOLE, POST, MAST ARM, CONTROLLER, ETC.). GROUND ROD SHALL BE 3/4\"/>
 - 2. THE NEUTRAL CONDUCTOR AND THE GROUND CONDUCTOR SHALL BE CONNECTED IN THE SERVICE INSTALLATION. AT NO OTHER POINT IN THE TRAFFIC SIGNAL SYSTEM SHALL THE NEUTRAL AND GROUND CONDUCTORS BE CONNECTED.
 - 3. ALL EQUIPMENT GROUNDING CONDUCTORS SHALL TERMINATE AT THE GROUND BUS IN THE CONTROLLER CABINET.
 - 4. THE CONTRACTOR SHALL PROVIDE A GROUND CABLE WITH CONNECTORS BETWEEN THE HANDHOLE COVER AND HANDHOLE FRAME.

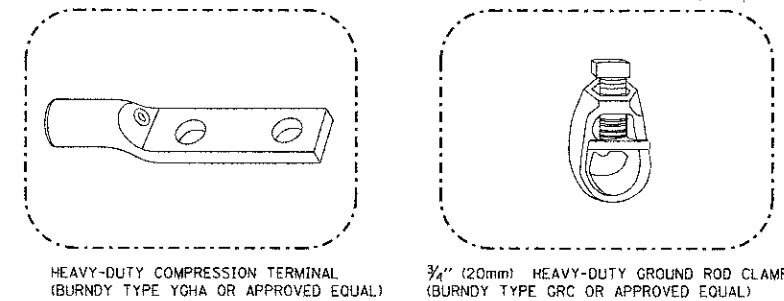

- NOTES:**
- ALL CLAMPS SHALL BE BRONZE OR COPPER, U.L. APPROVED.
 - GROUND CABLE SHALL BE LOOPED OVER HOOKS IN THE HANDHOLES 6.5' (2.0m) SLACK SHALL BE PROVIDED IN SINGLE HANDHOLES 13' (4.0m) OF SLACK SHALL BE PROVIDED IN DOUBLE HANDHOLES. 5' (1.4m) OF SLACK SHALL BE PROVIDED BETWEEN FRAME AND COVER.

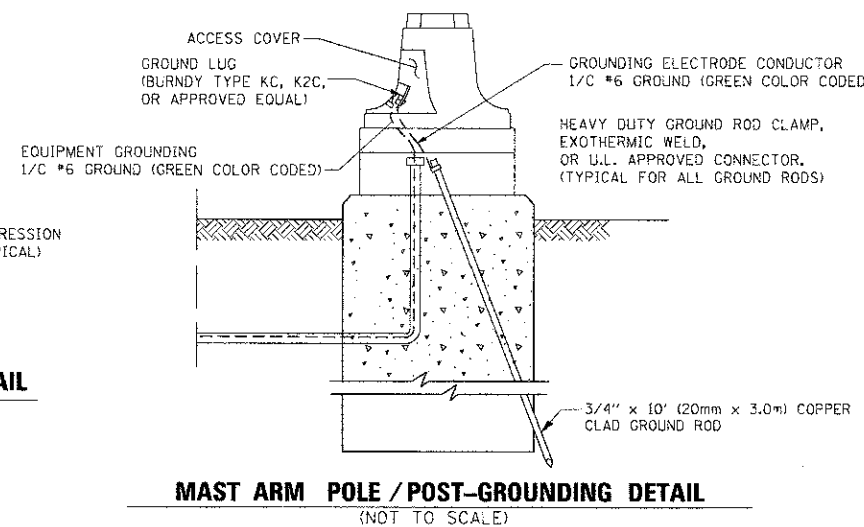

MAST ARM POLE / POST-GROUNDING DETAIL
 (NOT TO SCALE)

FILE NAME =	USER NAME = bauerd	DESIGNED - DAD	REVISED -	STATE OF ILLINOIS DEPARTMENT OF TRANSPORTATION	DISTRICT ONE STANDARD TRAFFIC SIGNAL DESIGN DETAILS	F.A. R.E.	SECTION	COUNTY	TOTAL SHEETS	SHEET NO.
as:\pwork\pwork\DOT\BAUERDL\0106315\1105	DRAWN - BCK	REVISED -	1100			11-00087-00-FP	COOK	164	92	
PLOT SCALE = 50.0000 / 1 IN.	CHECKED - DAD	REVISED -	TS-05			CONTRACT NO. 63770				
PLOT DATE = 11/4/2009	DATE - 10-28-09	REVISED -	SCALE: NONE			SHEET NO. 3 OF 6 SHEETS	STA. TO STA.	FED. ROAD DIST. NO. 1 ILLINOIS FED. AID PROJECT CMM 9003 (757)		

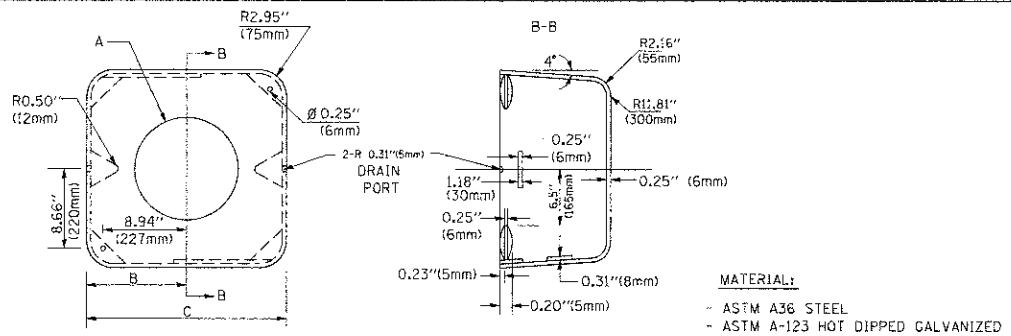
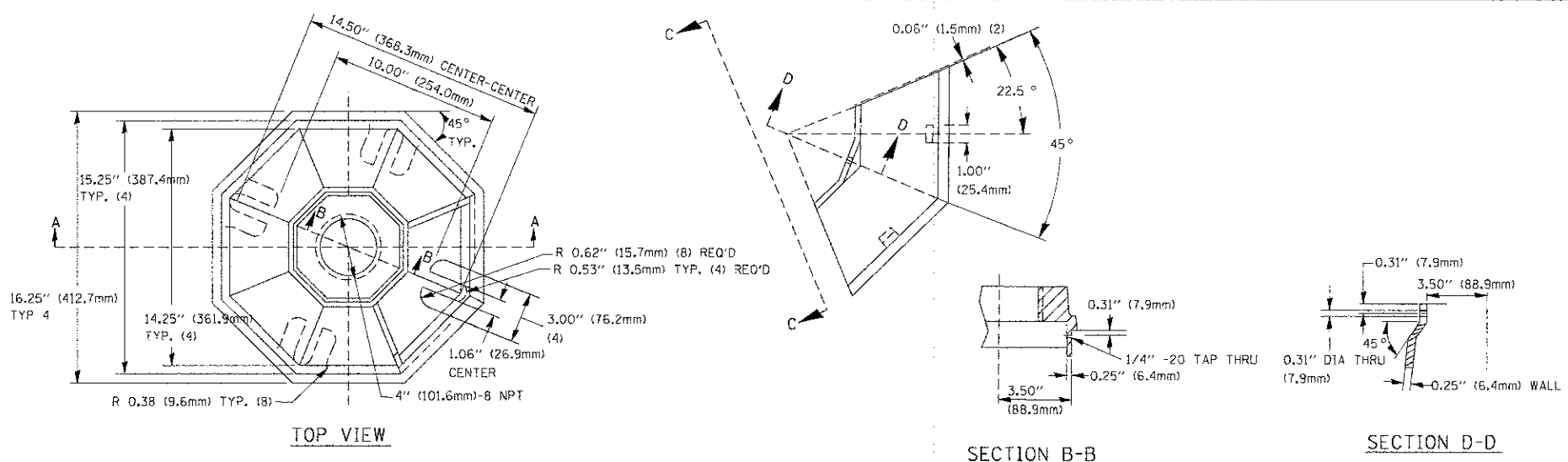

A	B	C	HEIGHT	WEIGHT
VARIES	9.5" (241mm)	19" (483mm)	7" (178mm) - 12" (300mm)	53 lbs (24kg)
VARIES	10.75" (273mm)	21.5" (546mm)	7" (178mm) - 12" (300mm)	68 lbs (31 kg)
VARIES	13.0" (330mm)	26" (660mm)	7" (178mm) - 12" (300mm)	81 lbs (37 kg)
VARIES	18.5" (470mm)	37" (940mm)	7" (178mm) - 12" (300mm)	126 lbs (57 kg)

MATERIAL:
 - ASTM A36 STEEL
 - ASTM A-123 HOT DIPPED GALVANIZED

SHROUD

NOTES:

1. DIMENSION "A" IS EQUAL TO THE DIAMETER OF THE MAST ARM POLE AT THE TOP OF THE SHROUD. THE SHROUD SHALL BE TIGHT TO THE MAST ARM POLE.
2. THE SUPPLIER SHALL VERIFY THE ABOVE DIMENSIONS BASED ON MAST ARM REQUIREMENTS.
3. THE HEIGHT OF THE SHROUD SHALL COVER THE ANCHOR BOLTS, NUTS AND MAST ARM POLE BASE.

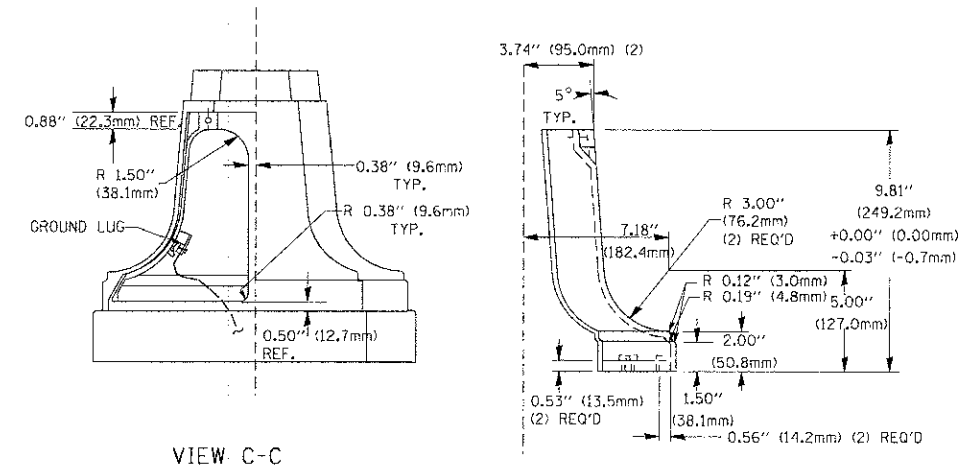
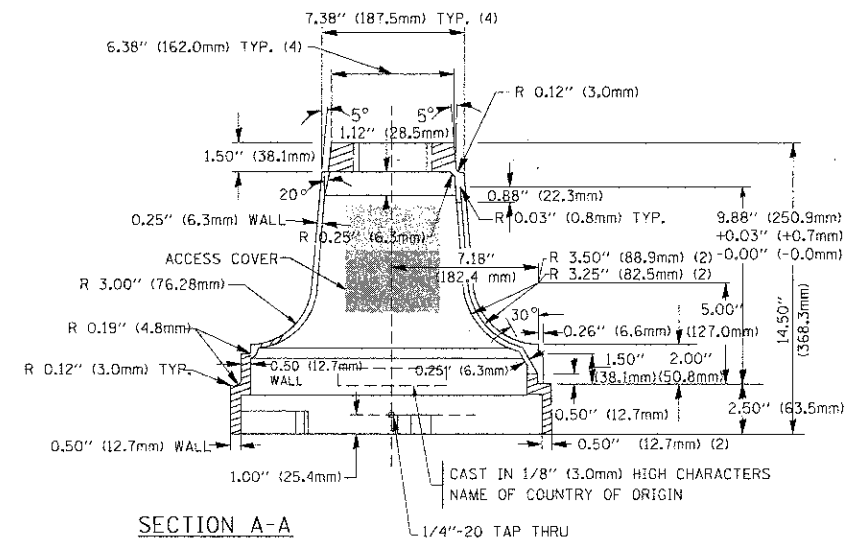

TRAFFIC SIGNAL POST - MOUNTING BASE - TYPE A

NOTE:

SUPPORT EXISTING CABINET AND CONTROL EQUIPMENT ABOVE FOUNDATION TO KEEP TRAFFIC SIGNAL FUNCTIONING WHILE FOUNDATION MODIFICATION WORK IS PROCEEDING.

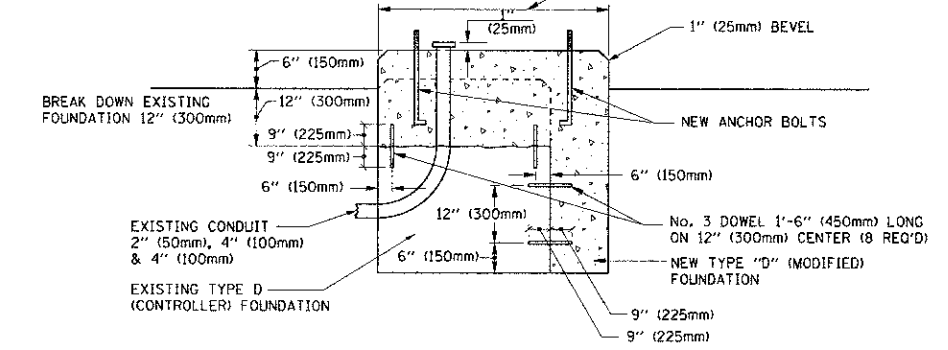

MODIFY EXISTING TYPE "D" FOUNDATION

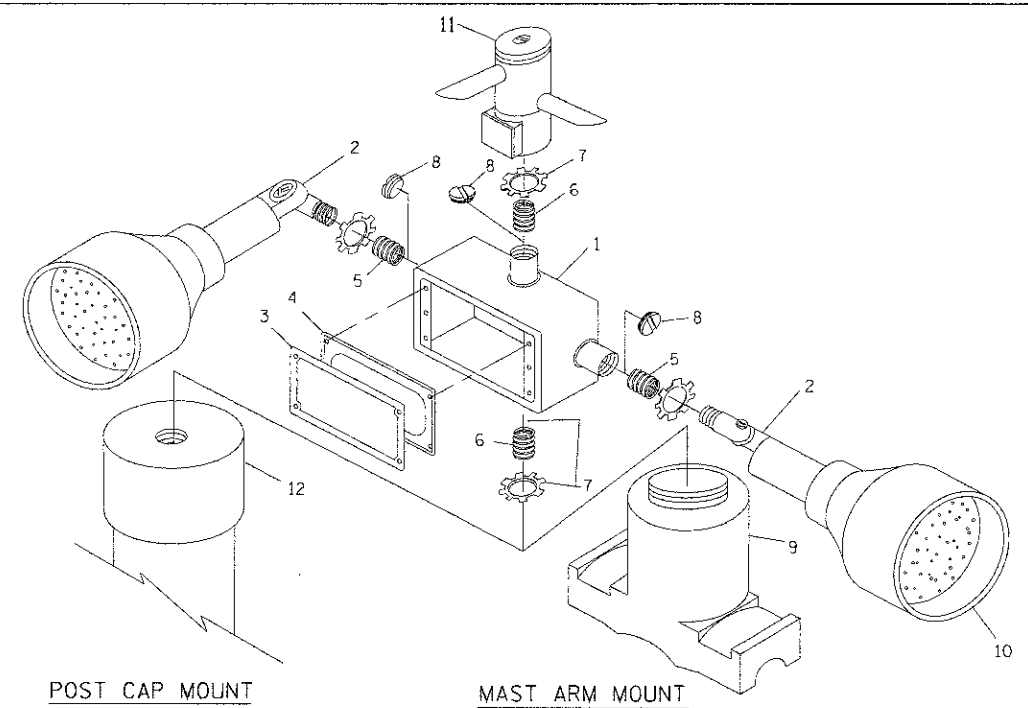

ITEM NO.	IDENTIFICATION
1	OUTLET BOX - GALV. 21 CU. IN. (0.000344 CU-M)
2	LAMP HOLDER AND COVER
3	OUTLET BOX COVER
4	RUBBER COVER GASKET
5	REDUCING BUSHING
6	3/4" (19 mm) CLOSE NIPPLE
7	3/4" (19 mm) LOCKNUT
8	3/4" (19 mm) HOLE PLUG
9	SADDLE BRACKET - GALV.
10	6 WATT PAR 38 LED FLOOD LAMP
11	DETECTOR UNIT
12	POST CAP (18 FT. (5.4 m) POST MIN.)

NOTES:

1. ALL ELECTRICAL ITEMS, EXCEPT ITEMS #2 AND #11 SHALL BE ALUMINUM OR GALVANIZED
2. ITEM #1- OZ/GEDNEY FSX-1-50 OR EQUIVALENT
 ITEM #2- MULBERRY CON-O-SHADE LAMP SHIELD OR EQUIVALENT
 ITEM #9- "BAND-IT" SADDLE BRACKET OR EQUIVALENT
3. WHEN POST MOUNTING IS SPECIFIED, ITEM #9 SHALL NOT BE REQUIRED. THE DETECTION UNIT SHALL BE MOUNTED DIRECTLY ON TOP OF THE CAP BY DRILLING AND TAPPING A 3/4" (19 mm) HOLE WITH PIPE THREADS. THE POST CAP SHALL EITHER BE SCREWED TO THE TOP OF THE POST OR A MINIMUM OF 3 TIGHTENING SCREWS SHALL BE REQUIRED ON EACH CAP.

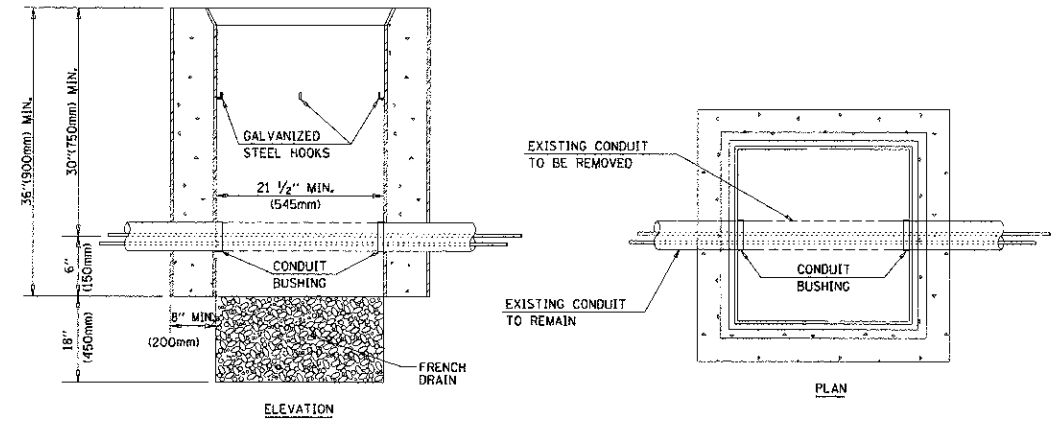

NOTES:

1. HANDHOLE CONSTRUCTED PER STATE STANDARD 814001.
2. REMOVAL OF THE EXISTING CONDUIT FROM THE HANDHOLE AND THE INSTALLATION OF THE CONDUIT BUSHINGS SHALL BE INCIDENTAL TO THE HANDHOLE.

HANDHOLE TO INTERCEPT EXISTING CONDUIT

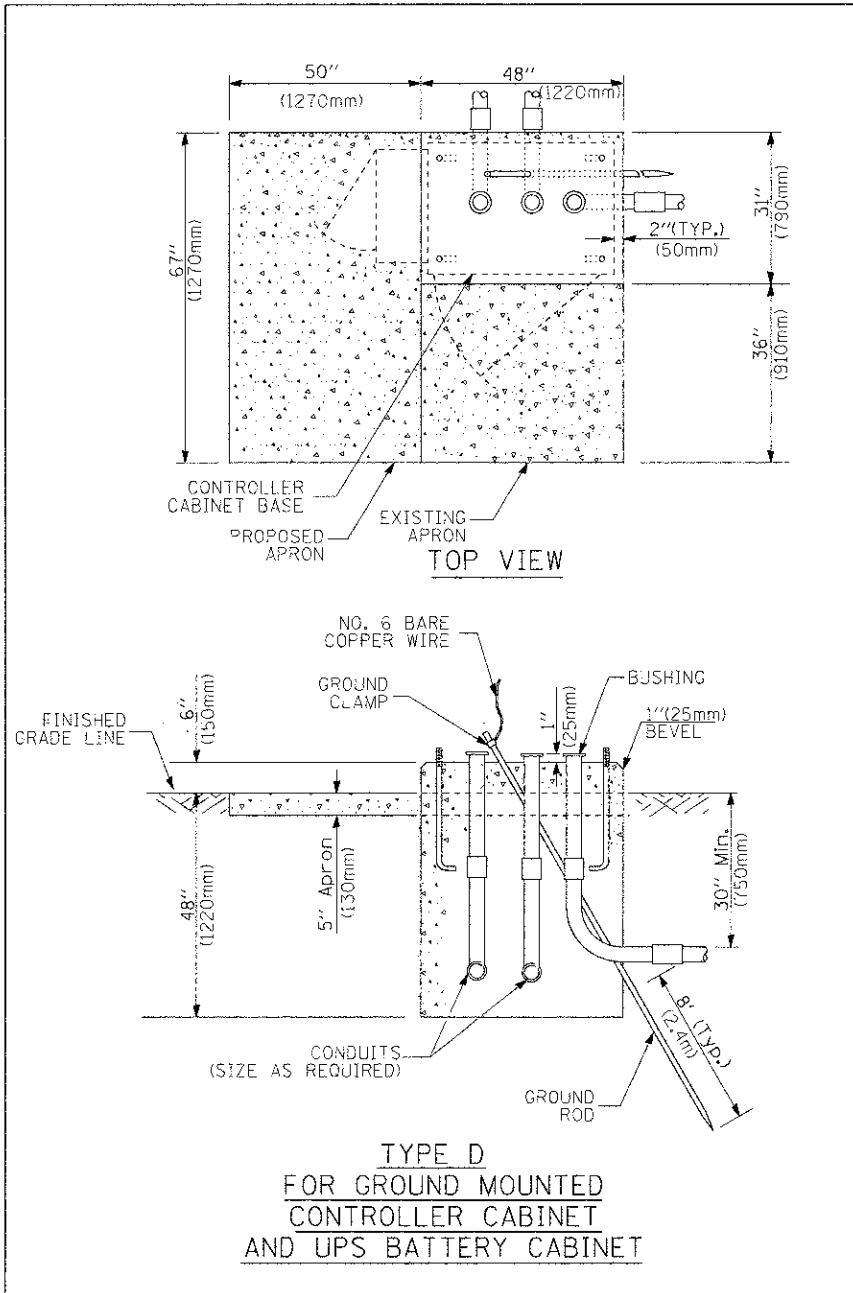

**TYPE D
FOR GROUND MOUNTED
CONTROLLER CABINET
AND UPS BATTERY CABINET**

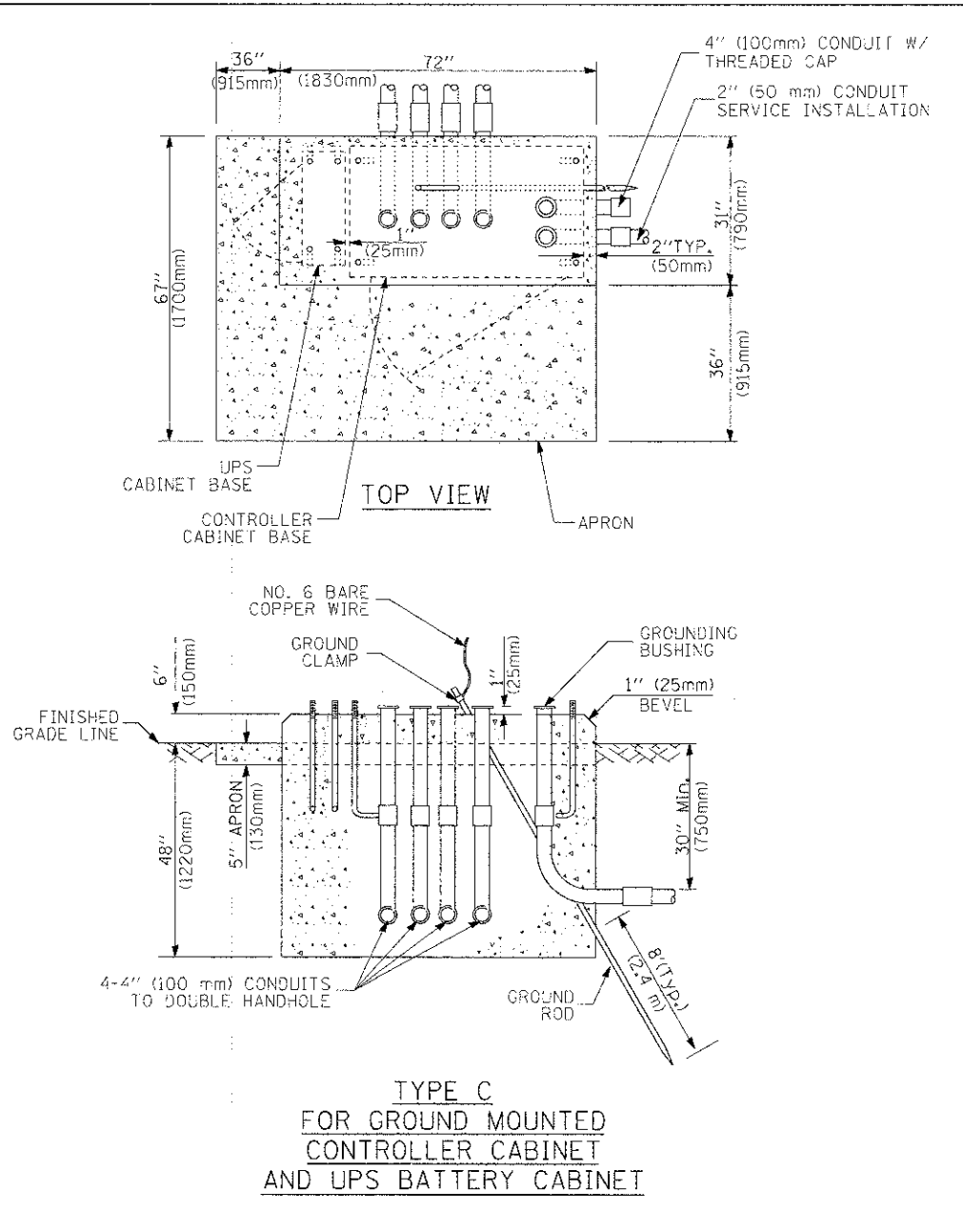

**TYPE C
FOR GROUND MOUNTED
CONTROLLER CABINET
AND UPS BATTERY CABINET**

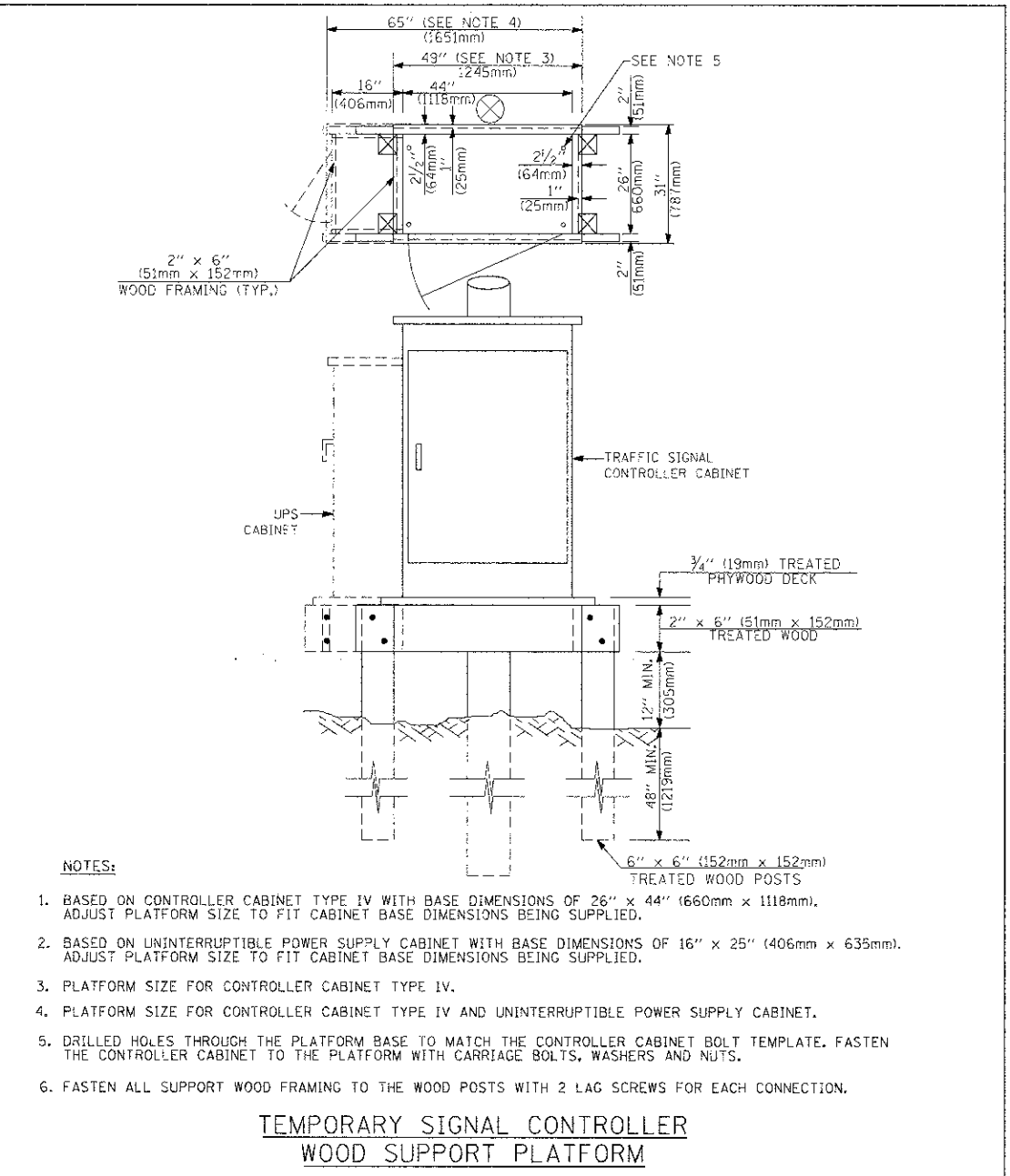

- NOTES:**
1. BASED ON CONTROLLER CABINET TYPE IV WITH BASE DIMENSIONS OF 26" x 44" (660mm x 1118mm). ADJUST PLATFORM SIZE TO FIT CABINET BASE DIMENSIONS BEING SUPPLIED.
 2. BASED ON UNINTERRUPTIBLE POWER SUPPLY CABINET WITH BASE DIMENSIONS OF 16" x 25" (406mm x 635mm). ADJUST PLATFORM SIZE TO FIT CABINET BASE DIMENSIONS BEING SUPPLIED.
 3. PLATFORM SIZE FOR CONTROLLER CABINET TYPE IV.
 4. PLATFORM SIZE FOR CONTROLLER CABINET TYPE IV AND UNINTERRUPTIBLE POWER SUPPLY CABINET.
 5. DRILLED HOLES THROUGH THE PLATFORM BASE TO MATCH THE CONTROLLER CABINET BOLT TEMPLATE. FASTEN THE CONTROLLER CABINET TO THE PLATFORM WITH CARRIAGE BOLTS, WASHERS AND NUTS.
 6. FASTEN ALL SUPPORT WOOD FRAMING TO THE WOOD POSTS WITH 2 LAG SCREWS FOR EACH CONNECTION.

**TEMPORARY SIGNAL CONTROLLER
WOOD SUPPORT PLATFORM**

CABLE SLACK LENGTH	FEET	METER
HANDHOLE	6.5	2.0
DOUBLE HANDHOLE	13.0	4.0
SIGNAL POST	2.0	0.6
MAST ARM	2.0	0.6
CONTROLLER CABINET	1.5	0.5
FIBER OPTIC AT CABINET	13.0	4.0
ELECTRIC SERVICE AT (CABINET OR SERVICE LOCATION)	1.5	0.5
GROUND CABLE (SIGNAL POST, MAST ARM, CABINET)	1.5	0.5
GROUND CABLE (BETWEEN FRAME AND COVER)	5.0	1.6

CABLE SLACK

VERTICAL CABLE LENGTH	FEET	METER
MAST ARM POLE (MAST ARM MOUNTED SIGNAL HEAD) (L = MAST ARM LENGTH - DISTANCE TO SIGNAL HEAD FROM END OF ARM)	20.0+L	6.0+L
BRACKET MOUNTED (MAST ARM POLE OR SIGNAL POLE)	13.0	4.0
PEDESTRIAN PUSH BUTTON	6.0	2.0
SERVICE INSTALLATION POLE MOUNT TO SERVICE DROP	13.5	4.1
SERVICE INSTALLATION POLE MOUNT TO GROUND	13.5	4.1
SERVICE INSTALLATION GROUND MOUNT	6.0	2.0
FOUNDATION (SIGNAL POST, MAST ARM POLE, CONTROLLER CABINET, SERVICE-GROUND MOUNT)	3.0	1.0

VERTICAL CABLE LENGTH

FOUNDATION	DEPTH
TYPE A - Signal Post	4'-0" (1.2m)
TYPE C - CONTROLLER W/ UPS	4'-0" (1.2m)
TYPE D - CONTROLLER	4'-0" (1.2m)
SERVICE INSTALLATION, GROUND MOUNT, TYPE A - SQUARE	4'-0" (1.2m)

DEPTH OF FOUNDATION

MAST ARM LENGTH	FOUNDATION DEPTH	FOUNDATION DIAMETER	SPIRAL DIAMETER	QUANTITY OF REBARS	SIZE OF REBARS
Less than 30' (9.1 m)	10'-0" (3.0 m)	30" (750mm)	24" (600mm)	8	6(19)
Greater than or equal to 30' (9.1 m) and less than 40' (12.2 m)	13'-6" (4.1 m)	30" (750mm)	24" (600mm)	8	6(19)
Greater than or equal to 40' (12.2 m) and less than 50' (15.2 m)	11'-0" (3.4 m)	36" (900mm)	30" (750mm)	12	7(22)
Greater than or equal to 50' (15.2 m) and up to 55' (16.8 m)	13'-0" (4.0 m)	36" (900mm)	30" (750mm)	12	7(22)
Greater than or equal to 55' (16.8 m) and up to 65' (19.8 m)	15'-0" (4.6 m)	36" (900mm)	30" (750mm)	12	7(22)
Greater than or equal to 65' (19.8 m) and less than 75' (22.9 m)	21'-0" (6.4 m)	42" (1060mm)	36" (900mm)	16	8(25)
Greater than or equal to 75' (22.9 m)	25'-0" (7.6 m)	42" (1060mm)	36" (900mm)	16	8(25)

- NOTES:**
1. These foundation depths are for sites which have cohesive soils (clayey silt, sandy clay, etc.) along the length of the shaft, with an average Unconfined Compressive Strength (Qu) > 1.0 tsf (100 kpa). This strength shall be verified by boring data prior to construction or with testing by the Engineer during foundation drilling. The Bureau of Bridges & Structures should be contacted for a revised design if other conditions are encountered.
 2. Combination mast arm assemblies under 55 feet (16.8 m) shall use 36" (900 mm) diameter foundations.
 3. Combination mast arm assemblies under 56 feet (16.8 m) through 75 feet (22.9 m) shall use 42" (1060 mm) diameter foundations.
 4. For mast arm assemblies with dual arms refer to state standard 878001.

DEPTH OF MAST ARM FOUNDATIONS, TYPE E

TRAFFIC SIGNAL LEGEND

ITEM	REMOVAL	EXISTING	PROPOSED	ITEM	REMOVAL	EXISTING	PROPOSED	ITEM	REMOVAL	EXISTING	PROPOSED
CONTROLLER CABINET				EMERGENCY VEHICLE LIGHT DETECTOR				ELECTRIC CABLE IN CONDUIT, TRACER, NO. 14 1/C, UNLESS NOTED OTHERWISE			
RAILROAD CONTROL CABINET				CONFIRMATION BEACON				COAXIAL CABLE			
COMMUNICATIONS CABINET				HANDHOLE				VENDOR CABLE FOR CAMERA			
MASTER CONTROLLER				HEAVY DUTY HANDHOLE				COPPER INTERCONNECT CABLE, NO. 18 3 PAIR TWISTED, SHIELDED			
MASTER MASTER CONTROLLER				DOUBLE HANDHOLE				FIBER OPTIC CABLE NO. 62.5/125, MM12F			
UNINTERRUPTIBLE POWER SUPPLY				JUNCTION BOX				FIBER OPTIC CABLE NO. 62.5/125, MM12F SM12F			
SERVICE INSTALLATION, (P) POLE OR (G) GROUND MOUNT				GALVANIZED STEEL CONDUIT IN TRENCH (T) OR PUSHED (P)				FIBER OPTIC CABLE NO. 62.5/125, MM12F			
TELEPHONE CONNECTION (P) POLE OR (G) GROUND MOUNT				TEMPORARY SPAN WIRE, TETHER WIRE, AND CABLE				FIBER OPTIC CABLE NO. 62.5/125, (NUMBER OF FIBERS & TYPE TO BE NOTED ON PLANS)			
STEEL MAST ARM ASSEMBLY AND POLE				COMMON TRENCH				GROUND ROD AT (C) CONTROLLER, (H) HANDHOLE, (P) POST, (M) MAST ARM, OR (S) SERVICE			
ALUMINUM MAST ARM ASSEMBLY AND POLE				COILABLE NONMETALLIC CONDUIT (EMPTY)				CONTROLLER CABINET AND FOUNDATION TO BE REMOVED			
STEEL COMBINATION MAST ARM ASSEMBLY AND POLE WITH LUMINAIRE				SYSTEM ITEM		S	S	STEEL MAST ARM POLE AND FOUNDATION TO BE REMOVED			
STEEL COMBINATION MAST ARM ASSEMBLY AND POLE WITH PTZ CAMERA				INTERSECTION ITEM		I	IP	ALUMINUM MAST ARM POLE AND FOUNDATION TO BE REMOVED			
SIGNAL POST				REMOVE ITEM	R			STEEL COMBINATION MAST ARM ASSEMBLY AND POLE WITH LUMINAIRE AND FOUNDATION TO BE REMOVED			
TEMPORARY WOOD POLE (CLASS 5 OR BETTER) 45 FOOT (13.7m) MINIMUM				RELOCATE ITEM	RL			SIGNAL POST AND FOUNDATION TO BE REMOVED			
GUY WIRE				ABANDON ITEM	A			INTERSECTION & SAMPLING (SYSTEM) DETECTOR			
SIGNAL HEAD				12" (300mm) TRAFFIC SIGNAL SECTION				SAMPLING (SYSTEM) DETECTOR			
SIGNAL HEAD CONSTRUCTION STAGES (NUMBERS INDICATE THE CONSTRUCTION STAGE)				12" (300mm) RED WITH 8" (200mm) YELLOW AND GREEN TRAFFIC SIGNAL FACE				EXISTING INTERSECTION LOOP DETECTOR			
SIGNAL HEAD WITH BACKPLATE				SIGNAL FACE				PROPOSED INTERSECTION AND SAMPLING (SYSTEM) DETECTOR			
SIGNAL HEAD OPTICALLY PROGRAMMED				SIGNAL FACE WITH BACKPLATE, "P" INDICATES PROGRAMMED HEAD				EXISTING PREFORMED INTERSECTION LOOP DETECTOR			
FLASHER INSTALLATION (S DENOTES SOLAR POWER)				12" (300mm) PEDESTRIAN SIGNAL HEAD WALK/DON'T WALK SYMBOL				PROPOSED INTERSECTION AND SAMPLING (SYSTEM) DETECTOR			
PEDESTRIAN SIGNAL HEAD				12" (300mm) PEDESTRIAN SIGNAL HEAD INTERNATIONAL SYMBOL, OUTLINED				PREFORMED INTERSECTION AND SAMPLING (SYSTEM) DETECTOR			
PEDESTRIAN PUSHBUTTON DETECTOR				12" (300mm) PEDESTRIAN SIGNAL HEAD INTERNATIONAL SYMBOL, SOLID				PREFORMED SAMPLING (SYSTEM) DETECTOR			
ACCESSIBLE PEDESTRIAN PUSHBUTTON DETECTOR				PEDESTRIAN SIGNAL HEAD, INTERNATIONAL SYMBOL, WITH COUNTDOWN TIMER							
ILLUMINATED SIGN "NO LEFT TURN"				RADIO INTERCONNECT							
ILLUMINATED SIGN "NO RIGHT TURN"				RADIO REPEATER							
DETECTOR LOOP, TYPE I				DENOTES NUMBER OF CONDUCTORS, ELECTRIC CABLE NO. 14, UNLESS NOTED OTHERWISE, ALL DETECTOR LOOP CABLE TO BE SHIELDED							
PREFORMED DETECTOR LOOP				GROUND CABLE IN CONDUIT NO. 6 SOLID COPPER (GREEN)							
MICROWAVE VEHICLE SENSOR											
VIDEO DETECTION CAMERA											
VIDEO DETECTION ZONE											
PAN, TILT, ZOOM CAMERA											
WIRELESS DETECTOR SENSOR											
WIRELESS ACCESS POINT											

RAILROAD SYMBOLS

	EXISTING	PROPOSED
RAILROAD CONTROL CABINET		
RAILROAD CANTILEVER MAST ARM		
FLASHING SIGNAL		
CROSSING GATE		
CROSSBUCK		

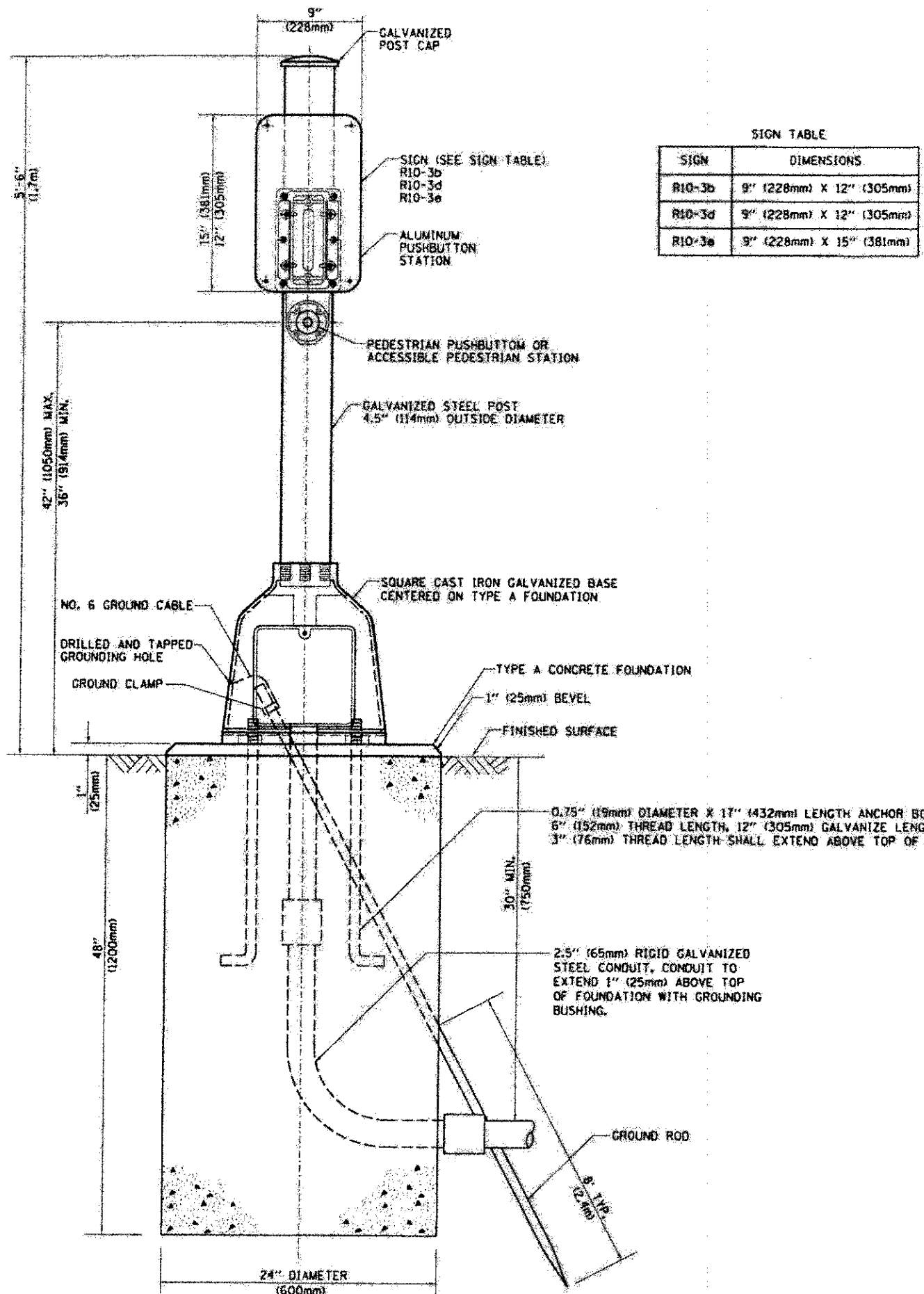

SIGN TABLE

SIGN	DIMENSIONS
R10-3b	9" (228mm) X 12" (305mm)
R10-3d	9" (228mm) X 12" (305mm)
R10-3e	9" (228mm) X 15" (381mm)

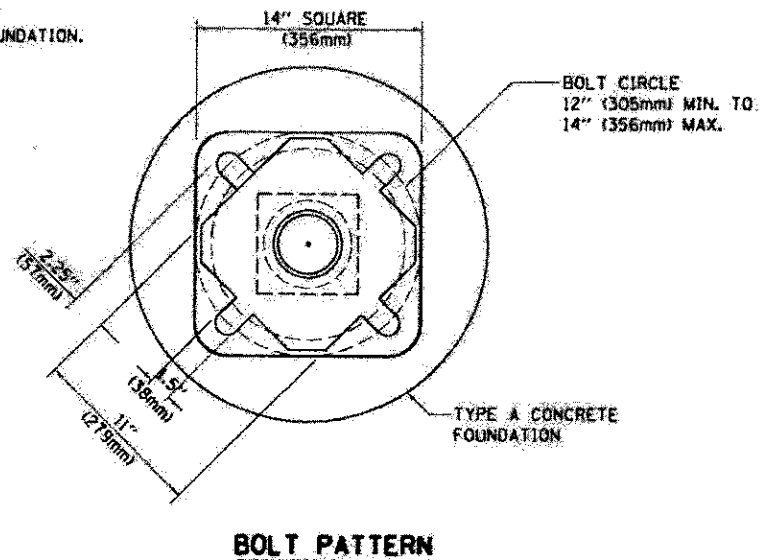

FILE NAME: 01\p\... 11/13/2012	USER NAME: d... 11/13/2012	DESIGNED: DAG DRAWN: GND CHECKED: DAG DATE: 10/1/2012	REVISED: - REVISED: - REVISED: - REVISED: -	STATE OF ILLINOIS DEPARTMENT OF TRANSPORTATION	DISTRICT 1 PEDESTRIAN PUSH BUTTON POST, TYPE A	F.A. RTE.: 1100 SECTION: 11-00087-00-EP COUNTY: COOK TOTAL SHEETS: 164 SHEET NO.: 96	CONTRACT NO.: 63770
SCALE: NONE				SHEET NO. 1 OF 1 SHEETS STA. TO STA.		FED. ROAD DIST. NO. 1 ILLINOIS FED. AID PROJECT CEN 9003 (757)	

BARRINGTON POINTE



PLAN	SURVEYED	DATE
	PLOTTED	
	ALIGNED	
	CHECKED	
	NO. _____	

PROFILE	SURVEYED	DATE
	PLOTTED	
	GRADES CHECKED	
	STRUCTURE NOTATIONS CHKD	
	NO. _____	

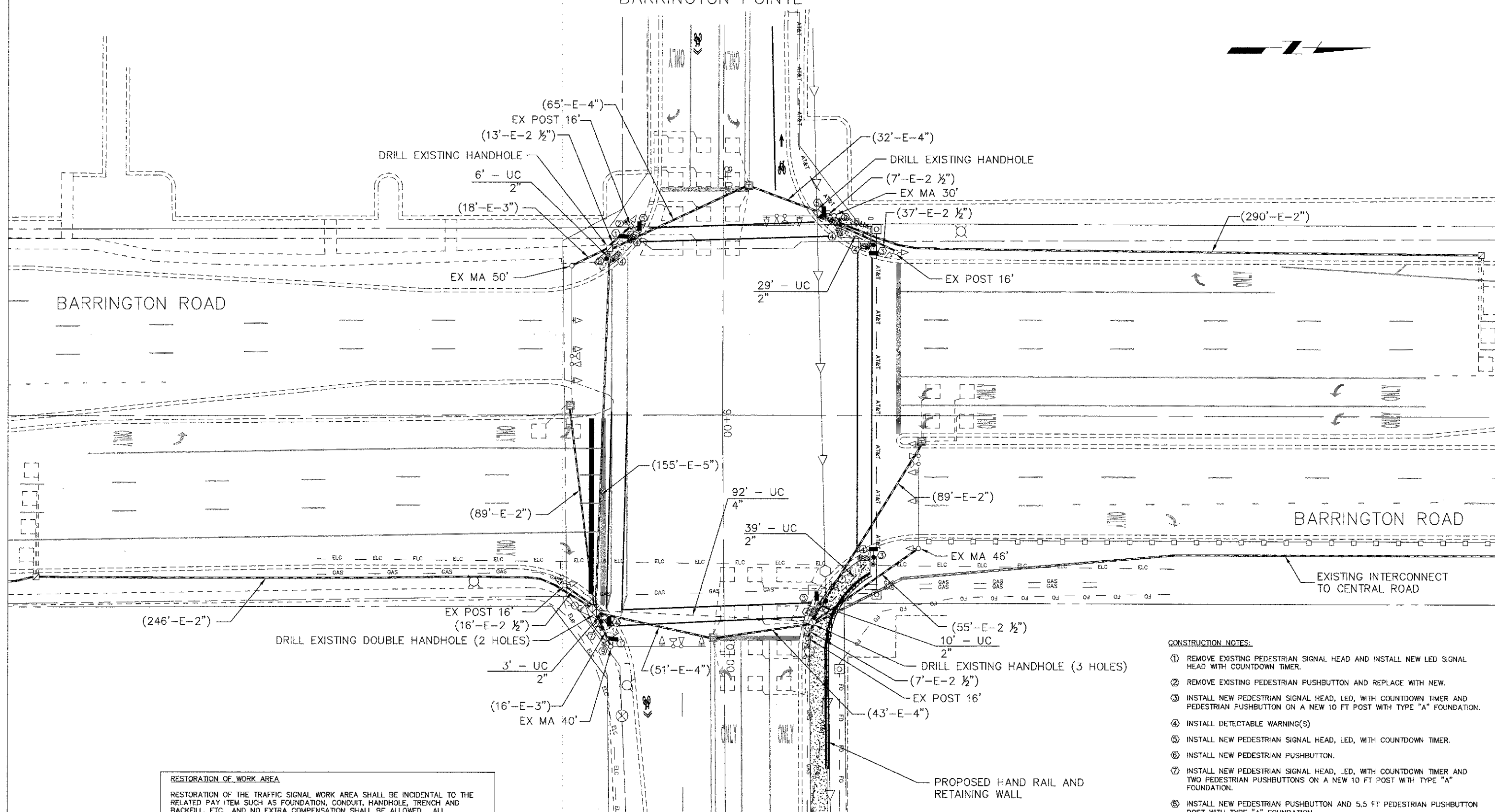

RESTORATION OF WORK AREA
 RESTORATION OF THE TRAFFIC SIGNAL WORK AREA SHALL BE INCIDENTAL TO THE RELATED PAY ITEM SUCH AS FOUNDATION, CONDUIT, HANDHOLE, TRENCH AND BACKFILL, ETC., AND NO EXTRA COMPENSATION SHALL BE ALLOWED. ALL ROADWAYS SURFACES SUCH AS SHOULDERS, MEDIANS, SIDEWALKS, PAVEMENT, ETC. SHALL BE REPLACED IN KIND. ALL DAMAGE TO MOWED LAWNS SHALL BE REPLACED WITH AN APPROVED SOD AND ALL DAMAGE TO UNMOWED LAWNS SHALL BE SEEDED IN ACCORDANCE WITH STANDARD SPECIFICATIONS 252 AND 250 RESPECTIVELY.

- CONSTRUCTION NOTES:**
- ① REMOVE EXISTING PEDESTRIAN SIGNAL HEAD AND INSTALL NEW LED SIGNAL HEAD WITH COUNTDOWN TIMER.
 - ② REMOVE EXISTING PEDESTRIAN PUSHBUTTON AND REPLACE WITH NEW.
 - ③ INSTALL NEW PEDESTRIAN SIGNAL HEAD, LED, WITH COUNTDOWN TIMER AND PEDESTRIAN PUSHBUTTON ON A NEW 10 FT POST WITH TYPE "A" FOUNDATION.
 - ④ INSTALL DETECTABLE WARNING(S)
 - ⑤ INSTALL NEW PEDESTRIAN SIGNAL HEAD, LED, WITH COUNTDOWN TIMER.
 - ⑥ INSTALL NEW PEDESTRIAN PUSHBUTTON.
 - ⑦ INSTALL NEW PEDESTRIAN SIGNAL HEAD, LED, WITH COUNTDOWN TIMER AND TWO PEDESTRIAN PUSHBUTTONS ON A NEW 10 FT POST WITH TYPE "A" FOUNDATION.
 - ⑧ INSTALL NEW PEDESTRIAN PUSHBUTTON AND 5.5 FT PEDESTRIAN PUSHBUTTON POST WITH TYPE "A" FOUNDATION.
 - ⑨ REMOVE EXISTING PEDESTRIAN PUSHBUTTON.

THE FOLLOWING ITEMS SHALL BE REMOVED BY THE CONTRACTOR AND SHALL BE DISPOSED OF BY THEM OUTSIDE THE RIGHT-OF-WAY AT THEIR EXPENSE. THE SALVAGE VALUE OF THE REMOVED ITEMS SHALL BE REFLECTED IN THE CONTRACT UNIT BID PRICE:

2 EACH PEDESTRIAN SIGNAL HEAD, 1-FACE
 2 EACH PEDESTRIAN PUSH BUTTON

FILE NAME =	DESIGNED -	REVISED -
Hassell Plan-Profile.dwg	DRAWN -	REVISED -
	CHECKED -	REVISED -
	DATE -	REVISED -

STATE OF ILLINOIS
DEPARTMENT OF TRANSPORTATION

Hassell Road STP Project
 Traffic Signal Modification Plan - Barrington Road & Hassell Road
 SCALE: 1" = 20' SHEET NO. 1 OF 2 SHEETS STA. TO STA.

F.A.U. RTE.	SECTION	COUNTY	TOTAL SHEETS	SHEET NO.
1100	11-00087-00-FP	Cook	164	97
CONTRACT NO. 63770				
ILLINOIS FED. AID PROJECT CMM 9003(757)				

SCHEDULE OF QUANTITIES

PAY ITEM #	DESCRIPTION	UNIT	QTY
20200100	EARTH EXCAVATION	CU YD	20
35101600	AGGREGATE BASE COURSE, TYPE B 4"	SQ YD	72
42400200	PORTLAND CEMENT CONCRETE SIDEWALK 5 INCH	SQ FT	650
42400800	DETECTABLE WARNINGS	SQ FT	80
44000500	COMBINATION CURB AND GUTTER REMOVAL	FOOT	150
44000600	SIDEWALK REMOVAL	SQ FT	300
50901760	PIPE HANDRAIL	FOOT	90
60905100	COMBINATION CONCRETE CURB AND GUTTER, TYPE B-6.24 (ABUTTING EXISTING PAVEMENT)	FOOT	150
81028200	UNDERGROUND CONDUIT, GALVANIZED STEEL, 2" DIA	FOOT	87
81028240	UNDERGROUND CONDUIT, GALVANIZED STEEL, 4" DIA	FOOT	92
85000300	MAINTENANCE OF EXISTING TRAFFIC SIGNAL INSTALLATION	L SUM	1
87301215	ELECTRIC CABLE IN CONDUIT, SIGNAL NO. 14 2C	FOOT	1396
87301225	ELECTRIC CABLE IN CONDUIT, SIGNAL NO. 14 3C	FOOT	1465
87301900	ELECTRIC CABLE IN CONDUIT, EQUIPMENT GROUNDING CONDUCTOR, NO. 6 1C	FOOT	120
87502440	TRAFFIC SIGNAL POST, GALVANIZED STEEL 10 FT.	EACH	4
87800100	CONCRETE FOUNDATION, TYPE A	FOOT	20
87900200	DRILL EXISTING HANDHOLE	EACH	7
88102717	PEDESTRIAN SIGNAL HEAD, LED, 1-FACE, BRACKET MOUNTED WITH COUNTDOWN TIMER	EACH	6
88102747	PEDESTRIAN SIGNAL HEAD, LED, 2-FACE, BRACKET MOUNTED WITH COUNTDOWN TIMER	EACH	1
88800100	PEDESTRIAN PUSH-BUTTON	EACH	8
89502375	REMOVE EXISTING TRAFFIC SIGNAL EQUIPMENT	EACH	1
XB760055	PEDESTRIAN PUSH-BUTTON POST, TYPE A	EACH	1
Z0064980	SEGMENTAL BLOCK RETAINING WALL	SQ FT	180

PLAN	SURVEYED	DATE
	ALIGNED	DATE
	NOTED	DATE
	CHECKED	DATE
	BY	NAME
	NO.	DATE

PROFILE	SURVEYED	DATE
	ALIGNED	DATE
	NOTED	DATE
	CHECKED	DATE
	BY	NAME
	NO.	DATE

I.D.O.T. TRAFFIC SIGNAL INSTALLATION ELECTRICAL SERVICE REQUIREMENTS					
TYPE	NO. LAMPS	WATTAGE		% OPERATION	TOTAL WATTAGE
		INCAND.	LED		
SIGNAL (RED)	14		17	0.50	119.0
(YELLOW)	14		25	0.25	87.5
(GREEN)	14		15	0.25	52.5
ARROW	32		12	0.10	38.4
PED SIGNAL	8		25	1.00	200.0
CONTROLLER	1		100	1.00	100.0
TOTAL =					597.4

ENERGY COSTS TO: VILLAGE OF HOFFMAN ESTATES
1900 HASSELL ROAD
HOFFMAN ESTATES, IL 60169

ENERGY SUPPLY CONTACT: JUDY SCHOMER
PHONE: (847) 870-2063
COMPANY: COMMONWEALTH EDISON

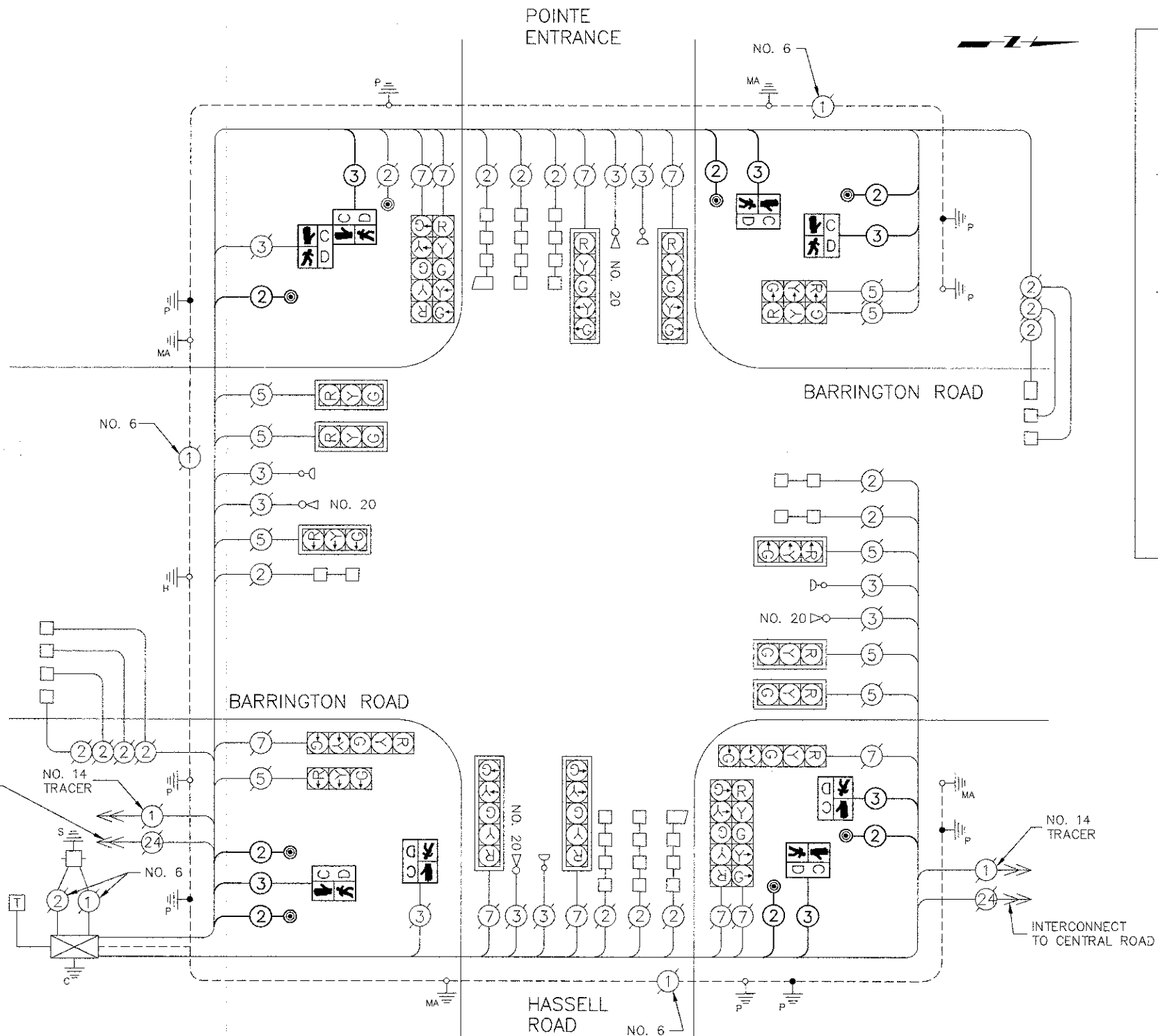

CABLE PLAN
NOT TO SCALE

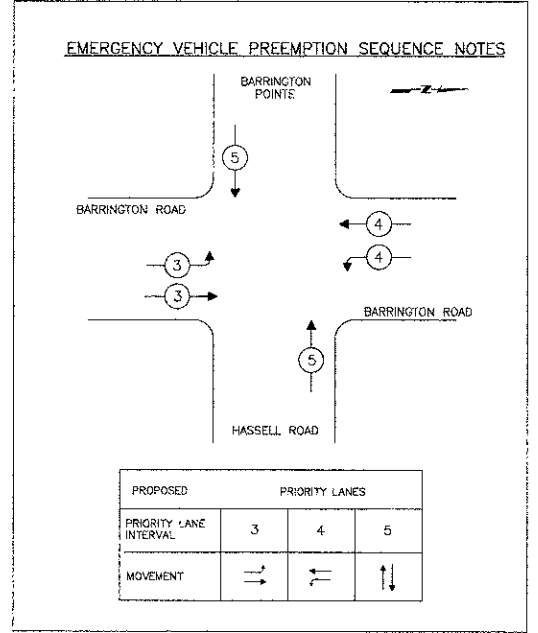
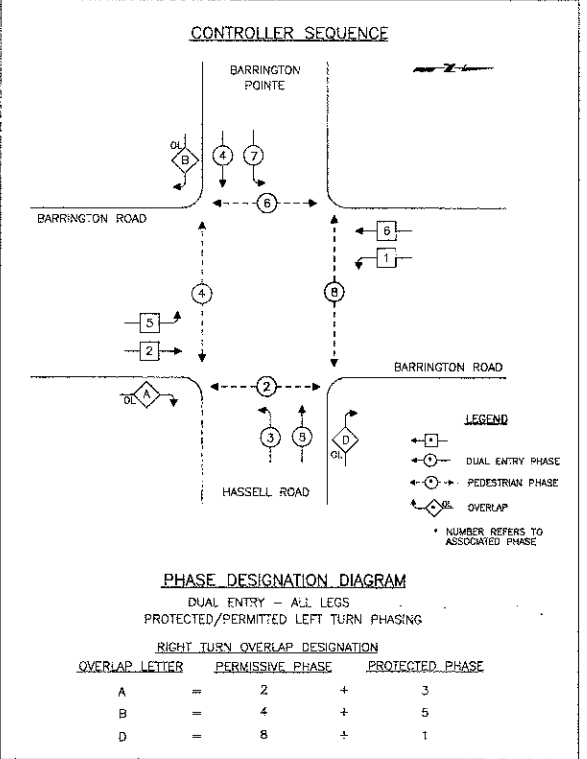

- CONSTRUCTION NOTES:**
- CONTRACTOR TO INSTALL NEW PEDESTRIAN HEAD, LED, 1-FACE OR 2-FACE WITH COUNTDOWN TIMER AND NEW PEDESTRIAN PUSH-BUTTON, LED (LATCHING TYPE).
 - CONTRACTOR TO INSTALL NEW 10 FT POST WITH TYPE "A" FOUNDATION AS SHOWN ON THE PLANS.

Benchmark: Chiseled square at the northwest corner of headwall, Elevation 787.83 feet. Datum = NGVD29

Existing Structure: SN 016-6328 built IN 1970 as a triple 10-ft x 5-ft reinforced concrete box culvert, approximate out-to-out width of 33'-4", and approximately 83'-0" in length.

Traffic: Traffic will be maintained during construction utilizing staged construction.

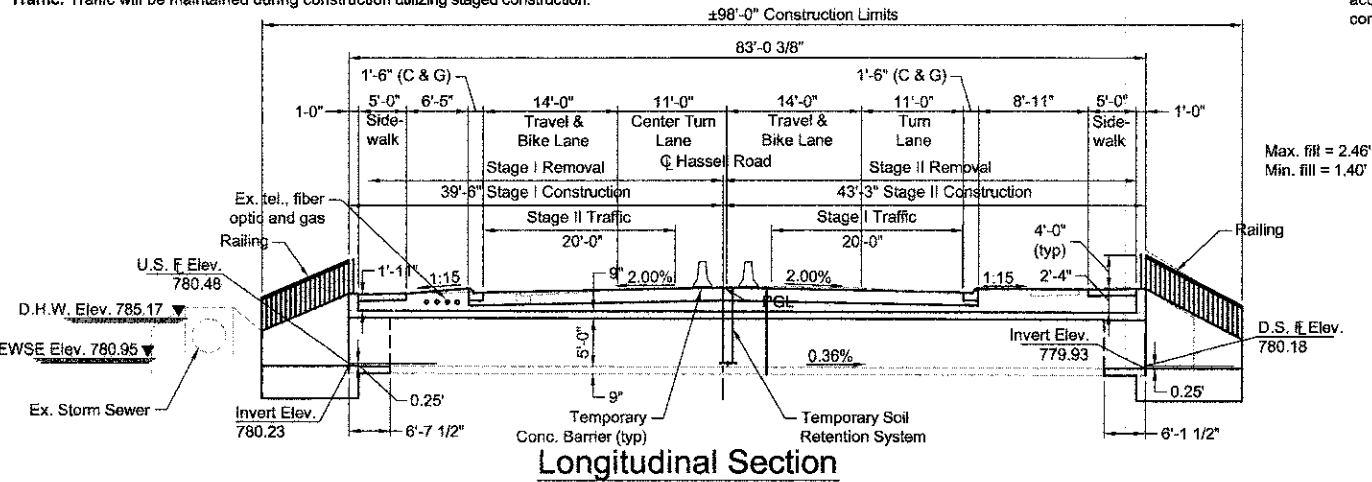

Longitudinal Section

Note: Dimensions at right angles to Centerline of Roadway unless otherwise noted.

General Notes

1. Diversion of stream flow during the removal of the existing culvert and the construction of the proposed culvert and all required erosion control measures shall be considered as included in concrete box culverts and no additional compensation will be allowed.
2. Existing culvert cells shall be cleared of debris with the debris being disposed of in accordance with Article 202.03. This shall be included in concrete removal and no additional compensation will be allowed.

Sheet No.

- CA1 General Plan & Longitudinal Section
- CA2 Stage Construction Details
- CA3 Concrete Removal Details
- CA4 North End Section
- CA5 South End Section
- CA6 Top Slab Details
- CA7 Decorative Steel Railing Details
- CA8 Bar Splicer Assembly
- CA9 Soil Boring Logs

Index of Sheets

Description

Total Bill of Material

ITEM	UNIT	QUANTITY
CONCRETE REMOVAL	CU YD	114.8
BRIDGE RAIL REMOVAL	FOOT	108
REINFORCEMENT BARS	POUND	7,310
REINFORCEMENT BARS, EPOXY COATED	POUND	23,910
NAME PLATES	EACH	1
EXPANSION BOLTS 3/4 INCH	EACH	82
CONCRETE BOX CULVERTS	CU YD	123
CONCRETE COLLAR	CU YD	1
STORM SEWER REMOVAL 24"	FOOT	4
STORM SEWERS, CLASS A, TYPE 2 24"	FOOT	6
DECORATIVE STEEL RAILING	FOOT	105
FORM LINER TEXTURED SURFACE, SPECIAL	SQ FT	273
TEMPORARY SOIL RETENTION SYSTEM	SQ FT	1,277

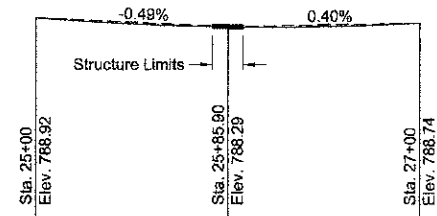

Profile Grade

(along C roadway)

Waterway Information Table

Flood		Frequency Year	Discharge (cfs)	Waterway Opening (sq. ft.) Existing	Waterway Opening (sq. ft.) Proposed	Natural H.W.E.	Created Head (ft.) Existing	Created Head (ft.) Proposed	Headwater Elev. Existing	Headwater Elev. Proposed
Design		10	215.00	126.0	126.0	784.43	0.00	0.00	784.43	784.43
Base		30	305.00	148.2	148.2	785.17	0.00	0.00	785.17	785.17
Max Calc.		50	340.00	150.0	150.0	785.51	0.04	0.04	785.55	785.55
		100	400.00	150.0	150.0	785.99	0.08	0.08	786.07	786.07
		500	555.00	150.0	150.0	786.61	0.21	0.21	786.82	786.82

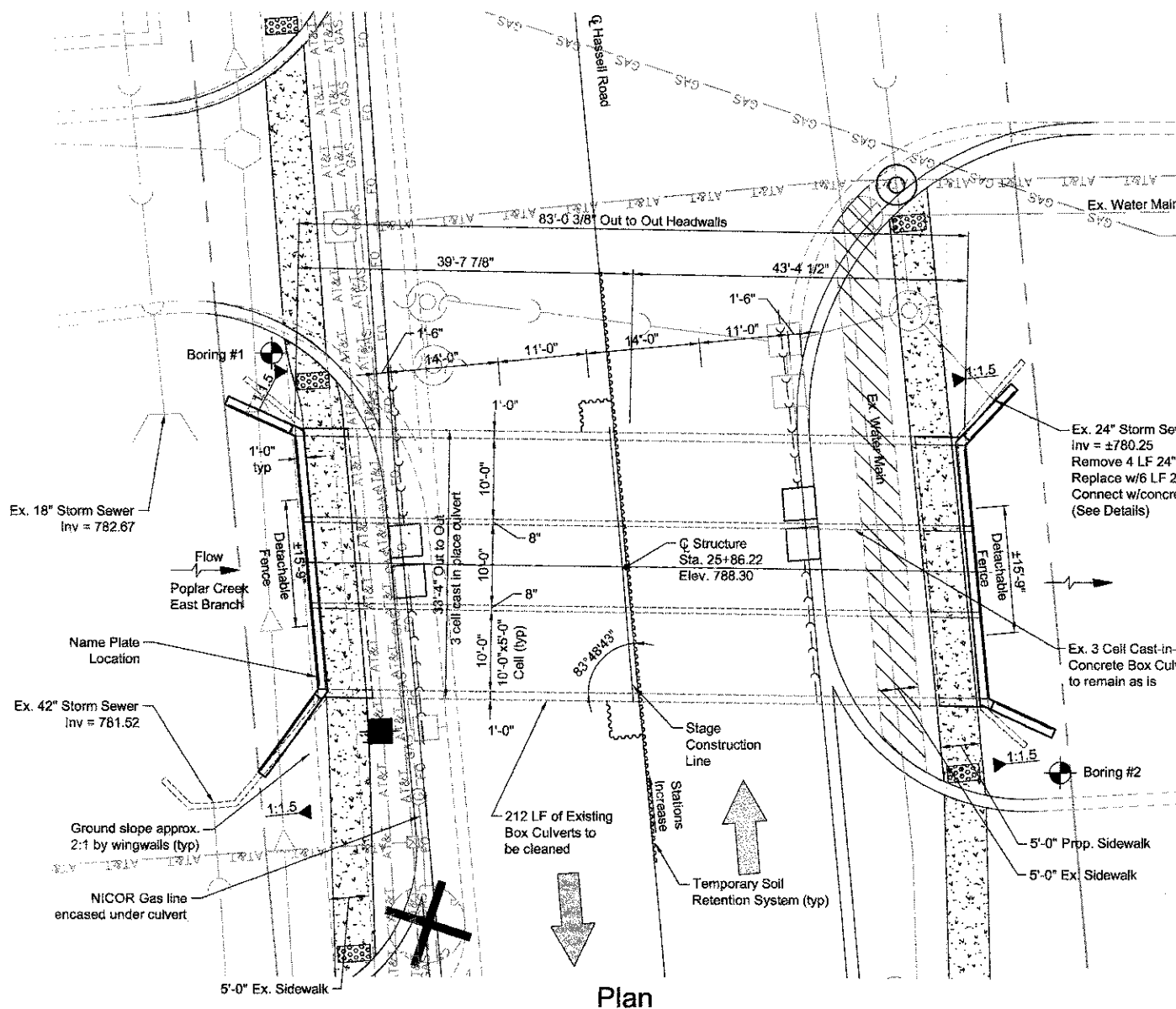

Plan

Note: Dimensions at right angles to Centerline of Roadway unless otherwise depicted.

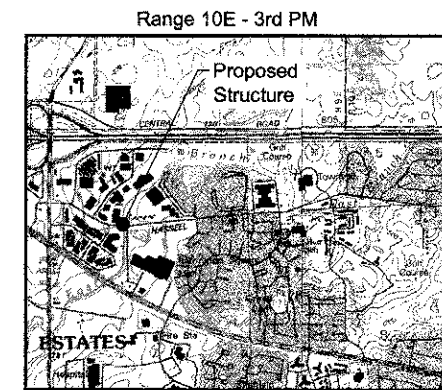

Location Sketch

Loading HS20-44
Allow 50#/sq-ft for future wearing surface.

Design Specifications
2002 AASHTO Standard Specifications for Highway Bridges

Design Stresses
Field Units (New Construction)
f_c = 3,500 psi
f_y = 60,000 psi (reinforcement)

CIVILTECH ENGINEERS, INC.
GREGORY J. HATLESTAD, S.E.



EXP. 11/30/2014
DATE 12/14/2012

I certify that to the best knowledge, information and belief, this box culvert design is structurally adequate for the design loading shown on the shown plans. The design is an economical one for the style of the structure and complies with the requirements of the 2002 AASHTO Standard Specifications.

Station 25+86
Built 201 by
Hoffman Estates
Loading HS20
Structure No. 016-6328

Name Plate
See Std. 515001

General Plan & Longitudinal Section
Hassell Road over
Poplar Creek East Branch
F.A.U.Rt. 1100
Section 11-00087-00-FP
Cook County
Station 25+86.22
Structure No. 016-6328
(Existing)

STATE OF ILLINOIS
DEPARTMENT OF TRANSPORTATION

Hassell Road STP Project
Structure No. 016-6328

F.A.U. RTE.	SECTION	COUNTY	TOTAL SHEETS	SHEET NO.
1100	11-00087-00-FP	Cook	164	99

SCALE: 1" = 10' SHEET NO. CA1 OF CA9 SHEETS STA. TO STA.

CONTRACT NO. 63770 ILLINOIS FED. AID PROJECT CMM 9003(757)

PLAN	DESIGNED	DATE
	DRAWN	
	CHECKED	
	DATE	

PROFILE	DESIGNED	DATE
	DRAWN	
	CHECKED	
	DATE	

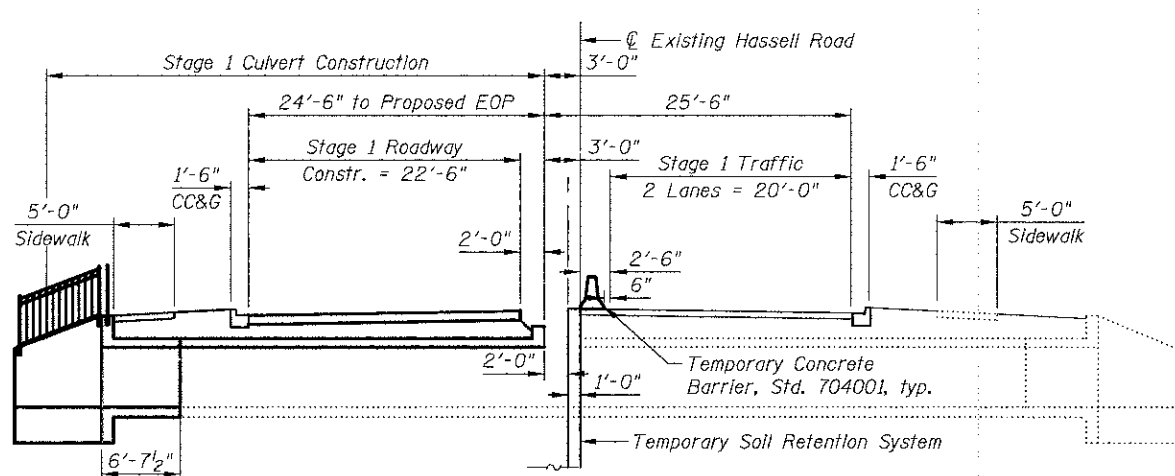

STAGE 1 CONSTRUCTION

Dimensions are taken at right angles to $\text{\textcircled{C}}$ roadway Looking East

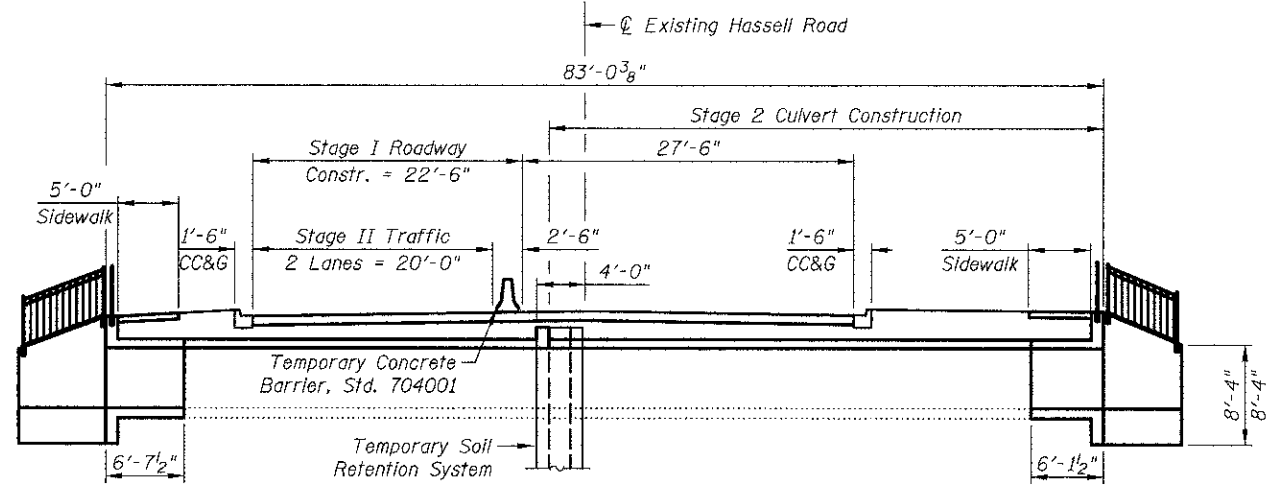

STAGE 2 CONSTRUCTION

Dimensions are taken at right angles to $\text{\textcircled{C}}$ roadway Looking East

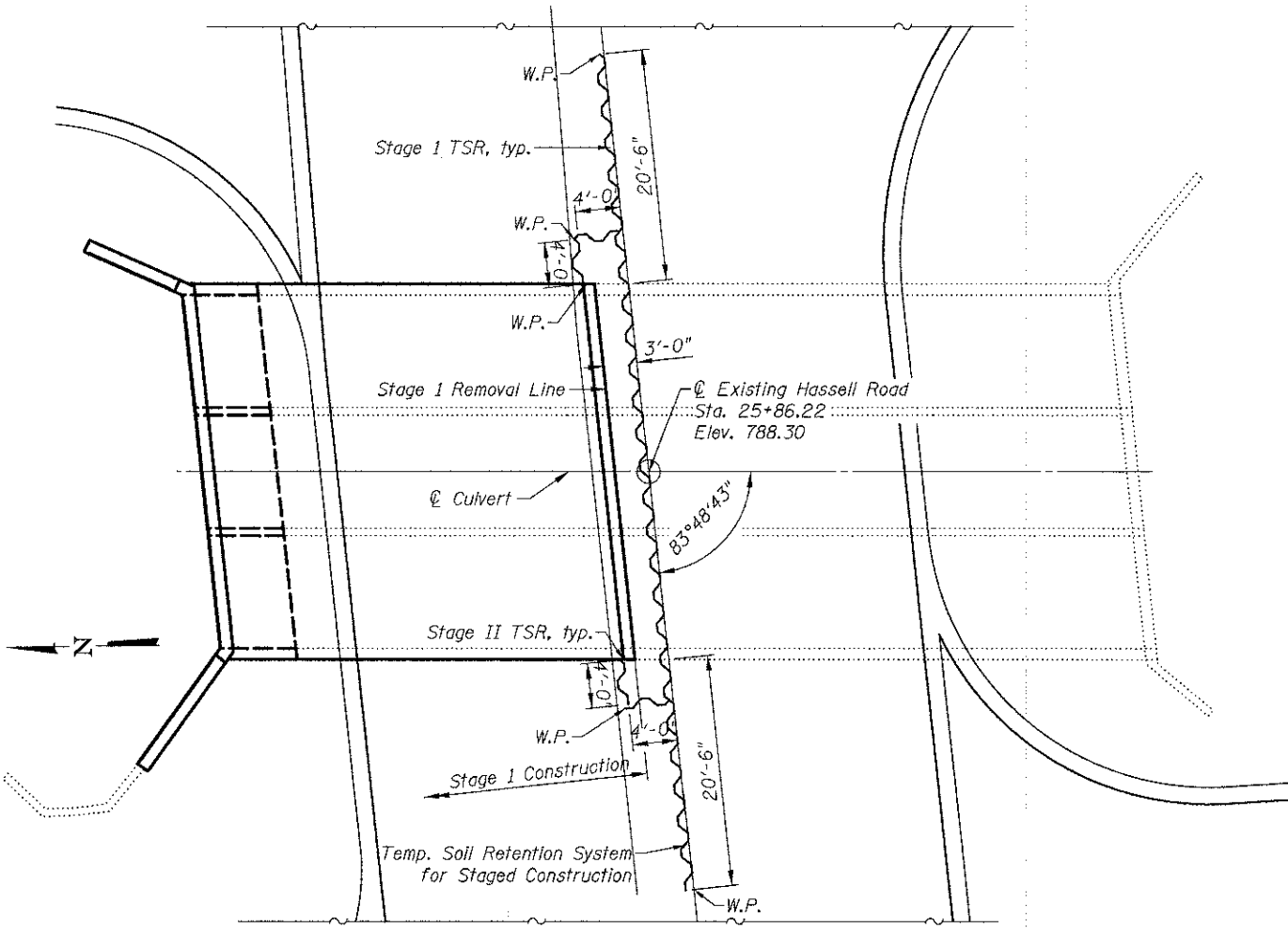

TEMPORARY SOIL RETENTION SYSTEM - PLAN

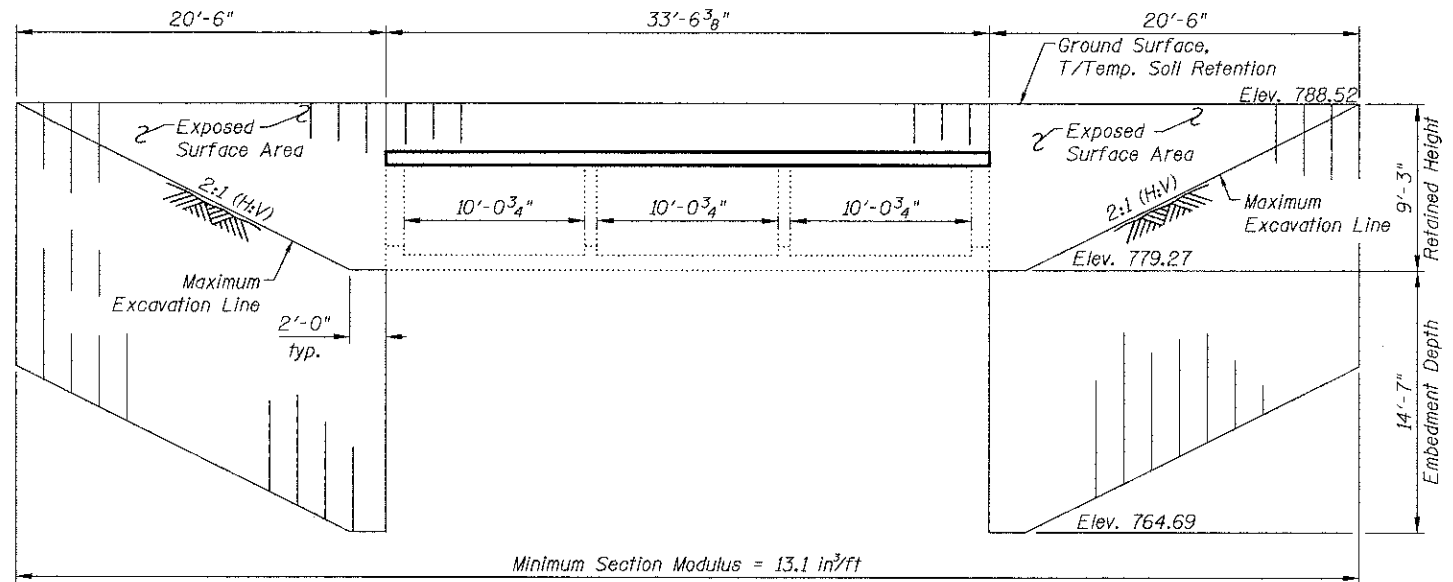

TEMPORARY SOIL RETENTION SYSTEM - ELEVATION

BILL OF MATERIAL

Item	Unit	Quantity
Temporary Soil Retention System	Sq. Ft.	1,277

TSR = Temporary Soil Retention
W.P. = Work Point

J:\244\oad\016-6328\02_Stage Construction Details.r2.dgn 12/12/2012 10:31:04 AM

CIVILTECH
450 E Devon Ave, Suite 300
Itasca, Illinois 60143
Tel: 630.773.3900 Fax: 630.773.3975
www.civiltechinc.com

DRAWN - K. BOCHNOWSKI	REVISED -
DESIGNED - M. LANGE	REVISED -
CHECKED - G. HATLESTAD	REVISED -
DATE - DECEMBER 17, 2012	REVISED -

**STATE OF ILLINOIS
DEPARTMENT OF TRANSPORTATION**

**STAGE CONSTRUCTION DETAILS
HASSELL ROAD OVER POPLAR CREEK
STRUCTURE NO. 016-6328**

F.A.U. RTE.	SECTION	COUNTY	TOTAL SHEETS	SHEET NO.
1100	11-00087-00-FP	COOK	164	100
CONTRACT NO. 63770				
ILLINOIS FED. AID PROJECT CNR 90031757				

SHEET NO. CA2 OF CA9 SHEETS

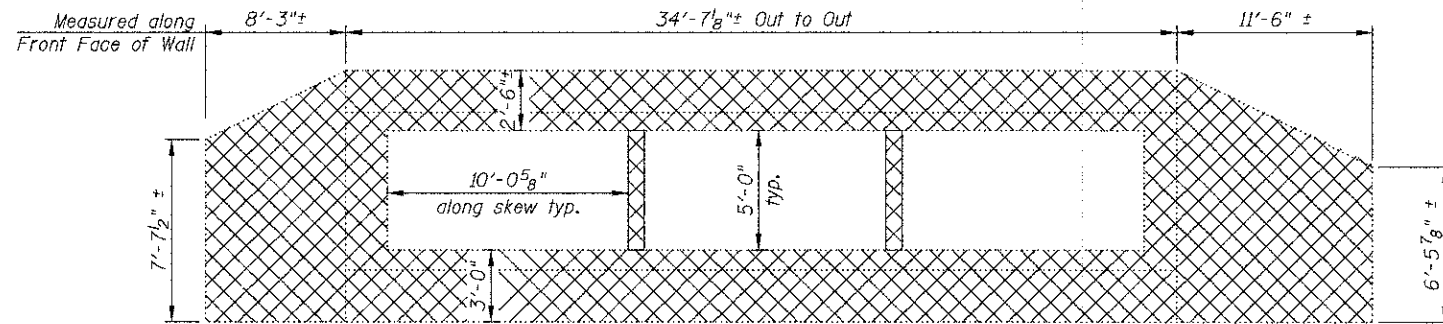

NORTH END SECTION

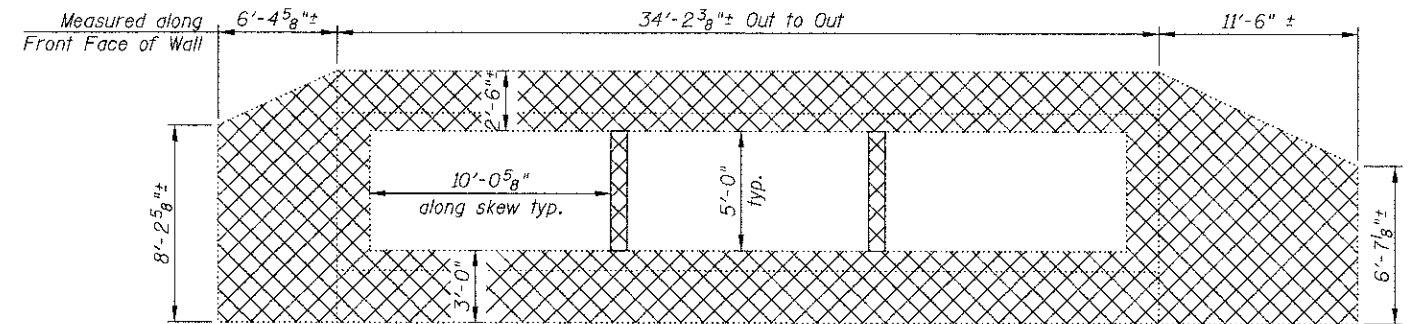

SOUTH END SECTION

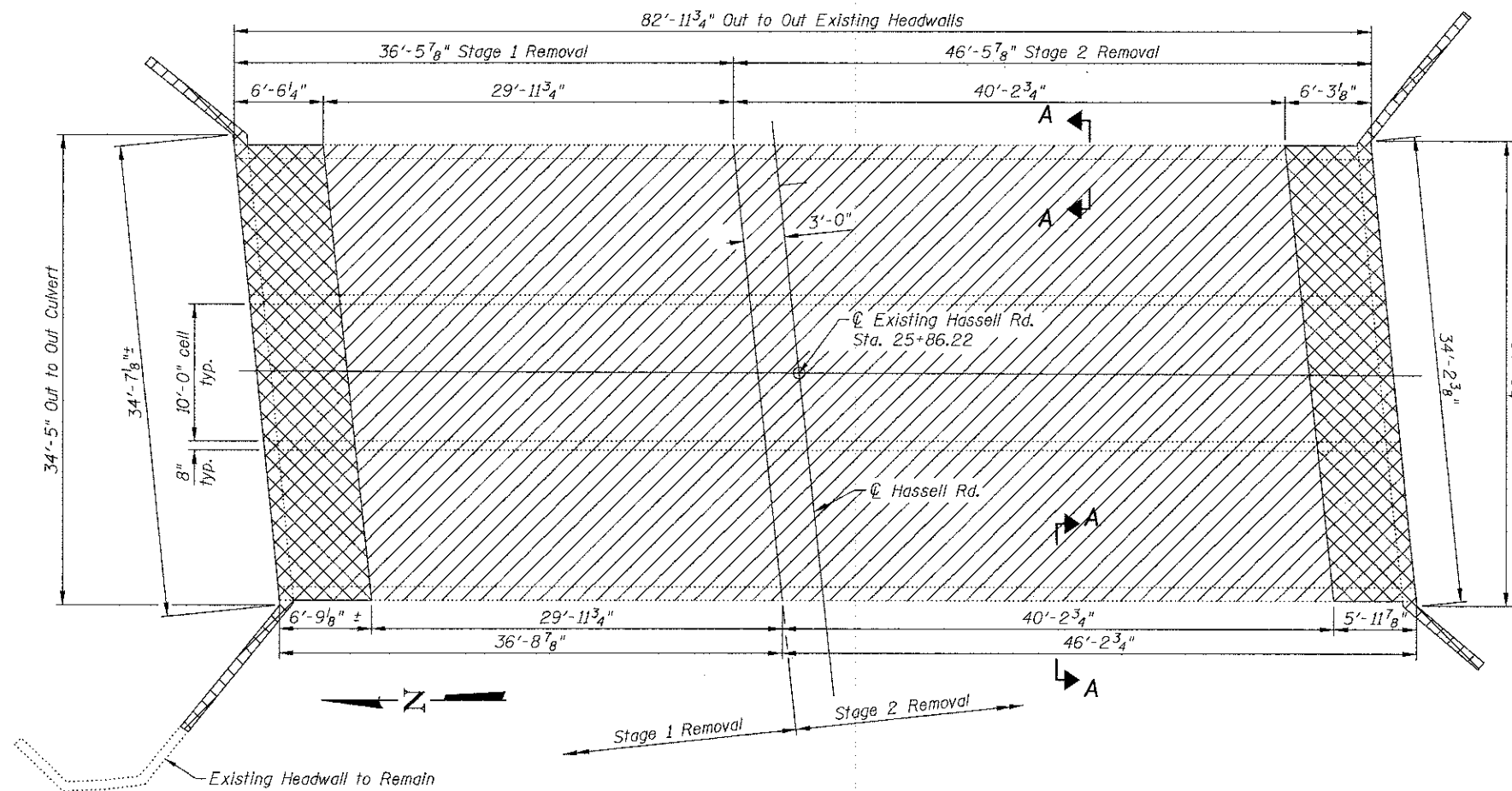

REMOVAL PLAN

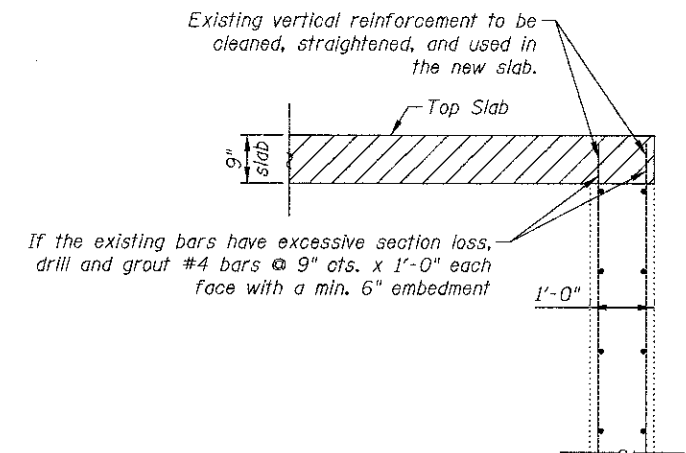

SECTION A-A

LEGEND

- Top Slab Removal
- Complete Removal of Structure

BILL OF MATERIAL

Item	Unit	Quantity
Concrete Removal	Cu. Yd.	114.8

12/12/2012 11:31:05 AM J:\244\wood\016-6328\03-Conc RemovalDetails.dgn

CIVILTECH
 450 E Devon Ave, Suite 300
 Itasca, Illinois 60143
 Tel: 630.773.3900 Fax: 630.773.3975
 www.civiltechinc.com

DRAWN - K. BOCHNOWSKI	REVISED -
DESIGNED - M. LANGE	REVISED -
CHECKED - G. HATLESTAD	REVISED -
DATE - DECEMBER 17, 2012	REVISED -

STATE OF ILLINOIS
DEPARTMENT OF TRANSPORTATION

CONCRETE REMOVAL DETAILS
HASSELL ROAD OVER POPLAR CREEK
STRUCTURE NO. 016-6328
 SHEET NO. CA3 OF CA9 SHEETS

F.A.U. RTE.	SECTION	COUNTY	TOTAL SHEETS	SHEET NO.
1100	11-00087-00-FP	COOK	164	101
CONTRACT NO. 63770				
ILLINOIS FED. AID PROJECT CMM 9003(757)				

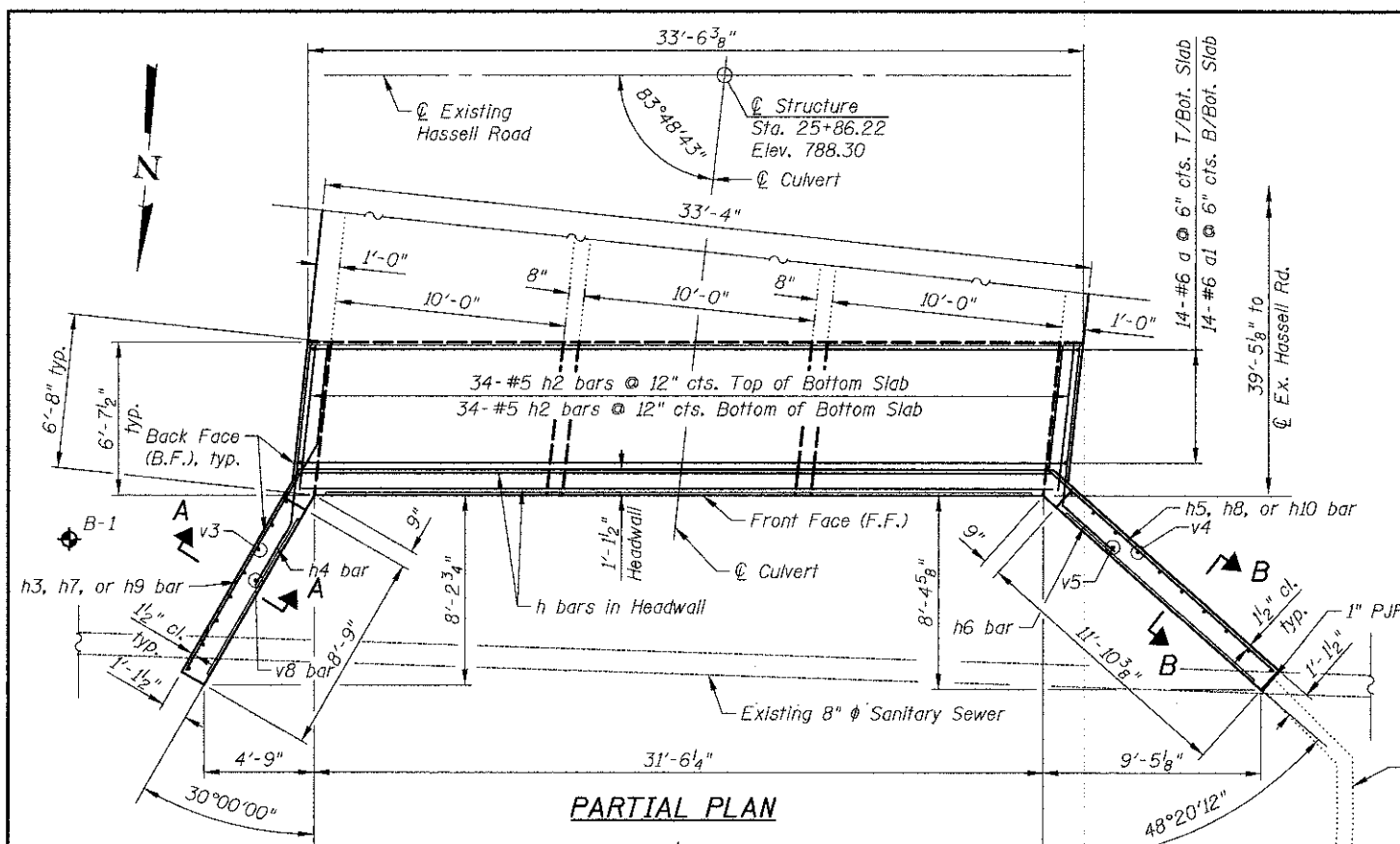

PARTIAL PLAN

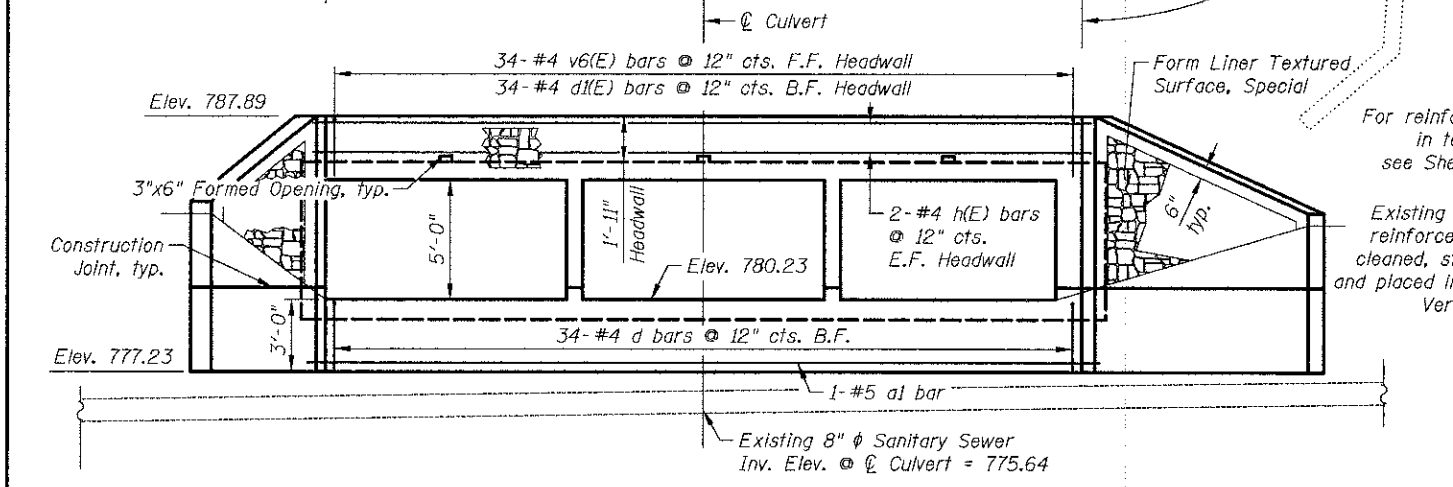

END VIEW - ELEVATION

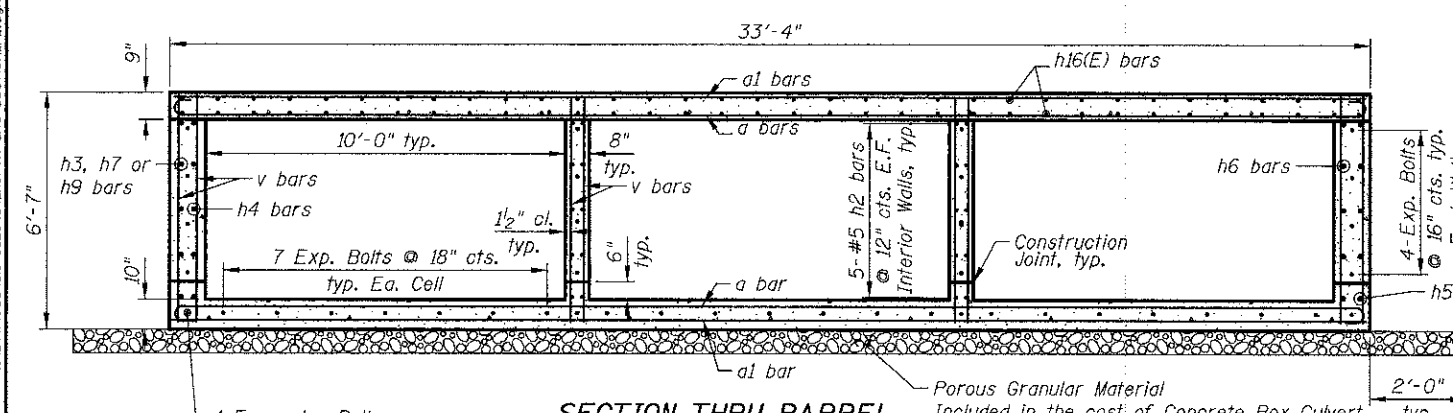

SECTION THRU BARREL

Expansion Bolts shall be 3/4 inch diameter hooked bolts. Hooked bolts shall extend a minimum of 9 inches into new concrete.

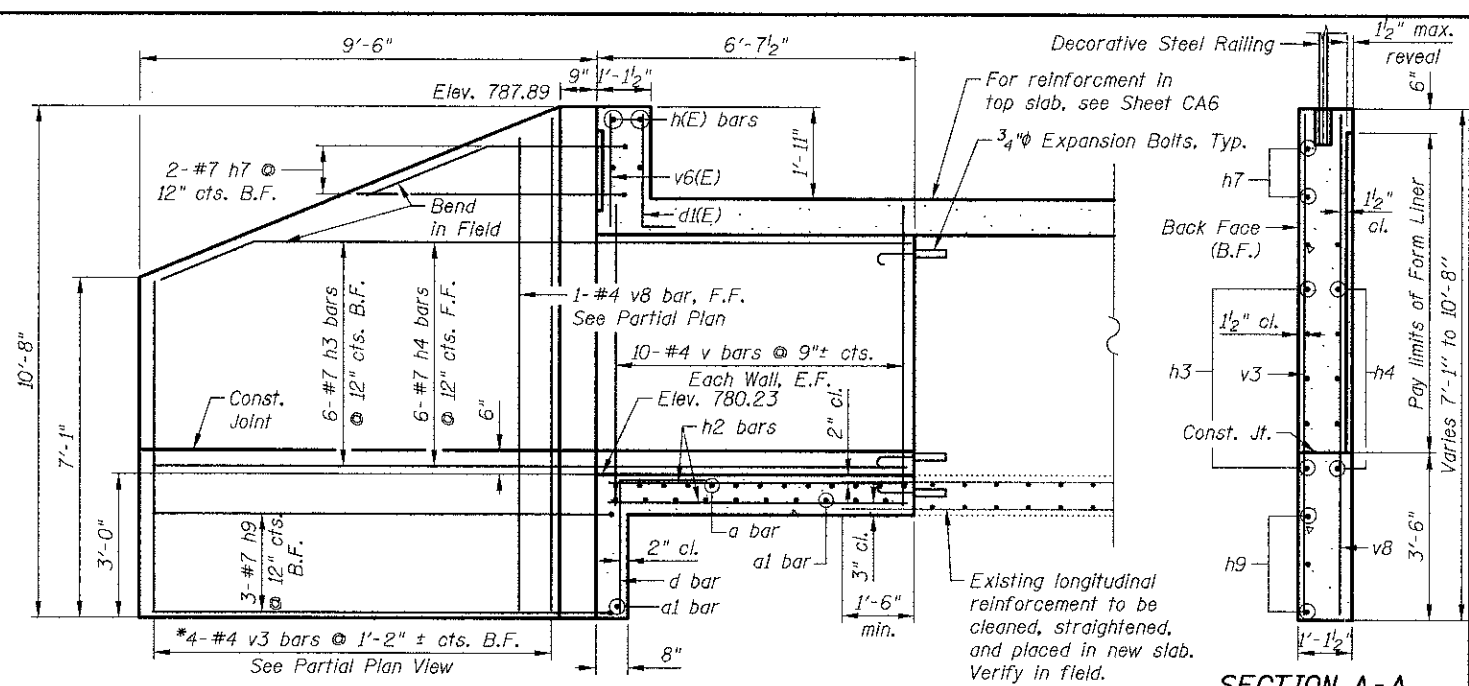

NORTHEAST WINGWALL

* See Field Cutting Diagram on sheet CA6

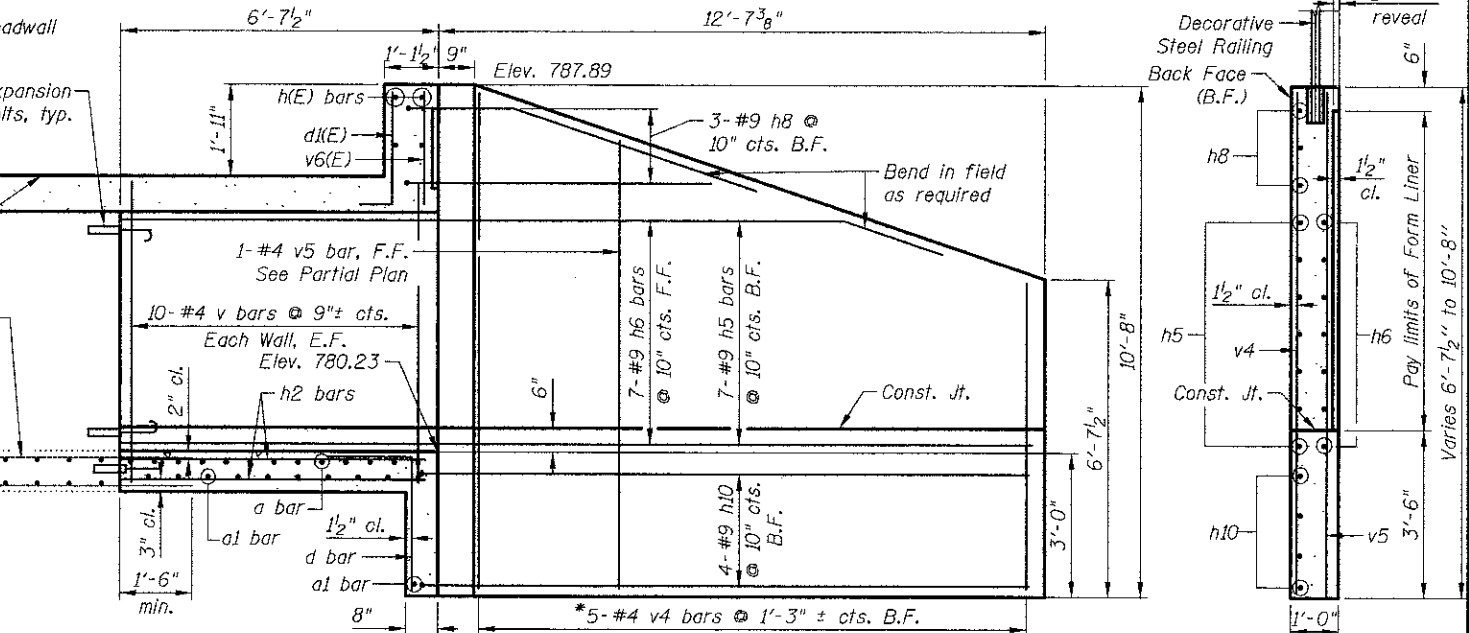

NORTHWEST WINGWALL

* See Field Cutting Diagram on sheet CA6

SECTION A-A

SECTION B-B

11/3/10 7 AM 12/10/2012 JA:244\ccad\016-6228\04_North_End_Section.rvt

CIVILTECH
 450 E Devon Ave, Suite 300
 Itasca, Illinois 60143
 Tel: 630.773.3900 Fax: 630.773.3975
 www.civiltechinc.com

DRAWN - K. BOCHNOWSKI	REVISED -
DESIGNED - M. LANGE	REVISED -
CHECKED - G. HATLESTAD	REVISED -
DATE - DECEMBER 17, 2012	REVISED -

STATE OF ILLINOIS
DEPARTMENT OF TRANSPORTATION

NORTH END SECTION
HASSELL ROAD OVER POPLAR CREEK
STRUCTURE NO. 016-6328
 SHEET NO. CA4 OF CA9 SHEETS

F.A.J. RTE.	SECTION	COUNTY	TOTAL SHEETS	SHEET NO.
1100	11-00087-00-FP	COOK	164	102
CONTRACT NO. 63770				

ILLINOIS FED. AID PROJECT CMM 9003(757)

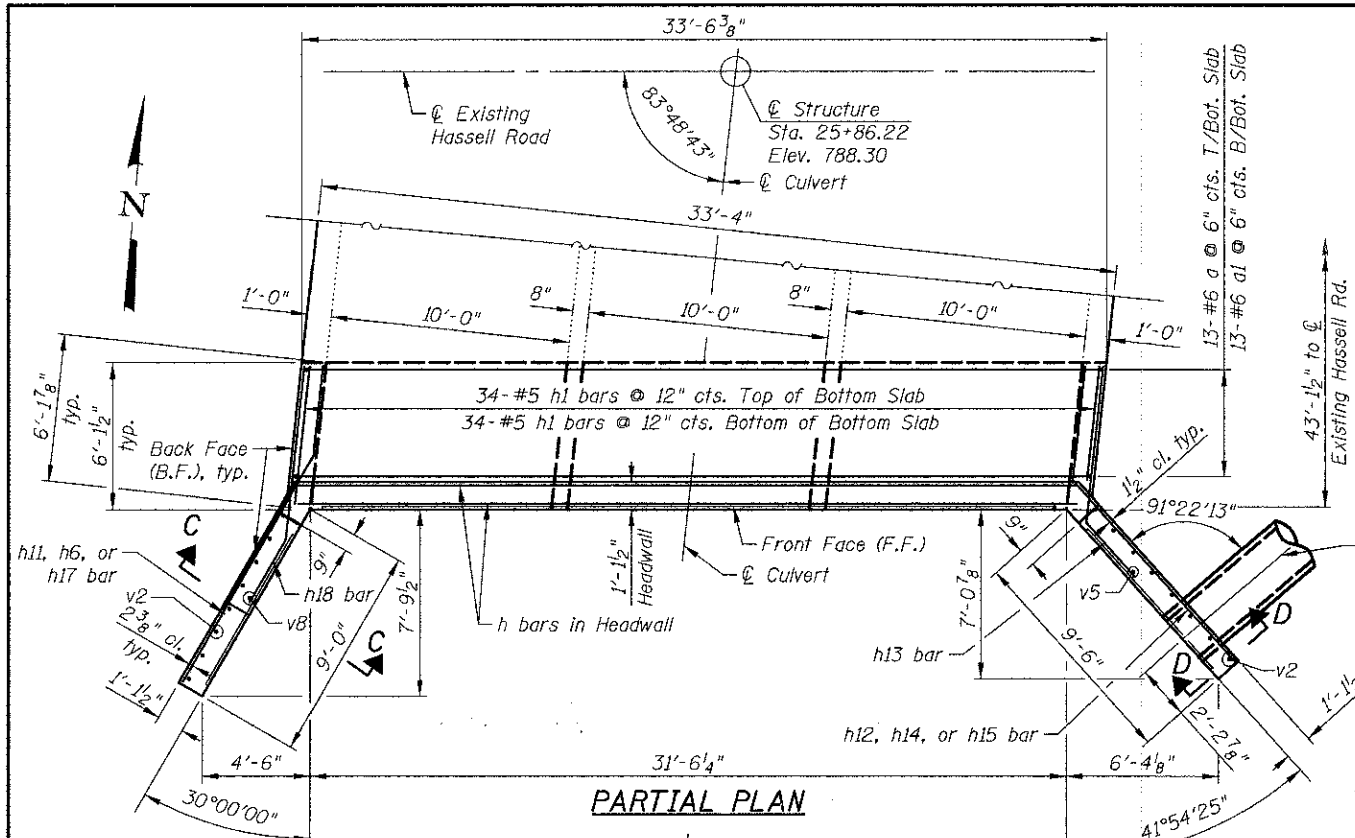

PARTIAL PLAN

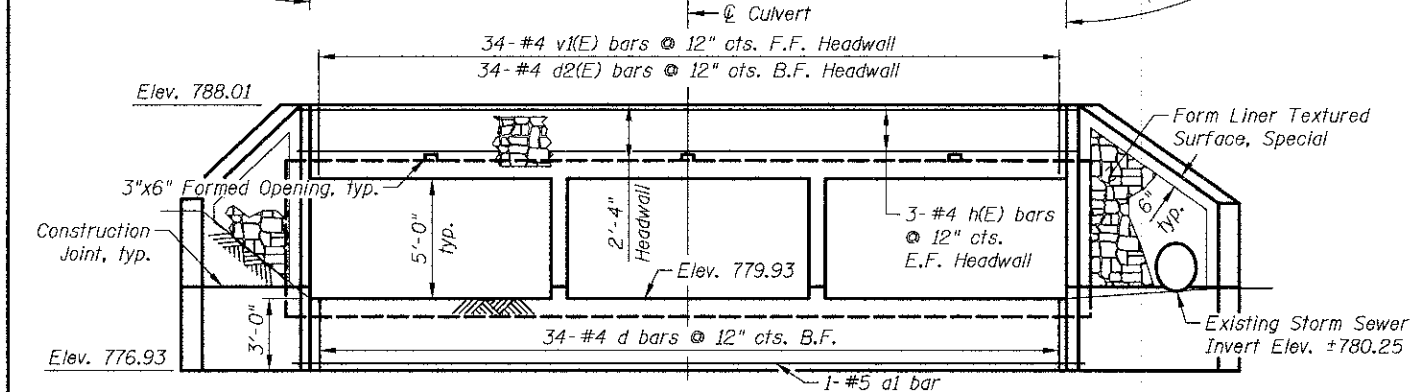

END VIEW - ELEVATION

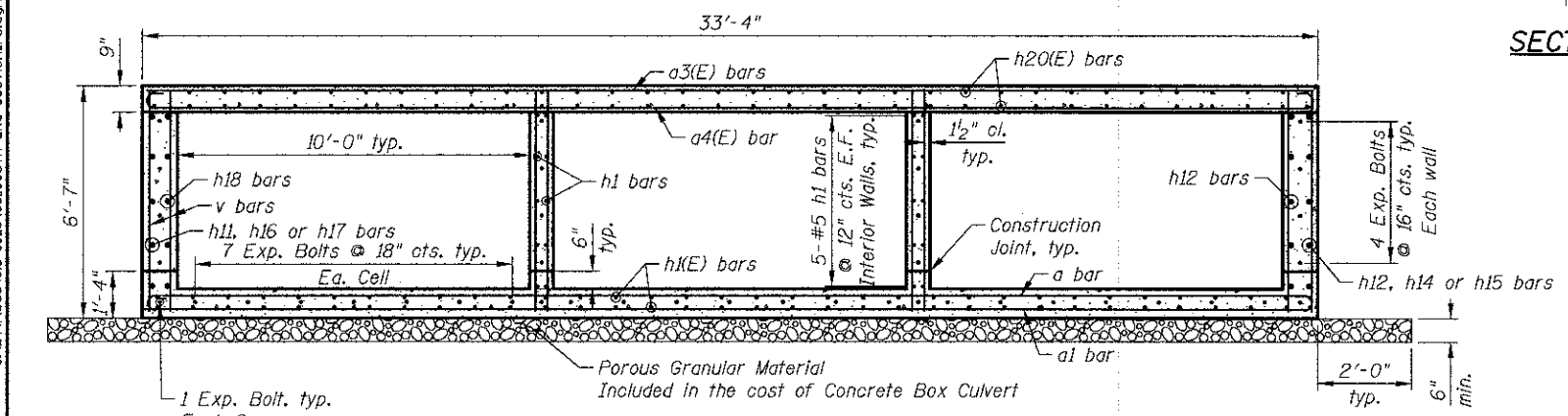

SECTION THRU BARREL

Expansion Bolts shall be 3/4" φ hooked bolts. Hooked bolts shall extend a minimum of 9" into new concrete.

450 E Devon Ave, Suite 300
Itasca, Illinois 60143
Tel. 630.773.3900 Fax: 630.773.3975
www.civiltechinc.com

DRAWN	- K. BOCHNOWSKI	REVISED	-
DESIGNED	- M. LANGE	REVISED	-
CHECKED	- G. HATLESTAD	REVISED	-
DATE	- DECEMBER 17, 2012	REVISED	-

STATE OF ILLINOIS
DEPARTMENT OF TRANSPORTATION

SOUTH END SECTION
HASSELL ROAD OVER POPLAR CREEK
STRUCTURE NO. 016-6328

F.A.U. RTE.	SECTION	COUNTY	TOTAL SHEETS	SHEET NO.
1100	11-00087-00-FP	COOK	164	103
CONTRACT NO. 63770				

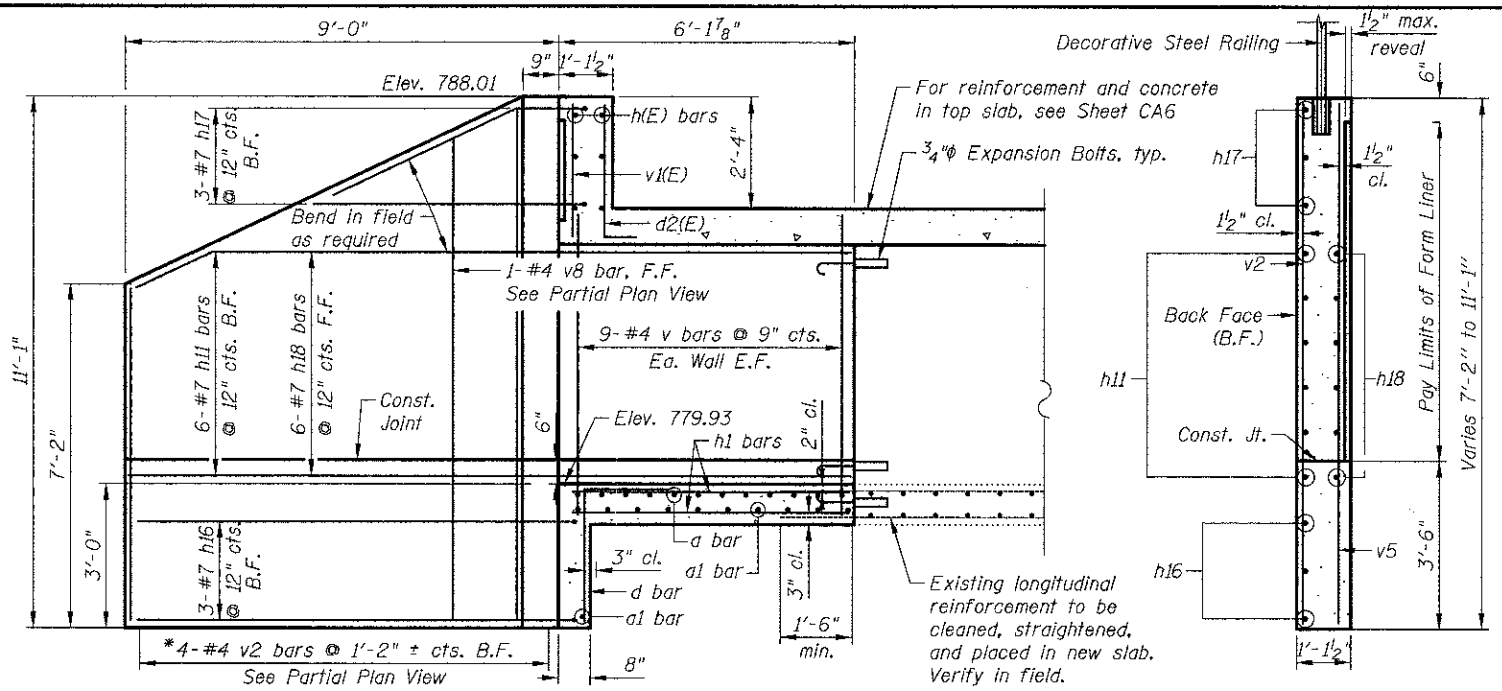

SOUTHWEST WINGWALL

* See Field Cutting Diagram on sheet CA6

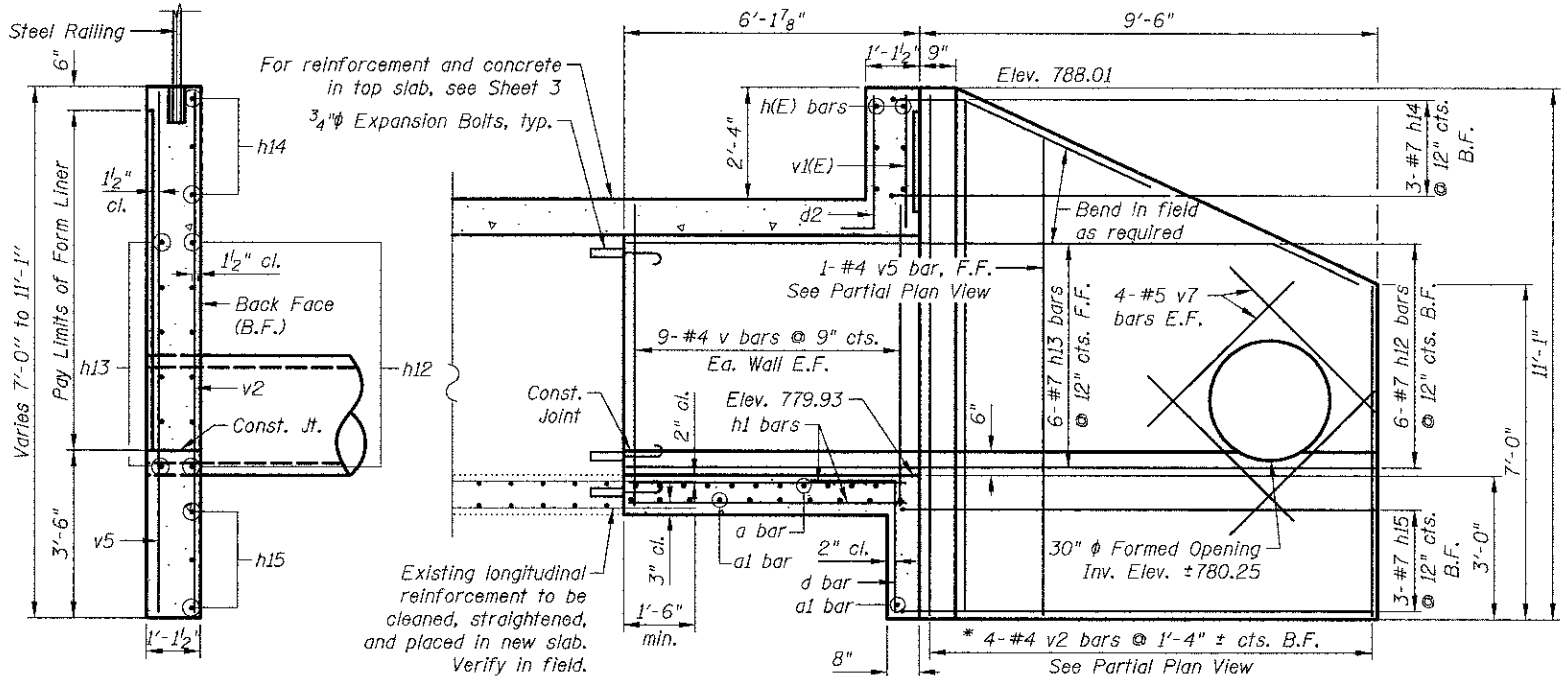

SECTION D-D

SOUTHEAST WINGWALL

* See Field Cutting Diagram on sheet CA6
Reinforcement bars that interfere with the formed opening in the wingwall shall be cut off to provide adequate clearance as approved by the Engineer.

12/17/2012 11:31:00 AM J:\244\road\016-6328\05_South_End_Section.r3d.dgn

33'-4" - 3 Cell Cast-in-Place Concrete Box Culvert

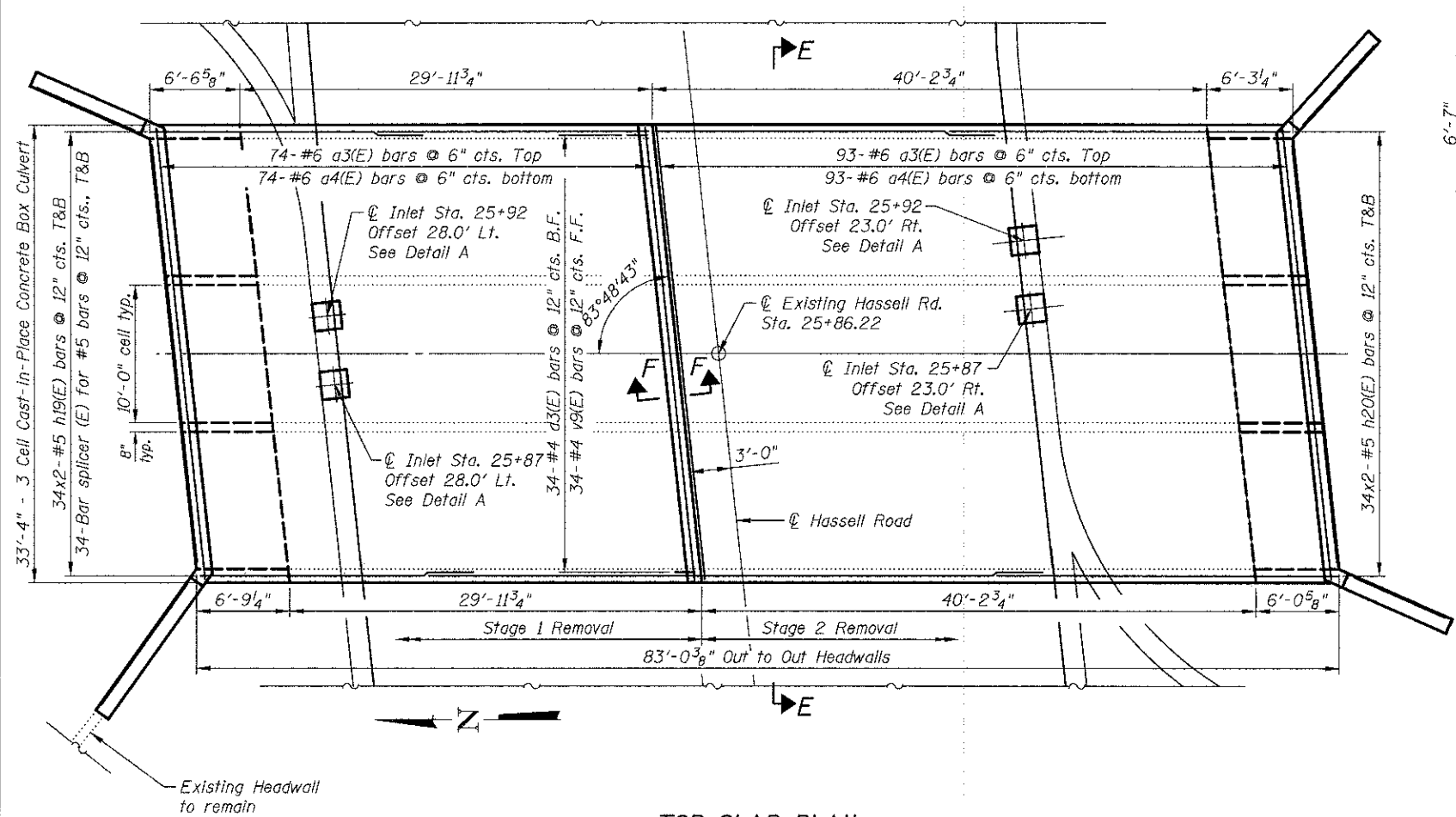

TOP SLAB PLAN

* Station and offsets are taken from the existing ϕ of Hassell Road

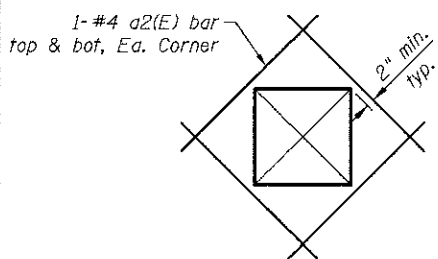

**DETAIL A
REINFORCEMENT AT INLET**

(Cut reinforcement to clear inlet)
(Adjust inlet to avoid culvert walls)

MINIMUM BAR LAP
(Top Slab)
#5 bar = 3'-3"

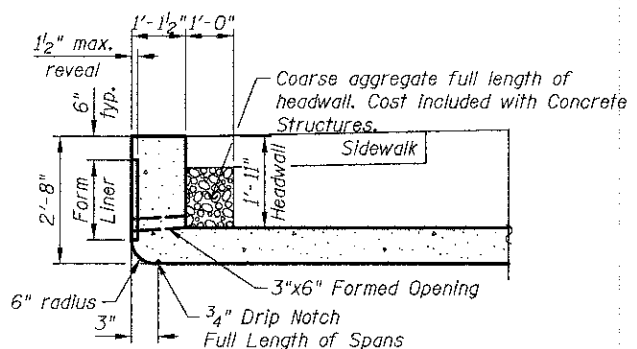

**SECTION THRU HEADWALL
UPSTREAM SIDE**
Reinforcement not shown

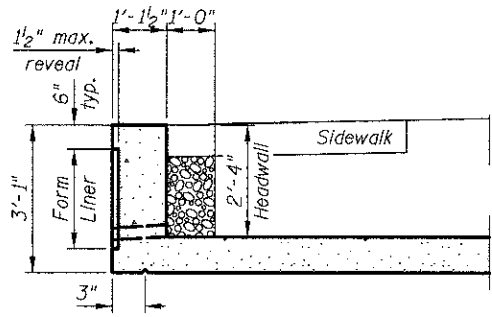

**SECTION THRU HEADWALL
DOWNSTREAM SIDE**
Reinforcement not shown
See upstream side for balance of information

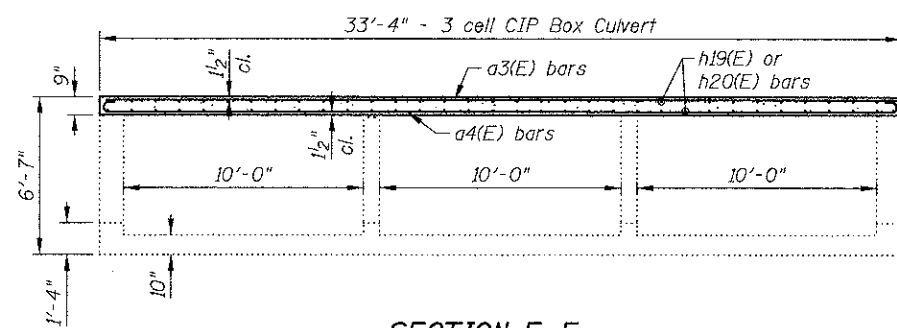

SECTION E-E

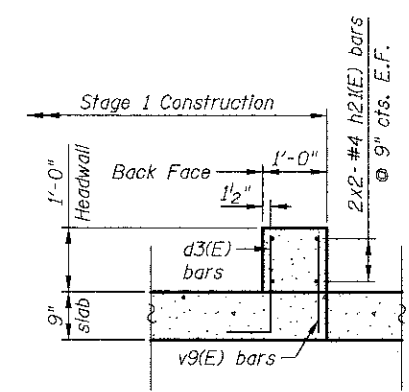

SECTION F-F

Top slab reinforcement not shown

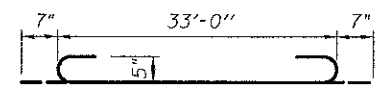

BARS a and a4(E)

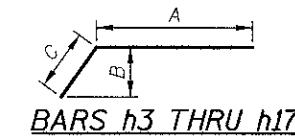

BARS h3 THRU h17

Bar	A	B	C
h3	11'-3"	1'-8 5/8"	4'-3"
h4	7'-9"	1'-2 1/2"	3'-0"
h5	13'-0"	4'-4 3/8"	5'-5"
h6	6'-11"	2'-5 3/8"	3'-0"
h7	5'-7"	2'-7 1/8"	3'-0"
h8	6'-10"	1'-11 1/8"	3'-0"
h9	9'-10"	2'-7 1/8"	3'-0"
h10	12'-10"	1'-11 1/8"	3'-0"
h11	10'-10"	1'-6 1/8"	3'-9"
h12	10'-0"	3'-6 3/8"	4'-9"
h13	6'-7"	2'-2 3/4"	3'-0"
h14	5'-7"	2'-2 3/4"	3'-0"
h15	9'-9"	2'-2 3/4"	3'-0"
h16	9'-5"	2'-7 1/8"	3'-0"
h17	5'-8"	2'-7 1/8"	3'-0"
h18	7'-3"	1'-2 1/2"	3'-0"

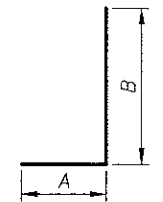

BARS d THRU d2(E)

Bar	A	B
d	1'-9"	2'-9"
d1(E)	0'-8"	2'-4"
d2(E)	0'-8"	2'-9"
d3(E)	0'-8"	1'-6"

End section of the barrel shall be poured monolithically with the wingwalls.
Bars indicated thus 12x4-#5 etc. indicates 12 lines of bars with 4 lengths per line.
All construction joints shall be bonded.

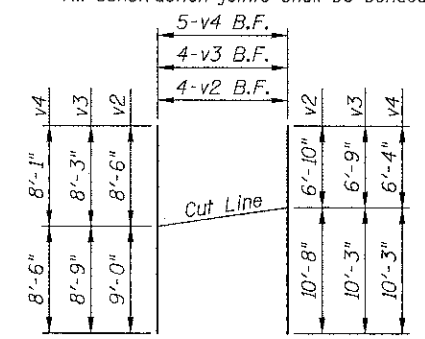

FIELD CUTTING DIAGRAM

BILL OF MATERIAL

Bar	No.	Size	Length	Shape
a	27	#6	34'-2"	U
a1	29	#6	33'-0"	—
a2(E)	32	#4	4'-0"	—
a3(E)	167	#6	33'-0"	—
a4(E)	167	#6	34'-2"	U
d	68	#4	4'-6"	—
d1(E)	34	#4	3'-0"	—
d2(E)	34	#4	3'-5"	—
d3(E)	34	#4	2'-2"	—
h(E)	10	#4	32'-3"	—
h1	88	#5	5'-10"	—
h2	88	#5	6'-4"	—
h3	6	#7	15'-6"	—
h4	6	#7	10'-9"	—
h5	7	#9	18'-5"	—
h6	7	#9	9'-11"	—
h7	2	#7	8'-7"	—
h8	3	#9	9'-10"	—
h9	3	#7	12'-10"	—
h10	4	#9	15'-10"	—
h11	6	#7	14'-7"	—
h12	6	#7	14'-9"	—
h13	6	#7	9'-7"	—
h14	3	#7	8'-7"	—
h15	3	#7	12'-9"	—
h16	3	#7	12'-5"	—
h17	3	#7	8'-8"	—
h18	6	#7	10'-3"	—
h19(E)	136	#5	19'-10"	—
h20(E)	136	#5	24'-8"	—
h21(E)	8	#4	17'-9"	—
v	152	#4	6'-3"	—
v1(E)	34	#4	2'-9"	—
v2	8	#4	17'-6"	—
v3	4	#4	17'-0"	—
v4	5	#4	16'-7"	—
v5	2	#4	9'-8"	—
v6(E)	34	#4	2'-4"	—
v7	8	#5	4'-3"	—
v8	2	#4	9'-2"	—
v9(E)	34	#4	1'-6"	—
Item	Unit	Quantity		
Concrete Box Culverts	Cu. Yd.	121.8		
Reinforcement Bars	Pound	7,310		
Reinforcement bars, Epoxy Coat	Pound	23,910		
Expansion Bolts 3/4"	Each	82		
Form Liner Textured Surface, Special	Sq. Ft.	274		

11/17/2012 11:31:02 AM J:\244\m\c\016-6328\06_Top_slab_and_Details.dgn

CIVILTECH
450 E Devon Ave, Suite 300
Itasca, Illinois 60143
Tel: 630.773.3900 Fax: 630.773.3975
www.civiltechinc.com

DRAWN - K. BOCHNOWSKI	REVISED -
DESIGNED - M. LANGE	REVISED -
CHECKED - G. HATLESTAD	REVISED -
DATE - DECEMBER 17, 2012	REVISED -

**STATE OF ILLINOIS
DEPARTMENT OF TRANSPORTATION**

**TOP SLAB DETAILS
HASSELL ROAD OVER POPLAR CREEK
STRUCTURE NO. 016-6328**

F.A.U. RTE.	SECTION	COUNTY	TOTAL SHEETS	SHEET NO.
1100	11-00087-00-FP	COOK	164	104
CONTRACT NO. 63770				
[ILLINOIS] FED. AID PROJECT CMM 9063(757)				

SHEET NO. CA6 OF CA9 SHEETS

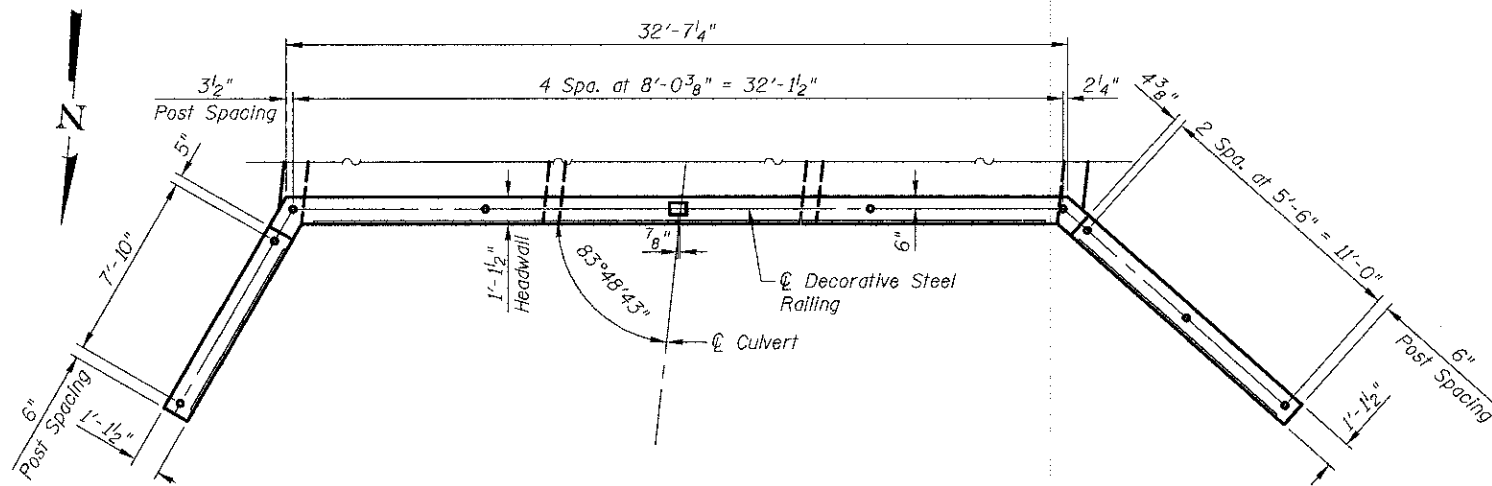

NORTH END PARTIAL PLAN

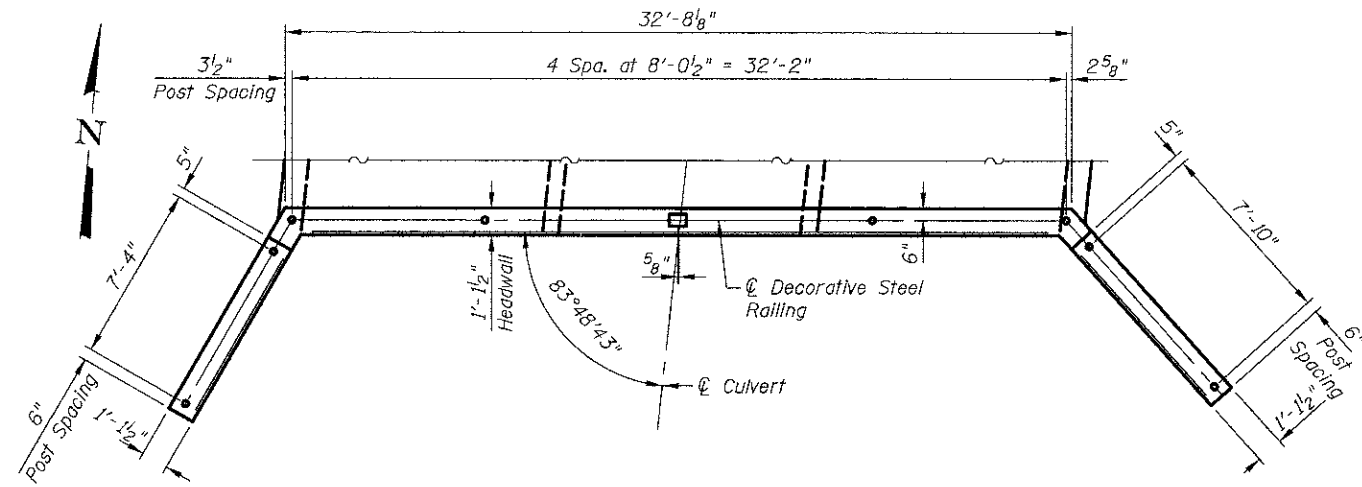

SOUTH END PARTIAL PLAN

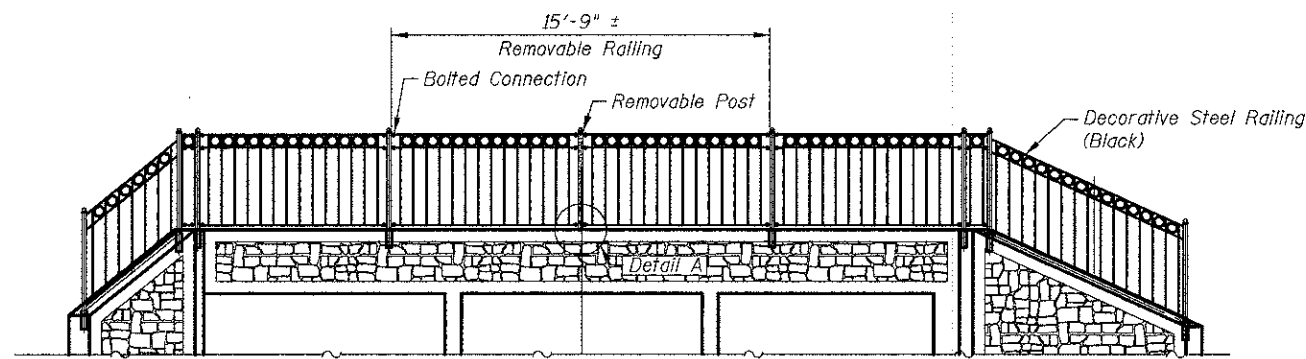

NORTH END VIEW - ELEVATION

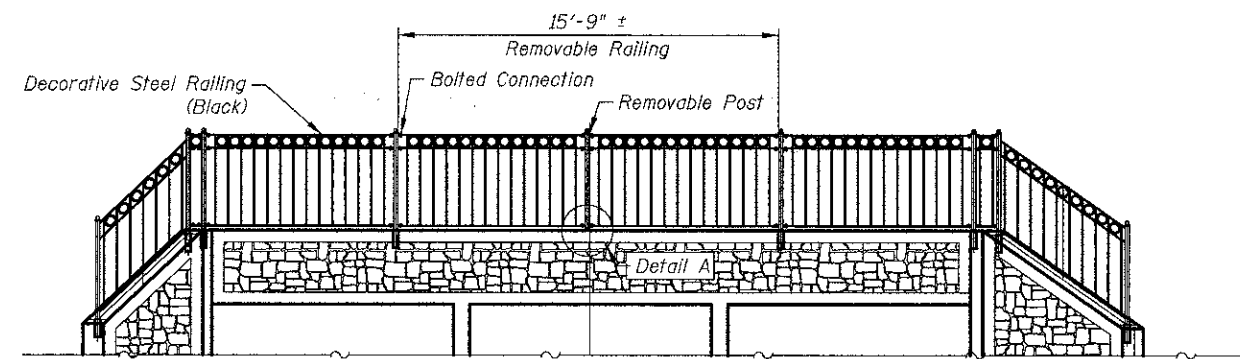

SOUTH END VIEW - ELEVATION

BILL OF MATERIAL

Item	Unit	Quantity
Decorative Steel Railing	Foot	105

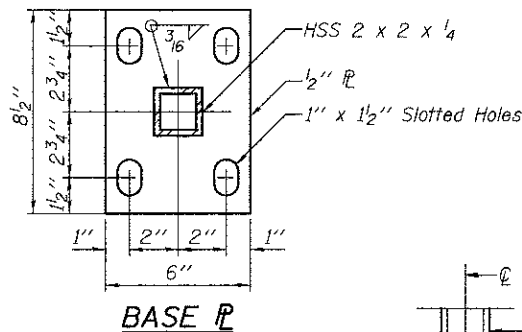

BASE R

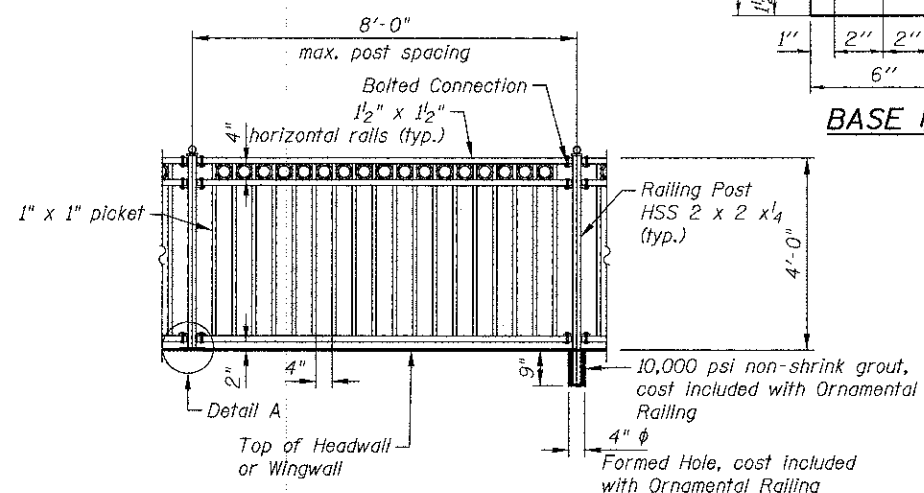

TYPICAL RAILING ELEVATION

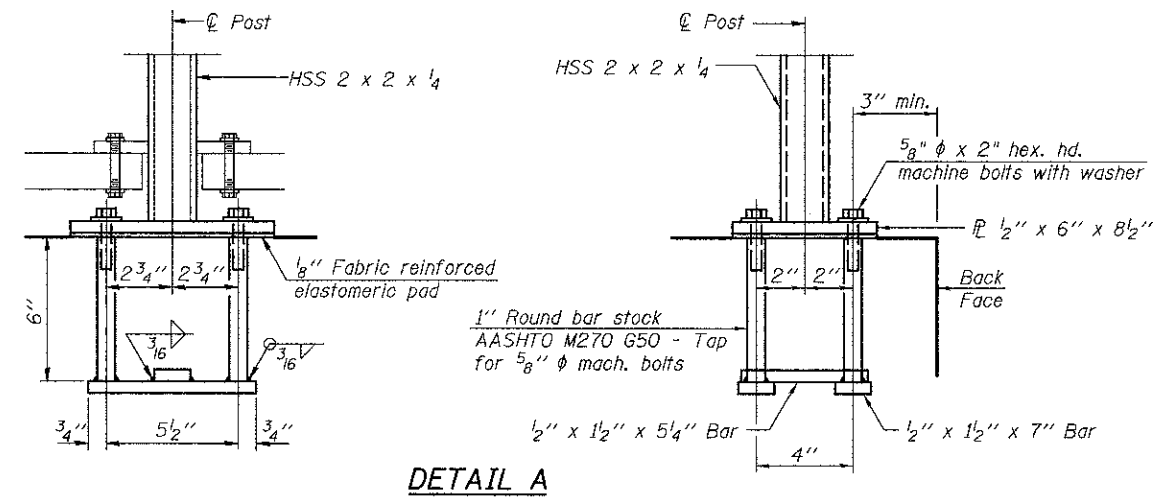

DETAIL A

12/12/2012 10:31:44 AM J:\244\ncad\016-6328\07_Railing_Details.dgn

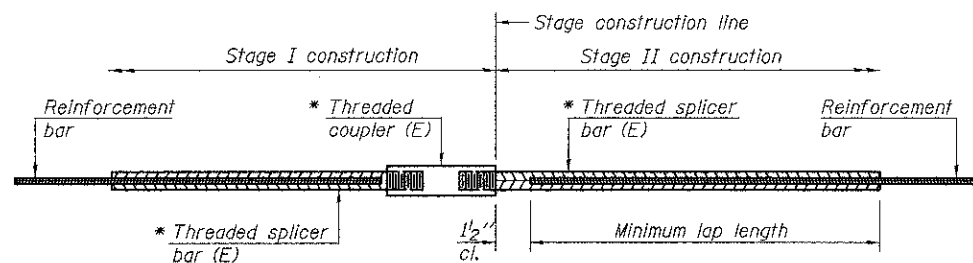

STANDARD BAR SPLICER ASSEMBLY

Bar size to be spliced	Minimum Lap Lengths					
	Table 1	Table 2	Table 3	Table 4	Table 5	Table 6
3, 4	1'-5"	1'-11"	2'-1"	2'-4"	2'-7"	2'-11"
5	1'-9"	2'-5"	2'-7"	2'-11"	3'-3"	3'-8"
6	2'-1"	2'-11"	3'-1"	3'-6"	3'-10"	4'-5"
7	2'-9"	3'-10"	4'-2"	4'-8"	5'-2"	5'-10"
8	3'-8"	5'-1"	5'-5"	6'-2"	6'-9"	7'-8"
9	4'-7"	6'-5"	6'-10"	7'-9"	8'-7"	9'-8"

- Table 1: Black bar, 0.8 Class C
- Table 2: Black bar, Top bar lap, 0.8 Class C
- Table 3: Epoxy bar, 0.8 Class C
- Table 4: Epoxy bar, Top bar lap, 0.8 Class C
- Table 5: Epoxy bar, Class C
- Table 6: Epoxy bar, Top bar top, Class C

Threaded splicer bar length = min. lap length + 1/2" + thread length

* Epoxy not required on Bar Splicer Assembly components used in conjunction with black bars.

Location	Bar size	No. assemblies required	Table for minimum lap length
Top Slab Stage Constr. Line	#5	68	Table 5

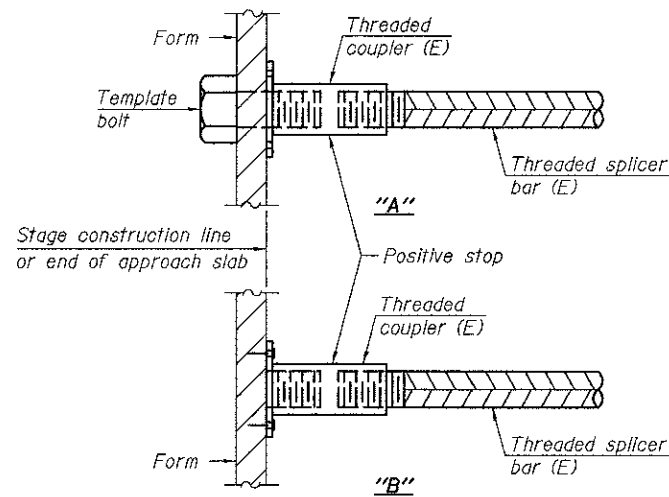

INSTALLATION AND SETTING METHODS

"A" : Set bar splicer assembly by means of a template bolt.
 "B" : Set bar splicer assembly by nailing to wood forms or cementing to steel forms.
 (E) : Indicates epoxy coating.

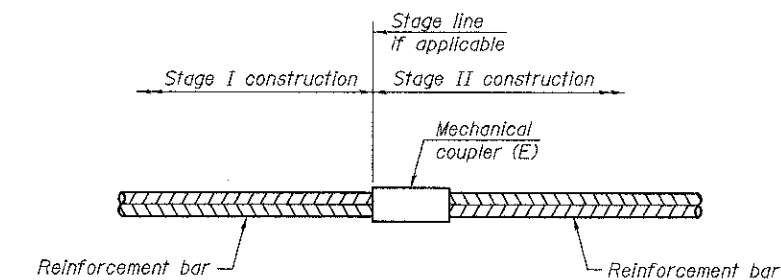

STANDARD MECHANICAL SPLICER

Location	Bar size	No. assemblies required

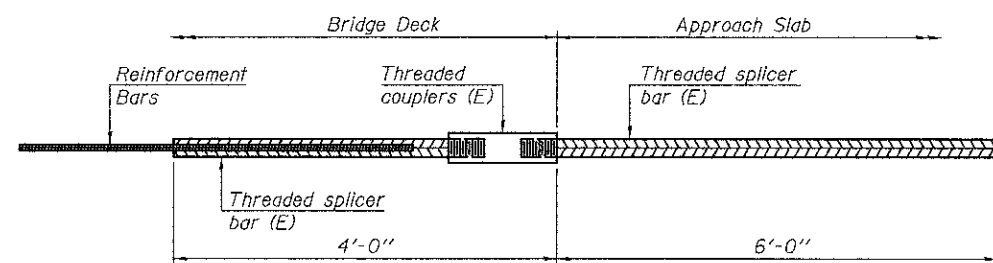

BAR SPLICER ASSEMBLY FOR #5 BAR ON INTEGRAL OR SEMI-INTEGRAL ABUTMENTS

No. required = 0

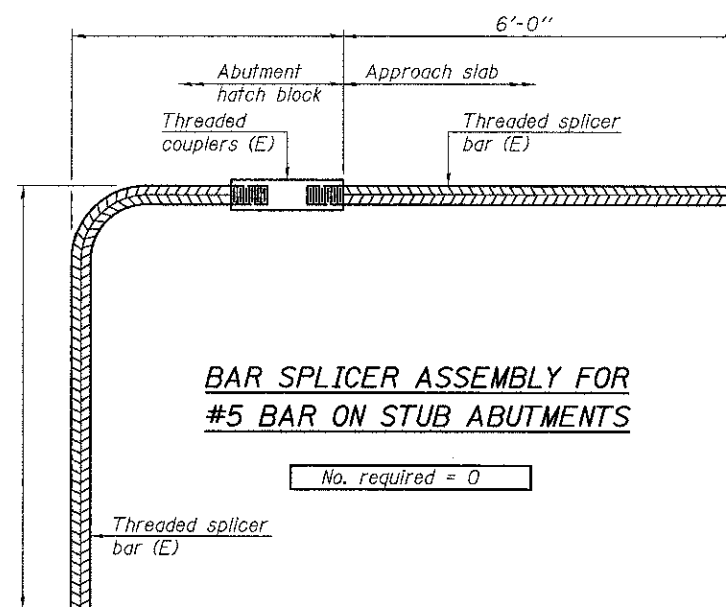

BAR SPLICER ASSEMBLY FOR #5 BAR ON STUB ABUTMENTS

No. required = 0

NOTES

Splicer bars shall be deformed with threaded ends and have a minimum 60 ksi yield strength.
 All reinforcement shall be lapped and tied to the splicer bars.
 Bar splicer assemblies shall be epoxy coated according to the requirements for reinforcement bars. See Section 508 of the Standard Specifications.
 See approved list of bar splicer assemblies and mechanical splicers for alternatives.

BSD-1

1-27-12



DRAWN - K. BOCHNOWSKI
 DESIGNED - M. LANGE
 CHECKED - G. HATLESTAD
 DATE - DECEMBER 17, 2012

REVISED -
 REVISED -
 REVISED -
 REVISED -

STATE OF ILLINOIS
 DEPARTMENT OF TRANSPORTATION

BAR SPLICER ASSEMBLY
 HASSELL ROAD OVER POPLAR CREEK
 STRUCTURE NO. 016-6328

SHEET NO. CAB OF CA9 SHEETS

F.A.U. RTE.	SECTION	COUNTY	TOTAL SHEETS	SHEET NO.
1100	11-00087-00-FP	COOK	164	106
CONTRACT NO. 63770				
[ILLINOIS] FED. AID PROJECT CMM 90031757				

MSET PROJECT NO.: 10452		LOG OF BORING NO. B-1		Page 1 of 1						
PROJECT: Hassel Road Culvert Replacement			SITE LOCATION: Hoffman Estates, IL							
BORING LOCATION: STA 26+15, 50' N of CL			CLIENT: Hey & Associates							
DEPTH (feet)	SOIL TYPE	Material Description	Elevation	SAMPLE		TESTS		REMARKS		
				TYPE/INTERVAL	NO.	N-VALUE Blows per ft.	Wc%		Dry Unit Weight, pcf	Unconfined Compressive Strength, tsf
0		Black and Brown Silty CLAY, little Sand and Gravel: fill, stiff to soft	790.1	SS	1	7	25	91	1.55	
5		mostly black, trace concrete		SS	2	7	19	100	1.24	
				SS	3	11	16	117	0.39	
10		Grey SAND (f-c), little to Some Gravel (SP), medium dense	780.3	SS	4	10	23	--	1.0 (p)	
				SS	5	12	11	--	--	
15		Grey SAND and GRAVEL (SP-GP), medium dense	777.1	SS	6	27	14	--	--	
				SS	7	29	6	--	--	
20				SS	8	22	10	--	--	
25				SS	9	23	7	--	--	
30		End of Boring @ 30'	760.1	SS	10	27	18	--	--	Hole Caved @ 11.4' upon completion

WATER LEVEL OBSERVATIONS, ft.
 DURING DRILLING: 11.0'
 IMMEDIATELY AFTER DRILLING: 10.5'
 DELAYED READING AFTER



BORING STARTED: 12/10/10
 BORING COMPLETED: 12/10/10
 LOGGED BY: SPE
 BORING METHOD: CFA

MSET PROJECT NO.: 10452		LOG OF BORING NO. B-2		Page 1 of 1						
PROJECT: Hassel Road Culvert Replacement			SITE LOCATION: Hoffman Estates, IL							
BORING LOCATION: STA 25+70, 35' S of CL			CLIENT: Hey & Associates							
DEPTH (feet)	SOIL TYPE	Material Description	Elevation	SAMPLE		TESTS		REMARKS		
				TYPE/INTERVAL	NO.	N-VALUE Blows per ft.	Wc%		Dry Unit Weight, pcf	Unconfined Compressive Strength, tsf
0		Black and Brown Silty CLAY, little Sand and Gravel: fill, stiff to firm	788.2	SS	1	8	21	100	1.94	
5				SS	2	6	18	--	1.5 (p)	
				SS	3	3	22	106	0.70	
10		Grey SAND (f-c), some Gravel, trace Silt (SP), wet, medium dense	778.7	SS	4	7	19	102	0.58	
				SS	5	12	17	--	--	
15				SS	6	13	14	--	--	
				SS	7	13	17	--	--	
20		Grey SAND and GRAVEL (SP-GP), medium dense	770.2	SS	8	18	10	--	--	
25				SS	9	24	6	--	--	
30		End of Boring @ 30'	758.2	SS	10	24	9	--	--	Hole Caved @ 9.7' upon completion

WATER LEVEL OBSERVATIONS, ft.
 DURING DRILLING: 9.5'
 IMMEDIATELY AFTER DRILLING: 9.4'
 DELAYED READING AFTER



BORING STARTED: 12/10/10
 BORING COMPLETED: 12/10/10
 LOGGED BY: SPE
 BORING METHOD: CFA

12/12/2012 11:24:24 AM J:\2441\road\016-6328\09_Soil Bor-Ing_Logs.dgn

Benchmark: Temporary bench mark in the park southwest of the culverts, Elevation 796.51 feet.

Datum = NGVD29

Existing Structure: SN 016-6327 built in 1970 as twin CMP Pipe Arches, approximate out-to-out width of 25'-6", and approximately 86'-4" in length.

Traffic: Traffic will be detoured during construction.

General Notes

1. Precast concrete box culvert sections shall conform to the requirements of ASTM C1577.
2. Lifting holes shall be filled with concrete plugs and mastic after the box sections are in place.
3. Diversion of stream flow during the removal of the existing culvert and the construction of the proposed culvert and all required erosion control measures shall be considered as included in concrete box culverts and no additional compensation will be allowed.

Total Bill of Material

ITEM	UNIT	QUANTITY
REMOVAL AND DISPOSAL OF UNSUITABLE MATERIAL	CU YD	272
TRENCH BACKFILL	CU YD	32
POROUS GRANULAR BACKFILL	CU YD	361
AGGREGATE BASE COURSE, TYPE B 6"	SQ YD	15
PORTLAND CEMENT CONCRETE PAVEMENT 6"	SQ YD	15
BRIDGE RAIL REMOVAL	FOOT	94
PIPE CULVERT REMOVAL	FOOT	173
REINFORCEMENT BARS	POUND	4,060
REINFORCEMENT BARS, EPOXY COATED	POUND	1,010
NAME PLATES	EACH	1
BOX CULVERT END SECTIONS, CULVERT NO. 1	EACH	2
PRECAST CONCRETE BOX CULVERTS 10' X 6'	FOOT	150
CONCRETE COLLAR	CU YD	1
STORM SEWER REMOVAL 10"	FOOT	6
STORM SEWER REMOVAL 21"	FOOT	20
STORM SEWERS, CLASS A, TYPE 2 21"	FOOT	22
STORM SEWERS, CLASS B, TYPE 2 10"	FOOT	11
DECORATIVE STEEL RAILING	FOOT	103
FORM LINER TEXTURED SURFACE, SPECIAL	SQ FT	420

Sheet No.

- CB1
- CB2
- CB3
- CB4
- CB5
- CB6
- CB7

Index of Sheets

- General Plan & Longitudinal Section
- South End Section
- South End Section Details
- North End Section
- North End Section Details
- Decorative Steel Railing Details
- Soil Boring Logs

PLAN	DATE	BY
REVISED		
NOTED		
NO.		

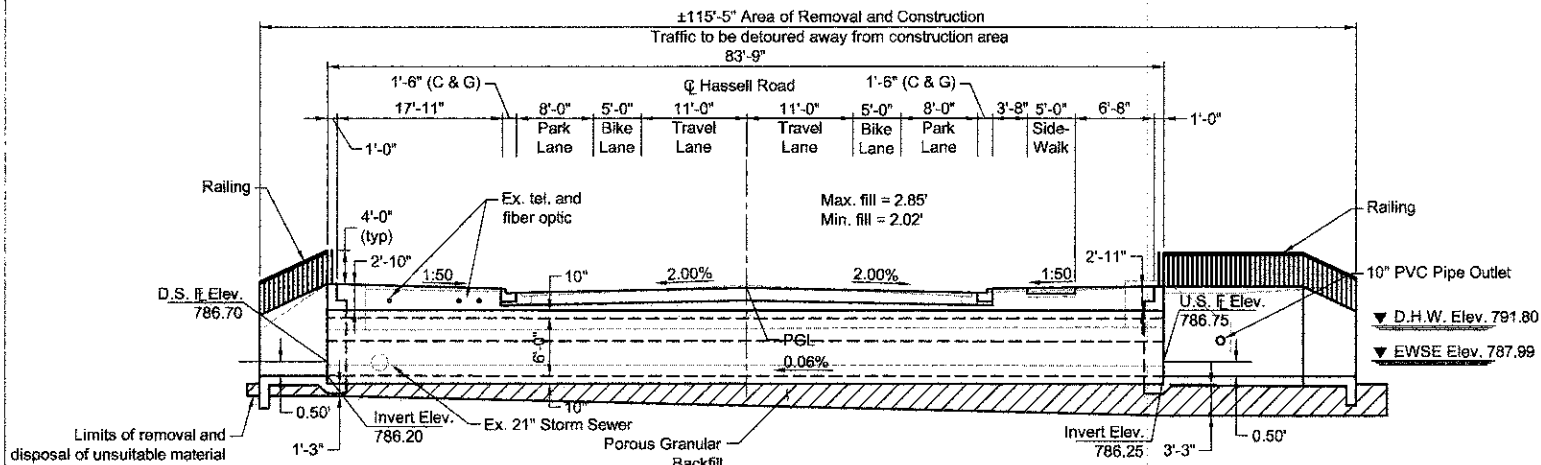

Longitudinal Section

Note: Dimensions at right angles to Centerline of Roadway unless otherwise noted.

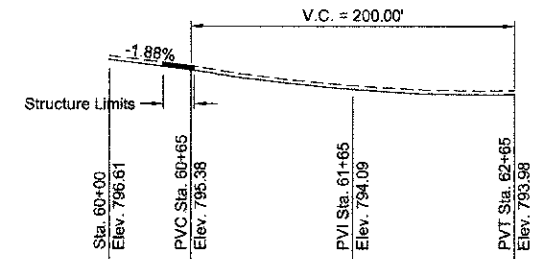

Profile Grade

(along Q roadway)

Waterway Information Table

Flood		Frequency Year	Discharge (cfs)	Waterway Opening (sq. ft.) Existing	Waterway Opening (sq. ft.) Proposed	Natural H.W.E.	Created Head (ft.) Existing	Created Head (ft.) Proposed	Headwater Elev. Existing	Headwater Elev. Proposed
Design		10	215.00	86.2	101.6	791.33	0.00	0.00	791.33	791.33
Base		50	270.00	86.4	111.0	791.80	0.04	0.00	791.84	791.80
Max Calc.		100	340.00	86.4	114.0	791.95	0.07	0.00	792.02	791.95
		500	400.00	86.4	117.2	792.29	0.15	0.00	792.44	792.29
			555.00	86.4	117.2	792.69	0.36	0.00	793.05	792.69

C/L CURVE DATA
 PC=STA 58+96.90
 PT=STA 62+20.33
 R=1432.69'
 D=3° 59' 57"
 L=323.43'
 C=322.74'
 T=161.37'

PROFILE	DATE	BY
REVISED		
NOTED		
NO.		

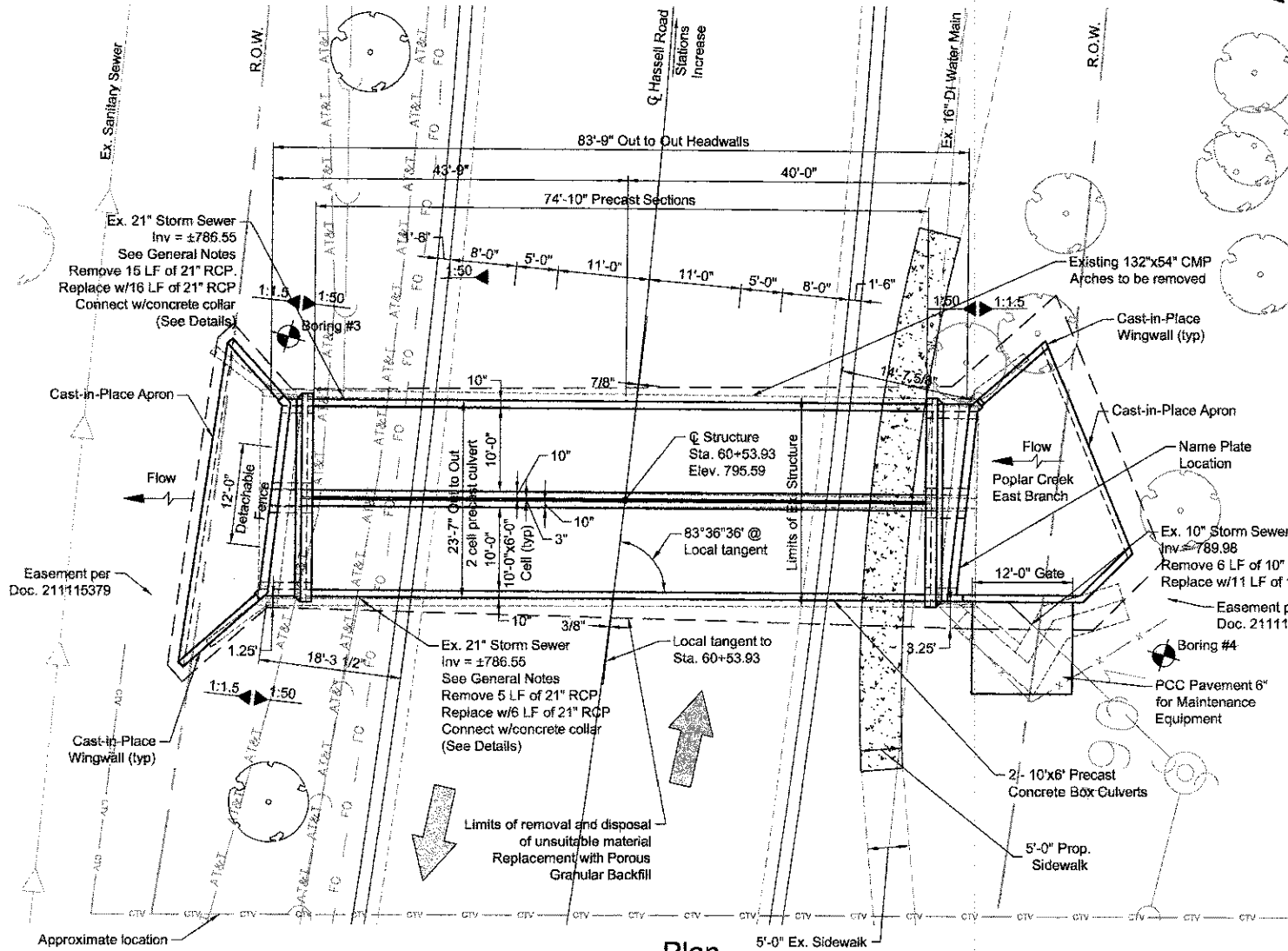

Plan

Note: Dimensions at right angles to Centerline of Roadway unless otherwise depicted.

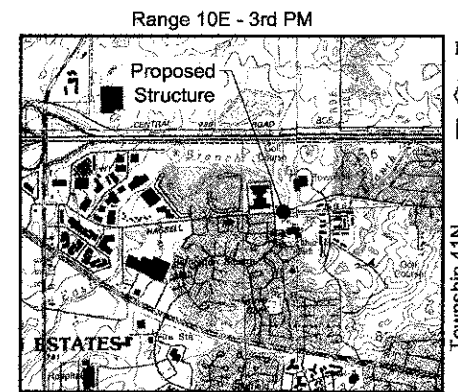

Location Sketch

Loading HL-93
 Allow 50#/sq-ft for future wearing surface.

Design Specifications
 2012 AASHTO LRFD Bridge Design Specifications, 6th Edition

Design Stresses

- Field Units
- f_c = 5,000 psi (pre-cast)
- f_c = 3,500 psi (cast in place)
- f_y = 60,000 psi (reinforcement)
- f_y = 65,000 psi (welded wire fabric)

CIVILTECH ENGINEERING, INC.
 GREGORY J. HATLESTAD, S.E.



GREGORY J. HATLESTAD, S.E.
 # 081-05585

EXP 11/30/2014

DATE 12/14/2012

I certify that to the best knowledge, information and belief, this box culvert design is structurally adequate for the design loading shown on the shown plans. The design is an economical one for the style of the structure and complies with the requirements of the current AASHTO LRFD Bridge Design Specifications of Highway Bridges.

Station	Offset
60+71.52	38.06' RT
60+81.24	47.34' RT
60+54.30	62.59' RT
60+46.35	55.99' RT
60+34.72	41.73' LT
60+23.81	50.90' LT
60+26.47	53.88' LT
60+68.26	52.73' LT
60+71.11	50.20' LT
60+63.44	42.09' LT

Limits of Removal/Disposal

Station 60+54
 Built 201_ by Hoffman Estates Loading HL-93 Structure No. 016-6344

Name Plate
 See Std. 515001

General Plan & Longitudinal Section

Hassell Road over
 Poplar Creek East Branch
 F.A.U. Rt. 1100
 Section 11-00087-00-FP
 Cook County
 Station 60+53.93
 Structure No. 016-6344

FILE NAME -
 Hassell Plan-Profile.dwg

DESIGNED -	REVISED -
DRAWN -	REVISED -
CHECKED -	REVISED -
DATE -	REVISED -

STATE OF ILLINOIS
 DEPARTMENT OF TRANSPORTATION

Hassell Road STP Project
 Structure No. 016-6344

SCALE: 1" = 10' SHEET NO. CB1 OF CB7 SHEETS STA. TO STA.

F.A.U. RTE.	SECTION	COUNTY	TOTAL SHEETS	SHEET NO.
1100	11-00087-00-FP	Cook	164	108

CONTRACT NO. 63770
 ILLINOIS FED. AID PROJECT CMM 9003(757)

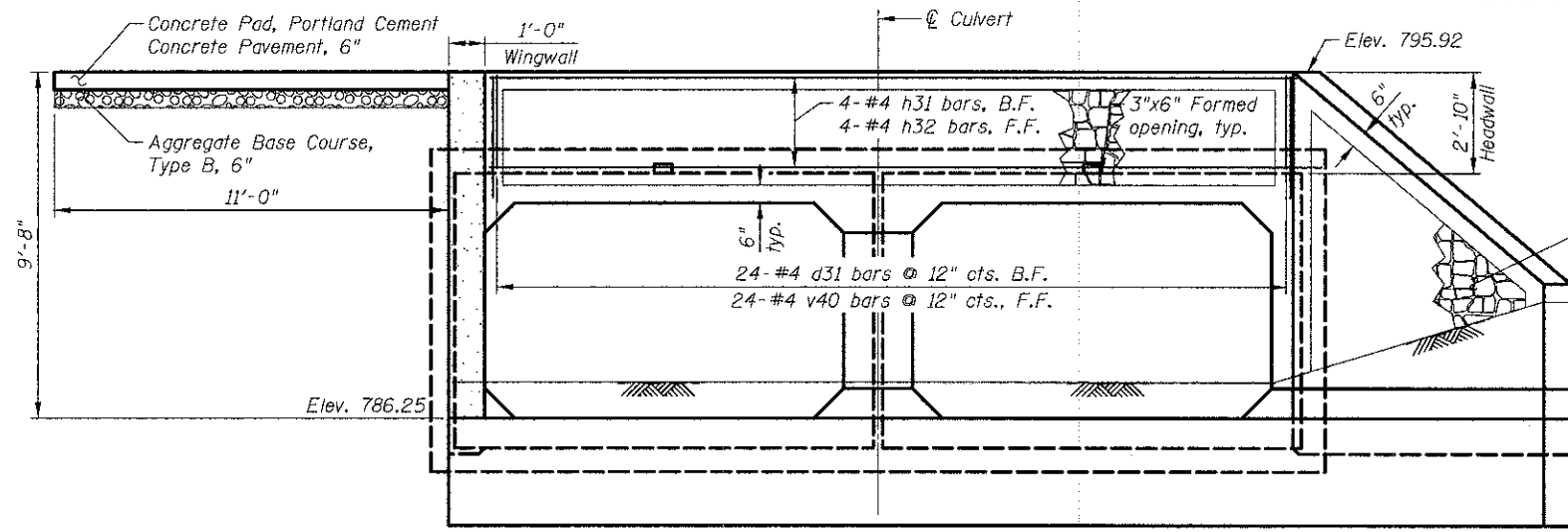

VIEW E-E

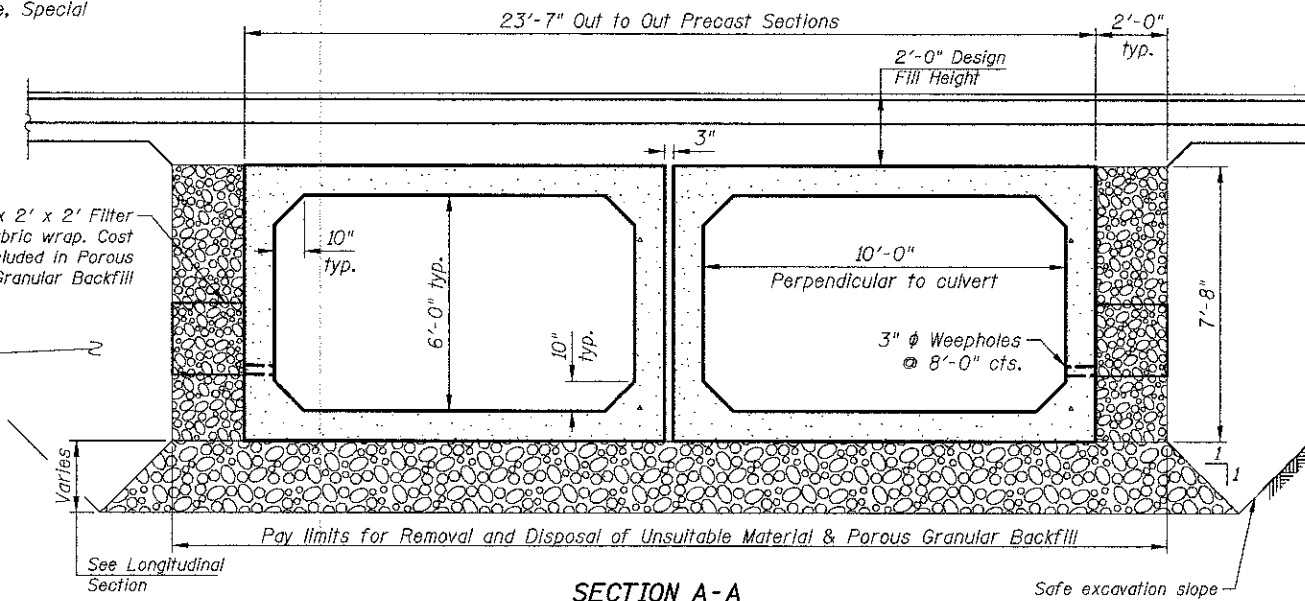

SECTION A-A

Excavation and Removal of Soil for Box Culverts shall not be paid for separately but shall be included in cost of Precast Concrete Box Culverts (Section 540.06 Standard Specifications)

See Longitudinal Section

Safe excavation slope as determined by Contractor, typ.

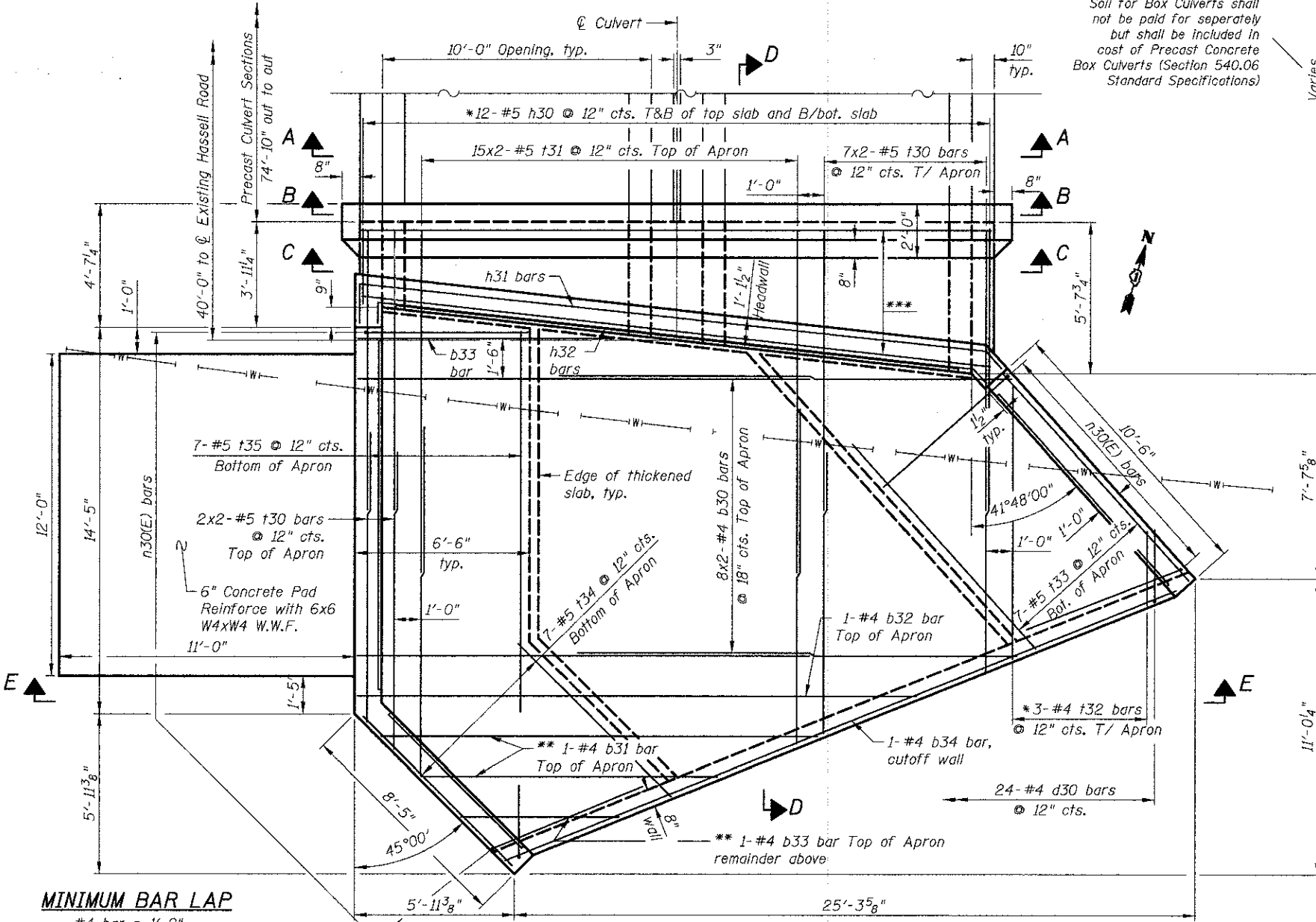

PARTIAL PLAN (South end section)

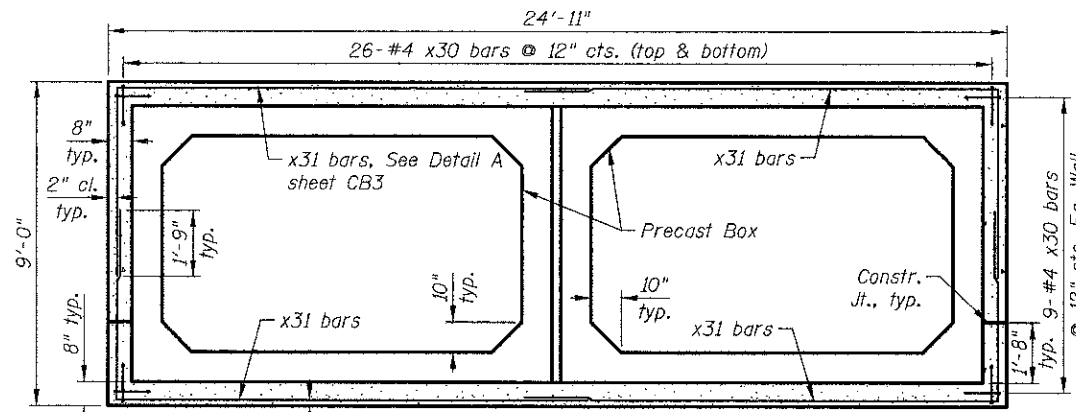

SECTION B-B

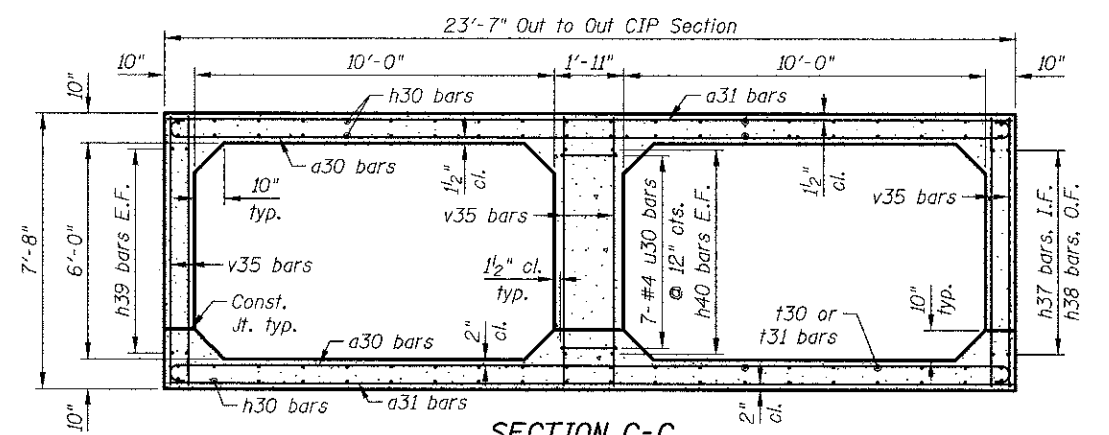

SECTION C-C

MINIMUM BAR LAP
 #4 bar = 1'-9"
 #5 bar = 2'-2"
 #6(E) bar = 3'-10"

* See Field cutting Diagram on sheet CB3.
 ** Order b31 and b33 bar full length, cut to fit and use the remainder as designated.

Notes:
 See sheet CB3 for sections D-D and E-E.
 Bars indicated thus 8x2-#4 etc. indicates 8 lines of bars with 2 lengths per line.

J:\2441\road\016-6344\02-End Section Layout.dgn
 12/12/2012 8:31:49 AM

CIVILTECH
 460 E Devon Ave, Suite 300
 Itasca, Illinois 60143
 Tel: 630.773.3900 Fax: 630.773.3975
 www.civiltechinc.com

DRAWN	- M. LANGE	REVISED	-
DESIGNED	- D. ATKINS	REVISED	-
CHECKED	- G. HATLESTAD	REVISED	-
DATE	- DECEMBER 17, 2012	REVISED	-

STATE OF ILLINOIS
 DEPARTMENT OF TRANSPORTATION

SOUTH END SECTION
 HASSELL ROAD OVER POPLAR CREEK
 STRUCTURE NO. 016-6344
 SHEET NO. CB2 OF CB7 SHEETS

F.A.U. RTE.	SECTION	COUNTY	TOTAL SHEETS NO.
1100	11-00087-00-FP	COOK	164 109
			CONTRACT NO. 63770

ILLINOIS FED. AID PROJECT CMM 90037571

FOR INFORMATION ONLY

Bar	No.	Size	Length	Shape
a30	22	#6	24'-7"	┌
a31	22	#6	23'-3"	┌
b30	16	#4	16'-2"	—
b31	1	#4	24'-9"	—
b32	1	#4	19'-11"	—
b33	1	#4	15'-6"	—
b34	1	#4	27'-6"	—
d30	24	#4	4'-6"	└
d31	24	#4	4'-0"	└
h30	36	#5	8'-2"	—
h31	4	#4	25'-11"	┌
h32	4	#4	23'-11"	┌
h33	10	#4	22'-4"	┌
h34	10	#4	22'-0"	┌
h35	5	#4	9'-6"	┌
h36	10	#4	10'-2"	┌
h37	7	#5	5'-11"	┌
h38	7	#5	5'-5"	┌
h39	14	#5	3'-7"	┌
h40	14	#5	4'-1"	┌
h41	2	#4	11'-6"	┌
h42	2	#4	9'-5"	┌
n30(E)	34	#6	11'-8"	└
t30	18	#5	10'-9"	—
t31	30	#5	12'-9"	—
t32	3	#5	13'-4"	—
t33	7	#5	10'-2"	—
t34	7	#5	8'-0"	—
t35	7	#5	14'-0"	—
u30	7	#4	3'-8"	U
v30	16	#5	8'-6"	—
v31	17	#4	9'-6"	—
v32	4	#5	13'-4"	—
v33	1	#5	4'-5"	—
v34	5	#4	13'-3"	—
v35	14	#5	7'-4"	—
v36	3	#4	13'-4"	—
v37	4	#4	13'-11"	—
v38	4	#4	2'-0"	—
v39	1	#4	3'-10"	—
v40	1	#4	3'-3"	—
x30	70	#4	5'-1"	┌
x31	12	#4	18'-5"	┌
Item				
Concrete Structures	Cu. Yd.	40.4		
Reinforcement Bars	Pound	4,830		
Reinforcement Bars, Epoxy Coated	Pound	600		

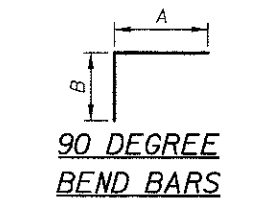

Bar	A	B
d30	2'-9"	1'-9"
d31	3'-4"	8"
n30(E)	6'-1"	5'-7"
x31	13'-2"	5'-3"

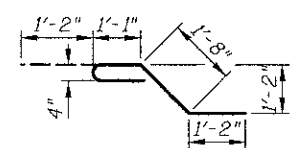

Bar	A	B	C
h33	14'-2"	8'-2"	5'-9 1/4"
h34	14'-0"	8'-0"	5'-7 3/8"
h37	5'-5"	6"	4 1/2"
h38	4'-9"	8"	6"

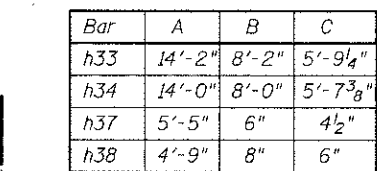

4-v37 bars
3-v36 bars
6-v34 bars
4-v32 bars
3-t32 bars
12-h30 bars

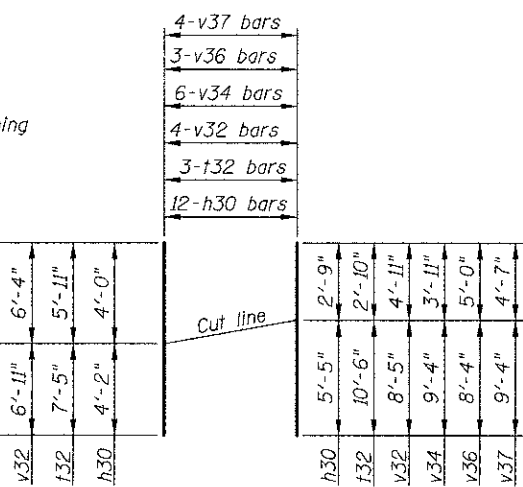
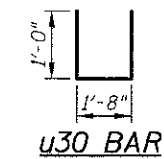

FIELD CUTTING DIAGRAM

BILL OF MATERIAL

Item	Unit	Quantity
Aggregate Base Course, Type B 6"	Sq. Yd.	15
Portland Cement Concrete Pavement, 6"	Sq. Yd.	15
Box Culvert End Section, Culvert No. 1	Ea.	1
Form Liner Textured Surface, Special	Sq. Ft.	254

Note: Quantity of concrete structures and reinforcement bars is shown for information only. The cost is included in Box Culvert End Section, Culvert No. 1.

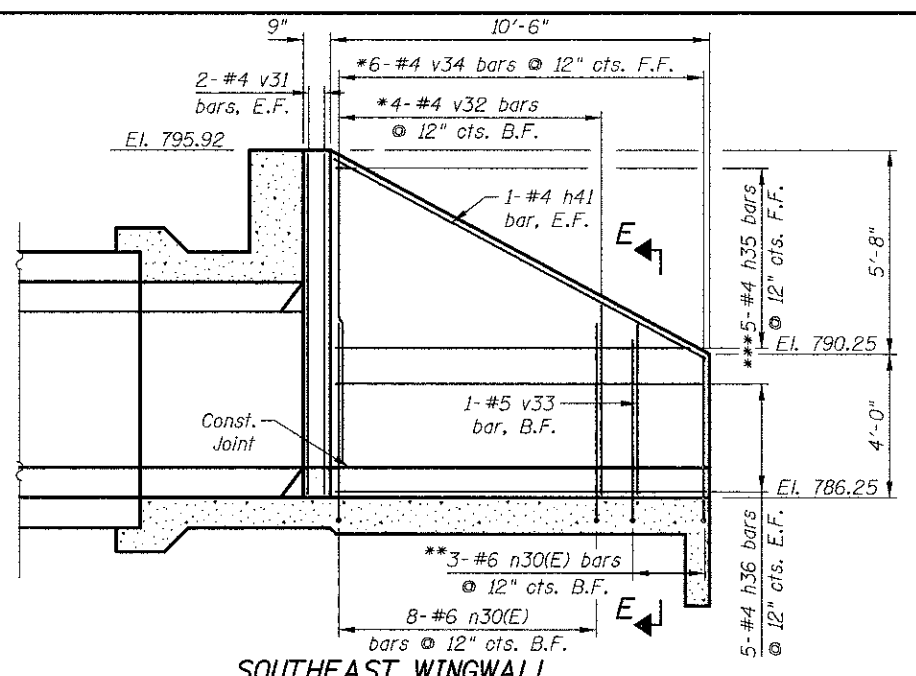

SOUTHEAST WINGWALL

** Field cut as required
*** Cut bars to fit in field. Use remainder in back face of wingwall.

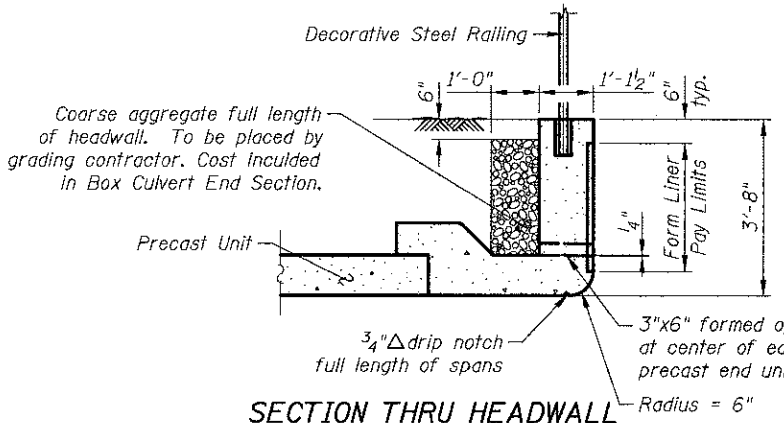

SECTION THRU HEADWALL (Upstream End)

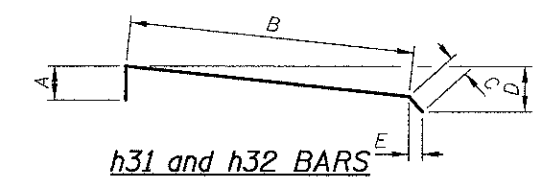

Bar	A	B	C	D	E
h31	1'-8"	23'-4"	0'-11"	3'-3 3/8"	7 3/8"
h32	0'-11"	22'-2"	0'-10"	3'-1"	6 5/8"

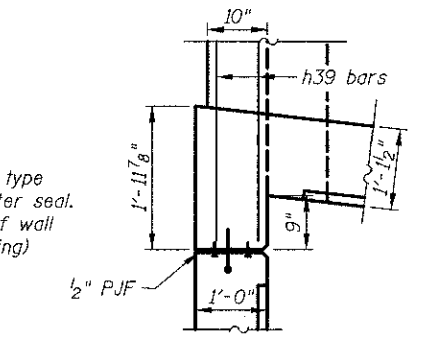

SOUTHWEST CORNER DETAIL

See SE corner for balance of information

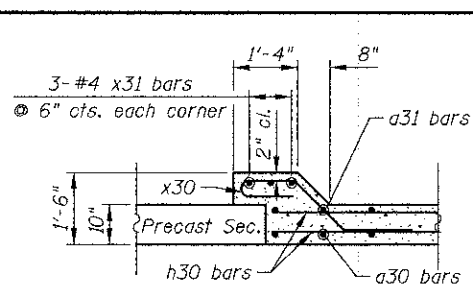

DETAIL "A"

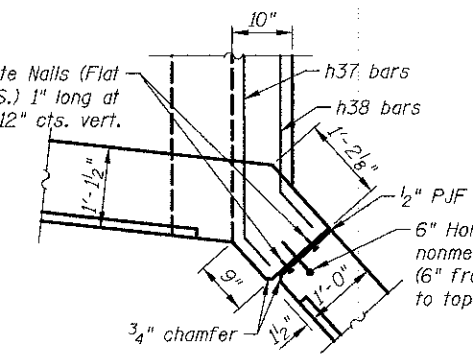

SOUTHEAST CORNER DETAIL

Water seal and concrete nails are cost included with Concrete Box Culvert End Section

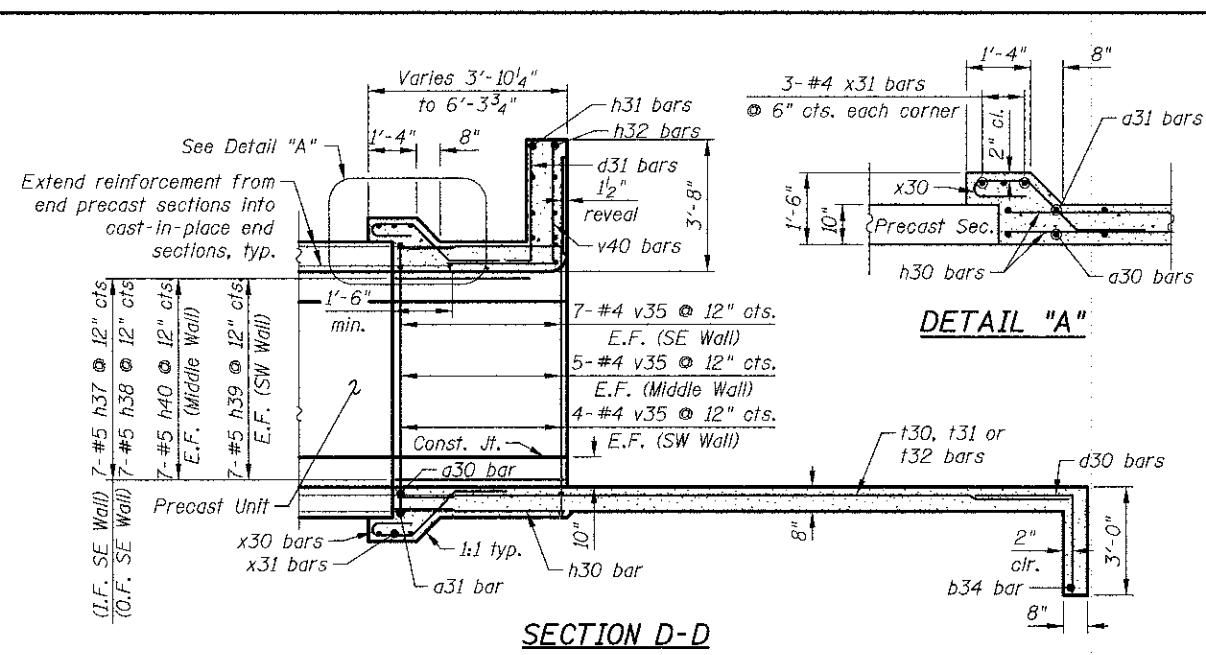

SECTION D-D

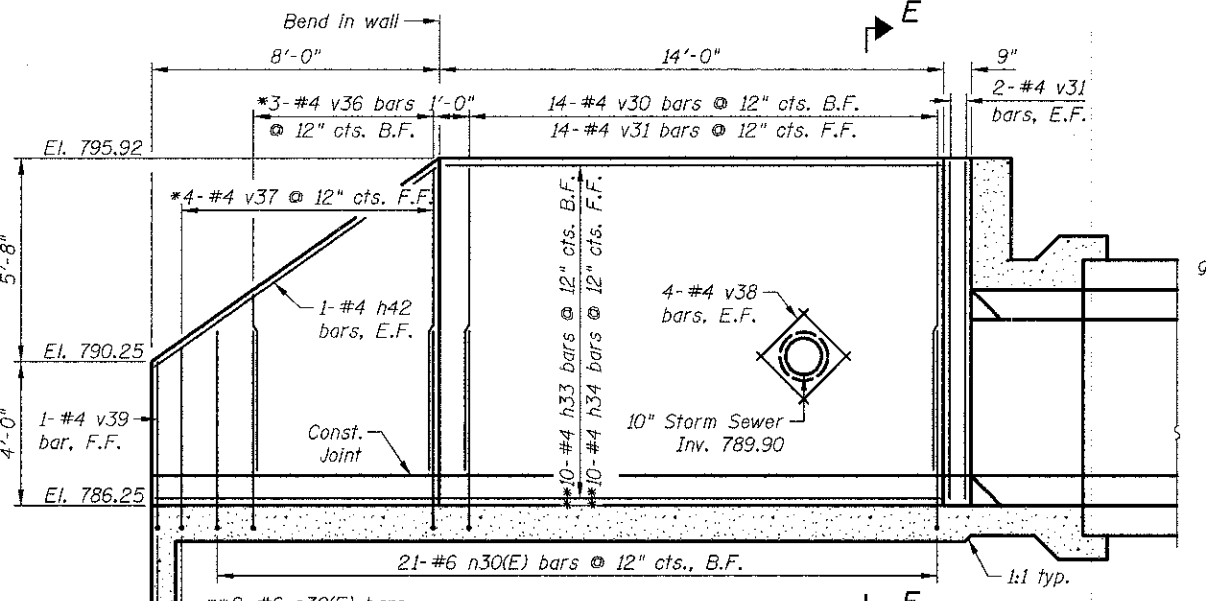

SOUTHWEST WINGWALL

* See field cutting diagram
** Field cut as required

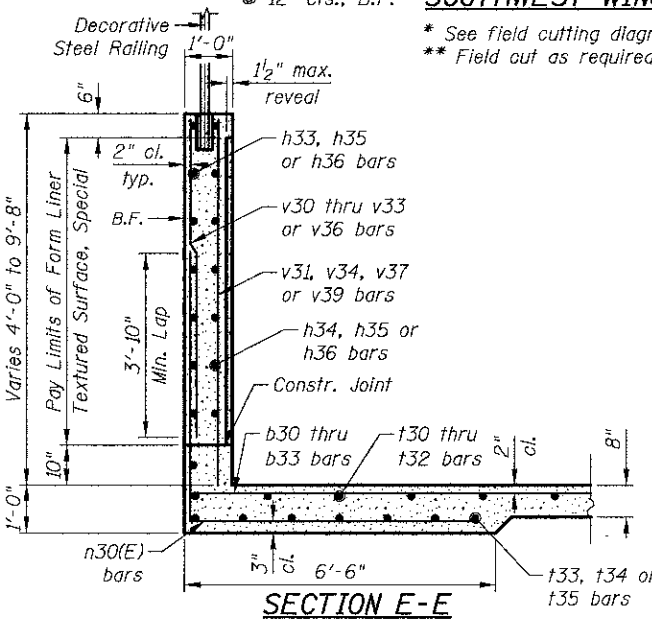

SECTION E-E

11/2/2012 11:51 AM
 I:\244\road\016-6344\03_End Section_1Details_south.dgn

CIVILTECH
 450 E Devon Ave, Suite 300
 Itasca, Illinois 60143
 Tel: 630.773.3900 Fax: 630.773.3975
 www.civiltechinc.com

DRAWN - M. LANGE	REVISED -
DESIGNED - D. ATKINS	REVISED -
CHECKED - G. HATLESTAD	REVISED -
DATE - DECEMBER 17, 2012	REVISED -

STATE OF ILLINOIS DEPARTMENT OF TRANSPORTATION

SOUTH END SECTION DETAILS HASSELL ROAD OVER POPLAR CREEK STRUCTURE NO. 016-6344

SHEET NO. CB3 OF CB7 SHEETS

F.A.U. RTE.	SECTION	COUNTY	TOTAL SHEETS	SHEET NO.
1100	11-00087-00-FP	COOK	164	110
				CONTRACT NO. 63170
ILLINOIS FED. AID PROJECT CMM 9003767				

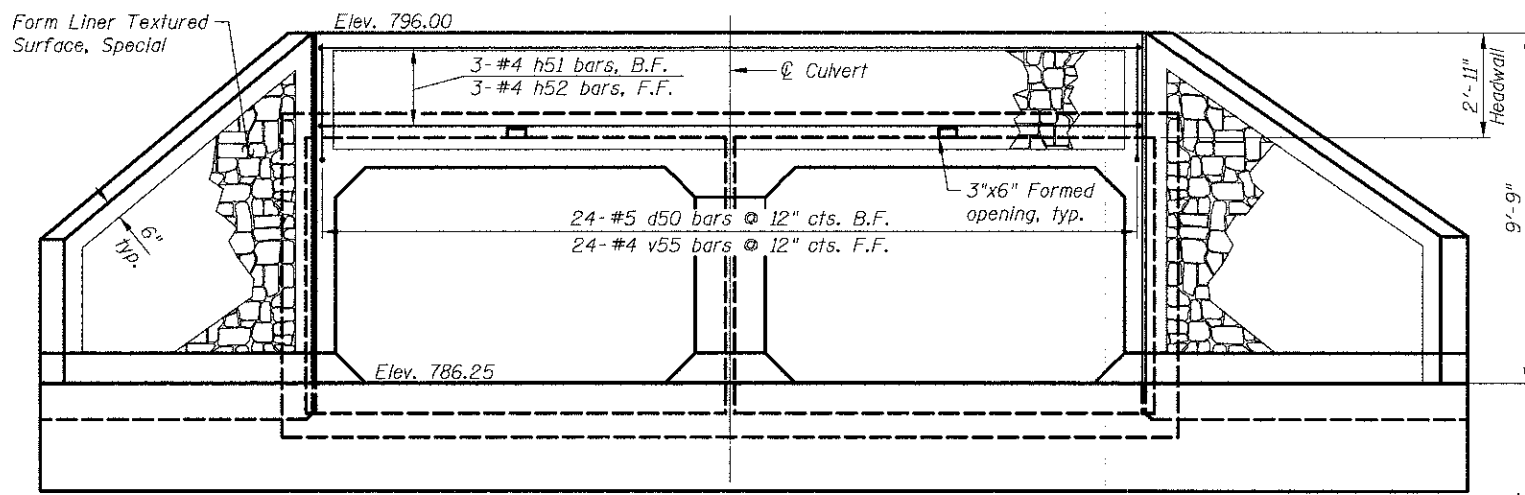

END ELEVATION
(North end)

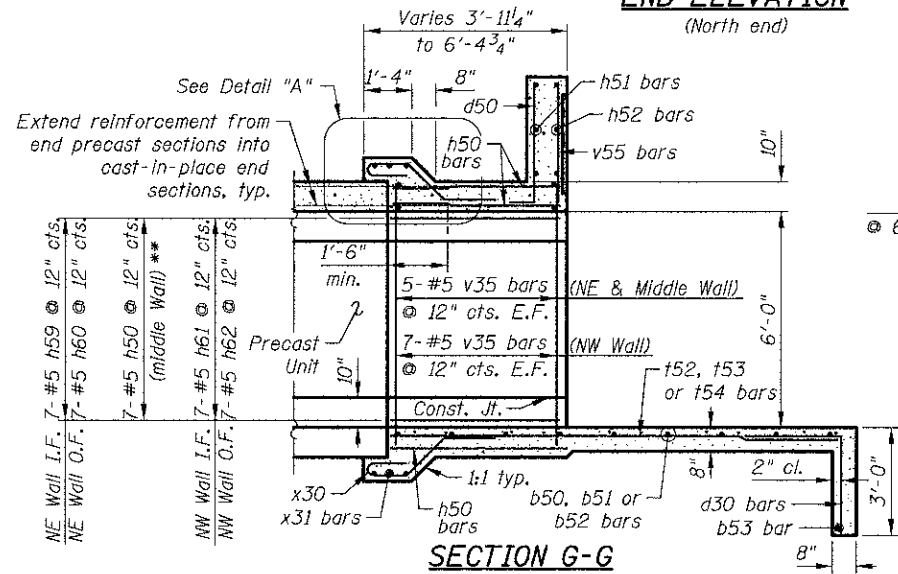

SECTION G-G

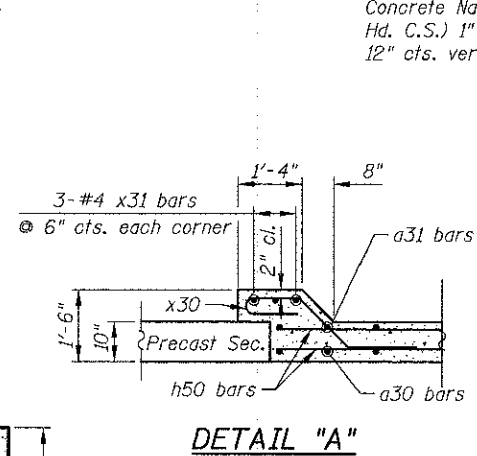

DETAIL "A"

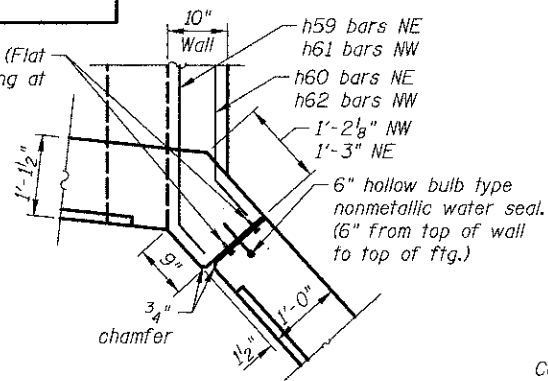

CORNER DETAIL

Water seal and concrete nails are cost included with Concrete Box Culvert End Section

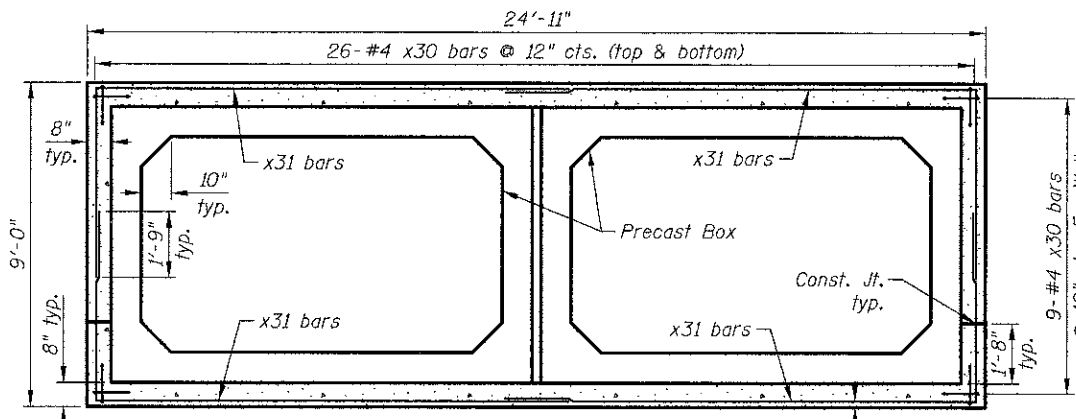

SECTION H-H

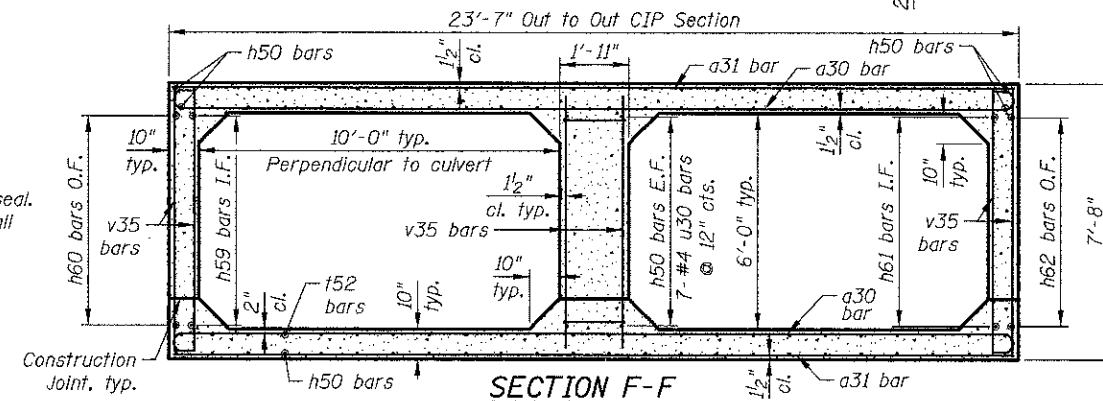

SECTION F-F

* See Field Cutting Diagram on sheet CB5.
** Order b52 and h50 bars full length. Cut to fit and use remainder as designated.

Notes:
Bars indicated thus 4x2-#4 etc. indicates 4 lines of bars with 2 lengths per line.
See sheet CB2 for Section A-A.

MINIMUM BAR LAP

#4 bar = 1'-9"
#6(E) bar = 3'-10"

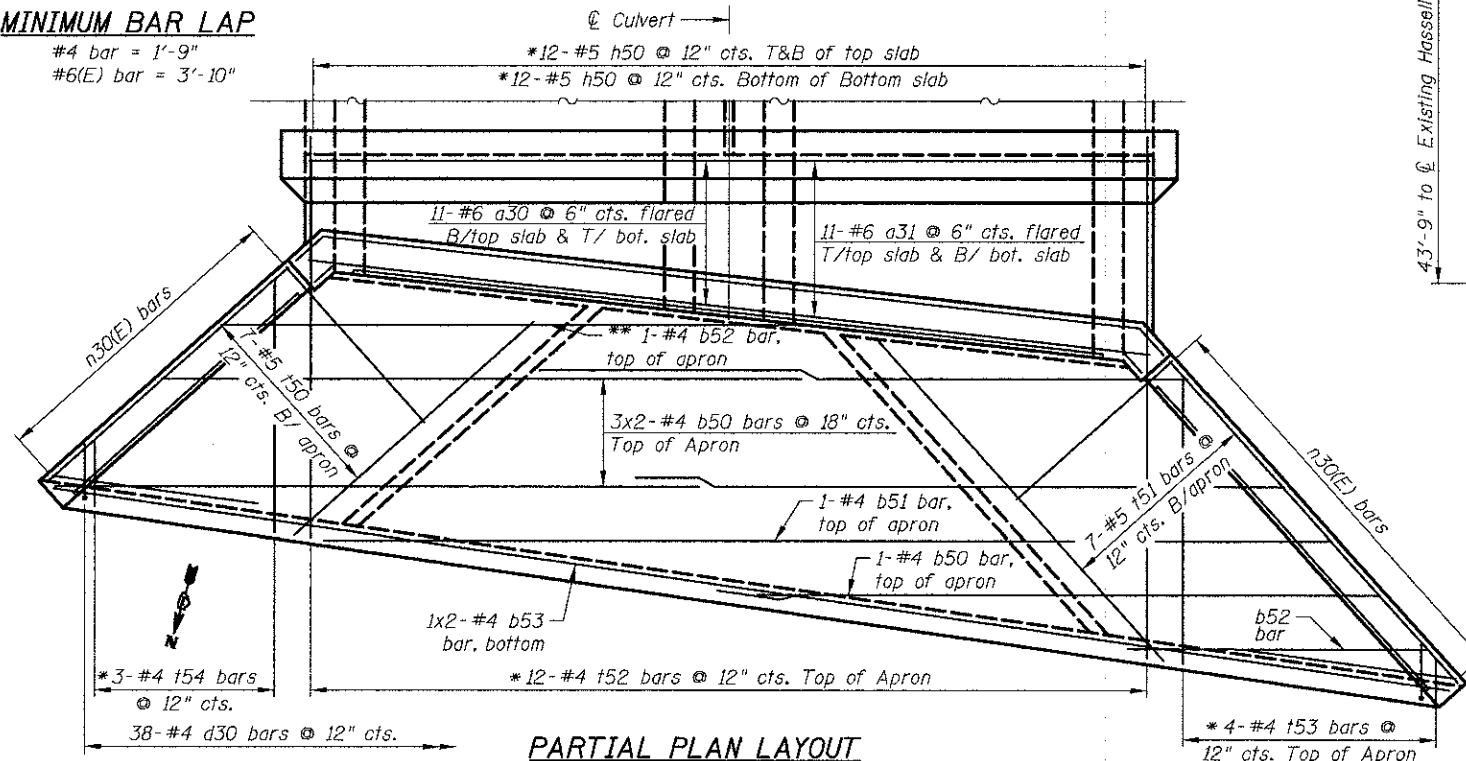

PARTIAL PLAN LAYOUT

Showing reinforcement (North End Section)

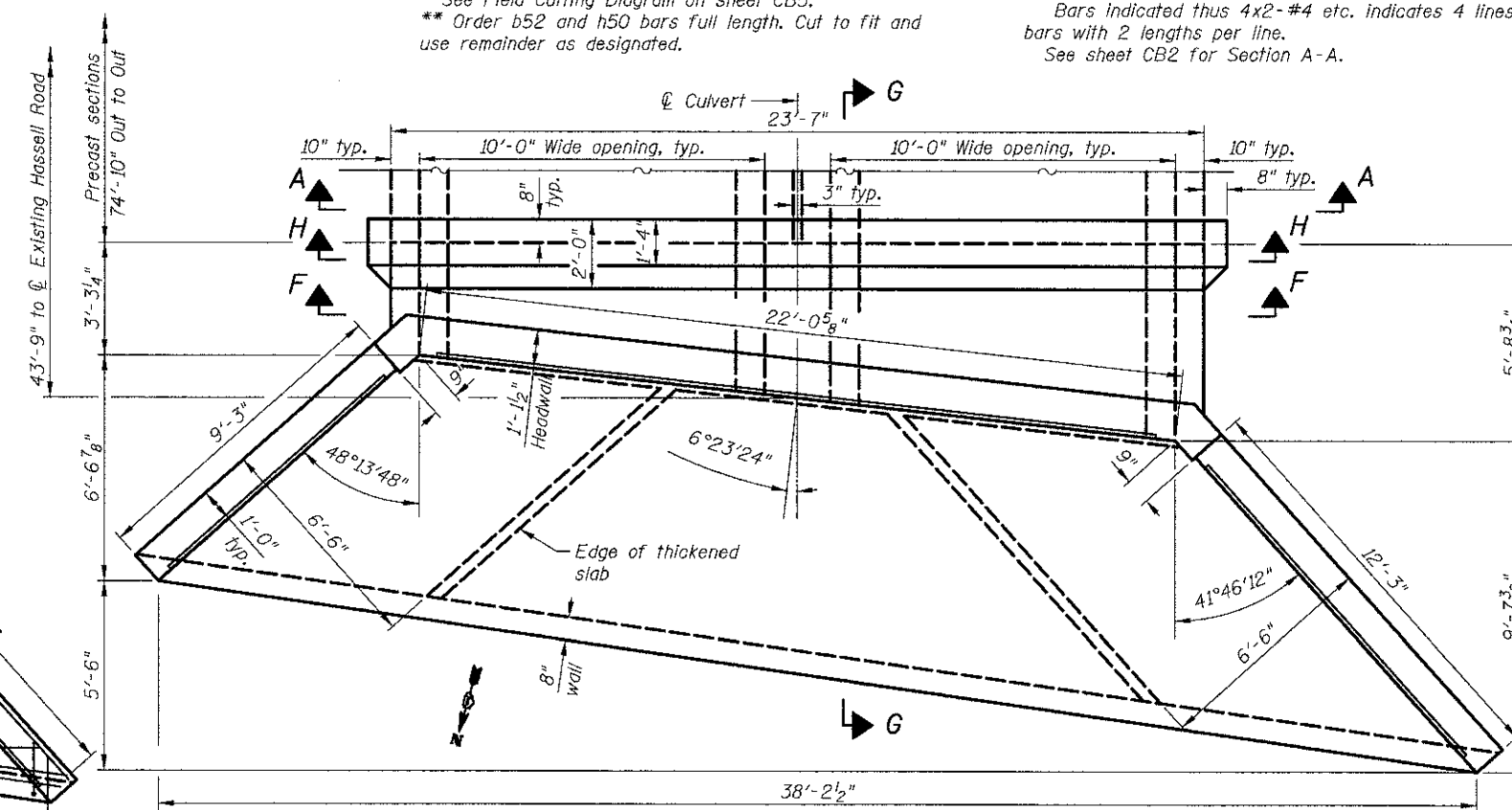

PARTIAL PLAN LAYOUT

Showing Dimension (North End Section)

J:\244\road\06-6344\04_End Section 2.north.plt.dgn
R:3:54 AM
12/12/2012

CIVILTECH
450 E Devon Ave, Suite 300
Itasca, Illinois 60143
Tel: 630.773.3900 Fax: 630.773.3975
www.civiltechinc.com

DRAWN	- M. LANGE	REVISED	-
DESIGNED	- D. ATKINS	REVISED	-
CHECKED	- G. HATLESTAD	REVISED	-
DATE	- DECEMBER 17, 2012	REVISED	-

STATE OF ILLINOIS
DEPARTMENT OF TRANSPORTATION

NORTH END SECTION
HASSELL ROAD OVER POPLAR CREEK
STRUCTURE NO. 016-6344

F.A.I. RTE.	SECTION	COUNTY	TOTAL SHEETS	SHEET NO.
1100	11-00087-00-FP	COOK	164	111
CONTRACT NO. 63770				
(ILLINOIS) FED. AID PROJECT CMM 90037571				

SHEET NO. CB4 OF CB7 SHEETS

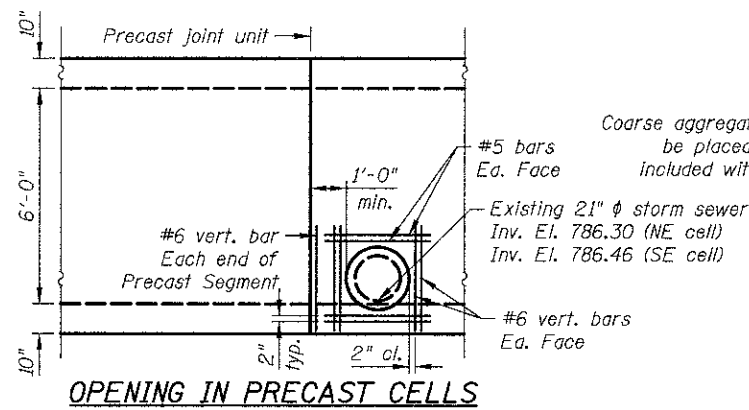

OPENING IN PRECAST CELLS

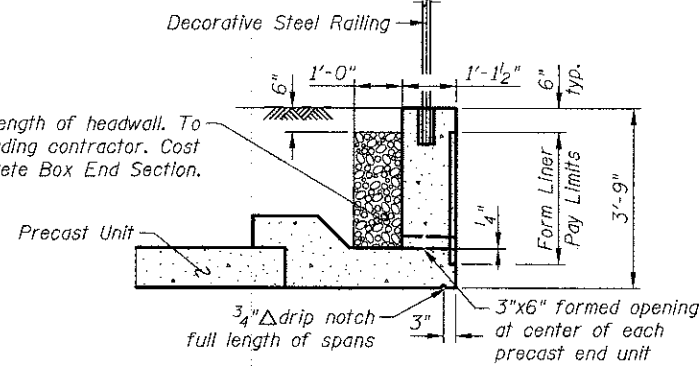

SECTION THRU HEADWALL
(Downstream end)

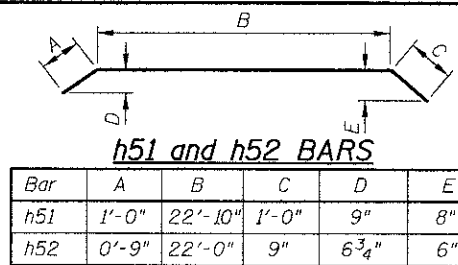

90 DEGREE BEND BARS

Bar	A	B
d30	1'-9"	2'-9"
d50	3'-5"	0'-8"
n30(E)	6'-1"	5'-7"
x31	13'-2"	5'-3"

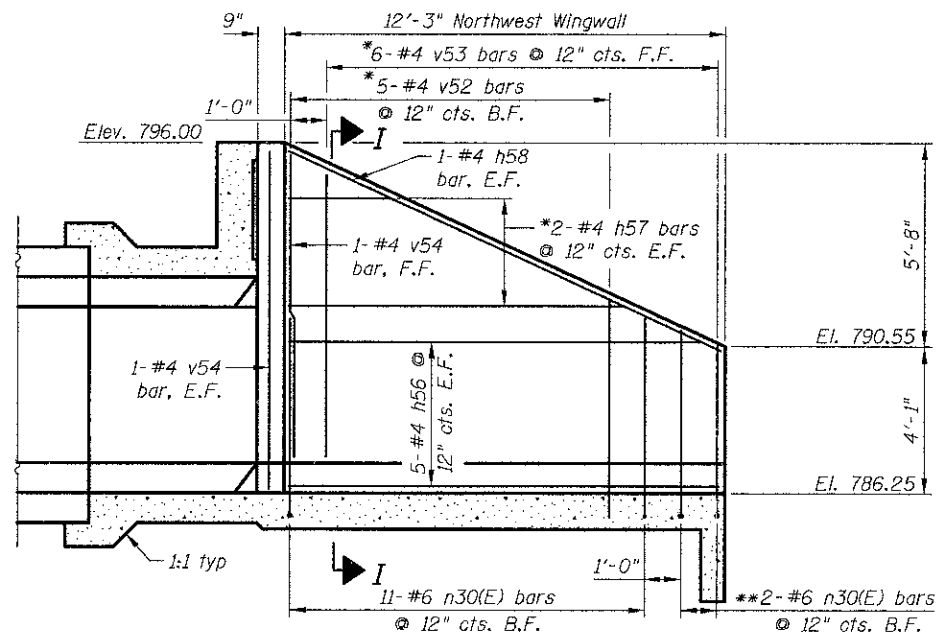

NORTHWEST WINGWALL
(Decorative Steel Railing Not Shown)

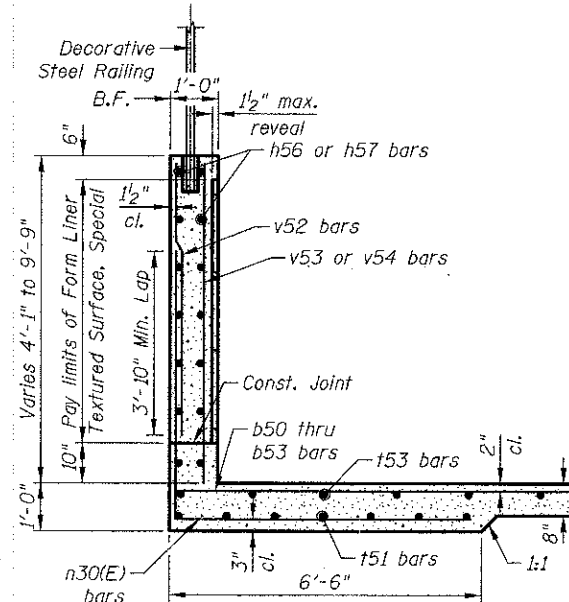

SECTION I-I

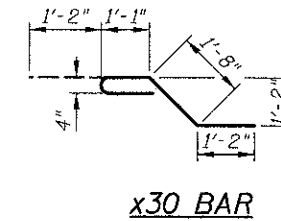

x30 BAR

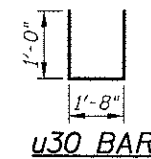

u30 BAR

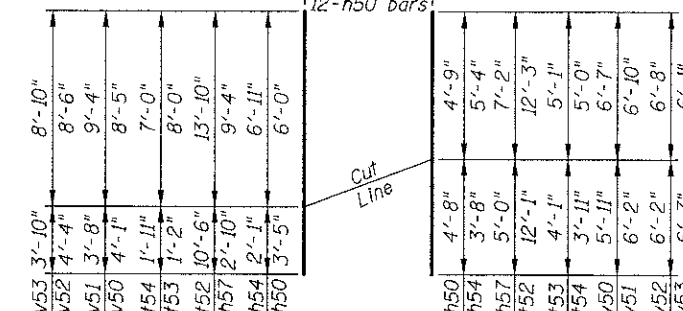

FIELD CUTTING DIAGRAM

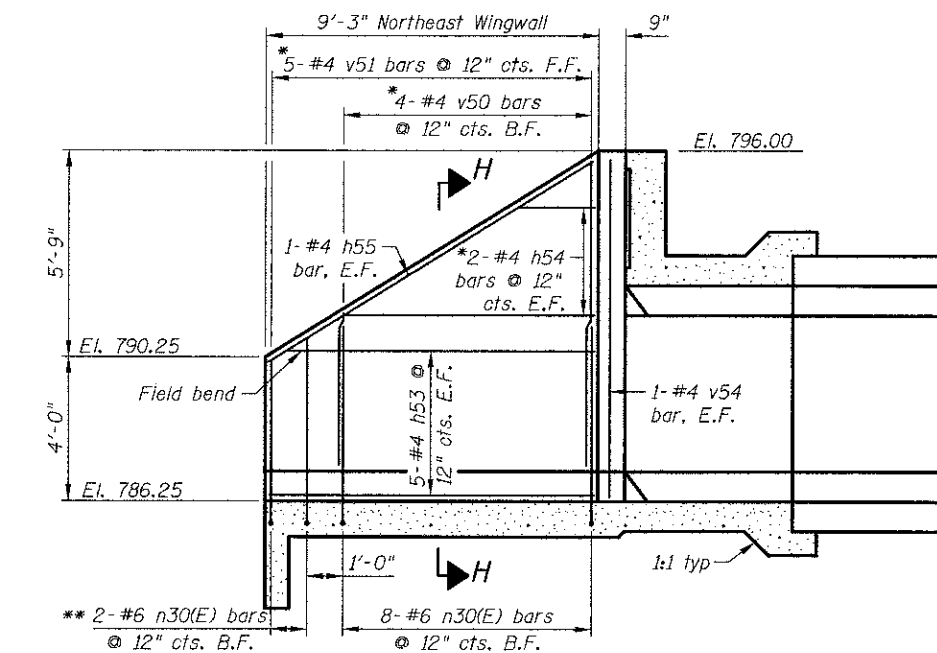

NORTHEAST WINGWALL
(Decorative Steel Railing Not Shown)

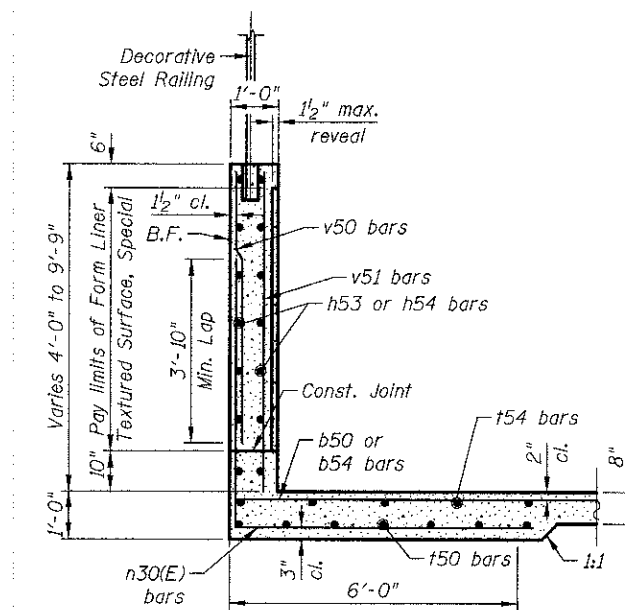

SECTION H-H

h59 THRU h62 BARS

Bar	A	B	C
h59	3'-0"	7"	5 1/4"
h60	2'-5"	7"	5 1/4"
h61	5'-4"	6"	4"
h62	4'-11"	8"	5 3/8"

BILL OF MATERIAL

Item	Unit	Quantity
Box Culvert End Section, Culvert No. 1	Each	1
Form Liner Textured Surface, Special	Sq. Ft.	166

FOR INFORMATION ONLY

Bar	No.	Size	Length	Shape
a30	22	#6	24'-7"	C
a31	22	#6	23'-3"	
b50	7	#4	18'-0"	
b51	1	#4	27'-9"	
b52	1	#4	25'-7"	
b53	2	#4	20'-5"	
d30	38	#4	4'-6"	L
d50	24	#5	4'-1"	L
h50	43	#5	8'-1"	
h51	3	#4	24'-10"	
h52	3	#4	23'-6"	
h53	10	#4	8'-11"	
h54	4	#4	9'-0"	
h55	2	#4	10'-6"	
h56	8	#4	11'-11"	
h57	4	#4	12'-2"	
h58	2	#4	13'-2"	
h59	7	#5	3'-7"	
h60	7	#5	3'-0"	
h61	7	#5	6'-1"	
h62	7	#5	5'-7"	
n30(E)	23	#6	11'-8"	
t50	7	#5	8'-11"	
t51	7	#5	11'-11"	
t52	12	#4	24'-4"	
t53	4	#4	9'-2"	
t54	3	#4	8'-11"	
u30	7	#4	3'-8"	U
v35	34	#5	7'-4"	
v50	4	#4	12'-6"	
v51	5	#4	13'-0"	
v52	5	#4	12'-10"	
v53	6	#4	12'-8"	
v54	5	#4	9'-4"	
v55	24	#4	3'-5"	
x30	70	#4	5'-1"	
x31	12	#4	18'-5"	

Notes:
Quantity of concrete structures and reinforcement bars is shown for information only. The cost is included in Box Culvert End Section, Culvert No. 1.
* See Field Cutting Diagram
** Cut to fit as required

Item	Unit	Quantity
Concrete Structures	Cu. Yd.	33.1
Reinforcement Bars	Pound	4,060
Reinforcement Bars, Epoxy Coated	Pound	410

J:\244\road\016-634\05_End Section 2_Details_north.dgn
 11/3/15 AM
 2/2/2012

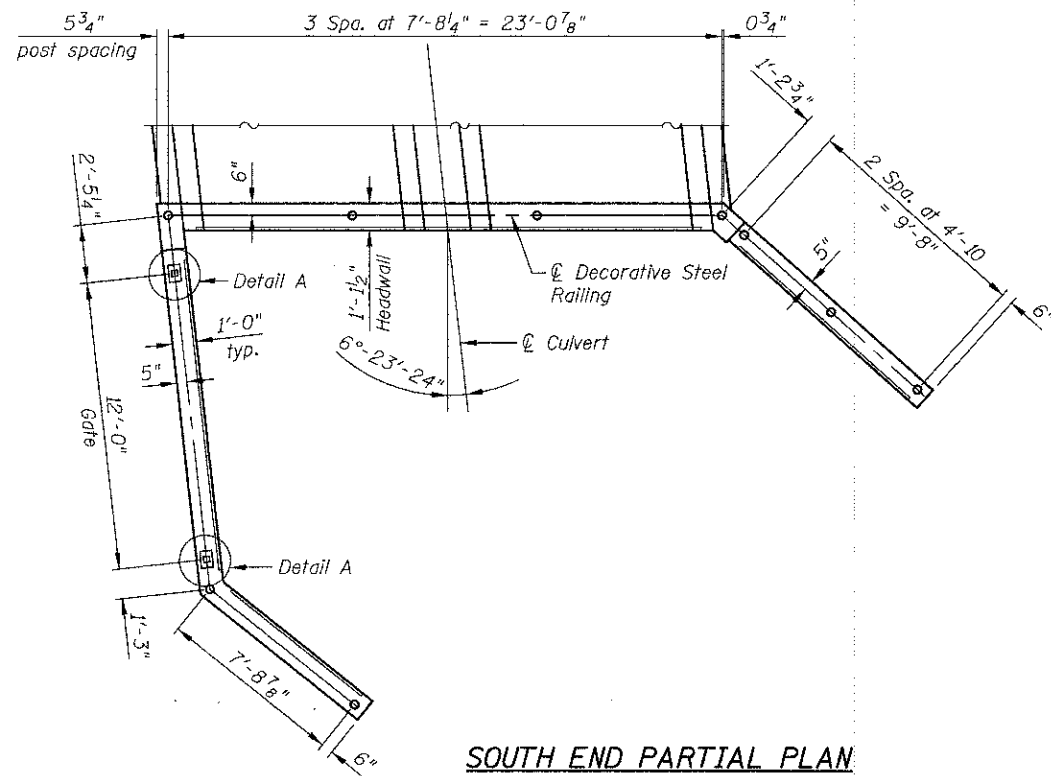

SOUTH END PARTIAL PLAN

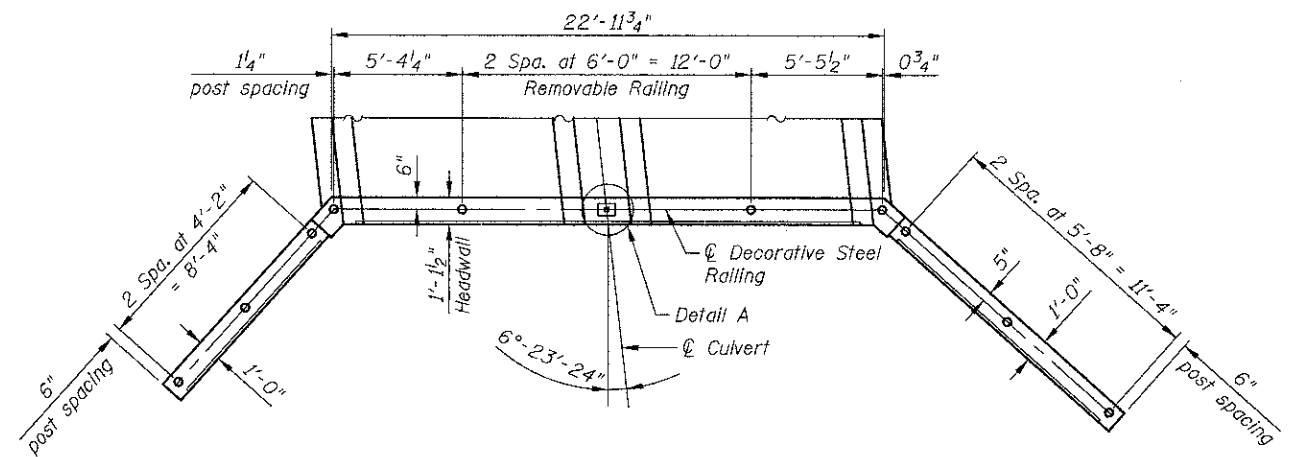

NORTH END PARTIAL PLAN

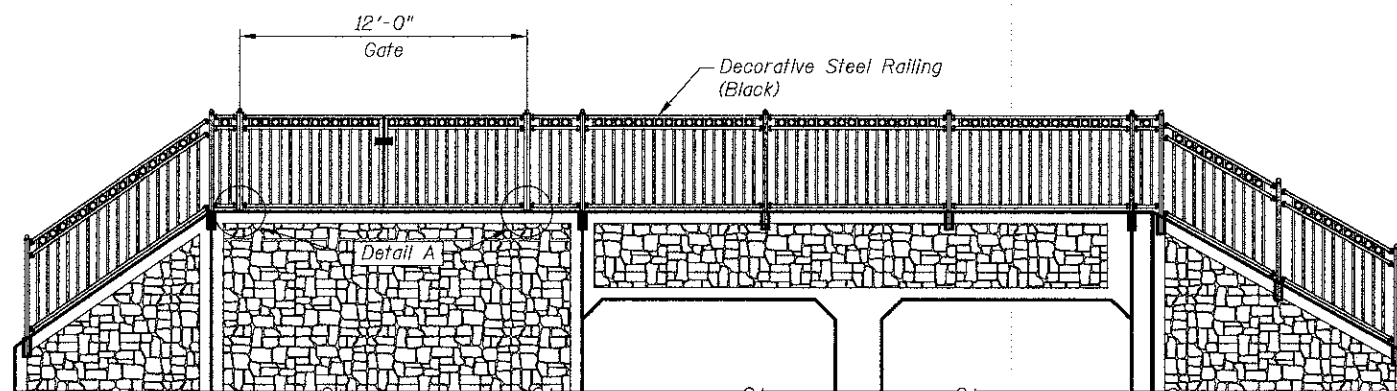

SOUTH END VIEW - UNFOLDED ELEVATION

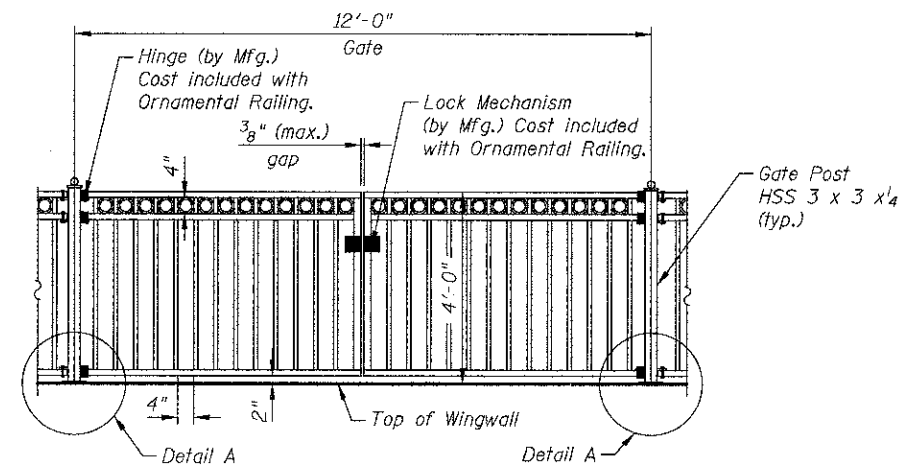

GATE ELEVATION

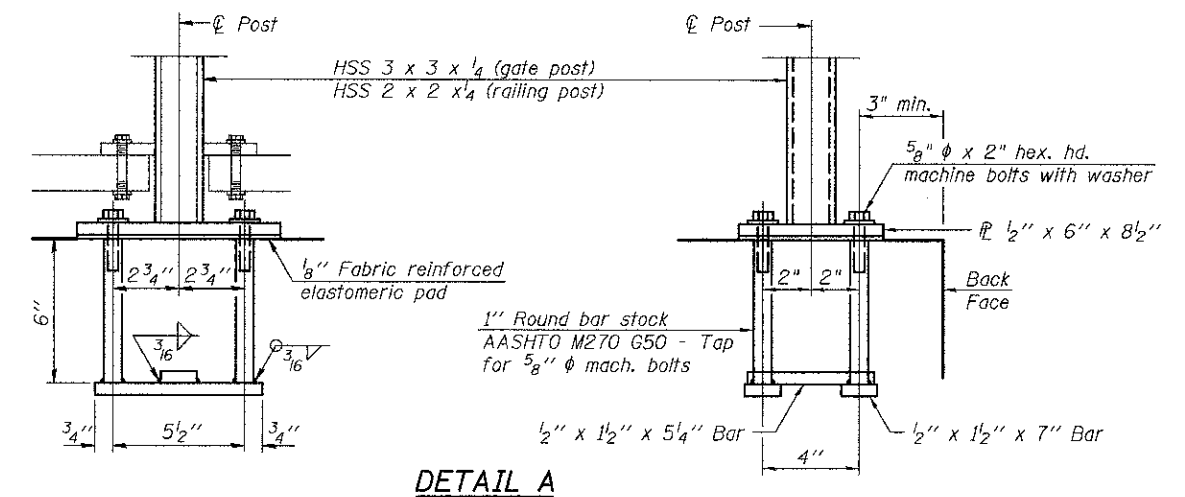

DETAIL A

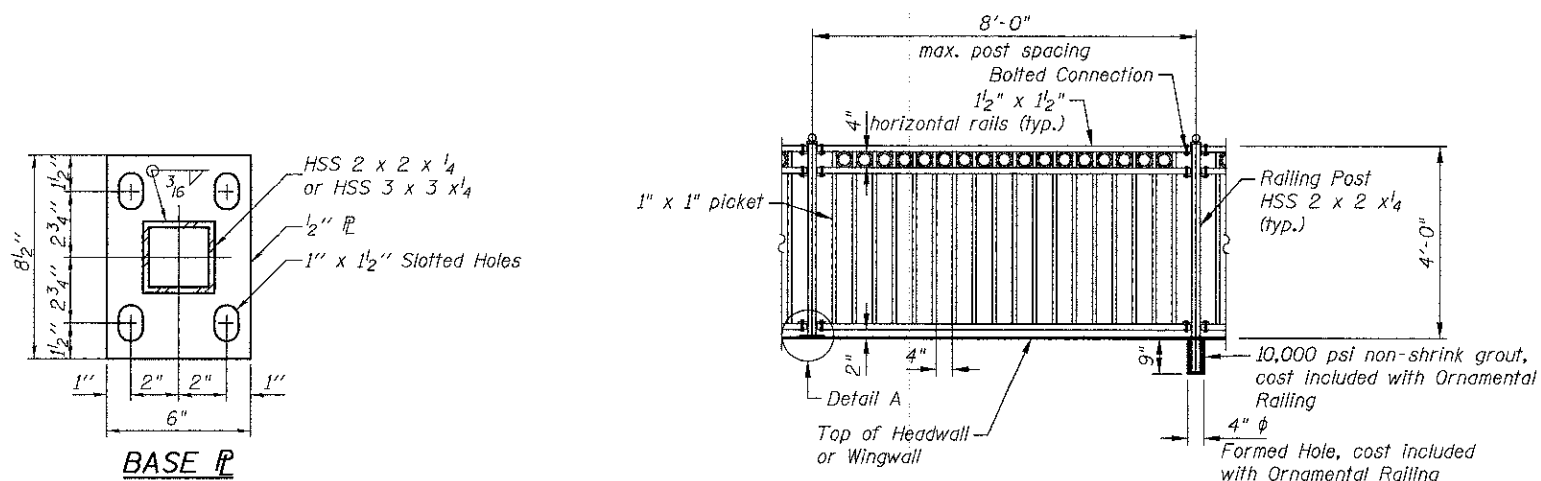

TYPICAL RAILING ELEVATION

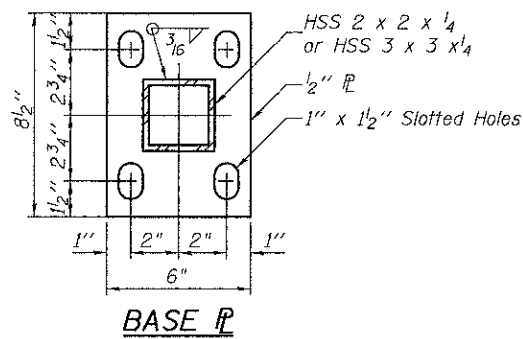

BASE P

BILL OF MATERIAL

Item	Unit	Quantity
Decorative Steel Railing	Foot	103

12/17/2012 10:51:59 AM J:\241\cadd\016-634\A\06_Railing_De tails.dgn



450 E Devon Ave, Suite 300
 Itasca, Illinois 60143
 Tel: 630.773.3900 Fax: 630.773.3975
 www.civiltechinc.com

DRAWN - M. LANGE
 DESIGNED - D. ATKINS
 CHECKED - G. HATLESTAD
 DATE - DECEMBER 17, 2012
 REVISED -
 REVISED -
 REVISED -
 REVISED -

STATE OF ILLINOIS
 DEPARTMENT OF TRANSPORTATION

DECORATIVE STEEL RAILING DETAILS
 HASSELL ROAD OVER POPLAR CREEK
 STRUCTURE NO. 016-6344

SHEET NO. CB6 OF CB7 SHEETS

F.A.L.L. RTE.	SECTION	COUNTY	TOTAL SHEETS	SHEET NO.
1100	11-00087-00-FP	COOK	164	113
				CONTRACT NO. 63770
				ILLINOIS FED. AID PROJECT CMM 6003(757)

MSET PROJECT NO.: 10452		LOG OF BORING NO. B-3		Page 1 of 1						
PROJECT: Hassel Road Culvert Replacement			SITE LOCATION: Hoffman Estates, IL							
BORING LOCATION: STA 60+75, 30' N of CL			CLIENT: Hey & Associates							
DEPTH (feet)	SOIL TYPE	Material Description	Elevation	SAMPLE		TESTS		REMARKS		
				TYPE/INTERVAL	NO.	N-VALUE Blows per ft.	Wc%		Dry Unit Weight, pcf	Unconfined Compressive Strength, tsf
0		Black and Brown Silty CLAY, little to some Sand and Gravel: fill, hard	795.4	SS	1	16	12	-	4.0 (p)	
5		Yellow-Brown and Grey Crushed Gravel, little Clay: fill, slightly dense	792.4	SS	2	8	7	-	-	
		Gravel and Clay Mixed		SS	3	4	11	-	-	
10		Grey SAND (f-c), trace Gravel (SP), medium dense	785.9	SS	4	8	17	-	-	
				SS	5	14	15	-	-	
15		Grey Silty CLAY, trace Sand and Gravel (CL), stiff to hard	781.9	SS	6	9	12	129	1.63	
				SS	7	19	19	111	4.86	
20				SS	8	18	18	113	3.10	
25				SS	9	13	17	107	1.94	
30		End of Boring @ 30'	765.4	SS	10	17	20	111	2.41	

WATER LEVEL OBSERVATIONS, ft.
 DURING DRILLING: 9.0'
 IMMEDIATELY AFTER DRILLING: 9.0'
 DELAYED READING AFTER



BORING STARTED: 12/10/10
 BORING COMPLETED: 12/10/10
 LOGGED BY: SPE
 BORING METHOD: CFA

MSET PROJECT NO.: 10452		LOG OF BORING NO. B-4		Page 1 of 1						
PROJECT: Hassel Road Culvert Replacement			SITE LOCATION: Hoffman Estates, IL							
BORING LOCATION: STA 60+30, 40' S of CL			CLIENT: Hey & Associates							
DEPTH (feet)	SOIL TYPE	Material Description	Elevation	SAMPLE		TESTS		REMARKS		
				TYPE/INTERVAL	NO.	N-VALUE Blows per ft.	Wc%		Dry Unit Weight, pcf	Unconfined Compressive Strength, tsf
0		Brown and Dark Brown Silty CLAY, little to some Sand and Gravel: fill, firm to stiff	796.1	SS	1	5	9	-	1.0 (p)	
5				SS	2	5	16	-	0.5 (p)	
				SS	3	5	14	116	0.70	
10		Black CLAY Topsoil, some Sand, soft	788.1	SS	4	1	25	100	0.39	
				SS	5	2	23	-	-	
15		Brown and Grey Clayey SILT, little Sand, trace Gravel (ML-CL), very stiff	783.1	SS	6	5	21	-	-	
				SS	7	50/2"	23	103	3.03	
20		Grey Silty CLAY, little Sand, trace Gravel (CL), very stiff	777.6	SS	8	15	14	115	2.17	
25				SS	9	12	19	110	2.95	
30		End of Boring @ 30'	766.1	SS	10	18	22	106	3.03	Hole Caved @ 13.8' upon completion

WATER LEVEL OBSERVATIONS, ft.
 DURING DRILLING: 10.5'
 IMMEDIATELY AFTER DRILLING: 9.8'
 DELAYED READING AFTER



BORING STARTED: 12/10/10
 BORING COMPLETED: 12/10/10
 LOGGED BY: SPE
 BORING METHOD: CFA

J:\2441\cod\016-6344\07_Boring_Logs.dgn 11/30/12 AM

Benchmark: Chiseled cross on north sidewalk approximately 1 ft north of curb at Elev. 794.37 feet.
Datum = NGVD29

Existing Structure: SN 016-6326 built in 1970 as twin CMP Pipe Arches, approximate out-to-out width of 25'-10" and approximately 50'-6" in length. No salvage.

Traffic: Traffic will be detoured during construction.

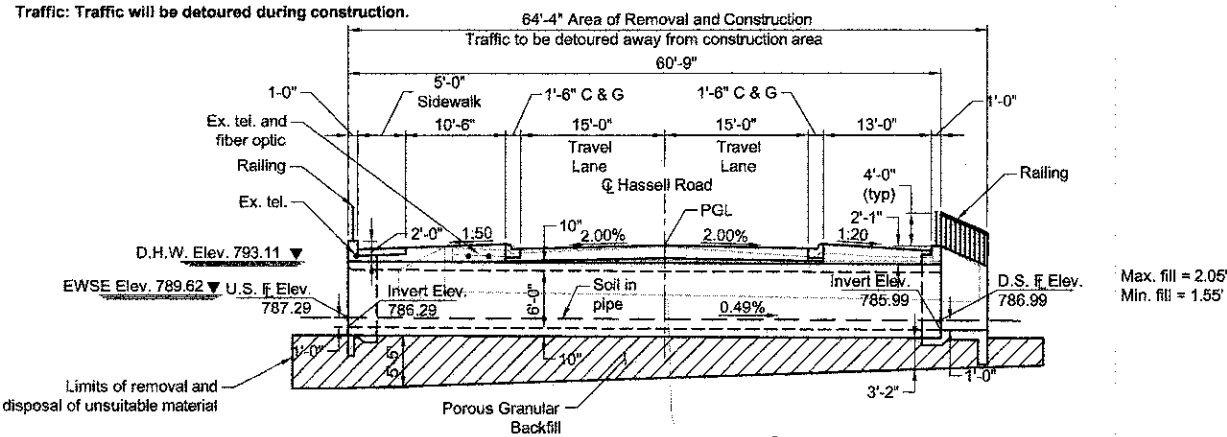

Longitudinal Section

Note: Approx. 3 to 5 feet of undercut of unsuitable soils and replacement with PGE prior to culvert installation.
Dimensions at right angles to Centerline of Roadway unless otherwise noted.

General Notes

1. Precast concrete box culvert sections shall conform to the requirements of ASTM C15577.
2. Lifting holes shall be filled with concrete plugs and mastic after the box sections are in place.
3. Diversion of stream flow during the removal of the existing culvert and the construction of the proposed culvert and all required erosion control measures shall be considered as included in concrete box culverts and no additional compensation will be allowed.

Sheet No.

- CC1
- CC2
- CC3
- CC4
- CC5
- CC6
- CC7

Index of Sheets

- | Description |
|-------------------------------------|
| General Plan & Longitudinal Section |
| South End Section |
| South End Section Details |
| North End Section |
| North End Section Details |
| Decorative Steel Railing Details |
| Soil Boring Logs |

Total Bill of Material

ITEM	UNIT	QUANTITY
REMOVAL AND DISPOSAL OF UNSUITABLE MATERIAL	CU YD	387
POROUS GRANULAR BACKFILL	CU YD	469
BRIDGE RAIL REMOVAL	FOOT	74
PIPE CULVERT REMOVAL	FOOT	101
NAME PLATES	EACH	1
BOX CULVERT END SECTIONS, CULVERT NO. 2	EACH	2
PRECAST CONCRETE BOX CULVERTS 10' X 6'	FOOT	107
DECORATIVE STEEL RAILING	FOOT	95
FORM LINER TEXTURED SURFACE, SPECIAL	SQ. FT.	289

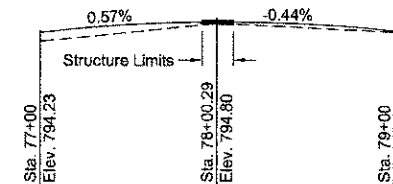

Profile Grade
(along Q roadway)

Waterway Information Table

Flood		Frequency Year	Discharge (cfs)	Waterway Opening (sq. ft.) Existing Proposed	Natural H.W.E.	Created Head (ft.) Existing Proposed	Headwater Elev. Existing Proposed
Design		10	215.00	83.7 98.6	792.45	0.00 0.06	792.45 792.51
		30	270.00	86.2 98.6	793.11	0.01 0.14	793.12 793.25
		50	340.00	86.4 98.6	793.33	0.29 0.17	793.62 793.50
Base (Overtopping)		100	400.00	86.4 98.6	794.04	0.34 0.17	794.38 794.21
Max Calc.		500	555.00	86.4 98.6	794.71	0.11 0.05	794.82 794.76

Drainage Area = 2484.81 acres
3.8825 sq. mi.

Existing Low Grade Elevation = 793.39 ft. @ Sta: 77+60
Proposed Low Grade Elevation = 793.39 ft. @ Sta: 77+60

Range 10E - 3rd PM

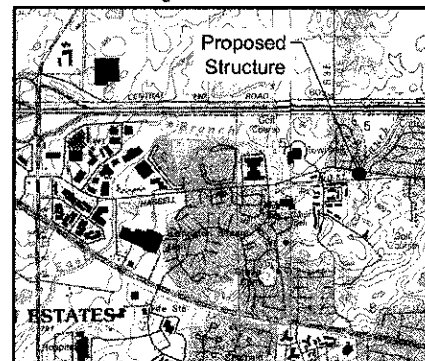

Location Sketch

Loading HL-93
Allow 50#/sq-ft for future wearing surface.
Design Fill Height = 1'-6"

Design Specifications
2012 AASHTO LRFD Bridge
Design Specifications, 6th Edition

Design Stresses
Field Units
f_c = 5,000 psi (pre-cast)
f_y = 60,000 psi (reinforcement)
f_y = 65,000 psi (welded wire fabric)
f_c = 3,500 psi (cast in place)

Station	Offset	Station	Offset
78+13.07	26.55' RT	77+69.66	36.00' LT
78+18.75	32.33' RT	77+90.91	36.00' LT
78+16.04	34.94' RT	77+90.91	34.63' LT
77+82.37	34.94' RT	78+12.18	34.63' LT
77+79.67	32.23' RT	78+12.18	36.00' LT
77+85.47	26.43' RT	78+33.43	36.00' LT
77+87.45	25.00' LT	78+33.43	27.50' LT
77+77.91	25.00' LT	78+25.18	27.50' LT
77+77.91	27.50' LT	78+25.18	25.00' LT
77+69.66	27.50' LT	78+15.05	25.00' LT

Limits of Removal/Disposal

Station 78+00
Built 201_ by
Hoffman Estates
Loading HL-93
Structure No. 016-6343

Name Plate
See Std. 515001

CIVILTECH ENGINEERING, INC.
GREGORY J. HATLESTAD, S.E.

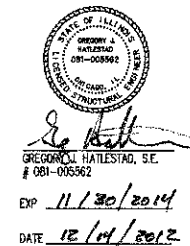

I certify that to the best knowledge, information and belief, this box culvert design is structurally adequate for the design loading shown on the shown plans. The design is an economical one for the style of the structure and complies with the requirements of the current AASHTO LRFD Bridge Design Specifications of Highway Bridges.

General Plan & Longitudinal Section
Hassell Road over
Poplar Creek East Branch
F.A.U. Rt. 1100
Section 11-00087-00-FP
Cook County
Station 78+00.29
Structure No. 016-6343

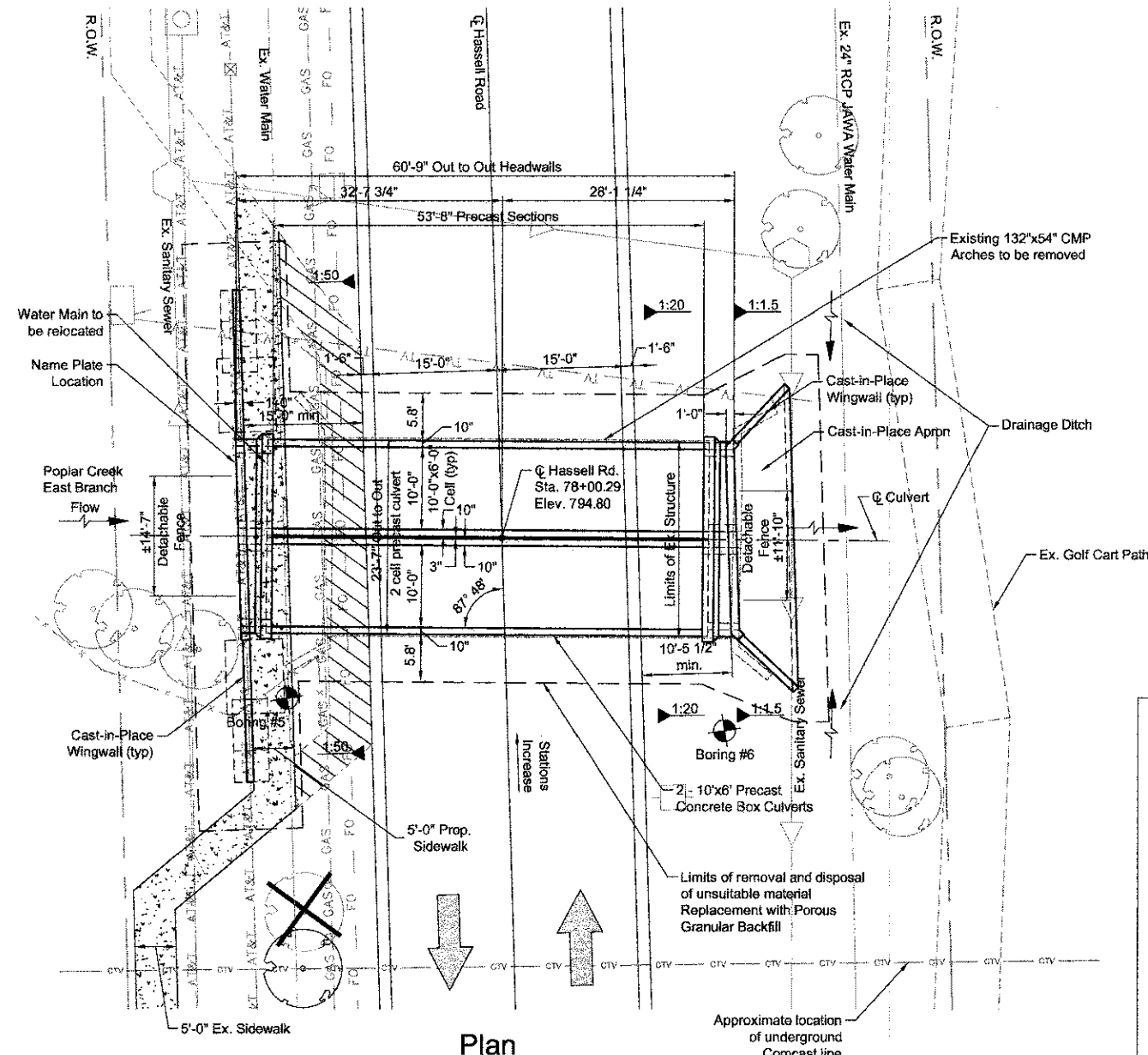

Plan

Note: Dimensions at right angles to Centerline of Roadway unless otherwise depicted.

PLAN	DATE	BY
REVISED		
NOTED		
NO.		

PROFILE	DATE	BY
REVISED		
NOTED		
NO.		

DESIGNED -	REVISED -
DRAWN -	REVISED -
CHECKED -	REVISED -
DATE -	REVISED -

STATE OF ILLINOIS
DEPARTMENT OF TRANSPORTATION

Hassell Road STP Project
Structure No. 016-6343

SCALE: 1" = 10' SHEET NO. CC1 OF CC7 SHEETS STA. TO STA.

F.A.U. RTE.	SECTION	COUNTY	TOTAL SHEETS	SHEET NO.
1100	11-00087-00-FP	Cook	164	115

CONTRACT NO. 63770
ILLINOIS FED. AID PROJECT CMM 9003(757)

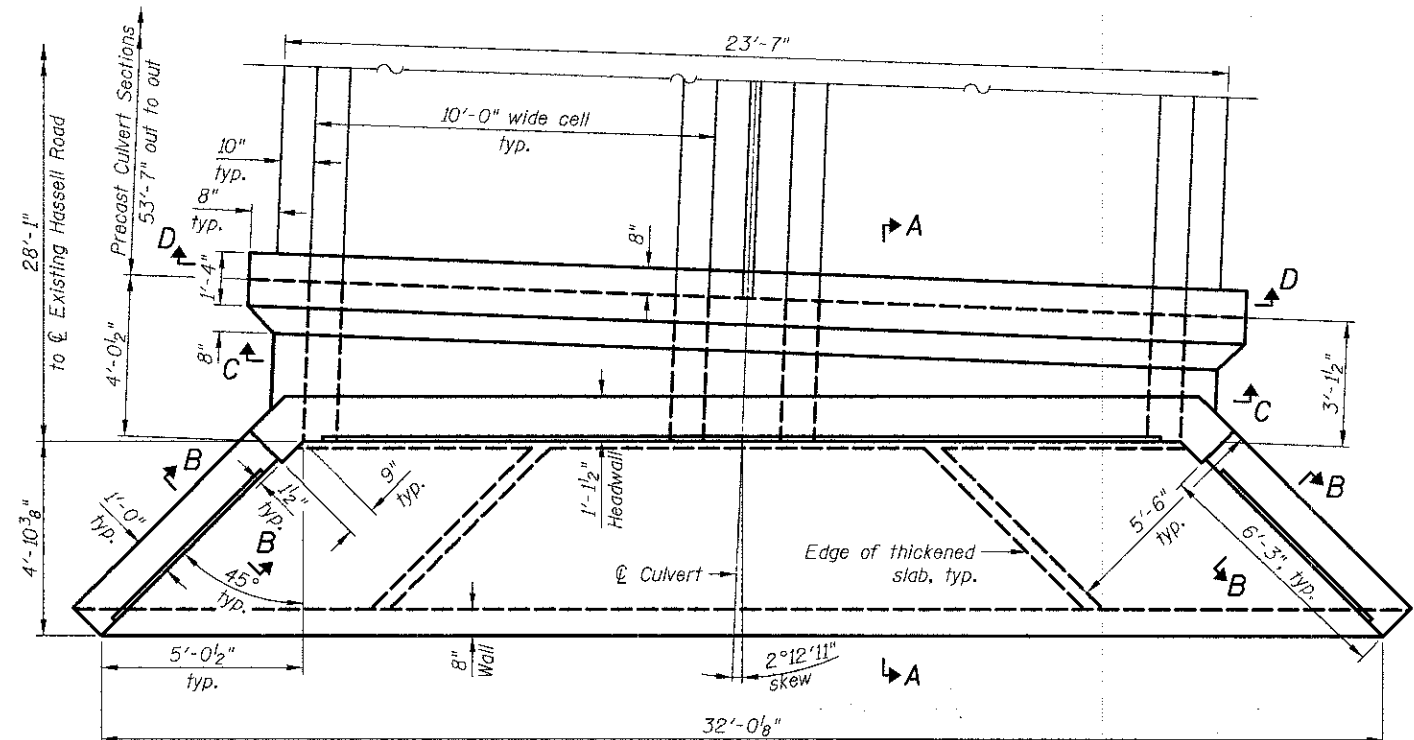

PARTIAL PLAN
(Showing Dimensions)
(South End)

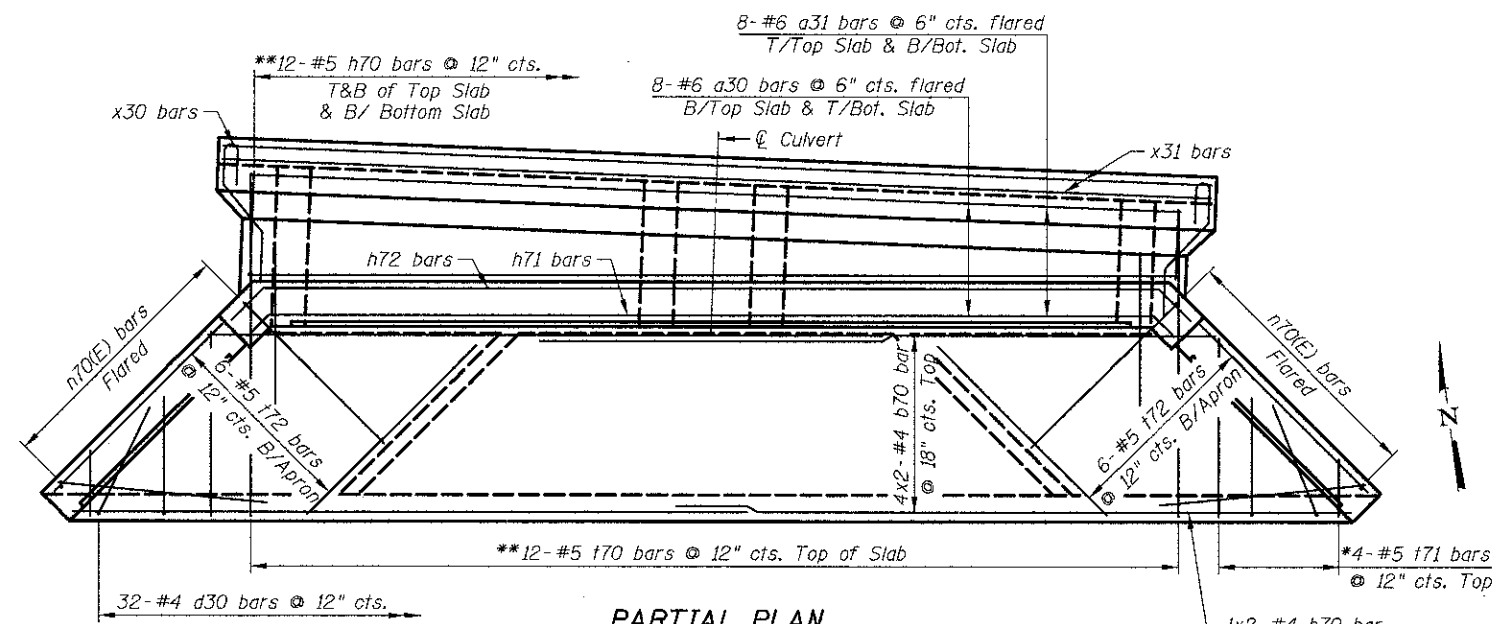

PARTIAL PLAN
(Showing Reinforcement)
(South End)

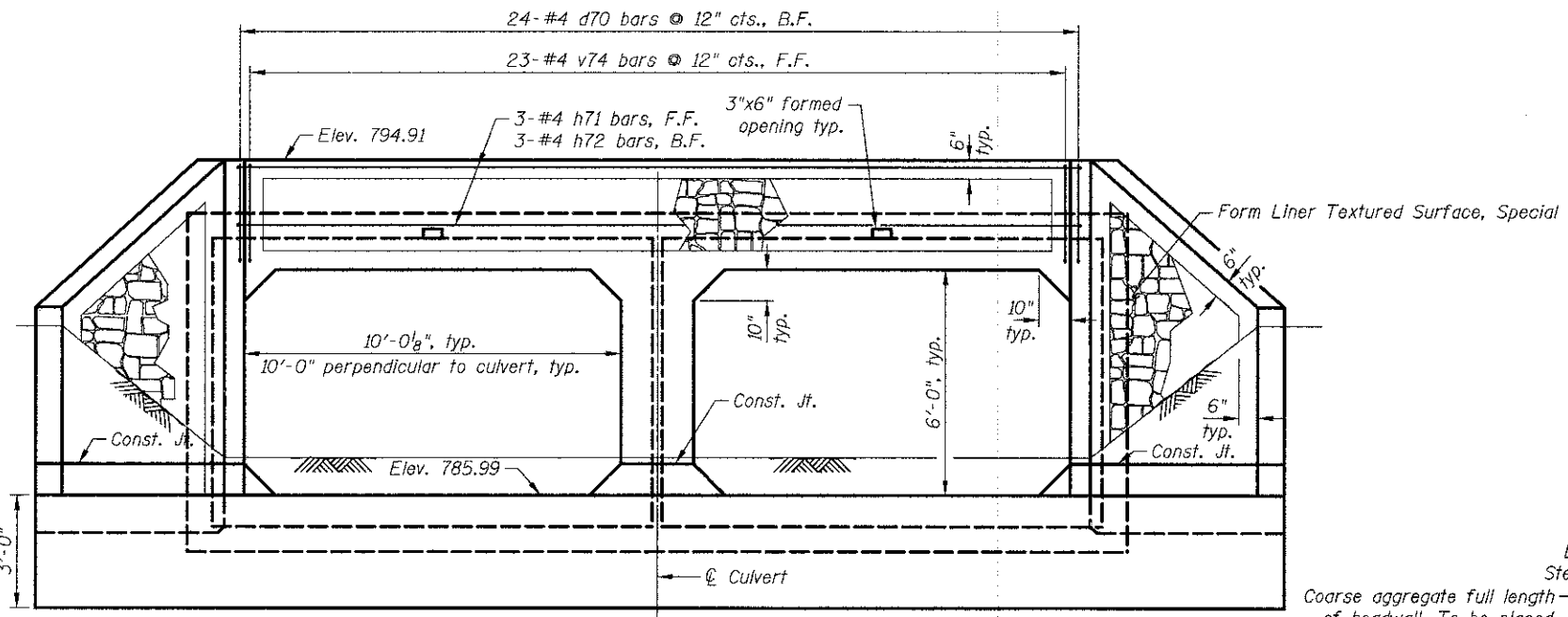

END ELEVATION
(South End)

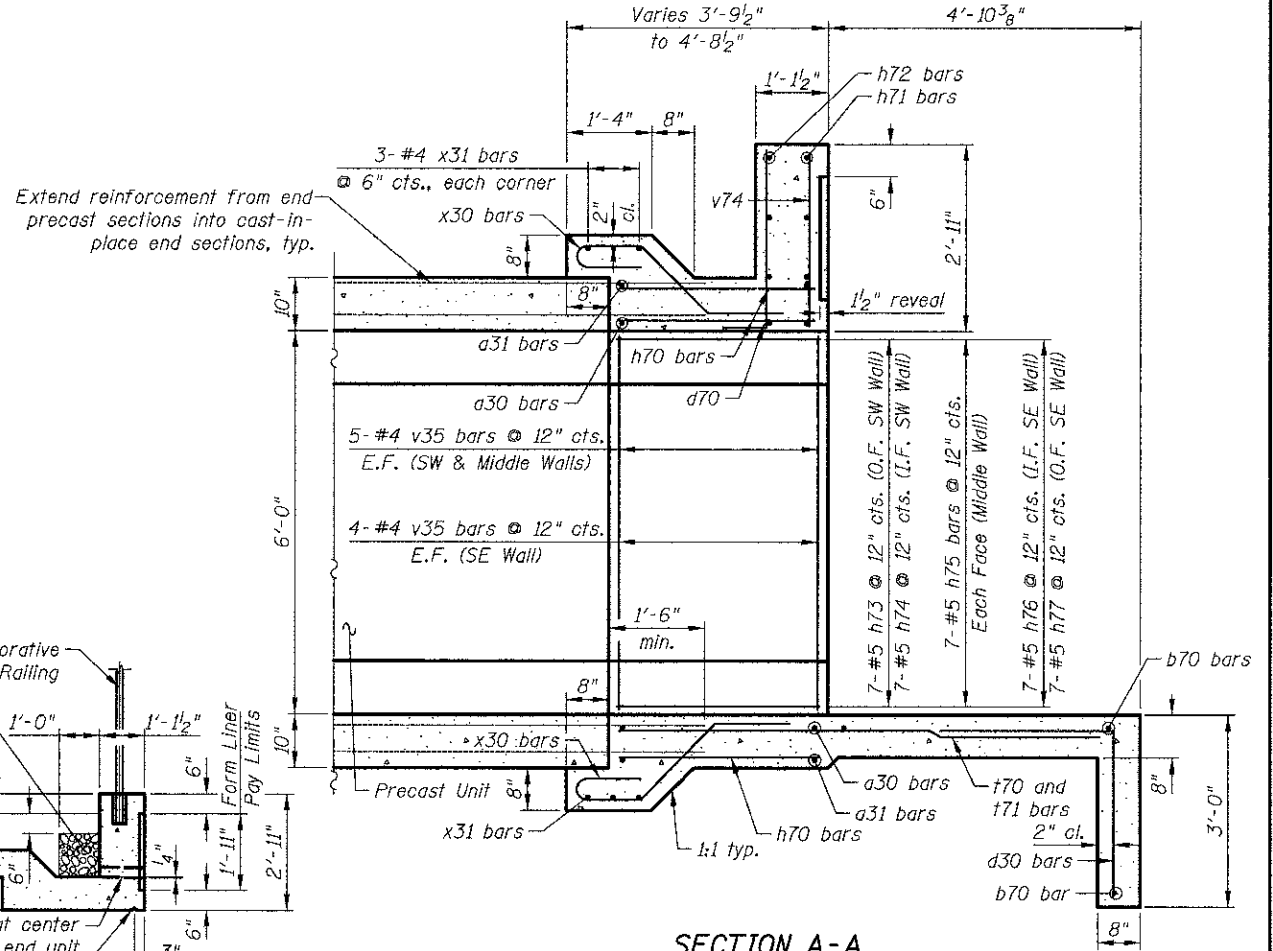

SECTION A-A

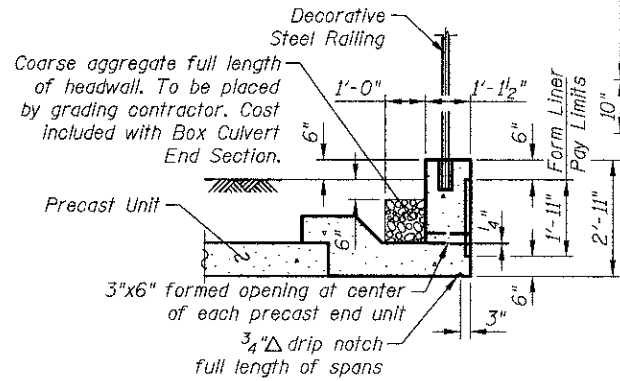

SECTION THRU HEADWALL
(Downstream end)

Notes:
See sheet CC3 for Section B-B, C-C, D-D and Section Thru Precast Box.
Bars indicated thus 4x2-#4 etc. indicates 4 line of bars with 2 lengths per line.

MINIMUM BAR LAP
#4 bar = 1'-9"

* Order bars full length. Cut to fit and use remainder on opposite end.
** See Field Cutting Diagram on sheet CC3.

11/21/2012 11:32:27 AM J:\244\1\road\016-6343\02_S_End_Section.dgn

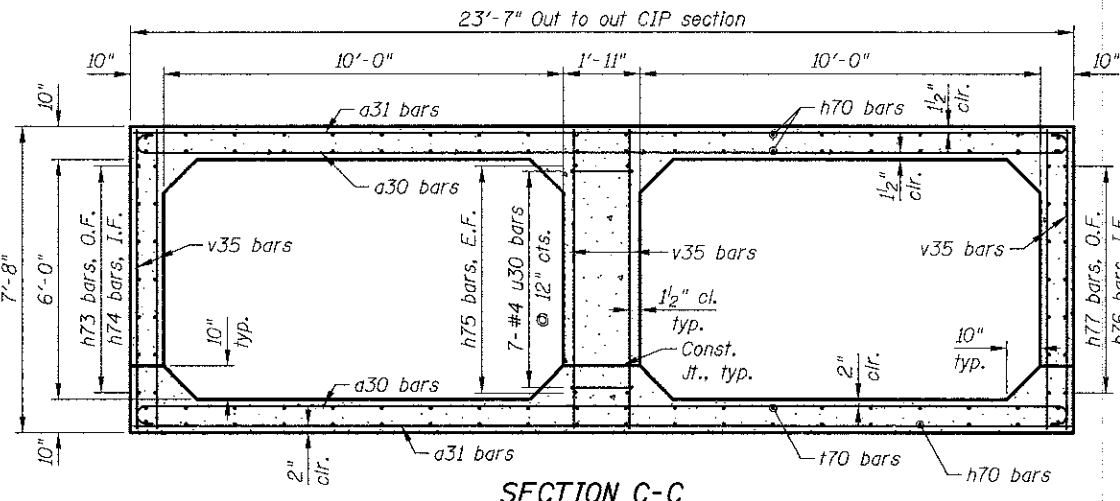

SECTION C-C

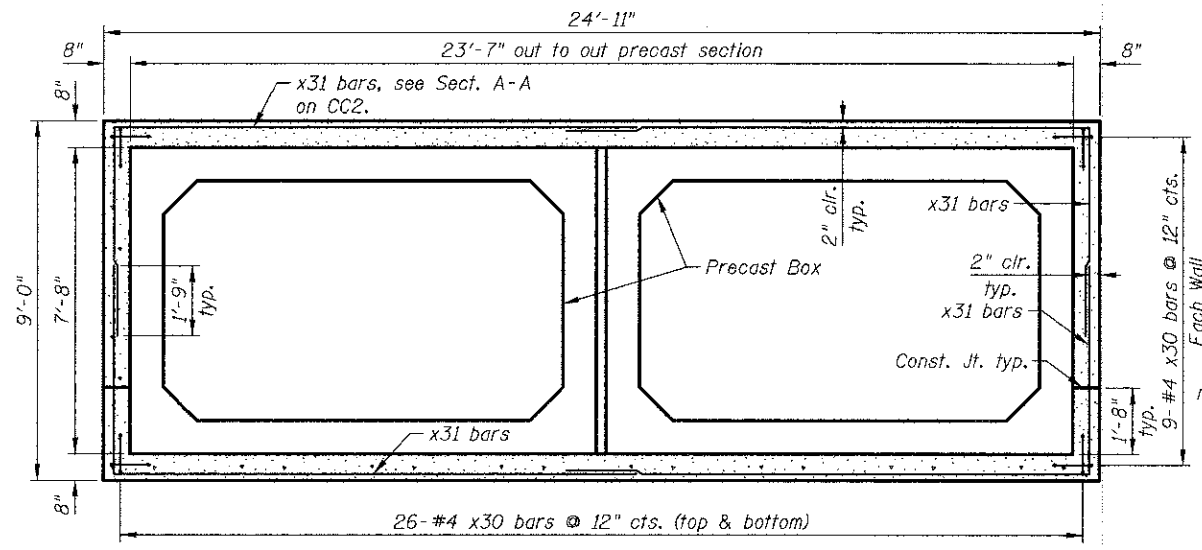

SECTION D-D

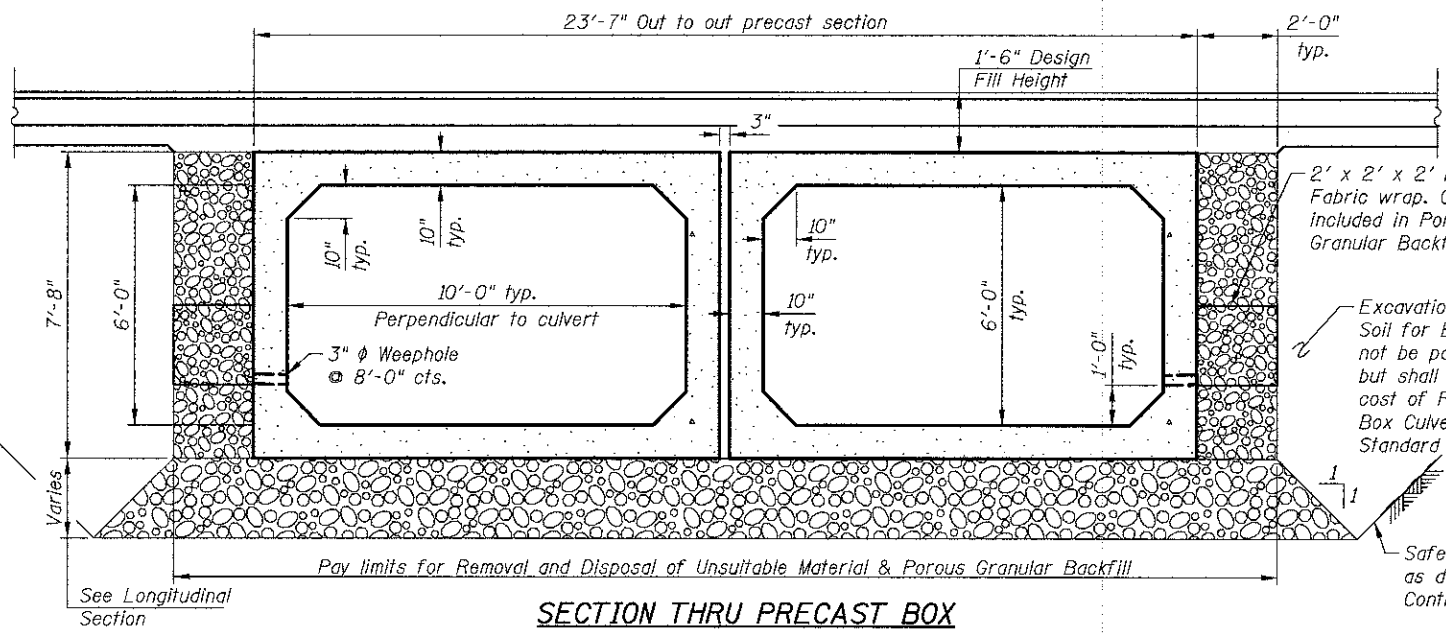

SECTION THRU PRECAST BOX

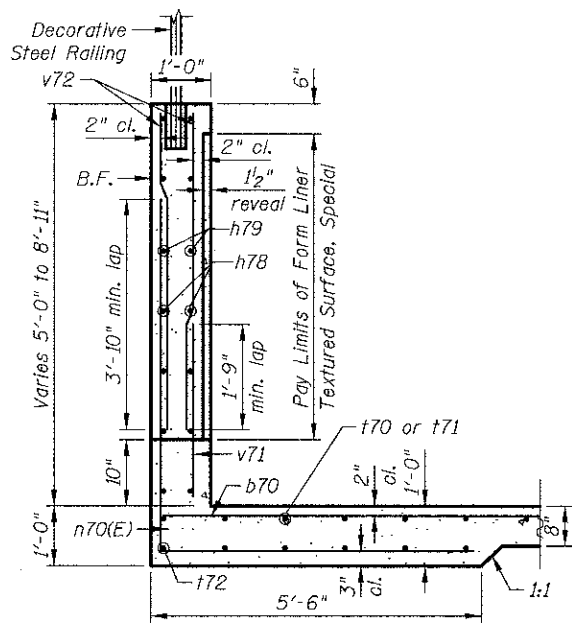

SECTION B-B

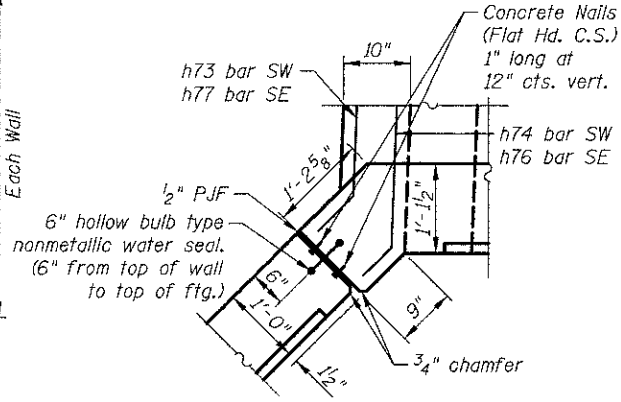

CORNER DETAIL

Water seal and concrete nails are cost included with Concrete Box Culvert End Section

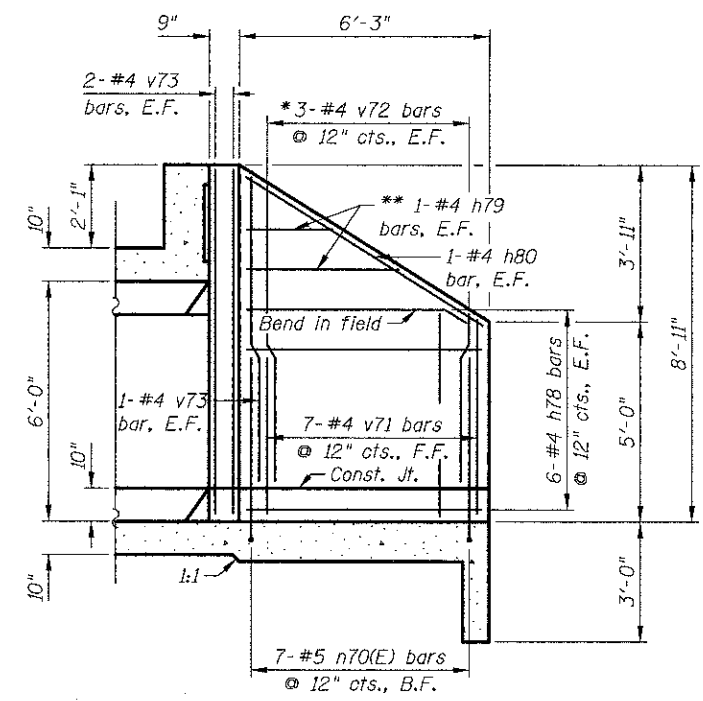

WINGWALL ELEVATION

* See Field Cutting Diagram.
** Order h79 bars full length. Cut and use remainder as designated.

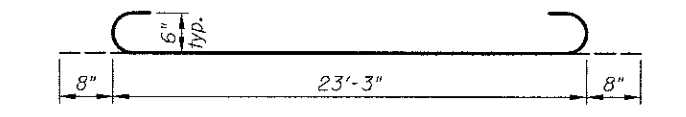

90 DEGREE BEND BARS

Bar	A	B
d30	2'-9"	1'-9"
d70	2'-7"	8"
h70(E)	5'-7"	5'-1"
x31	13'-2"	5'-3"

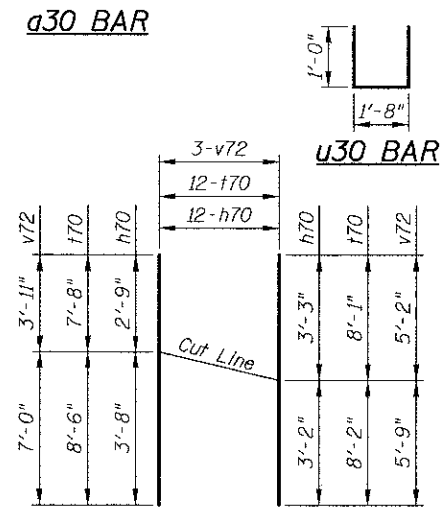

FIELD CUTTING DIAGRAM

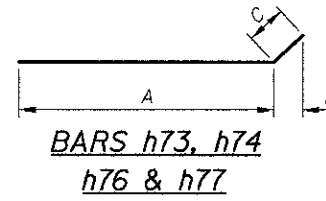

Bar	A	B	C
h73	3'-1"	5' ⁷ / ₈ "	8"
h74	3'-9"	5' ⁶ / ₈ "	7"
h76	2'-11"	4' ³ / ₄ "	7"
h77	2'-4"	4' ³ / ₄ "	7"

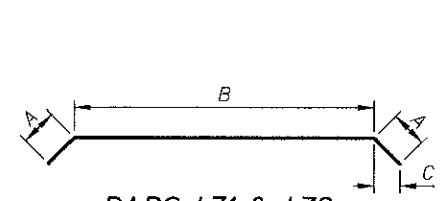

Bar	A	B	C
h71	10"	21'-10"	7' ⁶ / ₈ "
h72	1'-0"	22'-9"	8' ¹ / ₂ "

FOR INFORMATION ONLY

Bar	No.	Size	Length	Shape
a30	16	#6	24'-7"	┌
a31	16	#6	23'-3"	┌
b70	10	#4	16'-11"	┌
d30	32	#4	4'-6"	┌
d70	24	#4	3'-3"	┌
h70	36	#5	6'-5"	┌
h71	3	#4	23'-6"	┌
h72	3	#4	24'-9"	┌
h73	7	#5	3'-9"	┌
h74	7	#5	4'-4"	┌
h75	14	#5	3'-2"	┌
h76	7	#5	3'-6"	┌
h77	7	#5	2'-11"	┌
h78	24	#4	5'-11"	┌
h79	4	#4	6'-3"	┌
h80	4	#4	7'-0"	┌
n70(E)	14	#6	10'-8"	┌
170	12	#5	16'-2"	┌
171	4	#5	6'-2"	┌
172	12	#5	5'-11"	┌
u30	7	#4	3'-8"	┌
v35	28	#4	7'-4"	┌
v71	14	#4	2'-9"	┌
v72	12	#4	10'-11"	┌
v73	12	#4	8'-7"	┌
v74	23	#4	2'-7"	┌
x30	70	#4	5'-1"	┌
x31	12	#4	18'-5"	┌
Item	Unit	Quantity		
Concrete Structures	Cu. Yd.	23.1		
Reinforcement Bars	Pound	3,100		
Reinforcement Bars, Epoxy Coated	Pound	230		

MINIMUM BAR LAP

#4 bar = 1'-9"
#6(E) bar = 3'-10"

Note: Quantity of concrete structures and reinforcement bars is shown for information only. The cost is included in Box Culvert End Section, Culvert No. 2.

BILL OF MATERIAL

Item	Unit	Quantity
Box Culvert End Section, Culvert No. 2	Ea.	1
Form Liner Textured Surface, Special	Sq. Ft.	99

11/30/2012 12:12/2012 J:\2441\wood\016-6343\03.S End Details.dgn

CIVILTECH
450 E Devon Ave, Suite 300
Itasca, Illinois 60143
Tel: 630.773.3900 Fax: 630.773.3975
www.civiltechinc.com

DRAWN - J. SCHROEDER	REVISED -
DESIGNED - D. ATKINS	REVISED -
CHECKED - G. HATLESTAD	REVISED -
DATE - DECEMBER 17, 2012	REVISED -

**STATE OF ILLINOIS
DEPARTMENT OF TRANSPORTATION**

**SOUTH END SECTION DETAILS
HASSELL ROAD OVER POPLAR CREEK
STRUCTURE NO. 016-6343**

F.A.I. RTE.	SECTION	COUNTY	TOTAL SHEETS	SHEET NO.
1100	11-00087-00-FP	COOK	164	117
CONTRACT NO. 63770				
ILLINOIS FED. AID PROJECT CMM 90031(757)				

SHEET NO. CC3 OF CC7 SHEETS

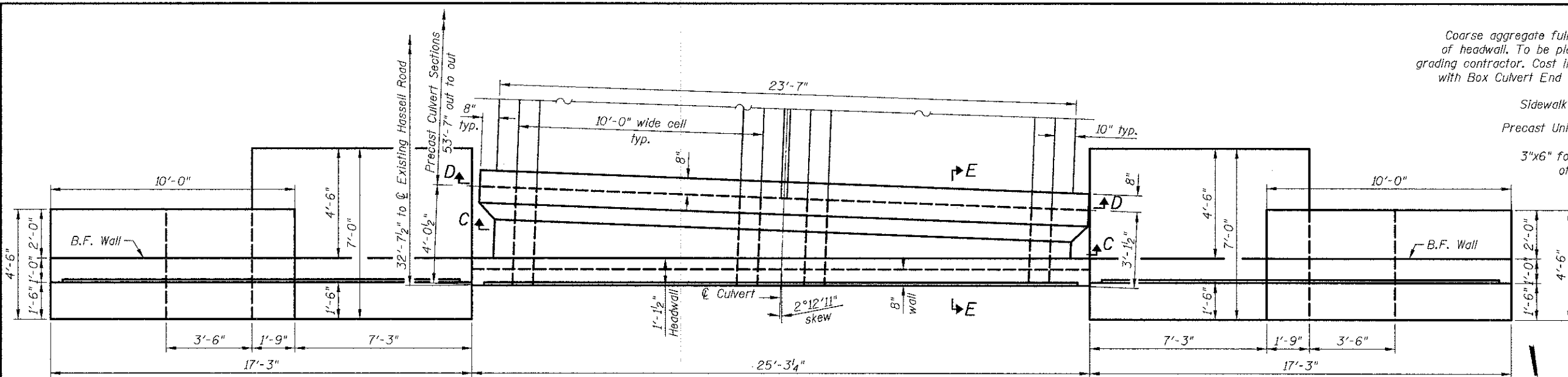

PLAN

(Showing Dimensions)
(North End)

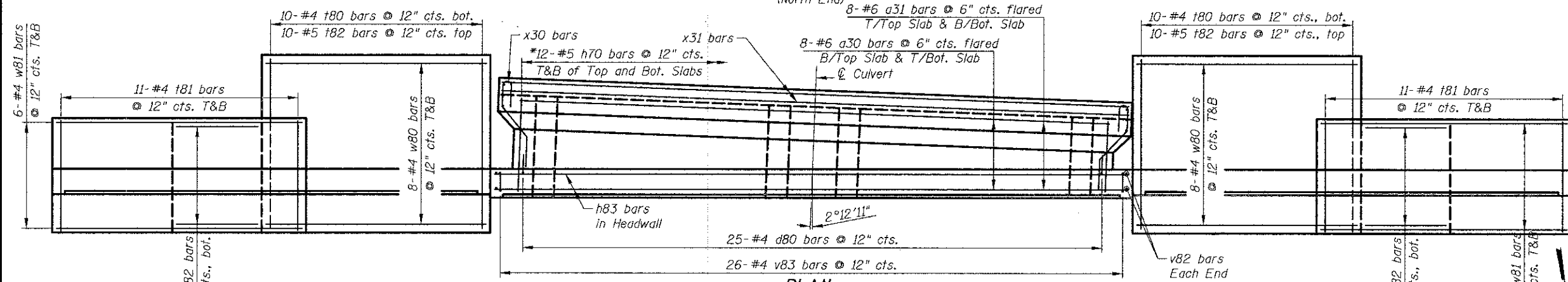

PLAN

(Showing Reinforcement)
(North End)

* See Field Cutting Diagram on sheet CC5
(North End)

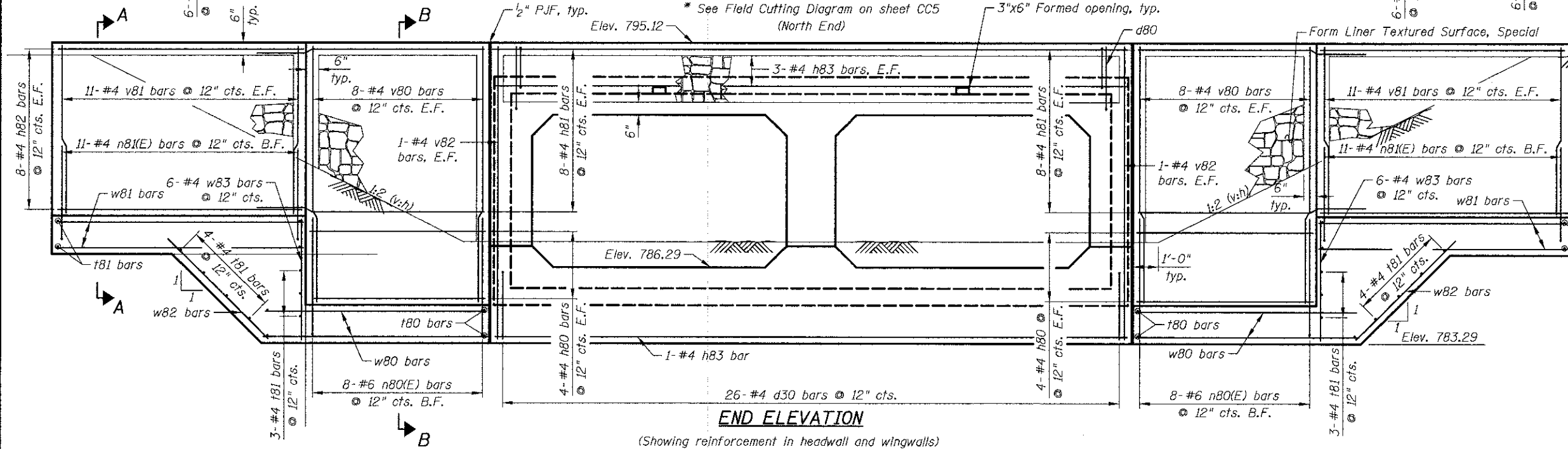

END ELEVATION

(Showing reinforcement in headwall and wingwalls)
(North End)

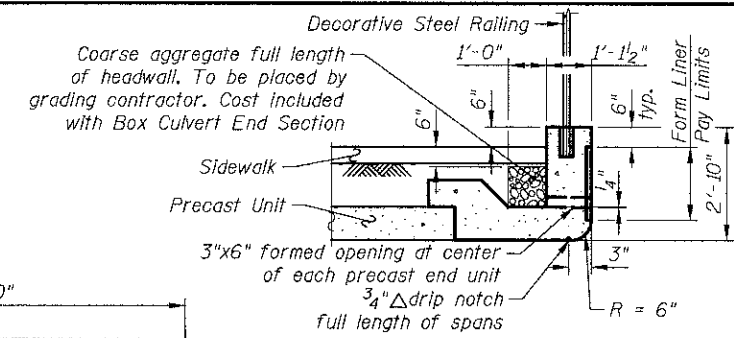

SECTION THRU HEADWALL

(Upstream End)

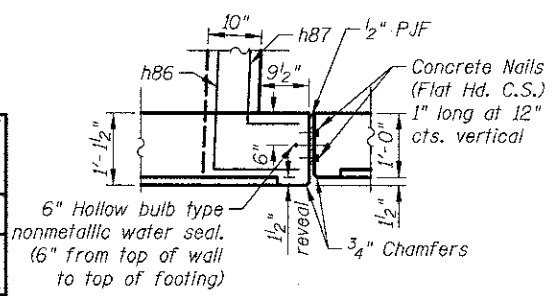

NORTHWEST CORNER DETAIL

Water seal and concrete nails are cost included with Concrete Box Culvert End Section

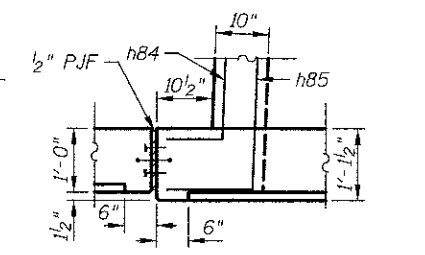

NORTHEAST CORNER DETAIL

See NW corner for balance of information

MINIMUM BAR LAP

- #4 bar = 1'-9"
- #4(E) bar = 2'-7"
- #6(E) bar = 3'-10"

Notes:

See sheet CC5 for Section A-A, B-B, C-C, D-D, & E-E.
See sheet CC3 for Section Thru Precast Box.

12/12/2012 11:32:32 AM J:\2441\cc04\016-6343\04_N End Section.dgn

CIVILTECH
450 E Devon Ave, Suite 300
Itasca, Illinois 60143
Tel: 630.773.3900 Fax: 630.773.3975
www.civiltechinc.com

DRAWN	- J. SCHROEDER	REVISED	-
DESIGNED	- D. ATKINS	REVISED	-
CHECKED	- G. HATLESTAD	REVISED	-
DATE	- DECEMBER 17, 2012	REVISED	-

STATE OF ILLINOIS
DEPARTMENT OF TRANSPORTATION

NORTH END SECTION
HASSELL ROAD OVER POPLAR CREEK
STRUCTURE NO. 016-6343

SHEET NO. CC4 OF CC7 SHEETS

F.A.U. RTE.	SECTION	COUNTY	TOTAL SHEETS	SHEET NO.
1100	11-00087-00-FP	COOK	164	118
CONTRACT NO. 63770				
ILLINOIS FED. AID PROJECT CNM 9003(757)				

FOR INFORMATION ONLY

Bar	No.	Size	Length	Shape
a30	16	#6	24'-7"	U
a31	16	#6	23'-3"	—
d30	26	#4	4'-6"	□
d80	25	#4	3'-2"	□
h70	48	#5	6'-5"	—
h75	14	#5	3'-4"	—
h80	16	#4	7'-0"	—
h81	32	#4	9'-0"	—
h82	32	#4	9'-8"	—
h83	7	#4	24'-11"	—
h84	7	#5	3'-9"	J
h85	7	#5	5'-0"	J
h86	7	#5	4'-1"	L
h87	7	#5	2'-10"	L
n80(E)	16	#6	5'-8"	—
n81(E)	22	#4	3'-9"	—
t80	20	#4	6'-8"	—
t81	58	#4	4'-2"	—
t82	20	#5	6'-8"	—
u30	7	#4	3'-8"	□
v35	28	#4	7'-4"	—
v80	32	#4	10'-0"	—
v81	44	#4	6'-6"	—
v82	4	#4	11'-6"	—
v83	26	#4	2'-5"	—
w80	32	#4	8'-8"	—
w81	24	#4	9'-8"	—
w82	12	#4	5'-3"	—
w83	12	#4	4'-8"	—
x30	70	#4	5'-1"	J
x31	12	#4	18'-5"	J
Item		Unit	Quantity	
Concrete Structures		Cu. Yd.	41.0	
Reinforcement Bars		Pound	4,190	
Reinforcement Bars, Epoxy Coated		Pound	200	

Note:
Quantity of concrete structures and reinforcement bars is shown for information only. The cost is included in Box Culvert End Section, Culvert No. 2.

BILL OF MATERIAL

Item	Unit	Quantity
Porous Granular Backfill	Cu. Yd.	19
Box Culvert End Section, Culvert No. 2	Ea.	1
Form Liner Textured Surface, Special	Sq. Ft.	185

F.A.U. RTE.	SECTION	COUNTY	TOTAL SHEETS	SHEET NO.
1100	11-00087-00-FP	COOK	164	119

CONTRACT NO. 63770
ILLINOIS FED. AID PROJECT CMM 90031757

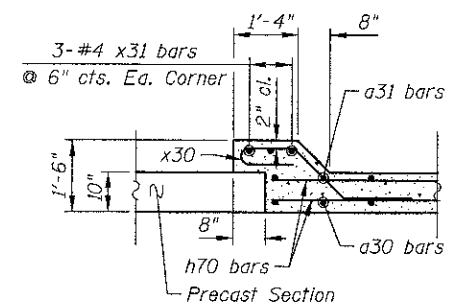

DETAIL "A"

90 DEGREE BEND BARS

Bar	A	B
d30	2'-9"	1'-9"
d80	2'-6"	8"
x31	5'-3"	13'-2"

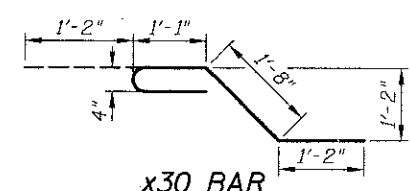

x30 BAR

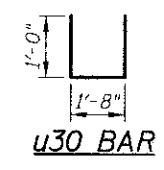

u30 BAR

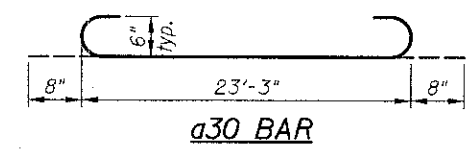

a30 BAR

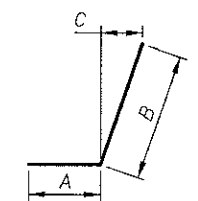

h84 & h85 BARS

Bar	A	B	C
h84	10"	2'-11"	1 ³ / ₈ "
h85	1'-5"	3'-7"	1 ⁵ / ₈ "

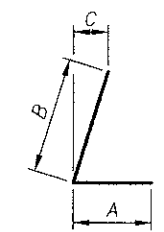

h86 & h87 BARS

Bar	A	B	C
h86	1'-4"	2'-9"	1 ¹ / ₄ "
h87	10"	2'-0"	7 ⁸ / ₁₆ "

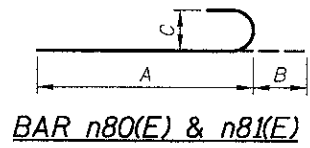

BAR n80(E) & n81(E)

Bar	A	B	C
n80(E)	5'-0"	8"	6"
n81(E)	3'-3"	6"	4"

MINIMUM BAR LAP

#4 bar = 1'-9"
#4(E) bar = 2'-7"
#6(E) bar = 3'-10"

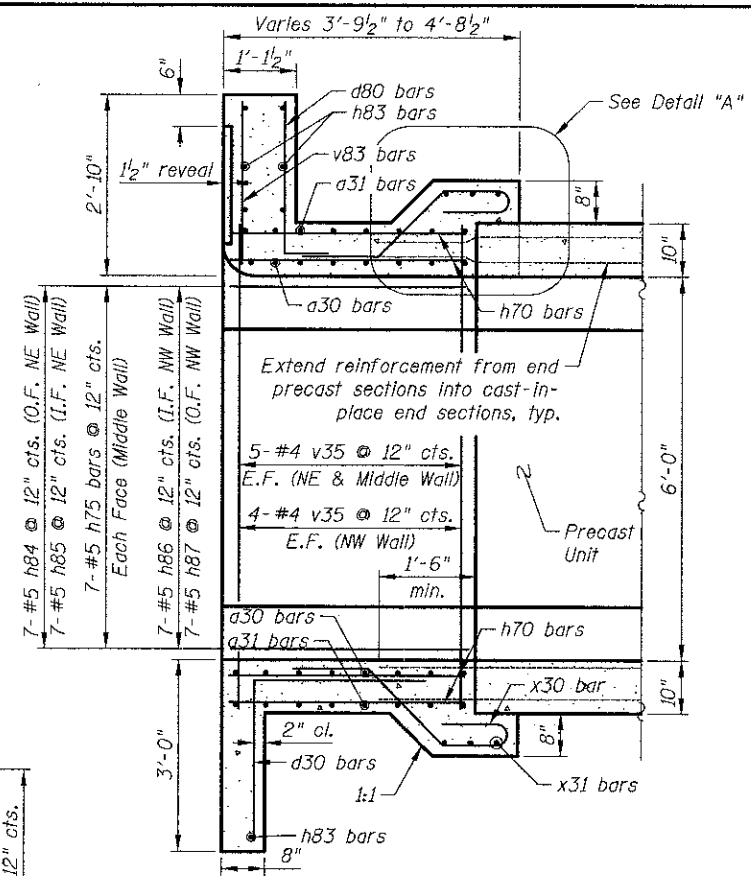

SECTION E-E

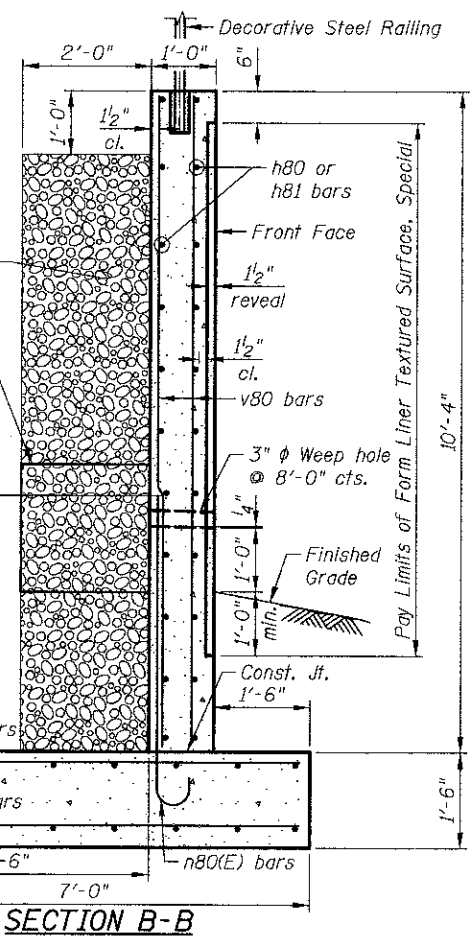

SECTION B-B

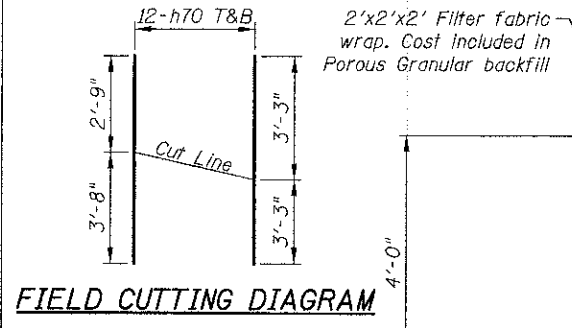

FIELD CUTTING DIAGRAM

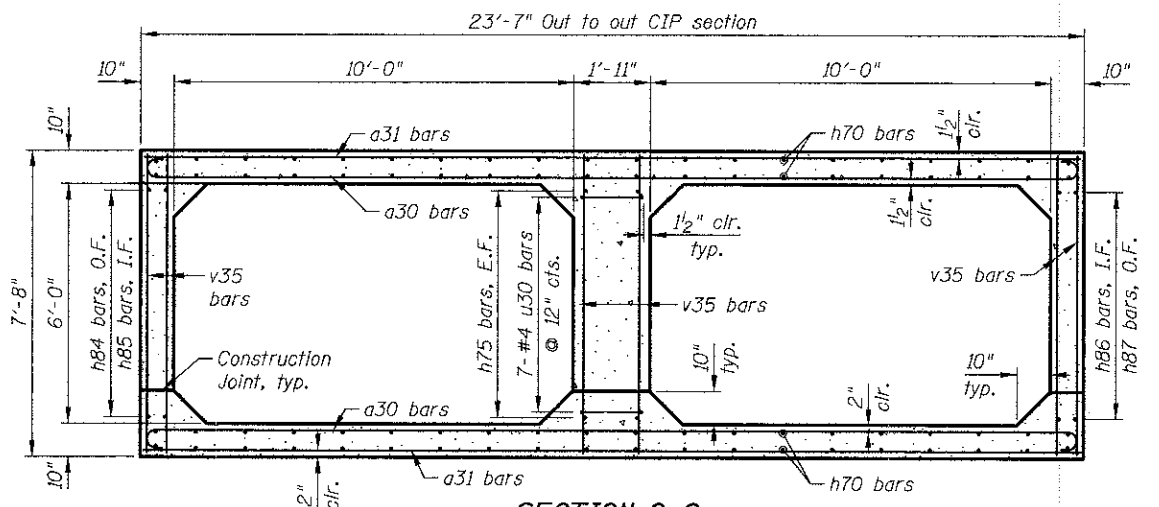

SECTION C-C

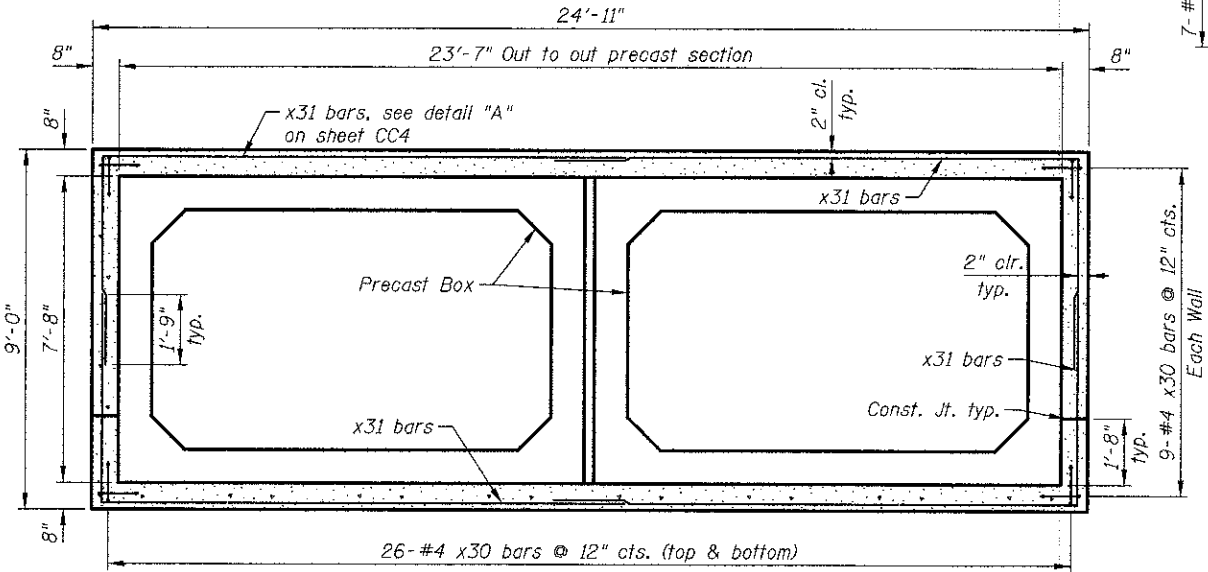

SECTION D-D

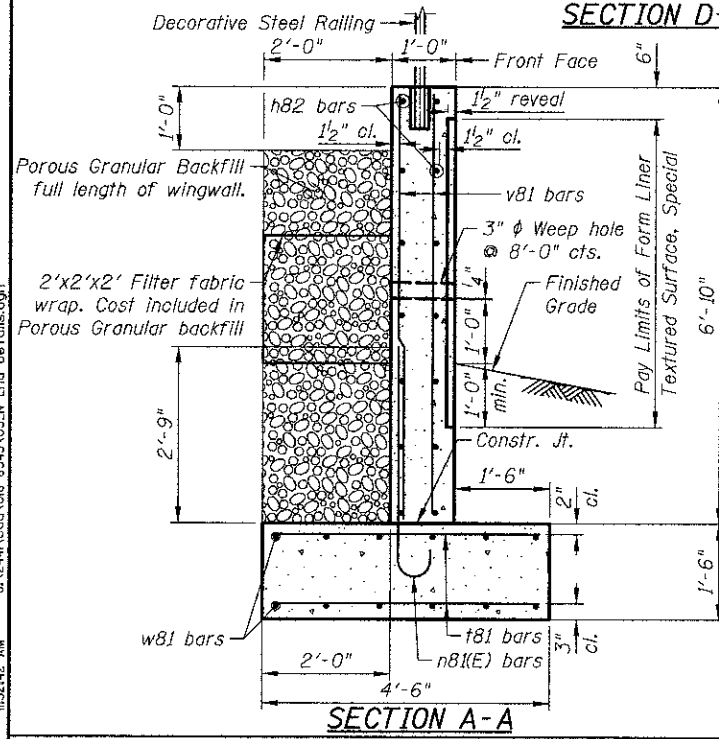

SECTION A-A

11/30/12 AM
 JA:244\cc\016-6343\05_N_End_Details.dgn
 12/12/2012

CIVILTECH
 450 E Devon Ave, Suite 300
 Itasca, Illinois 60143
 Tel: 630.773.3900 Fax: 630.773.3975
 www.civiltechinc.com

DRAWN - J. SCHROEDER
 DESIGNED - D. ATKINS
 CHECKED - G. HATLESTAD
 DATE - DECEMBER 17, 2012

REVISED -
 REVISED -
 REVISED -
 REVISED -

**STATE OF ILLINOIS
 DEPARTMENT OF TRANSPORTATION**

**NORTH END SECTION DETAILS
 HASSELL ROAD OVER POPLAR CREEK
 STRUCTURE NO. 016-6343**

SHEET NO. CC5 OF CC7 SHEETS

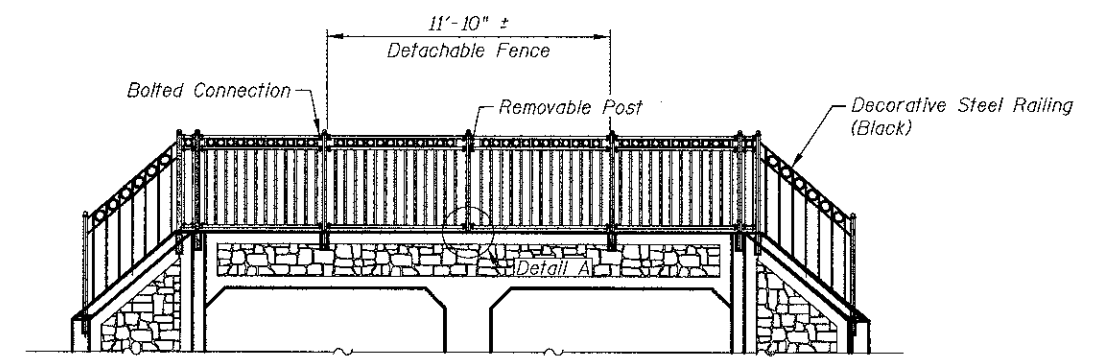
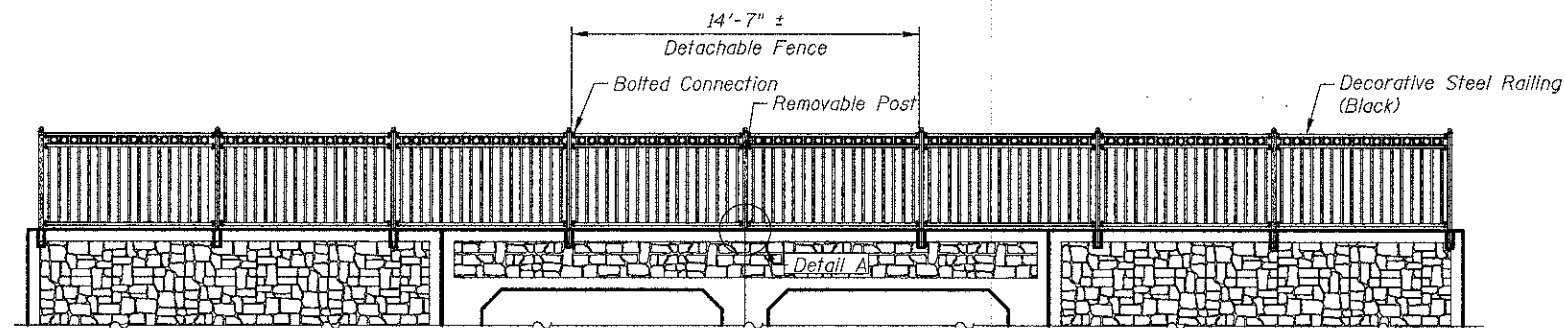
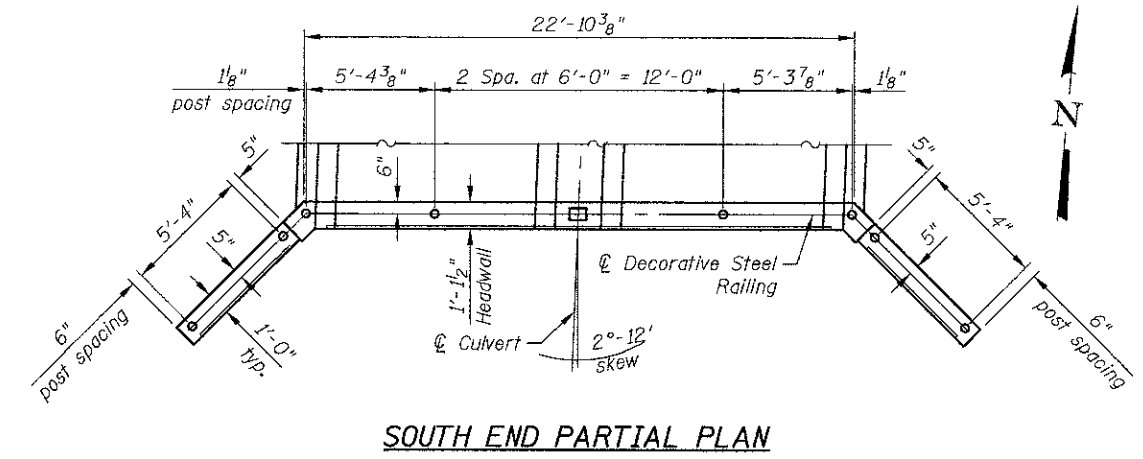
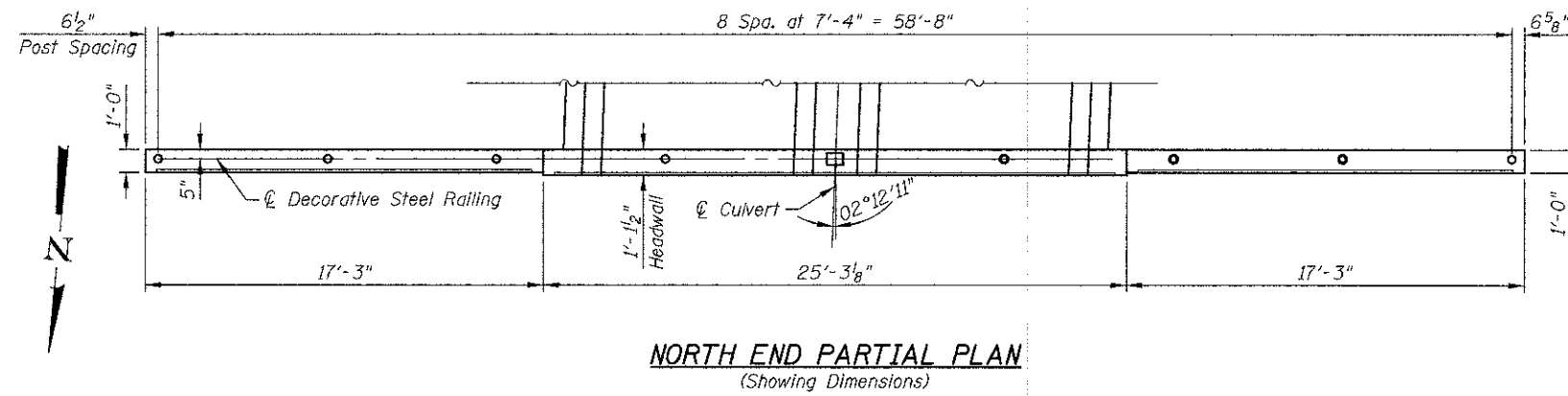

NORTH END VIEW - ELEVATION

SOUTH END VIEW - ELEVATION

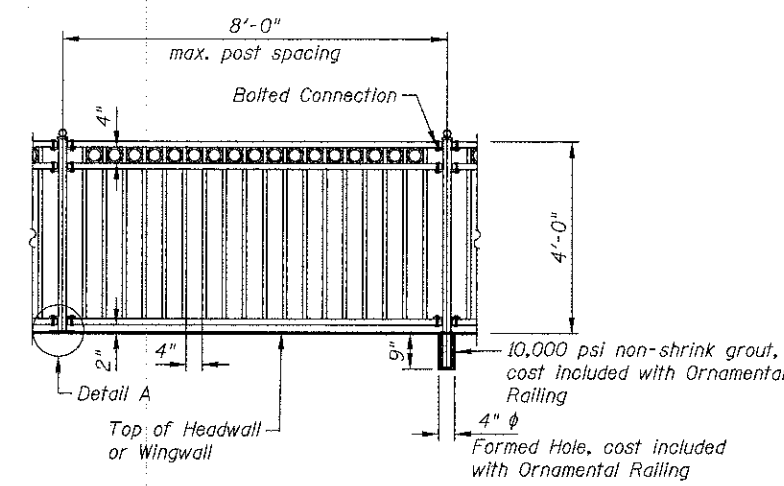
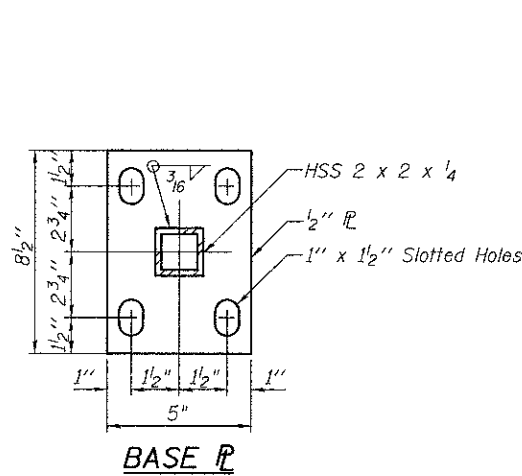

TYPICAL RAILING ELEVATION

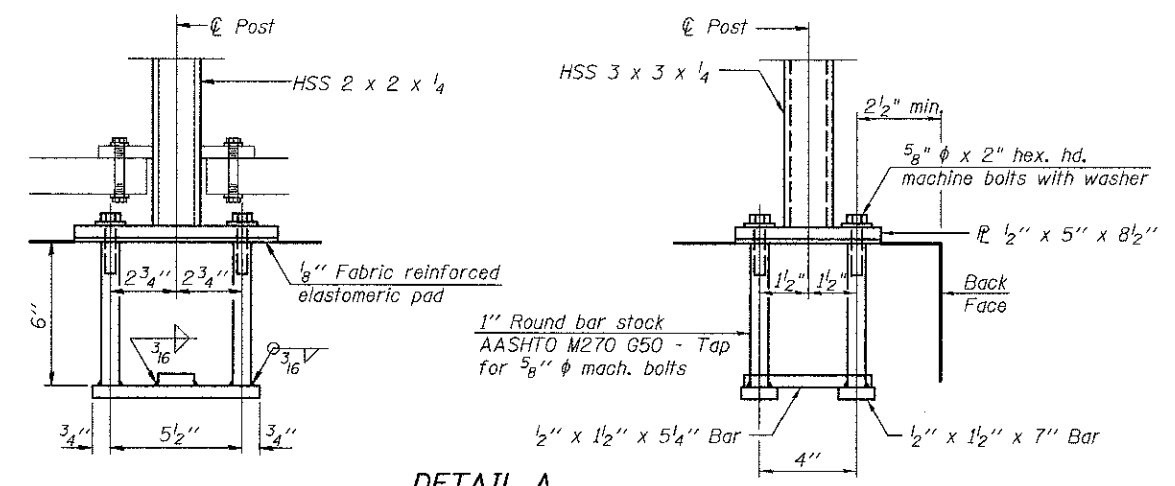

DETAIL A

BILL OF MATERIAL

Item	Unit	Quantity
Decorative Steel Railing	Foot	95

2/12/2012 10:32:44 AM J:\2441\cadd\016-6343\05_Railing_Details.dgn

450 E Devon Ave, Suite 300
Itasca, Illinois 60143
Tel: 630.773.3900 Fax: 630.773.3975
www.civiltechinc.com

DRAWN	- J. SCHROEDER	REVISED	-
DESIGNED	- D. ATKINS	REVISED	-
CHECKED	- G. HATLESTAD	REVISED	-
DATE	- DECEMBER 17, 2012	REVISED	-

**STATE OF ILLINOIS
DEPARTMENT OF TRANSPORTATION**

**DECORATIVE STEEL RAILING DETAILS
HASSELL ROAD OVER POPLAR CREEK
STRUCTURE NO. 016-6343**

F.A.I. RTE.	SECTION	COUNTY	TOTAL SHEETS	SHEET NO.
1100	11-00087-00-FP	COOK	164	120
CONTRACT NO. 63770				
ILLINOIS FED. AID PROJECT CMM 90037571				

SHEET NO. CC6 OF CC7 SHEETS

MSET PROJECT NO.: 10452		LOG OF BORING NO. B-5		Page 1 of 1						
PROJECT: Hassel Road Culvert Replacement		SITE LOCATION: Hoffman Estates, IL								
BORING LOCATION: STA 77+70, 35' N of CL		CLIENT: Hey & Associates								
DEPTH (feet)	SOIL TYPE	Material Description	Elevation	SAMPLE		TESTS		REMARKS		
				TYPE/INTERVAL	NO.	N-VALUE Blows per ft.	Wc%		Dry Unit Weight, pcf	Unconfined Compressive Strength, tsf
0		Dark Brown and Black Silty CLAY: fill, very stiff	793.5	SS	1	13	25	--	2.5 (p)	
		trace Organics		SS	2	12	19	--	2.5 (p)	
5		Black Organic CLAY (OH), trace Peat fibers	788.0	SS	3	10	59	--	--	
		Olive-Grey Organic SILT (OL), trace peat fibers, soft	785.5	SS	4	3	87	50	0.39	
10		Grey SAND (f-c), trace Gravel (SP)	782.0	SS	5	3	19	--	--	
		Grey Silty CLAY, little Sand, trace Gravel (CL), firm to very stiff	780.5	SS	6	10	23	103	2.33	
15				SS	7	13	21	107	0.85	
20				SS	8	14	18	108	2.95	
25				SS	9	13	22	107	2.48	
30		Grey SAND (f-c) and GRAVEL (SP-GP), medium dense	765.5	SS	10	25	10	--	--	
		End of Boring @ 30'	763.5							Hole Caved @ 24.3' upon completion

WATER LEVEL OBSERVATIONS, ft.
 DURING DRILLING: 11.5'
 IMMEDIATELY AFTER DRILLING: 8.5'
 DELAYED READING AFTER: 8.5'



BORING STARTED: 12/9/10
 BORING COMPLETED: 12/9/10
 LOGGED BY: SPE
 BORING METHOD: CFA

MSET PROJECT NO.: 10452		LOG OF BORING NO. B-6		Page 1 of 1						
PROJECT: Hassel Road Culvert Replacement		SITE LOCATION: Hoffman Estates, IL								
BORING LOCATION: STA 77+80, 20' S of CL		CLIENT: Hey & Associates								
DEPTH (feet)	SOIL TYPE	Material Description	Elevation	SAMPLE		TESTS		REMARKS		
				TYPE/INTERVAL	NO.	N-VALUE Blows per ft.	Wc%		Dry Unit Weight, pcf	Unconfined Compressive Strength, tsf
0		Black and Dark Brown Silty CLAY: fill	793.9	SS	1	10	3	--	--	
		Brown Crushed Limestone over Brown SAND (f-c) and GRAVEL: fill, slightly dense	792.4	SS	2	4	5	--	--	
5		Black Organic CLAY, trace Peat Fibers, (OH)	787.4	SS	3	4	238	--	0.25 (p)	
		to Olive-Grey Organic SILT (OL)		SS	4	2	64	60	0.50	
10		Grey Silty CLAY, trace Sand and Gravel (CL), stiff	782.4	SS	5	4	24	102	1.24	
15				SS	6	4	21	106	1.47	
20				SS	7	9	15	120	1.40	
25				SS	8	9	12	127	1.24	
30		Grey SAND (f-c) and GRAVEL (SP-GP), medium dense	766.9	SS	9	17	23	106	1.16	
		End of Boring @ 30'	763.9	SS	10	23	8	--	--	Hole Caved @ 6.1' upon completion

WATER LEVEL OBSERVATIONS, ft.
 DURING DRILLING: 5.5'
 IMMEDIATELY AFTER DRILLING: 5.5'
 DELAYED READING AFTER: 5.5'



BORING STARTED: 12/9/10
 BORING COMPLETED: 12/9/10
 LOGGED BY: SPE
 BORING METHOD: CFA

J:\21461\cdd\016-6343\07_Boring_Logs.dgn
 11/22/2012 8:32:47 AM



450 E Devon Ave, Suite 300
 Itasca, Illinois 60143
 Tel: 630.773.3900 Fax: 630.773.3975
 www.civiltechinc.com

DRAWN - J. SCHROEDER
 DESIGNED - D. ATKINS
 CHECKED - G. HATLESTAD
 DATE - DECEMBER 17, 2012

REVISED -
 REVISED -
 REVISED -
 REVISED -

STATE OF ILLINOIS
 DEPARTMENT OF TRANSPORTATION

SOIL BORING LOGS
 HASSELL ROAD OVER POPLAR CREEK
 STRUCTURE NO. 016-6343

SHEET NO. C07 OF C07 SHEETS

F.A.U. RTE.	SECTION	COUNTY	TOTAL SHEETS	SHEET NO.
1100	11-00087-00-FP	COOK	164	121
CONTRACT NO. 63770				
ILLINOIS FED. AID PROJECT CMM 9003757				

Illinois Department of Transportation
SOIL BORING LOG
 Page 1 of 1
 Date: 5/26/12
 ROUTE: FAU 1100 DESCRIPTION: Hassell Road from Peabody Avenue to Fairway Court
 SECTION: 11-0087-00-FP LOCATION: SEC. 6, TWP. 41N, RNG. 10E, 3rd PM
 COUNTY: Cook DRILLING METHOD: HSA HAMMER TYPE: AUTO

STRUCT. NO. _____ Station _____
 SURFACE WATER Elev. _____ ft
 STREAM BED Elev. _____ ft
 BORING NO. 3
 Station 82550
 Offset 10.37 FT
 Ground Surface Elev. 784.50 ft

Approx. 4 1/2" Asphalt
 Approx. 6" Aggregate Base
 FILL CLAY
 CLAY
 CLAY-LAM
 SANDY LOAM
 SANDY LOAM
 End of Boring

The Unconfined Compressive Strength (UCS) Failure Mode is indicated by (B-Edge, S-Shear, P-Penetrometer).
 The SPT (N value) is the sum of the last two blow values in each sampling zone (ASTM D 1586) BSS, form 137 (Rev. 9-89)

Illinois Department of Transportation
SOIL BORING LOG
 Page 1 of 1
 Date: 5/26/12
 ROUTE: FAU 1100 DESCRIPTION: Hassell Road from Peabody Avenue to Fairway Court
 SECTION: 11-0087-00-FP LOCATION: SEC. 6, TWP. 41N, RNG. 10E, 3rd PM
 COUNTY: Cook DRILLING METHOD: HSA HAMMER TYPE: AUTO

STRUCT. NO. _____ Station _____
 SURFACE WATER Elev. _____ ft
 STREAM BED Elev. _____ ft
 BORING NO. 10
 Station 82545
 Offset 21.52 FT
 Ground Surface Elev. 785.50 ft

Approx. 5" Asphalt
 Approx. 7" Aggregate Base
 FILL CLAY-LAM
 CLAY
 CLAY
 CLAY
 CLAY
 CLAY
 End of Boring

The Unconfined Compressive Strength (UCS) Failure Mode is indicated by (B-Edge, S-Shear, P-Penetrometer).
 The SPT (N value) is the sum of the last two blow values in each sampling zone (ASTM D 1586) BSS, form 137 (Rev. 9-89)

Illinois Department of Transportation
SOIL BORING LOG
 Page 1 of 1
 Date: 5/26/12
 ROUTE: FAU 1100 DESCRIPTION: Hassell Road from Peabody Avenue to Fairway Court
 SECTION: 11-0087-00-FP LOCATION: SEC. 6, TWP. 41N, RNG. 10E, 3rd PM
 COUNTY: Cook DRILLING METHOD: HSA HAMMER TYPE: AUTO

STRUCT. NO. _____ Station _____
 SURFACE WATER Elev. _____ ft
 STREAM BED Elev. _____ ft
 BORING NO. 11
 Station 82540
 Offset 12.82 FT
 Ground Surface Elev. 801.50 ft

Approx. 5 1/2" Asphalt
 Approx. 7" Aggregate Base
 FILL CLAY
 CLAY
 CLAY
 CLAY
 CLAY
 CLAY
 CLAY
 CLAY
 End of Boring

The Unconfined Compressive Strength (UCS) Failure Mode is indicated by (B-Edge, S-Shear, P-Penetrometer).
 The SPT (N value) is the sum of the last two blow values in each sampling zone (ASTM D 1586) BSS, form 137 (Rev. 9-89)

Illinois Department of Transportation
SOIL BORING LOG
 Page 1 of 1
 Date: 5/26/12
 ROUTE: FAU 1100 DESCRIPTION: Hassell Road from Peabody Avenue to Fairway Court
 SECTION: 11-0087-00-FP LOCATION: SEC. 6, TWP. 41N, RNG. 10E, 3rd PM
 COUNTY: Cook DRILLING METHOD: HSA HAMMER TYPE: AUTO

STRUCT. NO. _____ Station _____
 SURFACE WATER Elev. _____ ft
 STREAM BED Elev. _____ ft
 BORING NO. 12
 Station 82535
 Offset 19.38 FT
 Ground Surface Elev. 829.50 ft

Approx. 5 1/2" Asphalt
 Approx. 7" Aggregate Base
 FILL CLAY
 CLAY
 CLAY
 CLAY
 CLAY
 CLAY
 CLAY
 CLAY
 End of Boring

The Unconfined Compressive Strength (UCS) Failure Mode is indicated by (B-Edge, S-Shear, P-Penetrometer).
 The SPT (N value) is the sum of the last two blow values in each sampling zone (ASTM D 1586) BSS, form 137 (Rev. 9-89)

Illinois Department of Transportation
SOIL BORING LOG
 Page 1 of 1
 Date: 5/26/12
 ROUTE: FAU 1100 DESCRIPTION: Hassell Road from Peabody Avenue to Fairway Court
 SECTION: 11-0087-00-FP LOCATION: SEC. 6, TWP. 41N, RNG. 10E, 3rd PM
 COUNTY: Cook DRILLING METHOD: HSA HAMMER TYPE: AUTO

STRUCT. NO. _____ Station _____
 SURFACE WATER Elev. _____ ft
 STREAM BED Elev. _____ ft
 BORING NO. 15
 Station 82527
 Offset 19.47 FT
 Ground Surface Elev. 826.00 ft

Approx. 6" Asphalt
 Approx. 8" Aggregate Base
 FILL CLAY
 CLAY
 CLAY
 CLAY
 CLAY
 CLAY
 CLAY
 CLAY
 CLAY
 End of Boring

The Unconfined Compressive Strength (UCS) Failure Mode is indicated by (B-Edge, S-Shear, P-Penetrometer).
 The SPT (N value) is the sum of the last two blow values in each sampling zone (ASTM D 1586) BSS, form 137 (Rev. 9-89)

Illinois Department of Transportation
SOIL BORING LOG
 Page 1 of 1
 Date: 5/26/12
 ROUTE: FAU 1100 DESCRIPTION: Hassell Road from Peabody Avenue to Fairway Court
 SECTION: 11-0087-00-FP LOCATION: SEC. 6, TWP. 41N, RNG. 10E, 3rd PM
 COUNTY: Cook DRILLING METHOD: HSA HAMMER TYPE: AUTO

STRUCT. NO. _____ Station _____
 SURFACE WATER Elev. _____ ft
 STREAM BED Elev. _____ ft
 BORING NO. 16
 Station 82522
 Offset 16.57 FT
 Ground Surface Elev. 825.50 ft

Approx. 6" Asphalt
 Approx. 4" Aggregate Base
 FILL CLAY
 CLAY
 CLAY
 CLAY
 CLAY
 CLAY
 CLAY
 CLAY
 End of Boring

The Unconfined Compressive Strength (UCS) Failure Mode is indicated by (B-Edge, S-Shear, P-Penetrometer).
 The SPT (N value) is the sum of the last two blow values in each sampling zone (ASTM D 1586) BSS, form 137 (Rev. 9-89)

Illinois Department of Transportation
SOIL BORING LOG
 Page 1 of 1
 Date: 5/26/12
 ROUTE: FAU 1100 DESCRIPTION: Hassell Road from Peabody Avenue to Fairway Court
 SECTION: 11-0087-00-FP LOCATION: SEC. 6, TWP. 41N, RNG. 10E, 3rd PM
 COUNTY: Cook DRILLING METHOD: HSA HAMMER TYPE: AUTO

STRUCT. NO. _____ Station _____
 SURFACE WATER Elev. _____ ft
 STREAM BED Elev. _____ ft
 BORING NO. 18
 Station 82514
 Offset 15.58 FT
 Ground Surface Elev. 822.00 ft

Approx. 6 1/2" Asphalt
 Approx. 6 1/2" Aggregate Base
 FILL CLAY
 CLAY
 CLAY
 CLAY
 CLAY
 CLAY
 CLAY
 CLAY
 CLAY
 End of Boring

The Unconfined Compressive Strength (UCS) Failure Mode is indicated by (B-Edge, S-Shear, P-Penetrometer).
 The SPT (N value) is the sum of the last two blow values in each sampling zone (ASTM D 1586) BSS, form 137 (Rev. 9-89)

Illinois Department of Transportation
SOIL BORING LOG
 Page 1 of 1
 Date: 5/26/12
 ROUTE: FAU 1100 DESCRIPTION: Hassell Road from Peabody Avenue to Fairway Court
 SECTION: 11-0087-00-FP LOCATION: SEC. 6, TWP. 41N, RNG. 10E, 3rd PM
 COUNTY: Cook DRILLING METHOD: HSA HAMMER TYPE: AUTO

STRUCT. NO. _____ Station _____
 SURFACE WATER Elev. _____ ft
 STREAM BED Elev. _____ ft
 BORING NO. 19
 Station 82503
 Offset 18.57 FT
 Ground Surface Elev. 827.00 ft

Approx. 4" Asphalt
 Approx. 6" Aggregate Base
 FILL CLAY
 CLAY
 CLAY
 CLAY
 CLAY
 CLAY
 CLAY
 CLAY
 CLAY
 End of Boring

The Unconfined Compressive Strength (UCS) Failure Mode is indicated by (B-Edge, S-Shear, P-Penetrometer).
 The SPT (N value) is the sum of the last two blow values in each sampling zone (ASTM D 1586) BSS, form 137 (Rev. 9-89)

PLAN
 CHECKED BY _____
 DATE _____
 DRAWN BY _____
 DATE _____
 CHECKED BY _____
 DATE _____

PROFILE
 CHECKED BY _____
 DATE _____
 DRAWN BY _____
 DATE _____
 CHECKED BY _____
 DATE _____

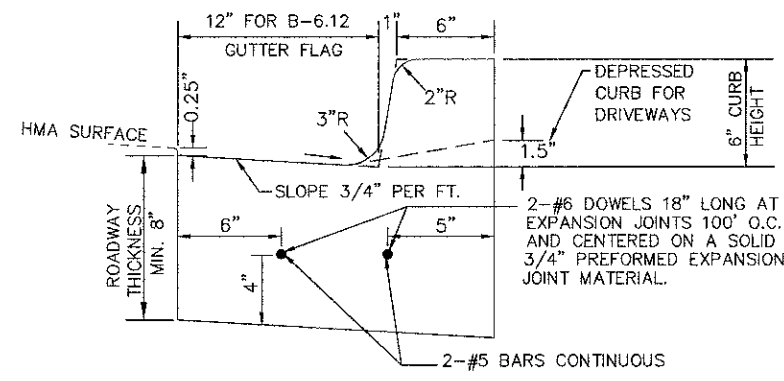

TYPE B6.12 CURB AND GUTTER

NOTES:

1. THE CURB SHALL BE DEPRESSED AT ALL APRONS AND ACROSS ALL SIDEWALK RAMPING IN ACCORDANCE WITH STANDARD 424001, 424011, 424021 AND ADA GUIDELINES.
2. CONTRACTION JOINTS TO BE TOOLED OR SAWCUT EVERY 15' TO A DEPTH OF 1.5".
3. EXPANSION JOINTS SHALL BE PROVIDED AT THE BEGINNING AND END OF ALL RETURN RADII, 5 FEET EITHER SIDE OF A DRAINAGE STRUCTURE, AT THE END OF A DAY'S POUR, AND/OR AT SPACING NOT TO EXCEED 100 FEET.

NOTE: ALL ITEMS LISTED ARE CONSIDERED INCIDENTAL TO THE APPLICABLE PAY ITEM.

CURB AND GUTTER DETAIL

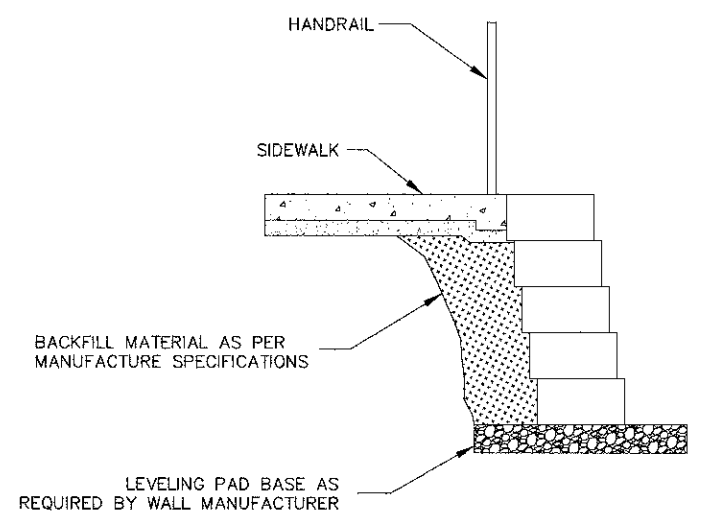

NOTE: BACKFILL AND LEVELING PAD BASE ARE INCIDENTAL TO SEGMENTAL BLOCK RETAINING WALL.

SEGMENTAL BLOCK RETAINING WALL TYPICAL SECTION

THE PROPOSED BLOCK, CAP BLOCK AND END UNITS OF THE SEGMENTAL BLOCK RETAINING WALL SHALL MATCH THE TYPE, COLOR, SIZE AND TEXTURE OF THE EXISTING RETAINING WALL.

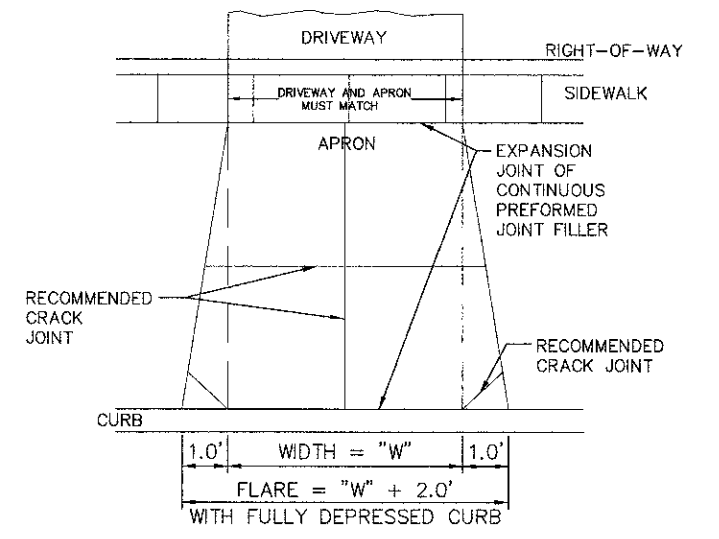

NOTE: MINIMUM WIDTH, "W" = 10', MINIMUM FLARE = 12' MAXIMUM WIDTH, "W" = 28', MAXIMUM FLARE = 30'

NOTES:

- CONCRETE
1. THE RESIDENTIAL APRON SHALL CONSIST OF 6" CONCRETE WITH 6" X 6", NO. 10 STEEL MESH REINFORCED, OVER 4" CA-6 CRUSHED STONE OR GRAVEL.
 2. THE COMMERCIAL APRON SHALL CONSIST OF 8" CONCRETE WITH 6" X 6", NO. 10 STEEL MESH REINFORCED, OVER 6" CA-6 CRUSHED STONE OR GRAVEL.
 3. CONCRETE TO BE IDOT APPROVED MIX, MIN. 3500 PSI COMPRESSIVE STRENGTH
 4. CONCRETE MUST BE CURED IN ACCORDANCE WITH CONTRACT SPECIFICATIONS
- ASPHALT
1. THE APRON SHALL CONSIST OF 2" ASPHALT OVER 10" CA-6 CRUSHED STONE OR GRAVEL.

NOTE: ALL ITEMS LISTED ARE CONSIDERED INCIDENTAL TO THE APPLICABLE DRIVEWAY PAY ITEM

APRON DETAIL

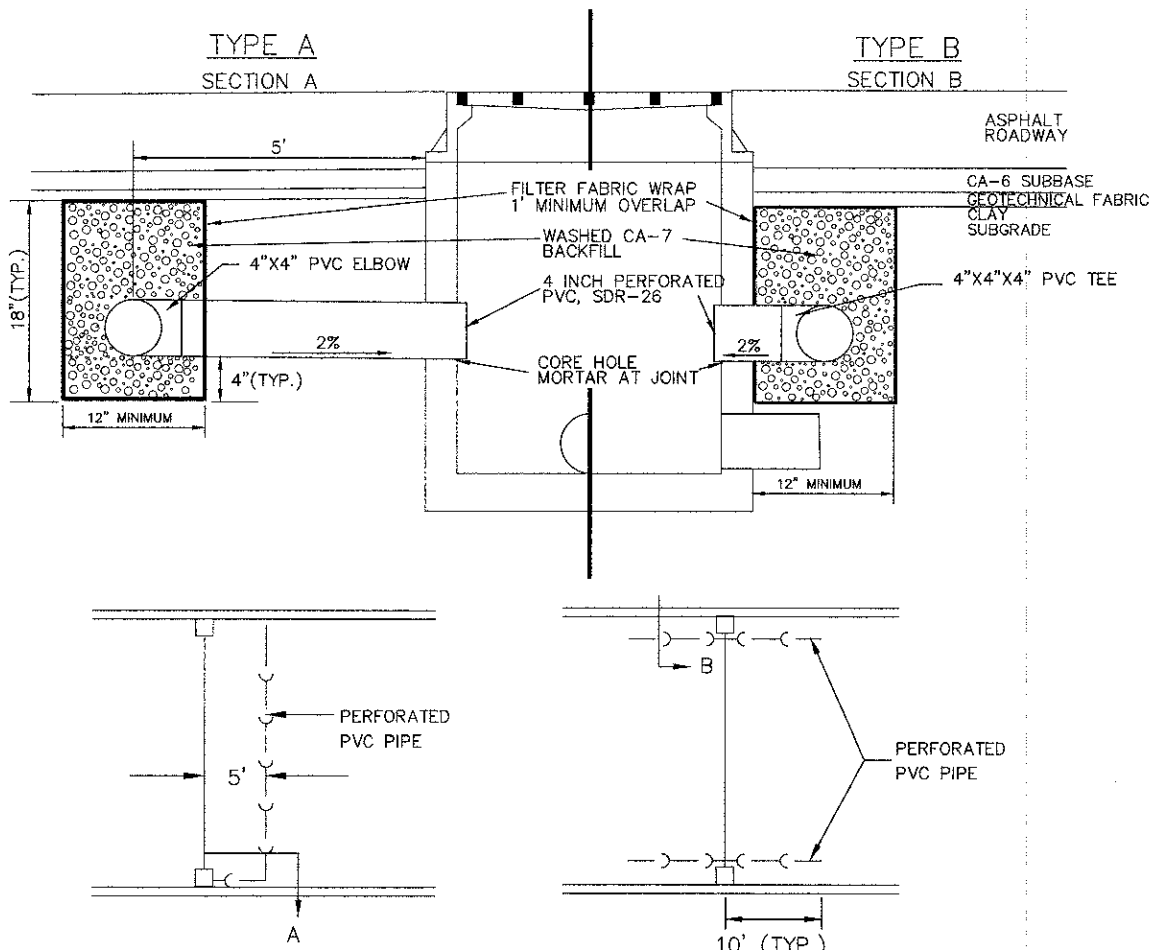

PIPE UNDERDRAIN DETAIL

NOTE: ALL ITEMS LISTED ARE CONSIDERED INCIDENTAL TO THE APPLICABLE UNDERDRAIN PAY ITEM.

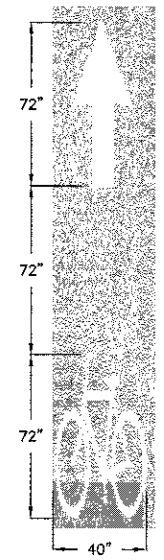

NOTES:

1. STRIPING TO BE PERFORMED THERMOPLASTIC PAVEMENT MARKING.

BIKE LANE STRIPING DETAIL

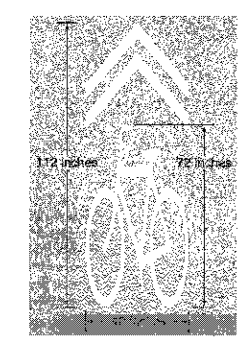

NOTES:

1. STRIPING TO BE PERFORMED THERMOPLASTIC PAVEMENT MARKING.
2. STRIPING TO BE PLACED 11 FEET (ON CENTER) FROM FACE OF CURB WHEN ADJACENT TO A PARKING LANE.

SHARROW STRIPING DETAIL

FILE NAME =
DETAILSH.DWG

DESIGNED --	REVISED --
DRAWN --	REVISED --
CHECKED --	REVISED --
DATE --	REVISED --

STATE OF ILLINOIS
DEPARTMENT OF TRANSPORTATION

Hassell Road STP Project
Details

SCALE: NONE SHEET NO. 1 OF 4 SHEETS STA. TO STA.

F.A.U. RTE.	SECTION	COUNTY	TOTAL SHEETS	SHEET NO.
1100	11-00087-00-FP	Cook	164	125
CONTRACT NO. 63770				
ILLINOIS FED. AID PROJECT CMM 9003(757)				

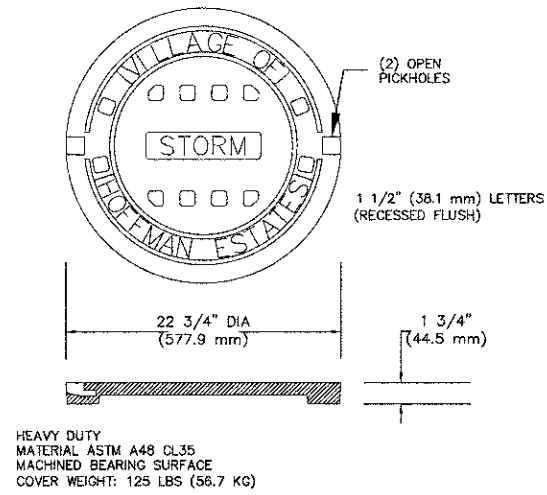

HEAVY DUTY
MATERIAL ASTM A48 CL35
MACHINED BEARING SURFACE
COVER WEIGHT: 125 LBS (56.7 KG)

STORM COVER DETAIL

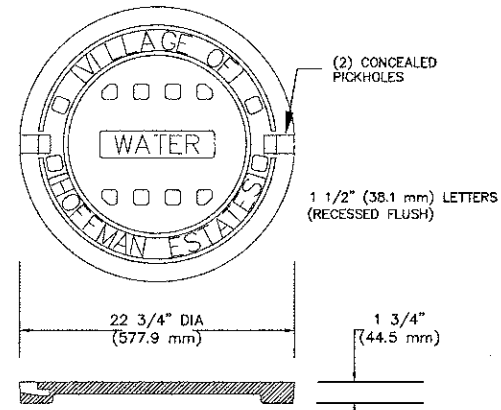

HEAVY DUTY
MATERIAL ASTM A48 CL35
MACHINED BEARING SURFACE
COVER WEIGHT: 125 LBS (56.7 KG)

WATER COVER DETAIL

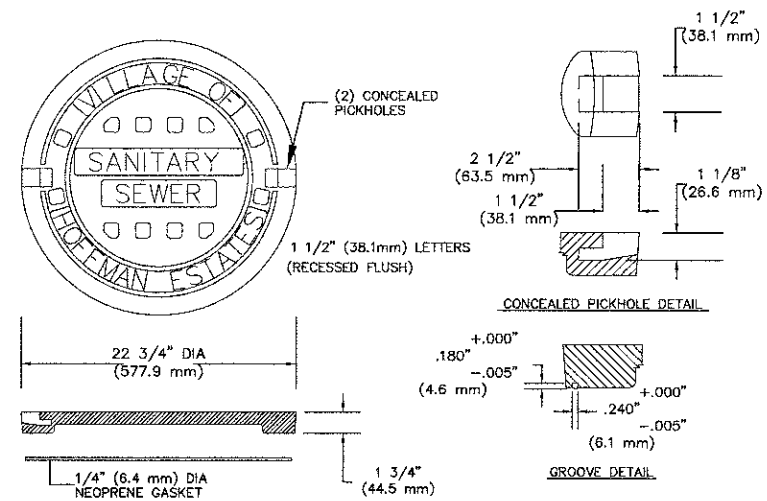

HEAVY DUTY
MATERIAL ASTM A48 CL35
MACHINED BEARING SURFACE
COVER WEIGHT: 125 LBS (56.7 KG)

MANHOLE COVER WITH GROOVED
GASKET SEAL & CONCEALED PICK
HOLES TO REDUCE SURFACE
WATER INFLOW.

SANITARY COVER DETAIL

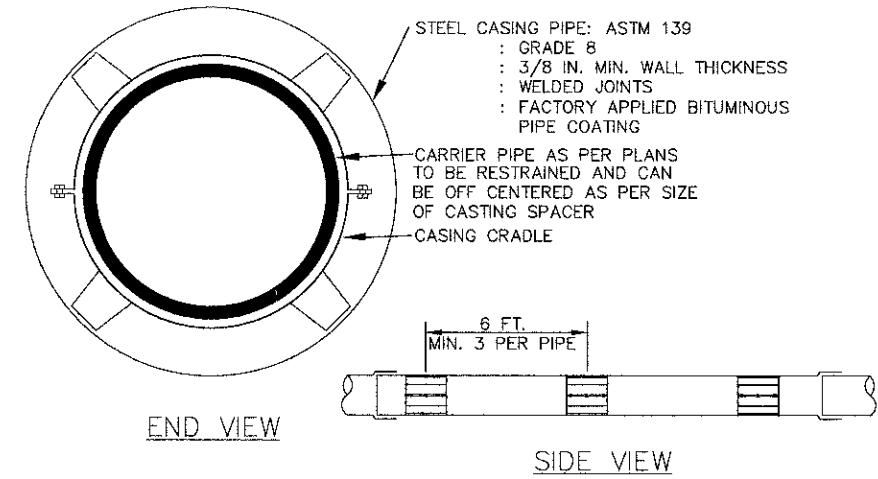

AUGER PIPE DETAIL

- NOTES:
1. PROVIDE CONCRETE BULKHEAD AT EACH END OF CASING PIPE.
 2. CRADLE SHALL BE POWERSEAL CASING CHOCK, MODEL 4810 BY POWERSEAL PIPELINE PRODUCTS CORP. OR CASCADE CASING SPACER OR APPROVED EQUAL.

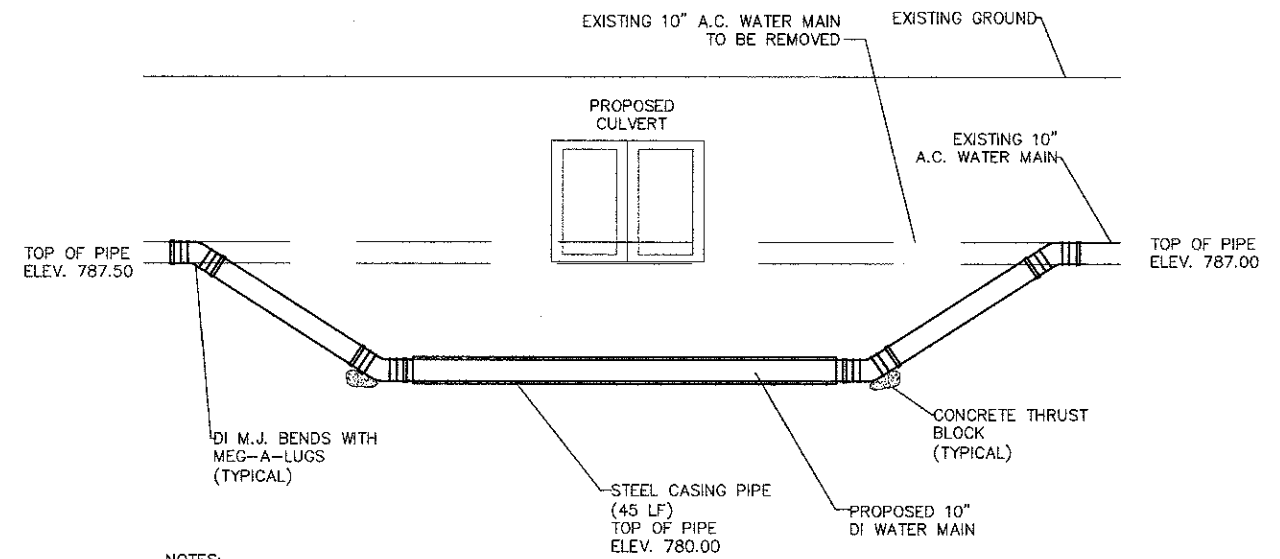

- NOTES:
1. ALL BELOW GRADE FASTENERS SHALL BE STAINLESS STEEL BOLTS: GRADE 304, NUTS AND WASHERS: GRADE 300
 2. WATER MAIN SHALL BE PLACE IN VIRGIN GROUND BENEATH PROPOSED UNDERCUT FOR CULVERT.
 3. PROVIDE 5 LF OF DI WATER MAIN CONNECTED TO EXISTING AC WATER MAIN PRIOR TO THE 45 DEGREE M.J. BENDS ON EACH SIDE.

ADJUSTING WATER MAIN 10"

FILE NAME = DETAILSH.DWG	DESIGNED —	REVISED —
	DRAWN —	REVISED —
	CHECKED —	REVISED —
	DATE —	REVISED —

**STATE OF ILLINOIS
DEPARTMENT OF TRANSPORTATION**

Hassell Road STP Project
Details

SCALE: NONE SHEET NO. 2 OF 4 SHEETS STA. TO STA.

F.A.U. RTE.	SECTION	COUNTY	TOTAL SHEETS	SHEET NO.
1100	11-00087-00-FP	Cook	164	126
CONTRACT NO. 63770				
ILLINOIS FED. AID PROJECT GMM 8003(757)				

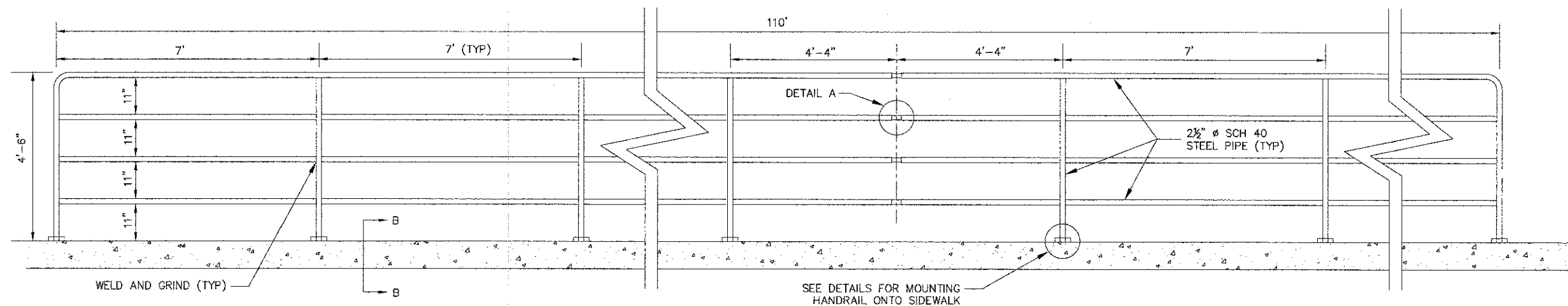

HANDRAIL ELEVATION DETAIL

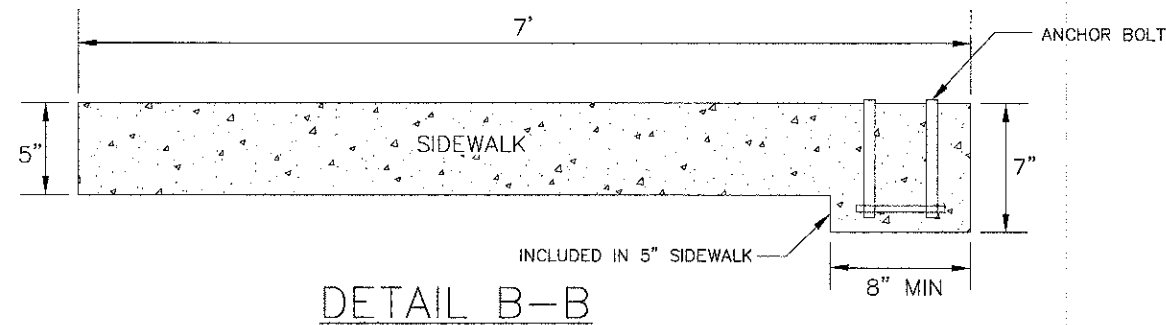

DETAIL B-B

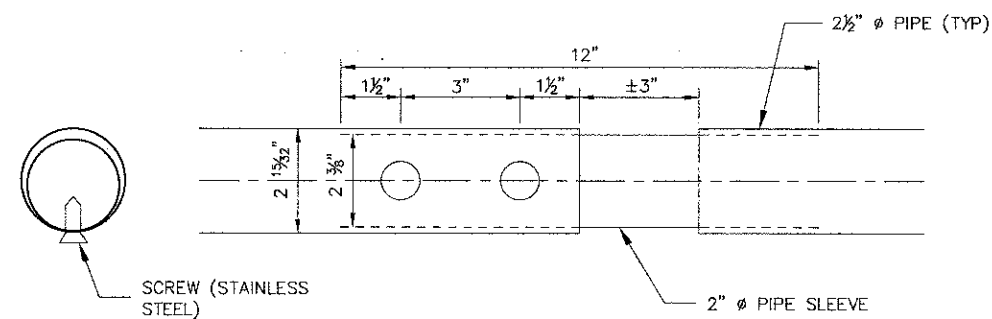

**DETAIL A
HANDRAIL EXPANSION JOINT**

HANDRAIL EXPANSION JOINT SHALL BE INSTALLED AFTER EACH INTERVAL OF THREE, 7 FOOT HANDRAIL PANELS, FOR A TOTAL OF THREE EXPANSION JOINTS IN THE 110 FOOT HANDRAIL LENGTH.

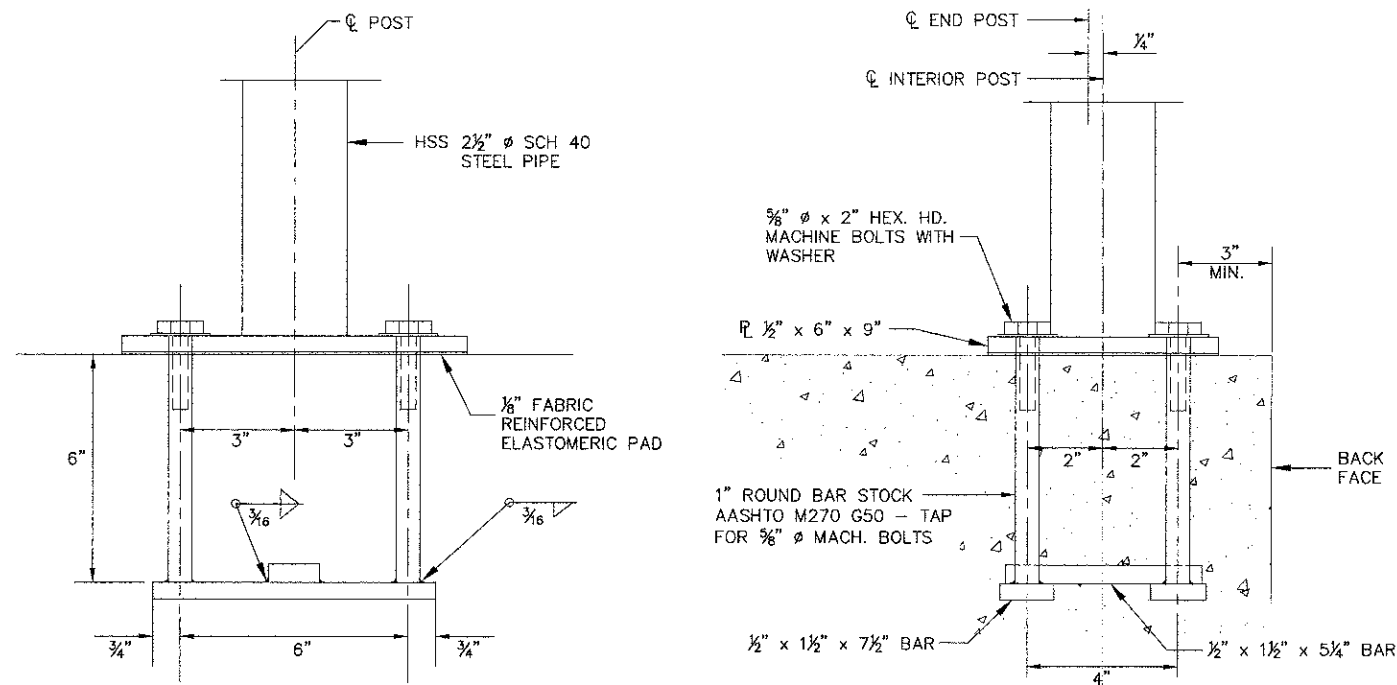

**ANCHOR BOLT DETAILS FOR MOUNTING HANDRAIL
ONTO PCC SIDEWALK 6 INCH, SPECIAL**

IN LIEU OF THE CAST-IN-PLACE ANCHOR DEVICE SHOWN, THE CONTRACTOR HAS THE OPTION OF DRILLING AND SETTING 5/8" Ø ANCHOR RODS ACCORDING TO ARTICLE 509.06 OF THE STANDARD SPECIFICATIONS. EMBEDMENT SHALL BE ACCORDING TO THE MANUFACTURER'S SPECIFICATIONS.

1. CONTRACTOR SHALL SUBMIT SHOP DRAWINGS OF THE HANDRAIL, ITS CONFIGURATIONS AND ITS INSTALLATION TO THE ENGINEER FOR APPROVAL PRIOR TO ORDERING MATERIALS.
2. RAILING SHALL BE ACCORDING TO SECTION 509 OF THE STANDARD SPECIFICATIONS, EXCEPT AS NOTED, AND WILL BE PAID FOR AT THE CONTRACT UNIT PRICE PER FOOT FOR HANDRAIL.
3. HOLLOW STRUCTURAL STEEL TUBING SHALL CONFORM TO THE REQUIREMENTS OF ASTM DESIGNATION A 500, GRADE B, STRUCTURAL STEEL TUBING.
4. ALL OTHER STEEL SHAPES AND PLATES SHALL CONFORM TO THE REQUIREMENTS OF AASHTO W 270 GRADE 36.
5. IF THE OPTION OF DRILLING AND EPOXY GROUTING THE ANCHOR RODS IS CHOSEN, THE CONTRACTOR SHALL USE THE CAPSULE OR ADHESIVE CARTRIDGE TYPE ANCHOR RODS THAT HAVE BEEN PREVIOUSLY TESTED AND GIVEN PRIOR APPROVAL BY THE DEPARTMENT. THE CONTRACTOR SHALL INSTALL THESE ANCHOR RODS IN PRE-DRILLED HOLES ACCORDING TO THE MANUFACTURER'S RECOMMENDATIONS AND PROCEDURES. THE CAPSULE OR THE ADHESIVE CARTRIDGE SHALL BE SEALED WITH PREMEASURED AMOUNTS OF THE ADHESIVE CHEMICAL.
6. SPACE REINFORCEMENT TO MISS ANCHOR RODS.
7. ALL POSTS, RAILING, SPLICES, ANCHOR DEVICES, AND PLATES SHALL BE GALVANIZED AFTER SHOP FABRICATION ACCORDING TO AASHTO M 111 AND ASTM A 385. ALL BOLTS, NUTS, WASHERS, AND ANCHOR RODS SHALL BE GALVANIZED ACCORDING TO AASHTO M 232 EXCEPT STAINLESS STEEL BOLTS AS NOTED.
8. VENT HOLES FOR GALVANIZING SHALL BE PLACED IN THE POSTS AND RAILS AT LOCATIONS THAT WILL NOT ALLOW THE ACCUMULATION OF MOISTURE IN THE MEMBERS.
9. HANDRAIL SHALL BE PAINTED BLACK PER ARTICLE 509.05.

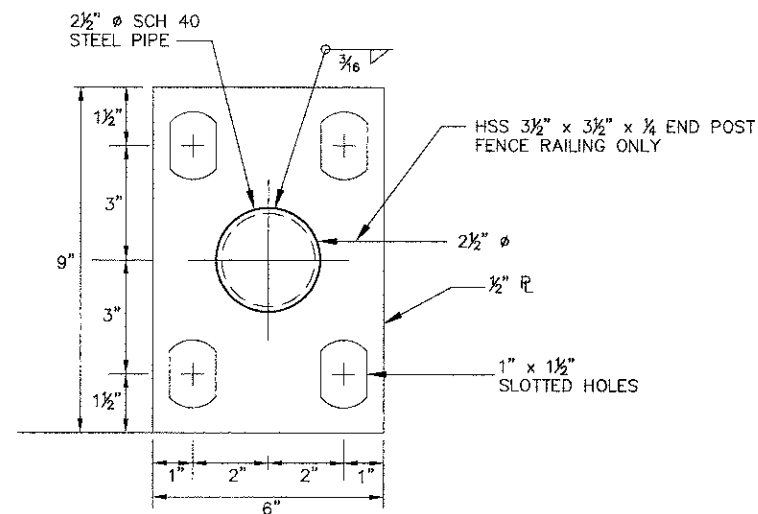

BASE R

FILE NAME = DETAILSH.DWG	DESIGNED --	REVISED --	STATE OF ILLINOIS DEPARTMENT OF TRANSPORTATION	Hassell Road STP Project Details		F.A.U. RTE.	SECTION	COUNTY	TOTAL SHEETS	SHEET NO.
	DRAWN --	REVISED --		1100	11-00087-00-FP	Cook	164	127		
	CHECKED --	REVISED --		CONTRACT NO. 63770						
	DATE --	REVISED --		ILLINOIS FED. AID PROJECT CMM 9003(757)						
				SCALE: NONE	SHEET NO. 3 OF 4 SHEETS	STA.	TO STA.			

TREE PROTECTION - FENCING

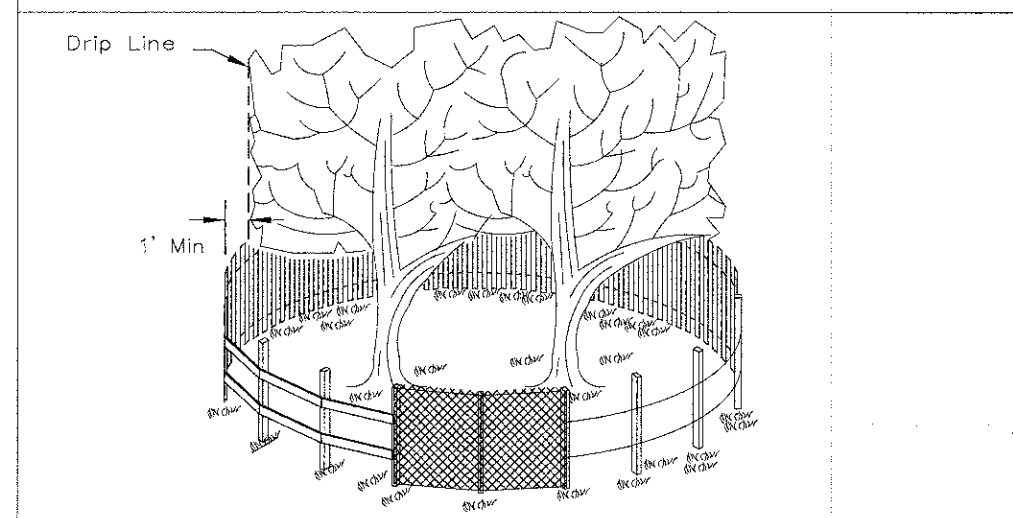

SIDE VIEW

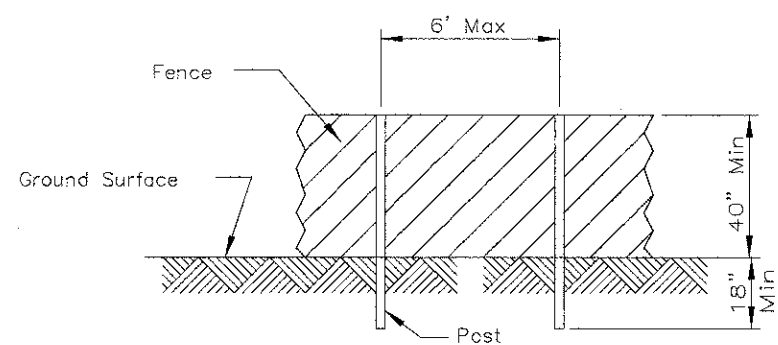

POST AND FENCE DETAIL

NOTES:

1. The fence shall be located a minimum of 1 foot outside the drip line of the tree to be saved and in no case closer than 5 feet to the trunk of any tree.
2. Fence posts shall be either standard steel posts or wood posts with a minimum cross sectional area of 3.0 sq. in.
3. The fence may be either 40" high snow fence, 40" plastic web fencing or any other material as approved by the engineer/inspector.

REFERENCE	Project	_____	Date	_____
	Designed	_____	Date	_____
	Checked	_____	Date	_____
	Approved	_____	Date	_____



STANDARD DWG. NO.
IL-690
 SHEET 1 OF 1
 DATE 4-7-94

AUTOCAD2006

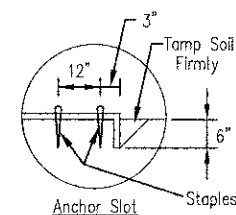
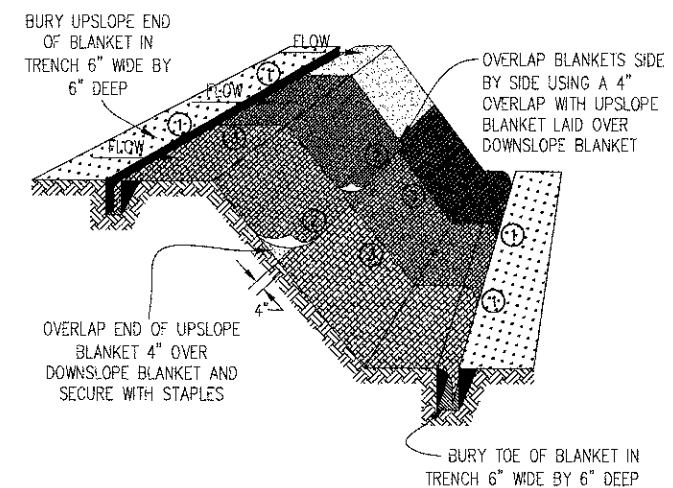

DETAIL 1

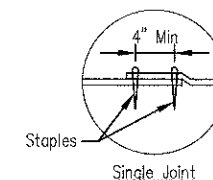

DETAIL 2

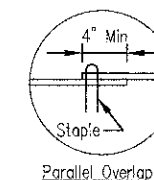

DETAIL 3

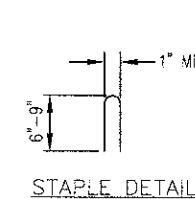

STAPLE DETAIL

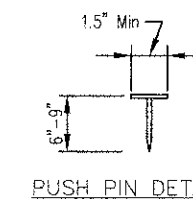

PUSH PIN DETAIL

NOTES:

1. Staples shall be placed in a diamond pattern at 2 per s.y. for stitched blankets. Non-stitched shall use 4 staples per s.y. of material. This equates to 200 staples with stitched blanket and 400 staples with non-stitched blanket per 100 s.y. of material.
2. Staple or push pin lengths shall be selected based on soil type and conditions. (minimum staple length is 6")
3. Erosion control material shall be placed in contact with the soil over a prepared seedbed.
4. All anchor slots shall be stapled at approximately 12" intervals.

EROSION CONTROL BLANKET INSTALLATION DETAILS

Designed	_____	Date	_____
Drawn	B. JOHNSON	Date	11/28
Checked	_____	Date	_____
Approved	_____	Date	_____

FILE NAME =	DESIGNED --	REVISED --
DETAILS.DWG	DRAWN --	REVISED --
	CHECKED --	REVISED --
	DATE --	REVISED --

**STATE OF ILLINOIS
 DEPARTMENT OF TRANSPORTATION**

Hassell Road STP Project
 Details

SCALE: NONE SHEET NO. 4 OF 4 SHEETS STA. TO STA.

F.A.U. RTE.	SECTION	COUNTY	TOTAL SHEETS	SHEET NO.
1100	11-00087-00-FP	Cook	164	128
CONTRACT NO. 63770				
ILLINOIS FED. AID PROJECT CMM 9003(757)				

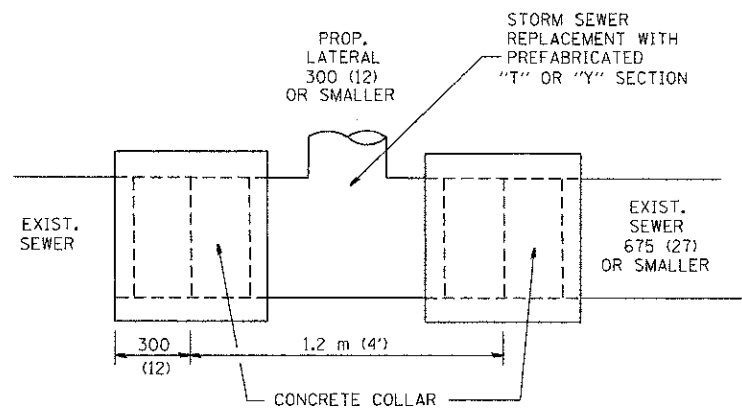

DETAIL "A"

LATERAL CONNECTION TO EXISTING SEWER OF 675 (27) OR SMALLER

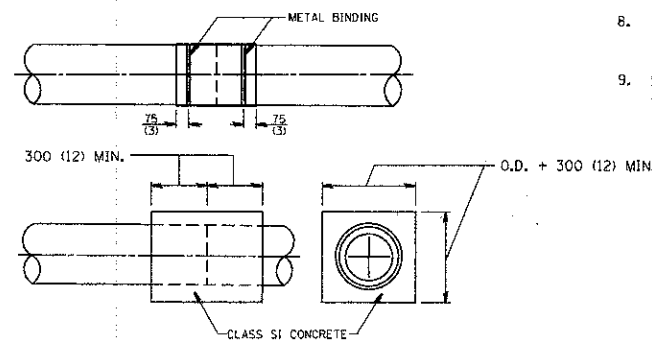
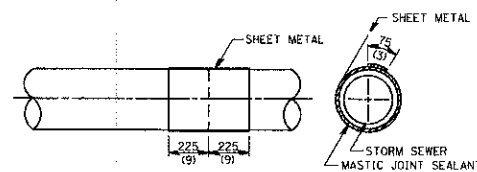
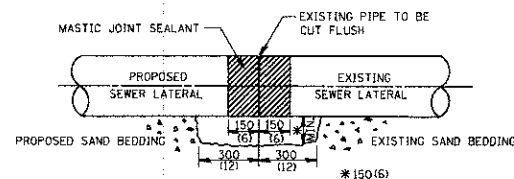

DETAIL "B"
CLASS SI CONCRETE COLLAR

CONSTRUCTION SEQUENCE

- CUT THE EXISTING END OF THE PIPE SO AS TO PRESENT A FLUSH BUTT JOINT. BRUSH AND CLEAN ALL PIPES.
- APPLY THE MASTIC JOINT SEALANT TO THE FIRST 150 (6) OF EACH PIPE.
- BUTT THE PIPES TOGETHER LEAVING A MINIMUM OF 300 x 150 (12 x 6) DEEP EXCAVATION UNDER AND AROUND EACH PIPE END.
- CUT A PIECE OF SHEET METAL GAGE NO. 19 1.1 (0.0418) 450 (18) WIDE BY THE OUTSIDE CIRCUMFERENCE OF THE PIPE PLUS 75 (3) LONG.
- WRAP THE SHEET METAL AROUND THE PIPES, 225 (9) ON EACH SIDE OF THE JOINT, STARTING AT THE TOP OF THE PIPE.
- LAP THE SHEET METAL AT LEAST 75 (3) AT THE TOP OF THE PIPE AND PLACE THE MASTIC JOINT SEALANT BETWEEN THE LAP.
- PLACE TWO METAL BANDS AROUND THE SHEET METAL AND TIGHTEN.
- WIPE OFF ANY EXCESS MASTIC JOINT SEALANT THAT OZZES OUT FROM BETWEEN THE SHEET METAL AND THE PIPES.
- PLACE CLASS SI CONCRETE AROUND THE JOINT.

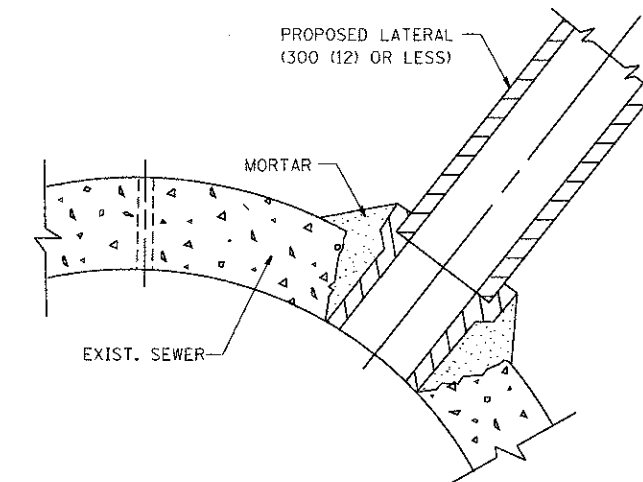

DETAIL "C"
PROPOSED LATERAL CONNECTION TO EXISTING SEWER OF 750 (30) OR LARGER

NOTES

MATERIAL

MATERIAL USED FOR THE TEE OR WYE SECTION SHALL BE COMPATIBLE WITH THE EXISTING STORM SEWER OR THE PROPOSED STORM SEWER.

CONSTRUCTION METHODS

- THIS WORK SHALL BE CONSTRUCTED IN CONFORMANCE WITH THE APPLICABLE PORTIONS OF SECTION 550 OF THE STANDARD SPECIFICATIONS.
- CONNECTION TO AN EXISTING STORM SEWER SHALL BE BY EITHER OF THE FOLLOWING METHODS:
 - PROPOSED STORM SEWER CONNECTION TO EXISTING SEWER OF 675 (27) OR SMALLER SEE DETAIL "A" AND "B".
 - PROPOSED STORM SEWER CONNECTION TO EXISTING SEWER OF 750 (30) OR LARGER SEE DETAIL "C".

IF THE EXISTING SEWER PIPE IS CRACKED, BROKEN OR OTHERWISE DAMAGED BY THE CONTRACTOR IN MAKING THE CIRCULAR OPENING, THE CONTRACTOR SHALL REPLACE THAT SECTION OF PIPE WITH PIPE EQUAL AND SIMILAR IN ALL RESPECTS TO THE PIPE IN THE EXISTING SEWER, IN A CAREFUL WORKMANLIKE MANNER, WITHOUT EXTRA COMPENSATION.

GENERAL

CARE MUST BE TAKEN TO PREVENT DEBRIS FROM ENTERING THE SEWER. ALL DEBRIS WHICH ENTERS THE SEWER MUST BE REMOVED. THE SEWER MUST BE LEFT CLEAN AND UNOBSTRUCTED UPON COMPLETION OF THE CONTRACT.

CARE MUST BE TAKEN TO PREVENT ANY PART OF THE NEW PIPE CONNECTION FROM PROJECTING INTO THE EXISTING SEWER.

BASIS OF PAYMENT

TEE OR WYE CONNECTIONS SHALL BE PAID FOR AT THE CONTRACT UNIT PRICE EACH FOR STORM SEWER TEE OR WYE OF THE TYPE AND SIZE SPECIFIED IN THE PLANS. THIS PRICE SHALL INCLUDE ALL EXCAVATION OF THE TRENCH, REMOVAL OF THE EXISTING STORM SEWER, FURNISHING AND INSTALLING THE SPECIFIED TEE OR WYE SECTION, FURNISHING AND INSTALLING THE REQUIRED CONCRETE COLLAR, AND ALL OTHER MATERIAL NECESSARY TO COMPLETE THIS WORK AS SHOWN AND SPECIFIED.

REMOVAL AND REINSTALLATION OF EXISTING STORM SEWER ADJACENT TO THE PROPOSED TEE OR WYE SECTION, FOR THE PURPOSE OF FACILITATING THE INSTALLATION OF THE TEE OR WYE SECTION, WILL NOT BE PAID FOR SEPARATELY BUT SHALL BE INCLUDED IN THE UNIT PRICE BID FOR THE WORK.

TRENCH BACKFILL, EXCAVATION IN ROCK AND REMOVAL AND REPLACEMENT OF UNSUITABLE MATERIAL BELOW PLAN BEDDING GRADE WILL BE PAID FOR SEPARATELY.

CONCRETE COLLAR FOR CONNECTING A PROPOSED STORM SEWER TO AN EXISTING STORM SEWER WILL NOT BE PAID FOR SEPARATELY BUT SHALL BE INCLUDED IN THE COST OF THE PROPOSED STORM SEWER.

ALL DIMENSIONS ARE IN MILLIMETERS (INCHES) UNLESS OTHERWISE SHOWN.

REVISIONS	
NAME	DATE
M. DE YONG	07/25/90
M. DE YONG	02/05/92
M. DE YONG	05/08/92
R. SHAH	09/09/94
R. SHAH	10/25/94
R. SHAH	06/12/96

ILLINOIS DEPARTMENT OF TRANSPORTATION
DETAIL OF STORM SEWER CONNECTION TO EXISTING SEWER

SCALE: VERT.
HORIZ.
DATE: 2/15/2006

DRAWN BY
CHECKED BY

BD500-01 (BD-7)
REVISION DATE: 06/12/96

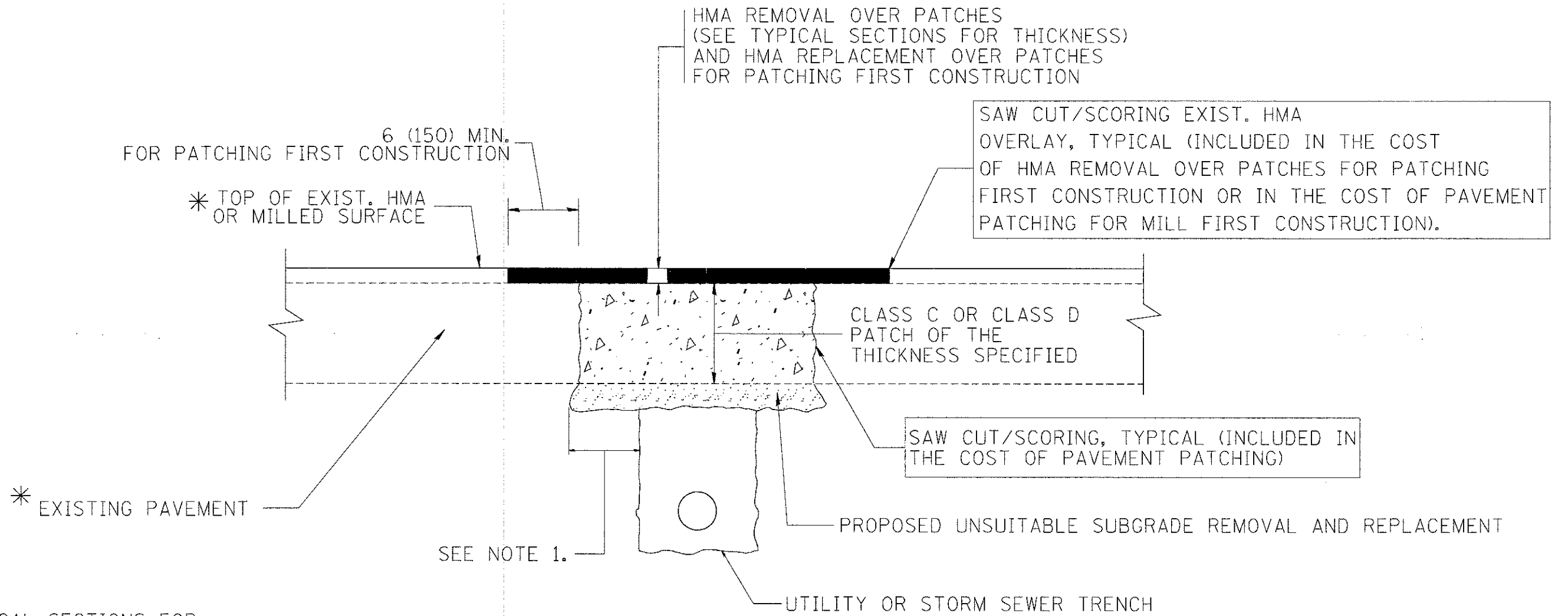

* SEE TYPICAL SECTIONS FOR THICKNESS AND MATERIALS

NOTES:

1. THE WIDTH OF THE FULL DEPTH PATCH OVER A TRENCH SHALL BE 12 (300) WIDER ON EACH SIDE OF THE TRENCH.
2. FOR METHOD OF MEASUREMENT AND BASIS OF PAYMENT, SEE RECURRING SPECIAL PROVISION "PATCHING WITH HOT-MIX ASPHALT OVERLAY REMOVAL".

SEQUENCE OF CONSTRUCTION (PATCHING FIRST)

1. REMOVE THE EXISTING HMA MATERIAL OVER THE AREA TO BE PATCHED.
2. REMOVE AND REPLACE WITH CLASS C OR D PATCH.
3. REPLACE HMA MATERIAL OVER THE AREA TO BE PATCHED.

SEQUENCE OF CONSTRUCTION (MILLING FIRST)

1. MILL HMA FIRST IF THERE IS AT LEAST 4 1/2 INCHES OR MORE OF HMA MATERIAL ON TOP OF THE EXISTING PAVEMENT OR IF THE PAVEMENT IS FULL DEPTH HMA. A MINIMUM OF 2 INCHES OF HMA MATERIAL SHALL BE IN PLACE AFTER MILLING.
2. REMOVE AND REPLACE WITH FULL DEPTH CLASS D PATCHES TO TOP OF MILLED SURFACE.

ALL DIMENSIONS ARE IN INCHES (MILLIMETERS) UNLESS OTHERWISE SHOWN.

FILE NAME = c:\projects\diststd22x34\bd22.dgn	USER NAME = bouerd1	DESIGNED - R. SHAH	REVISED - A. ABBAS 04-27-98	STATE OF ILLINOIS DEPARTMENT OF TRANSPORTATION	PAVEMENT PATCHING FOR HMA SURFACED PAVEMENT			F.A. RTE.	SECTION	COUNTY	TOTAL SHEETS	SHEET NO.
		DRAWN -	REVISED - R. BORO 01-01-07		1100	11-00087-00-FP	COOK	164	130			
		PLOT SCALE = 50.000' / IN.	REVISED - R. BORO 09-04-07		BD400-04 (BD-22)			CONTRACT NO. 63770				
		CHECKED -	REVISED - K. ENG 10-27-08		SCALE: NONE	SHEET NO. 1 OF 1 SHEETS	STA.	TO STA.		FED. ROAD DIST. NO. 1 ILLINOIS FED. AID PROJECT CMM 9003 (757)		
		PLOT DATE = 10/27/2008	DATE = 10-25-94									

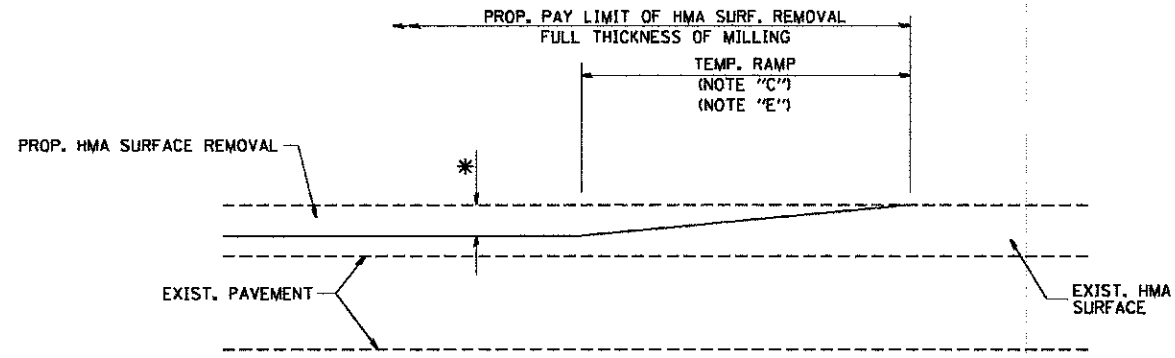

MILLED TEMPORARY RAMP
(FOR BUTT JOINT AND HMA TAPER SEE DETAIL BELOW)

OPTION 1

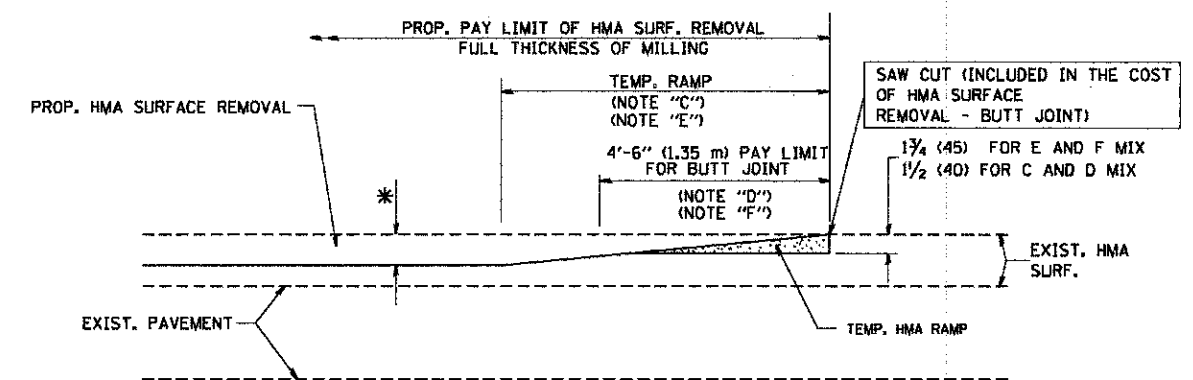

HMA CONSTRUCTED TEMPORARY RAMP
(FOR BUTT JOINT AND HMA TAPER SEE DETAIL BELOW)

OPTION 2
TYPICAL TEMPORARY RAMP

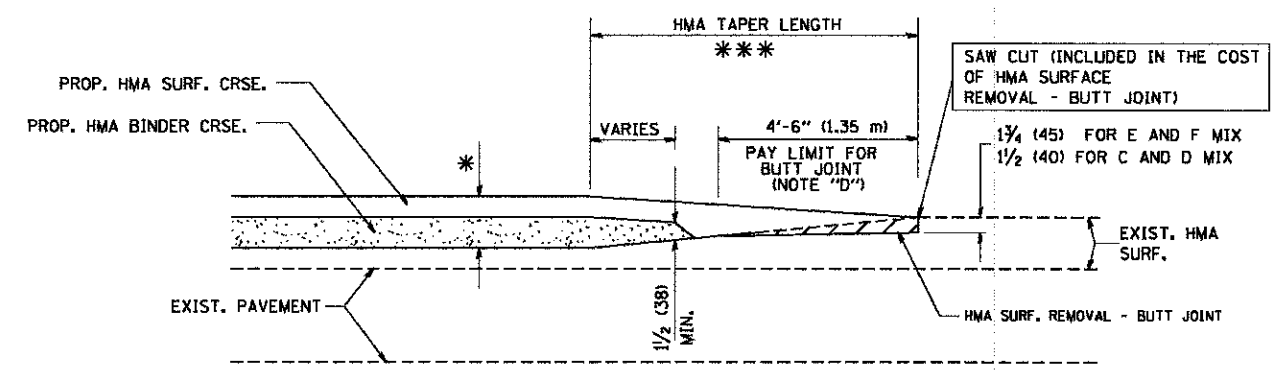

TYPICAL BUTT JOINT AND HMA TAPER
FOR MILLING AND RESURFACING

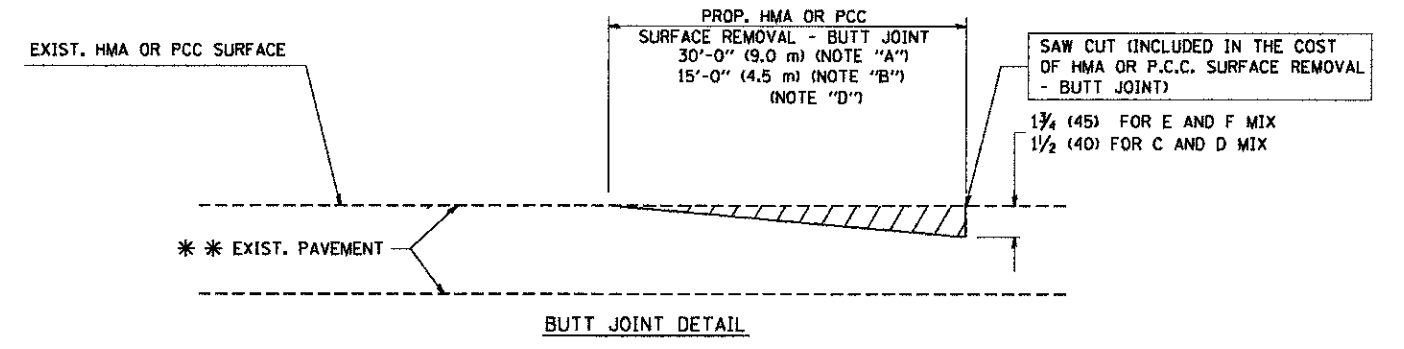

BUTT JOINT DETAIL

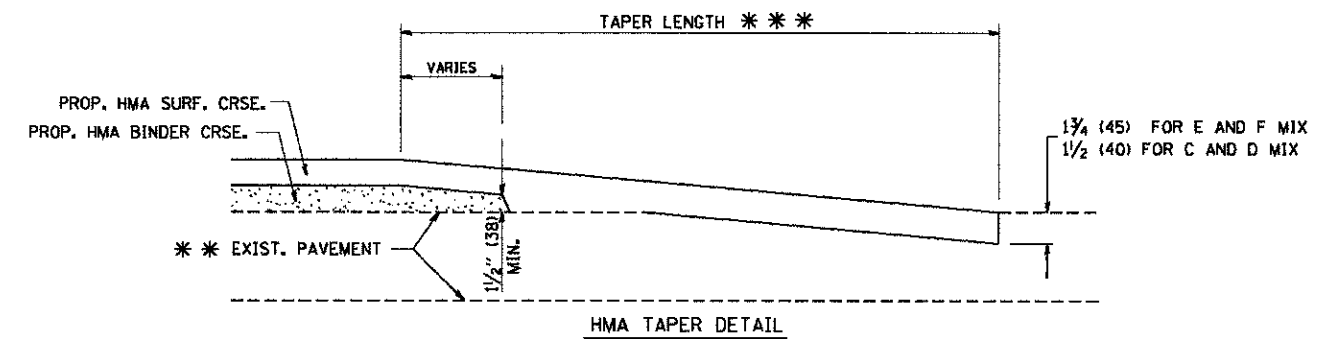

HMA TAPER DETAIL

TYPICAL BUTT JOINT AND HMA TAPER
FOR RESURFACING ONLY

*** PC CONCRETE, HMA OR HMA RESURFACED PAVEMENT.

NOTES

- A: MAINLINE ROADWAYS AND MAJOR SIDE ROADS.
 - B: MINOR SIDE ROADS.
 - C: THE TEMP. RAMP SHALL BE CONSTRUCTED IMMEDIATELY UPON REMOVAL OF THE EXISTING HMA SURFACE.
 - D: THE BUTT JOINT SHALL BE CONSTRUCTED IMMEDIATELY PRIOR TO PLACING THE PROPOSED HMA COURSES.
 - E: TAPER THE TEMP. RAMP AT A RATE OF 3'-0" (900 mm) PER 1 INCH (25 mm) OF MILLING THICKNESS.
 - F: INSTALLATION AND REMOVAL OF THE 4'-6" (1.35 m) TEMP. RAMP IS INCLUDED IN COST OF HMA SURFACE REMOVAL - BUTT JOINT
 - G: SEE ARTICLE 406.08 AND 406.14 OF THE STANDARD SPECIFICATIONS FOR "HMA AND/OR PCC SURFACE REMOVAL, BUTT JOINT".
- * SEE TYPICAL SECTIONS FOR MILLING THICKNESS.
- *** 20'-0" (6.1 m) PER 1 (25) RESURFACING (NOTE "A")
10'-0" (3.0 m) PER 1 (25) RESURFACING (NOTE "B")

BASIS OF PAYMENT:

THE BUTT JOINT WILL BE PAID FOR AT THE CONTRACT UNIT PRICE PER SQUARE YARD (SQUARE METER) FOR "HOT-MIX ASPHALT SURFACE REMOVAL - BUTT JOINT" OR FOR "PORTLAND CEMENT CONCRETE SURFACE REMOVAL - BUTT JOINT".

ALL DIMENSIONS ARE IN INCHES (MILLIMETERS) UNLESS OTHERWISE SHOWN.

FILE NAME = W:\data\22x34\bd32.dgn	USER NAME = gqjbenbt	DESIGNED - M. DE YONG	REVISED - R. SHAH 10-25-94	STATE OF ILLINOIS DEPARTMENT OF TRANSPORTATION	BUTT JOINT AND HMA TAPER DETAILS		F.A. STE.	SECTION	COUNTY	TOTAL SHEETS	SHEET NO.	
		DRAWN -	REVISED - A. ABBAS 03-21-97		100	11-00087-00-FP	COOK	164	131			
		PLOT SCALE = 5/8" = 1' IN.	REVISED - M. GOMEZ 04-06-01		SCALE: NONE		SHEET NO. 1 OF 1 SHEETS		STA. TO STA.		FED. ROAD DIST. NO. 1 ILLINOIS FED. AID PROJECT	
		PLOT DATE = 1/4/2009	REVISED - R. BORO 01-01-07		BD400-05 BD32		CONTRACT NO. 63770					

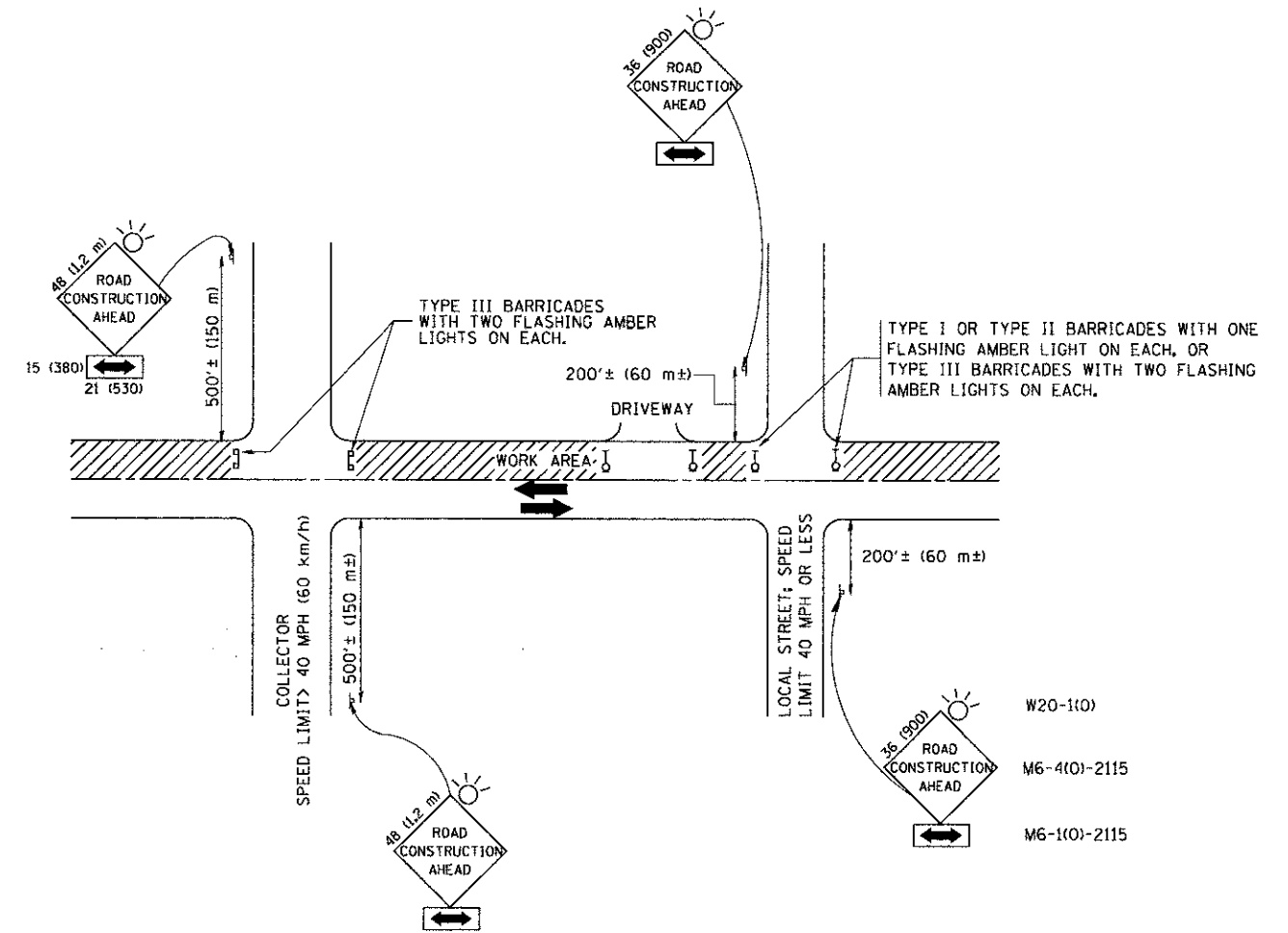

TRAFFIC CONTROL AND PROTECTION FOR SIDE ROADS, INTERSECTIONS, AND DRIVEWAYS

NOTES:

- A. FOR NO LANE RESTRICTION ON THE SIDE ROAD OR DRIVEWAYS
 1. SIDE ROAD WITH A SPEED LIMIT OF 40 MPH (60 km/h) OR LESS AS SHOWN ON THE DRAWING AND AS DIRECTED BY THE ENGINEER:
 - a) ONE ROAD CONSTRUCTION AHEAD SIGN 36 x 36 (900x900) WITH A FLASHER AND FLAG MOUNTED ON IT APPROXIMATELY 200' (60 m) IN ADVANCE OF THE MAIN ROUTE.
 - b) THE CLOSED PORTION OF THE MAIN ROUTE SHALL BE PROTECTED BY BLOCKING WITH TYPE I, TYPE II OR TYPE III BARRICADES, 1/3 OF THE CROSS SECTION OF THE CLOSED PORTION.
 2. SIDE ROAD WITH A SPEED LIMIT GREATER THAN 40 MPH (60 km/h) AS SHOWN ON THE DRAWING AND AS DIRECTED BY THE ENGINEER:
 - a) ONE ROAD CONSTRUCTION AHEAD SIGN 48 x 48 (1.2 m x 1.2 m) WITH A FLASHER MOUNTED ON IT APPROXIMATELY 500' (150 m) IN ADVANCE OF THE MAIN ROUTE.
 - b) THE CLOSED PORTION OF THE MAIN ROUTE SHALL BE PROTECTED BY BLOCKING WITH TYPE III BARRICADES, 1/2 OF THE CROSS SECTION OF THE CLOSED PORTION.
 3. WHEN THE SIDE ROAD LIES BETWEEN THE BEGINNING OF THE MAINLINE SIGNING AND THE WORK ZONE, A SINGLE HEADED ARROW (M6-1) SHALL BE USED IN LIEU OF THE DOUBLE HEADED ARROW (M6-4).
- B. FOR A LANE CLOSURE ON A SIDE ROAD OR DRIVEWAY:

USE APPLICABLE PORTIONS OF THE TYPICAL APPLICATION OF TRAFFIC CONTROL DEVICES (STD. 701501, STD. 701606 OR THE APPROPRIATE STANDARD). THE SPACING OF SIGNS AND BARRICADES SHALL BE ADJUSTED FOR FIELD CONDITIONS AS DIRECTED BY THE ENGINEER. THE DIRECTIONAL ARROW SHALL BE COVERED OR REMOVED WHEN NO LONGER CONSISTENT WITH THE SIDE ROAD LANE CLOSURE.
- C. ADVANCE WARNING SIGNS ARE TO BE OMITTED ON DRIVEWAY UNLESS OTHERWISE NOTED.
- D. THE TRAFFIC CONTROL AND PROTECTION FOR SIDE ROADS, INTERSECTIONS, AND DRIVEWAYS SHALL BE INCIDENTAL TO THE COST OF SPECIFIED TRAFFIC CONTROL STANDARDS OR ITEMS.

All dimensions are in millimeters (inches) unless otherwise shown.

FILE NAME = W:\dststd\22x34\1010.dgn	USER NAME = goglienobt	DESIGNED - LHA	REVISED - J. OBERLE 10-18-95
		DRAWN -	REVISED - A. HOUSEH 03-06-96
	PLOT SCALE = 50.000 1/16 IN.	CHECKED -	REVISED - A. HOUSEH 10-15-96
	PLOT DATE = 1/4/2008	DATE - 06-89	REVISED - T. RAMMACHER 01-06-00

STATE OF ILLINOIS
DEPARTMENT OF TRANSPORTATION

TRAFFIC CONTROL AND PROTECTION FOR
SIDE ROADS, INTERSECTIONS, AND DRIVEWAYS

SCALE: NONE SHEET NO. 1 OF 1 SHEETS STA. TO STA.

F.A. RTE.	SECTION	COUNTY	TOTAL SHEETS	SHEET NO.
1100	11-00067-00-FP	COOK	164	132
TC-10				CONTRACT NO. 63770
FED. ROAD DIST. NO. 1 ILLINOIS FED. AID PROJECT CMM 9003 (757)				

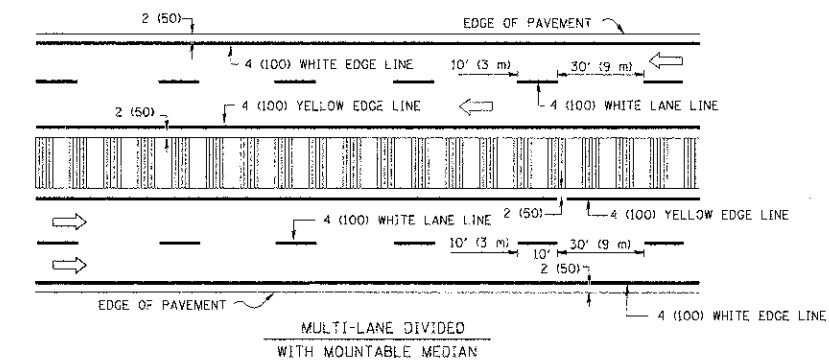
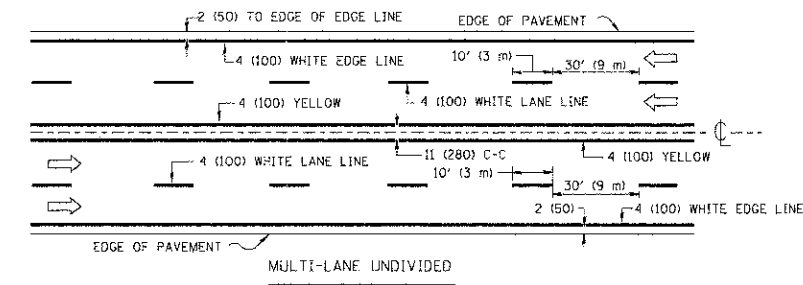
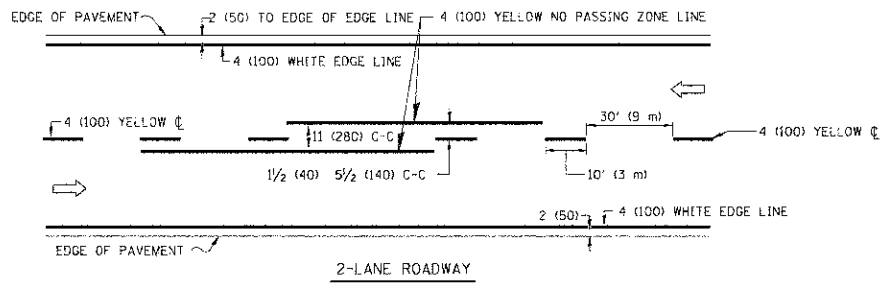

NOTE: MEDIANS WITH BARRIER CURB DO NOT REQUIRE AN EDGE LINE

TYPICAL LANE AND EDGE LINE MARKING

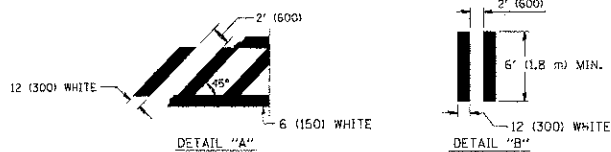
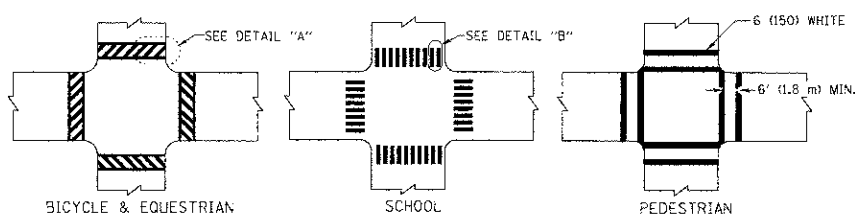

TYPICAL CROSSWALK MARKING

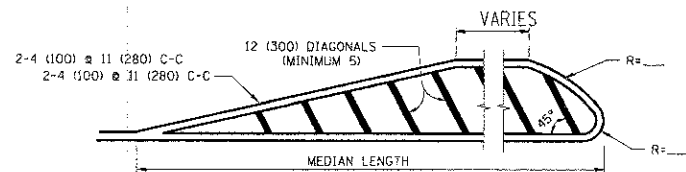
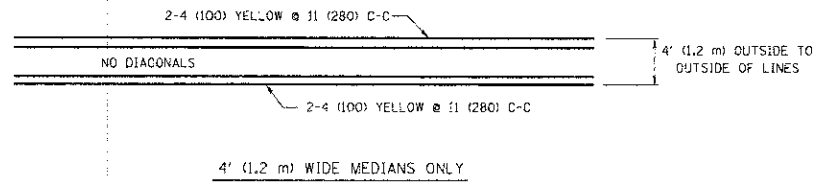

FOR MEDIAN LENGTHS WHERE DIAGONAL SPACING CANNOT BE ATTAINED, USE 5 (FIVE) EQUALLY SPACED DIAGONAL LINES.

DIAGONAL LINE SPACING: 50' (15 m) C-C (LESS THAN 30MPH (50 km/h))
75' (25 m) C-C 30MPH (50 km/h) TO 45MPH (70 km/h)
150' (45 m) C-C (MORE THAN 45MPH (70 km/h))

MEDIANS OVER 4' (1.2 m) WIDE

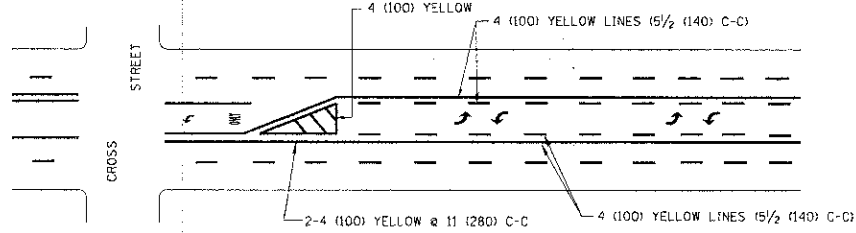

A MINIMUM OF TWO PAIRS OF TURN ARROWS SHALL BE USED, WHITE IN COLOR. ADDITIONAL PAIRS SHALL BE PLACED AT 200' (60 m) TO 300' (90 m) INTERVALS.

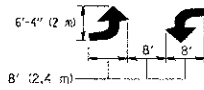

MEDIAN WITH TWO-WAY LEFT TURN LANE

TYPICAL PAINTED MEDIAN MARKING

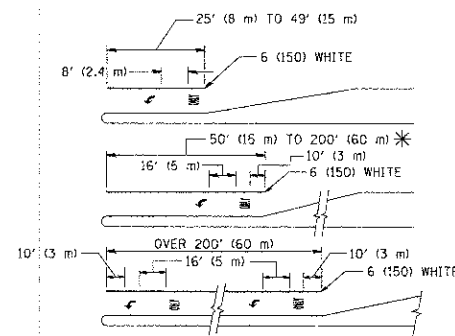

FULL SIZE LETTERS 8' (2.4 m) AND ARROWS SHALL BE USED.
AREA = 15.6 SQ. FT. (1.5 m²) ONLY AREA = 20.8 SQ. FT. (1.9 m²)

* TURN LANES IN EXCESS OF 400' (120 m) IN LENGTH MAY HAVE AN ADDITIONAL SET OF ARROW - "ONLY" INSTALLED MIDWAY BETWEEN THE OTHER TWO SETS OF ARROW - "ONLY".

TYPICAL LEFT (OR RIGHT) TURN LANE

TYPICAL TURN LANE MARKING

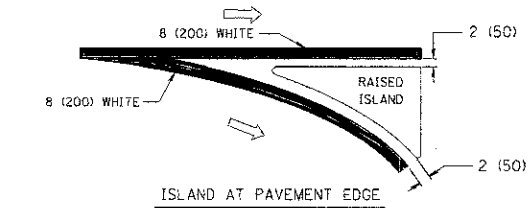
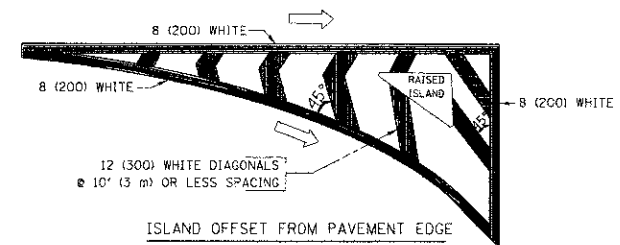

TYPICAL ISLAND MARKING

TYPE OF MARKING	WIDTH OF LINE	PATTERN	COLOR	SPACING / REMARKS
CENTERLINE ON 2 LANE PAVEMENT	4 (100)	SKIP-DASH	YELLOW	10' (3 m) LINE WITH 30' (9 m) SPACE
CENTERLINE ON MULTI-LANE UNDIVIDED PAVEMENT	2 @ 4 (100)	SOLID	YELLOW	11 (280) C-C
NO PASSING ZONE LINES: FOR ONE DIRECTION	4 (100)	SOLID	YELLOW	5/2 (140) C-C FROM SKIP-DASH CENTERLINE
NO PASSING ZONE LINES: FOR BOTH DIRECTIONS	2 @ 4 (100)	SOLID	YELLOW	11 (280) C-C OMIT SKIP-DASH CENTERLINE BETWEEN
LANE LINES	4 (100)	SKIP-DASH	WHITE	10' (3 m) LINE WITH 30' (9 m) SPACE
LANE LINES	5 (125) ON FREEWAYS	SKIP-DASH	WHITE	
DOTTED LINES (EXTENSIONS OF CENTER, LANE OR TURN LANE MARKINGS)	SAME AS LINE BEING EXTENDED	SKIP-DASH	SAME AS LINE BEING EXTENDED	2' (600) LINE WITH 6' (1.8 m) SPACE
EDGE LINES	4 (100)	SOLID	YELLOW-LEFT WHITE-RIGHT	OUTLINE MOUNTABLE MEDIANS IN YELLOW; EDGE LINES ARE NOT USED NEXT TO BARRIER CURB
TURN LANE MARKINGS	6 (150) LINE; FULL SIZE LETTERS & SYMBOLS (8' (2.4m))	SOLID	WHITE	SEE TYPICAL TURN LANE MARKING DETAIL
TWO WAY LEFT TURN MARKING	2 @ 4 (100) EACH DIRECTION	SKIP-DASH AND SOLID	YELLOW	10' (3 m) LINE WITH 30' (9 m) SPACE FOR SKIP-DASH; 5/2 (140) C-C BETWEEN SOLID LINE AND SKIP-DASH LINE
TWO WAY LEFT TURN MARKING	8' (2.4m) LEFT ARROW	IN PAIRS	WHITE	SEE TYPICAL TWO-WAY LEFT TURN MARKING DETAIL
CROSSWALK LINES (PEDESTRIAN) A. DIAGONALS (BIKE & EQUESTRIAN) B. LONGITUDINAL BARS (SCHOOL)	2 @ 6 (150) 12 (300) @ 45° 12 (300) @ 90°	SOLID SOLID SOLID	WHITE WHITE WHITE	NOT LESS THAN 6' (1.8 m) APART 2' (600) APART SEE TYPICAL CROSSWALK MARKING DETAILS.
STOP LINES	24 (600)	SOLID	WHITE	PLACE < 11.2 m IN ADVANCE OF AND PARALLEL TO CROSSWALK, IF PRESENT. OTHERWISE, PLACE AT DESIRED STOPPING POINT, PARALLEL TO CROSSROAD CENTERLINE, WHERE POSSIBLE
PAINTED MEDIANS	2 @ 4 (100) WITH 12 (300) DIAGONALS @ 45° NO DIAGONALS USED FOR 4' (1.2 m) WIDE MEDIANS	SOLID	YELLOW: TWO WAY TRAFFIC WHITE: ONE WAY TRAFFIC	11 (280) C-C FOR THE DOUBLE LINE SEE TYPICAL PAINTED MEDIAN MARKING.
GORE MARKING AND CHANNELIZING LINES	8 (200) WITH 12 (300) DIAGONALS @ 45°	SOLID	WHITE	DIAGONALS: 15' (4.5 m) C-C (LESS THAN 30MPH (50 km/h)) 20' (6 m) C-C 30MPH (50 km/h) TO 45MPH (70 km/h) 30' (9 m) C-C (OVER 45MPH (70 km/h))
RAILROAD CROSSING	24 (600) TRANSVERSE LINES; "RR" IS 6' (1.8 m) LETTERS; 16 (400) LINE FOR "X"	SOLID	WHITE	SEE STATE STANDARD 780001 AREA OF: "R"=3.6 SQ. FT. (0.33 m ²) EACH "X"=54.0 SQ. FT. (5.0 m ²)
SHOULDER DIAGONALS	12 (300) @ 45°	SOLID	WHITE - RIGHT YELLOW - LEFT	50' (15 m) C-C (LESS THAN 30MPH (50 km/h)) 75' (25 m) C-C (30 MPH (50 km/h) TO 45MPH (70 km/h)) 150' (45 m) C-C (OVER 45MPH (70 km/h))

FOR FURTHER DETAILS ON PAVEMENT MARKING REFER TO STANDARD SPECIFICATIONS FOR ROAD AND BRIDGE CONSTRUCTION AND STATE STANDARD 780001.

All dimensions are in inches (millimeters) unless otherwise shown.

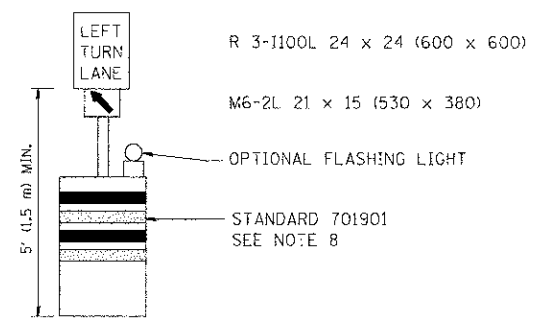
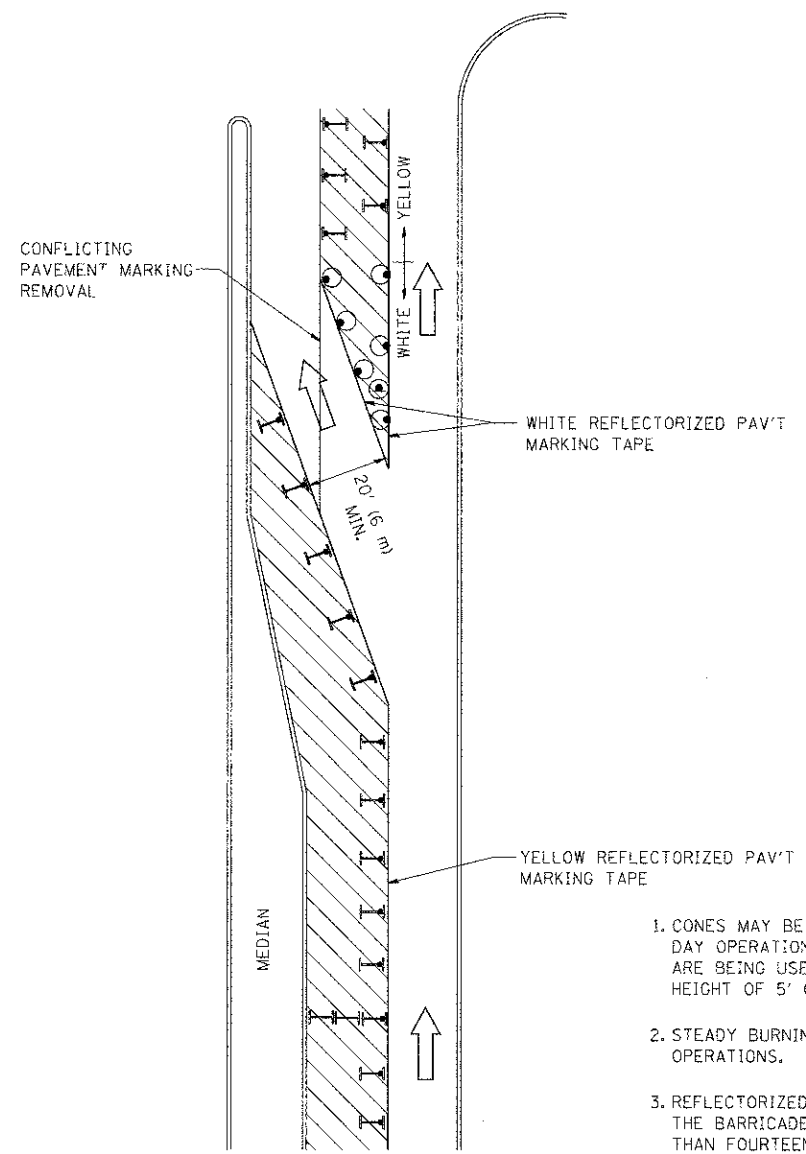





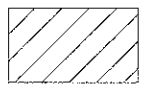

GENERAL NOTES

1. CONES MAY BE SUBSTITUTED FOR BARRICADES OR DRUMS AT HALF THE SPACING DURING DAY OPERATIONS. CONES SHALL BE A MINIMUM OF 28 (710) IN HEIGHT. WHEN CONES ARE BEING USED, THE "LEFT TURN LANE" SIGN MAY BE SKID MOUNTED AT A MINIMUM HEIGHT OF 5' (1.5 m).
2. STEADY BURNING LIGHTS WILL NOT BE REQUIRED ON BARRICADES OR DRUMS FOR DAY OPERATIONS. ALL LIGHTS SHALL BE MONODIRECTIONAL.
3. REFLECTORIZED TEMPORARY PAVEMENT MARKING TAPE SHALL BE PLACED THROUGHOUT THE BARRICADED AREA OF EACH TURN BAY WHERE THE CLOSURE TIME IS GREATER THAN FOURTEEN DAYS.
4. THIS APPLICATION ALSO APPLIES WHEN WORK IS BEING PERFORMED IN THE RIGHT LANE(S) AND THE RIGHT TURN BAY IS TO REMAIN OPEN. UNDER THIS CONDITION, "RIGHT TURN LANE" R3-100 24 x 24 (600 x 600) AND M6-2R 21 x 15 (530 x 380) SHALL BE USED.
5. THESE CONTROLS SHALL SUPPLEMENT MAINLINE TRAFFIC CONTROL FOR LANE CLOSURES.
6. LONGITUDINAL DIMENSIONS MAY BE ADJUSTED TO FIT FIELD CONDITIONS.
7. FORM OPER 725 IS REQUIRED.
8. IF A DRUM OR TYPE II BARRICADE WITH AN ATTACHED SIGN PANEL WHICH MEETS NCHRP 350 REQUIREMENTS IS NOT AVAILABLE, THE SIGNS SHALL BE MOUNTED, ABOVE THE BARRICADES, ON SEPARATE SIGNS SUPPORTS THAT MEET NCHRP 350 REQUIREMENTS.
9. TRAFFIC CONTROL AND PROTECTION AT TURN BAYS (TO REMAIN OPEN TO TRAFFIC) SHALL BE INCLUDED IN THE COST SPECIFIED TRAFFIC CONTROL STANDARDS OR ITEMS.

All dimensions are in inches (millimeters) unless otherwise shown.

LEGEND

-  WORK AREA
-  LANE OPEN TO TRAFFIC
-  TYPE I OR II BARRICADE WITH STEADY BURN LIGHT
-  DRUM WITH STEADY BURN LIGHT
-  DRUM WITH SIGN (WITH OPTIONAL FLASHING LIGHT) SEE DETAIL
-  TYPE I OR II CHECK BARRICADE WITH FLASHING LIGHT

FILE NAME =	USER NAME = drvakosgn	REVISED - T. RAMMACHER 09-08-94	REVISED - R. BORO 09-14-09
6:\work\p1001\DRIVAKOSGN\0108351\14.dgn		REVISED - A. HOUSEH 11-07-95	REVISED -
	PLOT SCALE = 48.9999 / IN.	REVISED - A. HOUSEH 10-12-96	REVISED -
	PLOT DATE = 9/14/2009	REVISED - T. RAMMACHER 01-06-00	REVISED -

**STATE OF ILLINOIS
DEPARTMENT OF TRANSPORTATION**

**TRAFFIC CONTROL AND PROTECTION AT TURN BAYS
(TO REMAIN OPEN TO TRAFFIC)**

SCALE: NONE SHEET NO. 1 OF 1 SHEETS STA. TO STA.

F.A. RTE.	SECTION	COUNTY	TOTAL SHEETS	SHEET NO.
1100	11-00087-00-EP	COOK	164	134
TC-14			CONTRACT NO. 63770	
FED. ROAD DIST. NO. 1 ILLINOIS FED. AID PROJECT CMM 9003 (757)				

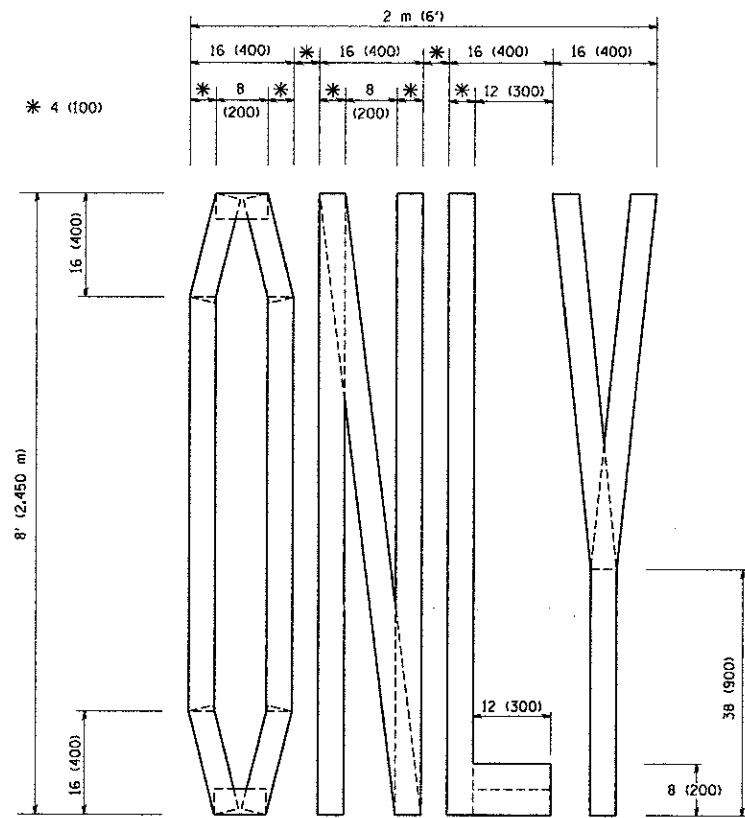

QUANTITY
 4 (100) LINE = 64.1 ft. (19.7 m)
 21.1 sq. ft. (1.97 sq. m)

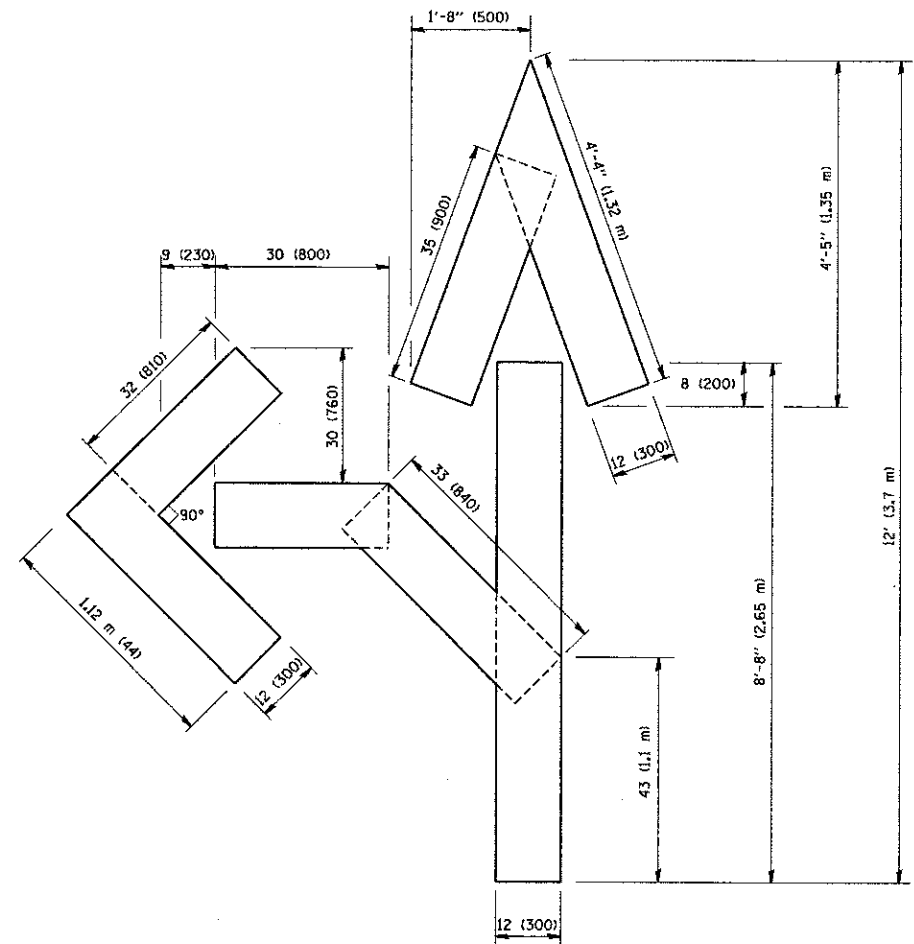

QUANTITY
 4 (100) LINE = 82.5 ft. (25.3 m)
 27.5 sq. ft. (2.53 sq. m)

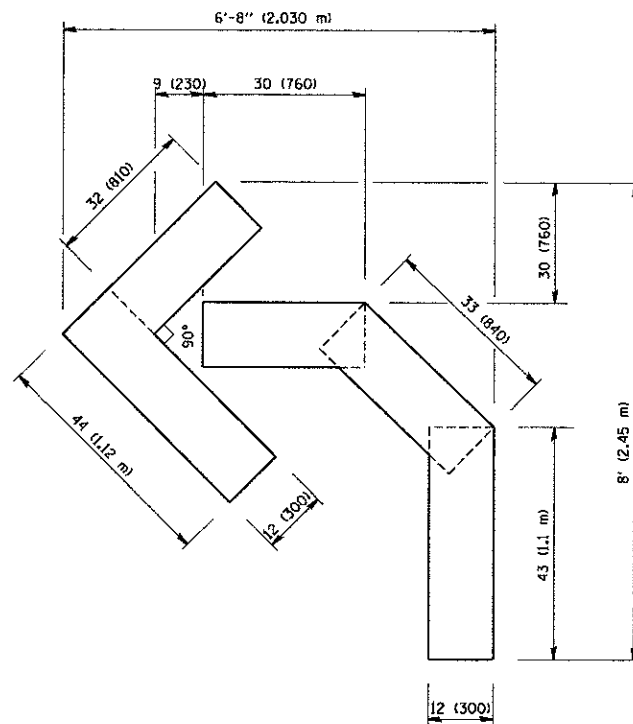

QUANTITY
 4 (100) LINE = 45.5 ft. (13.9 m)
 15.2 sq. ft. (1.39 sq. m)

All dimensions are in inches (millimeters) unless otherwise shown.

FILE NAME =	USER NAME = geglrenobt	DESIGNED -	REVISED - T. RAMMACHER 06-05-96
W:\d\stsd\22x34\tp16.dgn		DRAWN -	REVISED - T. RAMMACHER 11-04-97
		CHECKED -	REVISED - T. RAMMACHER 03-02-98
		DATE - 09-18-94	REVISED - E. GOMEZ 08-28-00

STATE OF ILLINOIS
 DEPARTMENT OF TRANSPORTATION

PAVEMENT MARKING LETTERS AND SYMBOLS
 FOR TRAFFIC STAGING

SCALE: NONE SHEET NO. 1 OF 1 SHEETS STA. TO STA.

F.A. RTE.	SECTION	COUNTY	TOTAL SHEETS	SHEET NO.
1100	11-00087-00-FP	COOK	184	135
TC-16			CONTRACT NO. 63770	
FED. ROAD DIST. NO. 1 ILLINOIS FED. AID PROJECT CMM 9003 (757)				

ROUTE MARKERS

 FOR U.S. ROUTES
M1-40-2424

 FOR ILLINOIS ROUTES
M1-50-2424

 R.R. UNMARKED ROUTES
SPECIAL 24" x 18" VARIABLE
4" BLACK LETTERS ON WHITE
REFLECTIVE BACKGROUND

ARROWS SIGNS

 M5-1L-2115

 M5-1R-2115

 M6-1-2115

 M6-2-2115

 M6-3-2115

CARDINAL DIRECTION & DETOUR SIGNS

 NORTH M3-1-2412

 EAST M3-2-2412

 SOUTH M3-3-2412

 WEST M3-4-2412

 DETOUR M4-8-2412

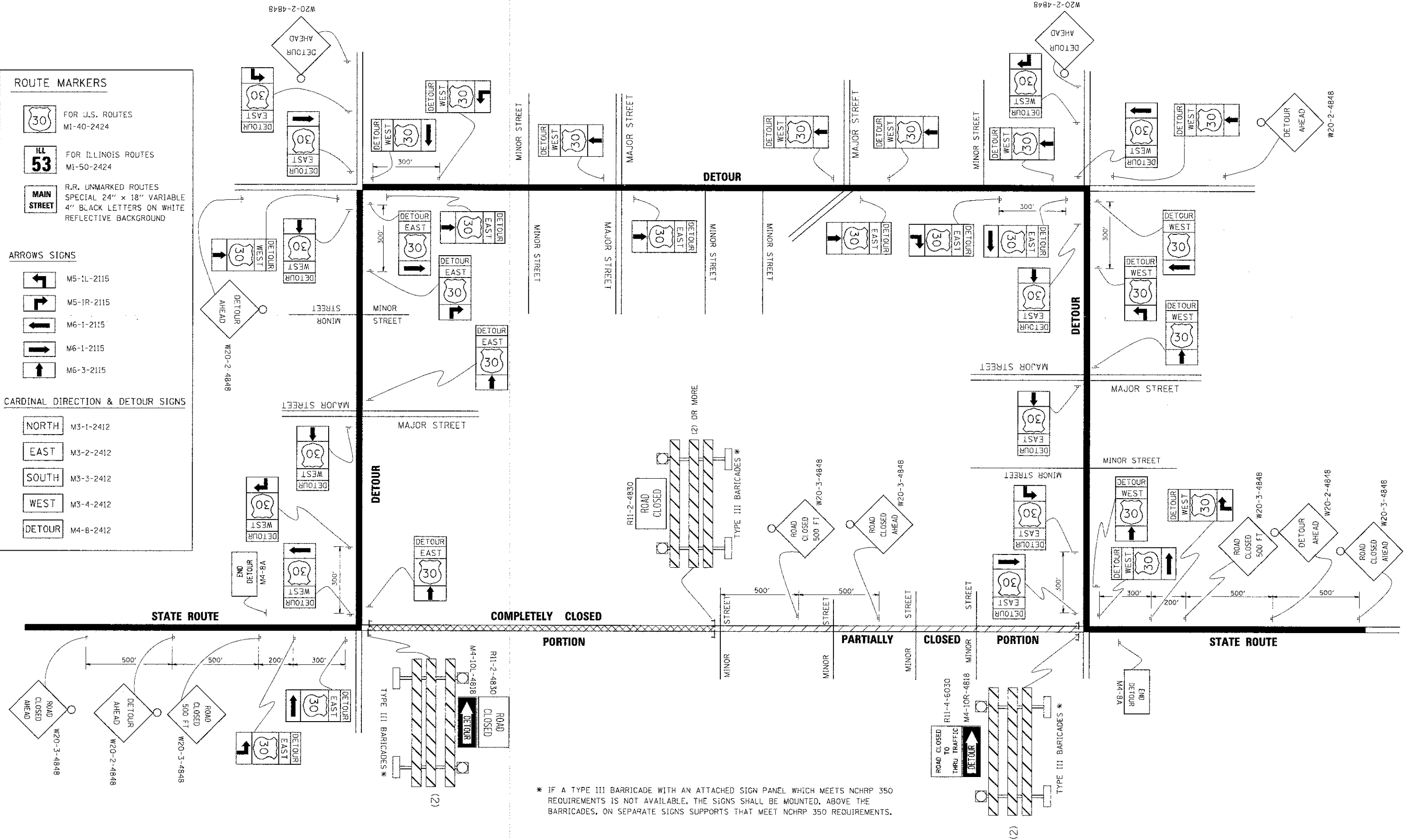

* IF A TYPE III BARRICADE WITH AN ATTACHED SIGN PANEL WHICH MEETS NCHRP 350 REQUIREMENTS IS NOT AVAILABLE, THE SIGNS SHALL BE MOUNTED, ABOVE THE BARRICADES, ON SEPARATE SIGNS SUPPORTS THAT MEET NCHRP 350 REQUIREMENTS.

FILE NAME =	USER NAME = drivakosgn	DESIGNED -	REVISED - 10-18-02
c:\pwwork\pwwork\DOT\DRIVAKOSGN\d0188315\21.dgn		DRAWN -	REVISED - R. BORO 09-14-09
	PLOT SCALE = 1/4" = 1' IN.	CHECKED -	REVISED -
	PLOT DATE = 9/14/2009	DATE -	REVISED -

**STATE OF ILLINOIS
DEPARTMENT OF TRANSPORTATION**

DETOUR SIGNING FOR CLOSING STATE HIGHWAYS			
SCALE: NONE	SHEET NO. 1 OF 1 SHEETS	STA.	TO STA.

F.A. RTE.	SECTION	COUNTY	TOTAL SHEETS	SHEET NO.
1100	11-00087-00-PP	COOK	164	136
TC-21		CONTRACT NO. 6377C		
FED. ROAD DIST. NO. 1 ILLINOIS FED. AID PROJECT CMM 9003 (757)				

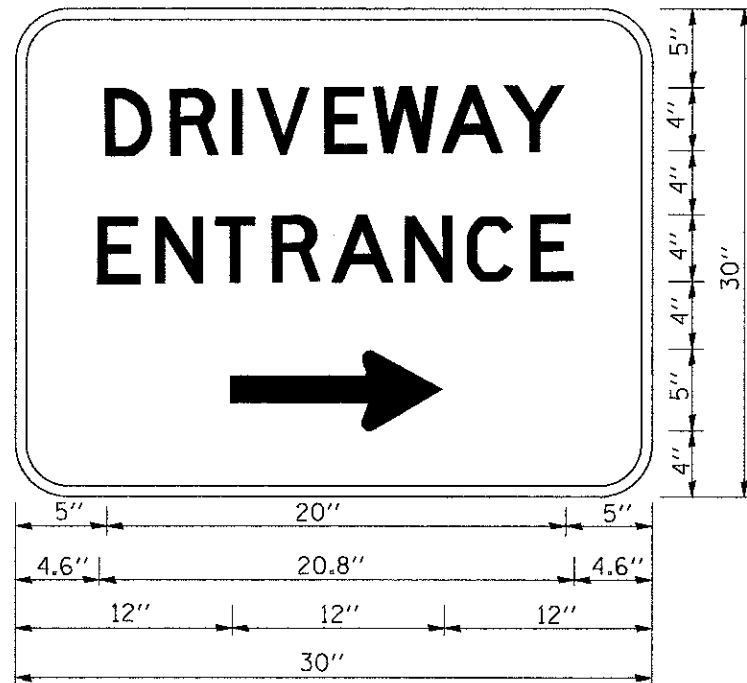

3.0" RADIUS, 0.5" BORDER, WHITE ON GREEN; REFLECTORIZED
 "DRIVEWAY" D; "ENTRANCE" D; STANDARD ARROW CUSTOM 12.0" x 5.0"

NOTES:

1. HALF OF THE SIGNS WILL REQUIRE A LEFT HAND FACING ARROW.
2. TWO SIGNS SHALL BE USED AT EACH COMMERCIAL ENTRANCE PLACED BACK-TO-BACK: ONE WITH A RIGHT HAND ARROW (SHOWN) SHALL BE PLACED ON THE NEAR RIGHT SIDE THE DRIVEWAY AND ONE WITH A LEFT HAND ARROW SHALL BE PLACED ON THE FAR LEFT SIDE OF THE DRIVEWAY.
3. SIGNS TO BE PAID FOR AS ITEM "TEMPORARY INFORMATION SIGNING".

FILE NAME =
 W:\dstatd\22x34\tc26.dgn

USER NAME = gagl1enob1

DESIGNED -

DRAWN -

CHECKED -

DATE -

REVISED - C. JUCIUS 02-15-07

REVISED -

REVISED -

REVISED -

STATE OF ILLINOIS
 DEPARTMENT OF TRANSPORTATION

DRIVEWAY ENTRANCE SIGNING

SCALE: NONE SHEET NO. 1 OF 1 SHEETS STA. TO STA.

F.A. RTE.	SECTION	COUNTY	TOTAL SHEETS	SHEET NO.
1100	11-00087-00-FP	COOK	164	137
TC-26			CONTRACT NO. 63770	
FED. ROAD DIST. NO. 1 ILLINOIS FED. AID PROJECT CMM 9003 (757)				

PLAN	SURVEYED	DATE	BY	DATE
NOTE BOOK NO.	FLIPPED			
	ALIGNED			
	AS SHOWN			
	CHECKED			
	DATE			
	BY			

PROFILE	SURVEYED	DATE	BY	DATE
NOTE BOOK NO.	FLIPPED			
	ALIGNED			
	AS SHOWN			
	CHECKED			
	DATE			
	BY			

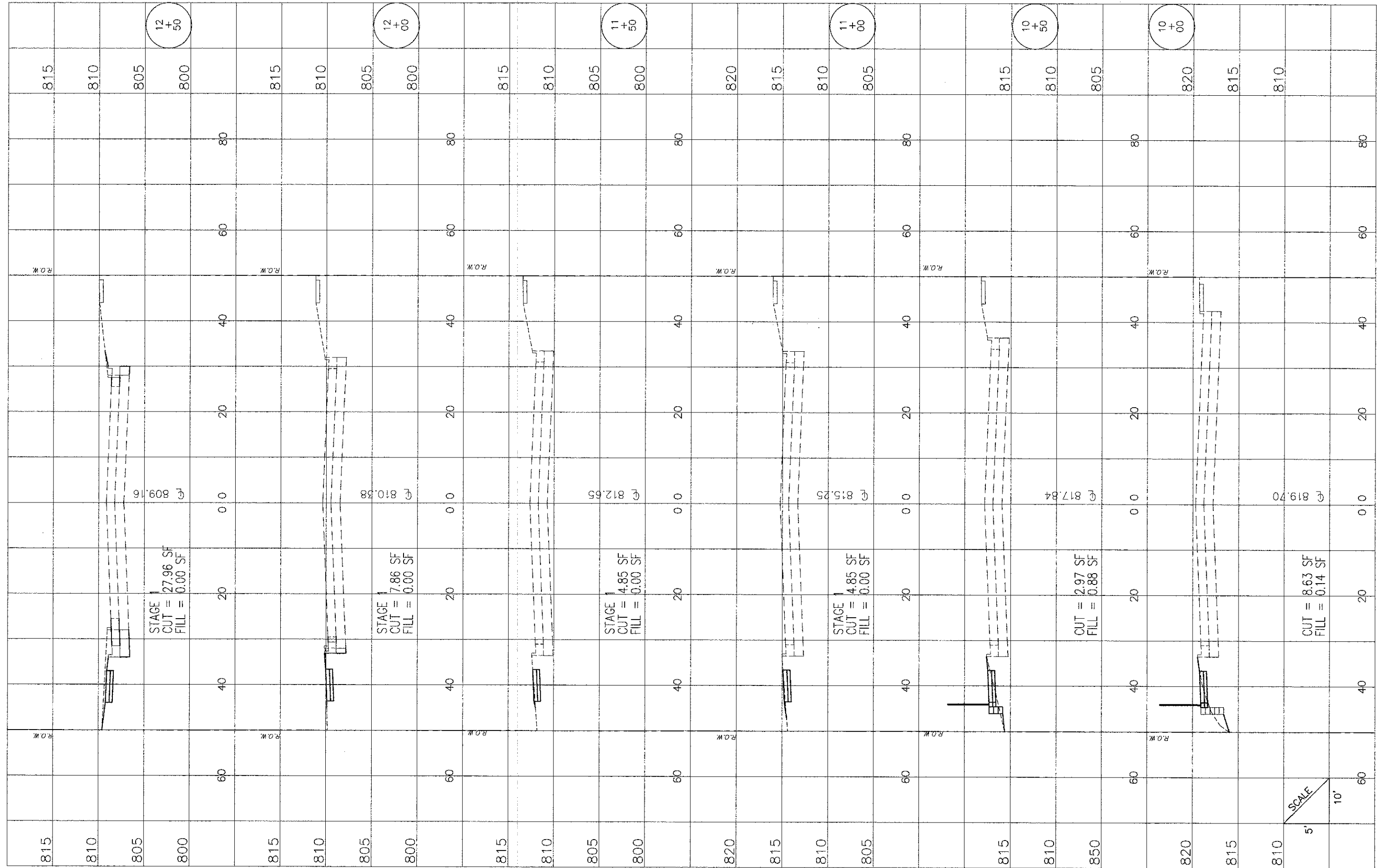

HASSELL ROAD

FILE NAME - Hassell Plan-Profile.dwg

DESIGNED -	REVISED -
DRAWN -	REVISED -
CHECKED -	REVISED -
DATE -	REVISED -

STATE OF ILLINOIS
DEPARTMENT OF TRANSPORTATION

Hassell Road STP Project
Cross Sections

SHEET NO. 1 OF 27 SHEETS STA. 10+00 TO STA 12+50

F.A.U. R.T.E.	SECTION	COUNTY	TOTAL SHEETS	SHEET NO.
1100	11-00087-00-FP	Cook	164	138
CONTRACT NO. 63770			ILLINOIS FED. AID PROJECT CMM 9003(757)	

SCALE
5'
10'

PLAN	SURVEYED	NOTED	CHECKED
NO.	NO.	NO.	NO.

PROFILE	DATE	BY	DATE
NO.			

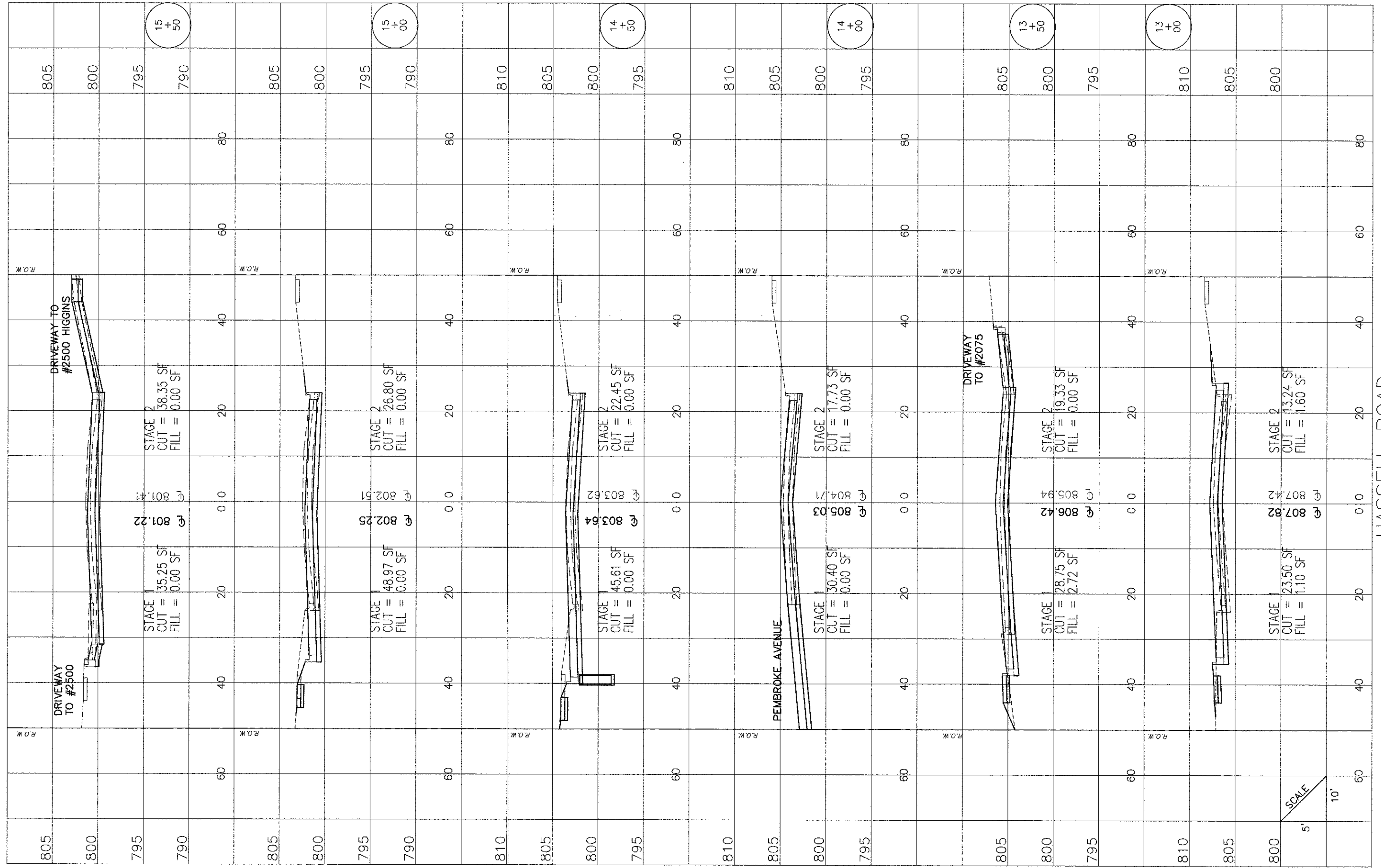

FILE NAME = Hassell Plan-Profile.dwg

DESIGNED -	REVISED -
DRAWN -	REVISED -
CHECKED -	REVISED -
DATE -	REVISED -

STATE OF ILLINOIS
DEPARTMENT OF TRANSPORTATION

Hassell Road STP Project
Cross Sections

SHEET NO. 2 OF 27 SHEETS STA. 13+00 TO STA 15+50

F.A.U. RTE.	SECTION	COUNTY	TOTAL SHEETS	SHEET NO.
1100	11-00087-00-FP	Cook	164	139
CONTRACT NO. 63770			ILLINOIS FED. AID PROJECT CMM 9003(757)	

SCALE
5' 10'

HASSELL ROAD

PLAN	SURVEYED	NOTED	CHECKED
NO.	NO.	BY	DATE

PROFILE	DATE	BY
NO.		

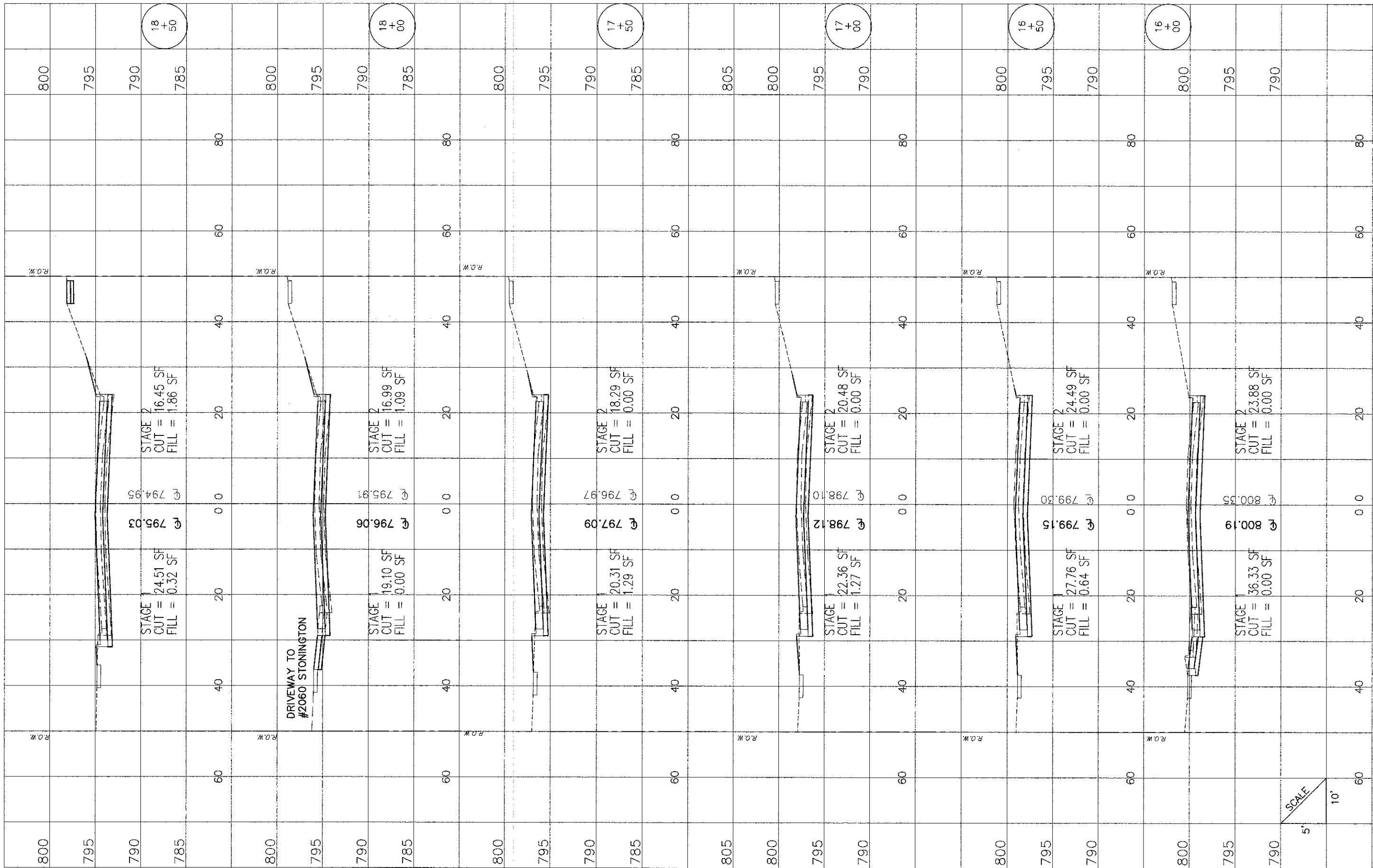

HASSELL ROAD

FILE NAME - Hassell Plan-Profile.dwg

DESIGNED -	REVISOR -
DRAWN -	REVISOR -
CHECKED -	REVISOR -
DATE -	REVISOR -

DESIGNED -	REVISOR -
DRAWN -	REVISOR -
CHECKED -	REVISOR -
DATE -	REVISOR -

STATE OF ILLINOIS
DEPARTMENT OF TRANSPORTATION

Hassell Road STP Project
Cross Sections

SHEET NO. 3 OF 27 SHEETS STA. 16+00 TO STA 18+50

F.A.U. RTE. 1100	SECTION 11-00087-00-FP	COUNTY Cook	TOTAL SHEETS 164	SHEET NO. 140
CONTRACT NO. 63770			ILLINOIS FED. AID PROJECT CMM 9003(757)	

SCALE
5' 10'

PLAN	REVISION	DATE
NOTE BOOK	ALIGNED	CHECKED
NO.	NO.	NO.

PROFILE	DATE	BY
NOTE BOOK	CHECKED	
NO.	NO.	

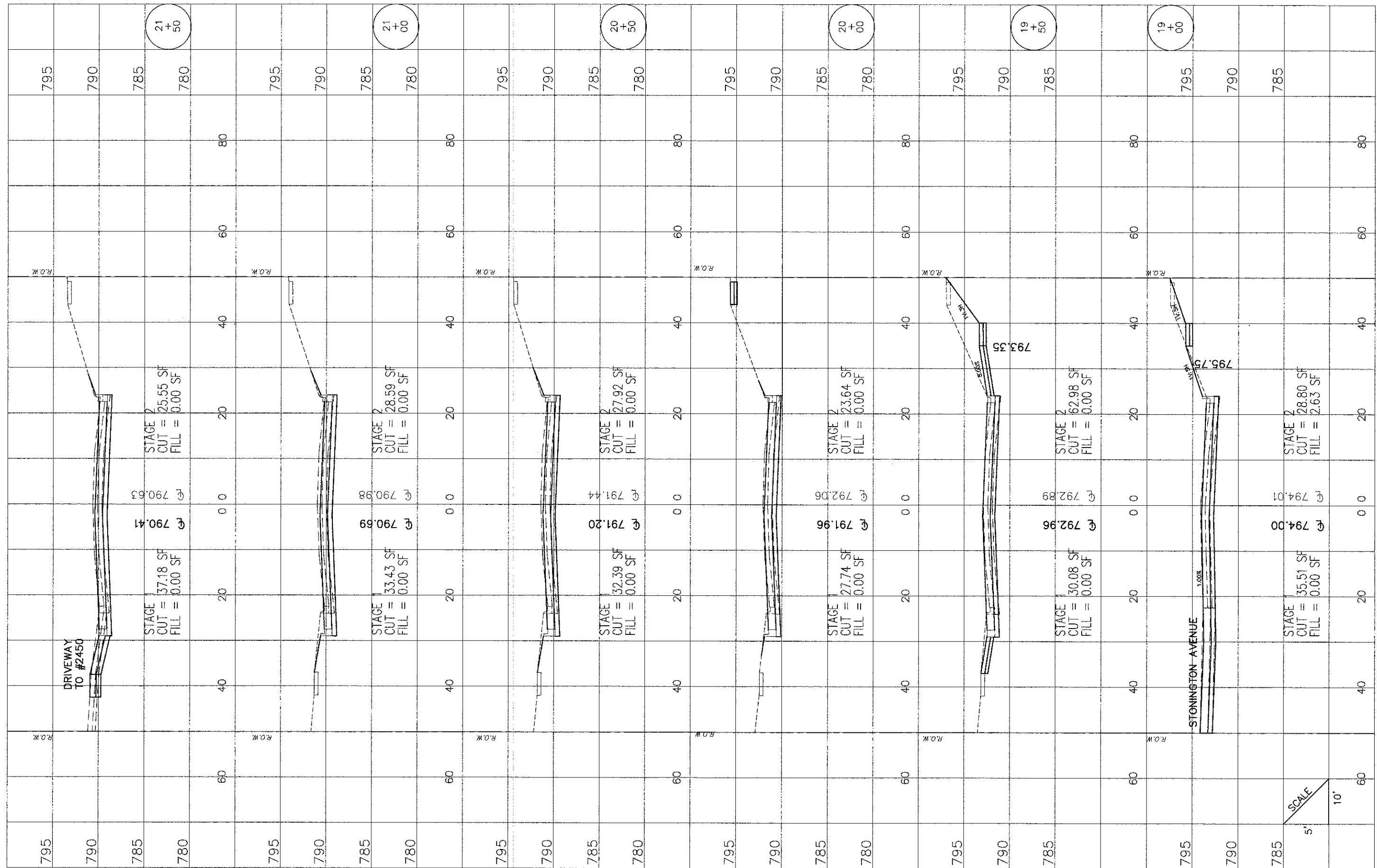

FILE NAME - Hassell Plan-Profile.dwg

DESIGNED -
 DRAWN -
 CHECKED -
 DATE -

**STATE OF ILLINOIS
 DEPARTMENT OF TRANSPORTATION**

**Hassell Road STP Project
 Cross Sections**

SHEET NO. 4 OF 27 SHEETS STA. 19+00 TO STA 21+50

F.A.U. RTE.	SECTION	COUNTY	TOTAL SHEETS	SHEET NO.
1100	11-00087-00-PP	Cook	164	141
CONTRACT NO. 63770			ILLINOIS FED. AID PROJECT CMM 9003(757)	

PLAN	DRAWN	CHECKED
NO.	BY	DATE
NOTE BOOK NO. OF WAY CHECKED		
PROFILE NAME		

PROFILE	DATE	BY
NO.	DATE	BY
NOTE BOOK GRADES CHECKED		
STRUCTURE NOTINGS CHD		

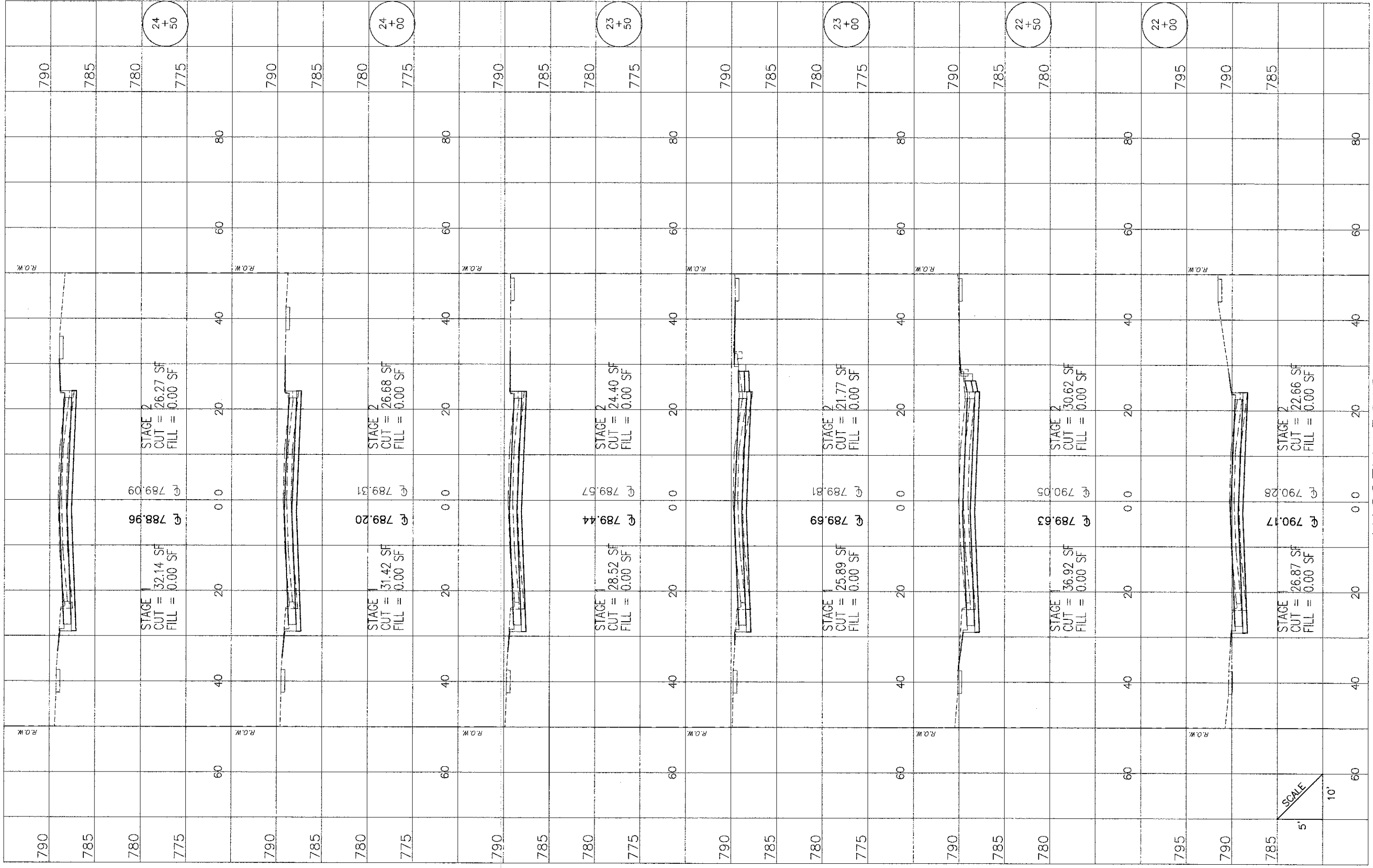

HASSELL ROAD

FILE NAME --
Hassell Plan-Profile.dwg

DESIGNED -	REVISED -
DRAWN -	REVISED -
CHECKED -	REVISED -
DATE -	REVISED -

STATE OF ILLINOIS
DEPARTMENT OF TRANSPORTATION

Hassell Road STP Project
Cross Sections

SHEET NO. 5 OF 27 SHEETS STA. 22+00 TO STA. 24+50

F.A.U. RTE.	SECTION	COUNTY	TOTAL SHEETS	SHEET NO.
1100	11-00087-00-FP	Cook	164	142
CONTRACT NO. 63770			ILLINOIS FED. AID PROJECT CMM 9003(757)	

PLAN	SURVEYED	DATE	BY
NOTE BOOK	ALIGNED	CHECKED	NO.
	CAUTION	DATE	
	NAME		

PROFILE	SURVEYED	DATE	BY
NOTE BOOK	ALIGNED	CHECKED	NO.
	CAUTION	DATE	
	NAME		

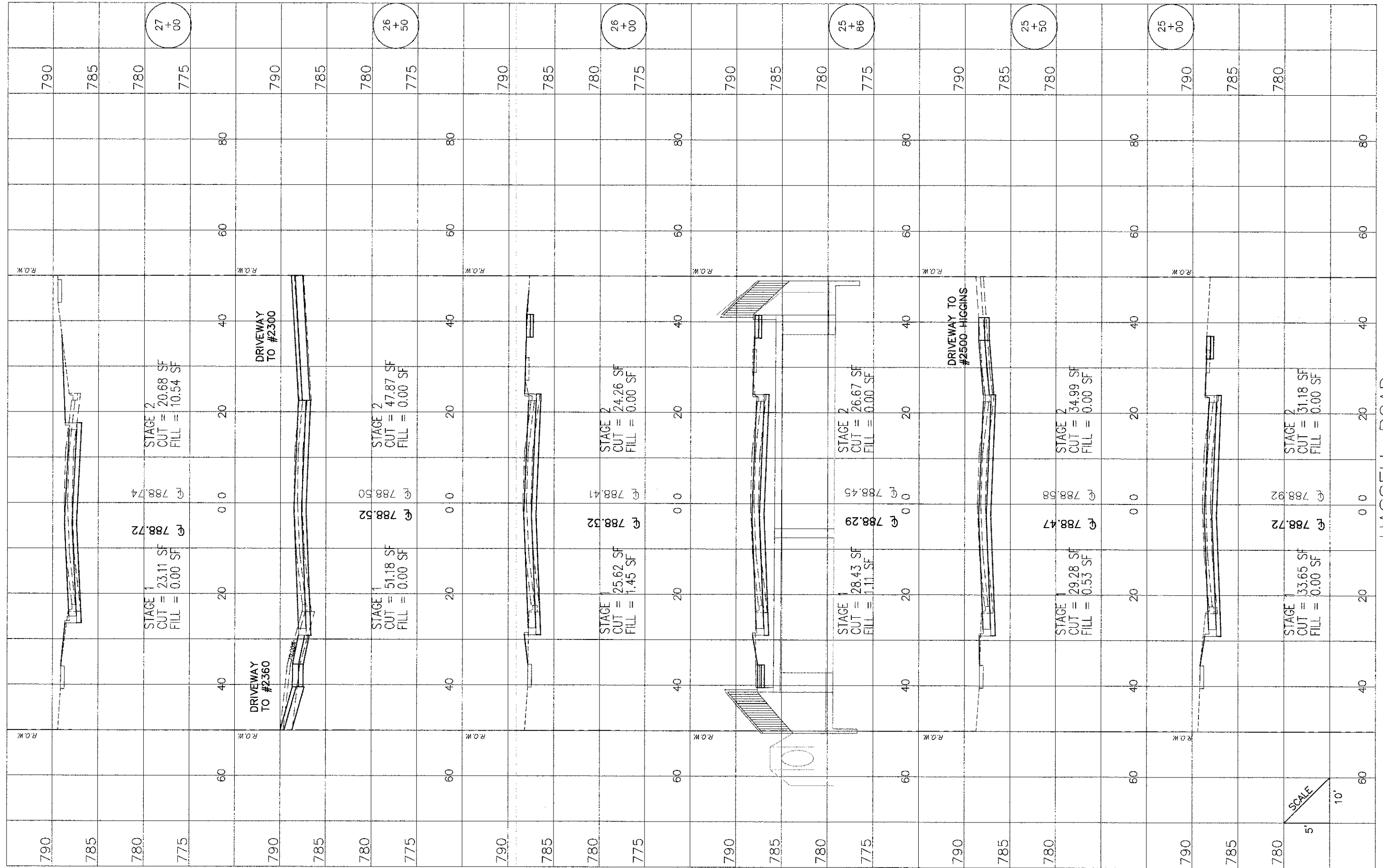

HASSELL ROAD

SCALE
5' 10'

FILE NAME -	DESIGNED -
Hassell Plan-Profile.dwg	DRAWN -
	CHECKED -
	DATE -

REVISOR	REVISION

STATE OF ILLINOIS
DEPARTMENT OF TRANSPORTATION

Hassell Road STP Project
Cross Sections
SHEET NO. 6 OF 27 SHEETS STA. 25+00 TO STA 27+00

F.A.U. RTE.	SECTION	COUNTY	TOTAL SHEETS	SHEET NO.
1100	11-00087-00-FP	Cook	164	143
CONTRACT NO. 63770			ILLINOIS FED. AID PROJECT CMM 9003(757)	

PLAN	SURVEYED	DATE	BY
	ALIGNED		
	CHECKED		
	DATE		
	BY		
	NO.		

PROFILE	SURVEYED	DATE	BY
	ALIGNED		
	CHECKED		
	DATE		
	BY		
	NO.		

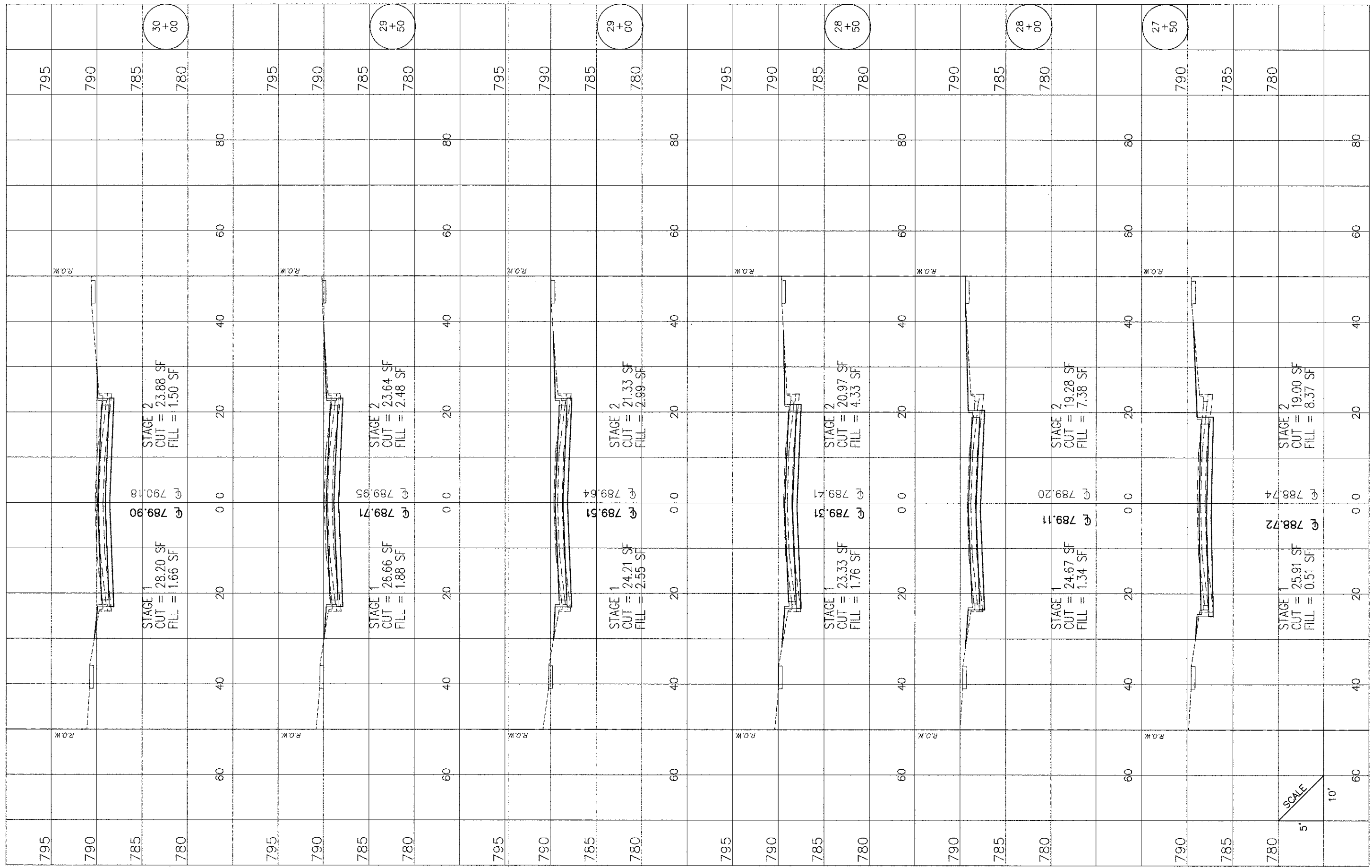

HASSELL ROAD

FILE NAME = Hassell Plan-Profile.dwg

DESIGNED -	REVISED -
DRAWN -	REVISED -
CHECKED -	REVISED -
DATE -	REVISED -

STATE OF ILLINOIS
DEPARTMENT OF TRANSPORTATION

Hassell Road STP Project
Cross Sections

SHEET NO. 7 OF 27 SHEETS STA. 27+50 TO STA 30+00

F.A.U. RTE	SECTION	COUNTY	TOTAL SHEET SHEETS NO.
1100	11-00087-00-FP	Cook	164 144
CONTRACT NO. 63770			ILLINOIS FED. AID PROJECT CMM 9003(757)

SCALE
5'
10'

PLAN	SURVEYED	PLOTTED	CHECKED
NOTE BOOK NO.	BY	DATE	DATE

PROFILE	SURVEYED	PLOTTED	CHECKED
NOTE BOOK NO.	BY	DATE	DATE

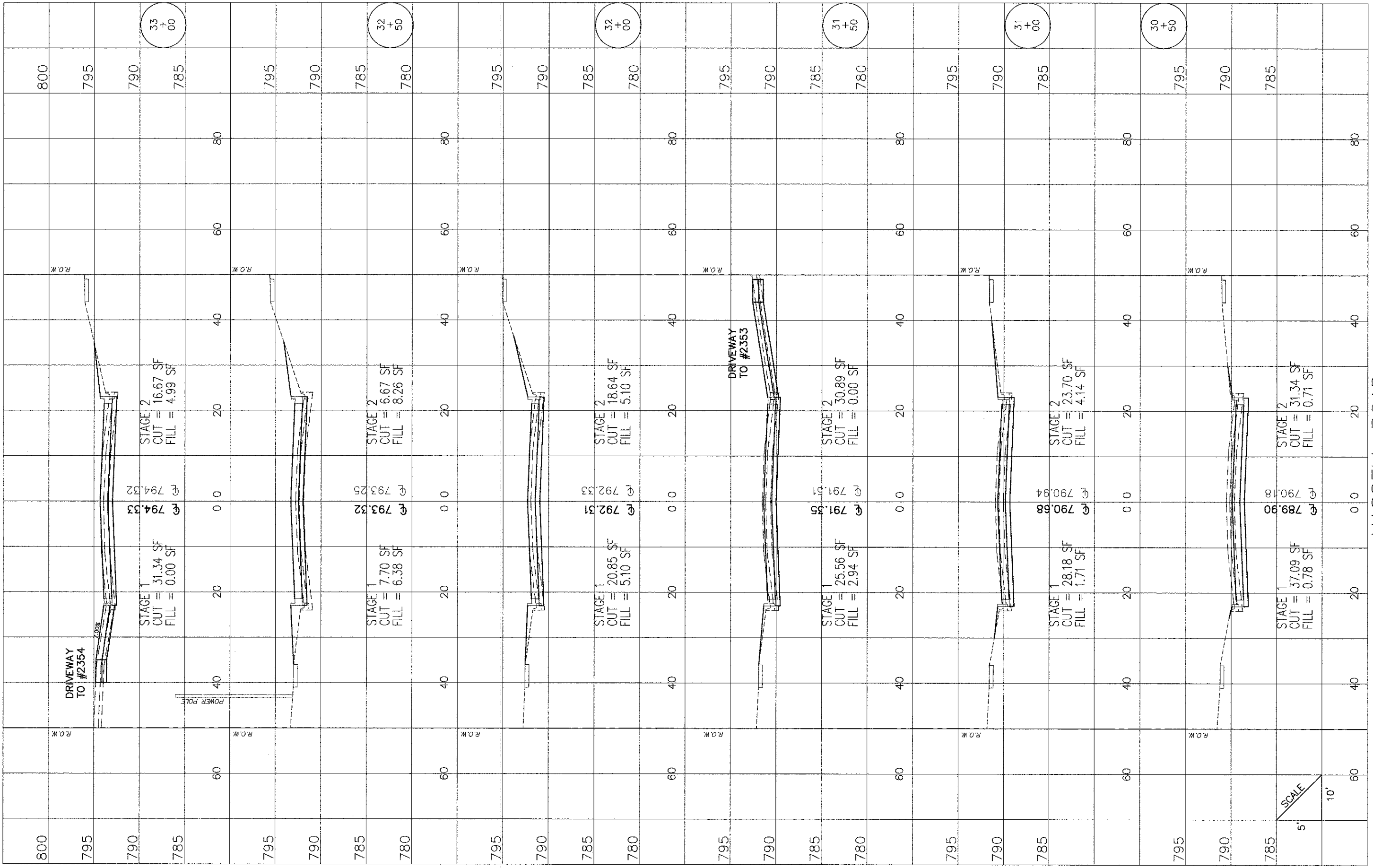

FILE NAME =
Hassell Plan-Profile.dwg

DESIGNED -	REVISED -
DRAWN -	REVISED -
CHECKED -	REVISED -
DATE -	REVISED -

STATE OF ILLINOIS
DEPARTMENT OF TRANSPORTATION

Hassell Road STP Project
Cross Sections

SHEET NO. 8 OF 27 SHEETS STA. 30+50 TO STA 33+00

F.A.U. RTE.	SECTION	COUNTY	TOTAL SHEETS	SHEET NO.
1100	11-00087-00-FP	Cook	164	145
CONTRACT NO. 63770				
ILLINOIS FED. AID PROJECT CMM 9003(757)				

SCALE
5'
10'

HASSELL ROAD

PLAN	SURVEYED	DATE	BY
NOTE BOOK	GRADES CHECKED		
NO. OF WAY CHECKED	STRUCTURE NOTATIONS		
DOUBLE NAME			

PROFILE	SURVEYED	DATE	BY
NOTE BOOK	GRADES CHECKED		
NO. OF WAY CHECKED	STRUCTURE NOTATIONS		

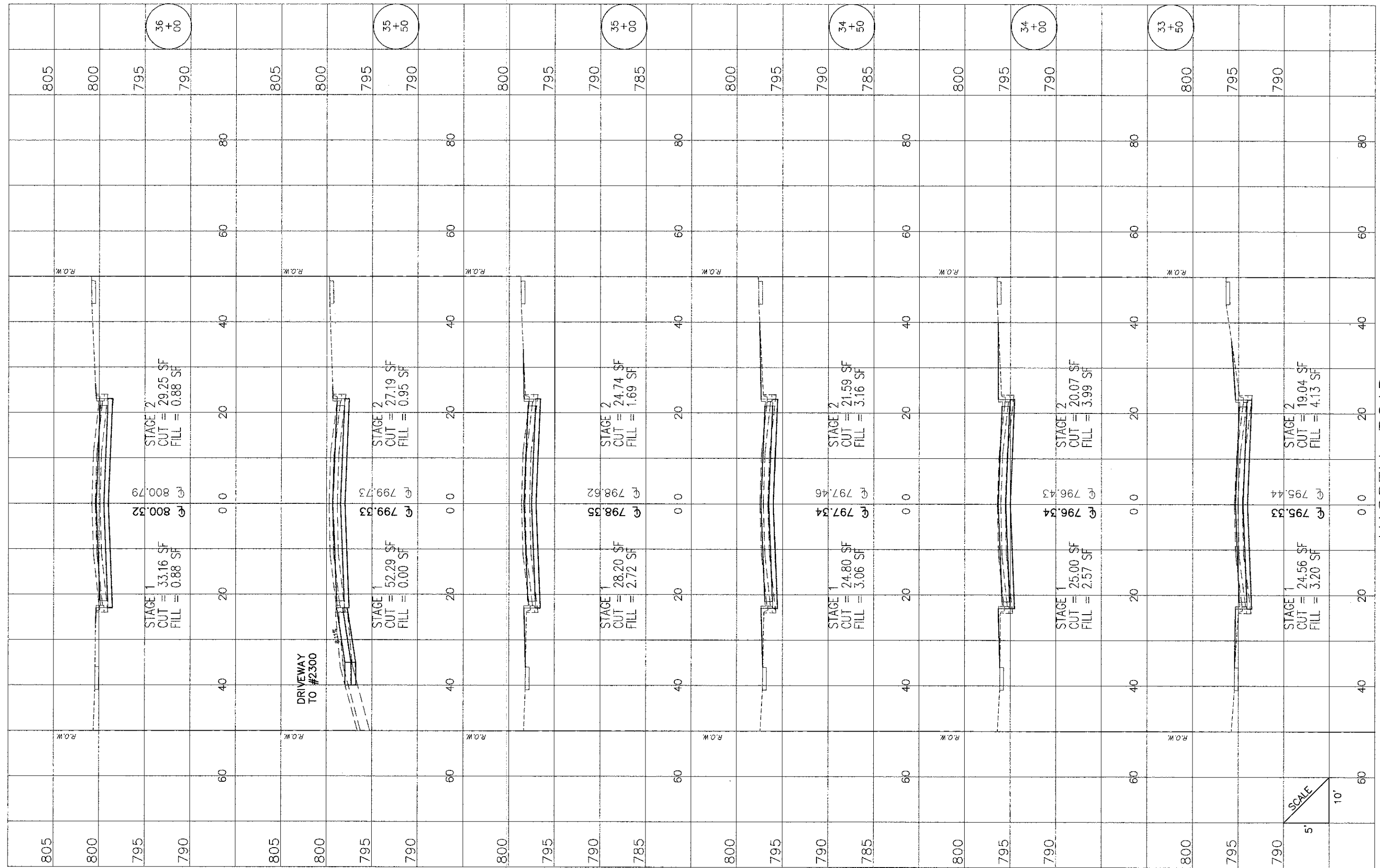

HASSELL ROAD

FILE NAME - Hassell Plan-Profile.dwg

DESIGNED -	REVISED -
DRAWN -	REVISED -
CHECKED -	REVISED -
DATE -	REVISED -

STATE OF ILLINOIS
DEPARTMENT OF TRANSPORTATION

Hassell Road STP Project
Cross Sections

SHEET NO. 9 OF 27 SHEETS STA. 33+50 TO STA 36+00

F.A.U. RTE.	SECTION	COUNTY	TOTAL SHEETS	SHEET NO.
1100	11-00087-00-FP	Cook	164	146
CONTRACT NO. 63770			ILLINOIS FED. AID PROJECT CMM 8003(757)	

SCALE
5' 10'

PLAN	SURVEYED	DATE
	PLOTTED	BY
	ALIGNED	CHECKED
	NOTED	DATE
	NO. 1	NO. 2

PROFILE	SURVEYED	DATE
	PLOTTED	BY
	GRADES	CHECKED
	STRUCTURE	NOTATIONS
	NO. 1	NO. 2

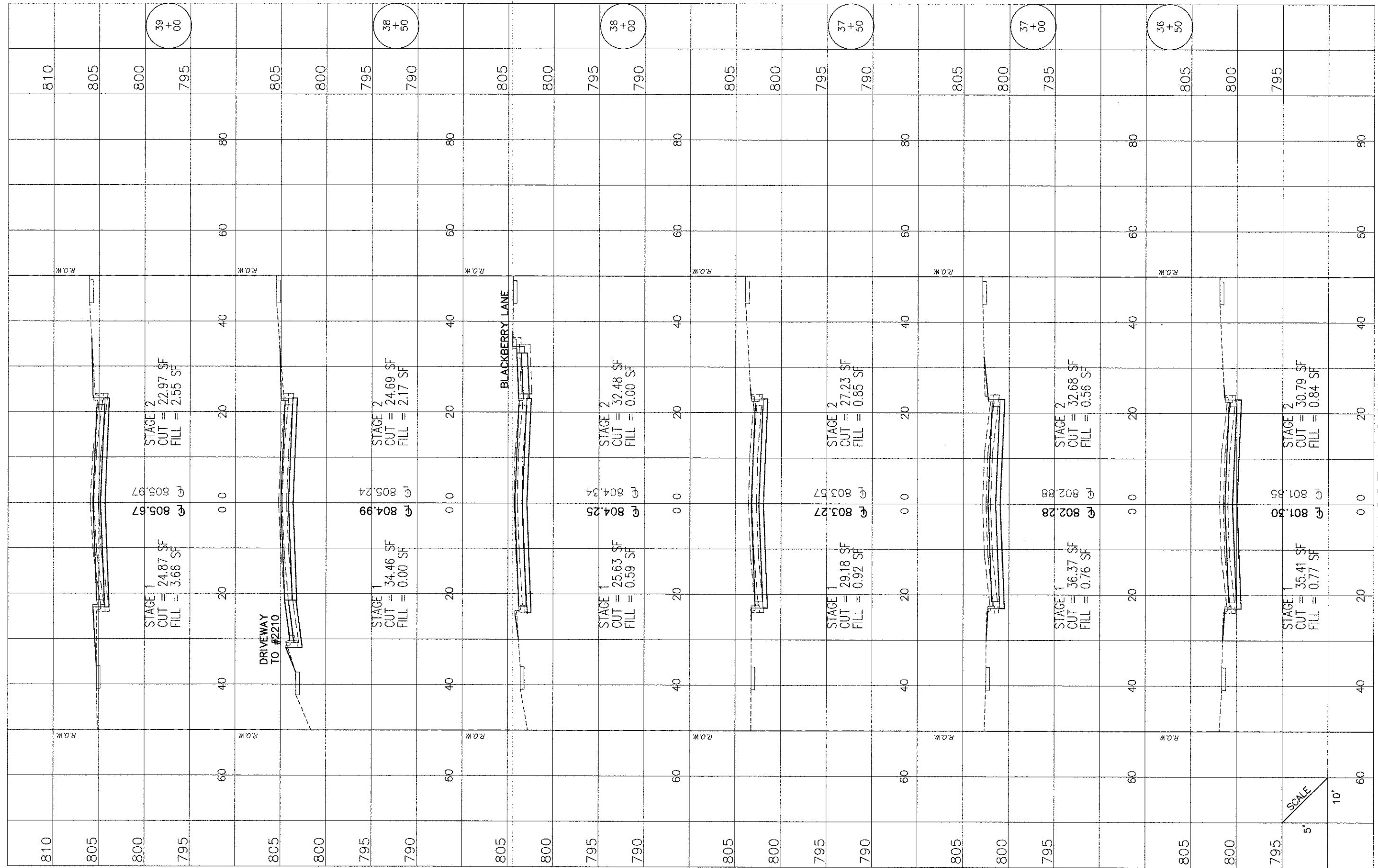

FILE NAME: Hassell Plan-Profile.dwg

DESIGNED -	REVISD -
DRAWN -	REVISD -
CHECKED -	REVISD -
DATE -	REVISD -

**STATE OF ILLINOIS
DEPARTMENT OF TRANSPORTATION**

Hassell Road STP Project
Cross Sections

SHEET NO. 10 OF 27 SHEETS STA. 36+50 TO STA 39+00

F.A.U. RTE.	SECTION	COUNTY	TOTAL SHEETS	SHEET NO.
1100	11-00087-00-FP	Cook	164	147
CONTRACT NO. 63770			ILLINOIS FED. AID PROJECT CMM 9003(757)	

SCALE
5'
10'

HASSELL ROAD

PLAN	SURVEYED	DATE	BY
NOTE BOOK NO.	PLOTTED		
	ALIGNMENT CHECKED		
	PROFILE NAME		

PROFILE	SURVEYED	DATE	BY
NOTE BOOK NO.	PLOTTED		
	GRADES CHECKED		
	STRUCTURE NOTATIONS OK'D		

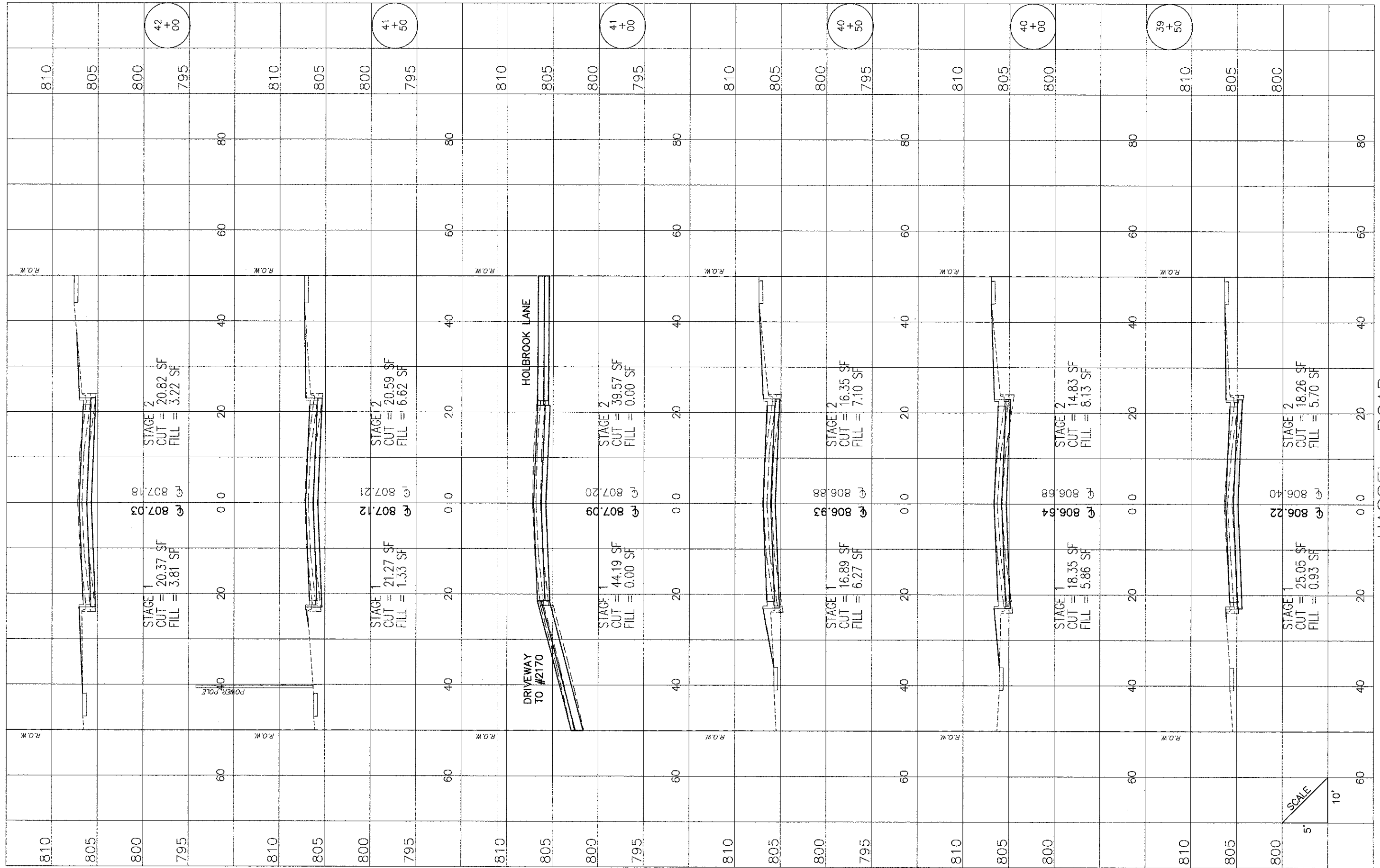

FILE NAME = Hassell Plan-Profile.dwg

DESIGNED -	REVISED -
DRAWN -	REVISED -
CHECKED -	REVISED -
DATE -	REVISED -

**STATE OF ILLINOIS
DEPARTMENT OF TRANSPORTATION**

Hassell Road STP Project
Cross Sections

SHEET NO. 11 OF 27 SHEETS STA. 39+50 TO STA 42+00

F.A.U. RTE. 1100	SECTION 11-00087-00-FP	COUNTY Cook	TOTAL SHEETS 164	SHEET NO. 148
CONTRACT NO. 63770			ILLINOIS FED. AID PROJECT CMM 9003(757)	

PLAN	SURVEYED	DATE	BY
NOTE BOOK NO.	ALIGNED		
	CHECKED		
	DATE		

PROFILE	SURVEYED	DATE	BY
NOTE BOOK NO.	GRADES CHECKED		
	STRUCTURE NOTATIONS OK'D		
	DATE		

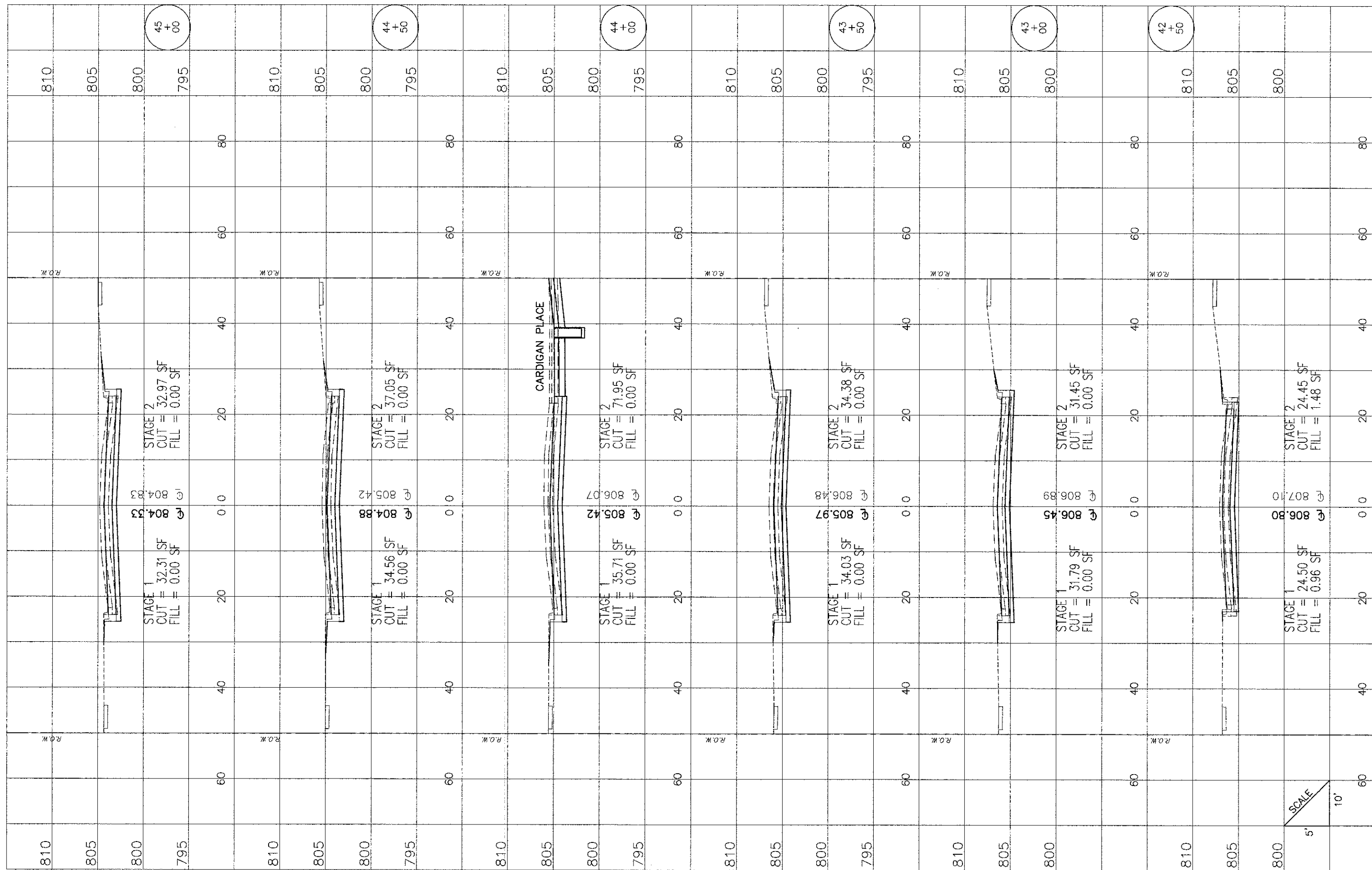

FILE NAME - Hassell Plan--Profile.dwg

DESIGNED -	REVISED -
DRAWN -	REVISED -
CHECKED -	REVISED -
DATE -	REVISED -

**STATE OF ILLINOIS
DEPARTMENT OF TRANSPORTATION**

Hassell Road STP Project
Cross Sections

SHEET NO. 12 OF 27 SHEETS STA. 42+50 TO STA 45+00

F.A.U. RTE.	SECTION	COUNTY	TOTAL SHEETS	SHEET NO.
1100	11-00087-00-FP	Cook	164	149
CONTRACT NO. 63770			ILLINOIS FED. AID PROJECT CMM 9003(757)	

PROFILE	DATE	BY
SURVEYED		
NOTED		
CHECKED		
BY		
NO.		

PLAN	DATE	BY
SURVEYED		
NOTED		
CHECKED		
BY		
NO.		

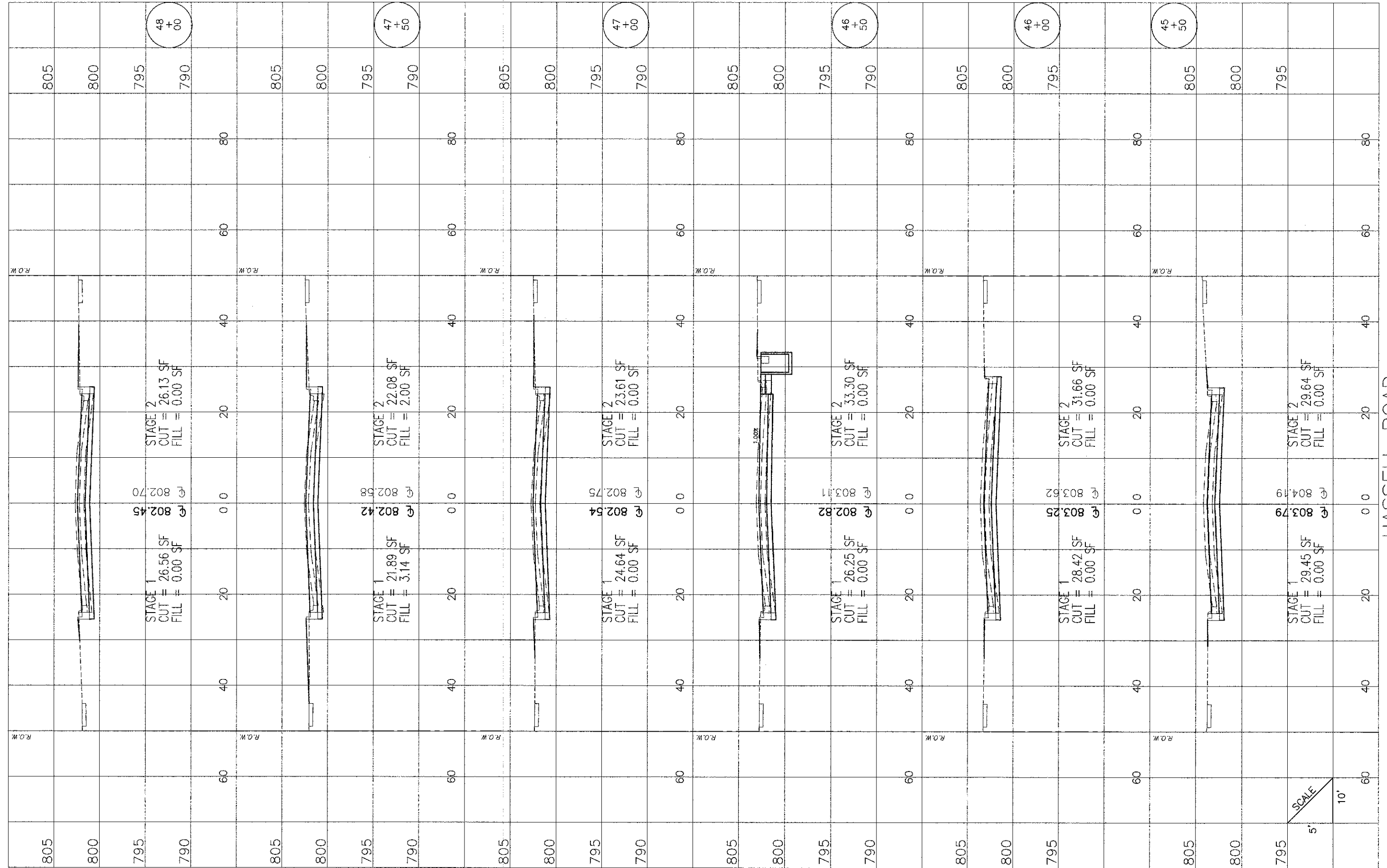

FILE NAME -	DESIGNED -	REVISED -
Hassell Plan-Profile.dwg	DRAWN -	REVISED -
	CHECKED -	REVISED -
	DATE -	REVISED -

STATE OF ILLINOIS
DEPARTMENT OF TRANSPORTATION

Hassell Road STP Project
Cross Sections

SHEET NO. 13 OF 27 SHEETS STA. 45+50 TO STA. 48+00

F.A.U. RTE.	SECTION	COUNTY	TOTAL SHEETS	SHEET NO.
1100	11-00087-00-FP	Cook	164	150
CONTRACT NO. 63770			ILLINOIS FED. AID PROJECT CMM 9003(757)	

HASSELL ROAD

SCALE
5' 10'

PLAN	SURVEYED	DATE	BY
NOTE BOOK	GRADES CHECKED		
NO.	STRUCTURE NOTATIONS CHD		
	ALIGNMENT CHECKED		
	ST. OF WAY CHECKED		
	DOUBLE NAME		

PROFILE	SURVEYED	DATE	BY
NOTE BOOK	GRADES CHECKED		
NO.	STRUCTURE NOTATIONS CHD		
	ALIGNMENT CHECKED		
	ST. OF WAY CHECKED		

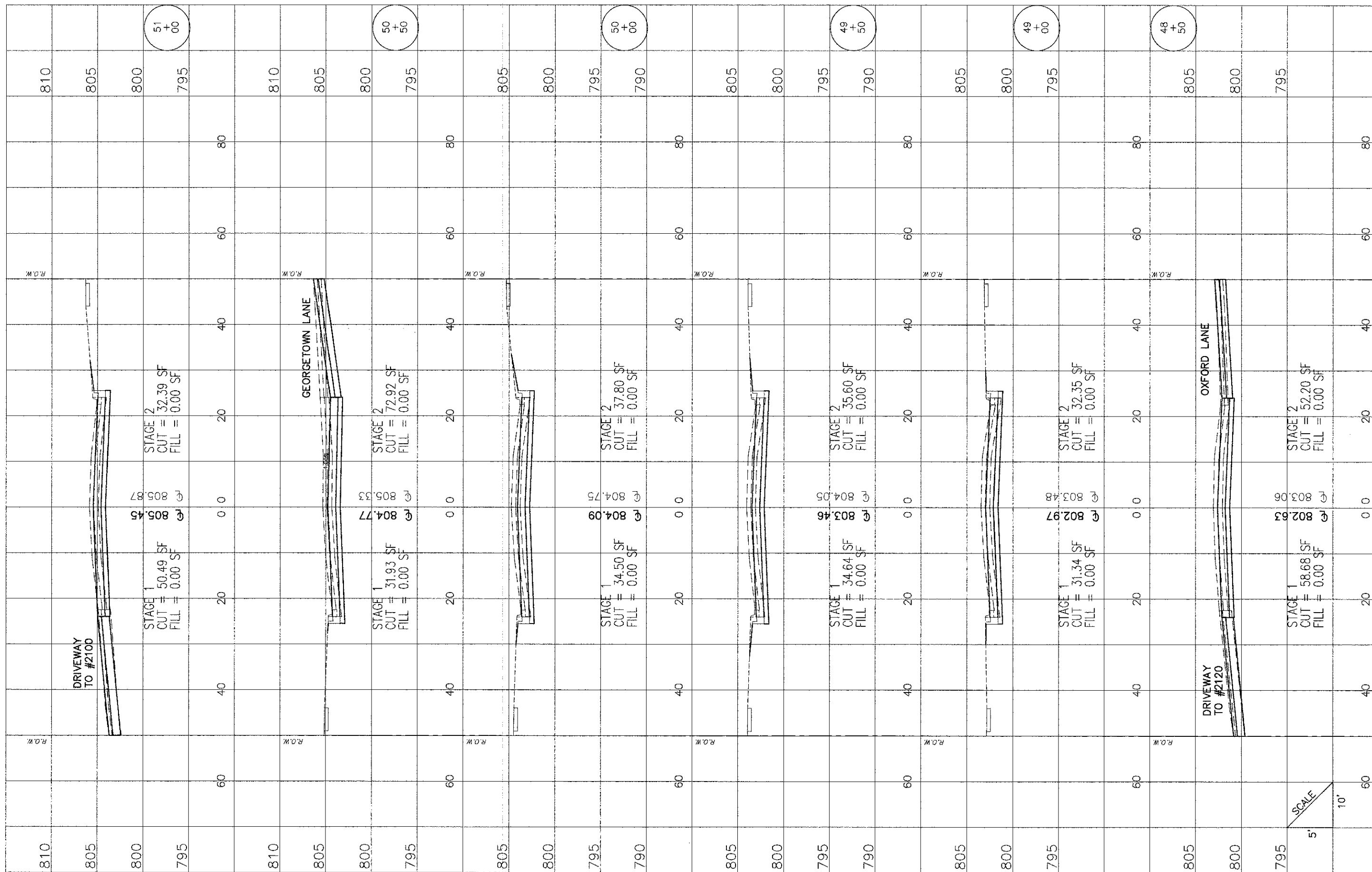

HASSELL ROAD

PROFILE SURVEYED	DATE	BY	DATE
PLOTTED			
NOTE BOOK NO.			
STRUCTURE NOTATION			

PLAN SURVEYED	DATE	BY	DATE
PLOTTED			
NOTE BOOK NO.			
STRUCTURE NOTATION			

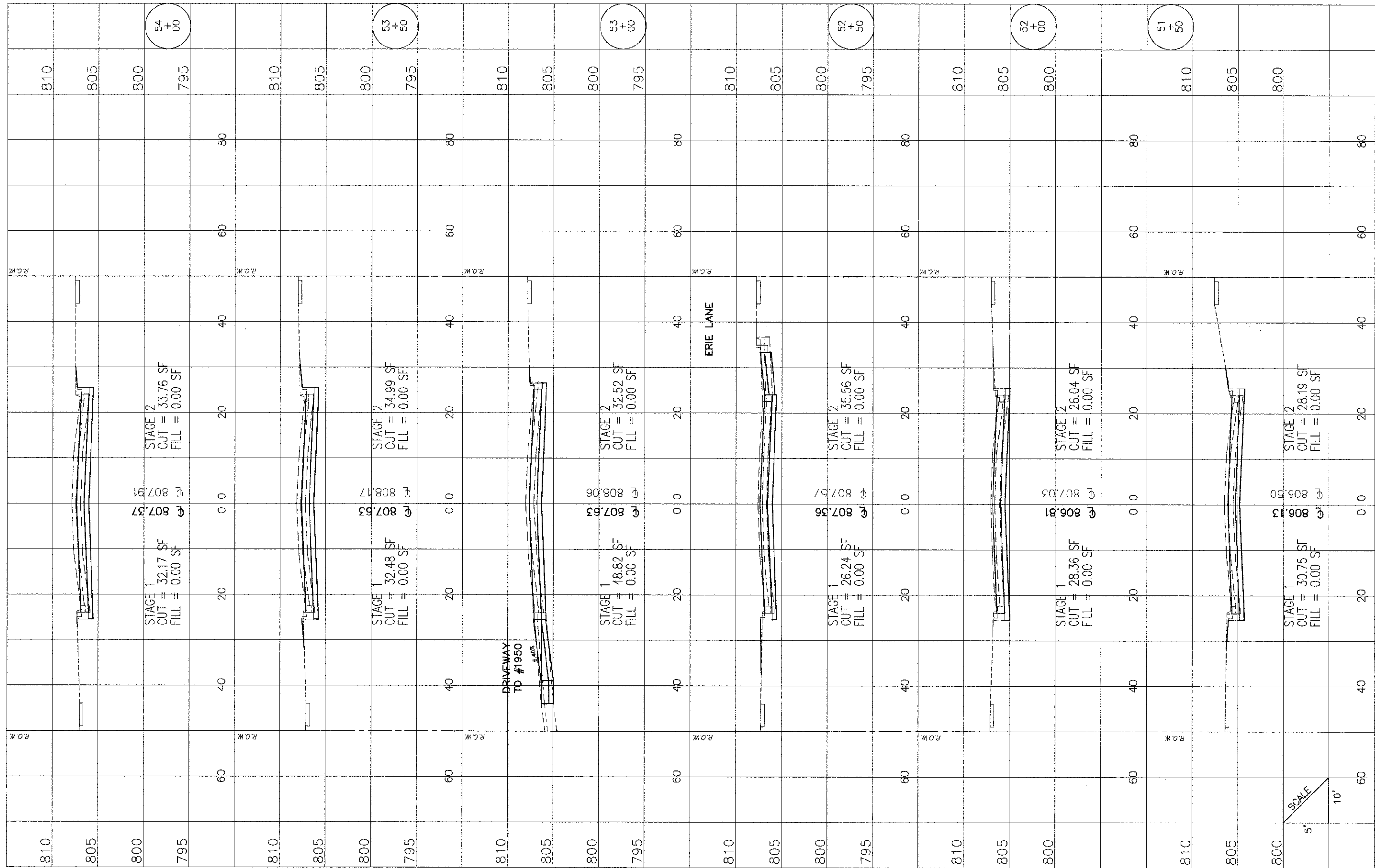

HASSELL ROAD

PLAN	DESIGNED	DATE	BY
NOTE BOOK NO.	NOTED		
	ALIGNED		
	CHECKED		
	DATE		

PROFILE	DESIGNED	DATE	BY
NOTE BOOK NO.	NOTED		
	STRUCTURE		
	CHECKED		
	DATE		

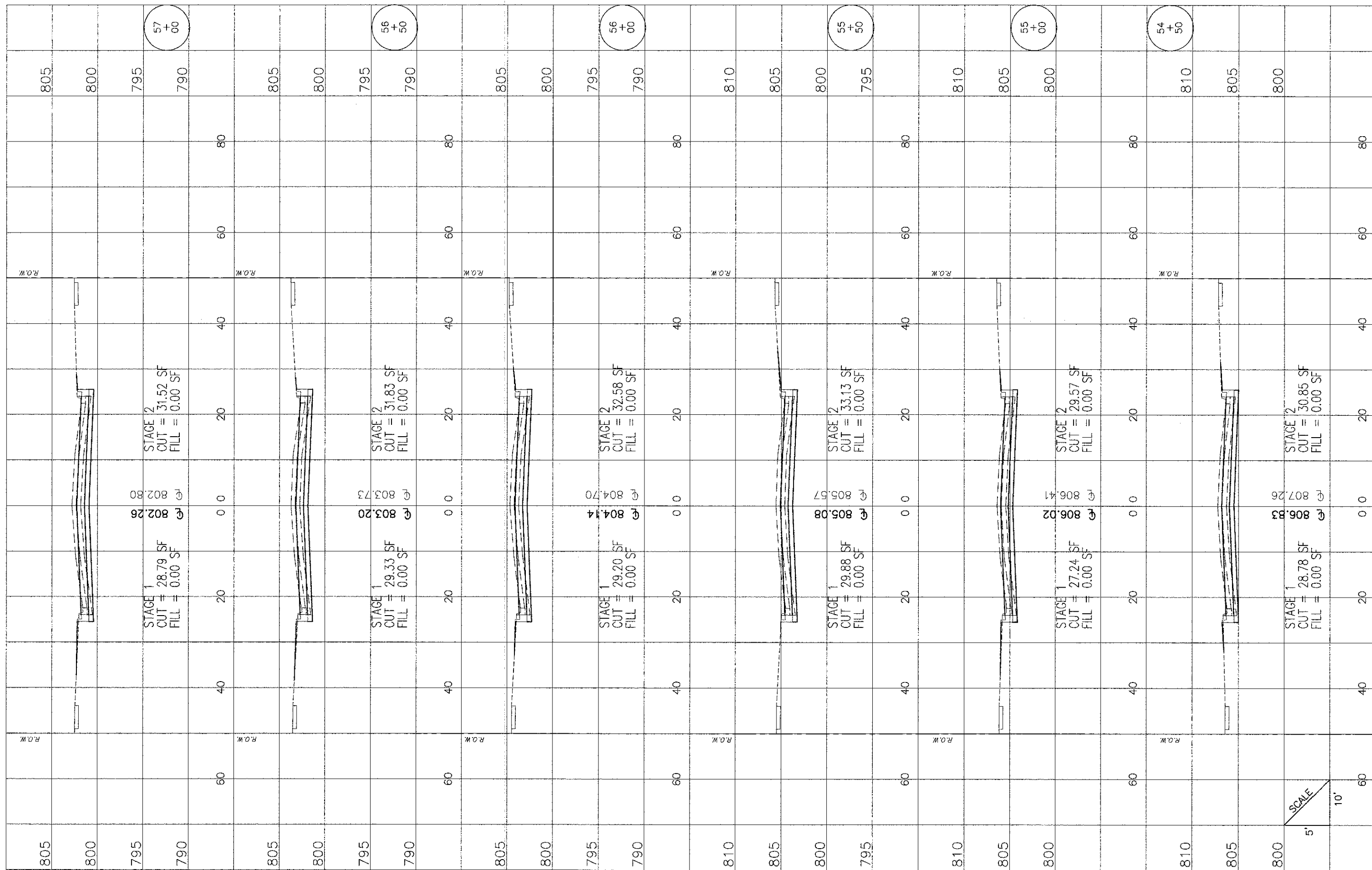

HASSELL ROAD

PLAN	REVISED	DATE
NOTE BOOK	ALIGNED	BY
NO.	NO.	NO.
	CHECKED	DATE
	DATE	BY
	NO.	NO.

PROFILE	REVISED	DATE
NOTE BOOK	GRADES CHECKED	BY
NO.	NO.	NO.
	NO.	NO.

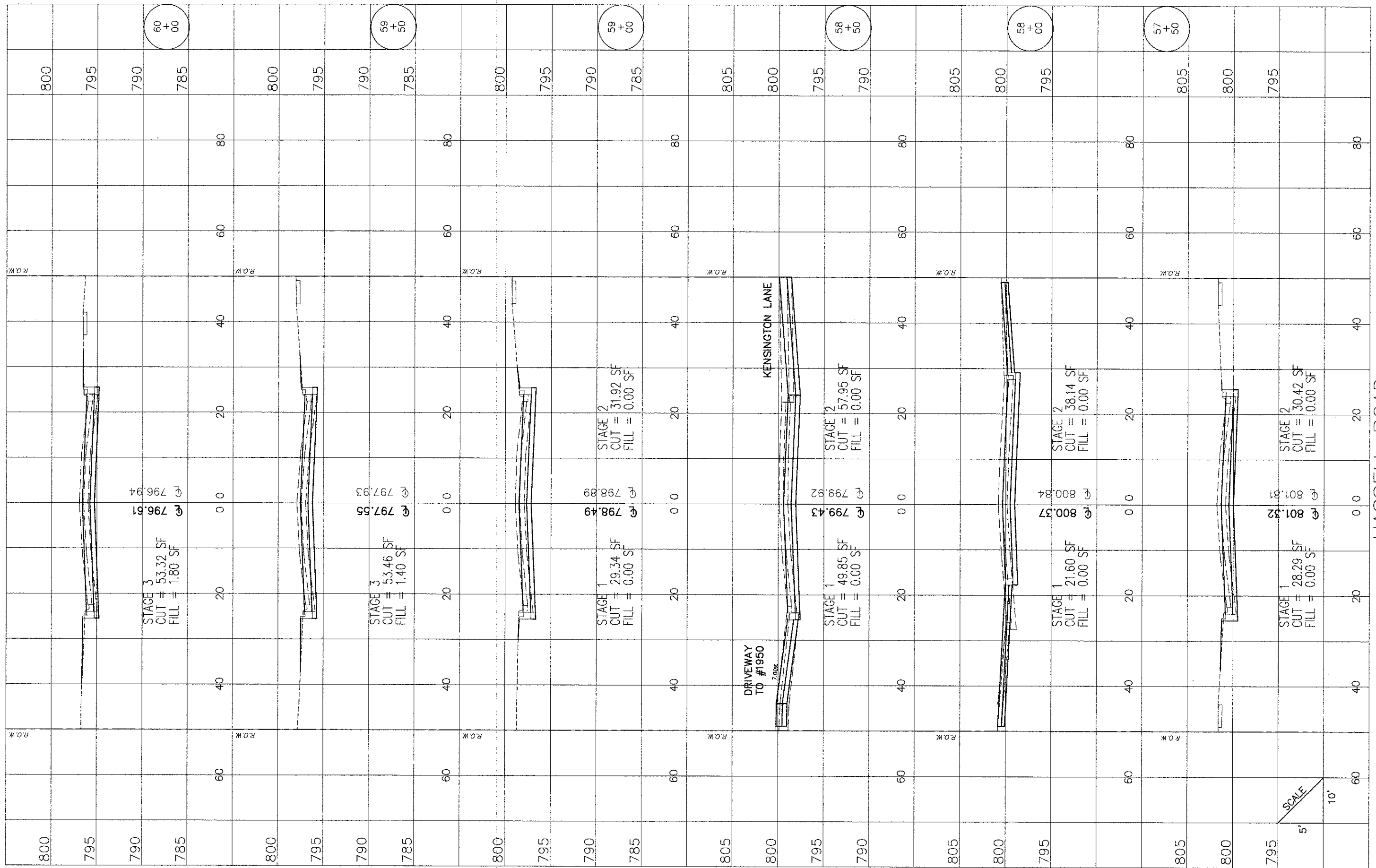

FILE NAME - Hassell Plan-Profile.dwg

DESIGNED -	REVISED -
DRAWN -	REVISED -
CHECKED -	REVISED -
DATE -	REVISED -

STATE OF ILLINOIS
DEPARTMENT OF TRANSPORTATION

Hassell Road STP Project
Cross Sections

SHEET NO. 17 OF 27 SHEETS STA. 57+50 TO STA 60+00

F.A.U. RITE	SECTION	COUNTY	TOTAL SHEETS	SHEET NO.
1100	11-00087-00-FP	Cook	164	154
CONTRACT NO. 63770			ILLINOIS FED. AID PROJECT CMM 9003(757)	

PLAN	SURVEYED
NOTE BOOK	ALIGNED
NO.	NO.
DATE	DATE
BY	BY

PROFILE	SURVEYED
NOTE BOOK	GRADES CHECKED
NO.	NO.
DATE	DATE
BY	BY

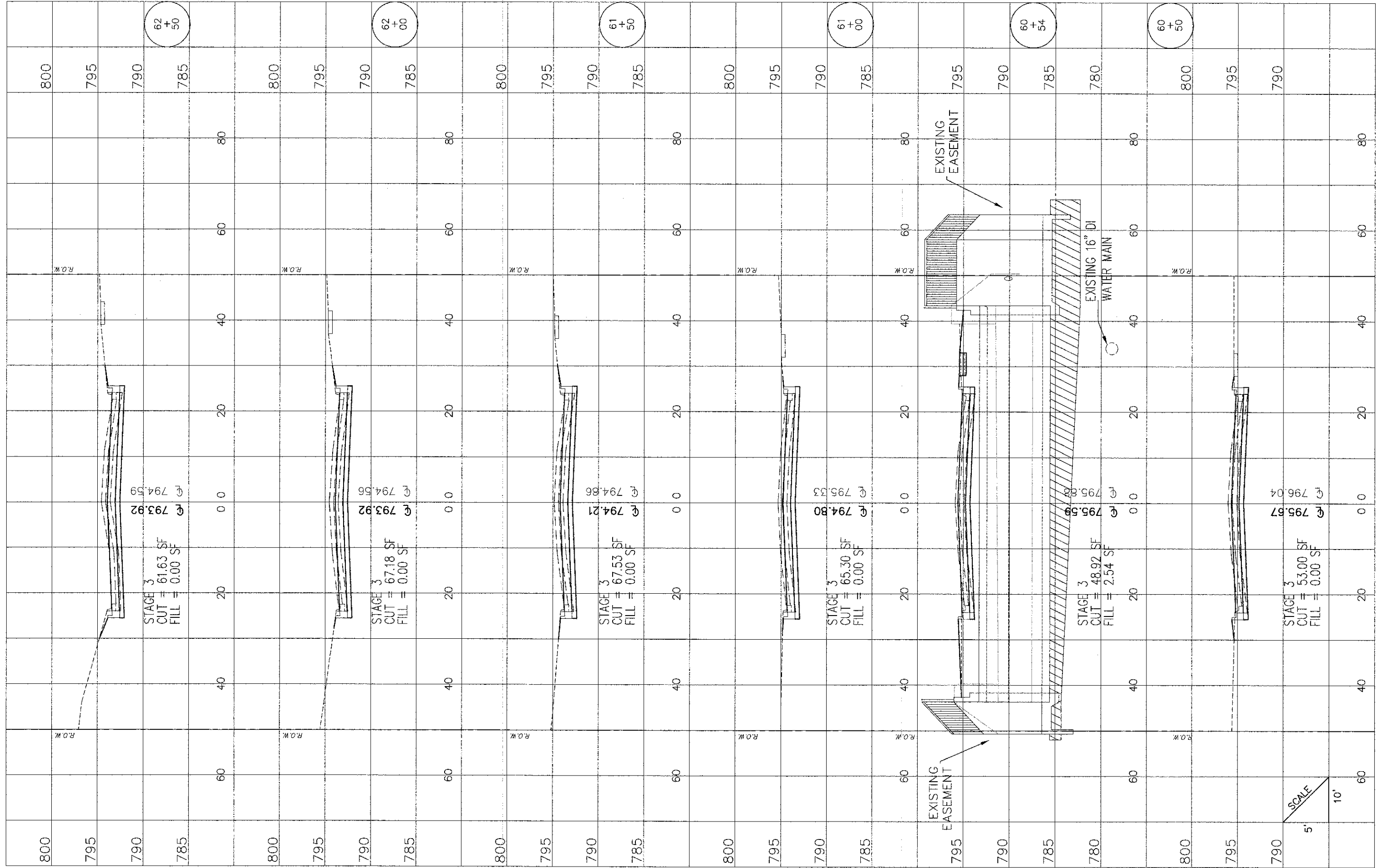

FILE NAME --
Hassell Plan-Profile.dwg

DESIGNED --	REVISED --
DRAWN --	REVISED --
CHECKED --	REVISED --
DATE --	REVISED --

**STATE OF ILLINOIS
DEPARTMENT OF TRANSPORTATION**

**Hassell Road STP Project
Cross Sections**

SHEET NO. 18 OF 27 SHEETS STA. 60+50 TO STA 62+50

F.A.U. RTE.	SECTION	COUNTY	TOTAL SHEETS	SHEET NO.
1100	11-00087-00-FP	Cook	164	155
CONTRACT NO. 63770			ILLINOIS FED. AID PROJECT CMM 9003(757)	

SCALE
5' 10'

HASSELL ROAD

PLAN	SURVEYED	DATE	BY
NOTE BOOK NO.	FLOTTED		
	ALIGNMENT CHECKED		
	NO. _____		
	DATE _____		
	BY _____		
	NO. _____		
	DATE _____		
	BY _____		
	NO. _____		
	DATE _____		
	BY _____		

PROFILE	SURVEYED	DATE	BY
NOTE BOOK NO.	FLOTTED		
	GRADES CHECKED		
	STRUCTURE NOTATIONS OK'D		
	NO. _____		
	DATE _____		
	BY _____		
	NO. _____		
	DATE _____		
	BY _____		

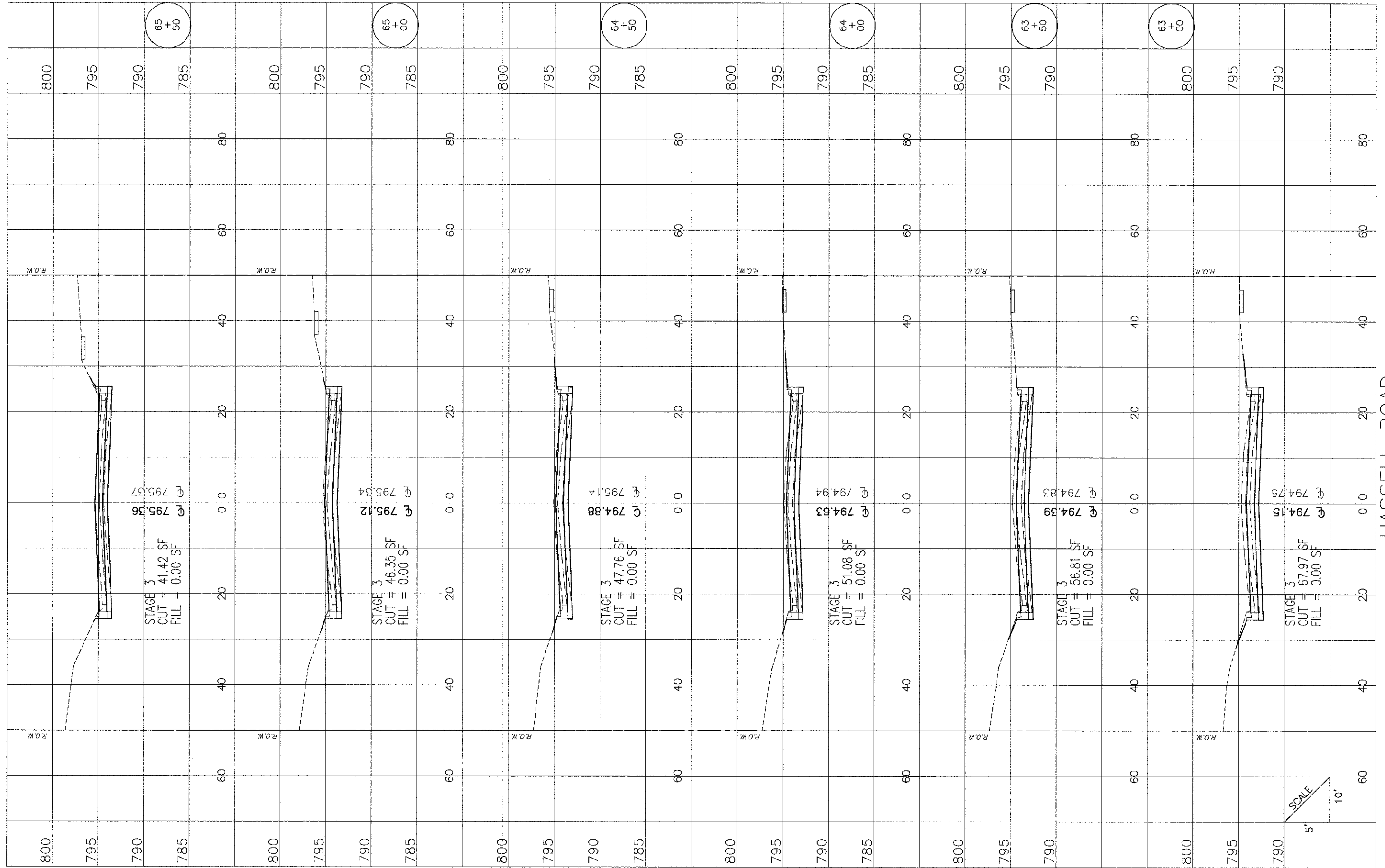

HASSELL ROAD

SCALE
5'
10'

FILE NAME =
Hassell Plan-Profile.dwg

DESIGNED -	REVISED -
DRAWN -	REVISED -
CHECKED -	REVISED -
DATE -	REVISED -

STATE OF ILLINOIS
DEPARTMENT OF TRANSPORTATION

Hassell Road STP Project
Cross Sections
SHEET NO. 19 OF 27 SHEETS STA. 63+00 TO STA 65+50

F.A.U. RTE.	SECTION	COUNTY	TOTAL SHEETS	SHEET NO.
1100	11-00087-00-FP	Cook	164	156
CONTRACT NO. 63770			ILLINOIS FED. AID PROJECT CMM 9003(757)	

PROFILE	DESIGNED	DATE	BY
NOTED	NOTED		
NOTE BOOK	GRADES CHECKED		
NO.	NO.		
	NO. OF STAKES		
	NO. OF POINTS		
	NO. OF STATIONS		

PLAN	DESIGNED	DATE
NOTED	NOTED	
NOTE BOOK	ALIGNMENT CHECKED	
NO.	NO.	
	NO. OF STAKES	
	NO. OF POINTS	
	NO. OF STATIONS	

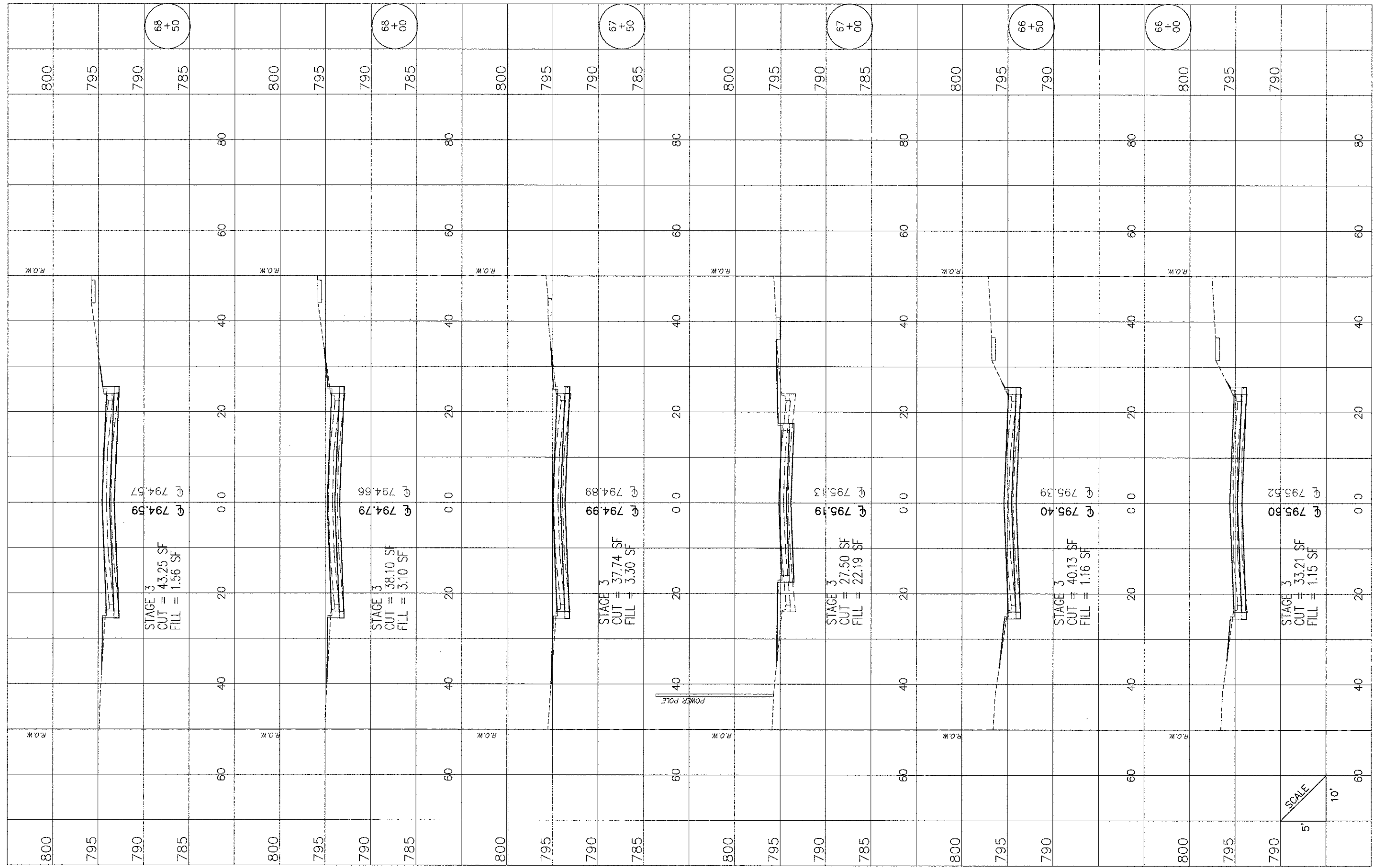

HASSELL ROAD

FILE NAME -
Hassell Plan-Profile.dwg

DESIGNED -	REVISED -
DRAWN -	REVISED -
CHECKED -	REVISED -
DATE -	REVISED -

STATE OF ILLINOIS
DEPARTMENT OF TRANSPORTATION

Hassell Road STP Project
Cross Sections

SHEET NO. 20 OF 27 SHEETS STA. 66+00 TO STA 68+50

F.A.U. R.I.E.	SECTION	COUNTY	TOTAL SHEETS	SHEET NO.
1100	11-00087-00-FP	Cook	164	157
CONTRACT NO. 63770			ILLINOIS FED. AID PROJECT CMM 9003(757)	

PLAN	SURVEYED	DATE
NOTE BOOK NO.	GRADES CHECKED	BY
	ALIGNED	
	CHECKED	
	BY	
	DATE	
	PROJECT NAME	

PROFILE	SURVEYED	DATE
NOTE BOOK NO.	GRADES CHECKED	BY
	ALIGNED	
	CHECKED	
	BY	
	DATE	
	PROJECT NAME	

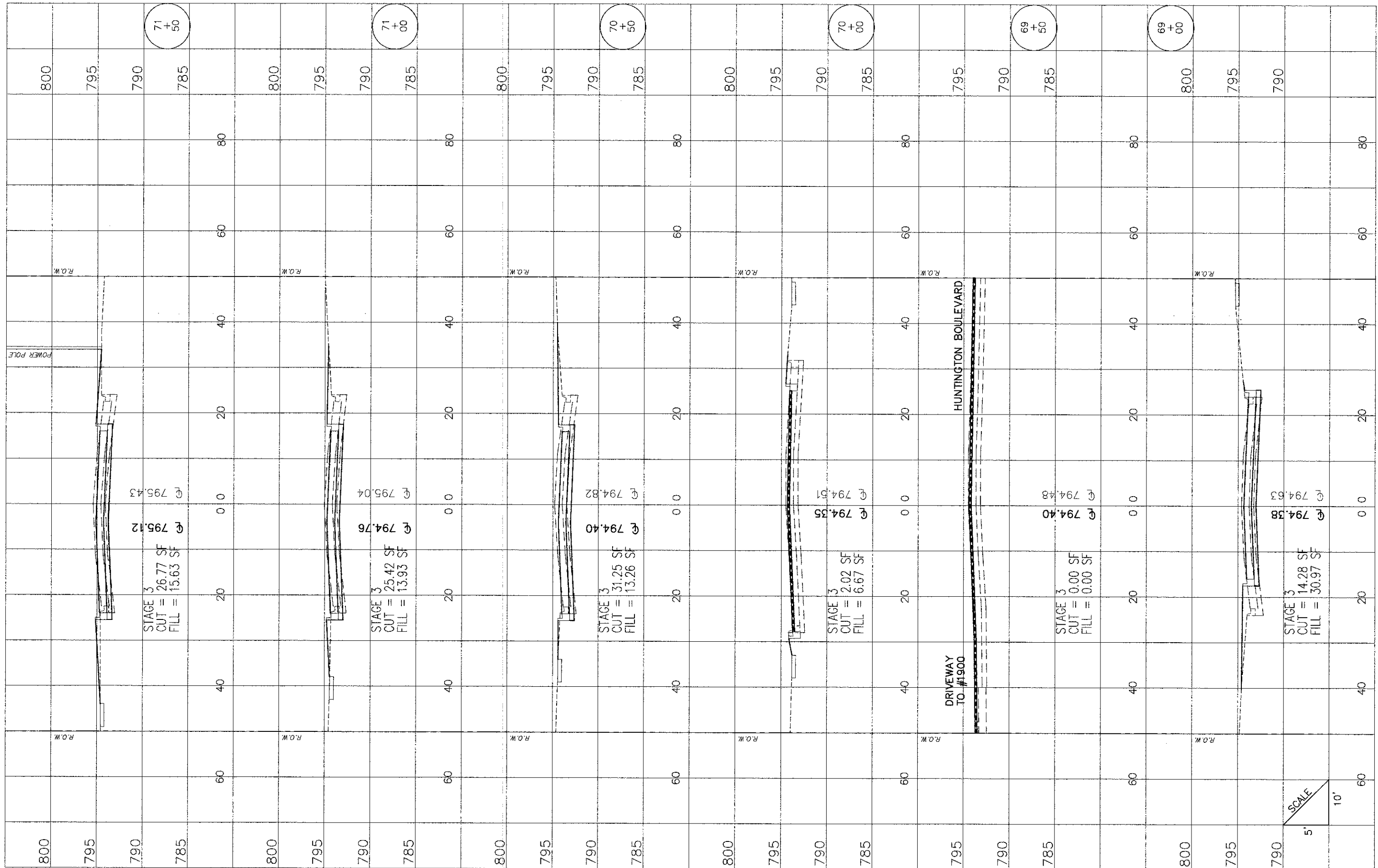

FILE NAME - Hassell Plan-Profile.dwg

DESIGNED -	REVISIONS -
DRAWN -	REVISIONS -
CHECKED -	REVISIONS -
DATE -	REVISIONS -

**STATE OF ILLINOIS
DEPARTMENT OF TRANSPORTATION**

Hassell Road STP Project
Cross Sections

SHEET NO. 21 OF 27 SHEETS STA. 69+00 TO STA 71+50

F.A.U. RTE.	SECTION	COUNTY	TOTAL SHEETS	SHEET NO.
1100	11-00087-00-FP	Cook	164	158
CONTRACT NO. 63770			ILLINOIS FED. AID PROJECT CMM 9003(757)	

PLAN
 DIVIDED
 NOTE BOOK
 NO.

PROFILE
 DATE
 BY
 NOTE BOOK
 NO.

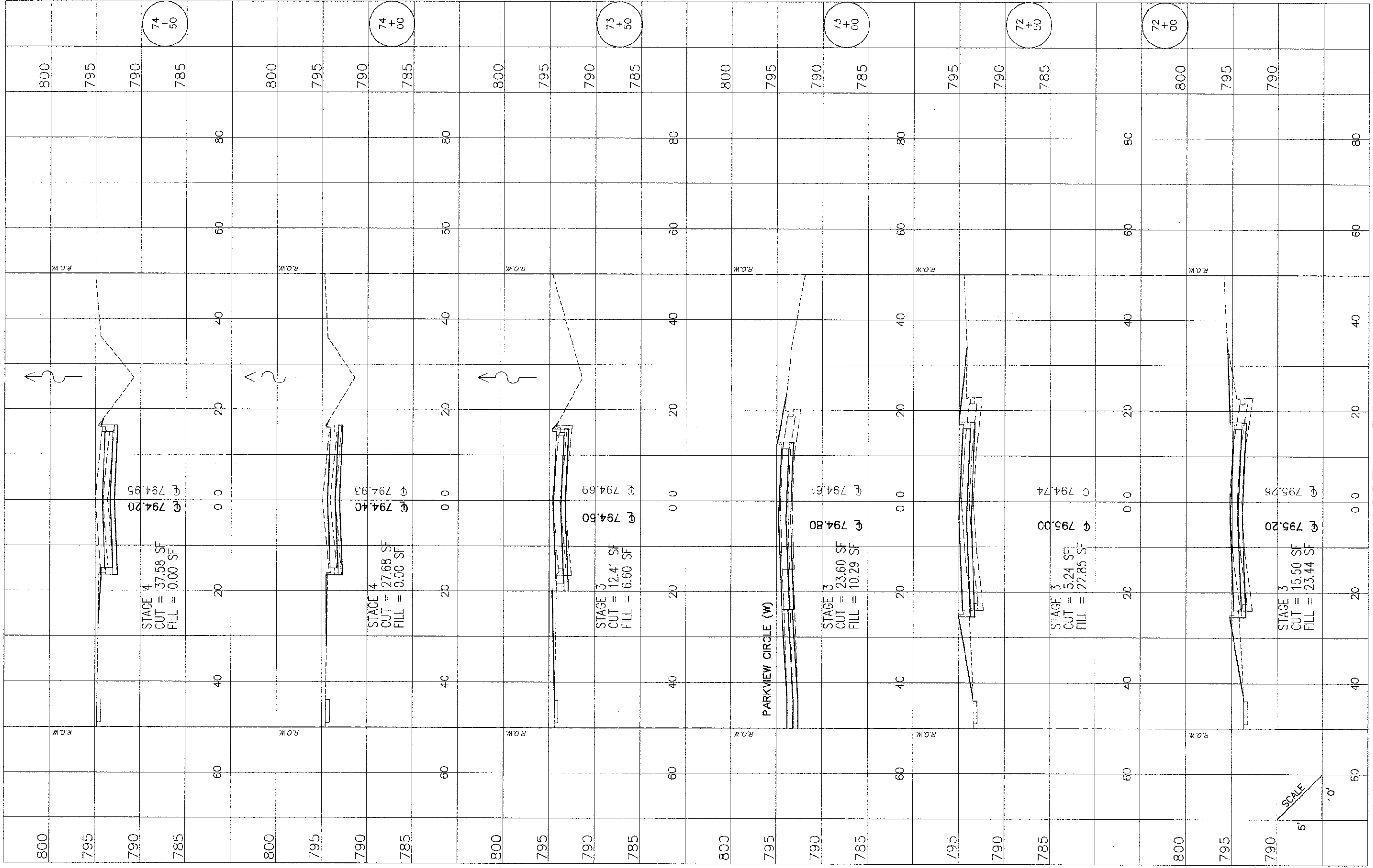

PARKVIEW CIRCLE (W)

HASSELL ROAD

SCALE
 5'
 10'

FILE NAME = Hassell Plan-Profile.dwg

DESIGNED -
 DRAWN -
 CHECKED -
 DATE -

STATE OF ILLINOIS
 DEPARTMENT OF TRANSPORTATION

Hassell Road STP Project
 Cross Sections

SHEET NO. 22 OF 27 SHEETS STA. 72+00 TO STA 74+50

F.A.U. RTE.	SECTION	COUNTY	TOTAL SHEETS	SHEET NO.
1100	11-00087-00-FP	Cook	164	159

CONTRACT NO. 63770 ILLINOIS FED. AID PROJECT CMM 9063(757)

PLAN	SURVEYED	DATE	BY
NOTE BOOK NO.	PLOTTED		
	ALIGNED		
	CHECKED		
	DATE		
	BY		

PROFILE	SURVEYED	DATE	BY
NOTE BOOK NO.	PLOTTED		
	GRADES CHECKED		
	STRUCTURE NOTATIONS CHKS		

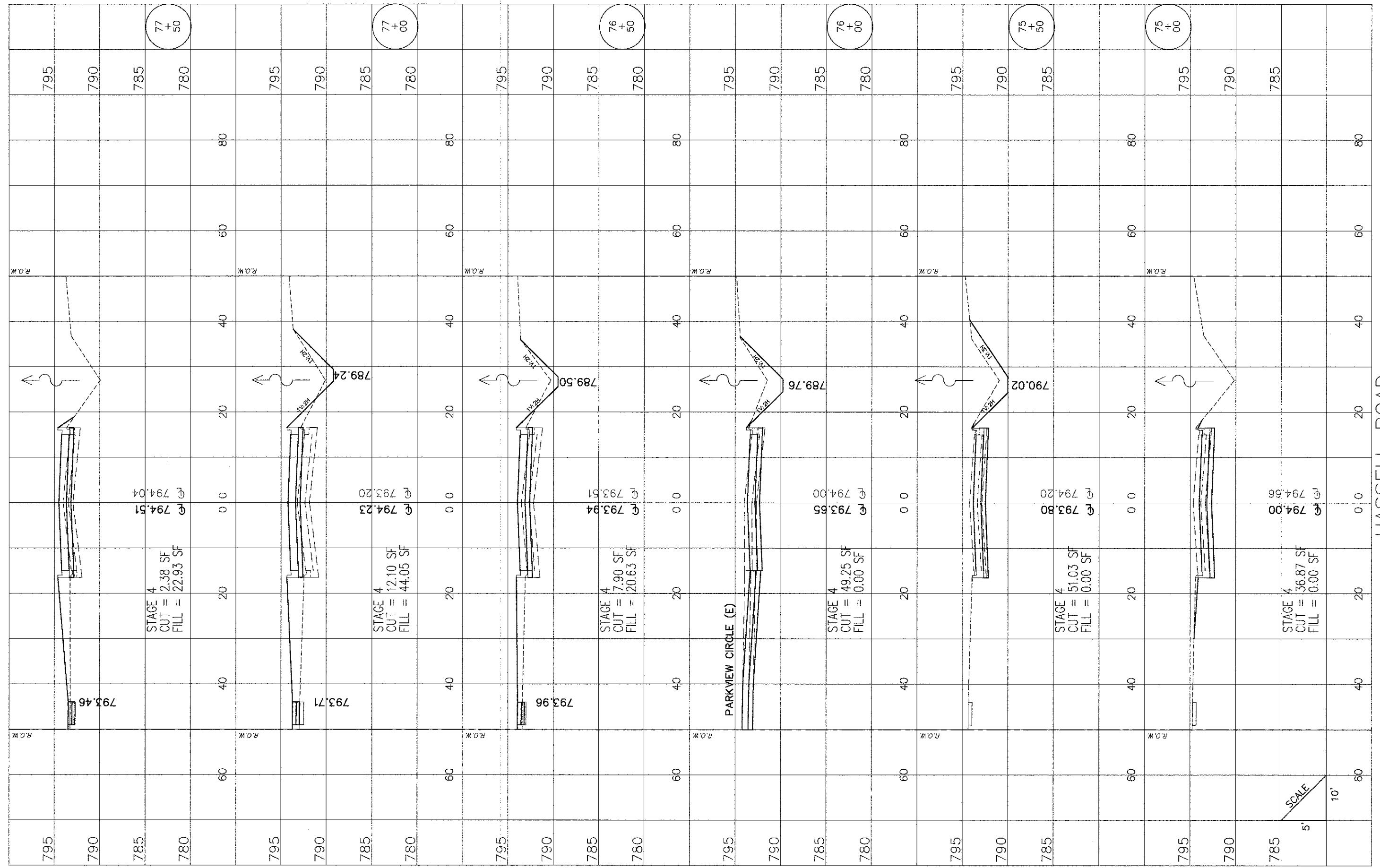

HASSELL ROAD

FILE NAME -
Hassell Plan-Profile.dwg

DESIGNED -	REVISED -
DRAWN -	REVISED -
CHECKED -	REVISED -
DATE -	REVISED -

STATE OF ILLINOIS
DEPARTMENT OF TRANSPORTATION

Hassell Road STP Project
Cross Sections
SHEET NO. 23 OF 27 SHEETS STA. 75+00 TO STA 77+50

F.A.U. RTE.	SECTION	COUNTY	TOTAL SHEETS	SHEET NO.
1100	11-00087-00-FP	Cook	164	160
CONTRACT NO. 63770			ILLINOIS FED. AID PROJECT CMM 9003(757)	

PLAN	SURVEYED	DATE	BY
NOTE BOOK NO.	PLOTTED	DATE	BY
	CHECKED	DATE	BY
	BY WAY CHECKED	DATE	BY
	DOUBLE NAME	DATE	BY

PROFILE	SURVEYED	DATE	BY
NOTE BOOK NO.	PLOTTED	DATE	BY
	CHECKED	DATE	BY
	BY WAY CHECKED	DATE	BY
	NOTARIS OFFICER	DATE	BY

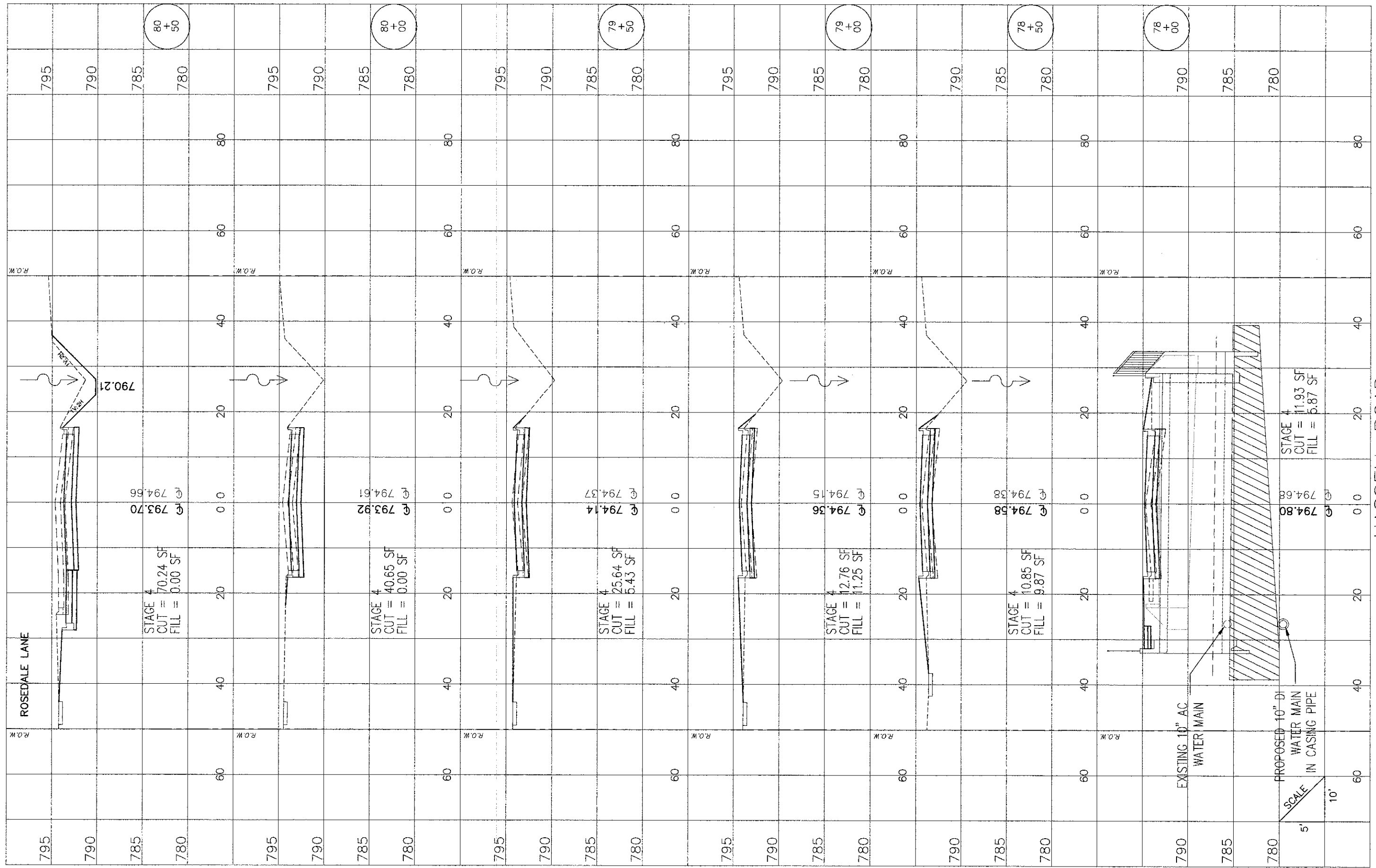

FILE NAME -
Hassell Plan-Profile.dwg

DESIGNED -	REVISD -
DRAWN -	REVISD -
CHECKED -	REVISD -
DATE -	REVISD -

**STATE OF ILLINOIS
DEPARTMENT OF TRANSPORTATION**

Hassell Road STP Project
Cross Sections

SHEET NO. 24 OF 27 SHEETS STA. 78+00 TO STA 80+50

F.A.U. RTE.	SECTION	COUNTY	TOTAL SHEETS	SHEET NO.
1100	11-00087-00-FP	Cook	164	161
CONTRACT NO. 63770			ILLINOIS FED. AID PROJECT CMM 9003(757)	

PLAN	DRAWN	DATE
NOTE BOOK NO.	ALIGNED CHECKED	
	PLotted	
	FILE NAME	

PROFILE	DATE	BY
NOTE BOOK NO.	DESIGNED	
	STRUCTURE NOTATIONS	

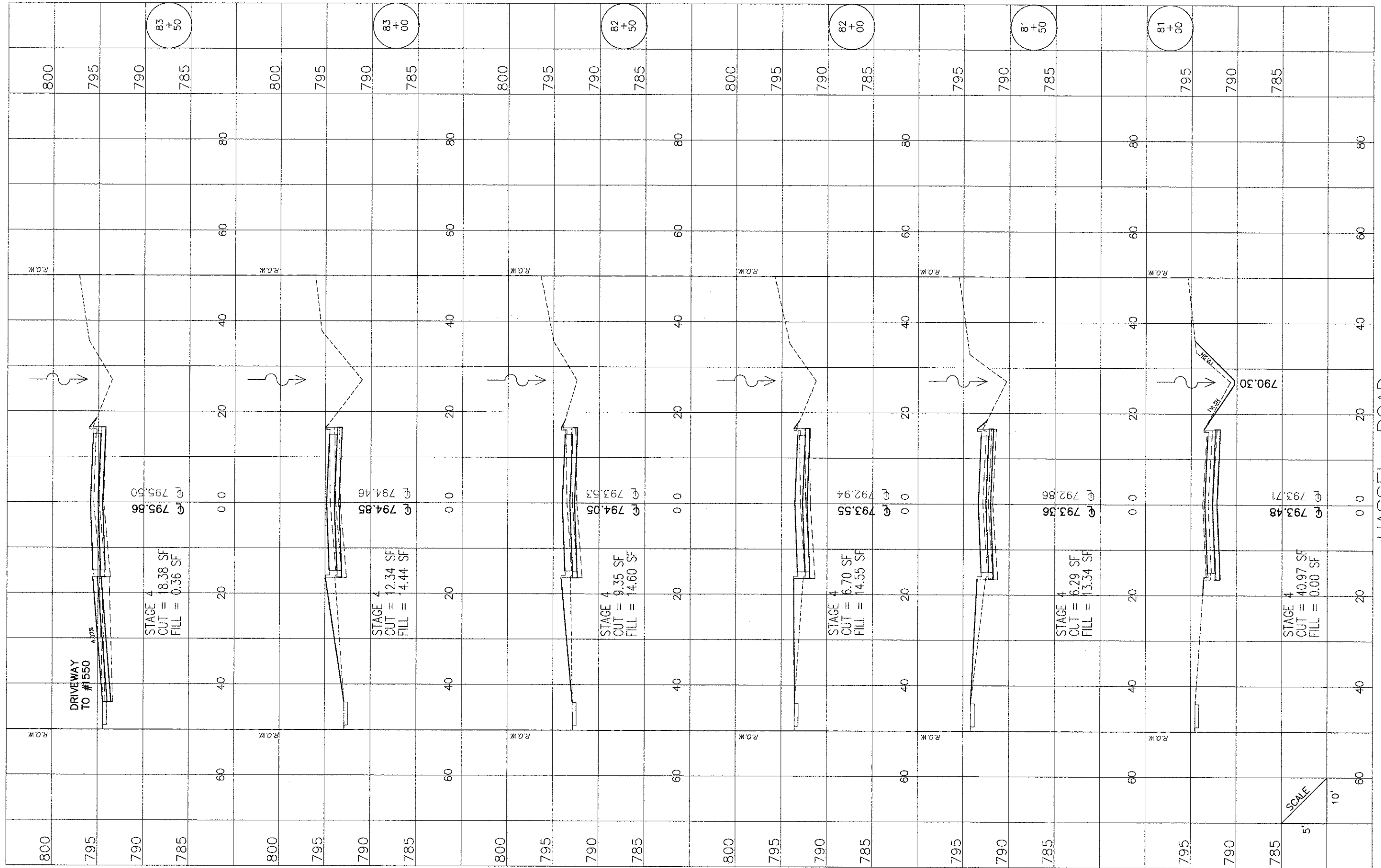

HASSELL ROAD

FILE NAME = Hassell Plan - Profile.dwg

DESIGNED -	REVISED -
DRAWN -	REVISED -
CHECKED -	REVISED -
DATE -	REVISED -

STATE OF ILLINOIS
DEPARTMENT OF TRANSPORTATION

Hassell Road STP Project
Cross Sections

SHEET NO. 25 OF 27 SHEETS STA. 81+00 TO STA 83+50

F.A.U. RTE	SECTION	COUNTY	TOTAL SHEETS	SHEET NO.
1100	11-00087-00-FP	Cook	164	162
CONTRACT NO. 63770			ILLINOIS FED. AID PROJECT CMM 9003(757)	

SCALE
5' 10'

PLAN	SURVEYED	DATE	BY
NOTE BOOK NO.	PLOTTED		
	DESIGNED		
	CHECKED		
	DATE		

PROFILE	SURVEYED	DATE	BY
NOTE BOOK NO.	PLOTTED		
	DESIGNED		
	CHECKED		
	DATE		

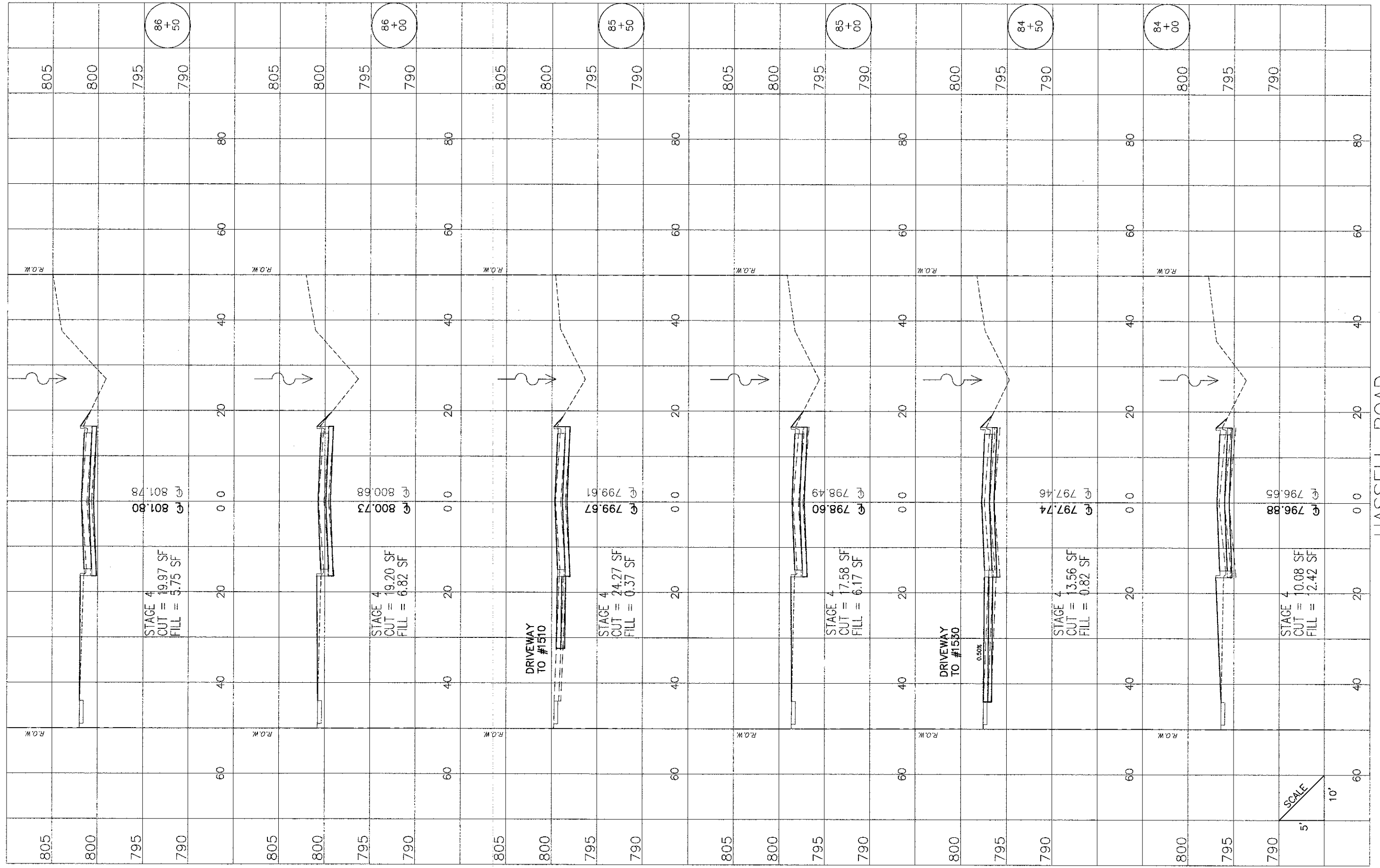

FILE NAME =
Hassell Plan-Profile.dwg

DESIGNED --	REVISED --
DRAWN --	REVISED --
CHECKED --	REVISED --
DATE --	REVISED --

**STATE OF ILLINOIS
DEPARTMENT OF TRANSPORTATION**

Hassell Road STP Project
Cross Sections

SHEET NO. 26 OF 27 SHEETS STA. 84+00 TO STA 86+50

F.A.U. RTE.	SECTION	COUNTY	TOTAL SHEETS	SHEET NO.
1100	11-00087-00-FP	Cook	164	163
CONTRACT NO. 63770			ILLINOIS FED. AID PROJECT CMM 9003(757)	

SCALE
5' 10'

HASSELL ROAD

PLAN	SURVEYED	PLOTTED	CHECKED
NOTE BOOK NO.	BY	DATE	BY

PROFILE	SURVEYED	DATE	BY	DATE
NOTE BOOK NO.	BY	DATE	BY	DATE

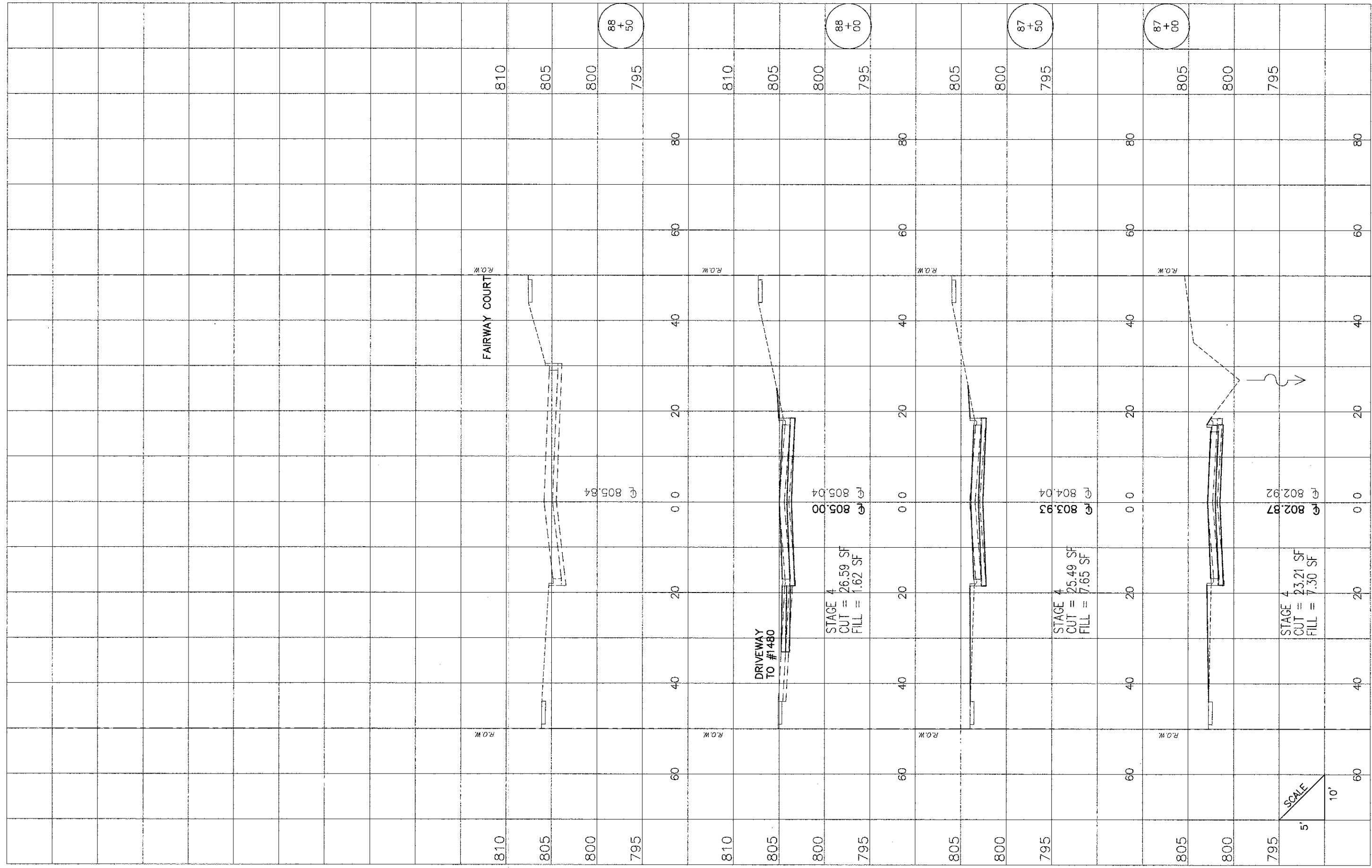

FILE NAME = Hassell Plan-Profile.dwg

DESIGNED -	REVISED -
DRAWN -	REVISED -
CHECKED -	REVISED -
DATE -	REVISED -

**STATE OF ILLINOIS
DEPARTMENT OF TRANSPORTATION**

Hassell Road STP Project
Cross Sections
SHEET NO. 27 OF 27 SHEETS STA. 87+00 TO STA 88+50

F.A.U. RTE.	SECTION	COUNTY	TOTAL SHEETS	SHEET NO.
1100	11-00087-00-FP	Cook	164	164
CONTRACT NO. 63770			ILLINOIS FED. AID PROJECT CMM 9003(757)	