

\* Cut bottom end of post to curb slope.

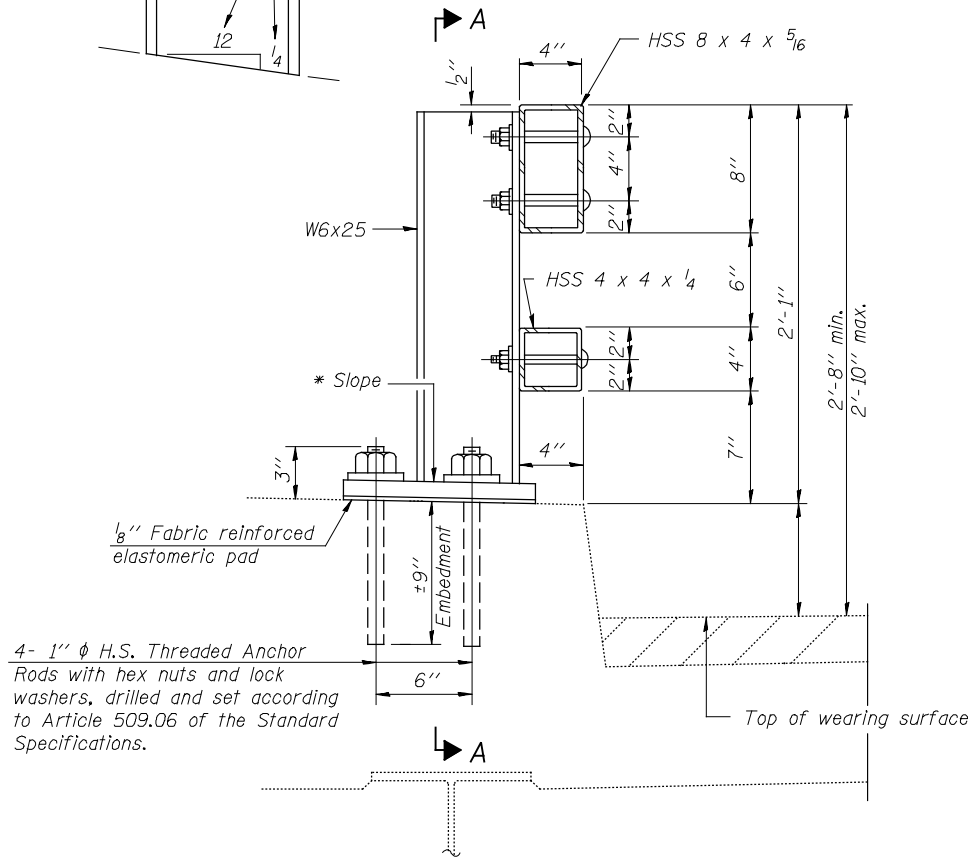

SECTION AT RAIL POST

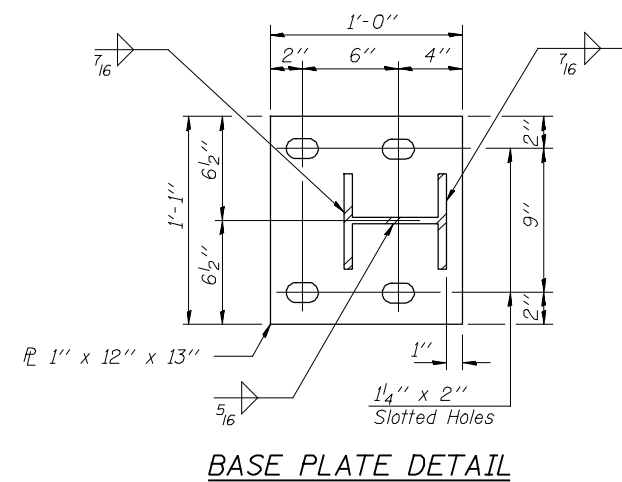

BASE PLATE DETAIL

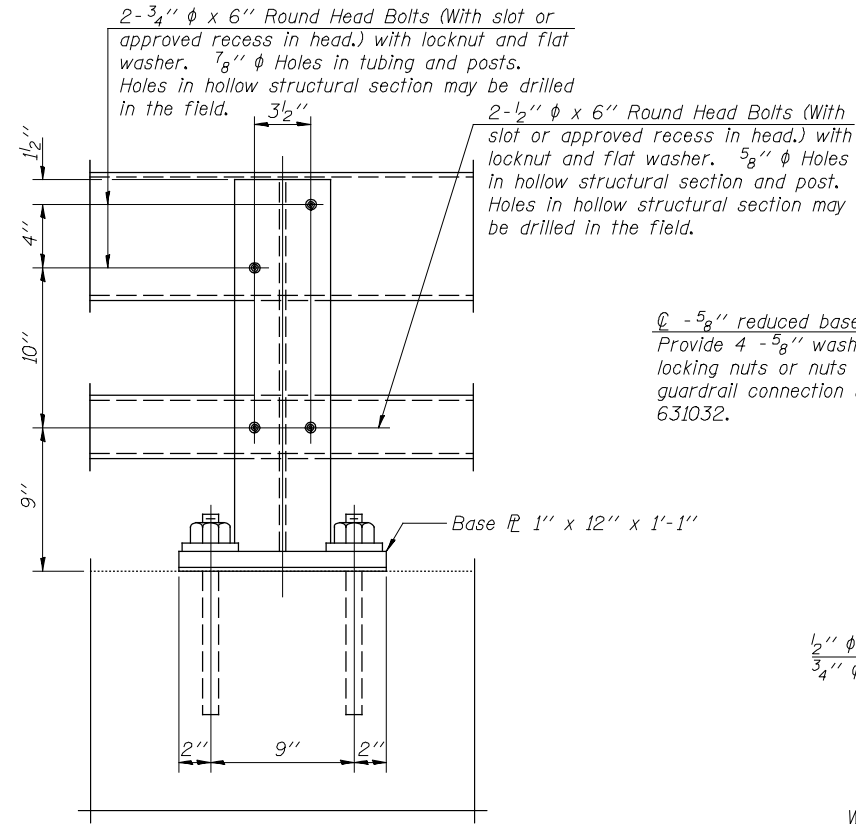

SECTION A-A

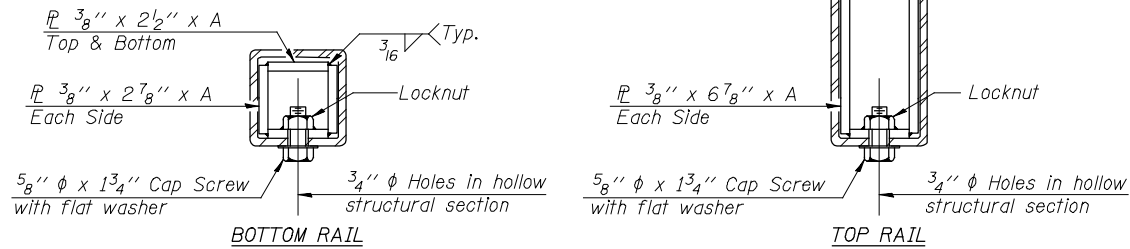

SECTIONS AT RAIL SPLICE

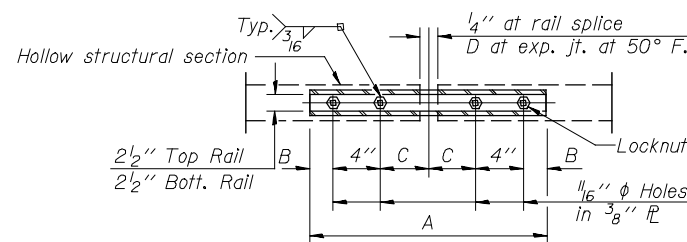

PLAN-BOTT. SPLICE TYPICAL

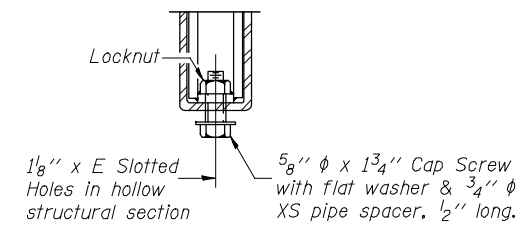

RAIL SPLICE CONNECTION AT EXPANSION JT.

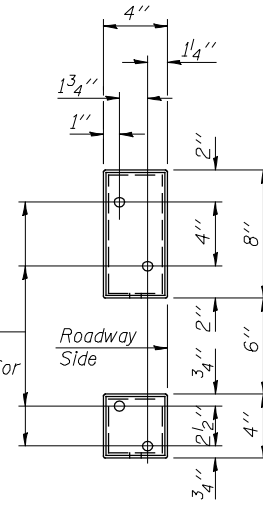

VIEW B-B

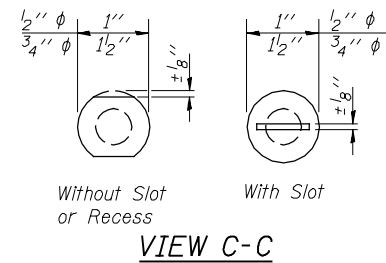

VIEW C-C

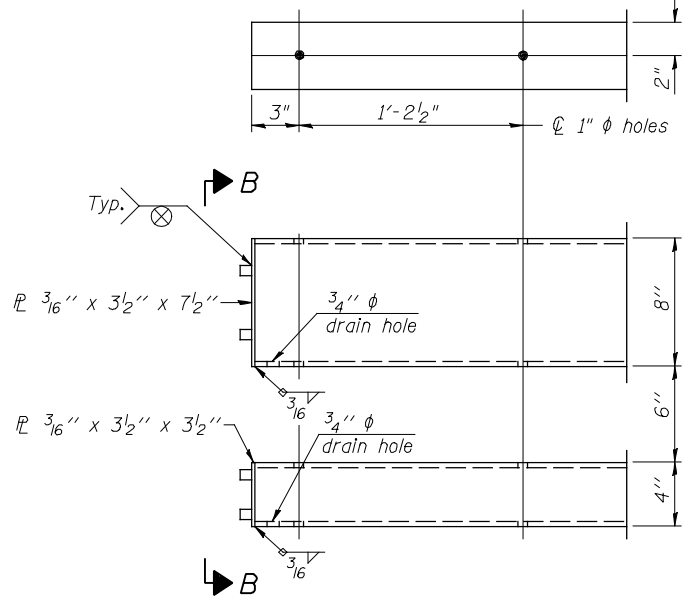

END OF RAIL DETAILS

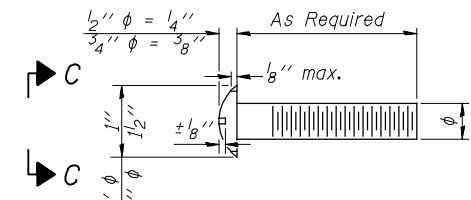

DETAIL OF 1/2 inch & 3/4 inch ROUND HEAD BOLTS

Notes:  
 All field drilled holes shall be coated with an approved zinc rich paint before erection.  
 Posts shall not be located closer than 1'-3" to an existing bridge expansion joint or end of bridge.  
 Steel Bridge Rail expansion joint shall be provided between any two (2) posts which span a bridge expansion joint. Bolts located at expansion joint shall be provided with locknuts and shall be tightened only to a point that will allow ralling movement.  
 Provide one 1/8" and two 1/16" steel shims for 25% of the posts. Shims shall be similar to base plates in size and holes.  
 All steel rail elements shall be galvanized according to Article 509.05 of the Standard Specifications.

SPLICE DIMENSIONS

T	D	A	B	C	E
≤4"	2 1/2"	1'-8"	2"	4"	2 1/2"
>4"≤6 1/2"	3 3/4"	2'-0"	2 1/2"	5 1/2"	3 1/2"
>6 1/2"≤9"	5"	2'-4"	3 1/2"	6 1/2"	9"
>9"≤13"	7"	2'-10"	4 1/2"	8 1/2"	11"
Rail Splice	1/4"	1'-8"	2"	4"	—

T = Total movement at expansion joint as shown on the design plans.

BILL OF MATERIAL

Item	Unit	Quantity
Steel Railing, Type 2399	Foot	192

R-31

7-1-10

(6'-3" Maximum Post Spacing)

FILE NAME = W:\Transportation\2891\Grading Plans\2891.dgn	USER NAME = jdeen	DESIGNED - JRB	REVISED -
PLOT SCALE = 100.0000' / IN.	CHECKED - AWM	DRAWN - JMO	REVISED -
PLOT DATE = 12/12/2012	DATE - 12-12-12		REVISED -

STATE OF ILLINOIS  
 DEPARTMENT OF TRANSPORTATION

FAP 407 (IL RTE 336)  
 STEEL RAILING, TYPE 2399

SCALE: N/A SHEET NO. 1 OF 1 SHEETS STA. TO STA.

F.A.P. RTE.	SECTION	COUNTY	TOTAL SHEETS	SHEET NO.
407	(55-3)A	McDONOUGH	671	308
ILLINOIS FED. AID PROJECT			CONTRACT NO. 68A42	