

**DETAILS OF MAILBOX TURNOUTS**

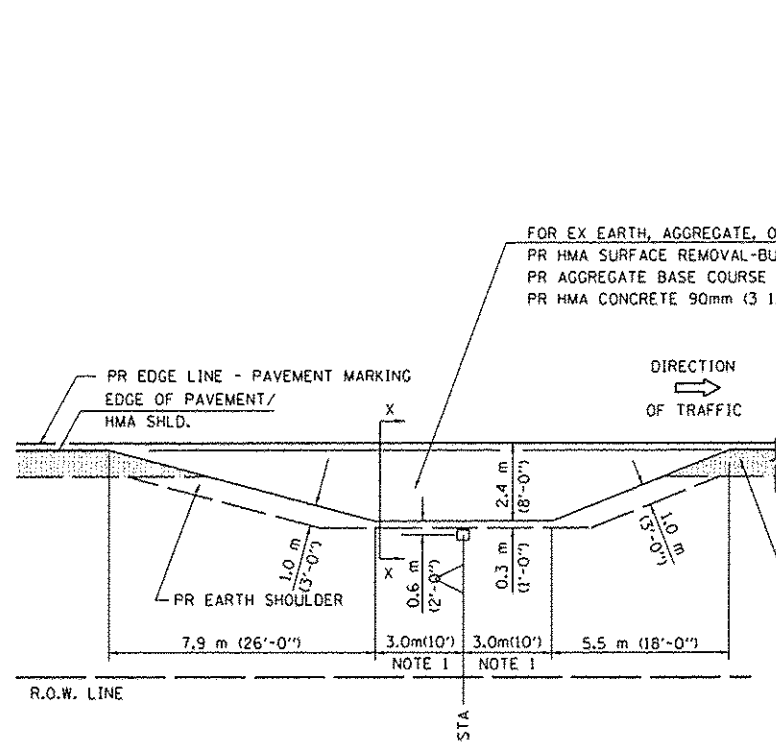

**PLAN - MAILBOX TURNOUTS**

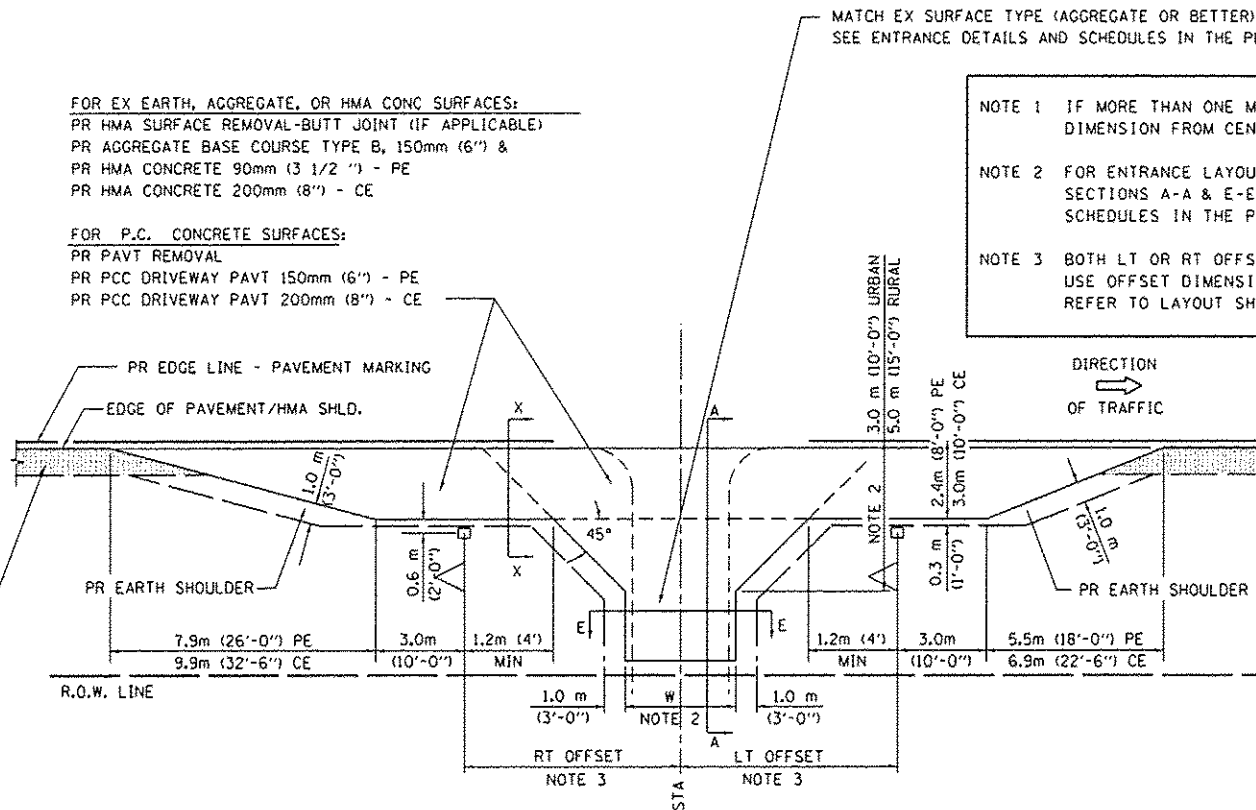

**PLAN - COMBINED MAILBOX TURNOUT WITH TRAILING OR LEADING ENTRANCE**

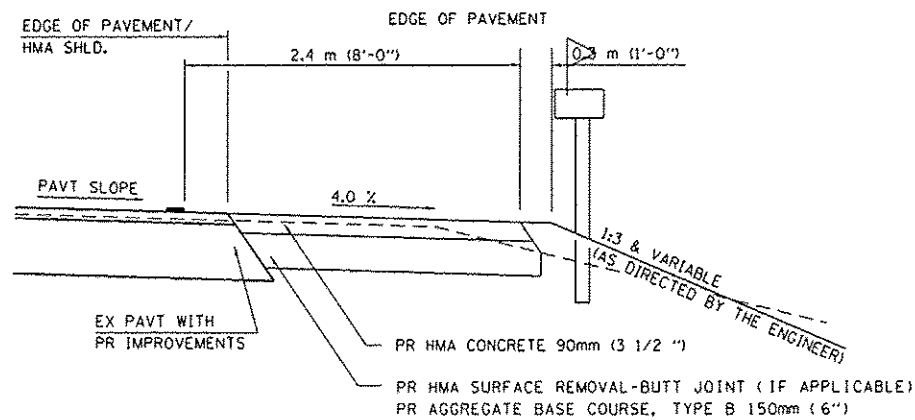

**SECTION X-X THRU MAILBOX TURNOUT  
ALSO APPLIES TO MAILBOX TURNOUTS COMBINED WITH  
EX EARTH, AGGREGATE, OR HMA PE & FE**

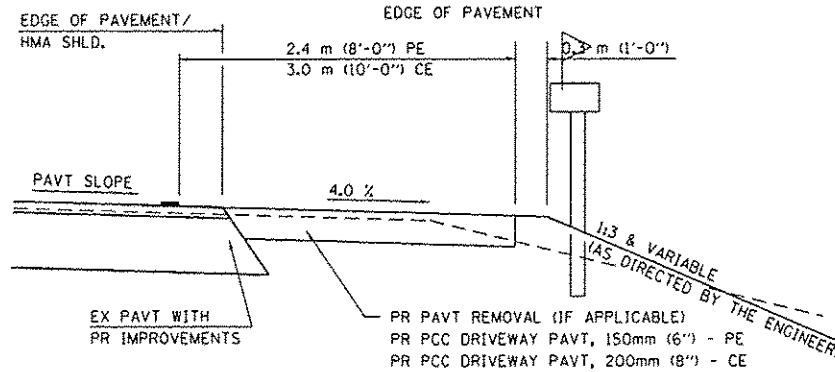

**SECTION X-X THRU MAILBOX TURNOUT  
COMBINED WITH EX CONC PE OR CE**

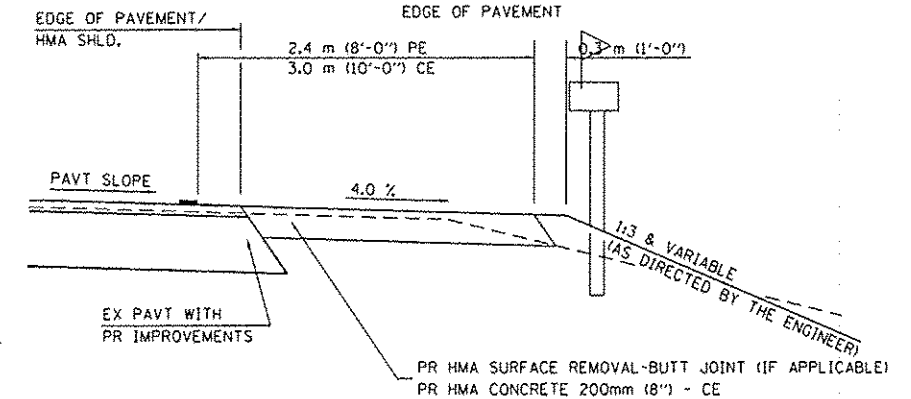

**SECTION X-X THRU MAILBOX TURNOUT  
COMBINED WITH EX EARTH, AGGREGATE, OR HMA CE**

FOR EX EARTH, AGGREGATE, OR HMA CONC SURFACES:  
PR HMA SURFACE REMOVAL-BUTT JOINT (IF APPLICABLE)  
PR AGGREGATE BASE COURSE TYPE B, 150mm (6") &  
PR HMA CONCRETE 90mm (3 1/2 ") - PE  
PR HMA CONCRETE 200mm (8") - CE

FOR P.C. CONCRETE SURFACES:  
PR PAVT REMOVAL  
PR PCC DRIVEWAY PAVT 150mm (6") - PE  
PR PCC DRIVEWAY PAVT 200mm (8") - CE

FOR EX EARTH, AGGREGATE, OR HMA CONC SURFACES:  
PR HMA SURFACE REMOVAL-BUTT JOINT (IF APPLICABLE)  
PR AGGREGATE BASE COURSE TYPE B, 150mm (6")  
PR HMA CONCRETE 90mm (3 1/2 ")

MATCH EX SURFACE TYPE (AGGREGATE OR BETTER)  
SEE ENTRANCE DETAILS AND SCHEDULES IN THE PLANS

- NOTE 1 IF MORE THAN ONE MAILBOX IS PRESENT, DIMENSION FROM CENTER OF END MAILBOX.
- NOTE 2 FOR ENTRANCE LAYOUT DIMENSIONS AND SECTIONS A-A & E-E REFER TO THE SCHEDULES IN THE PLANS.
- NOTE 3 BOTH LT OR RT OFFSETS FOR MAILBOX SHOWN USE OFFSET DIMENSION PER SCHEDULE AND REFER TO LAYOUT SHOWN ON THE PLAN.

**REVISION** **REVISED SHEET 2-28-2013**

FILE NAME c:\pwwork\pwwork\sporksg\d0329805\067062-sht-details2.dgn	USER NAME sporksg	DESIGNED -	REVISED 2/19/03 (JCN)	<b>STATE OF ILLINOIS DEPARTMENT OF TRANSPORTATION</b>	<b>DISTRICT 6 DETAILS FOR RURAL/URBAN ENTRANCE &amp; MAILBOX TURNOUT W/O CONC GUTTER (3R - PROJECTS)</b>	F.A.P. RTE. 685	SECTION 113B-4	COUNTY HANCOCK	TOTAL SHEETS 57	SHEET NO. 44		
ENT 3R.DGN	PLOT SCALE 40.0000 "/ in.	DRAWN CADD	REVISED 4/01/04 (JCN)			SCALE:	SHEET NO. 2 OF 3 SHEETS	FED. ROAD DIST. NO.	ILLINOIS/FED. AID PROJECT	CONTRACT NO. 72B62		
	PLOT DATE Dec-10-2012 10:20:00AM	CHECKED JCN	REVISED 8/01/07 (JCN)			STA.	TO STA.					
		DATE FEBRUARY 23, 1999	REVISED -									