

ELEVATION AT SOUTH ABUT.

SECTION A-A

TYPE I ELASTOMERIC EXP. BRG.  
(At South Abutment - 4 Required)

Notes:  
Anchor bolts shall be ASTM F1554 all-thread (or an Engineer-approved alternate material) of the grade(s) and diameter(s) specified. ASTM A307 Grade C anchor bolts may be used in lieu of ASTM F1554 Grade 36 (Fy=36ksi). The corresponding specified grade of AASHTO M314 anchor bolts may be used in lieu of ASTM F1554.  
Anchor bolts for side retainers may be cast in place or installed in holes drilled before or after members are in place.  
Drilled and set anchor bolts shall be installed according to Article 521.06 of the Standard Specifications.  
Side retainers and other steel members required for the bearing assembly shall be included in the cost of Elastomeric Bearing Assembly, Type I.

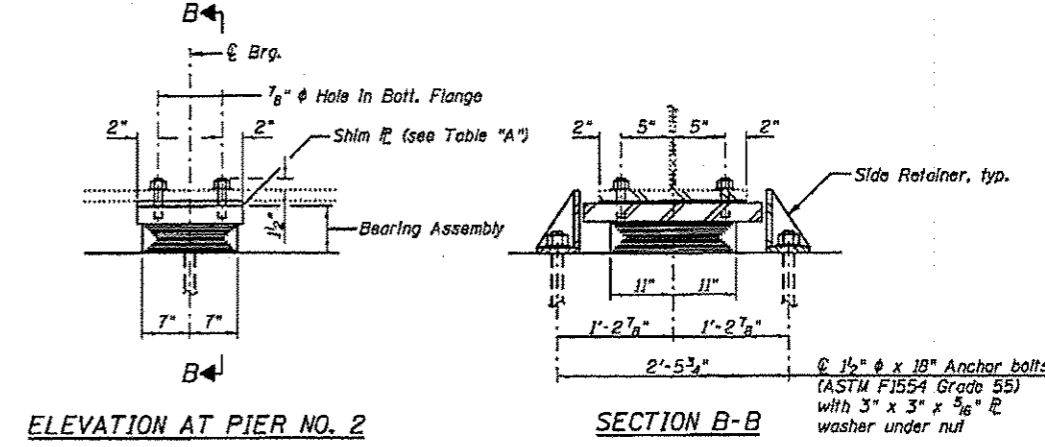

ELEVATION AT PIER NO. 2

SECTION B-B

TYPE I ELASTOMERIC EXP. BRG.  
(At Pier No. 2 - 4 Required)

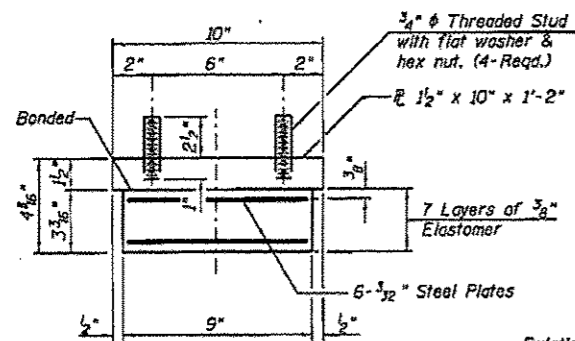

BEARING ASSEMBLY

Note: Shim plates shall not be placed under Bearing Assembly.

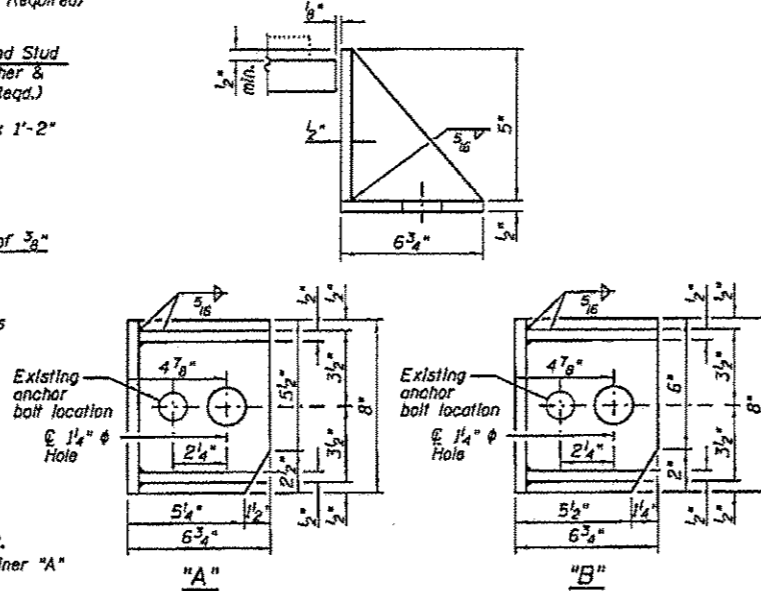

MODIFIED SIDE RETAINER

Equivalent rolled angle with stiffeners will be allowed in lieu of welded plates.

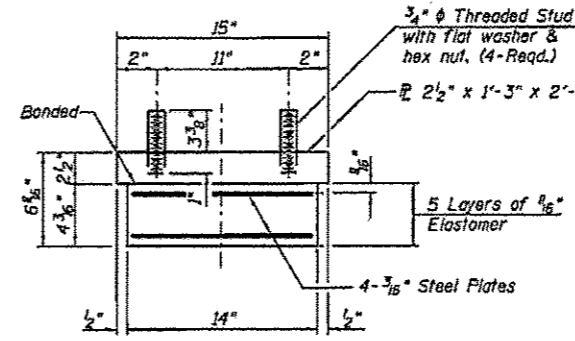

BEARING ASSEMBLY

Note: Shim plates shall not be placed under Bearing Assembly.

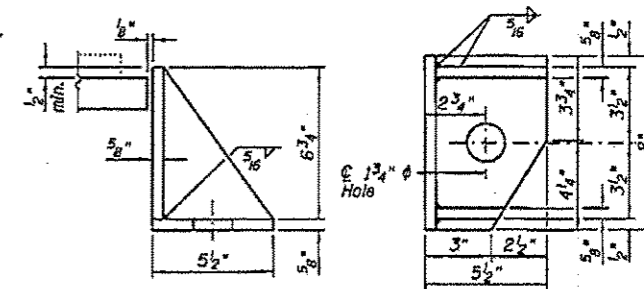

MODIFIED SIDE RETAINER "C"

Equivalent rolled angle with stiffeners will be allowed in lieu of welded plates.

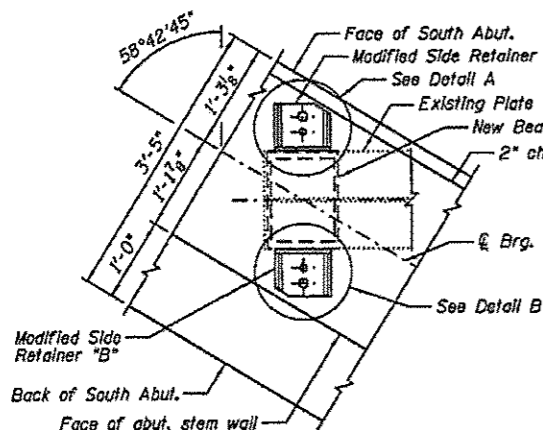

BEARING PLAN AT SOUTH ABUTMENT

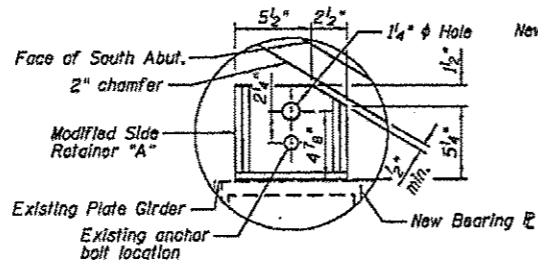

DETAIL A

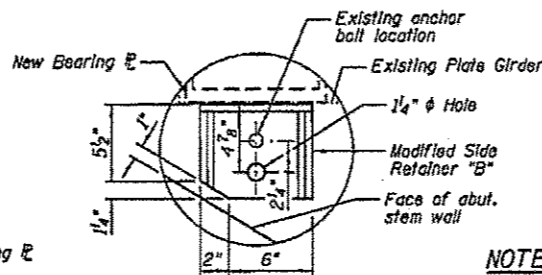

DETAIL B

NOTE:

Two 1/2 in. adjusting shims shall be provided for each bearing in addition to all other plates or shims and placed as shown on bearing details.

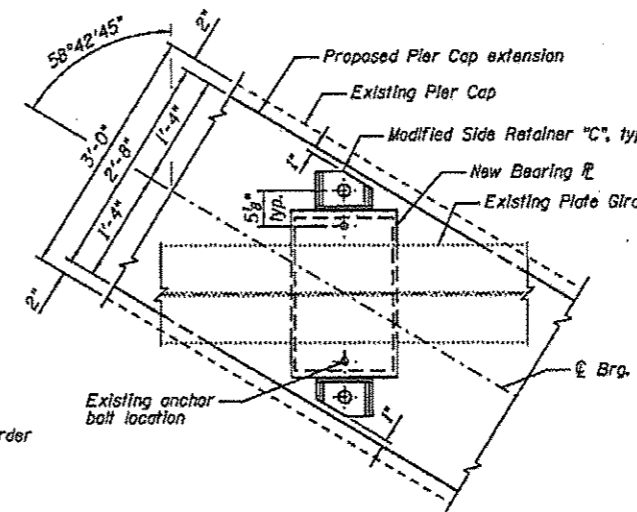

BEARING PLAN AT PIER NO. 2

BILL OF MATERIAL

Item	Unit	Total
Erecting Elastomeric Bearing Assembly, Type I	Each	8
Anchor Bolts, 1"	Each	8
Anchor Bolts, 1 1/2"	Each	8

TABLE "A"

Location/Girder No.	Shim Thickness
South Abut./3	1/2"
South Abut./5	3/8"
Pier No. 2/2	1/4"

EXISTING GIRDER TYPE I  
BEARING DETAILS  
STRUCTURE NO.084-0028

FOR INFORMATION ONLY

FILE NAME *	USER NAME * mcdonalds	DESIGNED -	REVISED -	STATE OF ILLINOIS DEPARTMENT OF TRANSPORTATION	BEARING DETAILS	F.A.I. RTE.	SECTION	COUNTY	TOTAL SHEETS	SHEET NO.	
c:\documents and settings\mcdonalds\desktop\plansheet.dgn		DRAWN -	REVISED -			55	06 PAINTING 2013	SANGAMON	26	13	
		CHECKED -	REVISED -			CONTRACT NO. 72FBS					
Default		DATE -	REVISED -			[ILLINOIS] FED. AID PROJECT					