

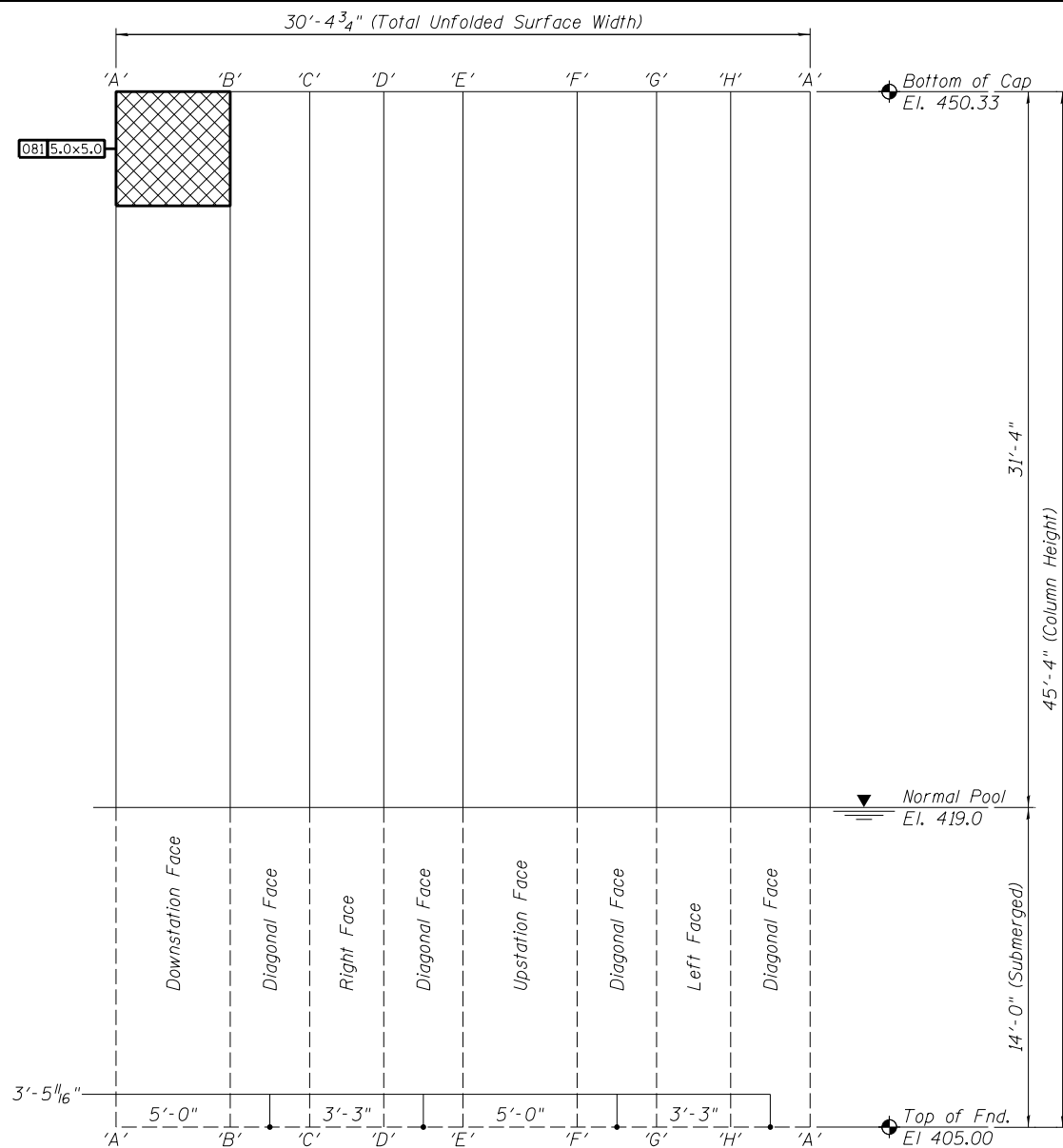

© Copyright Hanson Professional Services Inc. 2012

huffm0028 10/17/2012 12:06:58 PM
 I:\Jobs\110007\W04\CAD\SH000255-76E73-024-Pier-4_Column_Repair.sgn



PIER NO. 4 - ELEVATION - LEFT COLUMN
Column Surface Shown Unfolded

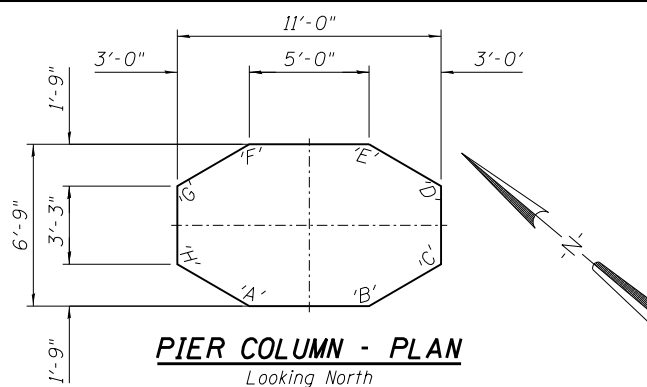

PIER COLUMN - PLAN
Looking North

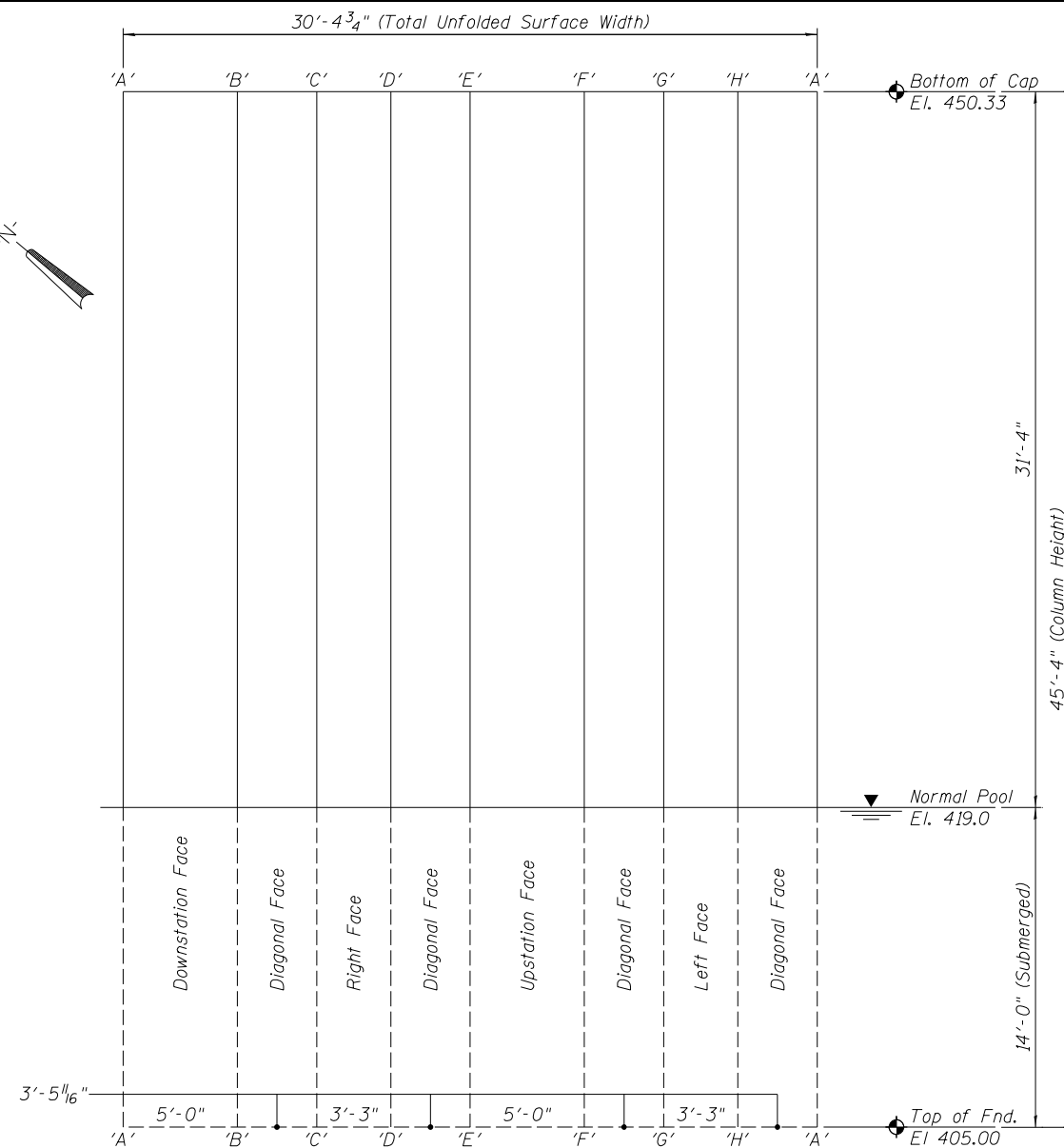

PIER NO. 4 - ELEVATION - RIGHT COLUMN
Column Surface Shown Unfolded

REPAIRS LIST - PIER 4 - COLUMNS

I.D.	Description	Pay Item	Units	Quantity
081	Map Cracking	Concrete Sealer	SQ. FT.	25.0
-	-	-	-	-
-	-	-	-	-
-	-	-	-	-

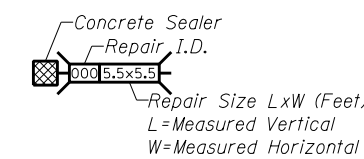

CONCRETE SEALER

DESIGNED -	EXAMINED _____	DATE - _____
CHECKED -	ENGINEER OF STRUCTURAL SERVICES	
DRAWN Rod	PASSED _____	
CHECKED MNM	ENGINEER OF BRIDGES AND STRUCTURES	

**STATE OF ILLINOIS
DEPARTMENT OF TRANSPORTATION**

**REPAIRS TO - PIER NUMBER 4 - COLUMNS
STRUCTURE NO. 060-0255**

SHEET NO. 24 OF 48 SHEETS

F.A.P. RTE.	SECTION	COUNTY	TOTAL SHEETS	SHEET NO.
304	100B-1D5-1	MADISON	58	34
CONTRACT NO. 76E73				

ILLINOIS FED. AID PROJECT