

PIER NO. 8 - ELEVATION - LEFT COLUMN
 Column Surface Shown Unfolded

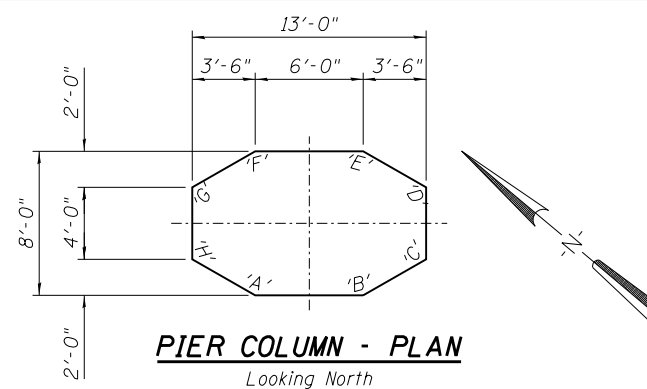

PIER COLUMN - PLAN
 Looking North

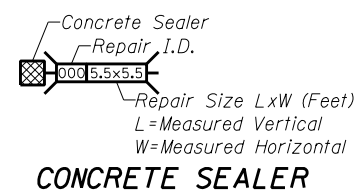

CONCRETE SEALER

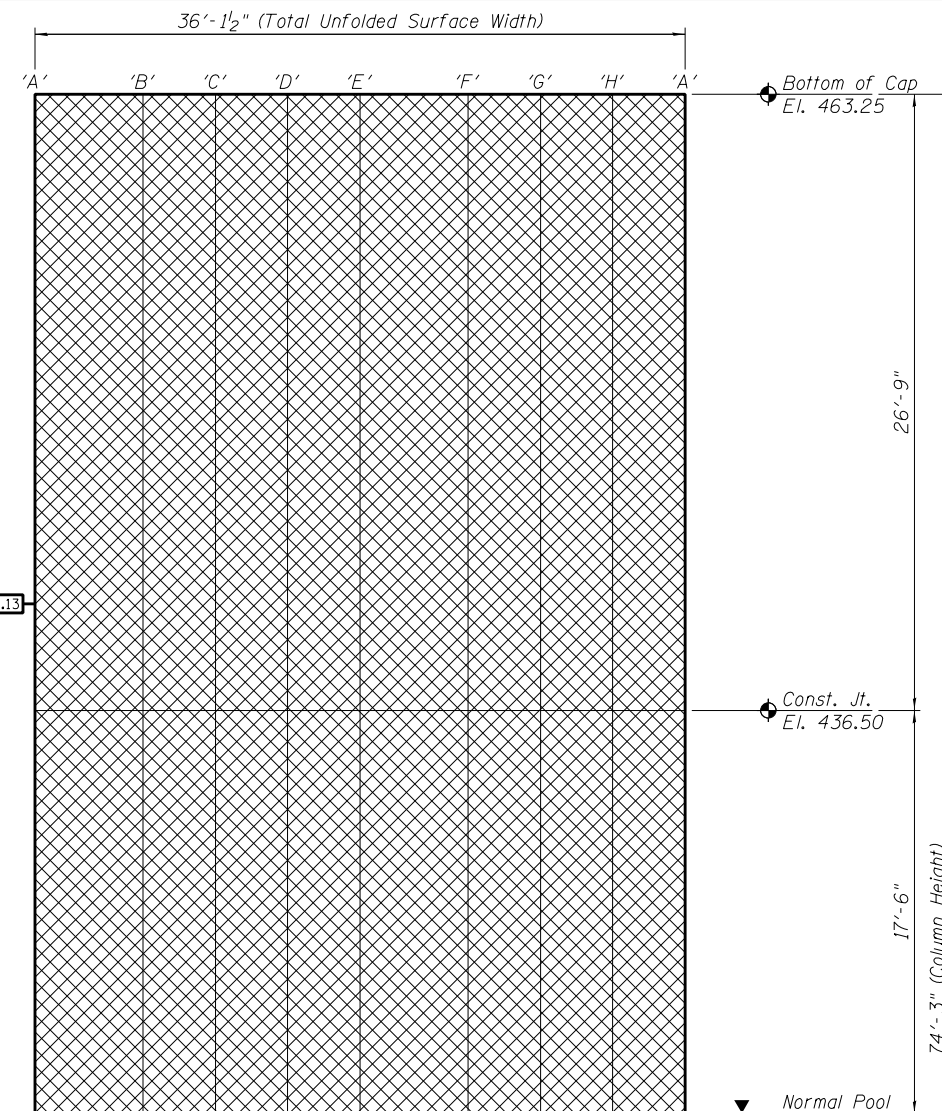

PIER NO. 8 - ELEVATION - RIGHT COLUMN
 Column Surface Shown Unfolded

REPAIRS LIST - PIER 8 - COLUMNS

I.D.	Description	Pay Item	Units	Quantity
085	Map Cracking	Concrete Sealer	SQ. FT.	1598.8
086	Map Cracking	Concrete Sealer	SQ. FT.	1598.8
-	-	-	-	-
-	-	-	-	-
-	-	-	-	-
-	-	-	-	-
-	-	-	-	-

DESIGNED -	EXAMINED _____	DATE - _____
CHECKED -	ENGINEER OF STRUCTURAL SERVICES	
DRAWN Rod	PASSED _____	
CHECKED MNM	ENGINEER OF BRIDGES AND STRUCTURES	

**STATE OF ILLINOIS
 DEPARTMENT OF TRANSPORTATION**

**REPAIRS TO - PIER NUMBER 8 - COLUMN
 STRUCTURE NO. 060-0255**

SHEET NO. 29 OF 48 SHEETS

F.A.P. RTE.	SECTION	COUNTY	TOTAL SHEETS	SHEET NO.
304	100B-IDS-1	MADISON	58	39
CONTRACT NO. 76E73				

ILLINOIS FED. AID PROJECT