

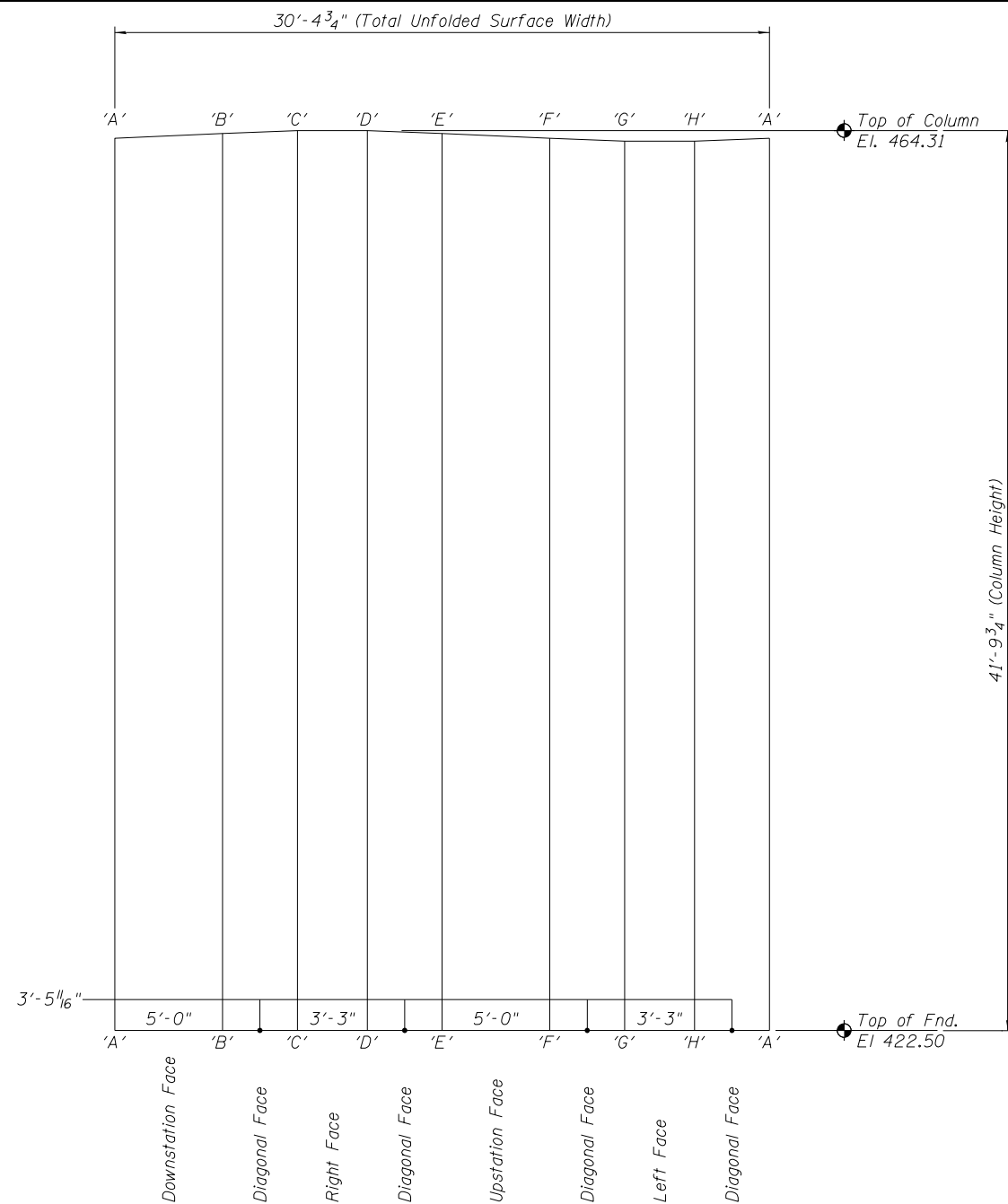

© Copyright Hanson Professional Services Inc. 2012

huffm00028 10/17/2012 12:09:07 PM
 I:\Jobs\110007\MOA\CAD\SHETS\0600255-76E73-039-Pier-14_Column_Repair.scdgn



PIER NO. 14 - ELEVATION - LEFT COLUMN
 Column Surface Shown Unfolded

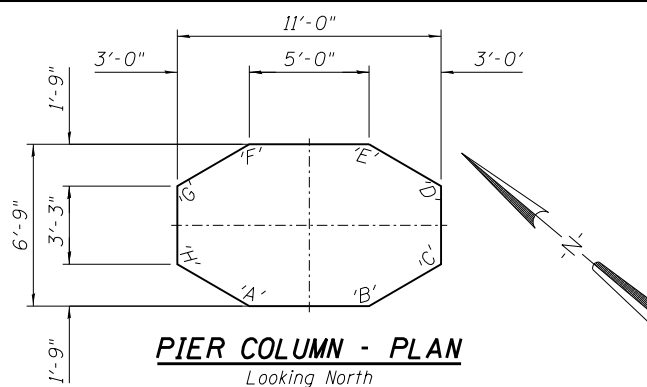

PIER COLUMN - PLAN
 Looking North

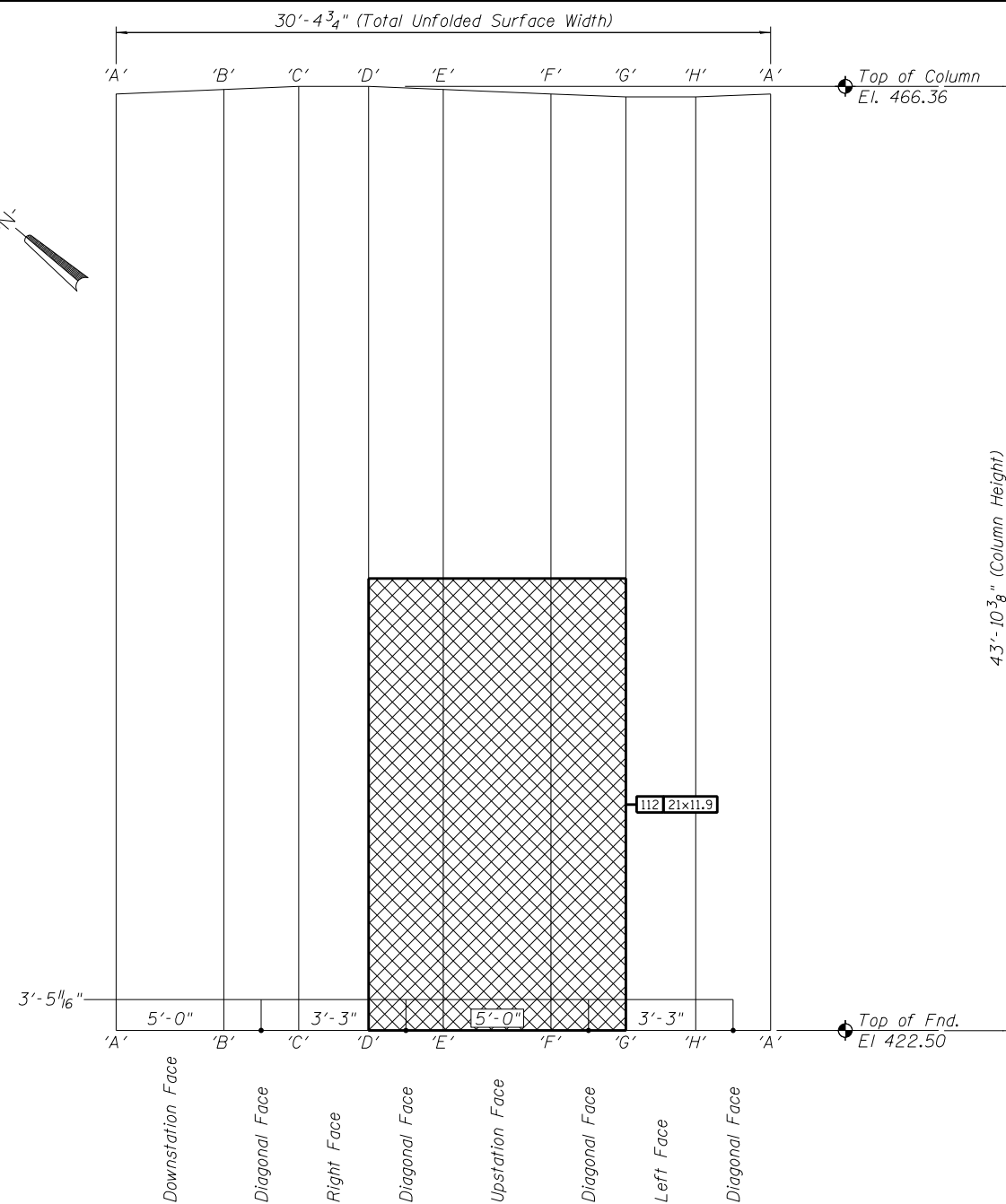

PIER NO. 14 - ELEVATION - RIGHT COLUMN
 Column Surface Shown Unfolded

REPAIRS LIST - PIER 14 - COLUMNS

I.D.	Description	Pay Item	Units	Quantity
112	Map Cracking	Concrete Sealer	SQ. FT.	249.9
-	-	-	-	-
-	-	-	-	-
-	-	-	-	-
-	-	-	-	-
-	-	-	-	-
-	-	-	-	-

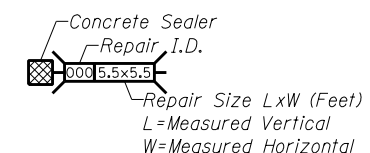

CONCRETE SEALER

DESIGNED -	EXAMINED _____	DATE - _____
CHECKED -	ENGINEER OF STRUCTURAL SERVICES	
DRAWN Rod	PASSED _____	
CHECKED MNM	ENGINEER OF BRIDGES AND STRUCTURES	

**STATE OF ILLINOIS
 DEPARTMENT OF TRANSPORTATION**

**REPAIRS TO - PIER NUMBER 14 - COLUMNS
 STRUCTURE NO. 060-0255**

SHEET NO. 39 OF 48 SHEETS

F.A.P. RTE.	SECTION	COUNTY	TOTAL SHEETS	SHEET NO.
304	100B-IDS-1	MADISON	58	49
CONTRACT NO. 76E73				
ILLINOIS FED. AID PROJECT				