

Point modified for clarity.
2122113

TWP. NO.	SEC.	COUNTY	TOTAL SHEETS	SHEET NO.
61	*	DEKALB	18	9
ILLINOIS PROJECT BROS-0037(051)				
* 08-18121-00-BR				
CONTRACT NO. 67487				

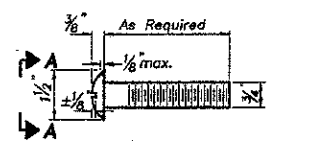

DETAIL OF 3/4" ROUND HEAD BOLT

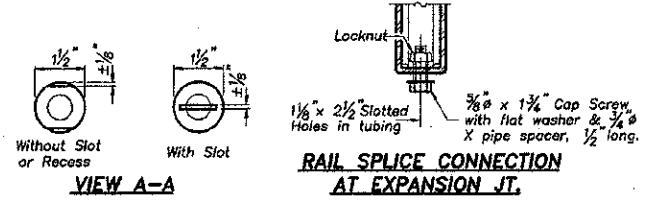

RAIL SPLICE CONNECTION AT EXPANSION JT.

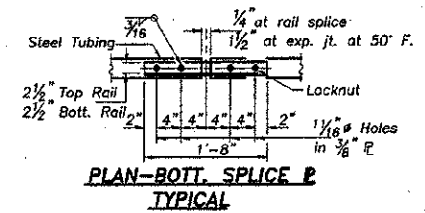

PLAN-BOTT. SPLICE P TYPICAL

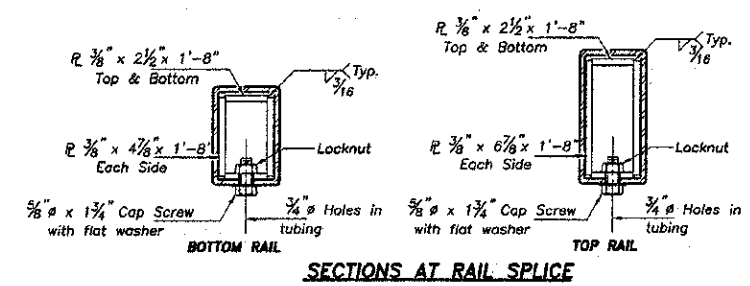

SECTIONS AT RAIL SPLICE

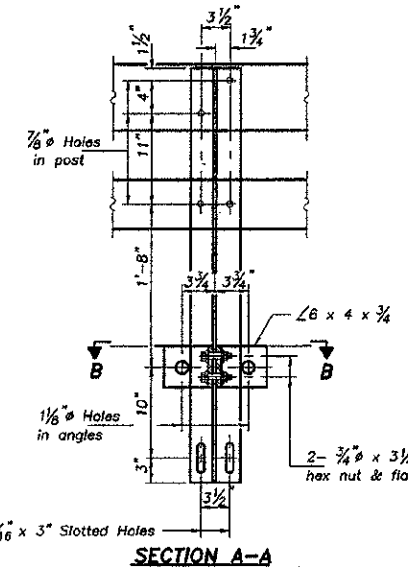

SECTION A-A

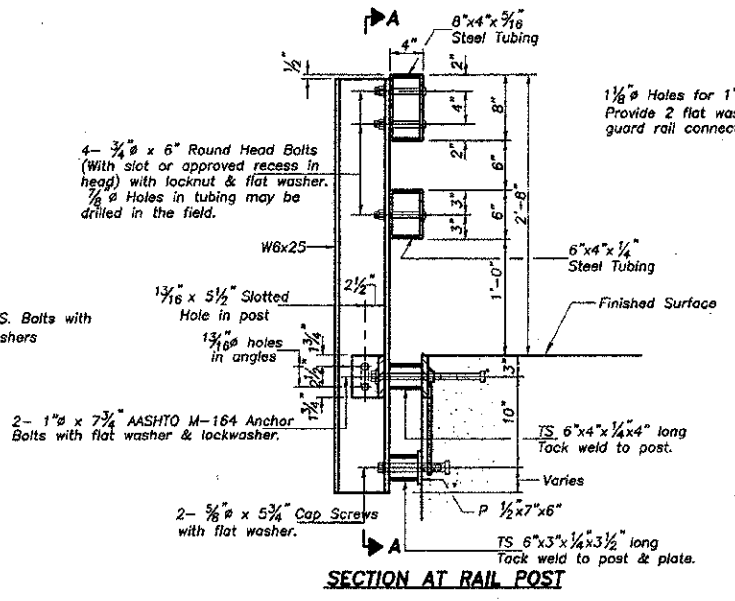

SECTION AT RAIL POST

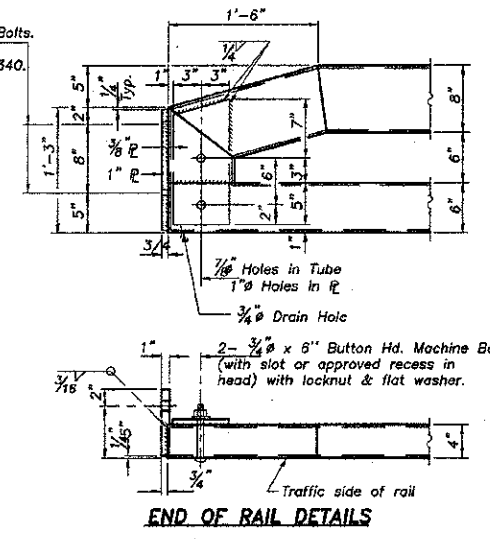

END OF RAIL DETAILS

GENERAL NOTES

Hollow structural steel tubing shall conform to the requirements of ASTM designation A-500 Grade B Structural Steel Tubing and shall meet the longitudinal CVN requirements of 15 ft-lbs at 0° F. All other steel shapes and plates shall conform to the requirements of AASHTO M-270 Grade 36 except posts and angles shall conform to AASHTO M-270, Grade 50. Bolts, cap screws, and nuts shall conform to the requirement of ASTM designation A-307 except for high strength bolts, nuts and washers which shall conform to AASHTO M-164. All bolts, nuts, cap screws, washers and lock washers shall be galvanized in accordance with AASHTO M-232. All posts, railing, rail splices, anchor devices and angles shall be galvanized after shop fabrication in accordance with AASHTO M-111 and ASTM A-385. Galvanized rail shall not be painted. Railing shall be in accordance with Section 509 of the Standard Specifications, except as noted, and will be paid for at the contract unit price per foot for STEEL BRIDGE RAIL, TYPE SM. All field drilled holes shall be coated with an approved zinc rich paint before erection. For multi-span PPC Deck bridges, sufficient 1/4" x 6" x 1-2" galvanized steel shims shall be provided to align rail between adjacent spans. Cost incidental to STEEL BRIDGE RAIL, TYPE SM. Bolts located at expansion joint shall be provided with locknuts and shall be tightened only to a point that will allow railing movement. The 3/4" high strength bolts used to connect the 6 x 4 x 3/4 angles to the post shall be tightened in accordance with Article 505.04(1)(3) of the Standard Specifications. The 1" high strength bolts connecting the angles to the concrete shall be tightened to a snug fit and given an additional 1/8 turn. The 5/8" cap screws in bottom of posts shall be tightened to a snug fit only.

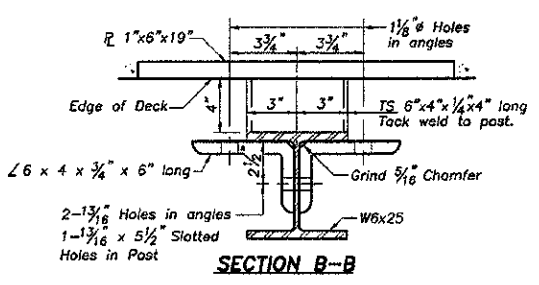

SECTION B-B

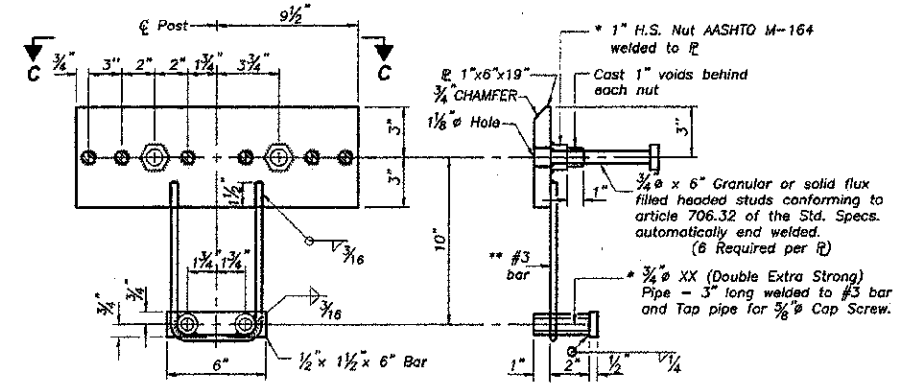

ANCHOR DEVICE

* Threaded areas shall be plugged or blocked off during casting of beam Galvanized after fabrication.
** Whenever the lower insert assemblies interfere with strand locations, the #3 bars shall be cut and adjusted in order to allow raising or lowering of the lower inserts. Maximum adjustment not to exceed 1/2".

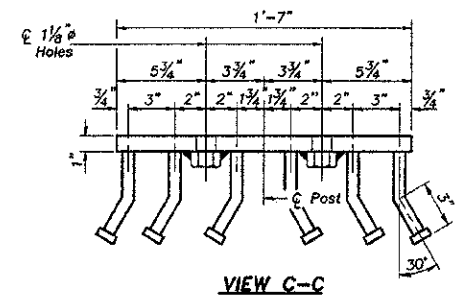

VIEW C-C

BILL OF MATERIAL

Item	Unit	Quantity
Steel Bridge Rail, Type SM	Foot	369

TYPE SM
STEEL BRIDGE RAIL SIDE MOUNTED
SECTION 08-18121-00-BR
BASE LINE ROAD
DEKALB COUNTY
SN 019-4500

DESIGNED:	RLR
DRAWN:	BDS
CHECKED:	
DATE:	

R-34 7-1-94 (6'-3" Maximum Post Spacing)

REVISIONS

NO.	DATE	DESCRIPTION

wendler
CONCRETE REINFORCING SOLUTIONS
ENGINEERS ARCHITECTS SURVEYORS
www.wendlereng.com ph: 816.288.2261
Missouri Professional Design Firm No. 164-00046

TYPE SM RAIL DETAILS
OF
BASE LINE ROAD BRIDGE PROJECT
FOR
DEKALB COUNTY HIGHWAY

SHEET TITLE
RAIL DETAILS

JOB NUMBER	2060392
DATE	12/14/2012
SHEET NO.	9 of 18