

SUMMARY OF QUANTITIES
FUNDING CODE: X071-2A

TWP. R.F.E. NO.	SEC.	COUNTY	TOTAL SHEETS	SHEET NO.
61	*	DEKALB	18	2
ILLINOIS PROJECT BROS-0037(051)				
* 08-18121-00-BR				
CONTRACT NO. 87467				

CODE NUMBER	ITEM	UNIT	TOTAL QUANTITY
50101500	REMOVAL OF EXISTING SUPERSTRUCTURES	EACH	1
50300225	CONCRETE STRUCTURES	CU YD	9.3
50300255	CONCRETE SUPERSTRUCTURE	CU YD	145.5
50300260	BRIDGE DECK GROOVING	SQ YD	611.2
50300300	PROTECTIVE COAT	SQ YD	665.5
50500105	FURNISHING AND ERECTING STRUCTURAL STEEL	L SUM	1
50500505	STUD SHEAR CONNECTORS	EACH	2700
50800205	REINFORCEMENT BARS, EPOXY COATED	POUND	38,690
Δ 50901050	STEEL RAILING, TYPE SM	FOOT	369
51500100	NAME PLATES	EACH	1
52100010	ELASTOMERIC BEARING ASSEMBLY, TYPE I	EACH	15
67100100	MOBILIZATION	L SUM	1
70101830	TRAFFIC CONTROL AND PROTECTION, STANDARD BLR 21	L SUM	1
Z0012155	STRUCTURAL REPAIR OF CONCRETE (DEPTH > 5 IN.)	SQ FT	21
Z0013154	STRUCTURAL REPAIR OF CONCRETE (DEPTH ≤ 5 IN.)	SQ FT	30

QUANTITY NOTES:
Δ SPECIALTY ITEMS
SEE SPECIAL PROVISIONS

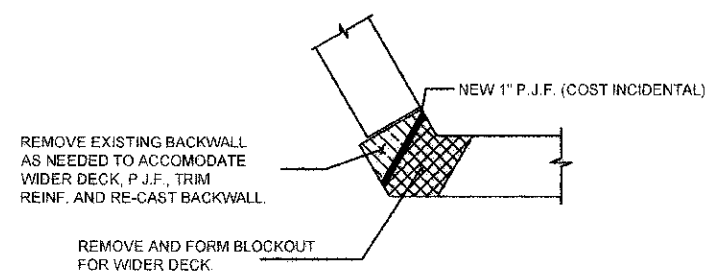
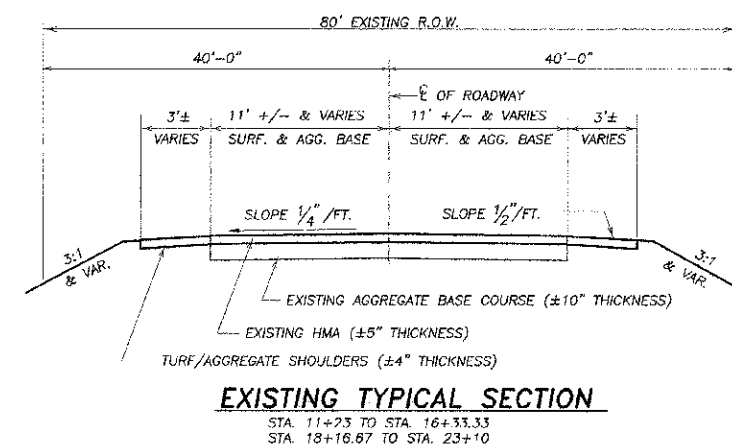

NOTE:
COSTS ASSOCIATED WITH MODIFYING THE BACKWALL TO ACCOMMODATE THE NEW DECK SHALL BE INCIDENTAL TO THE COST OF THE PROJECT. SEE STRUCTURAL REPAIR OF CONCRETE DETAILS FOR ADDITIONAL INFO.

SHORT WINGWALL MODIFICATIONS

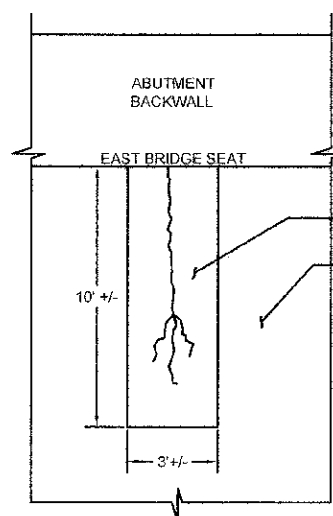

STRUCTURAL REPAIR OF CONCRETE (DEPTH ≤ 5 IN.) - 30 SQ. FT.

- NOTES:**
- ALL EXISTING DIMENSIONS TO BE FIELD VERIFIED.
 - LIMITS OF REPAIR AREAS SHALL BE AS DIRECTED BY THE ENGINEER IN THE FIELD.
 - CONCRETE REPAIRS SHALL BE COMPLETED PRIOR TO CONSTRUCTION OF THE NEW SUPERSTRUCTURE.
 - EARTH EXCAVATION AND BACKFILL BEHIND WINGWALLS REQUIRED FOR CONCRETE REPAIR SHALL BE INCIDENTAL TO THE COST OF STRUCTURAL REPAIR OF CONCRETE. BACKFILL SHALL BE CA18 OR EXISTING FILL MATERIALS, IF APPROVED BY THE COUNTY.

STRUCTURAL REPAIR OF CONCRETE DETAILS

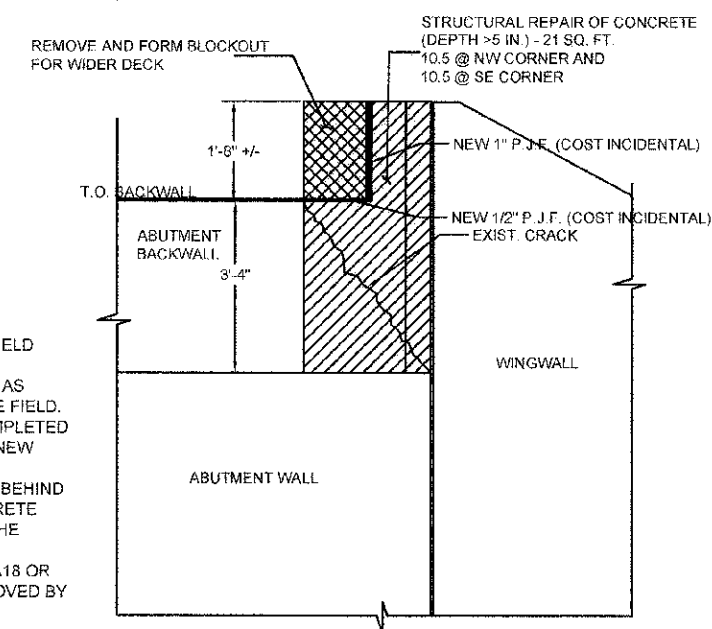
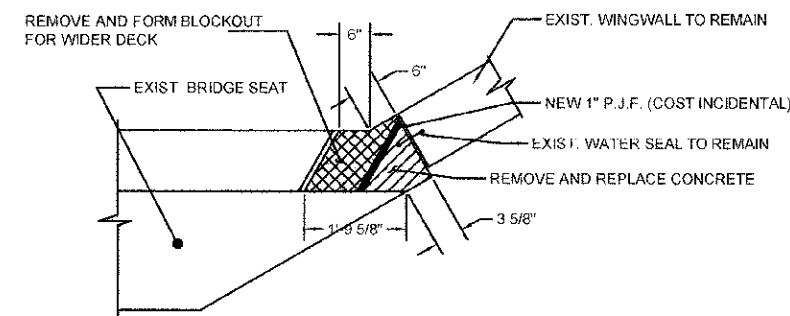

SUMMARY OF QUANTITIES SECTION 08-18121-00-BR
BASE LINE ROAD DEKALB COUNTY

REVISION	DATE	BY

wendler
GROUND-BREAKING SOLUTIONS
engineers, surveyors - scientists
www.wendlergs.com ph: 815.258.2261
Illinois Professional Design Firm No. 134-00848

SUMMARY OF QUANTITIES AND DETAILS
OF
BASE LINE ROAD BRIDGE PROJECT
FOR
DEKALB COUNTY HIGHWAY

SHEET TITLE
SUMMARY

JOB NUMBER
2080362

DATE
12/14/2012

SHEET NO.

2 of 18