

1/2" FABRIC BEARING PAD (Interior) 10 required
1/2" FABRIC BEARING PAD (Exterior) 4 required
FIXED

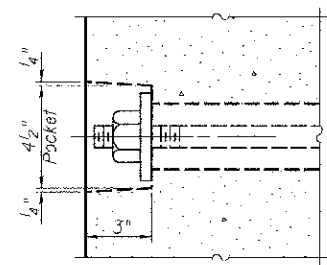

SECTION A-A

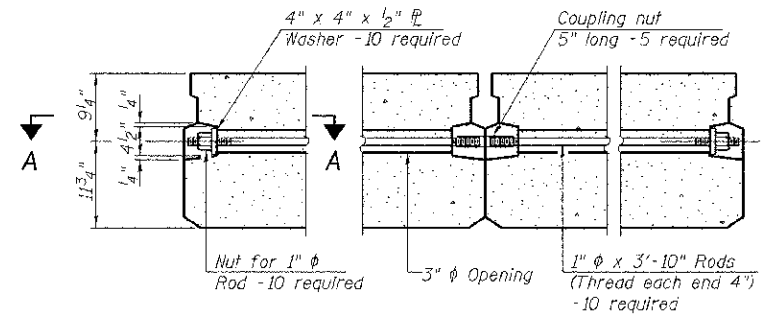

TYPICAL TRANSVERSE TIE ASSEMBLY

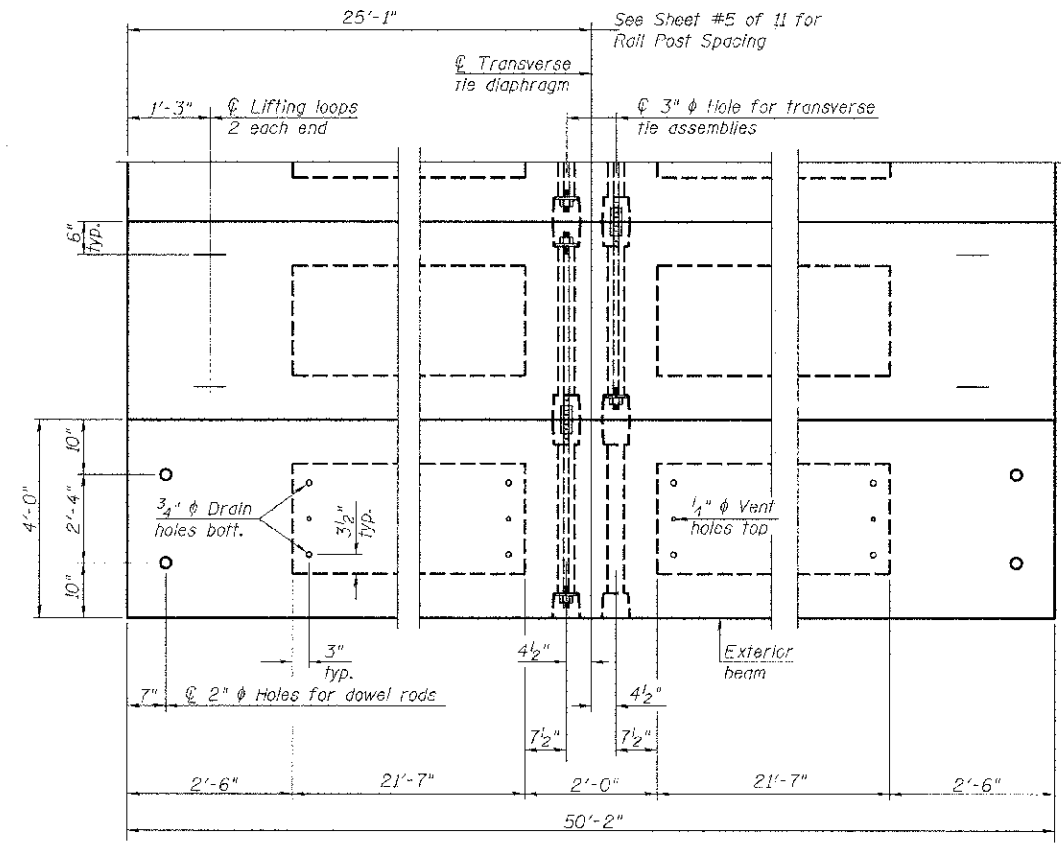

PLAN VIEW

Note: Connect beams in pairs with the transverse tie configuration shown.

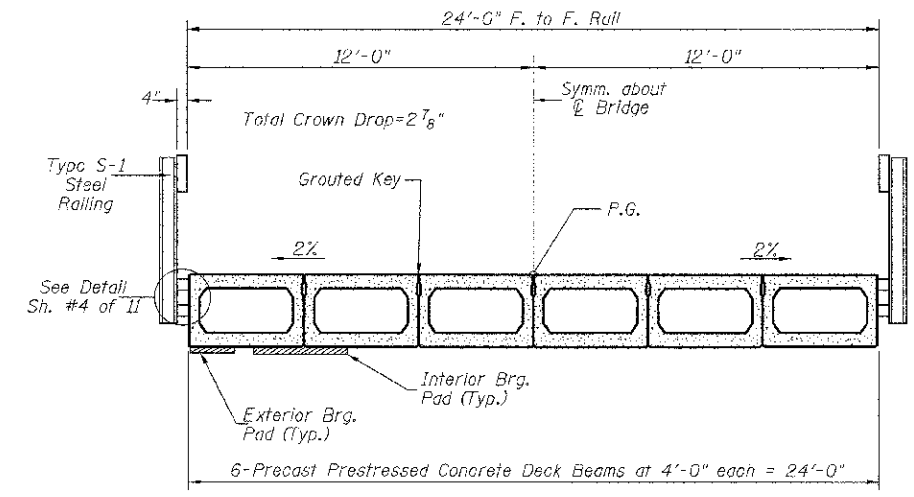

CROSS SECTION

BILL OF MATERIAL

ITEM	UNIT	QUANTITY
① Precast Prestressed Concrete Deck Beams (21" Depth)	SO FT	1,204

① See Special Provisions

NOTES

Prestressing steel shall be uncoated high strength, low relaxation 7-wire strand, Grade 270. The nominal diameter shall be 1/2" and the nominal cross-sectional area shall be 0.153 sq. in. The 1" rods in the transverse tie assembly shall be tightened to a snug fit and the threads set. Pockets on exterior faces of bridge shall be filled with grout after transverse tie assembly is in place.
 Reinforcement bars shall conform to ASTM A 706, Grade 60.
 Two 1/8" fabric adjusting shims of the dimensions of the exterior bearing pad shall be provided for each bearing pad location.
 A minimum 2 1/2" diameter lifting pin shall be used to engage the lifting loops during handling.
 Corrosion Inhibitor, per Article 1020.05(b)(12) and 1021.07 of the Standard Specifications, shall be used in the concrete for precast prestressed concrete deck beams.
 Compressive strength of prestressed concrete, f'c, shall be 6000 psi.
 Compressive strength of prestressed concrete at release, f'ci, shall be 5000 psi.

SUPERSTRUCTURE
BUREAU COUNTY
SECTION 07-03126-00-BR
T.R. 109 OVER LIME CREEK TRIBUTARY

SHEET NO. 2 11 SHEETS	ROUTE NO.	SECTION	COUNTY	TOTAL SHEETS	SHEET NO.
	TR 109	07-03126-00-BR	BUREAU	61	26
	S.N. 006-4088		CONTRACT NO. 87528		
FED. ROAD DIST. NO. 7		ILLINOIS	FED. AID PROJECT BROS-0011(087)		