

**GROUNDING DETAIL FOR THRESHOLD LIGHTS**  
(NOT TO SCALE)

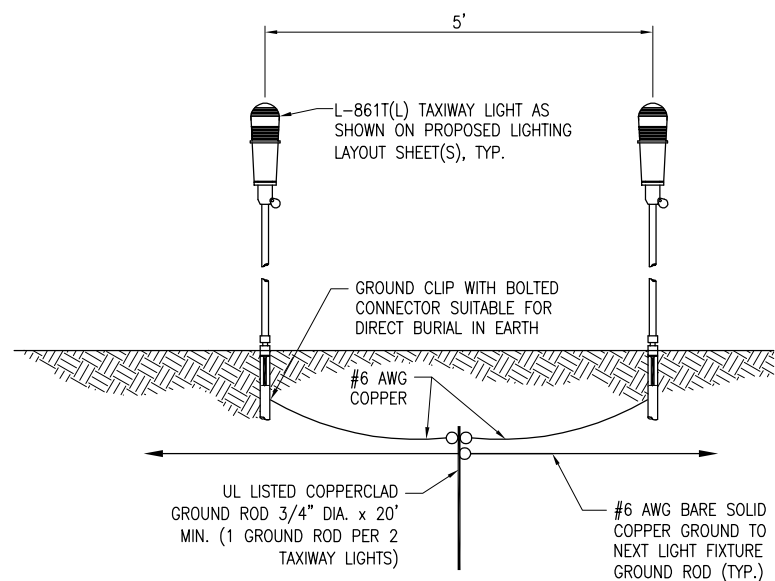

**GROUNDING DETAIL FOR ADJACENT TAXIWAY LIGHTS**  
(NOT TO SCALE)

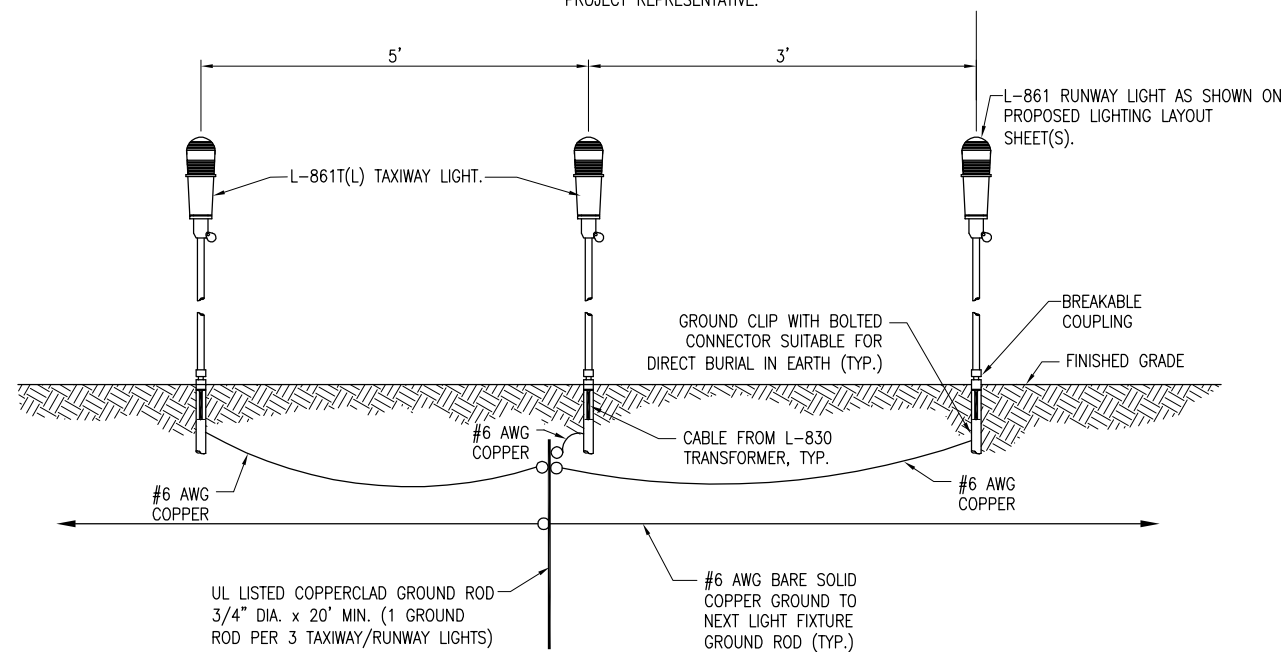

**GROUNDING DETAIL FOR ADJACENT RUNWAY AND TAXIWAY LIGHTS**  
(NOT TO SCALE)

**NOTES**

- GROUNDING FOR RUNWAY LIGHTS, TAXIWAY LIGHTS, AND LIGHTED TAXI GUIDANCE SIGNS SHALL BE AS DETAILED ON THE PLANS AND AS SPECIFIED HEREIN. PER FAA AC 150/5340-30G DESIGN AND INSTALLATION DETAILS FOR AIRPORT VISUAL AIDS, CHAPTER 12, PART 12.6; A GROUND MUST BE INSTALLED AT EACH LIGHT FIXTURE. THE PURPOSE OF THE LIGHT BASE GROUND IS TO PROVIDE A DEGREE OF PROTECTION FOR MAINTENANCE PERSONNEL FROM POSSIBLE CONTACT WITH AN ENERGIZED LIGHT BASE OR MOUNTING STAKE THAT MAY RESULT FROM A SHORTED POWER CABLE OR ISOLATION TRANSFORMER. A LIGHT BASE GROUND SHALL BE INSTALLED AT EACH TRANSFORMER BASE/LIGHT CAN ASSOCIATED WITH RUNWAY LIGHTS, TAXIWAY LIGHTS, AND LIGHTED TAXI GUIDANCE SIGNS. A LIGHT BASE GROUND SHALL ALSO BE INSTALLED AT EACH STAKE MOUNTED LIGHT FIXTURE. A LIGHT BASE GROUND SHALL BE INSTALLED AND CONNECTED TO THE METAL FRAME OF EACH TAXI GUIDANCE SIGN AS DETAILED ON THE PLANS AND IN ACCORDANCE WITH THE RESPECTIVE TAXI GUIDANCE SIGN MANUFACTURER RECOMMENDATIONS. THE LIGHT BASE GROUND SHALL BE A #6 AWG BARE COPPER CONDUCTOR BONDED TO THE GROUND LUG ON THE RESPECTIVE L-867 TRANSFORMER BASE/LIGHT CAN OR MOUNTING STAKE AND A 3/4-INCH DIAMETER BY 20-FOOT LONG (MINIMUM) UL LISTED COPPER CLAD GROUND ROD. (TWO 3/4-INCH DIAMETER BY 10-FOOT LONG, UL LISTED COPPERCLAD GROUND RODS COUPLED TOGETHER). 20-FOOT LONG GROUND RODS ARE REQUIRED DUE TO POOR RESISTANCE OF THE SOIL AT THE RESPECTIVE SITE. CONNECTIONS TO GROUND LUGS ON THE L-867 TRANSFORMER BASE/LIGHT CAN OR MOUNTING STAKE SHALL BE WITH A UL LISTED GROUNDING CONNECTOR SUITABLE FOR DIRECT BURIAL IN EARTH OR CONCRETE. CONNECTIONS TO GROUND RODS SHALL BE MADE WITH EXOTHERMIC WELD TYPE CONNECTORS, CADWELD BY ERICO PRODUCTS, INC., SOLON, OHIO, (PHONE: 800-248-9353), THERMOWELD BY CONTINENTAL INDUSTRIES, INC., TULSA, OKLAHOMA (PHONE: 918-663-1440), ULTRAWELD BY HARGER, GRAYSLAKE, ILLINOIS (PHONE: 800-842-7437), OR APPROVED EQUAL. EXOTHERMIC WELD CONNECTIONS SHALL BE INSTALLED IN CONFORMANCE WITH THE RESPECTIVE MANUFACTURER'S DIRECTIONS USING MOLDS AS REQUIRED FOR EACH RESPECTIVE APPLICATION. BOLTED CONNECTIONS WILL NOT BE PERMITTED AT GROUND RODS. TOP OF GROUND RODS SHALL BE BURIED 12 INCHES MINIMUM BELOW GRADE, UNLESS SPECIFIED OTHERWISE HEREIN, FOR RESPECTIVE APPLICATIONS
- FOR BASE MOUNTED LIGHT FIXTURES THE LIGHT FIXTURE MUST BE BONDED TO THE LIGHT BASE INTERNAL GROUND LUG VIA A #6 AWG STRANDED COPPER WIRE RATED FOR 600 VOLTS WITH GREEN XHHW OR USE INSULATION. THE GROUND WIRE LENGTH MUST BE SUFFICIENT TO ALLOW THE REMOVAL OF THE LIGHT FIXTURE FROM THE LIGHT BASE FOR ROUTINE MAINTENANCE. SEE THE LIGHT FIXTURE MANUFACTURER'S INSTRUCTIONS FOR PROPER METHODS OF ATTACHING A BONDING WIRE.
- FURNISH AND INSTALL A #6 AWG BARE SOLID COPPER GROUND AND BOND IT TO EACH GROUND ROD AT THE RESPECTIVE AIRFIELD LIGHT FIXTURES AND TAXI GUIDANCE SIGNS. THE #6 AWG GROUND SHALL BE DIRECT BURIAL IN TRENCH APPROXIMATELY 12 TO 18 INCHES BELOW GRADE. THE GROUND CONDUCTOR MAY BE INSTALLED ABOVE THE #8 FAA L-824, 5000-VOLT CABLE IN UNIT DUCT OR IN AN ADJACENT TRENCH. THE #6 AWG GROUND SHALL BE CONNECTED TO EACH RESPECTIVE GROUND ROD WITH AN EXOTHERMIC WELD CONNECTION. THE COMPLETED GROUND WIRE INSTALLED WILL PROVIDE A GROUND RING SYSTEM FOR THE RESPECTIVE AIRFIELD LIGHTING CIRCUIT. THE GROUND WIRE WILL NOT BE INSTALLED WITH THE HOMERUN CABLES FOR THE #6 AWG BARE SOLID COPPER GROUND WILL BE PAID FOR UNDER ITEM AR108756 1/C #6 GROUND PER LINEAR FOOT.
- FOR TAXIWAY LIGHTS THAT ARE SPACED WITH LESS THAN 10 FEET OF SEPARATION BETWEEN THEM PROVIDE ONE 3/4-INCH DIAMETER BY 20-FOOT LONG GROUND ROD PER TWO ADJACENT TAXIWAY LIGHTS.
- FOR RUNWAY THRESHOLD LIGHTS THAT ARE SPACED WITH 10 FEET OF SEPARATION BETWEEN THEM, PROVIDE ONE 3/4-INCH DIAMETER BY 20-FOOT LONG GROUND ROD PER TWO ADJACENT THRESHOLD LIGHTS. LOCATE GROUND ROD MIDWAY BETWEEN THE TWO THRESHOLD LIGHTS.
- STEEL USED TO MANUFACTURE GROUND RODS SHALL BE 100% DOMESTIC STEEL.
- FOR EACH GROUNDING ELECTRODE SYSTEM, THE CONTRACTOR SHALL TEST THE MADE ELECTRODE GROUND SYSTEM WITH AN INSTRUMENT SPECIFICALLY DESIGNED FOR TESTING GROUNDING SYSTEMS. TEST RESULTS SHALL BE RECORDED FOR EACH GROUNDING ELECTRODE SYSTEM. IF GROUND RESISTANCE EXCEEDS 25 OHMS, CONTACT THE PROJECT ENGINEER FOR FURTHER DIRECTION. COPIES OF THE GROUND SYSTEM TEST RESULTS SHALL BE FURNISHED TO THE RESIDENT ENGINEER/RESIDENT PROJECT REPRESENTATIVE.

REVISION	DATE	DESCRIPTION
12/11/12	12/11/12	UPDATED LT FIXTURE GROUNDING PER FAA AC 150/5340-30G & SOIL CONDITIONS

MARSHALL COUNTY AIRPORT  
LACON, ILLINOIS

IL PROJ.: C75-4223  
BLOCK GRANT PROJ.: 3-17-0059-B15

Hanson Proj. No. 10A0051	Filename R-546LE.DWG	Scale NONE	Date 12/14/12
LAYOUT	KNL	08/26/10	
DRAWN	MLH	09/01/10	
REVIEWED	KNL/CAH	03/30/11	

**HANSON**  
Professional Services Inc. 2013  
Hanson Professional Services Inc.  
1525 South Sixth Street  
Springfield, Illinois 62703-2986  
Ph: (217) 788-2450 Fax: (217) 788-2503  
www.hanson-inc.com  
Offices Nationwide

PAVE, LIGHT AND MARK  
805' EXTENSION

ELECTRICAL DETAILS  
SHEET 2

JAN 10, 2013 3:27 PM KINC00394  
E:\AIRPORTS\MARSHALL\10A0051\AIRPORT\ SHEETS\ R-546LE.DWG