

POINT	STA.	OFFSET	ELEV.
A	201+40.95	39.62' RT.	659.27
B	201+39.38	39.80' RT.	659.23
C	201+37.65	40.17' RT.	659.25
D	201+33.08	42.16' RT.	659.35
E	201+37.35	32.03' RT.	659.18
F	201+35.56	32.46' RT.	659.14
G	201+28.84	35.57' RT.	659.24

LAKEVIEW DRIVE AT COMMERCIAL DRIVEWAY
STA. 201+58



LAKEVIEW DRIVE

POINT	STA.	OFFSET	ELEV.
H	201+76.14	39.58' RT.	658.69
I	201+77.73	39.58' RT.	658.65
J	201+81.52	39.58' RT.	658.65
K	201+93.52	39.58' RT.	659.18
L	201+79.40	31.58' RT.	658.53
M	201+81.52	31.58' RT.	658.49
N	201+93.52	31.58' RT.	659.02

LAKEVIEW DRIVE AT COMMERCIAL DRIVEWAY
STA. 201+58

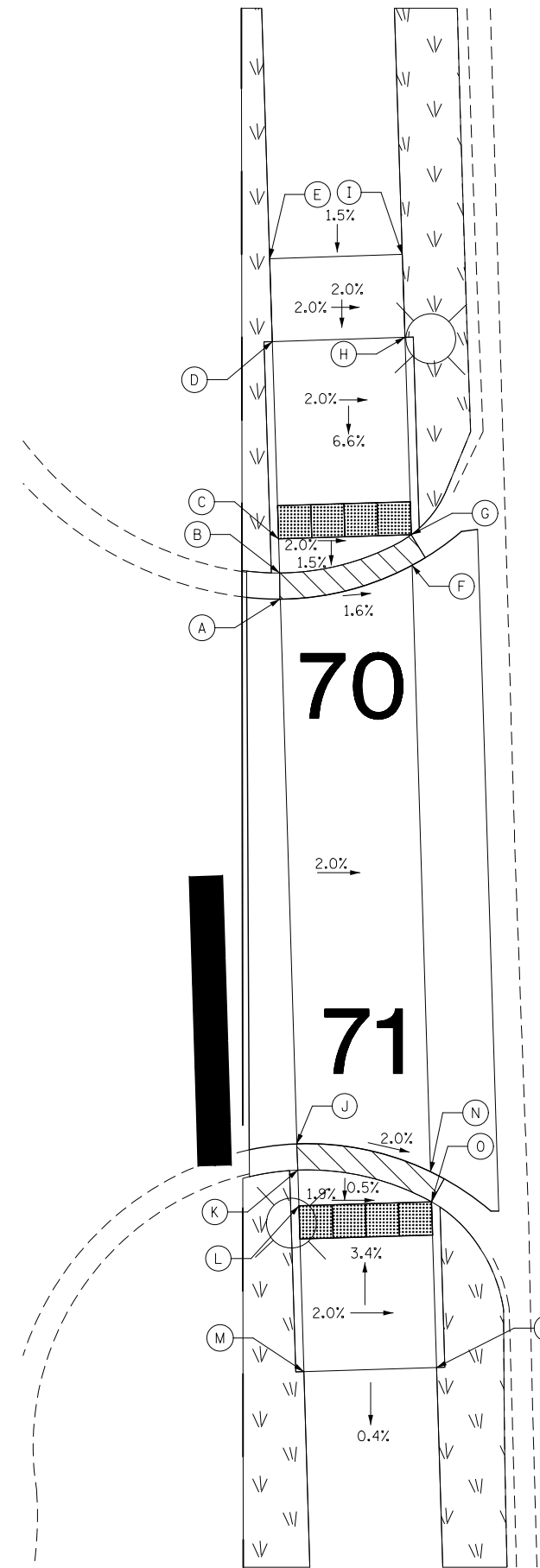

POINT	STA.	OFFSET	ELEV.
A	202+95.11	37.30' RT.	657.09
B	202+93.53	37.36' RT.	657.05
C	202+91.48	37.42' RT.	657.08
D	202+79.58	37.83' RT.	657.87
E	202+74.59	38.00' RT.	657.97
F	202+93.05	29.37' RT.	656.96
G	202+91.22	29.43' RT.	656.92
H	202+79.31	29.83' RT.	657.71
I	202+74.31	30.00' RT.	657.81

LAKEVIEW DRIVE AT COMMERCIAL DRIVEWAY
STA. 203+12

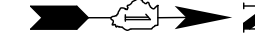

LAKEVIEW DRIVE

POINT	STA.	OFFSET	ELEV.
J	203+27.96	36.23' RT.	656.68
K	203+29.54	36.18' RT.	656.64
L	203+31.69	36.11' RT.	656.63
M	203+41.69	35.78' RT.	656.98
N	203+29.62	28.17' RT.	656.52
O	203+31.43	28.11' RT.	656.48
P	203+41.42	27.79' RT.	656.82

LAKEVIEW DRIVE AT COMMERCIAL DRIVEWAY
STA. 203+12

FILE NAME = D:\60X10-shr-ADA25.dgn

KNIGHT Engineers & Architects	USER NAME = MMaestra	DESIGNED PAW	REVISED -
	PLOT SCALE = 1:10	DRAWN PAW	REVISED -
	PLOT DATE = 8/23/2017	CHECKED PJO	REVISED -
		DATE 08/25/17	REVISED -

STATE OF ILLINOIS
DEPARTMENT OF TRANSPORTATION

ADA RAMP DETAILS
WEBER ROAD & LAKEVIEW DRIVE

SCALE: 1" = 5' SHEET NO. 25 OF 28 SHEETS STA. TO STA.

F.A.I./P RTE.	SECTION	COUNTY	TOTAL SHEETS	SHEET NO.
*	(99-1HB-1) R-1	WILL	1508	501
				CONTRACT NO. 60X10
* FAI 55, FAP 856 [ILLINOIS] FED. AID PROJECT				

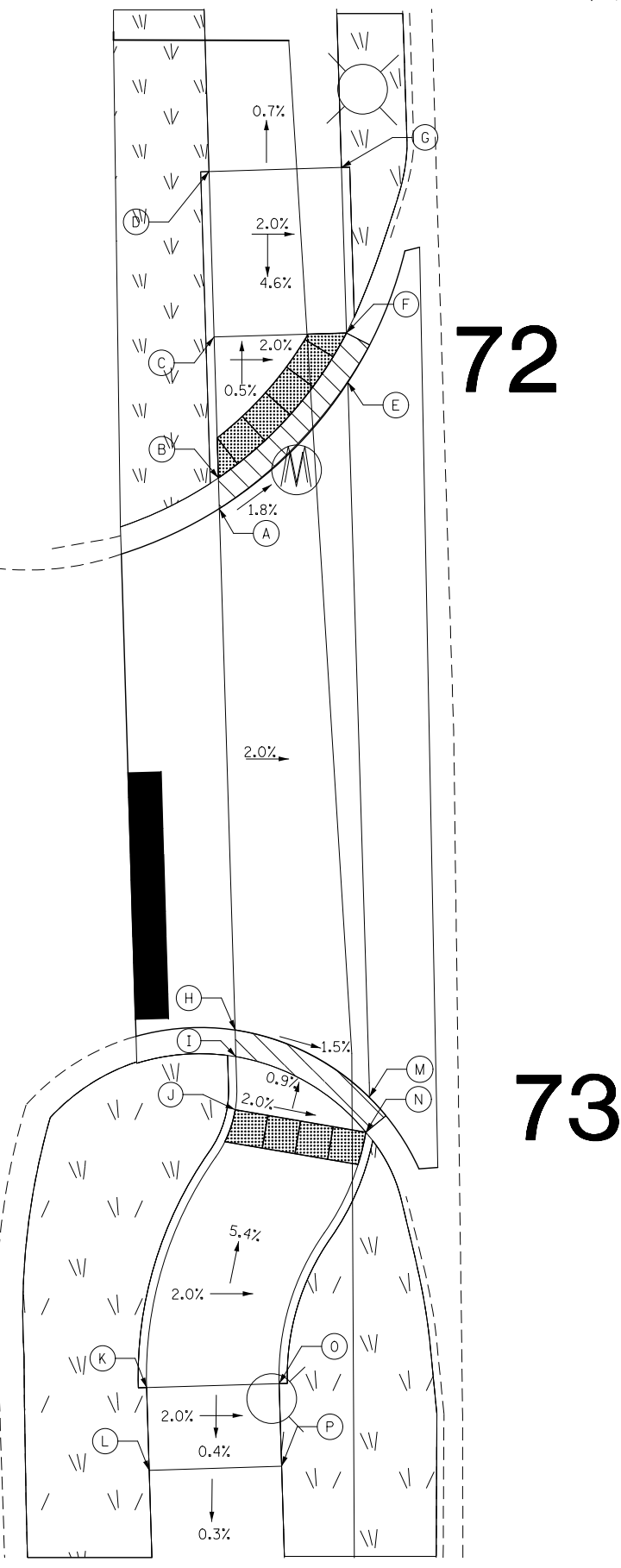
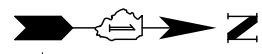

POINT	STA.	OFFSET	ELEV.
A	204+33.12	32.79' RT.	656.55
B	204+31.27	32.85' RT.	656.51
C	204+22.76	33.13' RT.	656.47
D	204+12.76	33.46' RT.	656.93
E	204+25.47	25.04' RT.	656.35
F	204+22.49	25.14' RT.	656.31
G	204+12.50	25.46' RT.	656.77

LAKEVIEW DRIVE AT COMMERCIAL DRIVEWAY
STA. 204+50.42

POINT	STA.	OFFSET	ELEV.
H	204+64.60	31.77' RT.	656.71
I	204+66.21	31.71' RT.	656.67
J	204+69.43	31.75' RT.	656.69
K	204+86.21	37.06' RT.	657.61
L	204+91.21	36.90' RT.	657.59
M	204+68.64	23.65' RT.	656.57
N	204+70.76	23.86' RT.	656.53
O	204+85.95	29.07' RT.	657.45
P	204+90.95	28.90' RT.	657.43

LAKEVIEW DRIVE AT COMMERCIAL DRIVEWAY
STA. 204+50.42

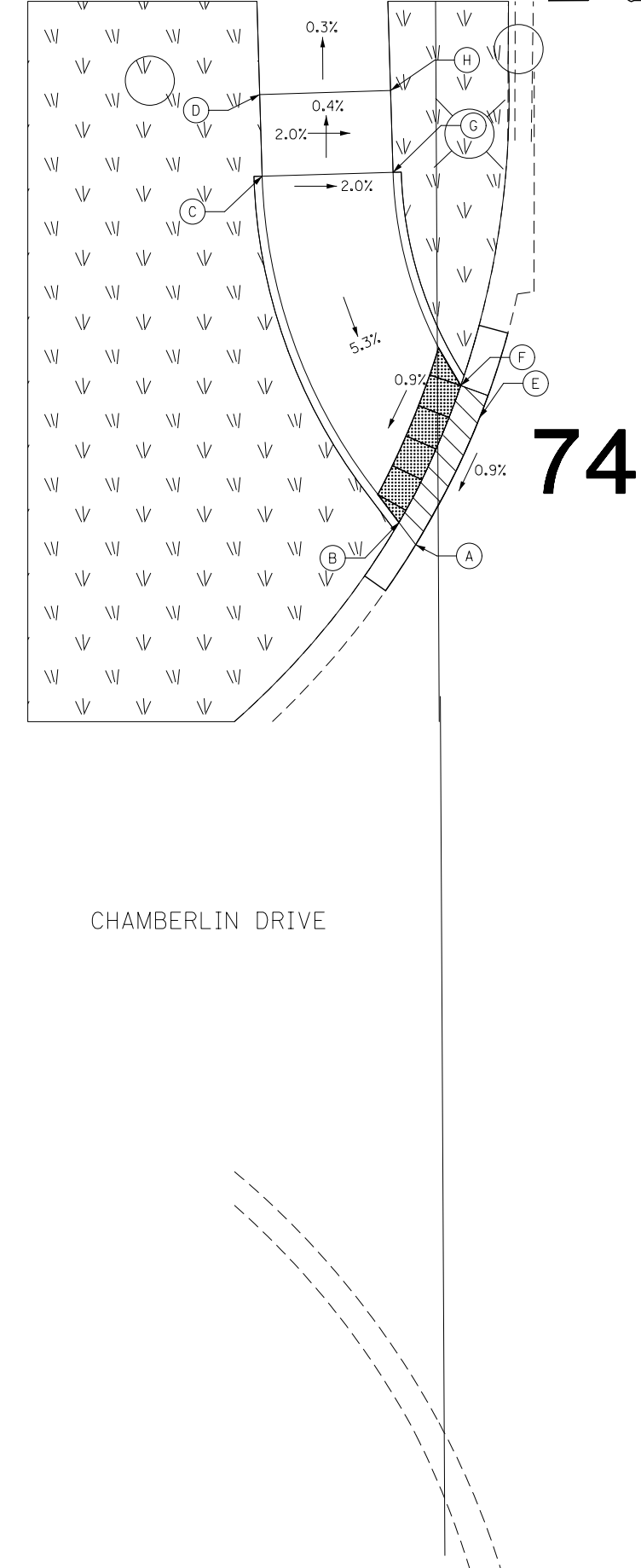

POINT	STA.	OFFSET	ELEV.
A	205+81.14	24.91' RT.	656.51
B	205+80.33	26.27' RT.	656.47
C	205+59.21	34.68' RT.	657.58
D	205+55.20	34.81' RT.	657.56
E	205+72.96	20.98' RT.	656.59
F	205+71.96	22.52' RT.	656.55
G	205+58.94	26.68' RT.	657.42
H	205+54.94	26.81' RT.	657.40

LAKEVIEW DRIVE AT COMMERCIAL DRIVEWAY
STA. 206+26

FILE NAME = D:\60X10-shr-AD026.dgn

KNIGHT Engineers & Architects	USER NAME = MMaestra	DESIGNED PAW	REVISED -
	PLOT SCALE = 1:10	DRAWN PAW	REVISED -
	PLOT DATE = 8/23/2017	CHECKED PJO	REVISED -
		DATE 08/25/17	REVISED -

STATE OF ILLINOIS
DEPARTMENT OF TRANSPORTATION

ADA RAMP DETAILS	
WEBER ROAD & LAKEVIEW DRIVE	
SCALE: 1" = 5'	SHEET NO. 26 OF 28 SHEETS
STA.	TO STA.

F.A.I./P RTE.	SECTION	COUNTY	TOTAL SHEETS	SHEET NO.
*	(99-1HB-1) R-1	WILL	1508	502
CONTRACT NO. 60X10				
* FAI 55, FAP 856 ILLINOIS FED. AID PROJECT				

POINT	STA.	OFFSET	ELEV.
A	304+28.96	37.33' LT.	653.51
B	304+27.13	37.44' LT.	653.47
C	304+20.14	37.85' LT.	653.71
D	304+31.26	43.20' LT.	653.63
E	304+29.71	43.29' LT.	653.59
F	304+27.47	43.43' LT.	653.59
G	304+20.47	43.84' LT.	653.83

WINDHAM PKWY AT COMMERCIAL DRIVEWAY
STA. 304+42.97

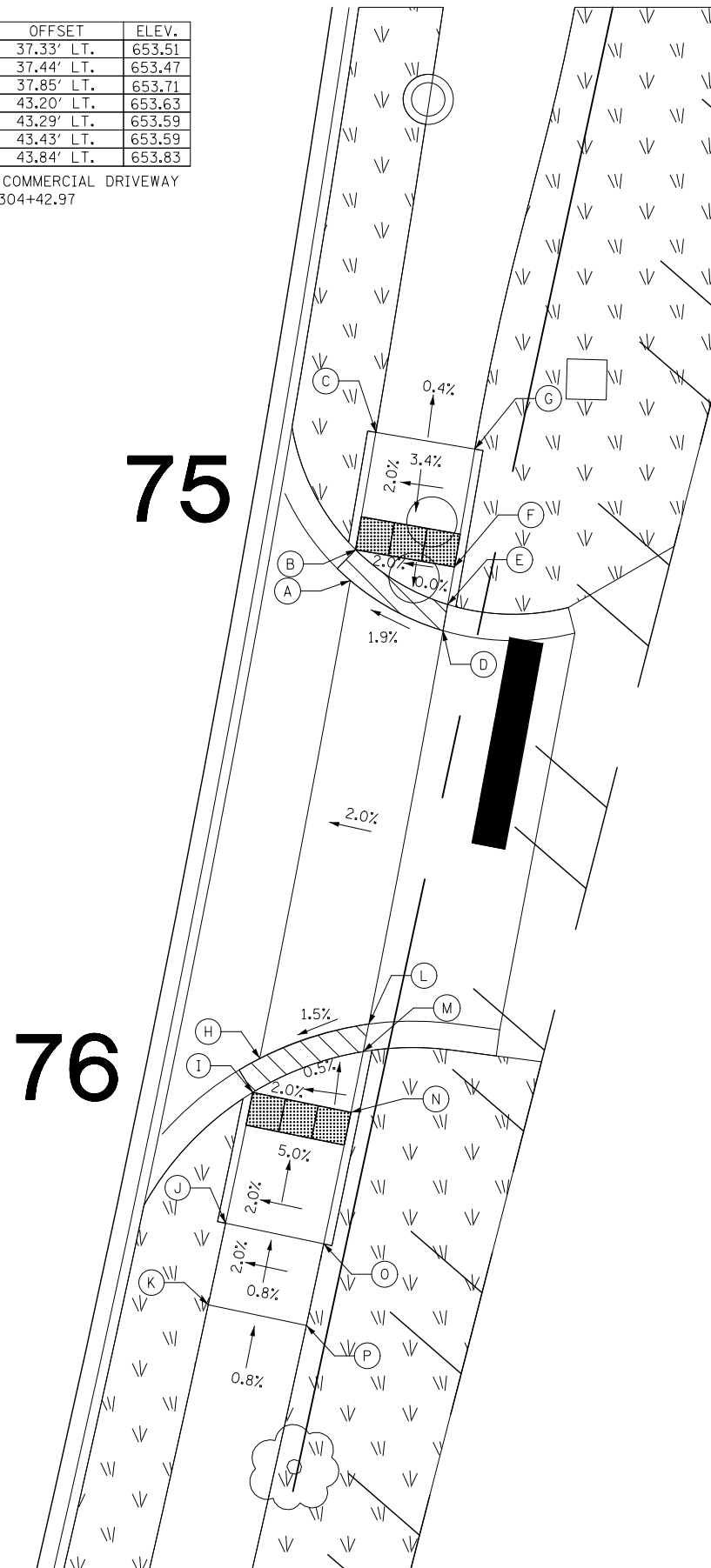
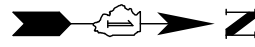

POINT	STA.	OFFSET	ELEV.
H	304+57.51	35.44' LT.	653.62
I	304+59.55	35.30' LT.	653.58
J	304+67.40	34.73' LT.	653.98
K	304+71.40	34.43' LT.	654.02
L	304+54.69	41.66' LT.	653.72
M	304+56.33	41.54' LT.	653.68
N	304+59.97	41.28' LT.	653.70
O	304+67.83	40.71' LT.	654.10
P	304+71.81	40.41' LT.	654.14

WINDHAM PKWY AT COMMERCIAL DRIVEWAY
STA. 304+42.97

POINT	STA.	OFFSET	ELEV.
A	397+77.78	35.38' LT.	650.99
B	397+76.11	35.38' LT.	650.95
C	397+68.11	35.38' LT.	650.88
D	397+78.90	40.38' LT.	651.09
E	397+77.31	40.38' LT.	651.05
F	397+76.11	40.38' LT.	651.05
G	397+68.11	40.38' LT.	650.98

CARLOW DRIVE AT COMMERCIAL DRIVEWAY
STA. 397+92

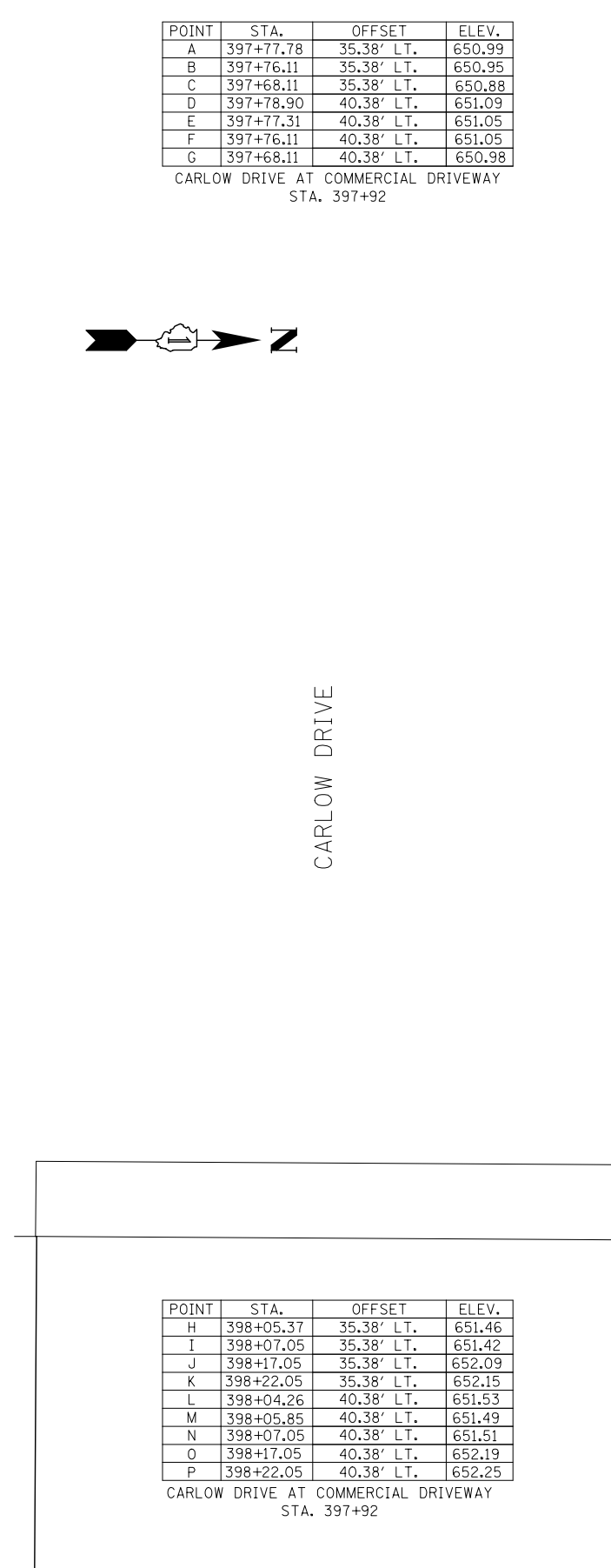

POINT	STA.	OFFSET	ELEV.
H	398+05.37	35.38' LT.	651.46
I	398+07.05	35.38' LT.	651.42
J	398+17.05	35.38' LT.	652.09
K	398+22.05	35.38' LT.	652.15
L	398+04.26	40.38' LT.	651.53
M	398+05.85	40.38' LT.	651.49
N	398+07.05	40.38' LT.	651.51
O	398+17.05	40.38' LT.	652.19
P	398+22.05	40.38' LT.	652.25

CARLOW DRIVE AT COMMERCIAL DRIVEWAY
STA. 397+92

FILE NAME = D:\60X10-shr-ADA27.dgn

KNIGHT

Engineers & Architects

USER NAME = MMaestra	DESIGNED PAW	REVISED -
PLOT SCALE = 1:10	DRAWN PAW	REVISED -
PLOT DATE = 8/23/2017	CHECKED PJO	REVISED -
	DATE 08/25/17	REVISED -

STATE OF ILLINOIS
DEPARTMENT OF TRANSPORTATION

ADA RAMP DETAILS
WEBER ROAD & WINDHAM PKWY & CARLOW DRIVE

SCALE: 1" = 5' SHEET NO. 27 OF 28 SHEETS STA. TO STA.

F.A.I./P RTE.	SECTION	COUNTY	TOTAL SHEETS	SHEET NO.
*	(99-1HB-1) R-1	WILL	1508	503
CONTRACT NO. 60X10				
* FAI 55, FAP 856 [ILLINOIS] FED. AID PROJECT				

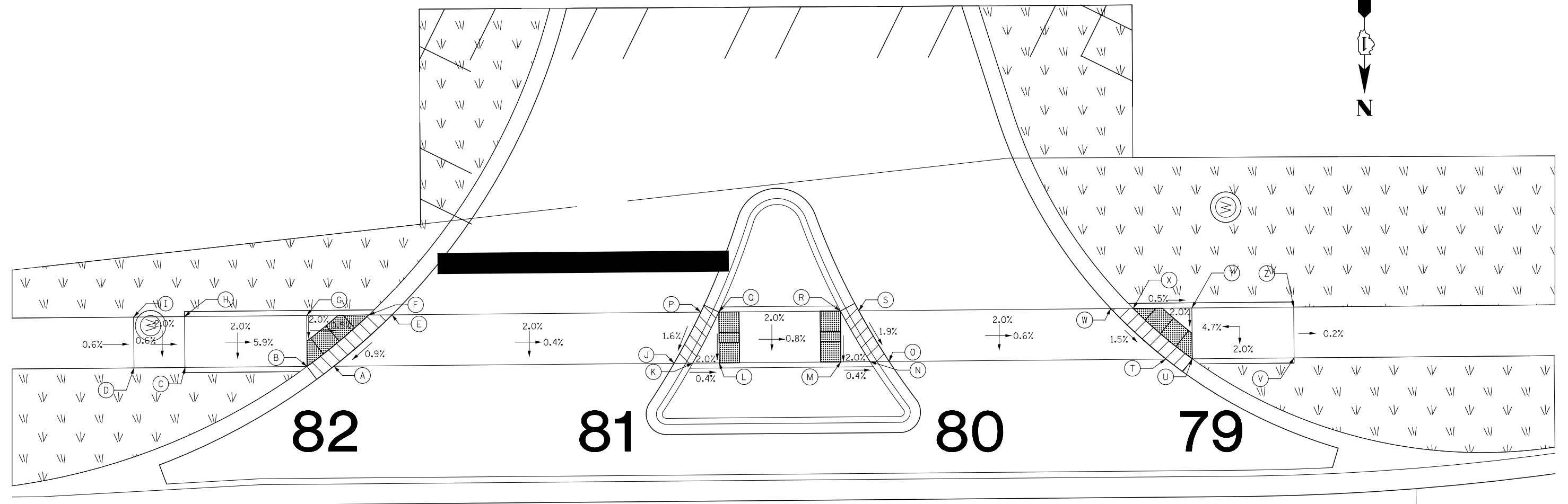
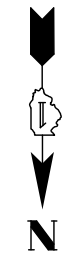

REMINGTON BLVD

POINT	STA.	OFFSET	ELEV.
A	502+77.09	33.58' RT.	654.10
B	502+79.73	33.58' RT.	654.06
C	502+91.73	33.58' RT.	654.77
D	502+96.73	33.58' RT.	654.80
E	502+71.35	38.58' RT.	654.17
F	502+73.64	38.58' RT.	654.13
G	502+79.73	38.58' RT.	654.16
H	502+91.73	38.58' RT.	654.87
I	502+96.73	38.58' RT.	654.90

POINT	STA.	OFFSET	ELEV.
J	502+43.69	33.58' RT.	653.93
K	502+41.86	33.58' RT.	653.89
L	502+39.26	33.58' RT.	653.88
M	502+27.30	33.58' RT.	653.78
N	502+24.45	33.58' RT.	653.77
O	502+22.57	33.58' RT.	653.81
P	502+41.02	38.58' RT.	654.02
Q	502+39.26	38.58' RT.	653.98
R	502+27.30	38.58' RT.	653.88
S	502+25.52	38.55' RT.	653.92

POINT	STA.	OFFSET	ELEV.
T	501+95.40	33.58' RT.	653.65
U	501+92.81	33.58' RT.	653.61
V	501+82.81	33.58' RT.	654.08
W	502+00.76	38.47' RT.	653.76
X	501+98.57	38.58' RT.	653.72
Y	501+92.81	38.58' RT.	653.71
Z	501+82.81	38.58' RT.	654.18

REMINGTON BLVD AT COMMERCIAL DRIVEWAY
STA. 502+33

FILE NAME = D:\60X10-eh-t-ADA28.dgn



USER NAME = MMaestra	DESIGNED PAW	REVISED -
	DRAWN PAW	REVISED -
PLOT SCALE = 1:10	CHECKED PJO	REVISED -
PLOT DATE = 8/23/2017	DATE 08/25/17	REVISED -

STATE OF ILLINOIS
DEPARTMENT OF TRANSPORTATION

ADA RAMP DETAILS		WEBER ROAD & REMINGTON BLVD	
SCALE: 1" = 5'	SHEET NO. 28 OF 28 SHEETS	STA.	TO STA.

F.A.I./P RTE.	SECTION	COUNTY	TOTAL SHEETS	SHEET NO.
*	(99-1HB-1) R-1	WILL	1508	504
CONTRACT NO. 60X10				
* FAI 55, FAP 856 ILLINOIS FED. AID PROJECT				

WEBER ROAD SOUTHBOUND														WEBER ROAD NORTHBOUND																						
RIGHT TURN LANE			LANE 3			LANE 2/3			LANE 1/2			PGL		LEFT TURN LANE(S)			STATION	LEFT TURN LANE(S)			PGL		LANE 1/2			LANE 2/3			LANE 3			RIGHT TURN LANE				
ELEV.	SLOPE	OFFSET	ELEV.	SLOPE	OFFSET	ELEV.	SLOPE	OFFSET	ELEV.	SLOPE	OFFSET	ELEV.	OFFSET	ELEV.	SLOPE	OFFSET		ELEV.	SLOPE	OFFSET	ELEV.	OFFSET	ELEV.	SLOPE	OFFSET	ELEV.	SLOPE	OFFSET	ELEV.	SLOPE	OFFSET	ELEV.	SLOPE	OFFSET	ELEV.	SLOPE
NORMANTOWN ROAD/DDI (SEE INTERSECTION DETAIL SHEETS)														811+00	NORMANTOWN ROAD/DDI (SEE INTERSECTION DETAIL SHEETS)																					
														811+25																						
														811+50																						
														811+75																						
														812+00																						
														812+25																						
														812+50																						
														812+75																						
														813+00																						
														813+25																						
														813+50																						
														813+75																						
														814+00																						
														814+25																						
														814+50																						
														814+75																						
														815+00																						
														815+25																						
														815+50																						
														815+75																						
														816+00																						
														816+25																						
														816+50																						
														816+75																						
														817+00																						
817+25																																				
817+50																																				
817+75																																				
818+00																																				
818+25																																				
818+50																																				
818+75																																				
819+00																																				
819+25																																				
819+50																																				
819+75																																				
820+00																																				
820+25																																				
820+50																																				
820+75																																				
821+00																																				
821+25																																				
821+50																																				
821+75																																				
822+00																																				
822+25																																				
822+50																																				
822+75																																				
823+00																																				
823+25																																				
823+50																																				
823+75																																				
824+00																																				
824+25																																				
824+50																																				
824+75																																				
825+00																																				
825+25																																				
825+50																																				
825+75																																				
826+00																																				
826+25																																				
826+50																																				
826+75																																				
827+00																																				
827+25																																				
827+50																																				
827+75																																				
828+00																																				
828+25																																				

FILE NAME = D:\60X10-shr-elev\02.dgn

WEBER ROAD SOUTHBOUND															WEBER ROAD NORTHBOUND																											
RIGHT TURN LANE			LANE 3			LANE 2/3			LANE 1/2			PGL		LEFT TURN LANE(S)						STATION	LEFT TURN LANE(S)						PGL		LANE 1/2			LANE 2/3			LANE 3			RIGHT TURN LANE				
ELEV.	SLOPE	OFFSET	ELEV.	SLOPE	OFFSET	ELEV.	SLOPE	OFFSET	ELEV.	SLOPE	OFFSET	ELEV.	OFFSET	ELEV.	SLOPE	OFFSET	ELEV.	SLOPE	OFFSET		ELEV.	SLOPE	OFFSET	ELEV.	OFFSET	ELEV.	SLOPE	OFFSET	ELEV.	SLOPE	OFFSET	ELEV.	SLOPE	OFFSET	ELEV.	SLOPE	OFFSET	ELEV.	SLOPE	OFFSET	ELEV.	SLOPE
						656.67	-2.00	-24.00	656.91	-2.00	-12.00	657.15	0.00										657.15	0.00	656.91	-2.00	12.00	656.67	-2.00	24.00	656.58	-2.50	27.57									
						656.77	-2.00	-24.00	657.01	-2.00	-12.00	657.25	0.00										657.25	0.00	657.01	-2.00	12.00	656.77	-2.00	24.00	656.69	-2.50	27.11									
						656.87	-2.00	-24.00	657.11	-2.00	-12.00	657.35	0.00										657.35	0.00	657.11	-2.00	12.00	656.87	-2.00	24.00	656.81	-2.50	26.41									
						656.97	-2.00	-24.00	657.21	-2.00	-12.00	657.45	0.00										657.45	0.00	657.21	-2.00	12.00	656.97	-2.00	24.00	656.93	-2.50	25.56									

FILE NAME = D:\60X10-shr-elev\05.dgn

	USER NAME = mmaestra	DESIGNED RAM	REVISED -
		DRAWN RAM	REVISED -
	PLOT SCALE = 1:2	CHECKED PJO	REVISED -
	PLOT DATE = 5/13/2017	DATE 05/12/17	REVISED -

STATE OF ILLINOIS
DEPARTMENT OF TRANSPORTATION

PAVEMENT ELEVATIONS - WEBER ROAD			
SCALE: NONE	SHEET NO. 5 OF 5 SHEETS	STA.	TO STA.

F.A.I./P RTE.	SECTION	COUNTY	TOTAL SHEETS	SHEET NO.
*	(99-1HB-1) R-1	WILL	1508	509
* FAI 55, FAP 856 ILLINOIS FED. AID PROJECT			CONTRACT NO. 60X10	

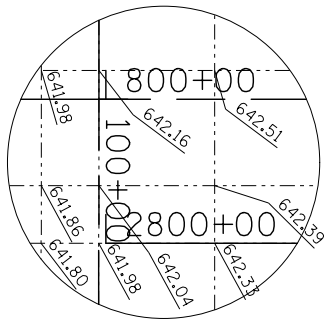

LEGEND:

- PAVEMENT SEPARATION JOINT
SEE IDOT DISTRICT ONE STANDARD BD52
- TRANSVERSE EXPANSION JOINT
SEE IDOT STANDARD 420001
- DEAD END JOINT
SEE IDOT DISTRICT ONE STANDARD BD53
- LENGTH IN FEET OF PANEL BETWEEN TRANSVERSE JOINTS IF DIFFERENT THAN 15.0'

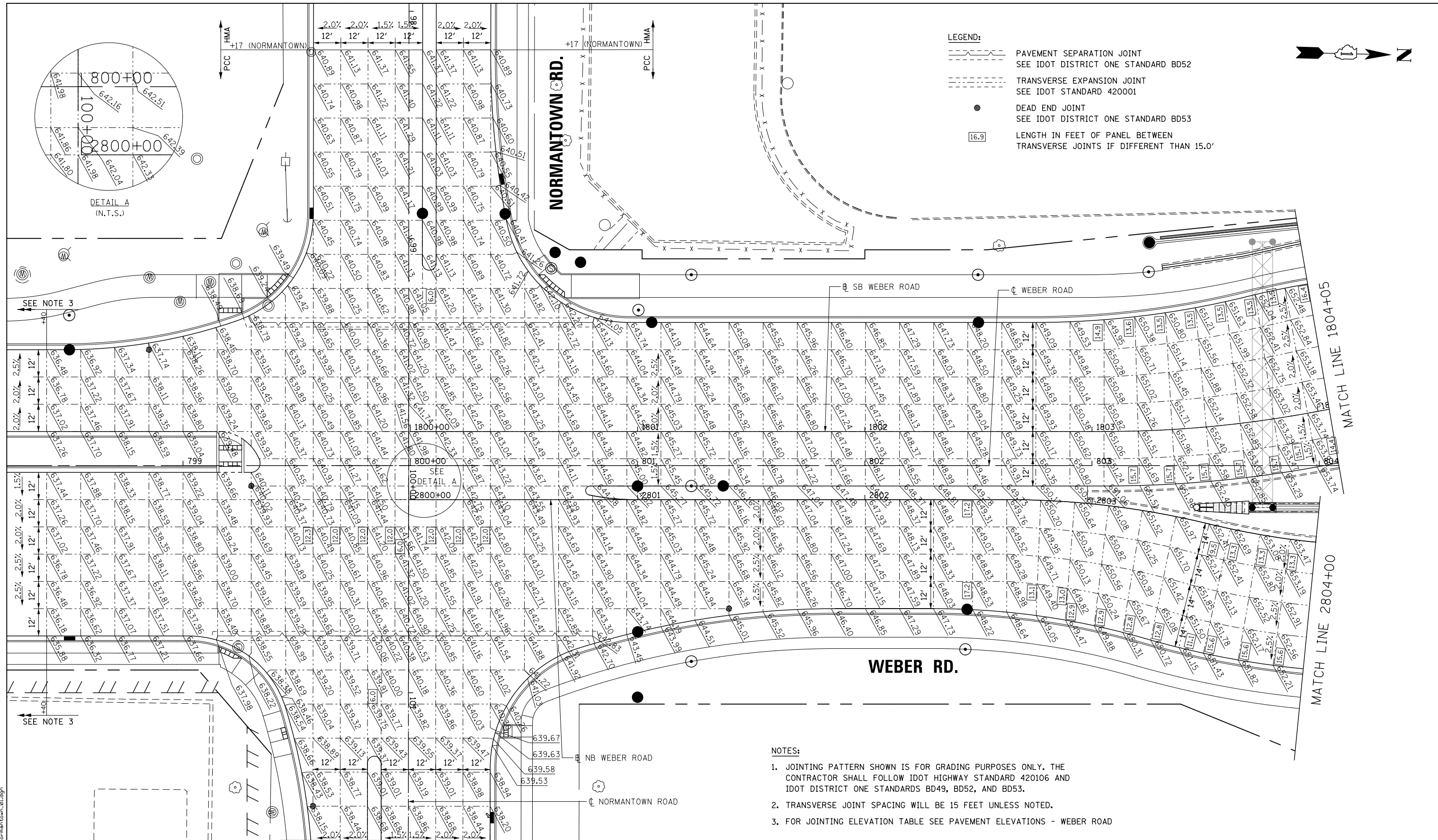
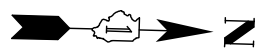

- NOTES:**
1. JOINTING PATTERN SHOWN IS FOR GRADING PURPOSES ONLY. THE CONTRACTOR SHALL FOLLOW IDOT HIGHWAY STANDARD 420106 AND IDOT DISTRICT ONE STANDARDS BD49, BD52, AND BD53.
 2. TRANSVERSE JOINT SPACING WILL BE 15 FEET UNLESS NOTED.
 3. FOR JOINTING ELEVATION TABLE SEE PAVEMENT ELEVATIONS - WEBER ROAD
 4. FOR PROPOSED NORMANTOWN ROAD PAVEMENT AND PROFILE INFORMATION SEE: PLAN / PROFILE - NORMANTOWN ROAD SHEETS.



FILE NAME = E02410-ent-pvt-joint01-Normantown_01.dgn



USER NAME = mmaestra	DESIGNED WVN	REVISED -
PLOT SCALE = 1:40	DRAWN WVN	REVISED -
PLOT DATE = 5/13/2017	CHECKED PJO	REVISED -
	DATE 05/12/17	REVISED -

**STATE OF ILLINOIS
DEPARTMENT OF TRANSPORTATION**

INTERSECTION DETAIL		
WEBER ROAD & NORMANTOWN ROAD		
SCALE: AS SHOWN	SHEET NO. 1 OF 11 SHEETS	STA. 798+40 TO STA. 804+08

F.A.I./P RTE.	SECTION	COUNTY	TOTAL SHEETS	SHEET NO.
*	(99-1HB-1) R-1	WILL	1508	510
CONTRACT NO. 60X10				
* FAI 55, FAP 856 [ILLINOIS] FED. AID PROJECT				

- LEGEND:**
- PAVEMENT SEPARATION JOINT
SEE IDOT DISTRICT ONE STANDARD BD52
 - TRANSVERSE EXPANSION JOINT
SEE IDOT STANDARD 420001
 - DEAD END JOINT
SEE IDOT DISTRICT ONE STANDARD BD53
 - LENGTH IN FEET OF PANEL BETWEEN
TRANSVERSE JOINTS IF DIFFERENT THAN 15.0'

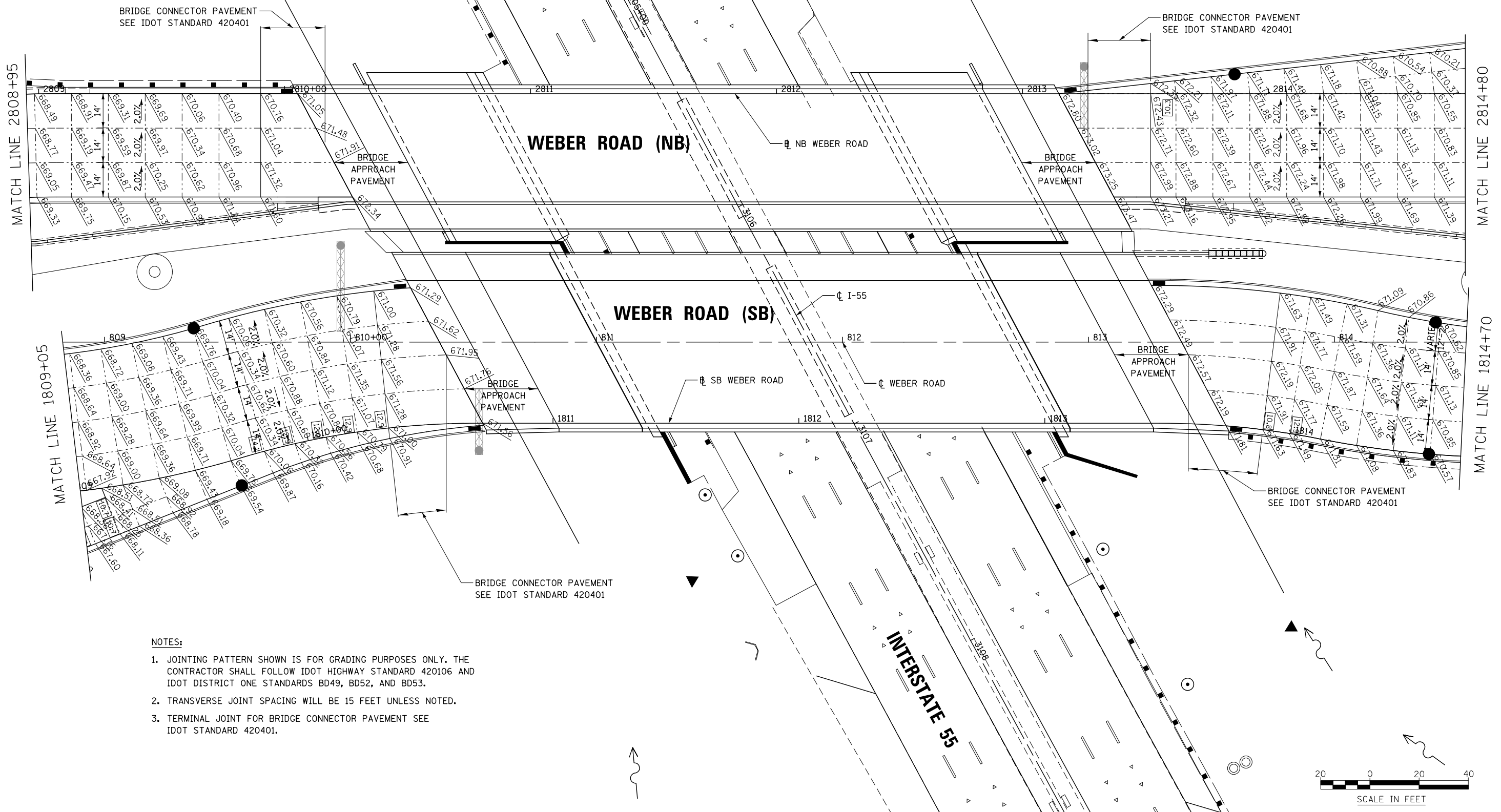
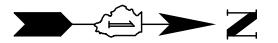

- NOTES:**
1. JOINTING PATTERN SHOWN IS FOR GRADING PURPOSES ONLY. THE CONTRACTOR SHALL FOLLOW IDOT HIGHWAY STANDARD 420106 AND IDOT DISTRICT ONE STANDARDS BD49, BD52, AND BD53.
 2. TRANSVERSE JOINT SPACING WILL BE 15 FEET UNLESS NOTED.
 3. TERMINAL JOINT FOR BRIDGE CONNECTOR PAVEMENT SEE IDOT STANDARD 420401.

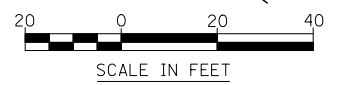

FILE NAME = 60210-sht-pvt-join04-WeberOver-55.dgn



USER NAME = dbarnes	DESIGNED WVN	REVISED -
DRAWN WVN	REVISOR -	
PLOT SCALE = 1:40	CHECKED PJO	REVISED -
PLOT DATE = 9/21/2017	DATE 11/15/17	REVISED -

**STATE OF ILLINOIS
DEPARTMENT OF TRANSPORTATION**

**INTERSECTION DETAIL
WEBER ROAD OVER INTERSTATE 55**

SCALE: AS SHOWN SHEET NO. 4 OF 11 SHEETS STA. 808+83 TO STA. 814+54

F.A.I./P RTE.	SECTION	COUNTY	TOTAL SHEETS	SHEET NO.
*	(99-1HB-1) R-1	WILL	1508	513
CONTRACT NO. 60X10				
* FAI 55, FAP 856 [ILLINOIS] FED. AID PROJECT				



NOTES:

1. JOINTING PATTERN SHOWN IS FOR GRADING PURPOSES ONLY. THE CONTRACTOR SHALL FOLLOW IDOT HIGHWAY STANDARD 420106 AND IDOT DISTRICT ONE STANDARDS BD49, BD52, AND BD53.
2. TRANSVERSE JOINT SPACING WILL BE 15 FEET UNLESS NOTED.
3. FOR PROPOSED PAVEMENT AND PROFILE INFORMATION SEE: PLAN / PROFILE - RAMP A SHEETS.
4. FOR PROPOSED PAVEMENT AND PROFILE INFORMATION SEE: PLAN / PROFILE - RAMP D SHEETS.

TRANSVERSE EXPANSION JOINT
SEE IDOT STANDARD 420001

WEBER ROAD

LEGEND:

- PAVEMENT SEPARATION JOINT
SEE IDOT DISTRICT ONE STANDARD BD52
- TRANSVERSE EXPANSION JOINT
SEE IDOT STANDARD 420001
- DEAD END JOINT
SEE IDOT DISTRICT ONE STANDARD BD53
- LENGTH IN FEET OF PANEL BETWEEN
TRANSVERSE JOINTS IF DIFFERENT THAN 15.0'

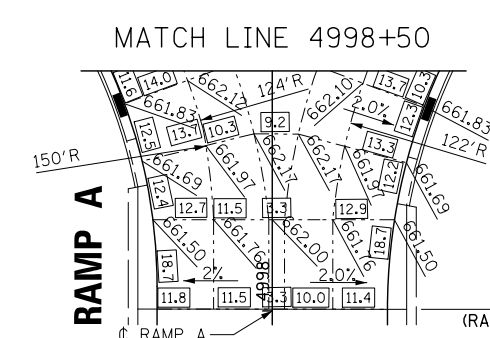
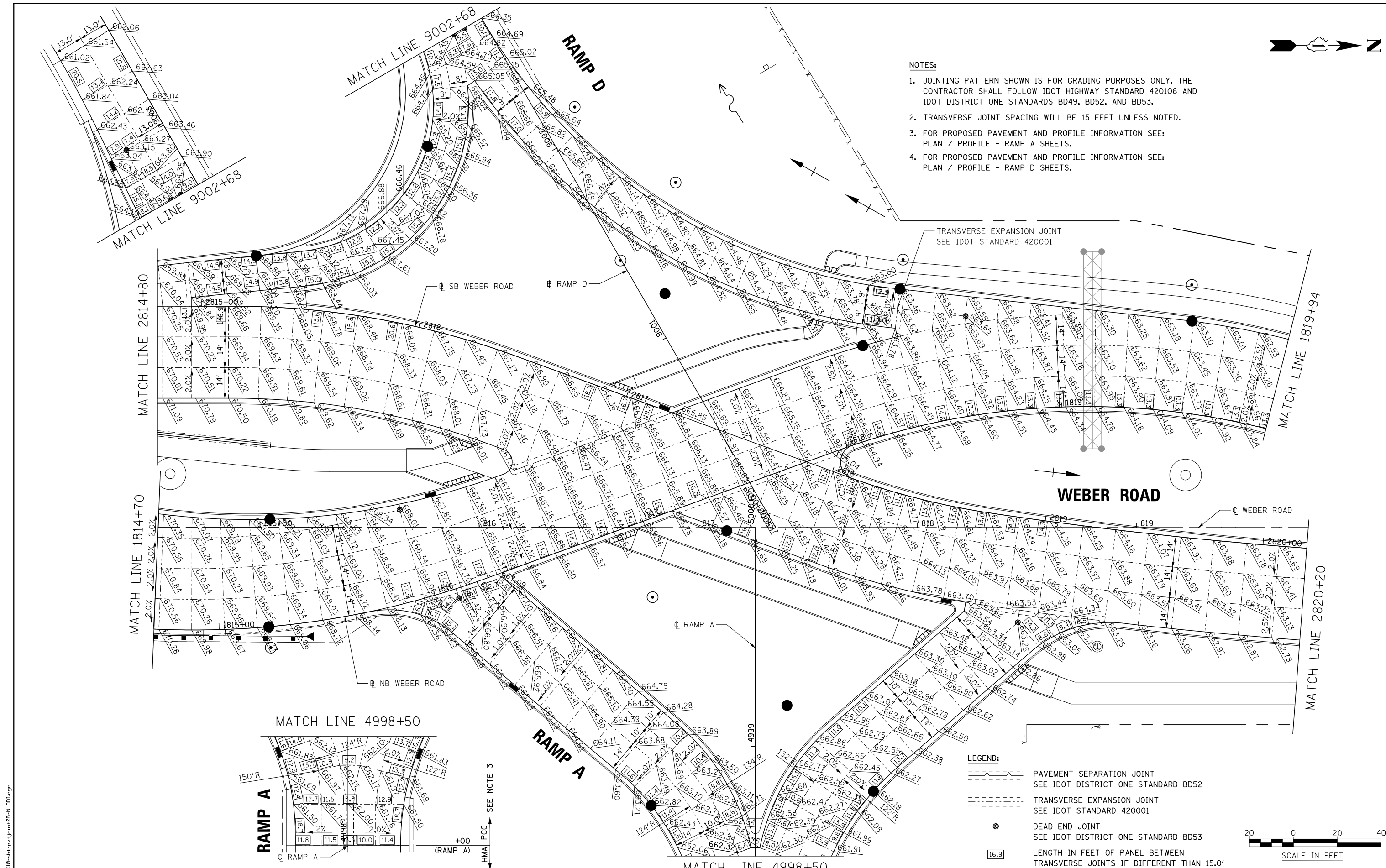
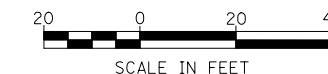

FILE NAME = 62010-ent-pvt-joint05-N.D01.dgn



USER NAME = dbarnes	DESIGNED WVN	REVISED -
PLOT SCALE = 1:40	DRAWN WVN	REVISED -
PLOT DATE = 10/27/2017	CHECKED PJO	REVISED -
	DATE 11/15/17	REVISED -

**STATE OF ILLINOIS
DEPARTMENT OF TRANSPORTATION**

**INTERSECTION DETAIL
WEBER ROAD AND RAMPS A & D**

SCALE: AS SHOWN SHEET NO. 5 OF 11 SHEETS STA. 814+54 TO STA. 819+75

F.A.I./P RTE.	SECTION	COUNTY	TOTAL SHEETS	SHEET NO.
*	(99-1HB-1) R-1	WILL	1508	514
CONTRACT NO. 60X10			* FAI 55, FAP 856 [ILLINOIS] FED. AID PROJECT	

- LEGEND:**
- PAVEMENT SEPARATION JOINT
SEE IDOT DISTRICT ONE STANDARD BD52
 - TRANSVERSE EXPANSION JOINT
SEE IDOT STANDARD 420001
 - DEAD END JOINT
SEE IDOT DISTRICT ONE STANDARD BD53
 - LENGTH IN FEET OF PANEL BETWEEN
TRANSVERSE JOINTS IF DIFFERENT THAN 15.0'

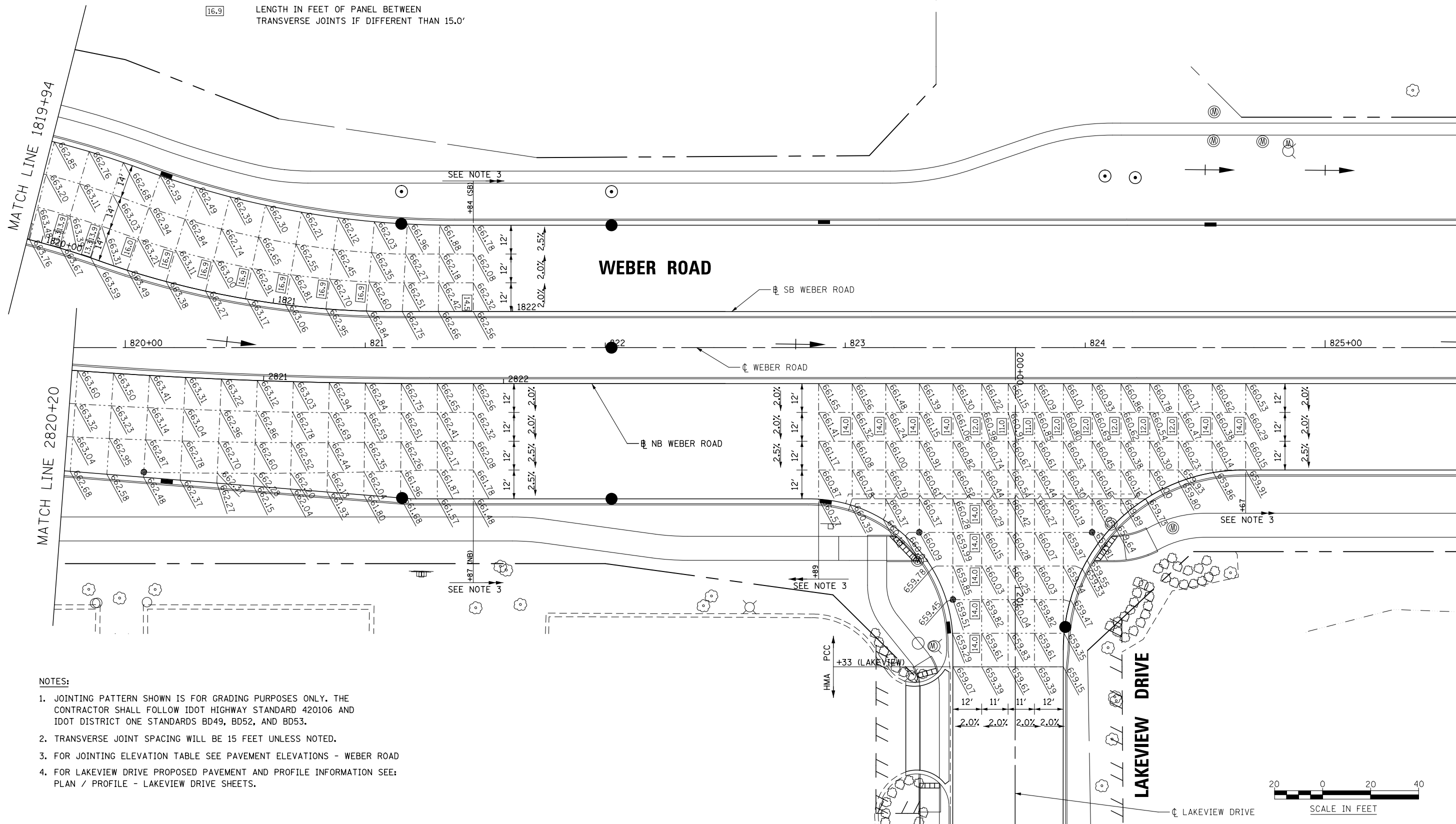

- NOTES:**
1. JOINTING PATTERN SHOWN IS FOR GRADING PURPOSES ONLY. THE CONTRACTOR SHALL FOLLOW IDOT HIGHWAY STANDARD 420106 AND IDOT DISTRICT ONE STANDARDS BD49, BD52, AND BD53.
 2. TRANSVERSE JOINT SPACING WILL BE 15 FEET UNLESS NOTED.
 3. FOR JOINTING ELEVATION TABLE SEE PAVEMENT ELEVATIONS - WEBER ROAD
 4. FOR LAKEVIEW DRIVE PROPOSED PAVEMENT AND PROFILE INFORMATION SEE: PLAN / PROFILE - LAKEVIEW DRIVE SHEETS.



FILE NAME = 60210-shr-pvt-joint06-Lakeview.dgn

KNIGHT Engineers & Architects	USER NAME = dbarnes	DESIGNED WVN	REVISED -
	PLOT SCALE = 1:40	DRAWN WVN	REVISED -
	PLOT DATE = 9/21/2017	CHECKED PJO	REVISED -
		DATE 11/15/17	REVISED -

**STATE OF ILLINOIS
DEPARTMENT OF TRANSPORTATION**

INTERSECTION DETAIL WEBER ROAD AND LAKEVIEW DRIVE		
SCALE: AS SHOWN	SHEET NO. 6 OF 11 SHEETS	STA. 819+75 TO STA. 825+50

F.A.I./P RTE. *	SECTION (99-1HB-1) R-1	COUNTY WILL	TOTAL SHEETS 1508	SHEET NO. 515
			CONTRACT NO. 60X10	
* FAI 55, FAP 856 [ILLINOIS] FED. AID PROJECT				

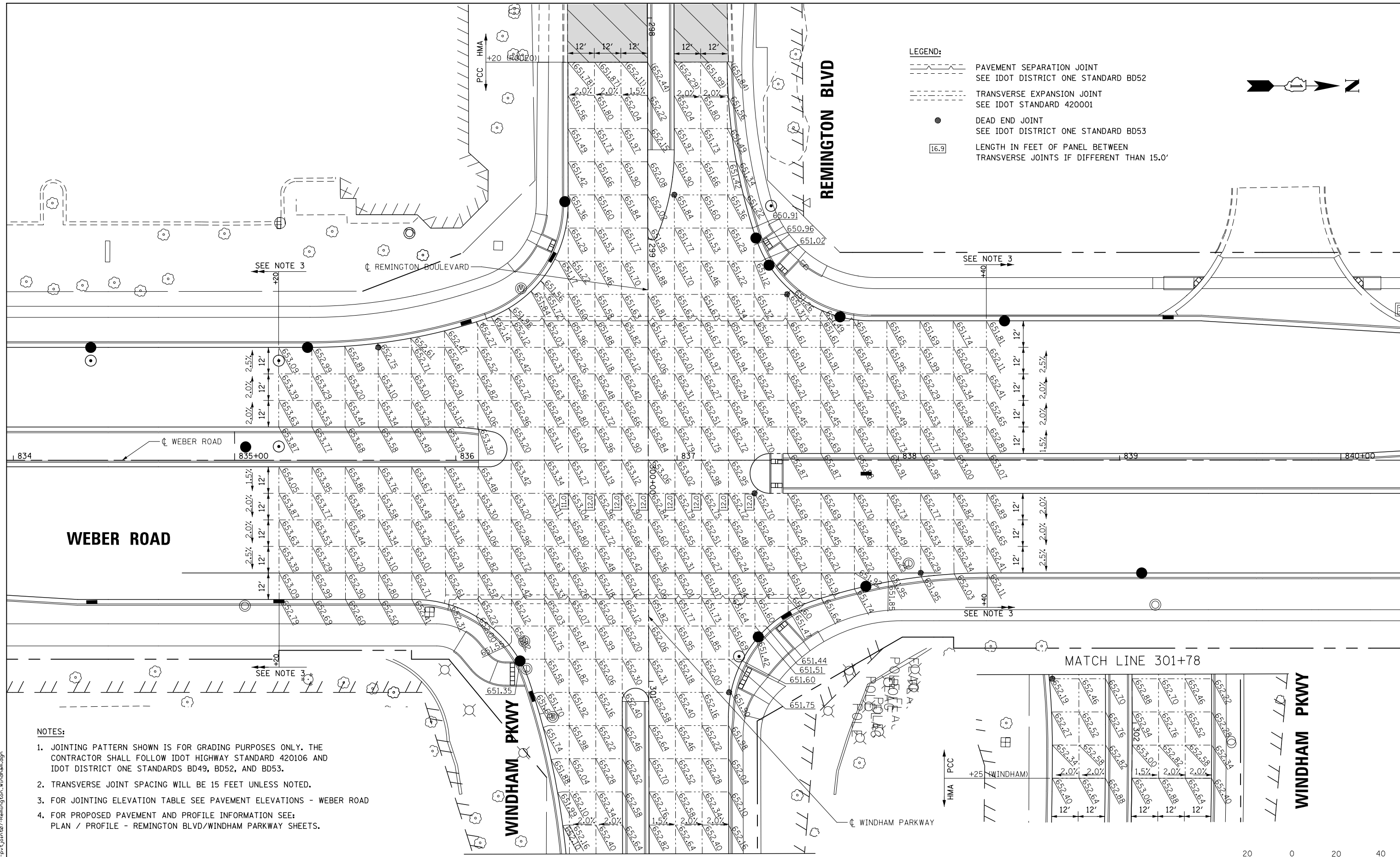

LEGEND:

- PAVEMENT SEPARATION JOINT
SEE IDOT DISTRICT ONE STANDARD BD52
- TRANSVERSE EXPANSION JOINT
SEE IDOT STANDARD 420001
- DEAD END JOINT
SEE IDOT DISTRICT ONE STANDARD BD53
- 16.9 LENGTH IN FEET OF PANEL BETWEEN TRANSVERSE JOINTS IF DIFFERENT THAN 15.0'

NOTES:

1. JOINTING PATTERN SHOWN IS FOR GRADING PURPOSES ONLY. THE CONTRACTOR SHALL FOLLOW IDOT HIGHWAY STANDARD 420106 AND IDOT DISTRICT ONE STANDARDS BD49, BD52, AND BD53.
2. TRANSVERSE JOINT SPACING WILL BE 15 FEET UNLESS NOTED.
3. FOR JOINTING ELEVATION TABLE SEE PAVEMENT ELEVATIONS - WEBER ROAD
4. FOR PROPOSED PAVEMENT AND PROFILE INFORMATION SEE: PLAN / PROFILE - REMINGTON BLVD/WINDHAM PARKWAY SHEETS.

FILE NAME = E0210-sht-pv-joint07-Remington_Windham.dgn

KNIGHT
Engineers & Architects

USER NAME = mmaestra	DESIGNED WVN	REVISED -
PLOT SCALE = 1:40	DRAWN WVN	REVISED -
PLOT DATE = 5/13/2017	CHECKED PJO	REVISED -
	DATE 05/12/17	REVISED -

STATE OF ILLINOIS
DEPARTMENT OF TRANSPORTATION

INTERSECTION DETAIL
WEBER ROAD & REMINGTON BLVD / WINDHAM PKWY
SCALE: AS SHOWN SHEET NO. 7 OF 11 SHEETS STA. 834+00 TO STA. 840+00

F.A.I./P RTE.	SECTION	COUNTY	TOTAL SHEETS	SHEET NO.
*	(99-1HB-1) R-1	WILL	1508	516
CONTRACT NO. 60X10				
* FAI 55, FAP 856 [ILLINOIS] FED. AID PROJECT				



- LEGEND:**
- PAVEMENT SEPARATION JOINT
SEE IDOT DISTRICT ONE STANDARD BD52
 - TRANSVERSE EXPANSION JOINT
SEE IDOT STANDARD 420001
 - DEAD END JOINT
SEE IDOT DISTRICT ONE STANDARD BD53
 - LENGTH IN FEET OF PANEL BETWEEN
TRANSVERSE JOINTS IF DIFFERENT THAN 15.0'

- NOTES:**
1. JOINTING PATTERN SHOWN IS FOR GRADING PURPOSES ONLY. THE CONTRACTOR SHALL FOLLOW IDOT HIGHWAY STANDARD 420106 AND IDOT DISTRICT ONE STANDARDS BD49, BD52, AND BD53.
 2. TRANSVERSE JOINT SPACING WILL BE 15 FEET UNLESS NOTED.
 3. FOR JOINTING ELEVATION TABLE SEE PAVEMENT ELEVATIONS - WEBER ROAD
 4. FOR RODEO DRIVE/ REMINGTON BLVD PROPOSED PAVEMENT AND PROFILE INFORMATION SEE PLAN / PROFILE - RODEO/REMINGTON DRIVE SHEETS.

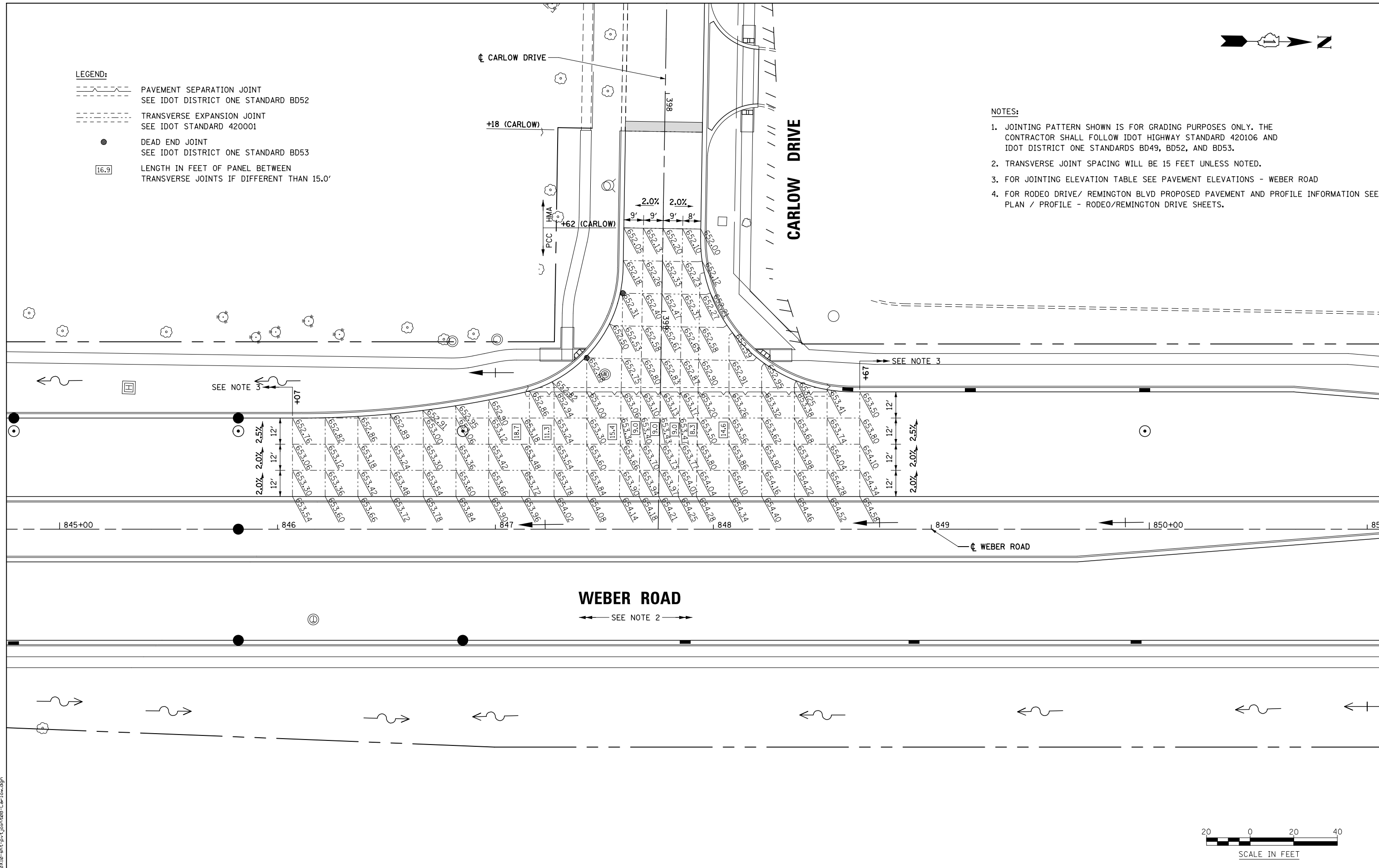

FILE NAME = 60X10-shr-pvt-joint08-Carlow.dgn



USER NAME = mmaestra	DESIGNED WVN	REVISED -
DRAWN WVN	REVISIONS	REVISED -
PLOT SCALE = 1:40	CHECKED PJO	REVISED -
PLOT DATE = 5/13/2017	DATE 05/12/17	REVISED -

**STATE OF ILLINOIS
DEPARTMENT OF TRANSPORTATION**

INTERSECTION DETAIL WEBER ROAD AND CARLOW DRIVE	
SCALE: AS SHOWN	SHEET NO. 8 OF 11 SHEETS
STA. 845+00	TO STA. 851+00

F.A.I./P RTE.	SECTION	COUNTY	TOTAL SHEETS	SHEET NO.
*	(99-1HB-1) R-1	WILL	1508	517
CONTRACT NO. 60X10			* FAI 55, FAP 856 ILLINOIS FED. AID PROJECT	



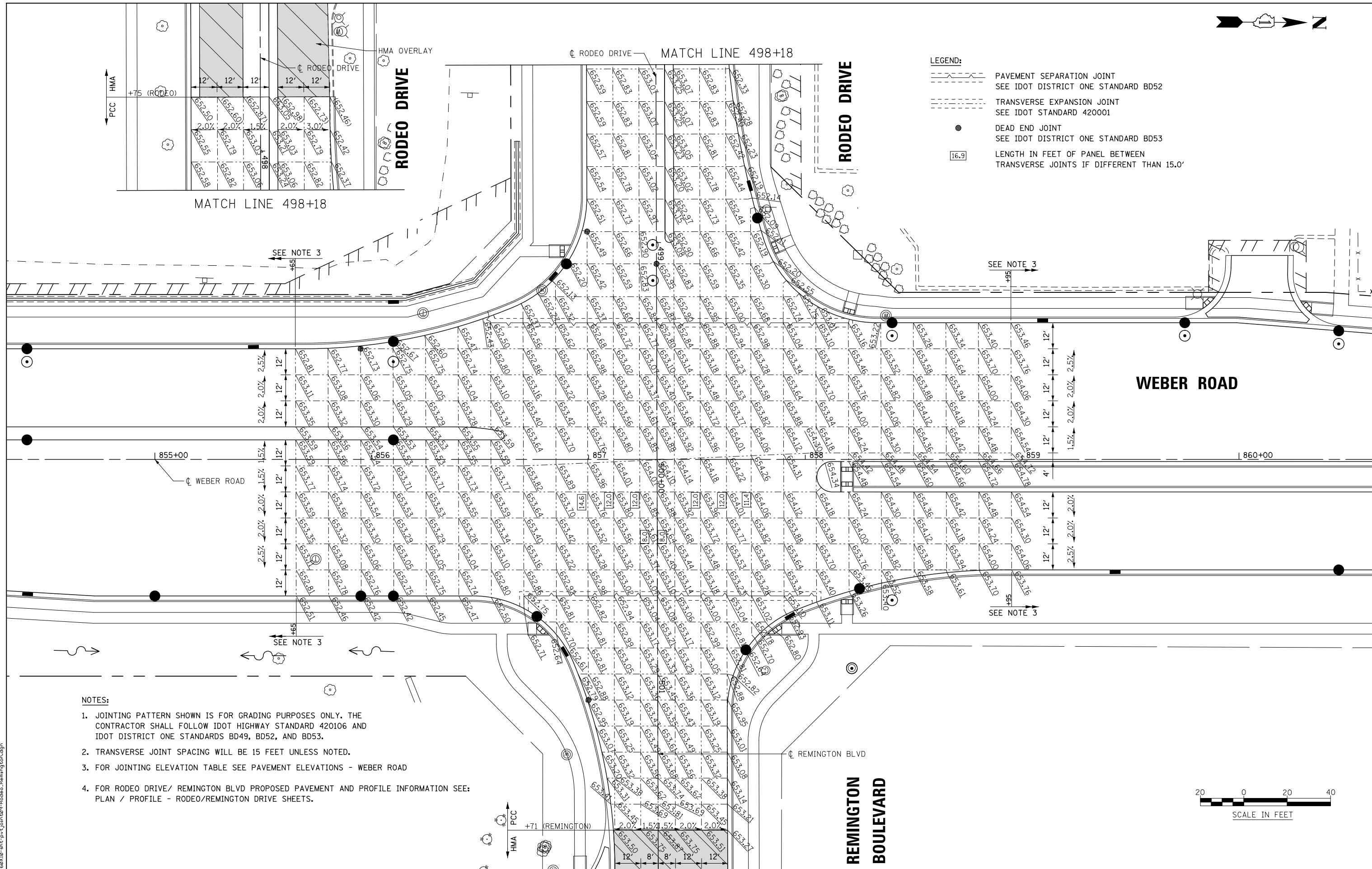
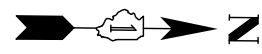

LEGEND:

	PAVEMENT SEPARATION JOINT SEE IDOT DISTRICT ONE STANDARD BD52
	TRANSVERSE EXPANSION JOINT SEE IDOT STANDARD 420001
	DEAD END JOINT SEE IDOT DISTRICT ONE STANDARD BD53
	LENGTH IN FEET OF PANEL BETWEEN TRANSVERSE JOINTS IF DIFFERENT THAN 15.0'

NOTES:

1. JOINTING PATTERN SHOWN IS FOR GRADING PURPOSES ONLY. THE CONTRACTOR SHALL FOLLOW IDOT HIGHWAY STANDARD 420106 AND IDOT DISTRICT ONE STANDARDS BD49, BD52, AND BD53.
2. TRANSVERSE JOINT SPACING WILL BE 15 FEET UNLESS NOTED.
3. FOR JOINTING ELEVATION TABLE SEE PAVEMENT ELEVATIONS - WEBER ROAD
4. FOR RODEO DRIVE/ REMINGTON BLVD PROPOSED PAVEMENT AND PROFILE INFORMATION SEE: PLAN / PROFILE - RODEO/REMINGTON DRIVE SHEETS.



FILE NAME = E0210-rht-pvt-joint03-Rodeo_Remington.dgn



USER NAME = mmaestra	DESIGNED WVN	REVISED -
PLOT SCALE = 1:40	DRAWN WVN	REVISED -
PLOT DATE = 5/15/2017	CHECKED PJO	REVISED -
	DATE 05/12/17	REVISED -

**STATE OF ILLINOIS
DEPARTMENT OF TRANSPORTATION**

**INTERSECTION DETAIL
WEBER ROAD AND RODEO DRIVE/REMINGTON BOULEVARD**

SCALE: AS SHOWN SHEET NO. 9 OF 11 SHEETS STA. 854+50 TO STA. 860+60

F.A.I./P RTE.	SECTION	COUNTY	TOTAL SHEETS	SHEET NO.
*	(99-1HB-1) R-1	WILL	1508	518
CONTRACT NO. 60X10			* FAI 55, FAP 856 [ILLINOIS] FED. AID PROJECT	

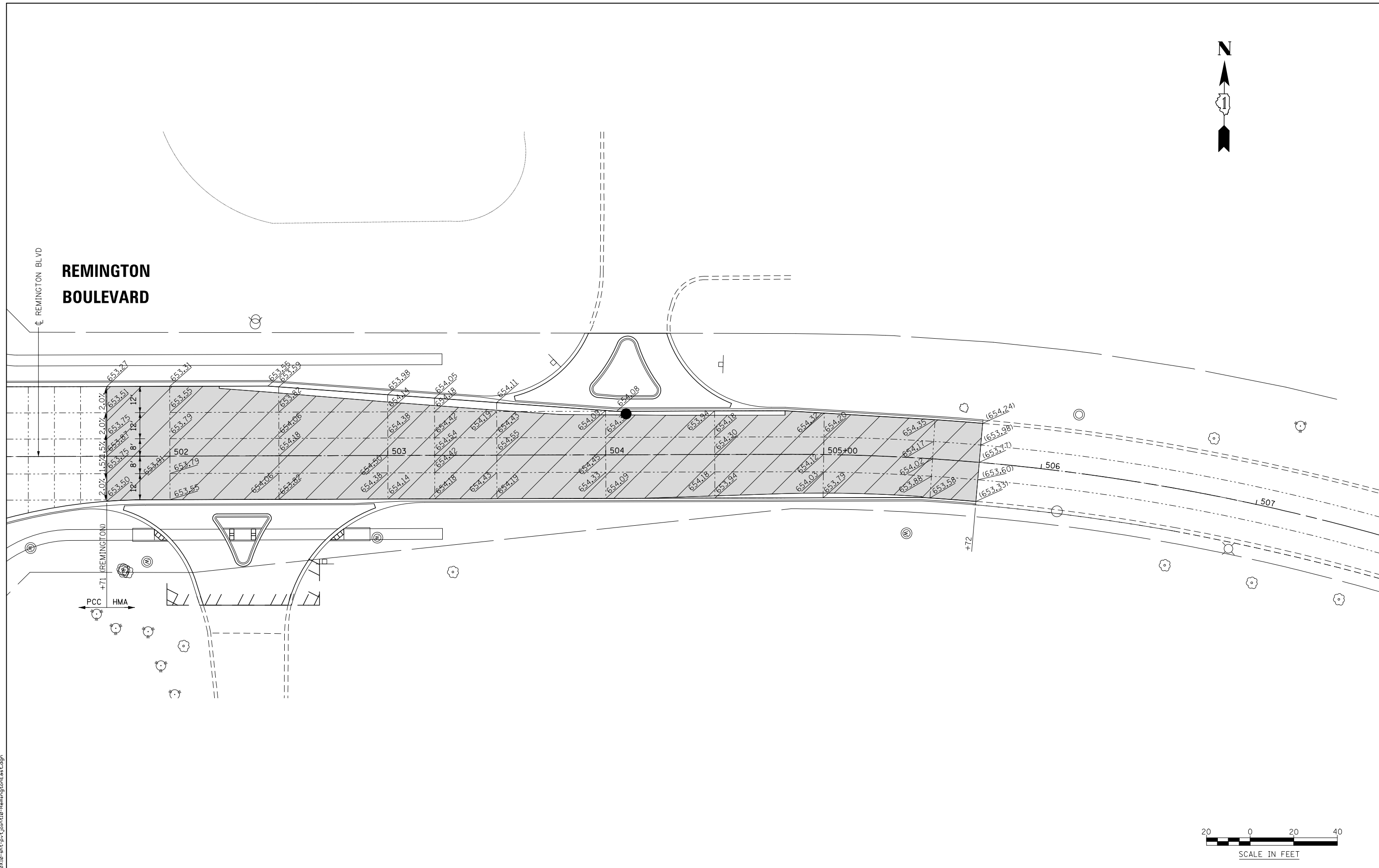

KNIGHT
Engineers & Architects

USER NAME = dbarnes	DESIGNED WVN	REVISED -
DRAWN WVN	DRAWN WVN	REVISED -
PLOT SCALE = 1:40	CHECKED PJO	REVISED -
PLOT DATE = 10/27/2017	DATE 11/15/17	REVISED -

**STATE OF ILLINOIS
DEPARTMENT OF TRANSPORTATION**

**INTERSECTION DETAIL
WEBER ROAD AND RODEO DRIVE/REMINGTON BOULEVARD (CONTINUED)**

SCALE: AS SHOWN | SHEET NO. 10 OF 11 SHEETS | STA. 501+33 TO STA. 505+72

F.A./P RTE.	SECTION	COUNTY	TOTAL SHEETS	SHEET NO.
*	(99-1HB-1) R-1	WILL	1508	519
CONTRACT NO. 60X10				
* FAI 55, FAP 856 ILLINOIS FED. AID PROJECT				

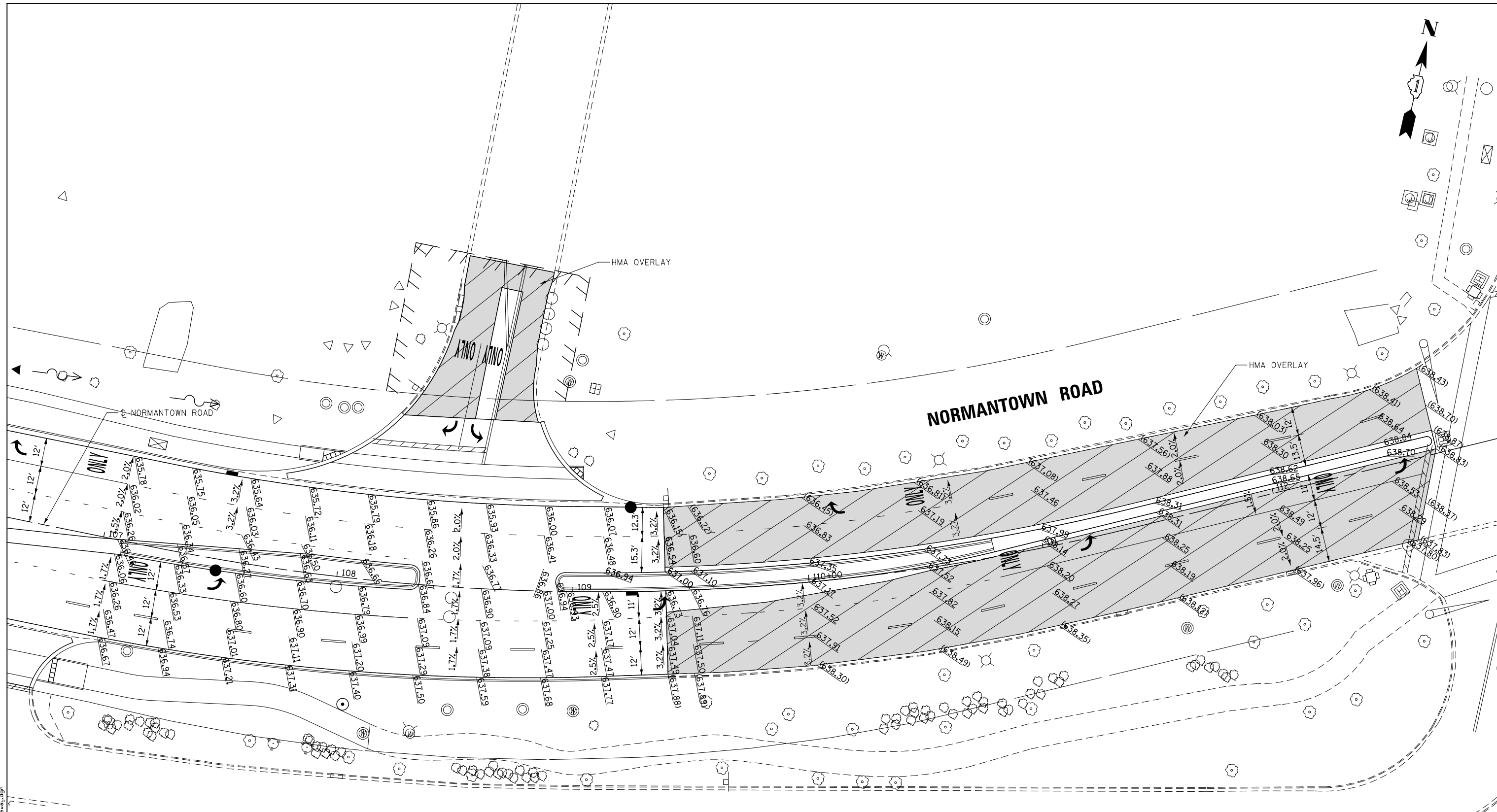

NOTES:
 1. FOR NORMANTOWN ROAD PROPOSED PAVEMENT AND PROFILE INFORMATION SEE:
 PLAN / PROFILE - NORMANTOWN ROAD SHEETS.

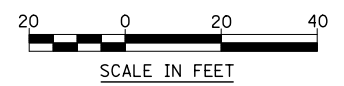

FILE NAME : E02410-shr-pvt-joint11-Normantown-Eastdrive.dgn

KNIGHT Engineers & Architects	USER NAME = mmaestra	DESIGNED WVN	REVISED -
	PLOT SCALE = 1:40	DRAWN WVN	REVISED -
	PLOT DATE = 5/13/2017	CHECKED PJO	REVISED -
		DATE 05/12/17	REVISED -

**STATE OF ILLINOIS
 DEPARTMENT OF TRANSPORTATION**

INTERSECTION DETAIL			
NORMANTOWN ROAD STA. 105+50 TO STA. 111+86			
SCALE: AS SHOWN	SHEET NO. 11 OF 11 SHEETS	STA. 105+50 TO STA. 111+86	

F.A.I./P RTE.	SECTION	COUNTY	TOTAL SHEETS	SHEET NO.
*	(99-1HB-1) R-1	WILL	1508	520
CONTRACT NO. 60X10				
* FAI 55, FAP 856 [ILLINOIS] FED. AID PROJECT				

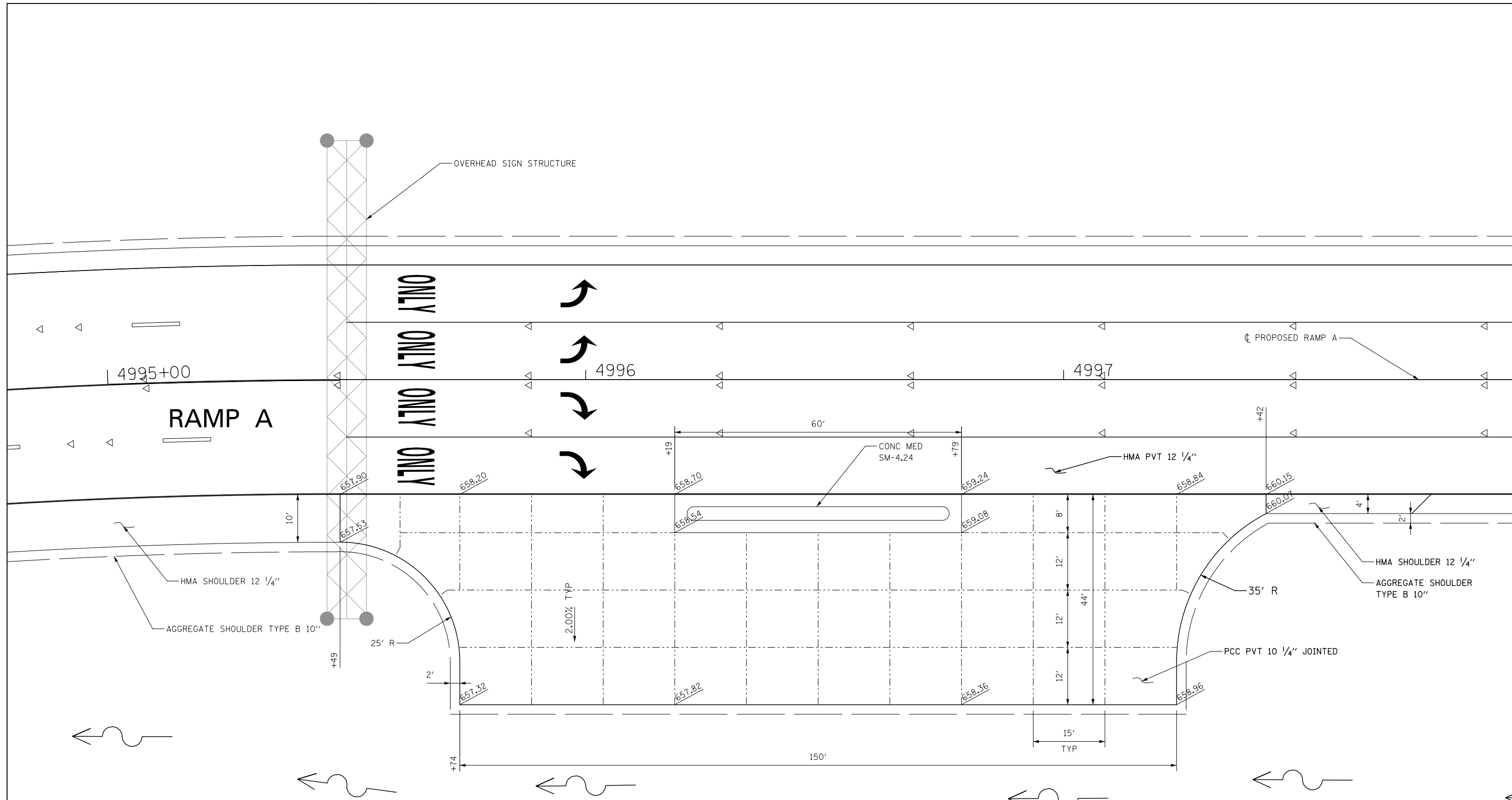

NOTES

- ELEVATIONS ARE FOR INFORMATION ONLY. CONTRACTOR SHALL VERIFY ALL ELEVATIONS PRIOR TO CONSTRUCTION.
- FOR JOINT DETAILS AND SPACING SEE STANDARDS 420001, 420101, 420106, 420201, AND 420401.
- FOR PROPOSED PAVEMENT MARKING & SIGNAGE INFORMATION SEE PAVEMENT MARKING AND SIGNING - RAMP A SHEETS.
- FOR PROPOSED GRADING AND DRAINAGE INFORMATION SEE INFIELD GRADING PLAN RAMP A AND PROPOSED DRAINAGE PLAN & PROFILE - RAMP A SHEETS.

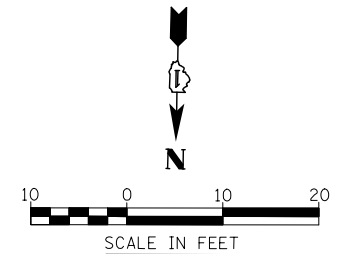

FILE NAME = 60X10-shr-pvt-joint12-Ramp A_CIS.dgn

	USER NAME = mmaestra	DESIGNED WVN	REVISED -	STATE OF ILLINOIS DEPARTMENT OF TRANSPORTATION	CRASH INVESTIGATION SITE RAMP A			F.A./P RTE.	SECTION	COUNTY	TOTAL SHEETS	SHEET NO.
	DRAWN WVN	REVISOR WVN	REVISED -		*	(99-1HB-1) R-1	WILL	1508	521			
PLOT SCALE = 1:20	CHECKED PJO	REVISOR PJO	REVISED -		SCALE: AS SHOWN SHEET NO. 1 OF 2 SHEETS STA. 4994+79 TO STA. 4997+94			CONTRACT NO. 60X10				
PLOT DATE = 5/13/2017	DATE 05/12/17	REVISED -	REVISED -		* FAI 55, FAP 856 [ILLINOIS] FED. AID PROJECT							

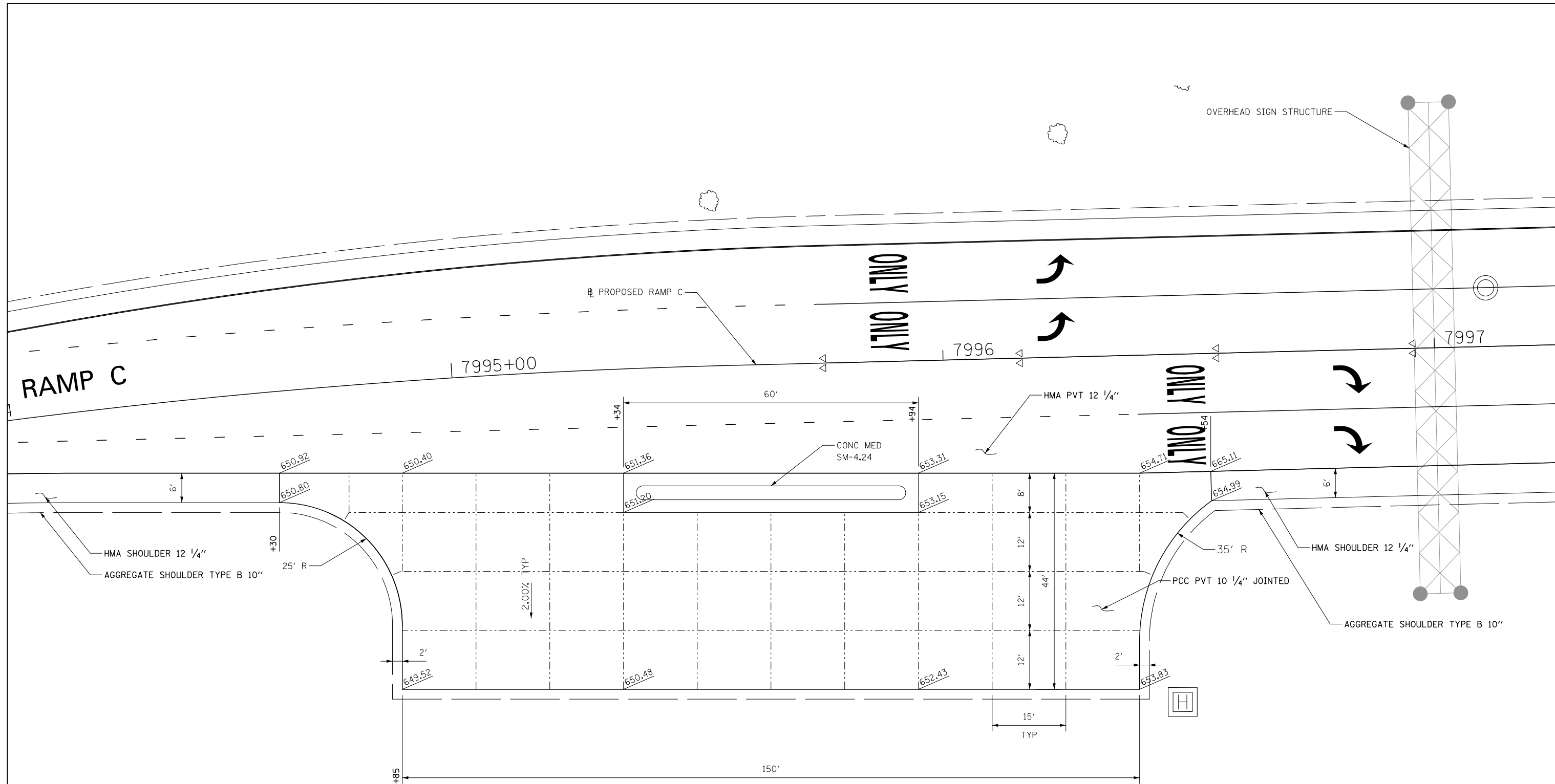

NOTES

- ELEVATIONS ARE FOR INFORMATION ONLY. CONTRACTOR SHALL VERIFY ALL ELEVATIONS PRIOR TO CONSTRUCTION.
- FOR JOINT DETAILS AND SPACING SEE STANDARDS 420001, 420101, 420106, 420201, AND 420401.
- FOR PROPOSED PAVEMENT MARKING & SIGNAGE INFORMATION SEE PAVEMENT MARKING AND SIGNING - RAMP C SHEETS.
- FOR PROPOSED GRADING AND DRAINAGE INFORMATION SEE INFIELD GRADING PLAN RAMP C AND PROPOSED DRAINAGE PLAN & PROFILE - RAMP C SHEETS.

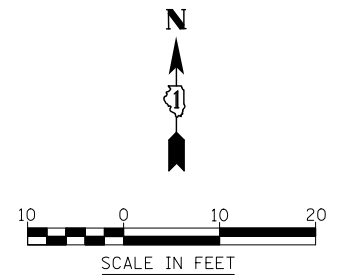

FILE NAME = 60X10-shr-pvt-joint13-Ramp_C_CIS.dgn

KNIGHT Engineers & Architects	USER NAME = mmaestra	DESIGNED WVN	REVISED -
	PLOT SCALE = 1:20	DRAWN WVN	REVISED -
	PLOT DATE = 5/13/2017	CHECKED PJO	REVISED -
		DATE 05/12/17	REVISED -

**STATE OF ILLINOIS
DEPARTMENT OF TRANSPORTATION**

**CRASH INVESTIGATION SITE
RAMP C**

SCALE: AS SHOWN SHEET NO. 2 OF 2 SHEETS STA. 7994+09 TO STA. 7997+25

F.A.I./P RTE. *	SECTION (99-1HB-1) R-1	COUNTY WILL	TOTAL SHEETS 1508	SHEET NO. 522
CONTRACT NO. 60X10				
* FAI 55, FAP 856 ILLINOIS FED. AID PROJECT				

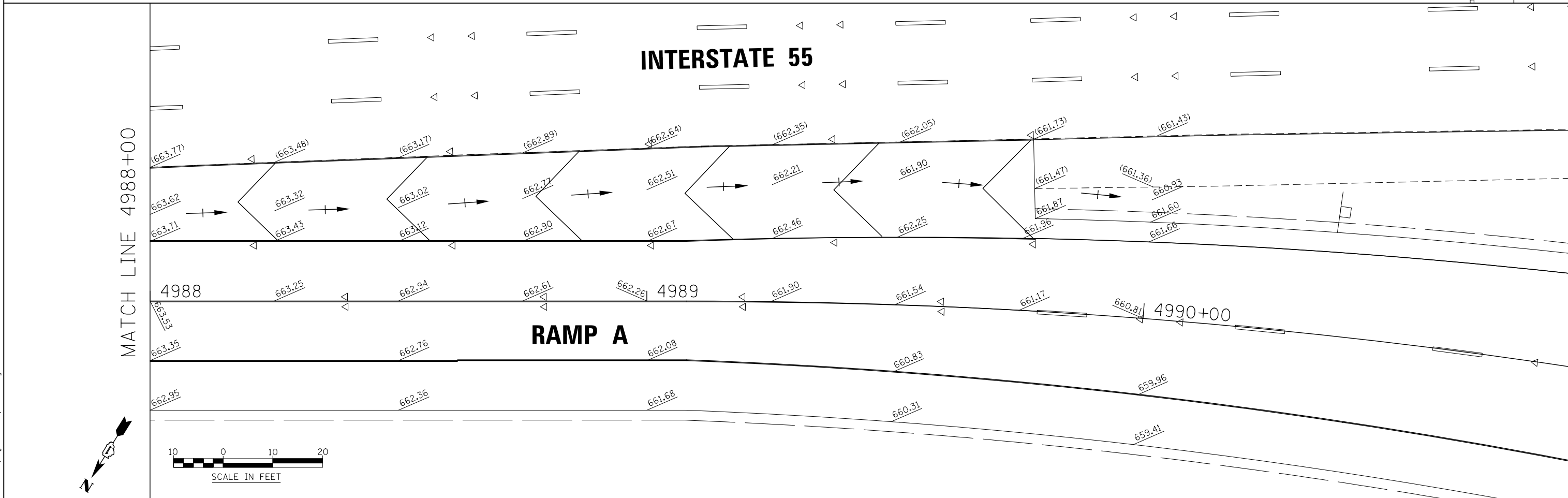
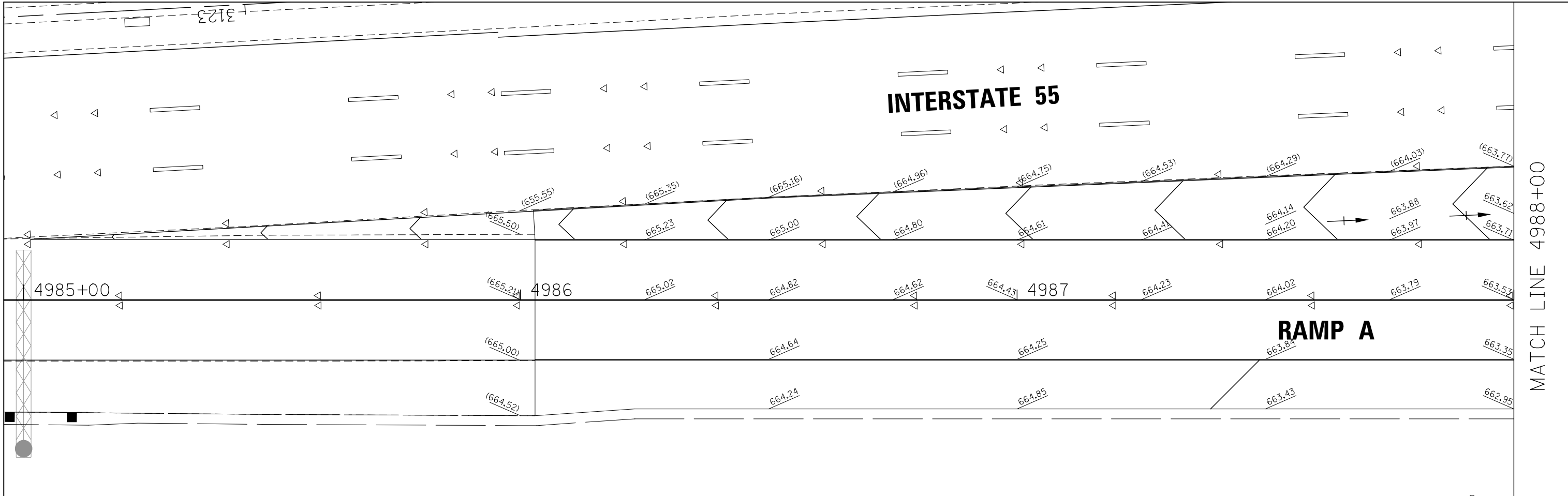

FILE NAME = 60210-shr-pv-joint14-Ramp A Gore.dgn

KNIGHT Engineers & Architects	USER NAME = mmaestra	DESIGNED DGB	REVISED -
	DRAWN DGB		REVISED -
	PLOT SCALE = 1:20	CHECKED PJO	REVISED -
	PLOT DATE = 5/13/2017	DATE 05/12/17	REVISED -

STATE OF ILLINOIS
DEPARTMENT OF TRANSPORTATION

GORE GRADING DETAILS
RAMP A

SCALE: AS SHOWN SHEET NO. 1 OF 4 SHEETS STA. 4985+00 TO STA. 4991+00

F.A.I./P RTE.	SECTION	COUNTY	TOTAL SHEETS	SHEET NO.
*	(99-1HB-1) R-1	WILL	1508	523
CONTRACT NO. 60X10				
<small>* FAI 55, FAP 856 [ILLINOIS] FED. AID PROJECT</small>				

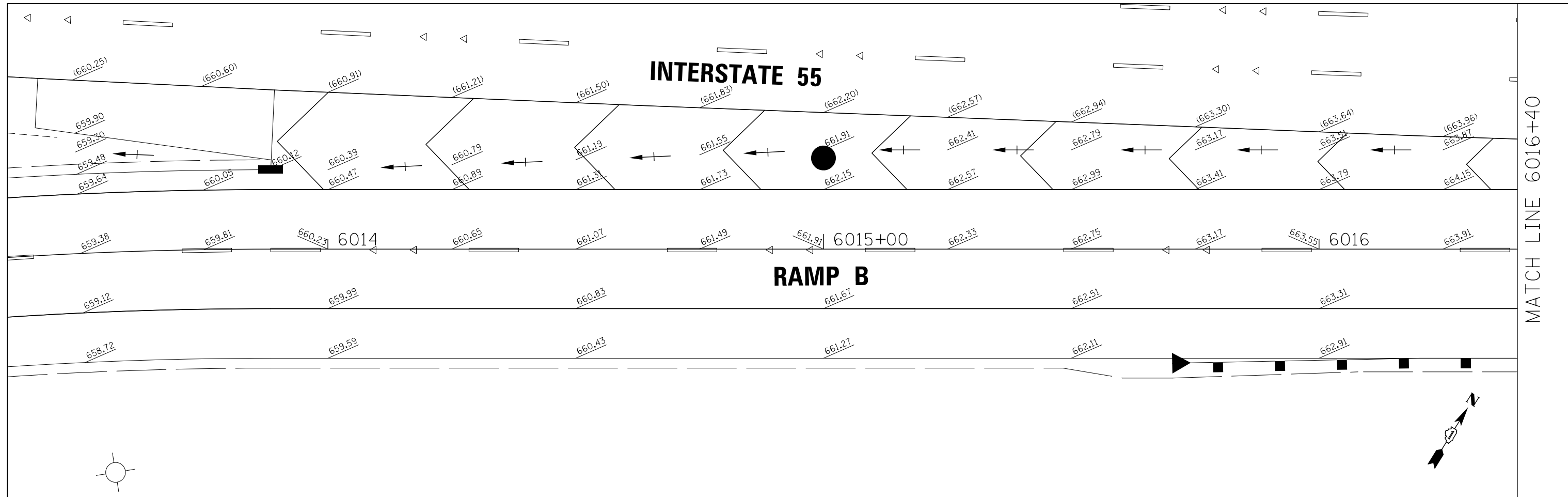

MATCH LINE 6016+40

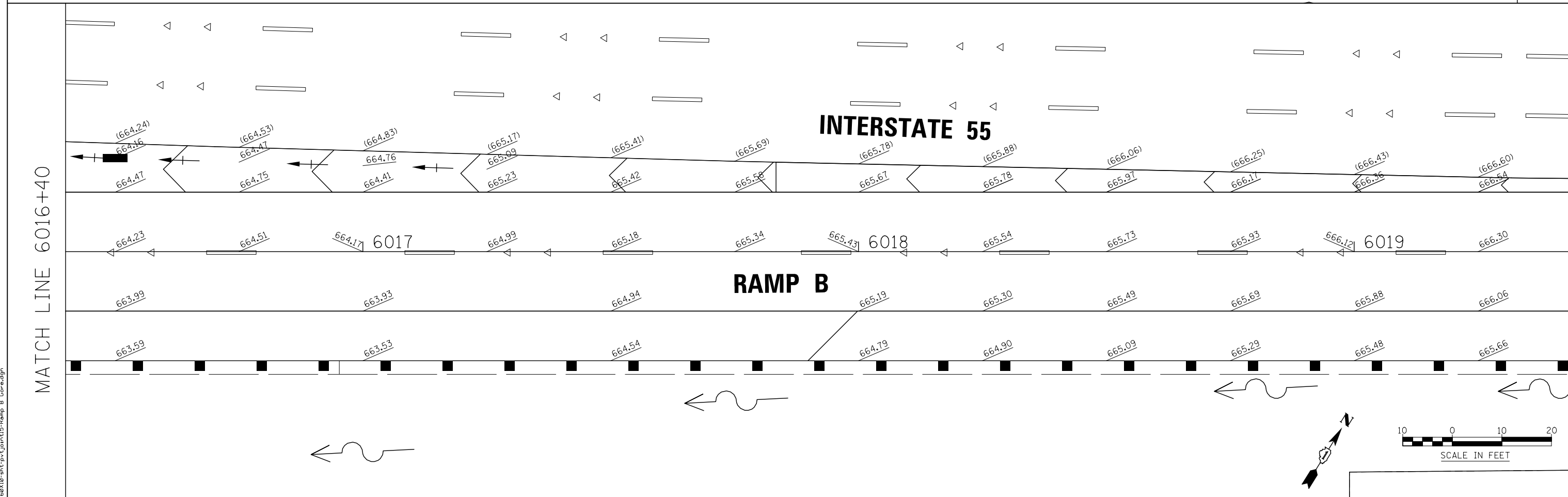

MATCH LINE 6016+40

FILE NAME = 6010-sht-pv-joint15-Ramp_B_Gore.dgn

KNIGHT Engineers & Architects	USER NAME = mmaestra	DESIGNED DGB	REVISED -
	PLOT SCALE = 1:20	DRAWN DGB	REVISED -
	PLOT DATE = 5/13/2017	CHECKED PJO	REVISED -
		DATE 05/12/17	REVISED -

STATE OF ILLINOIS
DEPARTMENT OF TRANSPORTATION

GORE GRADING DETAILS
RAMP B

SCALE: AS SHOWN SHEET NO. 2 OF 4 SHEETS STA. 6013+38 TO STA. 6016+50

F.A.I./P RTE.	SECTION	COUNTY	TOTAL SHEETS	SHEET NO.
*	(99-1HB-1) R-1	WILL	1508	524
CONTRACT NO. 60X10				
<small>* FAI 55, FAP 856 ILLINOIS FED. AID PROJECT</small>				

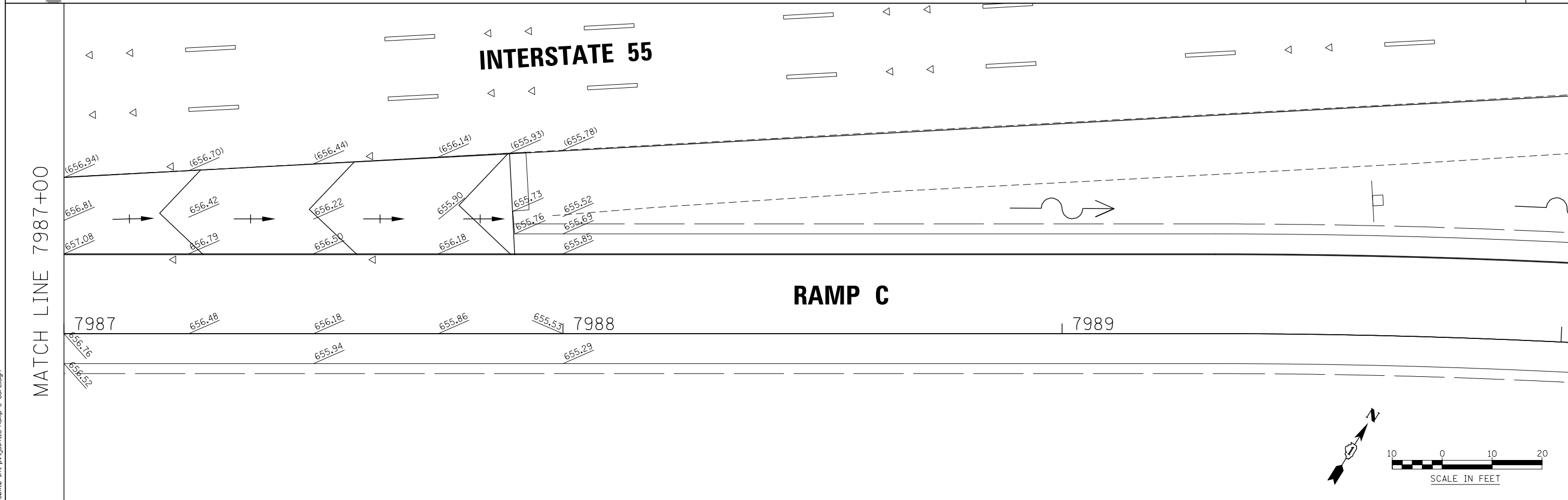
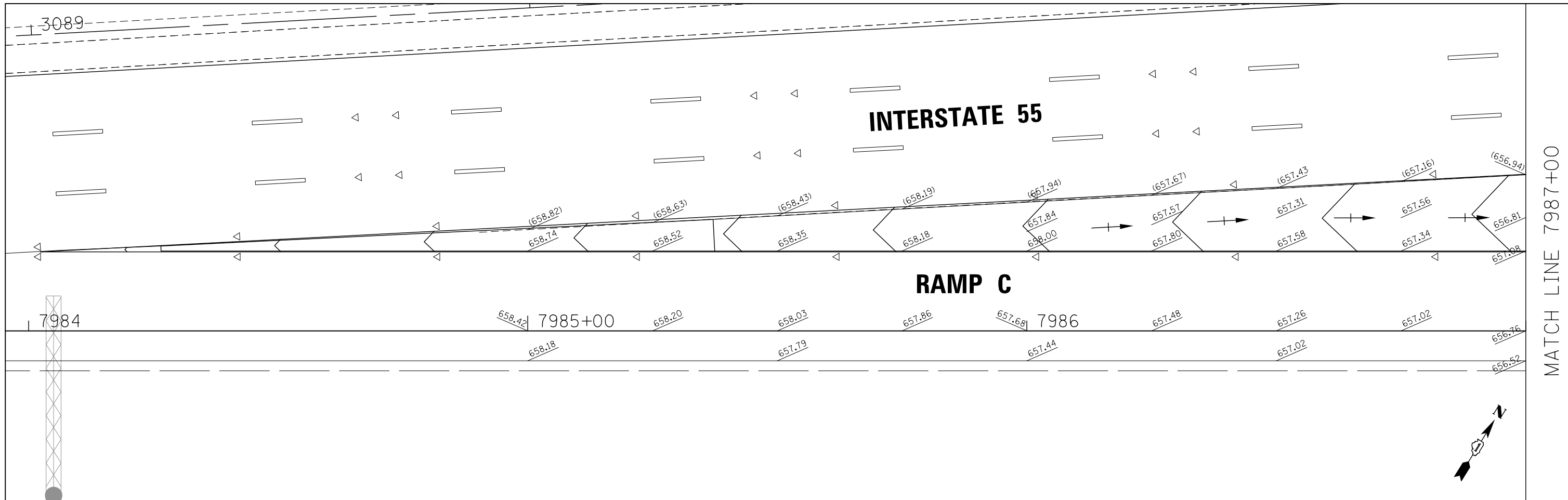

FILE NAME = 60X10-shr-pvt-joint16-Ramp_C_Gore.dgn

KNIGHT
Engineers & Architects

USER NAME = mmaestra	DESIGNED DGB	REVISED -
	DRAWN DGB	REVISED -
PLOT SCALE = 1:20	CHECKED PJO	REVISED -
PLOT DATE = 5/13/2017	DATE 05/12/17	REVISED -

STATE OF ILLINOIS
DEPARTMENT OF TRANSPORTATION

GORE GRADING PLAN
RAMP C

SCALE: AS SHOWN SHEET NO. 3 OF 4 SHEETS STA. 7983+95 TO STA. 7987+10

F.A.I./P RTE.	SECTION	COUNTY	TOTAL SHEETS	SHEET NO.
*	(99-1HB-1) R-1	WILL	1508	525
CONTRACT NO. 60X10				
* FAI 55, FAP 856 [ILLINOIS] FED. AID PROJECT				

MATCH LINE 7987+00

MATCH LINE 7987+00

FILE NAME = 60X10-shr-pvt-joint17-Ramp D Gore.dgn

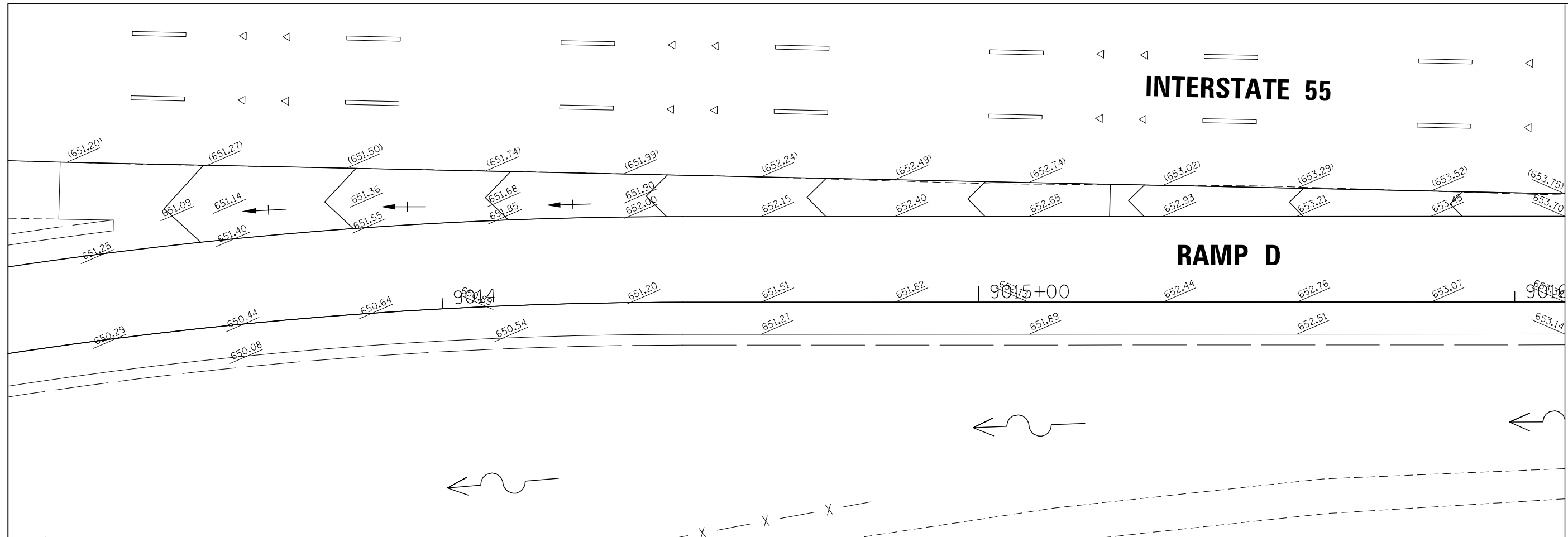

MATCH LINE 9016+00

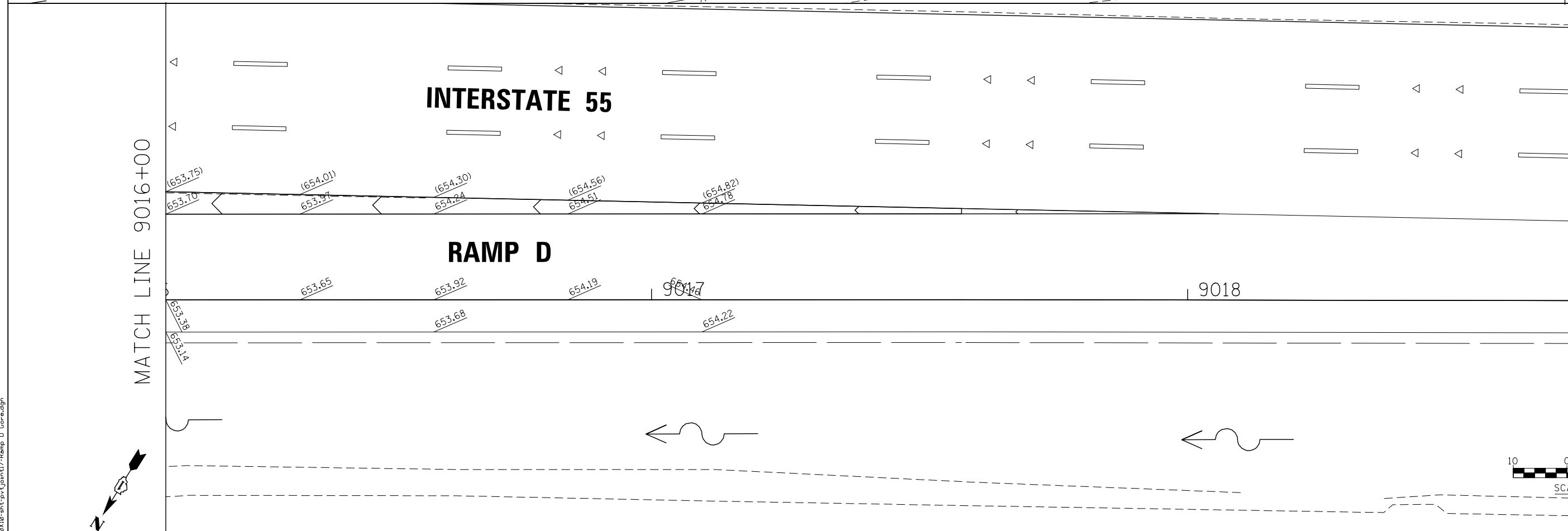

MATCH LINE 9016+00

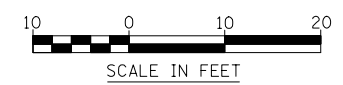

KNIGHT
Engineers & Architects

USER NAME = mmaestra	DESIGNED DGB	REVISED -
	DRAWN DGB	REVISED -
PLOT SCALE = 1:20	CHECKED PJO	REVISED -
PLOT DATE = 5/13/2017	DATE 05/12/17	REVISED -

STATE OF ILLINOIS
DEPARTMENT OF TRANSPORTATION

GORE GRADING DETAILS
RAMP D

SCALE: AS SHOWN SHEET NO. 4 OF 4 SHEETS STA. 9013+08 TO STA. 9016+24

F.A.I./P RTE. *	SECTION (99-1HB-1) R-1	COUNTY WILL	TOTAL SHEETS 1508	SHEET NO. 526
CONTRACT NO. 60X10				
* FAI 55, FAP 856 ILLINOIS FED. AID PROJECT				

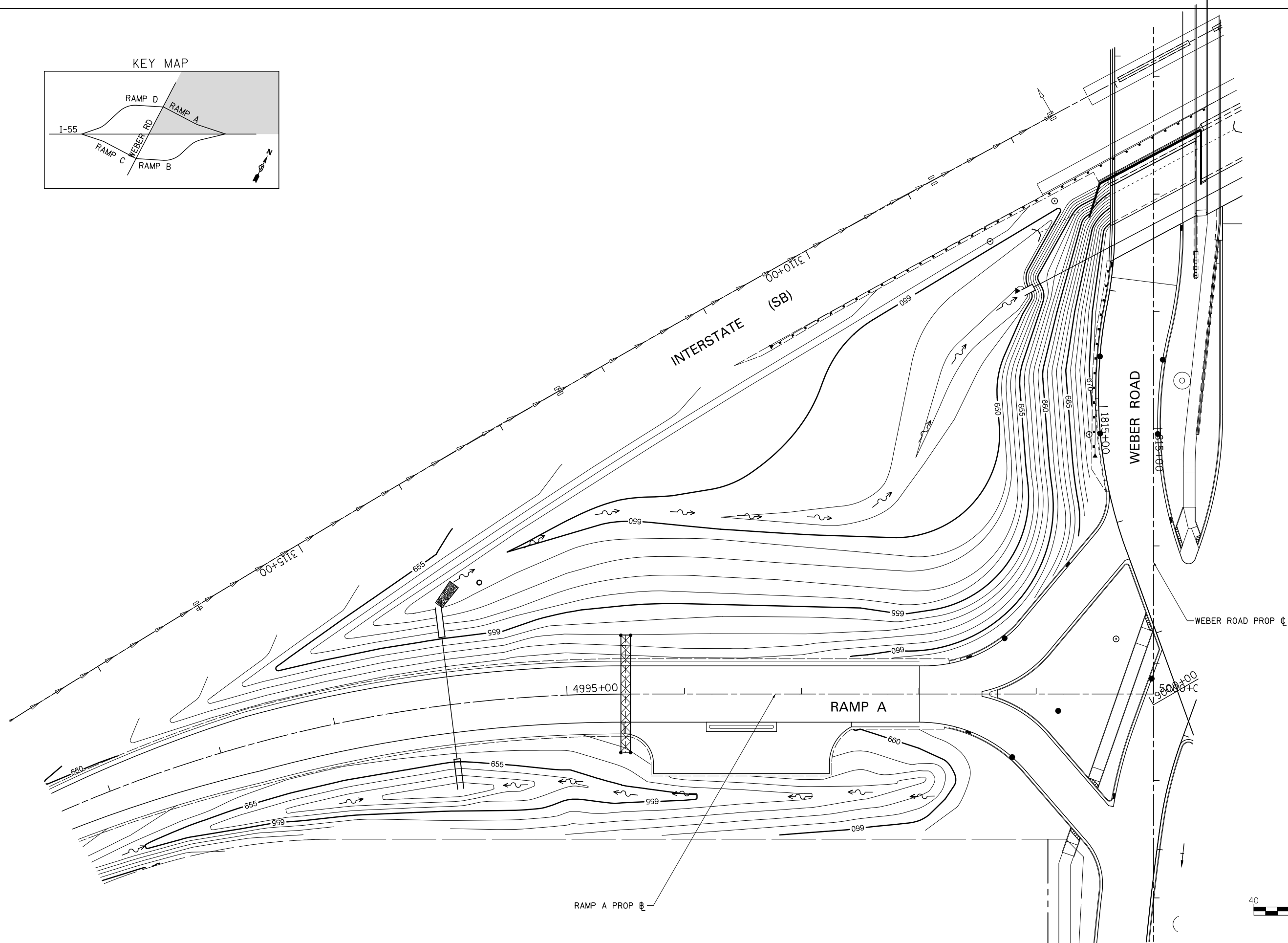
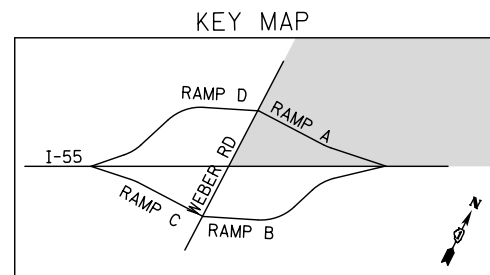

FILE NAME : D:\60X10-shr-plan\01-Inf\field\grading.dgn

KNIGHT
Engineers & Architects

USER NAME = mmaestra	DESIGNED DGB	REVISED -
	DRAWN DGB	REVISED -
PLOT SCALE = 1:80	CHECKED PJO	REVISED -
PLOT DATE = 5/13/2017	DATE 05/12/17	REVISED -

STATE OF ILLINOIS
DEPARTMENT OF TRANSPORTATION

INFIELD GRADING PLANS RAMP A	
SCALE: AS SHOWN	SHEET NO. 1 OF 4 SHEETS
STA.	TO STA.

F.A.I./P RTE.	SECTION	COUNTY	TOTAL SHEETS	SHEET NO.
*	(99-1HB-1) R-1	WILL	1508	527
CONTRACT NO. 60X10				
* FAI 55, FAP 856 ILLINOIS FED. AID PROJECT				

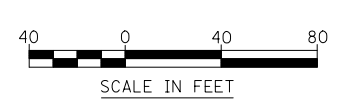
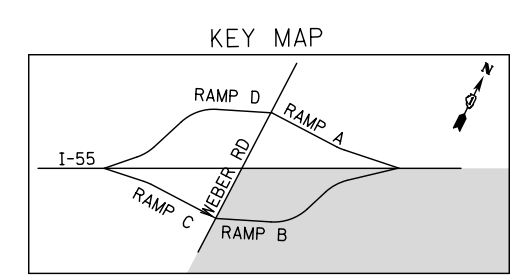
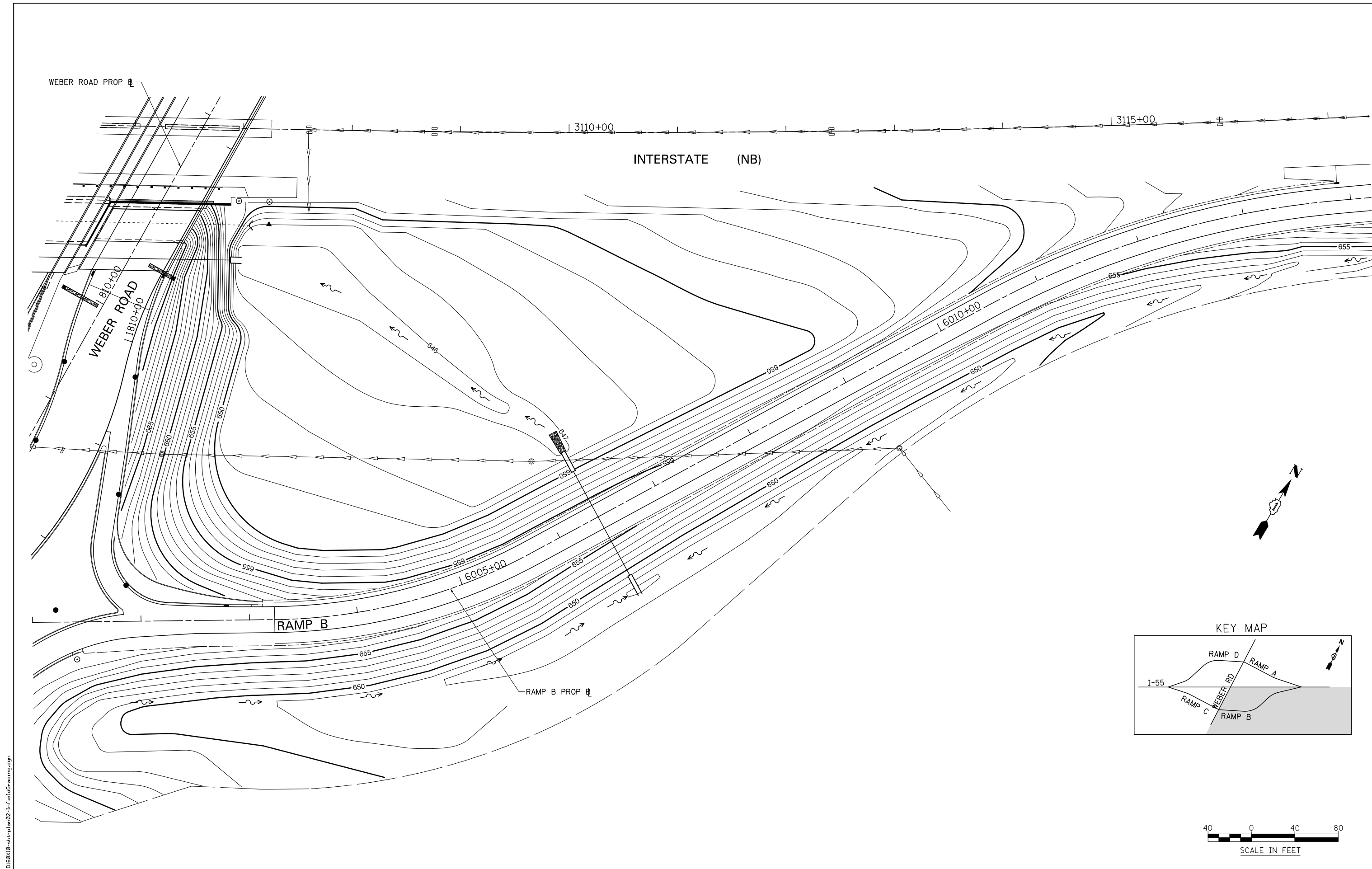

FILE NAME : D:\60X10-shr-plan-02-infield\grading.dgn

KNIGHT Engineers & Architects	USER NAME = mmaestra	DESIGNED DGB	REVISED -
	PLOT SCALE = 1:80	DRAWN DGB	REVISED -
	PLOT DATE = 5/13/2017	CHECKED PJO	REVISED -
		DATE 05/12/17	REVISED -

**STATE OF ILLINOIS
DEPARTMENT OF TRANSPORTATION**

**INFIELD GRADING PLANS
RAMP B**

SCALE: AS SHOWN SHEET NO. 2 OF 4 SHEETS STA. TO STA.

F.A.I./P RTE.	SECTION	COUNTY	TOTAL SHEETS	SHEET NO.
*	(99-1HB-1) R-1	WILL	1508	528
CONTRACT NO. 60X10				
* FAI 55, FAP 856 [ILLINOIS] FED. AID PROJECT				

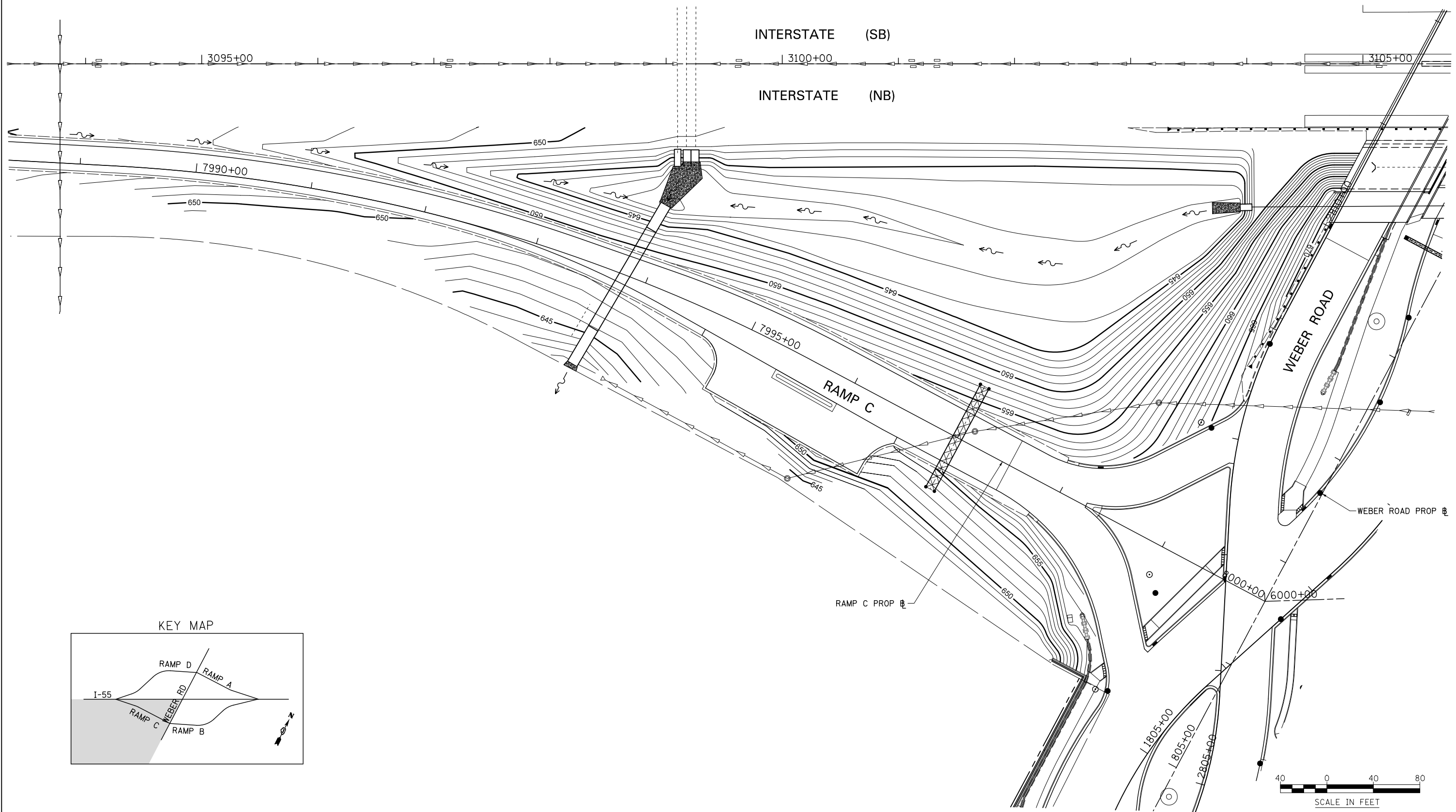

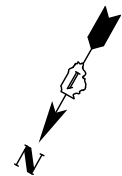

INTERSTATE (NB)

INTERSTATE (SB)

WEBER ROAD PROP

WEBER ROAD

RAMP D

RAMP D PROP

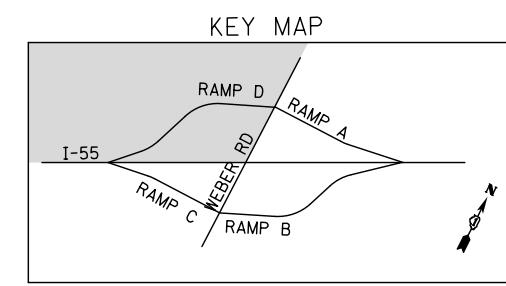

FILE NAME : D:\60X10-shr-plan\04-infield\grading.dgn

KNIGHT
Engineers & Architects

USER NAME = mmaestra	DESIGNED DGB	REVISED -
PLOT SCALE = 1:80	DRAWN DGB	REVISED -
PLOT DATE = 5/13/2017	CHECKED PJO	REVISED -
	DATE 05/12/17	REVISED -

STATE OF ILLINOIS
DEPARTMENT OF TRANSPORTATION

INFIELD GRADING PLANS
RAMP D

SCALE: AS SHOWN SHEET NO. 4 OF 4 SHEETS STA. TO STA.

F.A./P RTE.	SECTION	COUNTY	TOTAL SHEETS	SHEET NO.
*	(99-1HB-1) R-1	WILL	1508	530
CONTRACT NO. 60X10				
* FAI 55, FAP 856 [ILLINOIS] FED. AID PROJECT				

FILE NAME : D:\60X10-shr-drain\01-Existing Structure Schedule-01.dgn

STRUCTURE NUMBER	LOCATION		RIM ELEVATION	INVERT							DESCRIPTION	
	STATION	OFFSET		N	NE	E	SE	S	SW	W		NW
101 #	791+96	36 LT	621.00	615.40	616.20			615.36				REMOV MANHOLES
101A	789+00	50 LT	N/A							614.17		FL END SEC INFO ONLY
102 #	792+00	29 LT	620.74	616.48					616.44			REMOV INLETS
103 #	793+64	2 LT	623.49						--			REMOV CATCH BAS
104 #	794+56	40 LT	625.42	618.85	620.32			618.77				REMOV MANHOLES
105 #	794+69	34 LT	625.58			620.73			620.73			REMOV INLETS
106 #	794+69	31 RT	625.56							622.59		REMOV INLETS
107 #	796+90	40 LT	632.35	626.25		627.00		626.17				REMOV MANHOLES
108 #	796+92	35 LT	632.24			--				627.62		REMOV INLETS
109 #	797+30	43 RT	633.07						630.13			REMOV INLETS
110 #	798+84	46 LT	638.10	632.45				632.40				REMOV MANHOLES
111 #	800+98	40 LT	644.67	639.54	639.77			639.51				REMOV MANHOLES
112 #	801+05	34 LT	644.70			640.15			640.10			REMOV INLETS
113 #	801+18	32 RT	644.81							642.22		REMOV INLETS
114 #	803+49	39 LT	652.27	647.78	647.72			647.75				REMOV MANHOLES
115 #	803+54	33 LT	652.08		--	--			648.16			REMOV INLETS
116 #	803+55	44 RT	651.73							648.80		REMOV INLETS
117 #	804+34	2 RT	655.37						652.27			REMOV MANHOLES
118 #	806+40	40 LT	661.00	655.40		655.50		655.40				REMOV MANHOLES
119 #	806+34	34 LT	660.45			655.69				655.76		REMOV INLETS
120 #	806+41	33 RT	660.56							657.18		REMOV INLETS
121 #	808+58	41 LT	667.01		662.34			662.04				REMOV MANHOLES
122 #	808+66	34 LT	667.10			662.26			662.34			REMOV INLETS
123 #	808+64	33 RT	667.02							663.53		REMOV INLETS
124 #	792+00	26 RT	620.71			617.16						REMOV INLETS
125	791+99	42 RT	N/A							615.87		REMOV EX FLAR END SEC
126	794+32	54 RT	N/A	621.04								REMOV EX FLAR END SEC
127 #	800+70	83 RT	640.31	636.05				633.95				REMOV CATCH BAS
128	802+78	88 RT	645.27	641.32				641.32				REMOV MANHOLES
129 #	803+42	80 RT	646.89					642.59				REMOV MANHOLES
130	799+12	66 LT	N/A	635.00								REMOV EX FLAR END SEC
131	800+58	72 LT	N/A					637.34				REMOV EX FLAR END SEC
131A	98+94	86 LT	645.07				638.12				638.12	CB INFO ONLY
131B	98+79	35 LT	640.01			636.46						REMOV INLETS
131C	98+91	35 LT	640.06				636.01			636.06		REMOV INLETS
131D	98+80	34 RT	639.75	636.77								REMOV INLETS
131E	98+79	0 RT	640.72			636.08		636.60				REMOV CATCH BAS
131F	99+25	0 RT	641.25					636.33		636.27	636.29	REMOV MANHOLES
131G	99+24	54 RT	N/A	635.61								REMOV EX FLAR END SEC
132	811+30	82 RT	N/A							644.68		CONC HDWL REM
132A	811+65	124 RT	N/A	645.46								CONC HDWL REM
133	810+37	92 LT	N/A			643.53						CONC HDWL REM
134	813+34	98 RT	N/A							646.80		CONC HDWL REM
135	812+45	69 LT	N/A			646.28						CONC HDWL REM
136 #	814+64	33 RT	669.95							667.17		REMOV INLETS
137 #	814+63	38 LT	669.69			664.72					664.40	REMOV INLETS
138 #	814+71	45 LT	670.10	664.44			664.50					REMOV MANHOLES
139 #	817+14	46 LT	664.86	659.36	659.57			659.14				REMOV MANHOLES
140 #	817+21	40 LT	664.36			660.48			659.33			REMOV INLETS
141 #	817+22	33 RT	664.43							660.94		REMOV INLETS
142 #	820+57	49 LT	662.81	657.73		658.92		657.87				REMOV MANHOLES

STRUCTURE NUMBER	LOCATION		RIM ELEVATION	INVERT							DESCRIPTION	
	STATION	OFFSET		N	NE	E	SE	S	SW	W		NW
143 #	820+58	45 LT	662.39		658.99	658.76					658.87	REMOV INLETS
144 #	820+49	38 RT	662.49								659.57	REMOV INLETS
145	820+64	3 LT	663.53								659.43	REMOV CATCH BAS
146 #	822+80	38 LT	662.14			657.73	--	656.30				REMOV MANHOLES
147 #	822+73	34 LT	661.56								657.77	REMOV INLETS
148 #	822+78	50 RT	661.77	656.79					658.24	657.09		REMOV MANHOLES
149 #	822+72	45 RT	661.39		658.45							REMOV INLETS
150	824+11	74 RT	659.99	641.66	646.47						641.44	MAN ADJUST
151 #	825+92	36 RT	659.68	654.68				654.75	654.78			REMOV MANHOLES
152 #	825+86	33 RT	659.39		654.97						654.64	REMOV INLETS
153 #	825+85	34 LT	659.30			656.55						REMOV INLETS
154 #	828+03	39 RT	658.52			652.62		652.47	652.67			REMOV MANHOLES
155 #	827+87	33 RT	658.18		652.76						652.83	REMOV INLETS
156 #	827+86	33 LT	658.24			654.14						REMOV INLETS
157 #	830+62	41 LT	656.53			653.53						REMOV INLETS
158 #	830+52	39 RT	656.50			--					653.03	REMOV INLETS
158A	830+58	66 RT	N/A									**PLUG PIPE PENETRATION
159 #	832+63	60 LT	655.20			--						REMOV INLETS
160 #	832+63	43 RT	655.20			652.51					652.51	REMOV INLETS
161 #	835+00	43 LT	653.06			649.16						REMOV INLETS
162 #	835+05	50 RT	652.99			--					650.00	REMOV INLETS
162A#	836+35	71 RT	651.41								648.46	REMOV INLETS
162B	836+37	64 RT	N/A									**PLUG PIPE PENETRATION
163	836+25	121 LT	651.00	647.52					647.24			CB INFO ONLY
164	836+49	117 LT	651.47	647.22		647.97		647.38				REMOV INLETS
165	836+49	109 LT	651.38								648.58	REMOV INLETS
166	837+31	116 LT	651.34	646.87		647.69		647.04				REMOV INLETS
166A	298+85	56 LT	651.27	647.08				646.44		646.41		REMOV MANHOLES
166C	295+66	51 LT	651.41	646.46		646.31		646.31		646.31		MH INFO ONLY
167 #	837+33	108 LT	651.40								648.60	REMOV INLETS
168 #	837+43	55 RT	651.35						648.59			REMOV INLETS
169 #	837+29	54 RT	651.79	648.09		648.09						REMOV MANHOLES
170	837+28	63 RT	651.55	644.45		644.45		644.42		644.45		CB ADJ NEW TIF CL
171	302+99	41 LT	652.88			--		647.87		--		MAN ADJUST
172	302+98	29 LT	652.12	647.12				647.12				REMOV INLETS
173	302+98	34 RT	652.49	647.49				647.49				REMOV INLETS
174	305+98	27 LT	654.54			647.89		647.89		647.89		MAN ADJUST
175	305+97	19 LT	653.81	648.06				648.06				REMOV CATCH BAS
176	305+98	19 RT	653.77	648.47				648.47				REMOV MANHOLES
177	841+81	89 LT	650.89	645.29				645.89				REMOV MANHOLES
178	842+96	88 LT	650.26	645.76				645.76				MH INFO ONLY
179	845+63	87 LT	651.11	645.06		--		644.91				CB INFO ONLY
180 #	845+60	38 LT	652.45								648.55	REMOV INLETS
181	846+80	86 LT	652.34	645.04		645.04		645.04				MH INFO ONLY
182	846+79	42 RT	N/A								648.14	REMOV EX FLAR END SEC
182A#	846+65	49 RT	649.14									REMOV CATCH BAS
183	847+01	87 LT	652.48	645.18		645.18		645.18				MH INFO ONLY
184	847+00	42 RT	N/A								648.15	REMOV EX FLAR END SEC
184A#	846+90	49 RT	649.44									REMOV CATCH BAS
185 #	848+35	59 LT	653.07			648.07					648.07	REMOV INLETS
186 #	848+33	46 LT	653.45								649.75	REMOV MANHOLES

* INDICATES EXISTING STRUCTURE TO BE REMOVED SHALL BE BACKFILLED WITH CLSM, SPECIAL

	USER NAME : mmaestra	DESIGNED REM	REVISED -
	PLOT SCALE : 1:2	DRAWN SAN	REVISED -
	PLOT DATE : 5/13/2017	CHECKED PJO	REVISED -
		DATE 05/12/17	REVISED -

**STATE OF ILLINOIS
DEPARTMENT OF TRANSPORTATION**

**EXISTING DRAINAGE
STRUCTURE SCHEDULE**

SCALE: AS SHOWN SHEET NO. 1 OF 3 SHEETS STA. TO STA.

F.A.I./P.R.T.E.	SECTION	COUNTY	TOTAL SHEETS	SHEET NO.
*	(99-1HB-1) R-1	WILL	1508	533
* FAI 55, FAP 856 ILLINOIS FED. AID PROJECT			CONTRACT NO. 60X10	

STRUCTURE NUMBER	LOCATION		RIM ELEVATION	INVERT								DESCRIPTION
	STATION	OFFSET		N	NE	E	SE	S	SW	W	NW	
187 #	850+86	77 LT	653.17	642.05				642.05				REMOV MANHOLES
188	853+50	76 LT	651.26	641.72		647.21	641.72					REMOV MANHOLES
189 #	853+50	40 LT	653.27							649.67		REMOV INLETS
191	841+62	64 RT	651.98		649.23							REMOV INLETS
192	841+66	70 RT	651.99	649.14						649.04		REMOV INLETS
193	842+41	68 RT	N/A				649.29					REMOV EX FLAR END SEC
194	842+16	64 RT	651.86	--								REMOV CATCH BAS
195	842+45	63 RT	N/A				649.32					REMOV EX FLAR END SEC
196 #	843+00	41 LT	651.69			649.24						REMOV INLETS
197 #	843+00	36 RT	651.78			648.48				648.48		REMOV INLETS
197A	843+00	42 RT	N/A							648.51		REMOV EX FLAR END SEC
198 #	845+59	32 RT	652.76			649.76						REMOV INLETS
199	845+59	42 RT	N/A							649.52		REMOV EX FLAR END SEC
200 #	848+29	30 RT	653.53			650.38						REMOV INLETS
201	848+29	46 RT	N/A							649.99		REMOV EX FLAR END SEC
202 #	853+49	49 RT	653.61			650.36						REMOV INLETS
203	853+48	61 RT	N/A							650.24		REMOV EX FLAR END SEC
204	855+92	65 RT	N/A							649.66		REMOV EX FLAR END SEC
205 #	855+91	44 LT	653.15			649.35				648.15		REMOV MANHOLES
206	855+92	80 LT	N/A			646.83						REMOV EX FLAR END SEC
207	855+98	64 RT	N/A							649.64		REMOV EX FLAR END SEC
208 #	855+98	58 RT	652.60	--		649.45				649.45		REMOV MANHOLES
209 #	856+71	75 RT	653.02	--			649.72			649.77		REMOV INLETS
210 #	856+78	45 RT	653.16			650.51						REMOV INLETS
211	857+71	87 RT	653.22	--			649.52	650.22		649.82		REMOV INLETS
211A	858+21	96 RT	656.21	650.21			650.21					REMOV MANHOLES
211B	503+86	18 LT	653.93			650.87						REMOV INLETS
212 #	857+79	73 RT	653.38				650.38					REMOV INLETS
213 #	857+54	57 RT	653.40		650.55							REMOV INLETS
214 #	855+99	37 RT	653.11			649.51				649.71		REMOV MANHOLES
215 #	856+00	17 LT	653.11			649.66				649.61		REMOV MANHOLES
216 #	856+02	24 LT	652.99	649.69		649.69				649.69		REMOV MANHOLES
217 #	857+83	22 LT	653.75		650.25			650.25				REMOV MANHOLES
218 #	857+92	16 LT	653.81			650.71		650.50		650.48		REMOV MANHOLES
219 #	858+07	54 LT	652.98			650.78						REMOV INLETS
220 #	857+91	40 RT	653.72				650.22		650.22			REMOV MANHOLES
221 #	857+58	43 RT	653.52	651.52								REMOV MANHOLES
222 #	856+00	38 LT	652.58			649.23				649.23		REMOV INLETS
223 #	856+00	45 LT	653.17			648.17				648.07		REMOV MANHOLES
224	856+00	80 LT	N/A			646.75						REMOV EX FLAR END SEC
225	856+31	101 LT	N/A	646.11								REMOV EX FLAR END SEC
226	857+01	103 LT	652.19	--			647.19					REMOV INLETS
227	857+70	105 LT	652.20				649.30					REMOV INLETS
228 #	860+54	44 RT	654.54					--				REMOV INLETS
229 #	860+50	41 RT	654.62		--					--		REMOV MANHOLES
230 #	860+50	14 LT	654.64			--				--		REMOV MANHOLES
231 #	860+50	57 LT	654.60	650.10		650.10						REMOV MANHOLES
231A#	860+50	50 LT	654.00			650.65				650.65		REMOV INLETS
232	862+16	54 LT	654.21	--			643.31			643.31		MAN ADJUST
234 #	863+07	37 LT	655.05					652.25				REMOV INLETS
235 #	863+00	24 LT	655.44			651.74				651.74		REMOV MANHOLES

STRUCTURE NUMBER	LOCATION		RIM ELEVATION	INVERT								DESCRIPTION
	STATION	OFFSET		N	NE	E	SE	S	SW	W	NW	
236 #	863+00	16 LT	655.48			652.18				652.18		REMOV MANHOLES
237 #	863+00	38 RT	655.39							652.49		REMOV INLETS
238 #	865+63	41 LT	653.89		651.29					650.99		REMOV MANHOLES
239 #	865+73	34 LT	656.22			653.02				652.82		REMOV INLETS
240 #	865+73	35 RT	656.55							653.85		REMOV INLETS
241	796+56	57 LT	N/A	628.11								REMOV EX FLAR END SEC
242	796+93	58 LT	N/A						628.94			REMOV EX FLAR END SEC
243	102+54	35 LT	636.33			634.02						REMOV INLETS
244	102+58	35 LT	636.24	634.22						633.74		REMOV INLETS
245	106+00	34 RT	635.23			631.96						REMOV INLETS
246	106+24	34 RT	635.30		--	--				631.46		REMOV INLETS
247	106+49	19 RT	635.40						632.92			REMOV CATCH BAS
248	107+19	45 RT	636.27	--		--				630.99		REMOV MANHOLES
249	107+24	18 RT	635.43						629.93			REMOV CATCH BAS
250	106+60	4 RT	635.37			631.45						REMOV INLETS
251	106+97	5 RT	635.32	631.27		631.27				631.27		REMOV CATCH BAS
252	106+49	35 LT	634.71			631.37						REMOV INLETS
253	106+74	34 LT	634.70			631.20				631.26		REMOV INLETS
254	106+99	34 LT	634.77			--	--	--	--	--		REMOV INLETS
255	107+48	35 LT	635.05				630.83		631.05	631.05		REMOV CATCH BAS
256	107+24	4 RT	635.29			630.99				630.99		REMOV INLETS
257	107+49	4 RT	635.56	630.56		630.51				630.56		REMOV CATCH BAS
258	91+98	35 RT	N/A	632.46								REM EXIST STRUCT N1
259	91+98	31 LT	N/A				632.89					REM EXIST STRUCT N1
260	7993+67	77 RT	N/A	639.65								REM EXIST STRUCT N2
261	7993+82	10 LT	N/A				640.41					REM EXIST STRUCT N2
262	828+04	66 RT	656.34	642.36			642.24		--			MAN ADJUST
263	830+91	66 RT	655.14	--			--			--		MAN ADJUST
264	832+65	65 RT	654.55	--			--		--	--		CB ADJ NEW TIF CL
265	835+05	66 RT	654.46	644.04			644.04		--			MAN ADJUST
266	836+88	63 RT	651.75	644.30			644.30					CB ADJ NEW TIF CL
267	839+16	65 RT	--		--		645.40					MAN ADJUST
268	201+34	106 LT	N/A						648.72			FES INFO ONLY
269	101+80	103 LT	641.07			637.41						INLET INFO ONLY
270	102+57	71 LT	639.15			634.25		--		--		CB ADJUST
271	104+10	53 LT	637.57		--	633.57				633.59		MAN ADJUST
272	105+65	53 LT	637.26			632.66				632.71	633.71	MAN ADJUST
272A	105+54	98 LT	638.32				633.44					CB INFO ONLY
273	107+63	62 LT	N/A			630.90						FES INFO ONLY
274	107+83	97 LT	N/A						630.53			FES INFO ONLY
275	107+86	72 LT	635.19	629.99			629.99		630.09			MH INFO ONLY
276	108+00	4 RT	636.09	630.24			630.24		630.34			CB ADJ NEW TIF CL
277	201+23	40 RT	658.06			656.31						CB ADJ NEW TIF CL
278	203+77	42 RT	654.77	--			--		--	--		CB INFO ONLY
279	203+78	22 RT	655.95	650.05		649.15		650.02				INLET INFO ONLY
280	203+87	21 RT	655.93						650.22			INLET INFO ONLY
281	203+81	19 LT	655.82	649.00		--	--					CB ADJUST
282	203+86	20 LT	655.82						650.31			CB ADJUST
283	203+83	26 LT	656.43			649.59		649.24		648.65		MAN ADJUST
284	203+50	85 LT	N/A				648.79					FES INFO ONLY
285	205+47	27 LT	657.92			651.65		651.61		651.65		MAN ADJUST

* INDICATES EXISTING STRUCTURE TO BE REMOVED SHALL BE BACKFILLED WITH CLSM, SPECIAL

FILE NAME : D:\60X10-shr-drain02-Existing Structure Schedule-02.dgn



USER NAME : mmaestra	DESIGNED REM	REVISED -
	DRAWN SAN	REVISED -
PLOT SCALE : 1:2	CHECKED PJO	REVISED -
PLOT DATE : 5/13/2017	DATE 05/12/17	REVISED -

**STATE OF ILLINOIS
DEPARTMENT OF TRANSPORTATION**

**EXISTING DRAINAGE
STRUCTURE SCHEDULE**

SCALE: AS SHOWN SHEET NO. 2 OF 3 SHEETS STA. TO STA.

F.A.I./P RTE.	SECTION	COUNTY	TOTAL SHEETS	SHEET NO.
*	(99-1HB-1) R-1	WILL	1508	534
CONTRACT NO. 60X10				
* FAI 55, FAP 856 ILLINOIS FED. AID PROJECT				

STRUCTURE NUMBER	LOCATION		RIM ELEVATION	INVERT								DESCRIPTION
	STATION	OFFSET		N	NE	E	SE	S	SW	W	NW	
286	205+49	19 LT	656.50	650.80				650.45				INLET INFO ONLY
287	95+28	33 LT	641.56					--				REMOV INLETS
288	95+30	35 RT	641.51	637.91						637.91		REMOV INLETS
289	93+78	26 LT	640.39					--				REMOV INLETS
290	93+76	28 RT	640.11	636.96		636.96				636.96		REMOV INLETS
291	93+18	25 RT	639.93			636.33				636.33		REMOV INLETS
292	93+03	24 LT	640.01			636.45		636.41				REMOV INLETS
292A	93+19	25 LT	640.03							637.34		REMOV INLETS
293	93+02	24 RT	640.07	636.52		636.42				636.37		REMOV INLETS
294	92+27	21 RT	640.39			634.39			635.79			REMOV INLETS
295	92+17	36 RT	N/A		634.48							REMOV EX FLAR END SEC
296	91+76	20 LT	641.00						637.90			REMOV INLETS
297	91+71	20 RT	641.18	635.98			635.98					REMOV INLETS
298	91+79	34 RT	N/A								634.94	REMOV EX FLAR END SEC
299	108+49	4 RT	636.21					632.46				REMOV CATCH BAS
300	108+49	13 RT	636.21	632.46				632.46				REMOV CATCH BAS
301	108+50	52 RT	634.73	630.93		630.93				630.93		MAN ADJUST
302	496+71	33 RT	651.86			647.66						INLETS ADJUST
303	497+12	37 RT	652.73				643.13			--	638.98	REMOV MANHOLES
304	496+70	32 LT	651.81						646.30			INLETS ADJUST
305	496+35	3 LT	653.32		646.12		638.12			642.82		REMOV MANHOLES
306	6009+15	77 RT	648.88				--		645.63			MAN ADJUST
307	6006+11	74 LT	646.72		644.47				644.47			MAN RECONST
308	809+06	115 RT	649.76		--				--			MAN ADJUST
309	807+70	161 LT	647.00			642.14			642.10			MAN ADJUST
310	7997+11	10 LT	651.08		--				--			MAN ADJUST
311	7995+87	100 RT	643.61		641.01					641.01		MAN ADJUST
312	396+66	19 LT	648.76	644.91				644.91				CB ADJUST
313	4994+05	34 LT	N/A	651.85								REMOV EX FLAR END SEC
314	4993+92	60 RT	N/A					653.03				CONC HDWL REM
315	6006+97	85 RT	N/A								647.73	CONC HDWL REM
316	6006+86	40 RT	N/A				647.38					CONC HDWL REM
320	9011+10	32 RT	N/A				343.61					CONC HDWL REM SPL
320A	9011+06	31 RT	N/A									BOX CULV INFO ONLY
321	9011+07	53 LT	N/A								643.22	CONC HDWL REM SPL
322	3099+10	76 LT	N/A				643.20					CONC HDWL REM
323	3099+10	77 RT	N/A									CONC HDWL REM
324	3099+22	74 LT	N/A				644.07					CONC HDWL REM SPL
324A	3099+22	74 LT	N/A									BOX CULV INFO ONLY
325	3099+22	74 RT	N/A								643.91	CONC HDWL REM SPL
360	111+26	34 RT	638.15			633.05				633.05		INLET INFO ONLY
361	112+00	35 RT	637.78			633.78				633.72		INLET INFO ONLY
370	871+40	32 LT	656.50	653.40		653.45						INLETS ADJUST
371	871+48	32 LT	656.54	653.39				653.59				MAN ADJUST
372	874+22	42 LT	655.96	653.06		652.06			645.91			MAN ADJUST
373	874+35	42 LT	655.43			651.93		651.88				MAN ADJUST

* INDICATES EXISTING STRUCTURE TO BE REMOVED SHALL BE BACKFILLED WITH CLSM, SPECIAL

EXISTING DRAINAGE STRUCTURE SCHEDULE SUMMARY			
PAY ITEM	PAY ITEM ABBREVIATION FROM SCHEDULE	TOTAL QUANTITY	UNITS
CONCRETE HEADWALL REMOVAL	CONC HDWL REM	10	EACH
*CATCH BASINS TO BE ADJUSTED	CB ADJUST	4	EACH
CATCH BASINS TO BE ADJUSTED WITH NEW TYPE 1 FRAME, CLOSED LID	CB ADJ NEW T1F CL	5	EACH
*MANHOLES TO BE ADJUSTED	MAN ADJUST	21	EACH
*MANHOLES TO BE RECONSTRUCTED	MAN RECONST	1	EACH
*INLETS TO BE ADJUSTED	INLETS ADJUST	3	EACH
REMOVING MANHOLES	REMOV MANHOLES	46	EACH
REMOVING CATCH BASINS	REMOV CATCH BAS	15	EACH
REMOVING INLETS	REMOV INLETS	89	EACH
REMOVE EXISTING FLARED END SECTION	REMOV EX FLAR END SEC	23	EACH
**PLUG PIPE PENETRATION	**PLUG PIPE PENETRATION	2	EACH
***CONCRETE HEADWALL REMOVAL SPECIAL	CONC HDWL REM SPL	4	EACH
CONTROLLED LOW-STRENGTH MATERIAL, SPECIAL	CONTR LOWSTR MATL SPL	1132	CU YD
SANITARY MANHOLES TO BE ADJUSTED	SANITARY MANHOLE ADJ	9	EACH

- *QUANTITY SHOWN FOR MANHOLES, CATCH BASINS, AND INLETS TO BE ADJUSTED DOES NOT INCLUDE STRUCTURES TO BE ADJUSTED FOR MOT PURPOSES. SEE MOT AND EROSION CONTROL PLANS FOR ADDITIONAL QUANTITIES.
- **THE ELEVATION OF THE DIRECT CONNECTION TO A PIPE SHALL BE FIELD VERIFIED PRIOR TO PERFORMING PLUG PIPE PENETRATION.
- ***SEE BOX CULVERT END SECTION DETAILS FOR ADDITIONAL DETAILS.

FILE NAME : D:\60X10-shr-drain\03-Existing Structure Schedule-03.dgn

	USER NAME : dbarnes	DESIGNED REM	REVISED -	STATE OF ILLINOIS DEPARTMENT OF TRANSPORTATION	EXISTING DRAINAGE STRUCTURE SCHEDULE	F.A.I./P RTE.	SECTION	COUNTY	TOTAL SHEETS	SHEET NO.
	PLOT SCALE : 1:2	DRAWN SAN	REVISED -			*	(99-1HB-1) R-1	WILL	1508	535
	PLOT DATE : 6/14/2017	CHECKED PJO	REVISED -			CONTRACT NO. 60X10				
DATE 06/16/17			REVISED -	SCALE: AS SHOWN SHEET NO. 3 OF 3 SHEETS STA. TO STA.		* FAI 55, FAP 856 ILLINOIS FED. AID PROJECT				

PIPE NUMBER	PIPE LENGTH (FOOT)	EXISTING STORM SEWER PIPE SCHEDULE	TRENCH BACKFILL	CONTR LOW-STRENGTH MATL SPL	STORM SEWER FILLED	COMMENTS
			(CU YD)	(CU YD)	(CU YD)	
101	295	STORM SEWER REM 24		91		
102	8	STORM SEWER REM 12		4		
103	166	STORM SEWER REM 12		82		
104	260	STORM SEWER REM 18		279		
105	15	STORM SEWER REM 12		7		
106	66	STORM SEWER REM 12		31		
107	235	STORM SEWER REM 15		241		
108	6	STORM SEWER REM 12		3		
109	86	STORM SEWER REM 12		32		
110	193	STORM SEWER REM 15		187		
111	215	STORM SEWER REM 15		187		
112	9	STORM SEWER REM 12		4		
113	68	STORM SEWER REM 12		17		
114	250	STORM SEWER REM 15		13		
115	8	STORM SEWER REM 12		4		
116	77	STORM SEWER REM 12		20		
117	87	STORM SEWER REM 12		24		
118	291	STORM SEWER REM 15		168		
119	8	STORM SEWER REM 12		4		
120	68	STORM SEWER REM 12		23		
121	219	STORM SEWER REM 12		194		
122	10	STORM SEWER REM 12		5		
123	67	STORM SEWER REM 12		21		
124	17	STORM SEWER REM 12		6		
127	635	STORM SEWER REM 24		912		
128	208	STORM SEWER REM 24	54			
129	65	STORM SEWER REM 24	32			
131	140	PIPE CULVERT REMOV	93			
131A	16	STORM SEWER REM 12	3			
131B	12	STORM SEWER REM 12	4			
131C	49	STORM SEWER REM 12	19			
131D	34	STORM SEWER REM 12	9			
131E	46	STORM SEWER REM 12	20			
131F	60	STORM SEWER REM 15	28			
132	196	SS CLEANED 24			23	TV INSPECT OF SEWER
134	188	SS CLEANED 36			50	TV INSPECT OF SEWER
136	72	STORM SEWER REM 12		18		
137	10	STORM SEWER REM 12		6		
138	243	STORM SEWER REM 12		203		
139	343	STORM SEWER REM 15		196		
140	9	STORM SEWER REM 12		5		
141	73	STORM SEWER REM 12		23		
142	224	STORM SEWER REM 18		123		
143	5	STORM SEWER REM 12		2		
144	84	STORM SEWER REM 12		22		
145	42	STORM SEWER REM 12		16		
146	88	STORM SEWER REM 18		31		

PIPE NUMBER	PIPE LENGTH (FOOT)	EXISTING STORM SEWER PIPE SCHEDULE	TRENCH BACKFILL	CONTR LOW-STRENGTH MATL SPL	STORM SEWER FILLED	COMMENTS
			(CU YD)	(CU YD)	(CU YD)	
147	9	STORM SEWER REM 12		4		
148	314	STORM SEWER REM 18		169		
149	8	STORM SEWER REM 12		3		
150	352	SS CLEANED 48				TV INSPECT OF SEWER & REM 21'
151	211	STORM SEWER REM 18		115		
152	7	STORM SEWER REM 12		3		
153	67	STORM SEWER REM 12		28		
154	27	STORM SEWER REM 24		20		
155	18	STORM SEWER REM 12		15		
156	66	STORM SEWER REM 12		25		
157	80	STORM SEWER REM 12		25		
158	28	STORM SEWER REM 12		9		
159	104	STORM SEWER REM 12		24		
160	22	STORM SEWER REM 12		6		
161	95	STORM SEWER REM 12		34		
162	14	STORM SEWER REM 15		4		
162A	7	STORM SEWER REM 12		2		
163	13	STORM SEWER REM 24	3			
164	82	STORM SEWER REM 24	39			
165	8	STORM SEWER REM 12	2			
166	11	STORM SEWER REM 24	6			
166A	323	SS CLEANED 36				TV INSPECT OF SEWER
167	8	STORM SEWER REM 12	2			
168	14	STORM SEWER REM 12		2		
169	9	STORM SEWER REM 12		4		
170	40	SS CLEANED 48				TV INSPECT OF SEWER
171	238	SS CLEANED 42				TV INSPECT OF SEWER & REM 14'
172		INFO ONLY: 12 FT OF 27" SS				
173		INFO ONLY: 63 FT OF 27" SS				
174	304	SS CLEANED 36				TV INSPECT OF SEWER
174A	156	SS CLEANED 30				
175	9	STORM SEWER REM 24				
176		INFO ONLY: 37 FT OF 24" SS				
176A	7	STORM SEWER REM 24				
177	115	SS CLEANED 27			17	TV INSPECT OF SEWER
177A	403	STORM SEWER REM 12				
178	266	SS CLEANED 27			33	TV INSPECT OF SEWER
179	117	SS CLEANED 27			17	TV INSPECT OF SEWER
180	49	STORM SEWER REM 12	17			
181	21	SS CLEANED 60			15	TV INSPECT OF SEWER
182	128	STORM SEWER REM 42		228		
183	357	STORM SEWER REM 60	693			SEE NOTE 2
184	130	STORM SEWER REM 42		138		
185	24	STORM SEWER REM 12		12		
186	14	STORM SEWER REM 12		5		
187	264	STORM SEWER REM 60	689			SEE NOTE 2
188	185	STORM SEWER REM 60	434			SEE NOTE 2

FILE NAME = D:\60X10-shr-drain04-Existing Pipe Schedule-01.dgn

KNIGHT Engineers & Architects	USER NAME = mmaestra	DESIGNED REM	REVISED -
	PLOT SCALE = 1:2	DRAWN SAN	REVISED -
	PLOT DATE = 5/13/2017	CHECKED PJO	REVISED -
		DATE 05/12/17	REVISED -

**STATE OF ILLINOIS
DEPARTMENT OF TRANSPORTATION**

EXISTING DRAINAGE PIPE SCHEDULE		F.A.I./P RTE.	SECTION	COUNTY	TOTAL SHEETS	SHEET NO.
SCALE: AS SHOWN		*	(99-1HB-1) R-1	WILL	1508	536
SHEET NO. 1 OF 3 SHEETS		STA.		TO STA.		CONTRACT NO. 60X10
* FAI 55, FAP 856 [ILLINOIS] FED. AID PROJECT						

PIPE NUMBER	PIPE LENGTH (FOOT)	EXISTING STORM SEWER PIPE SCHEDULE	TRENCH BACKFILL	CONTR. LOW-STRENGTH MATL SPL	STORM SEWER FILLED	COMMENTS
			(CU YD)	(CU YD)	(CU YD)	
189	36	STORM SEWER REM 12	12			
191	8	STORM SEWER REM 12	2			
192	77	STORM SEWER REM 24	15			
194	31	STORM SEWER REM 12	2			
196	78	STORM SEWER REM 12		16		
197	8	STORM SEWER REM 12		3		
198	12	STORM SEWER REM 12		4		
200	16	STORM SEWER REM 12		5		
202	13	STORM SEWER REM 12		4		
204	109	STORM SEWER REM 24		45		
205	34	STORM SEWER REM 24	35			
207	8	STORM SEWER REM 24		3		
208	21	STORM SEWER REM 24		9		
209	75	STORM SEWER REM 12		23		
210	31	STORM SEWER REM 12		7		
211	100	STORM SEWER REM 12		34		
211A	52	STORM SEWER REM 15				
211B	20	STORM SEWER REM 12	5			
212	16	STORM SEWER REM 12		5		
213	34	STORM SEWER REM 12		9		
214	54	STORM SEWER REM 24		21		
215	7	STORM SEWER REM 24		3		
216	15	STORM SEWER REM 24		6		
217	182	STORM SEWER REM 15		59		
218	11	STORM SEWER REM 12		4		
219	41	STORM SEWER REM 12		8		
220	56	STORM SEWER REM 12		15		
221	34	STORM SEWER REM 12		6		
222	6	STORM SEWER REM 24		4		
223	35	STORM SEWER REM 24	42			
226	65	STORM SEWER REM 12	5			
227	69	STORM SEWER REM 12	17			
228	5	STORM SEWER REM 12		2		
229	55	STORM SEWER REM 12		22		
230	36	STORM SEWER REM 12		15		
231	167	STORM SEWER REM 24		315		
231A	6	STORM SEWER REM 12		2		
233	68	STORM SEWER REM 15	33			
234	26	STORM SEWER REM 12	6			
235	38	STORM SEWER REM 15		13		
236	8	STORM SEWER REM 12		3		
237	55	STORM SEWER REM 12		14		
238	20	STORM SEWER REM 12	5			
239	12	STORM SEWER REM 12	4			
240	69	STORM SEWER REM 12		19		
242	38	STORM SEWER REM 24	13			
243	4	STORM SEWER REM 12	1			

PIPE NUMBER	PIPE LENGTH (FOOT)	EXISTING STORM SEWER PIPE SCHEDULE	TRENCH BACKFILL	CONTR. LOW-STRENGTH MATL SPL	STORM SEWER FILLED	COMMENTS
			(CU YD)	(CU YD)	(CU YD)	
244	36	STORM SEWER REM 15				
245	25	STORM SEWER REM 12	9			
246	96	STORM SEWER REM 12	38			
247	29	STORM SEWER REM 12	10			
248	92	STORM SEWER REM 12	15			
249	28	STORM SEWER REM 12	15			
250	37	STORM SEWER REM 12	13			
251	27	STORM SEWER REM 12	10			
252	25	STORM SEWER REM 12	7			
253	24	STORM SEWER REM 12	8			
254A	39	STORM SEWER REM 12	12			
254B	49	STORM SEWER REM 18	19			
255	39	STORM SEWER REM 18	19			
256	25	STORM SEWER REM 12	12			
257	51	SS CLEANED 24				
262	394	SS CLEANED 48				TV INSPECT OF SEWER
263	286	SS CLEANED 48				TV INSPECT OF SEWER
264	175	SS CLEANED 48				TV INSPECT OF SEWER
265	240	SS CLEANED 48				TV INSPECT OF SEWER
266	183	SS CLEANED 48				TV INSPECT OF SEWER
267	188	SS CLEANED 48				TV INSPECT OF SEWER
267A		INFO ONLY: 55 FT OF 48" SS				
268	0	INFO ONLY: 90 FT OF 12" SS				
269		INFO ONLY: 83 FT OF 12" SS				
270		INFO ONLY: 154 FT OF 18" SS				
271		INFO ONLY: 154 FT OF 24" SS				
271A		INFO ONLY: 76 FT OF 12" SS				
272	182	STORM SEWER REM 24	35			
272A	46	INFO ONLY: 46 FT OF 12" SS				
273	20	SS CLEANED 24				
274		INFO ONLY: 22 FT OF 36" SS				
275	78	SS CLEANED 36				
276	65	SS CLEANED 36				
277		INFO ONLY: 252 FT OF 12" SS				
278		INFO ONLY: 19 FT OF 24" SS				
278A		INFO ONLY: 23 FT OF 24" SS				
279		INFO ONLY: 40 FT OF 30" SS				
280		INFO ONLY: 9 FT OF 12" SS				
281		INFO ONLY: 7 FT OF 30" SS				
282		INFO ONLY: 5 FT OF 12" SS				
283		INFO ONLY: 68 FT OF 48" SS				
285		INFO ONLY: 163 FT OF 48" SS				
285A		INFO ONLY: 51 FT OF 42" SS				
286		INFO ONLY: 8 FT OF 24" SS				
286A		INFO ONLY: 41 FT OF 24" SS				
287	68	STORM SEWER REM 12	22			

FILE NAME = D:\60X10-shr-drain05-Existing_Pipe_Schedule-02.dgn



USER NAME = mmaestra	DESIGNED REM	REVISED -
PLOT SCALE = 1:2	DRAWN SAN	REVISED -
PLOT DATE = 5/13/2017	CHECKED PJO	REVISED -
	DATE 05/12/17	REVISED -

**STATE OF ILLINOIS
DEPARTMENT OF TRANSPORTATION**

EXISTING DRAINAGE PIPE SCHEDULE	
SCALE: AS SHOWN	SHEET NO. 2 OF 3 SHEETS
STA.	TO STA.

F.A.I./P RTE.	SECTION	COUNTY	TOTAL SHEETS	SHEET NO.
*	(99-1HB-1) R-1	WILL	1508	537
* FAI 55, FAP 856 [ILLINOIS] FED. AID PROJECT			CONTRACT NO. 60X10	

PIPE NUMBER	PIPE LENGTH (FOOT)	EXISTING STORM SEWER PIPE SCHEDULE	TRENCH BACKFILL	CONTR LOW-STRENGTH MATL SPL	STORM SEWER FILLED	COMMENTS
			(CU YD)	(CU YD)	(CU YD)	
288	154	STORM SEWER REM 12	46			
289	54	STORM SEWER REM 12	19			
290	57	STORM SEWER REM 12	16			
291	16	STORM SEWER REM 12	5			
292	49	STORM SEWER REM 12	16			
292A	15	STORM SEWER REM 12	3			
293	75	STORM SEWER REM 12	25			
294	18	STORM SEWER REM 12	8			
296	40	STORM SEWER REM 12	11			
297	17	STORM SEWER REM 12	8			
299	8	STORM SEWER REM 12	3			
300	40	STORM SEWER REM 12	3			
302	6	STORM SEWER REM 12	14			
303	86	SS CLEANED 54			72	TV INSPECT OF SEWER
304	6	STORM SEWER REM 12				REM 6' FOR MH INSTALLATION
305	7	STORM SEWER REM 54				REM 7' FOR MH INSTALLATION
305A	7	STORM SEWER REM 54				REM 7' FOR MH INSTALLATION
306	340	SS CLEANED 12				TV INSPECT OF SEWER
307	340	SS CLEANED 12				TV INSPECT OF SEWER
308	307	SS CLEANED 12				TV INSPECT OF SEWER
309	160	SS CLEANED 12				TV INSPECT OF SEWER
310	166	SS CLEANED 12				TV INSPECT OF SEWER
311	178	SS CLEANED 12				TV INSPECT OF SEWER
313	96	PIPE CULVERT REMOV	35			
315	46	PIPE CULVERT REMOV				
320A	68	BOX CUL TO BE CLEANED				EXIST 5' X 3'
322	5	PIPE CULVERT REMOV				
322A	153	SS CLEANED 36				
323	4	PIPE CULVERT REMOV				
324A	148	BOX CUL TO BE CLEANED				EXIST 2 - 4' X 2'

EXISTING STORM SEWER SCHEDULE SUMMARY			
PAY ITEM	PAY ITEM ABBREVIATION FROM SCHEDULE	TOTAL QUANTITY	UNITS
TRENCH BACKFILL	TRENCH BACKFILL	2800	CU YD
PIPE CULVERT REMOVAL	PIPE CULVERT REMOV	291	FOOT
STORM SEWER REMOVAL 12"	STORM SEWER REM 12	4840	FOOT
STORM SEWER REMOVAL 15"	STORM SEWER REM 15	1977	FOOT
STORM SEWER REMOVAL 18"	STORM SEWER REM 18	1185	FOOT
STORM SEWER REMOVAL 24"	STORM SEWER REM 24	1984	FOOT
STORM SEWER REMOVAL 36"	STORM SEWER REM 36	40	FOOT
STORM SEWER REMOVAL 42"	STORM SEWER REM 42	312	FOOT
STORM SEWER REMOVAL 48"	STORM SEWER REM 48	21	FOOT
STORM SEWER REMOVAL 54"	STORM SEWER REM 54	28	FOOT
STORM SEWER REMOVAL 60"	STORM SEWER REM 60	806	FOOT
STORM SEWER TO BE FILLED	STORM SEWER FILLED	227	CU YD
TELEVISION INSPECTION OF SEWER	TV INSPECT OF SEWER	5203	FOOT
STORM SEWERS TO BE CLEANED 12"	SS CLEANED 12	1491	FOOT
STORM SEWERS TO BE CLEANED 24"	SS CLEANED 24	267	FOOT
STORM SEWERS TO BE CLEANED 27"	SS CLEANED 27	498	FOOT
STORM SEWERS TO BE CLEANED 30"	SS CLEANED 30	156	FOOT
STORM SEWERS TO BE CLEANED 36"	SS CLEANED 36	1111	FOOT
STORM SEWERS TO BE CLEANED 42"	SS CLEANED 42	238	FOOT
STORM SEWERS TO BE CLEANED 48"	SS CLEANED 48	1858	FOOT
STORM SEWERS TO BE CLEANED 54"	SS CLEANED 54	86	FOOT
STORM SEWERS TO BE CLEANED 60"	SS CLEANED 60	21	FOOT
CONTROLLED LOW-STRENGTH MATERIAL, SPECIAL	CONTR LOWSTR MATL SPL	4777	CU YD
BOX CULVERT TO BE CLEANED	BOX CUL TO BE CLEANED	216	FOOT

- *STORM SEWER REM 24 EQRS SHALL BE PAID FOR AS STORM SEWER REMOVAL 24"
- **STORM SEWER REM 42 EQRS SHALL BE PAID FOR AS STORM SEWER REMOVAL 42"
- * ALL PIPES TO BE REMOVED THAT ARE 12" DIAMETER OR SMALLER SHALL BE PAID FOR AT THE CONTRACT UNIT PRICE OF STORM SEWER REMOVAL 12".

NOTES

1. QUANTITY PROVIDED FOR POSSIBLE LIGHTING CONFLICT WITH EXISTING STORM SEWER. SEE EXISTING DRAINAGE PLANS.
2. THE EXISTING PIPES TO BE REMOVED ARE SUBMERGED AND THE SIZE COULD NOT BE VERIFIED THROUGH SURVEY. THE SURVEY ESTIMATED THE PIPES TO BE 60 INCH DIAMETER CONCRETE PIPES. THE REMOVAL OF THESE PIPES SHALL BE PAID FOR AS STORM SEWER REMOVAL 60" REGARDLESS OF THE PIPE SIZE FOUND IN THE FIELD.

FILE NAME : D:\60X10-shr-drain06-Existing Pipe Schedule-03.dgn

	USER NAME : dbarnes	DESIGNED REM	REVISED -	STATE OF ILLINOIS DEPARTMENT OF TRANSPORTATION	EXISTING DRAINAGE PIPE SCHEDULE	F.A.I./P RTE.	SECTION	COUNTY	TOTAL SHEETS	SHEET NO.
	PLOT SCALE : 1:2	DRAWN SAN	REVISED -			*	(99-1HB-1) R-1	WILL	1508	538
	PLOT DATE : 6/14/2017	CHECKED PJO	REVISED -			CONTRACT NO. 60X10				
				SCALE: AS SHOWN SHEET NO. 3 OF 3 SHEETS STA. TO STA.		* FAI 55, FAP 856 ILLINOIS FED. AID PROJECT				

BEGIN IMPROVEMENT
CONTRACT 60X10
STA. 790+20

COORDINATE WITH
CONTRACT 61D47

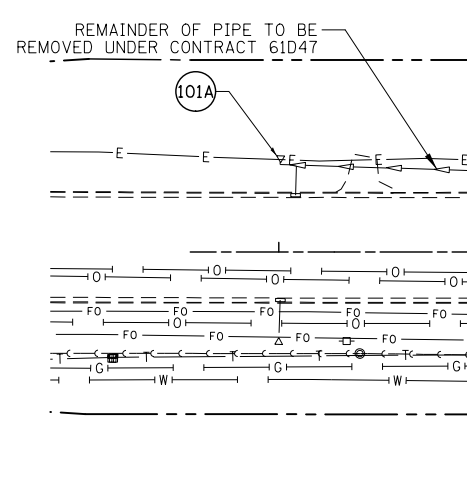
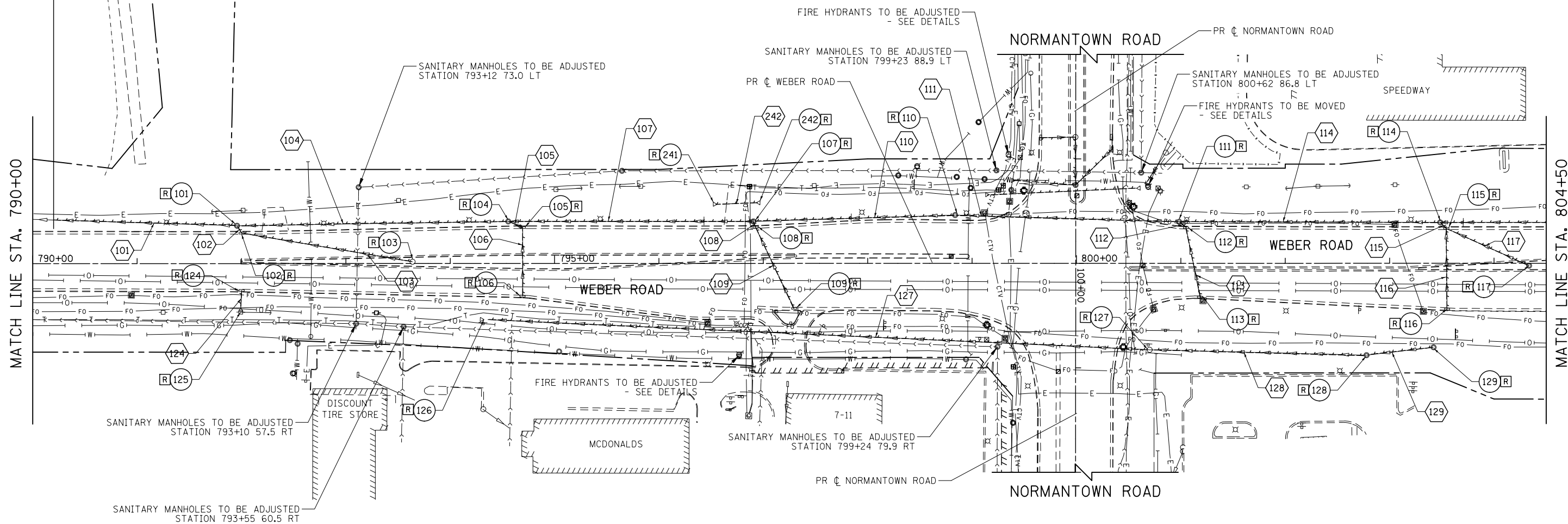

EXISTING DRAINAGE LEGEND

- DRAINAGE STRUCTURE TO BE REMOVED R
- DRAINAGE STRUCTURE TO BE ADJUSTED A
- DRAINAGE STRUCTURE TO BE CLEANED C
- DRAINAGE PIPE TO BE TELEVISED T
- DRAINAGE PIPE TO BE FILLED F
- DRAINAGE PIPE REMOVAL XXX
- EXISTING DRAINAGE STRUCTURE (SEE DRAINAGE SCHEDULES) XXX
- EXISTING DRAINAGE PIPE (SEE DRAINAGE SCHEDULES) XXX
- EXISTING MANHOLE O
- EXISTING CATCH BASIN I
- EXISTING INLET I
- EXISTING STORM SEWER —

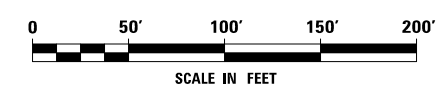
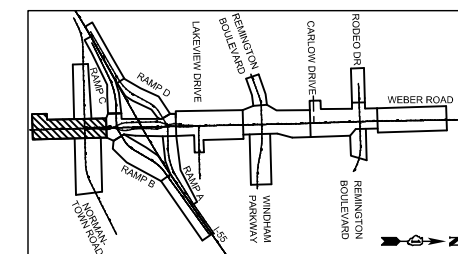

FILE NAME = D:\60X10-shr-draw\01-ex-draw\weber.dgn



USER NAME = mmaestra	DESIGNED REM	REVISED -
DRAWN SAN	REVISOR -	
PLOT SCALE = 1:1000	CHECKED PJO	REVISED -
PLOT DATE = 5/13/2017	DATE 05/12/17	REVISED -

**STATE OF ILLINOIS
DEPARTMENT OF TRANSPORTATION**

EXISTING DRAINAGE PLAN - WEBER ROAD

SCALE: AS SHOWN SHEET NO. 1 OF 17 SHEETS STA. TO STA.

F.A.I./P RTE.	SECTION	COUNTY	TOTAL SHEETS	SHEET NO.
*	(99-1HB-1) R-1	WILL	1508	539
CONTRACT NO. 60X10				
* FAI 55, FAP 856 [ILLINOIS] FED. AID PROJECT				

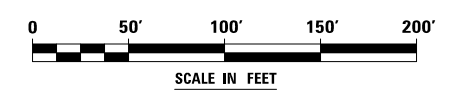
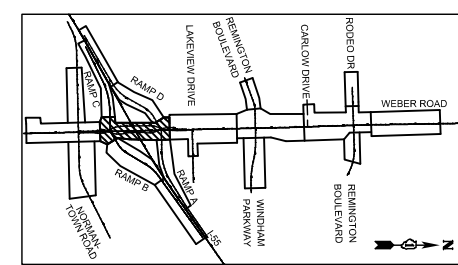
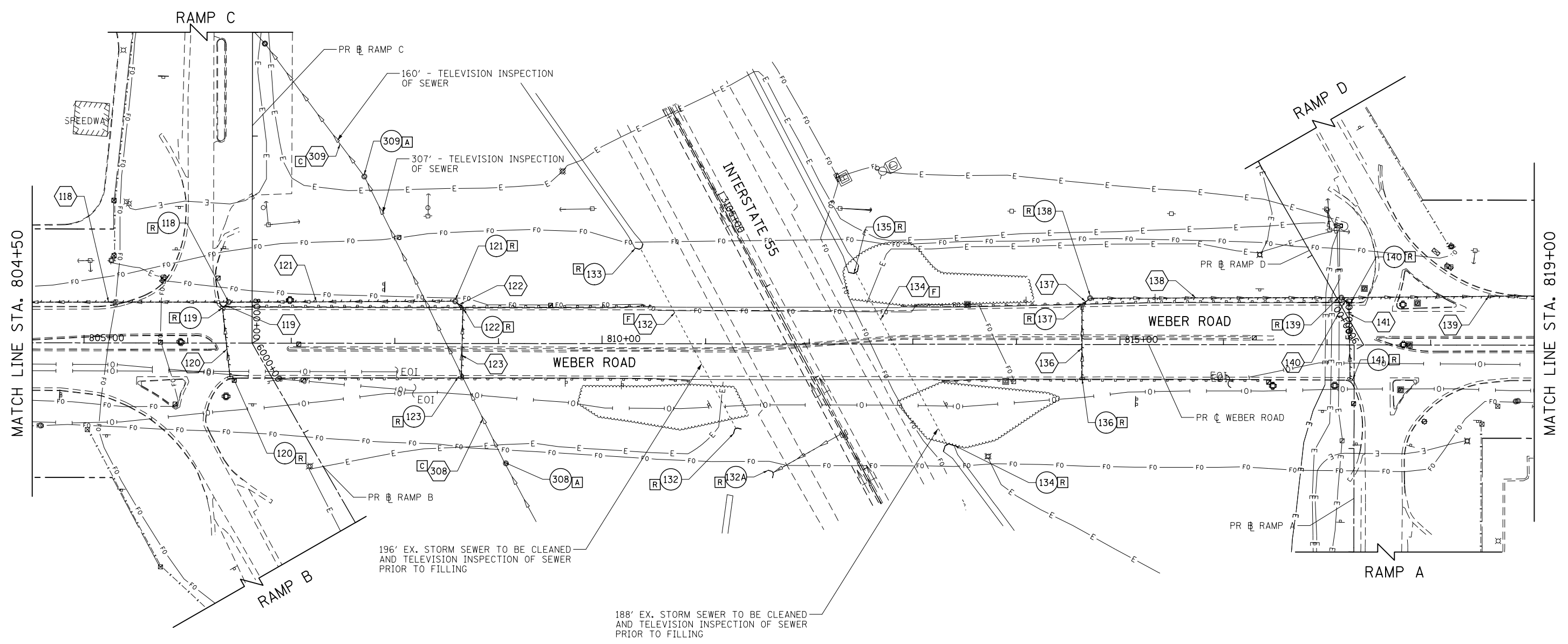
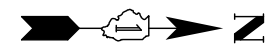

FILE NAME : D:\60X10-shr-drain02-exdrain-Weber.dgn

KNIGHT
Engineers & Architects

USER NAME = mmaestra	DESIGNED REM	REVISED -
PLOT SCALE = 1:1000	DRAWN SAN	REVISED -
PLOT DATE = 5/13/2017	CHECKED PJO	REVISED -
	DATE 05/12/17	REVISED -

STATE OF ILLINOIS
DEPARTMENT OF TRANSPORTATION

EXISTING DRAINAGE PLAN - WEBER ROAD

SCALE: AS SHOWN SHEET NO. 2 OF 17 SHEETS STA. TO STA.

F.A./P RTE.	SECTION	COUNTY	TOTAL SHEETS	SHEET NO.
*	(99-1HB-1) R-1	WILL	1508	540
CONTRACT NO. 60X10				
* FAI 55, FAP 856 ILLINOIS FED. AID PROJECT				

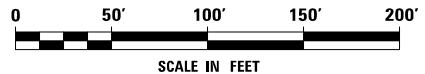
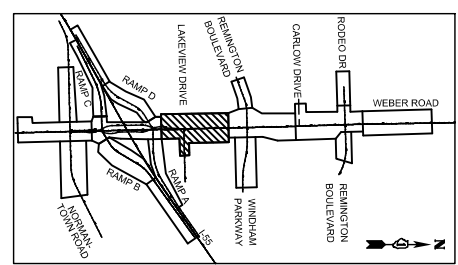
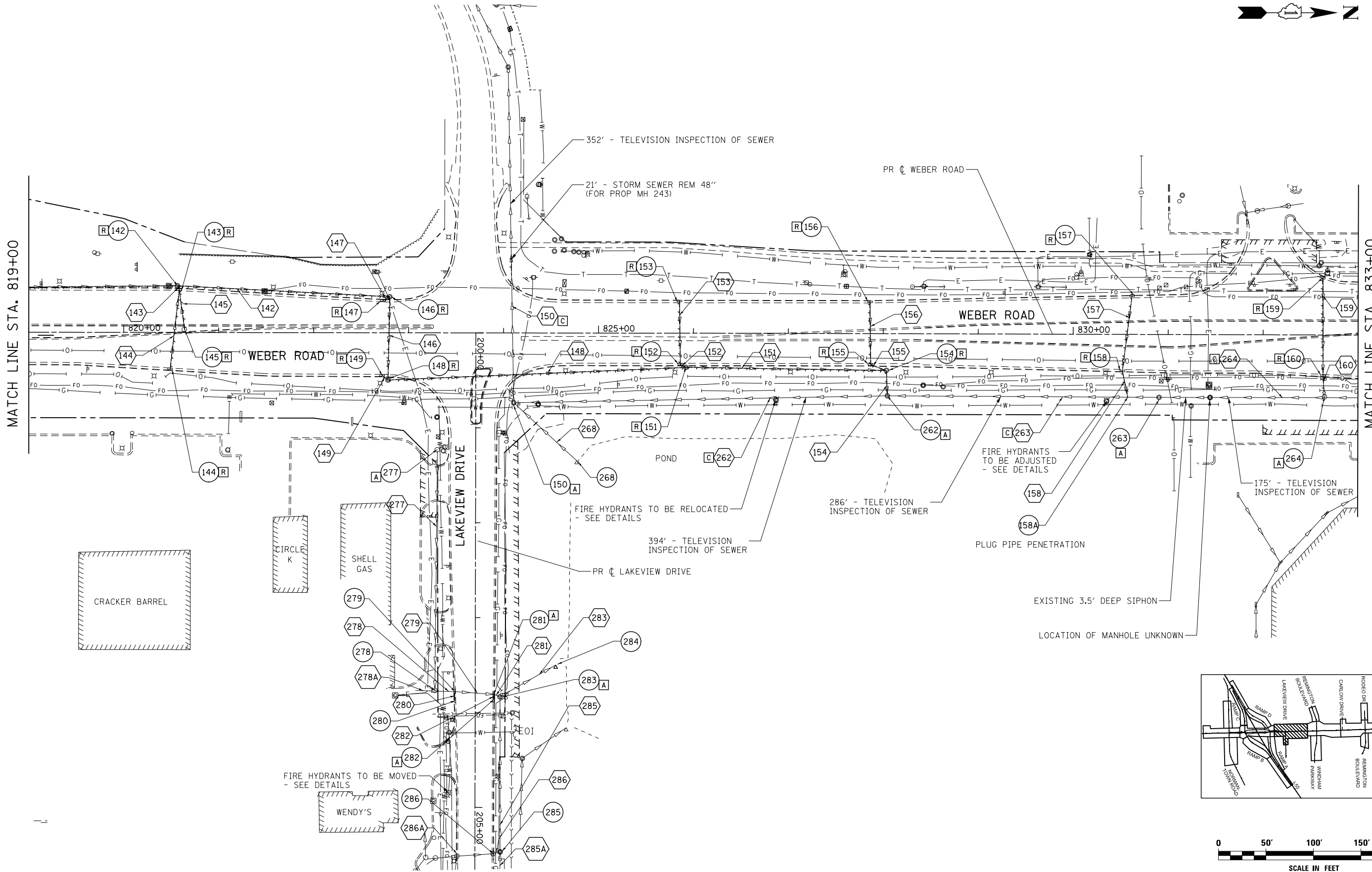

FILE NAME : D:\60X10-shr-draw\03-exdr-am-weber.dgn

KNIGHT
Engineers & Architects

USER NAME = mmaestra	DESIGNED REM	REVISED -
DRAWN SAN	REVISIONS	REVISED -
PLOT SCALE = 1:1000	CHECKED PJO	REVISED -
PLOT DATE = 5/13/2017	DATE 05/12/17	REVISED -

**STATE OF ILLINOIS
DEPARTMENT OF TRANSPORTATION**

EXISTING DRAINAGE PLAN - WEBER ROAD
SCALE: AS SHOWN SHEET NO. 3 OF 17 SHEETS STA. TO STA.

F.A.I./P RTE.	SECTION	COUNTY	TOTAL SHEETS	SHEET NO.
*	(99-1HB-1) R-1	WILL	1508	541
CONTRACT NO. 60X10				
* FAI 55, FAP 856 [ILLINOIS] FED. AID PROJECT				

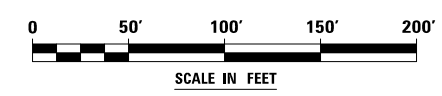
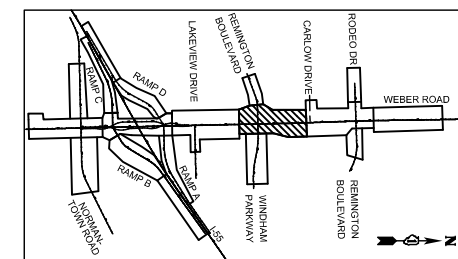
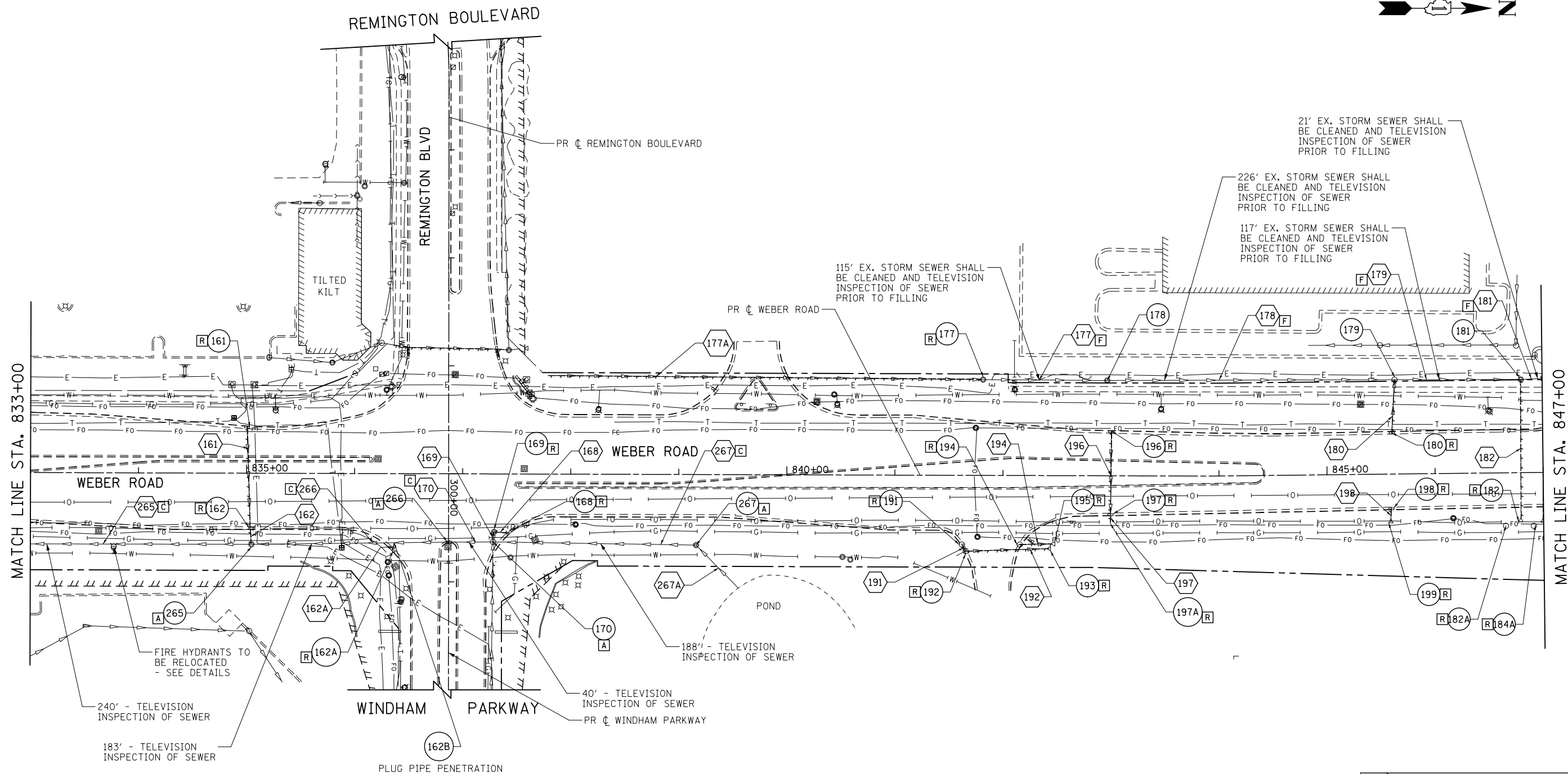

FILE NAME : D:\60X10-shr-draw\04-ex-drain-Weber.dgn

KNIGHT
Engineers & Architects

USER NAME = mmaestra	DESIGNED REM	REVISED -
PLOT SCALE = 1:100	DRAWN SAN	REVISED -
PLOT DATE = 5/13/2017	CHECKED PJO	REVISED -
	DATE 05/12/17	REVISED -

**STATE OF ILLINOIS
DEPARTMENT OF TRANSPORTATION**

EXISTING DRAINAGE PLAN - WEBER ROAD

SCALE: AS SHOWN SHEET NO. 4 OF 17 SHEETS STA. TO STA.

F.A.I./P RTE.	SECTION	COUNTY	TOTAL SHEETS	SHEET NO.
*	(99-1HB-1) R-1	WILL	1508	542
CONTRACT NO. 60X10				
* FAI 55, FAP 856 [ILLINOIS] FED. AID PROJECT				

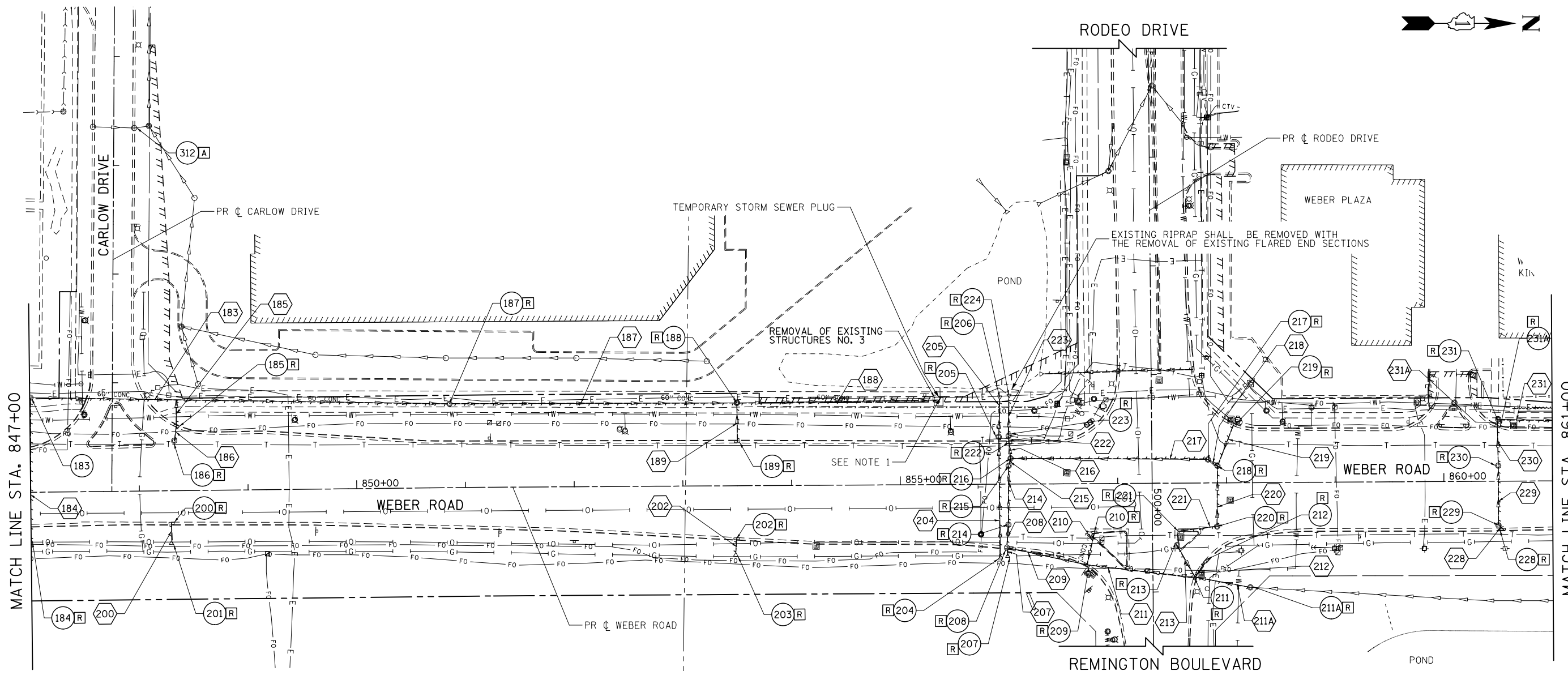

NOTES

1. THE EXISTING OUTLET INTO THE POND, REMOVAL OF EXISTING STRUCTURES NO. 3, AND UPSTREAM PIPES ARE SUBMERGED. THE LOCATIONS AND THE SIZES OF THE DRAINAGE STRUCTURES AND PIPES SHALL BE VERIFIED BY THE CONTRACTOR.

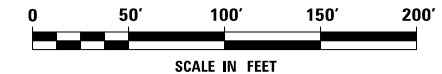
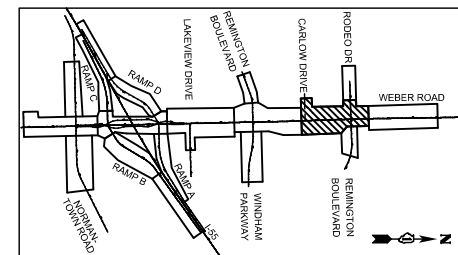

FILE NAME : D:\60X10-shr-drain\05-exdr-am-weber.dgn



USER NAME = mmaestra	DESIGNED REM	REVISED -
DRAWN SAN	CHECKED PJO	REVISED -
PLOT SCALE = 1:100	DATE 05/12/17	REVISED -
PLOT DATE = 5/15/2017		

**STATE OF ILLINOIS
DEPARTMENT OF TRANSPORTATION**

EXISTING DRAINAGE PLAN - WEBER ROAD

SCALE: AS SHOWN SHEET NO. 5 OF 17 SHEETS STA. TO STA.

F.A.I./P RTE.	SECTION	COUNTY	TOTAL SHEETS	SHEET NO.
*	(99-1HB-1) R-1	WILL	1508	543
CONTRACT NO. 60X10				
* FAI 55, FAP 856 ILLINOIS FED. AID PROJECT				

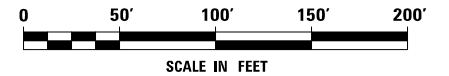
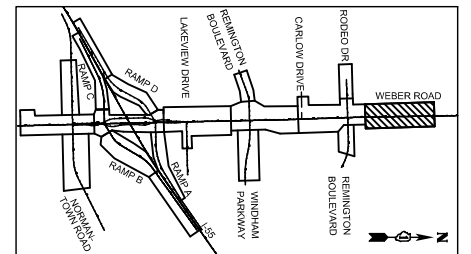
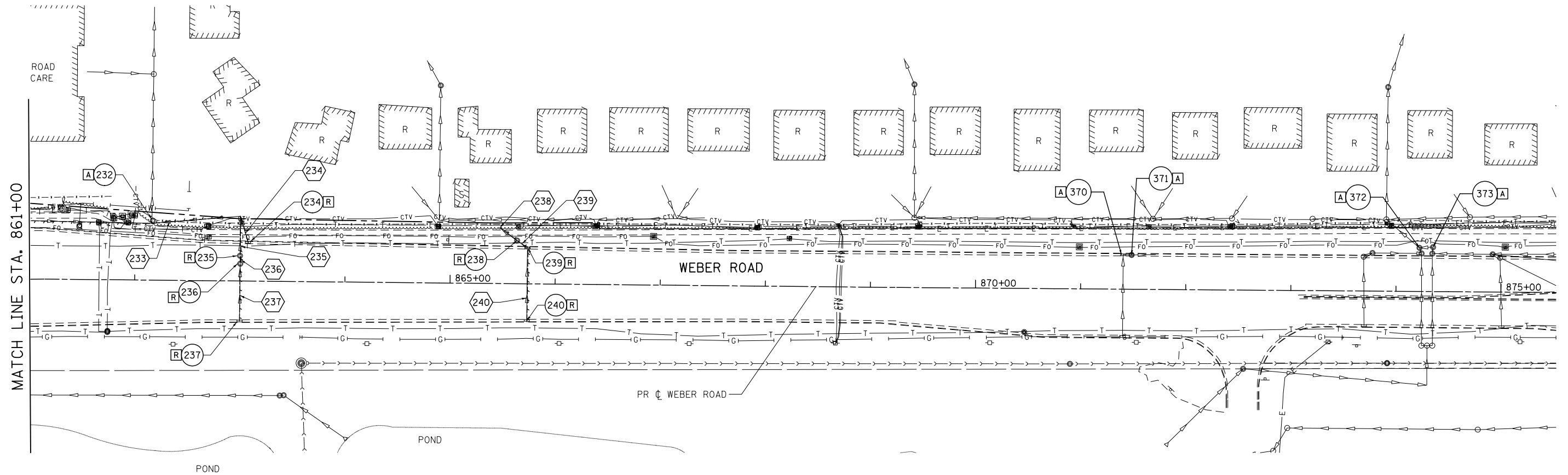
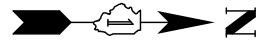

FILE NAME : D:\60X10-shr-drain06-exdr-01-Weber.dgn

KNIGHT
Engineers & Architects

USER NAME = mmaestra	DESIGNED REM	REVISED
PLOT SCALE = 1:100	DRAWN SAN	REVISED -
PLOT DATE = 8/24/2017	CHECKED PJO	REVISED -
	DATE 08/25/17	REVISED -

STATE OF ILLINOIS
DEPARTMENT OF TRANSPORTATION

EXISTING DRAINAGE PLAN - WEBER ROAD
SCALE: AS SHOWN SHEET NO. 6 OF 17 SHEETS STA. TO STA.

F.A.I./P RTE.	SECTION	COUNTY	TOTAL SHEETS	SHEET NO.
*	(99-1HB-1) R-1	WILL	1508	544
CONTRACT NO. 60X10				
* FAI 55, FAP 856 [ILLINOIS] FED. AID PROJECT				

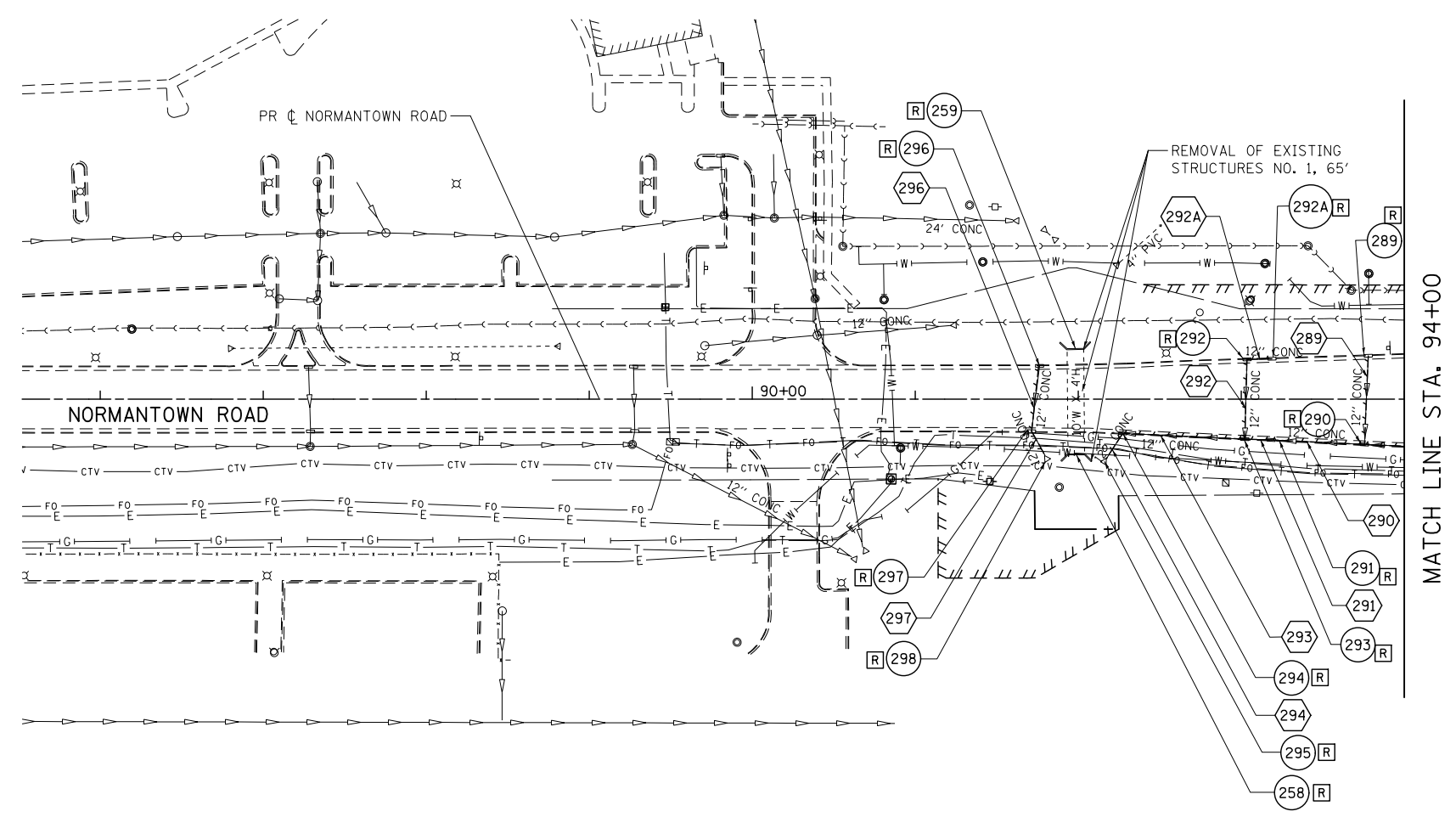

MATCH LINE STA. 94+00

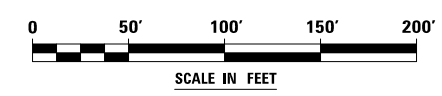
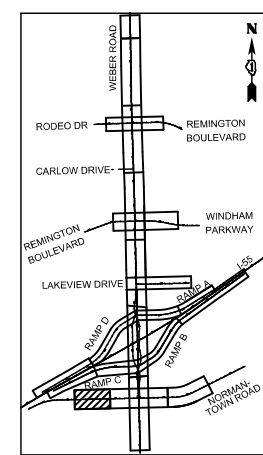

FILE NAME : D:\60X10-shr-drain\07-exdrain-Normantown.dgn



USER NAME = mmaestra	DESIGNED REM	REVISED -
DRAWN SAN	REVISIONS	REVISED -
PLOT SCALE = 1:100	CHECKED PJO	REVISED -
PLOT DATE = 5/13/2017	DATE 05/12/17	REVISED -

**STATE OF ILLINOIS
DEPARTMENT OF TRANSPORTATION**

EXISTING DRAINAGE PLAN - NORMANTOWN ROAD

SCALE: AS SHOWN SHEET NO. 7 OF 17 SHEETS STA. TO STA.

F.A.I./P RTE.	SECTION	COUNTY	TOTAL SHEETS	SHEET NO.
*	(99-1HB-1) R-1	WILL	1508	545
* FAI 55, FAP 856 [ILLINOIS] FED. AID PROJECT			CONTRACT NO. 60X10	

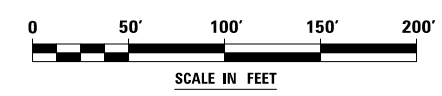
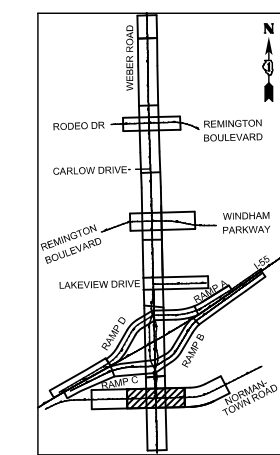
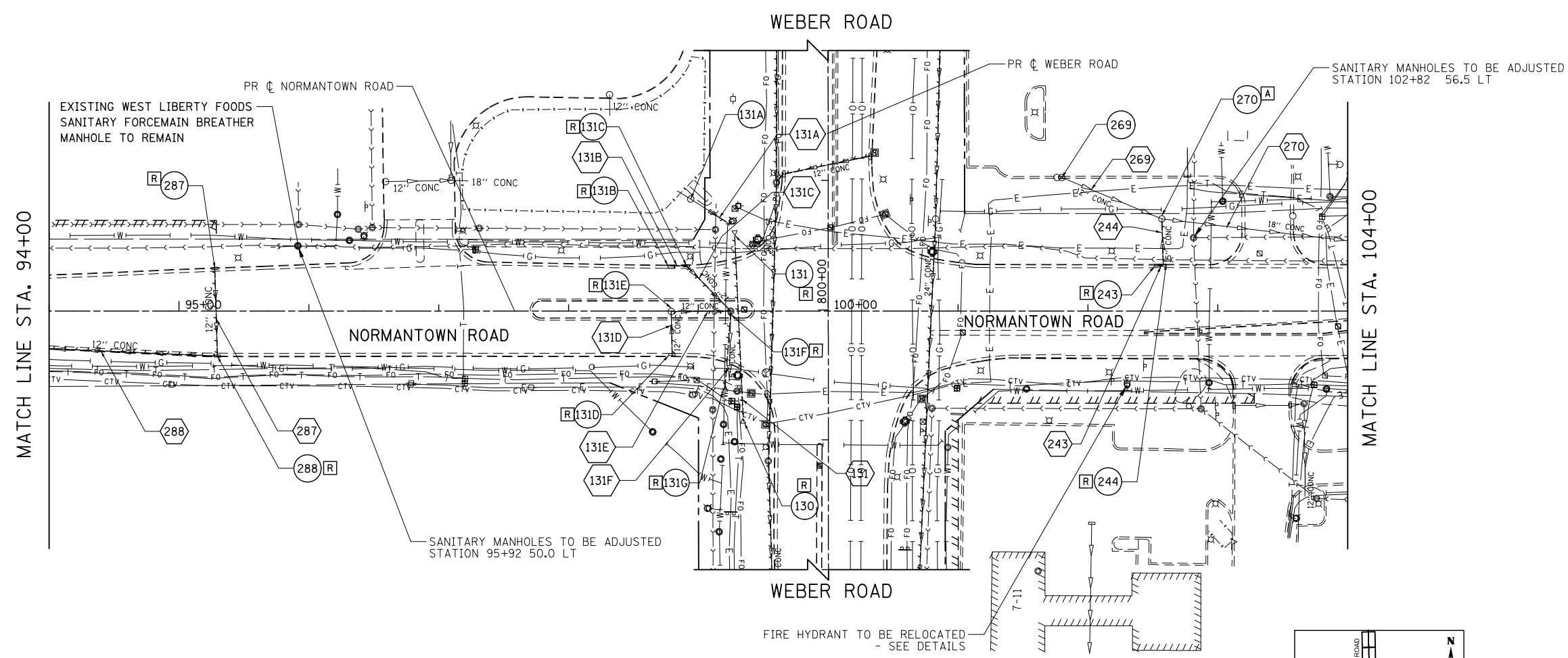

FILE NAME : D:\60X10-shr-drain\08-exdrain-Normantown.dgn



USER NAME = mmaestra	DESIGNED REM	REVISED -
DRAWN SAN	REVISOR SAN	REVISED -
PLOT SCALE = 1:1000	CHECKED PJO	REVISED -
PLOT DATE = 5/13/2017	DATE 05/12/17	REVISED -

**STATE OF ILLINOIS
DEPARTMENT OF TRANSPORTATION**

EXISTING DRAINAGE PLAN - NORMANTOWN ROAD

SCALE: AS SHOWN SHEET NO. 8 OF 17 SHEETS STA. TO STA.

F.A.I./P RTE.	SECTION	COUNTY	TOTAL SHEETS	SHEET NO.
*	(99-1HB-1) R-1	WILL	1508	546
CONTRACT NO. 60X10				
* FAI 55, FAP 856 ILLINOIS FED. AID PROJECT				

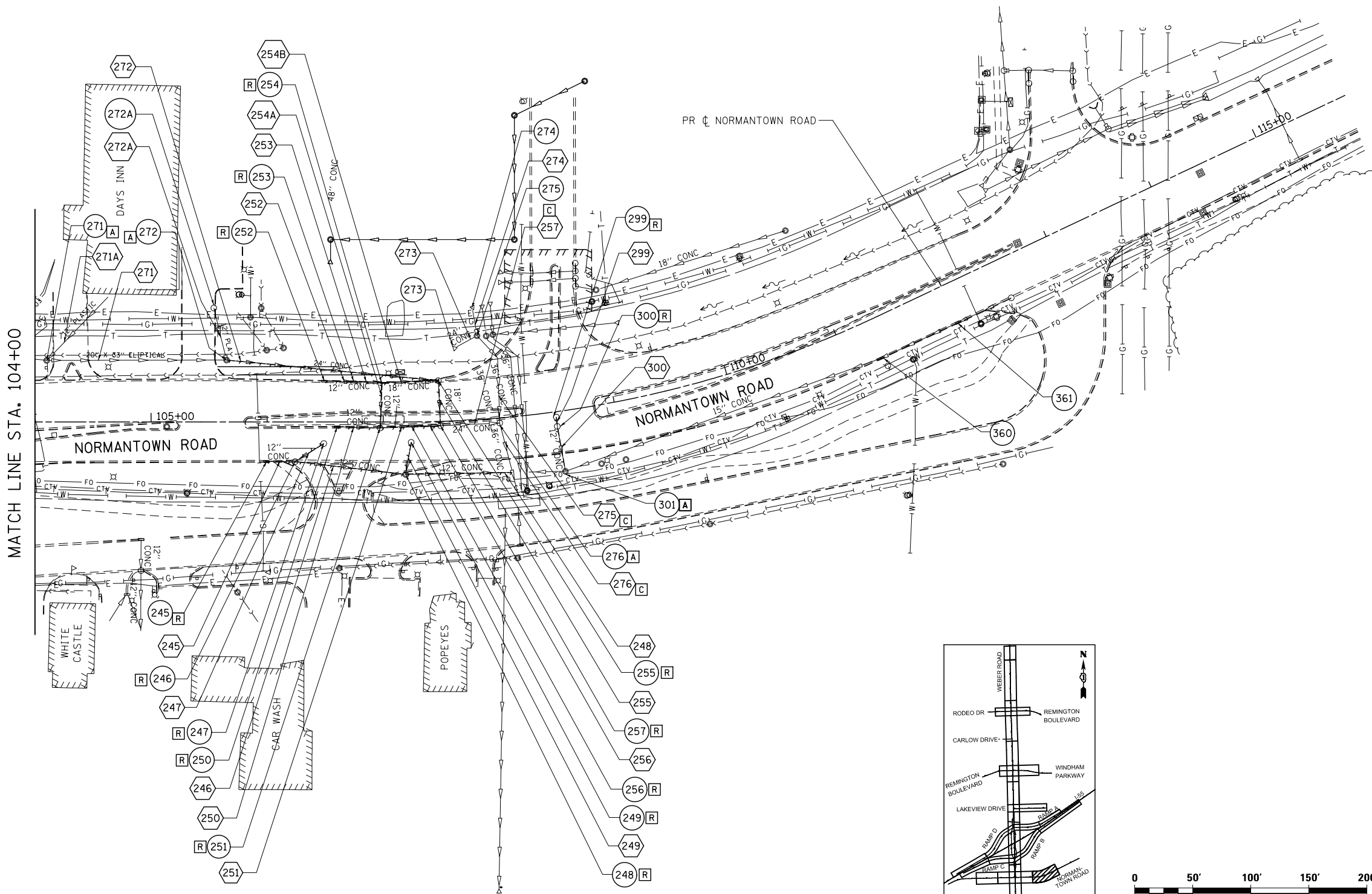
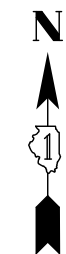

MATCH LINE STA. 104+00

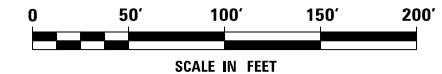
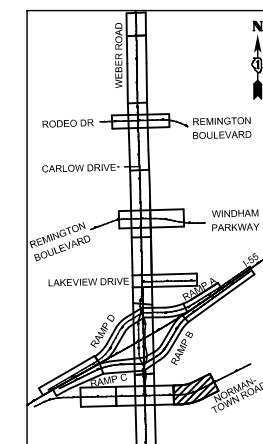

FILE NAME : D:\60X10-shr-draw\09-exdr-ain-Normantown.dgn

KNIGHT
Engineers & Architects

USER NAME = mmaestra	DESIGNED REM	REVISED -
DRAWN SAN	REVISOR SAN	REVISED -
PLOT SCALE = 1:100	CHECKED PJO	REVISED -
PLOT DATE = 5/13/2017	DATE 05/12/17	REVISED -

**STATE OF ILLINOIS
DEPARTMENT OF TRANSPORTATION**

EXISTING DRAINAGE PLAN - NORMANTOWN ROAD

SCALE: AS SHOWN SHEET NO. 9 OF 17 SHEETS STA. TO STA.

F.A.I./P RTE.	SECTION	COUNTY	TOTAL SHEETS	SHEET NO.
*	(99-1HB-1) R-1	WILL	1508	547
CONTRACT NO. 60X10			* FAI 55, FAP 856 ILLINOIS FED. AID PROJECT	

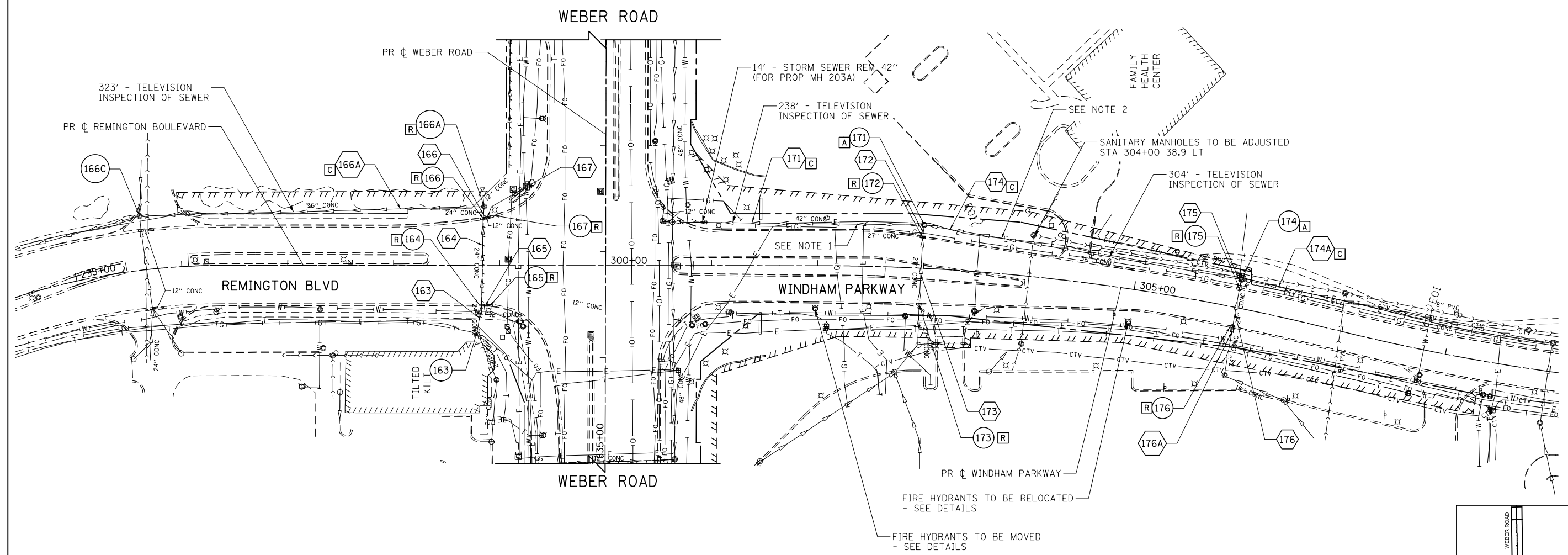

NOTES

- POSSIBLE CONFLICT WITH PROPOSED LIGHTING (SEE LIGHTING PLANS FOR LIGHT POLE LOCATION). A QUANTITY OF 40 FT OF STORM SEWER REMOVAL 42" AND STORM SEWERS, CLASS A, TYPE 1 42" CENTERED ON PROPOSED LIGHT POLE HAS BEEN PROVIDED BETWEEN EXISTING MANHOLES 171 AND 170 FOR THE POSSIBLE CONFLICT. STORM SEWER SHALL ONLY BE REMOVED AND REPLACED IF THE PROPOSED LIGHT POLE IS IN CONFLICT WITH THE EXISTING STORM SEWER.
- POSSIBLE CONFLICT WITH PROPOSED LIGHTING (SEE LIGHTING PLANS FOR LIGHT POLE LOCATION). A QUANTITY OF 40 FT OF STORM SEWER REMOVAL 36" AND STORM SEWERS, CLASS A, TYPE 1 36" CENTERED ON PROPOSED LIGHT POLE HAS BEEN PROVIDED BETWEEN EXISTING MANHOLES 174 AND 171 FOR THE POSSIBLE CONFLICT. STORM SEWER SHALL ONLY BE REMOVED AND REPLACED IF THE PROPOSED LIGHT POLE IS IN CONFLICT WITH THE EXISTING STORM SEWER.

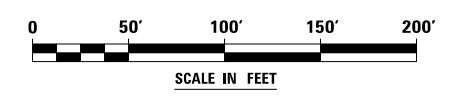
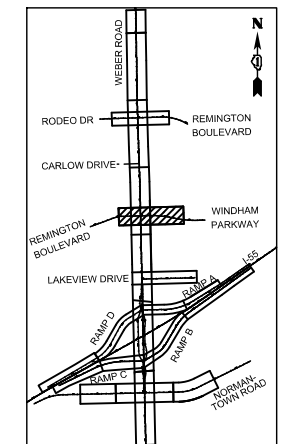

FILE NAME : D:\60X10-shr-draw\10-exdrain-RemingtonWindham.dgn

KNIGHT Engineers & Architects	USER NAME = mmaestra	DESIGNED REM	REVISED -
	PLOT SCALE = 1:100	DRAWN SAN	REVISED -
	PLOT DATE = 5/13/2017	CHECKED PJO	REVISED -
		DATE 05/12/17	REVISED -

**STATE OF ILLINOIS
DEPARTMENT OF TRANSPORTATION**

**EXISTING DRAINAGE PLAN
REMINGTON BLVD / WINDHAM PARKWAY**

SCALE: AS SHOWN | SHEET NO. 10 OF 17 SHEETS | STA. TO STA.

F.A.I./P RTE.	SECTION	COUNTY	TOTAL SHEETS	SHEET NO.
*	(99-1HB-1) R-1	WILL	1508	548
CONTRACT NO. 60X10				
* FAI 55, FAP 856 ILLINOIS FED. AID PROJECT				

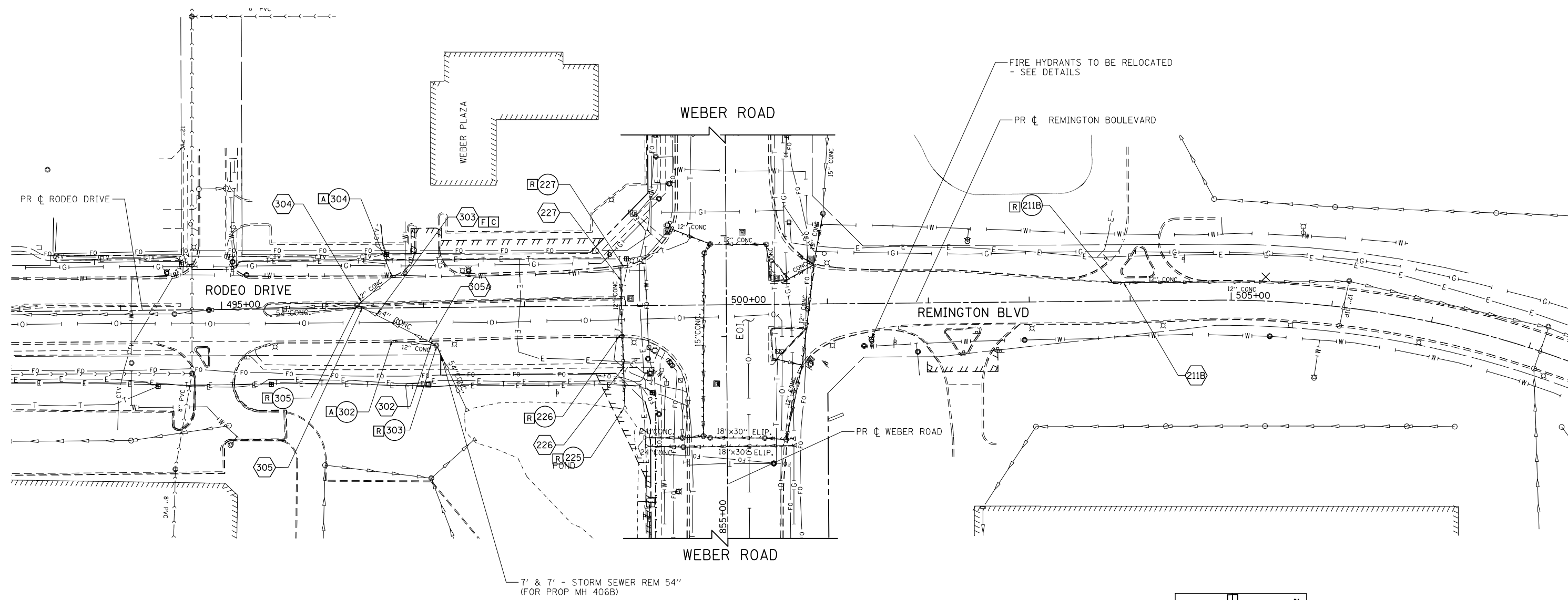

7' & 7' - STORM SEWER REM 54"
(FOR PROP MH 406B)

FIRE HYDRANTS TO BE RELOCATED
- SEE DETAILS

PR REMINGTON BOULEVARD

PR WEBER ROAD

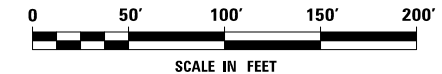
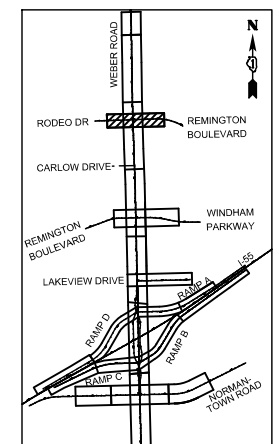

FILE NAME : D:\60X10-shr-drain\ev-drain-RodeoRemington.dgn

KNIGHT
Engineers & Architects

USER NAME = mmaestra	DESIGNED REM	REVISED -
DRAWN SAN	REVISOR SAN	REVISED -
PLOT SCALE = 1:1000	CHECKED PJO	REVISED -
PLOT DATE = 5/15/2017	DATE 05/12/17	REVISED -

**STATE OF ILLINOIS
DEPARTMENT OF TRANSPORTATION**

**EXISTING DRAINAGE PLAN
RODEO DRIVE / REMINGTON BLVD**

SCALE: AS SHOWN SHEET NO. 11 OF 17 SHEETS STA. TO STA.

F.A.I./P RTE.	SECTION	COUNTY	TOTAL SHEETS	SHEET NO.
*	(99-1HB-1) R-1	WILL	1508	549
CONTRACT NO. 60X10				
* FAI 55, FAP 856 ILLINOIS FED. AID PROJECT				

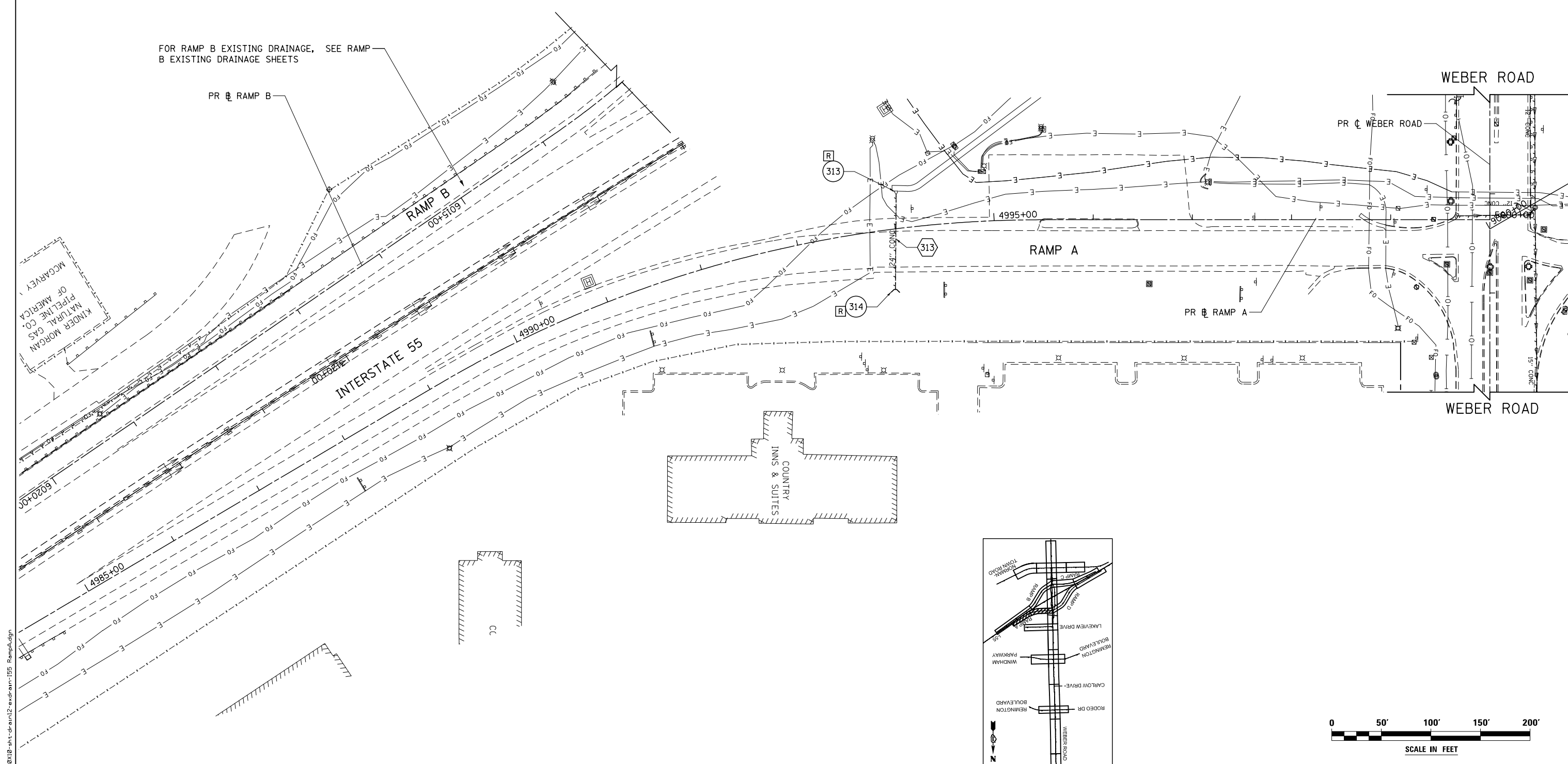

FILE NAME : D:\60X10-shd-drain\2-ex-drain-155 RampA.dgn

KNIGHT
Engineers & Architects

USER NAME = mmaestra	DESIGNED REM	REVISED -
DRAWN SAN		REVISED -
CHECKED PJO		REVISED -
DATE 05/12/17		REVISED -

**STATE OF ILLINOIS
DEPARTMENT OF TRANSPORTATION**

EXISTING DRAINAGE PLAN - RAMP A
SCALE: AS SHOWN SHEET NO. 12 OF 17 SHEETS STA. TO STA.

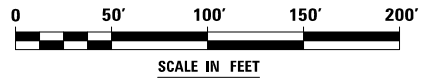
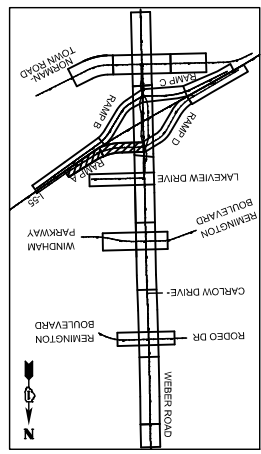

F.A.I./P RTE.	SECTION	COUNTY	TOTAL SHEETS	SHEET NO.
*	(99-1HB-1) R-1	WILL	1508	550
CONTRACT NO. 60X10			* FAI 55, FAP 856 [ILLINOIS] FED. AID PROJECT	

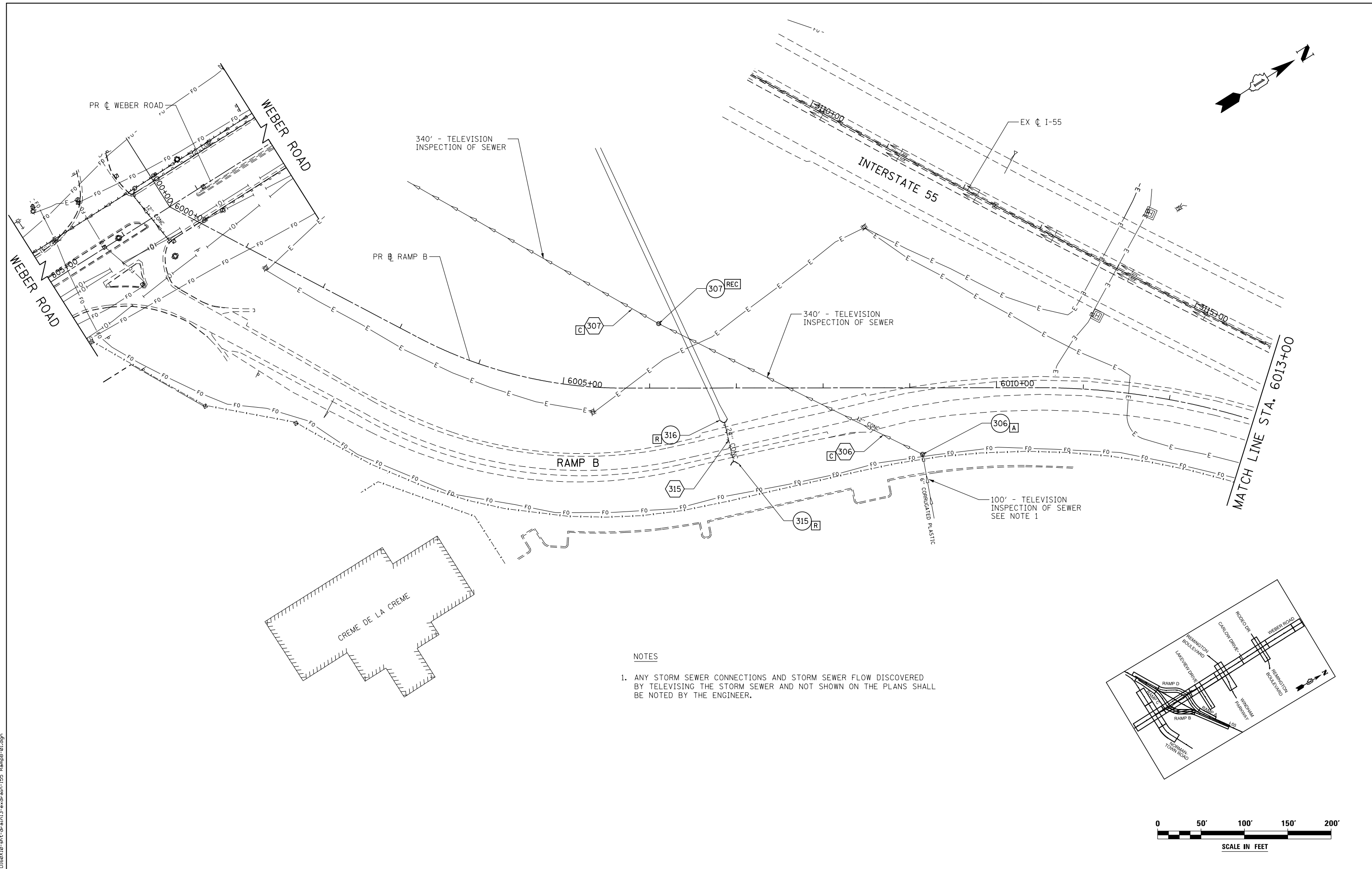

NOTES

1. ANY STORM SEWER CONNECTIONS AND STORM SEWER FLOW DISCOVERED BY TELEVISIONING THE STORM SEWER AND NOT SHOWN ON THE PLANS SHALL BE NOTED BY THE ENGINEER.

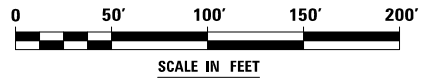
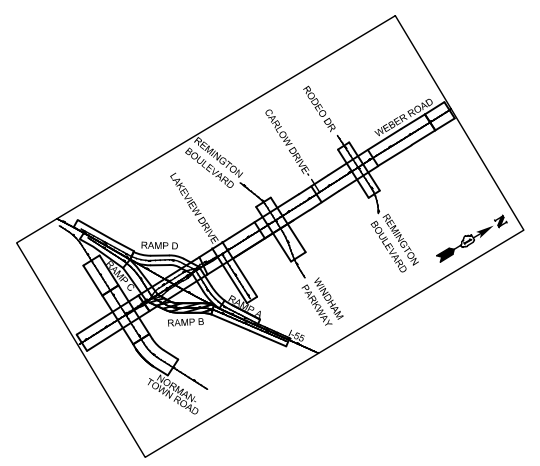

FILE NAME : D:\60X10-shr-drain\3-ex-drain-155 RampB-01.dgn

KNIGHT Engineers & Architects	USER NAME = mmaestra	DESIGNED REM	REVISED -
	PLOT SCALE = 1:1000	DRAWN SAN	REVISED -
	PLOT DATE = 5/13/2017	CHECKED PJO	REVISED -
		DATE 05/12/17	REVISED -

**STATE OF ILLINOIS
DEPARTMENT OF TRANSPORTATION**

EXISTING DRAINAGE PLAN - RAMP B	
SCALE: AS SHOWN	SHEET NO. 13 OF 17 SHEETS
STA.	TO STA.

F.A.I./P RTE.	SECTION	COUNTY	TOTAL SHEETS	SHEET NO.
*	(99-1HB-1) R-1	WILL	1508	551
CONTRACT NO. 60X10				
<small>* FAI 55, FAP 856 ILLINOIS FED. AID PROJECT</small>				

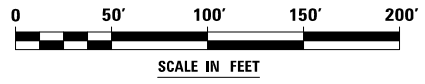
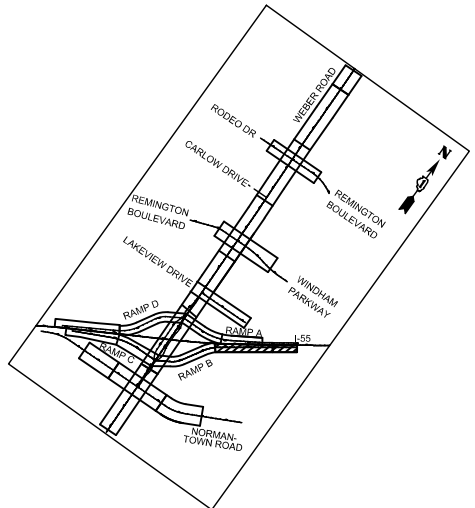
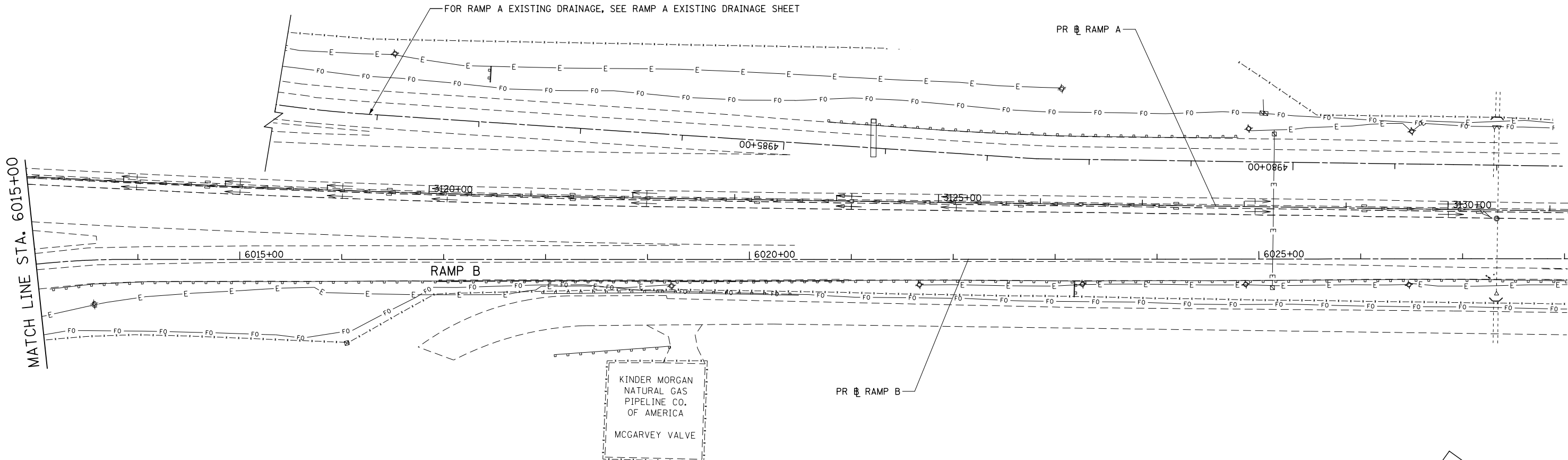
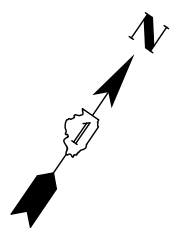

FILE NAME : D:\60X10-shd-drain\4-exdrain-155 RampB-02.dgn

KNIGHT
Engineers & Architects

USER NAME = mmaestra	DESIGNED REM	REVISED -
DRAWN SAN	DRAWN SAN	REVISED -
PLOT SCALE = 1:100	CHECKED PJO	REVISED -
PLOT DATE = 5/13/2017	DATE 05/12/17	REVISED -

**STATE OF ILLINOIS
DEPARTMENT OF TRANSPORTATION**

EXISTING DRAINAGE PLAN - RAMP B	
SCALE: AS SHOWN	SHEET NO. 14 OF 17 SHEETS
STA.	TO STA.

F.A.I./P RTE.	SECTION	COUNTY	TOTAL SHEETS	SHEET NO.
*	(99-1HB-1) R-1	WILL	1508	552
CONTRACT NO. 60X10				
* FAI 55, FAP 856 [ILLINOIS] FED. AID PROJECT				

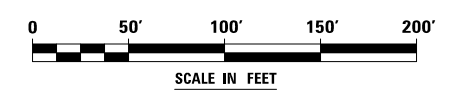
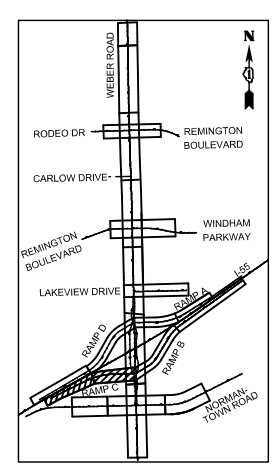
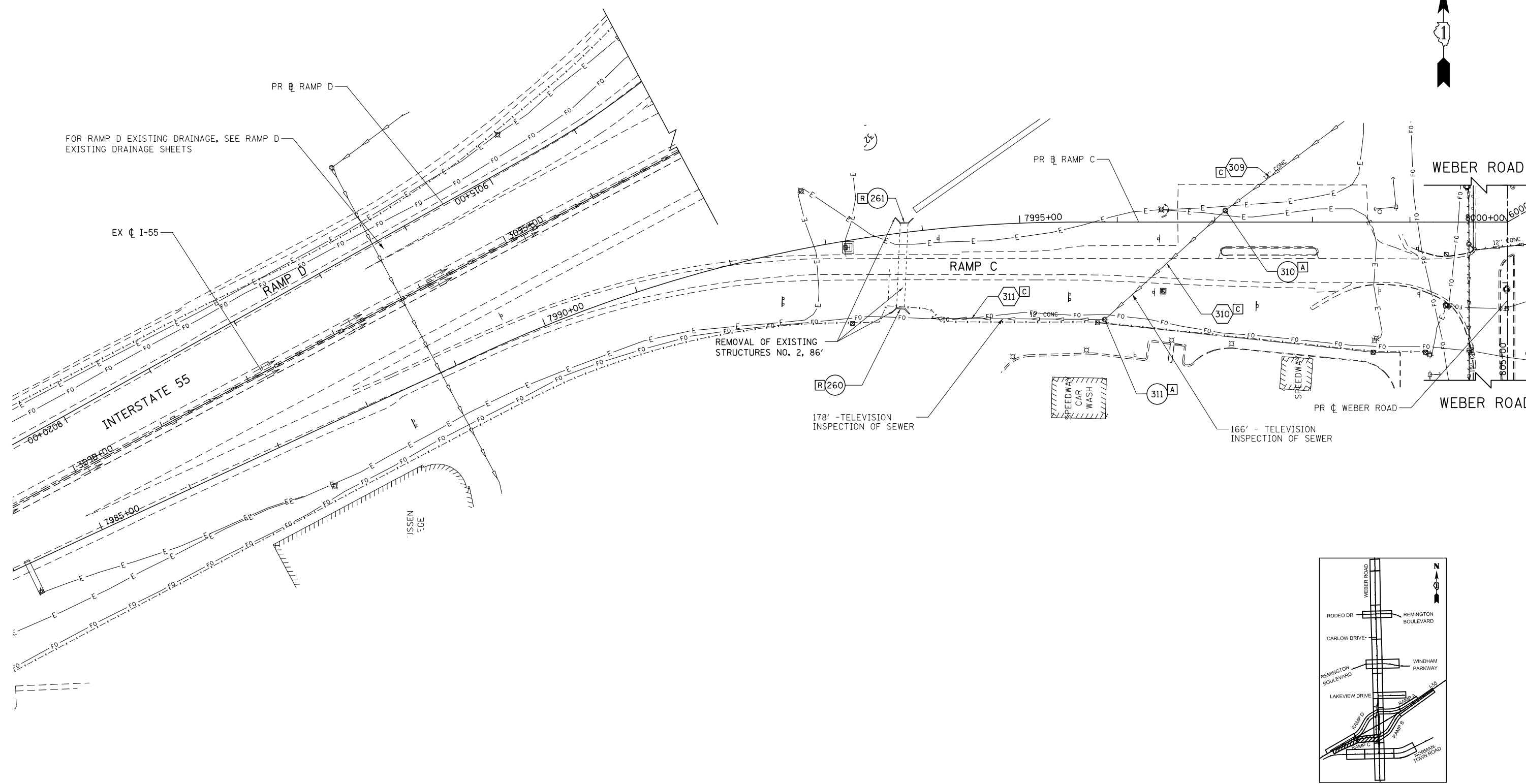
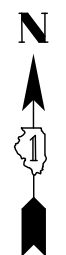

FILE NAME : D:\60X10-shd-drain\5-ex-drain-155 RampC.dgn

KNIGHT
Engineers & Architects

USER NAME = mmaestra	DESIGNED REM	REVISED -
DRAWN SAN	CHECKED PJO	REVISED -
PLOT SCALE = 1:100	DATE 05/12/17	REVISED -
PLOT DATE = 5/13/2017		

**STATE OF ILLINOIS
DEPARTMENT OF TRANSPORTATION**

EXISTING DRAINAGE PLAN - RAMP C

SCALE: AS SHOWN SHEET NO. 15 OF 17 SHEETS STA. TO STA.

F.A.I./P RTE.	SECTION	COUNTY	TOTAL SHEETS	SHEET NO.
*	(99-1HB-1) R-1	WILL	1508	553
CONTRACT NO. 60X10				
* FAI 55, FAP 856 [ILLINOIS] FED. AID PROJECT				

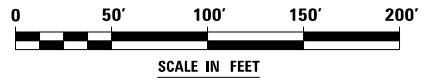
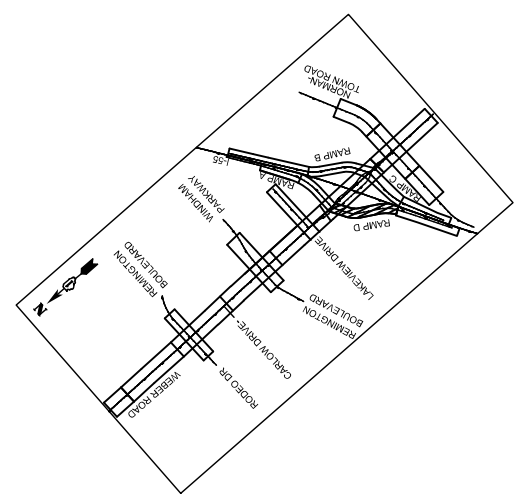
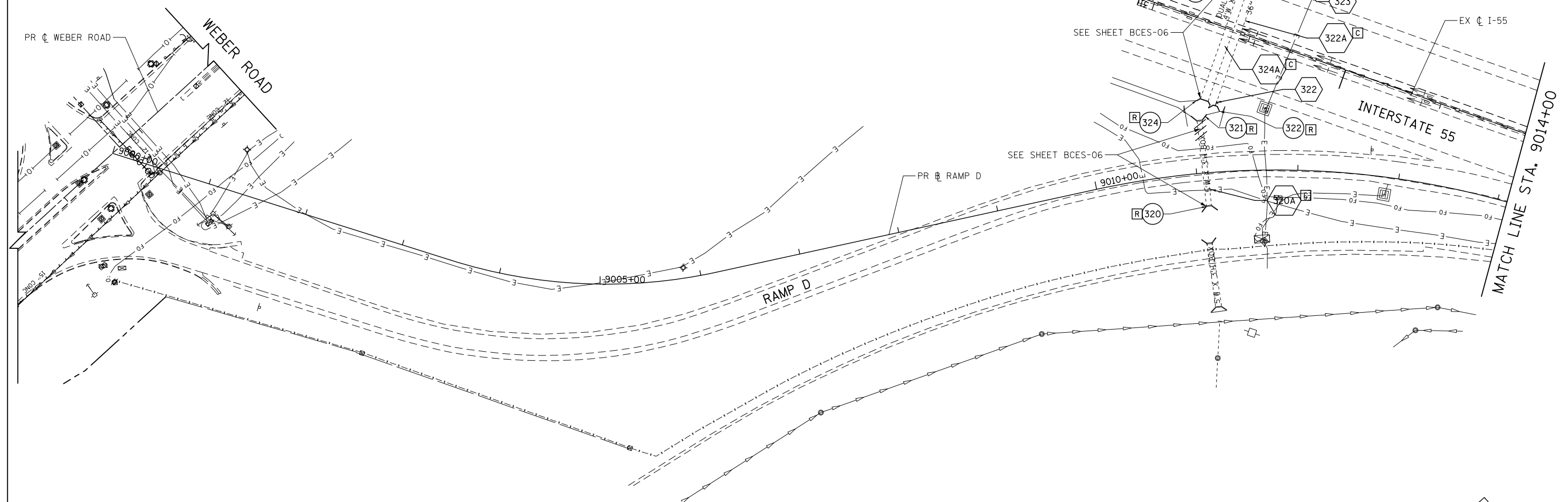
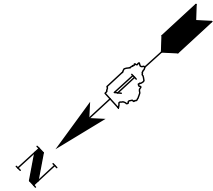

FILE NAME : D:\60X10-shd-drain\6-ex-drain-155 RampD-01.dgn

KNIGHT Engineers & Architects	USER NAME = mmaestra	DESIGNED REM	REVISED -
	PLOT SCALE = 1:100	DRAWN SAN	REVISED -
	PLOT DATE = 5/13/2017	CHECKED PJO	REVISED -
		DATE 05/12/17	REVISED -

**STATE OF ILLINOIS
DEPARTMENT OF TRANSPORTATION**

EXISTING DRAINAGE PLAN - RAMP D

SCALE: AS SHOWN SHEET NO. 16 OF 17 SHEETS STA. TO STA.

F.A.I./P RTE.	SECTION	COUNTY	TOTAL SHEETS	SHEET NO.
*	(99-1HB-1) R-1	WILL	1508	554
				CONTRACT NO. 60X10
* FAI 55, FAP 856 ILLINOIS FED. AID PROJECT				

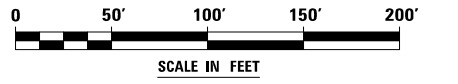
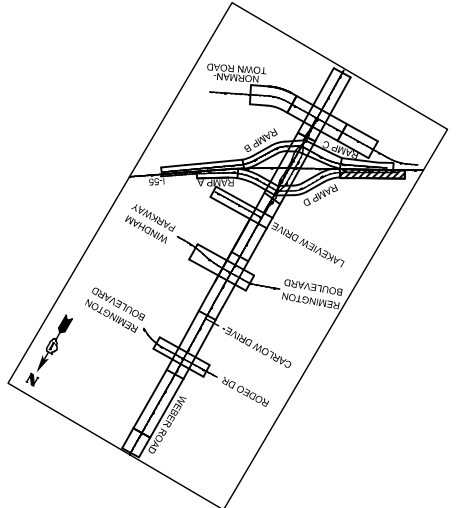
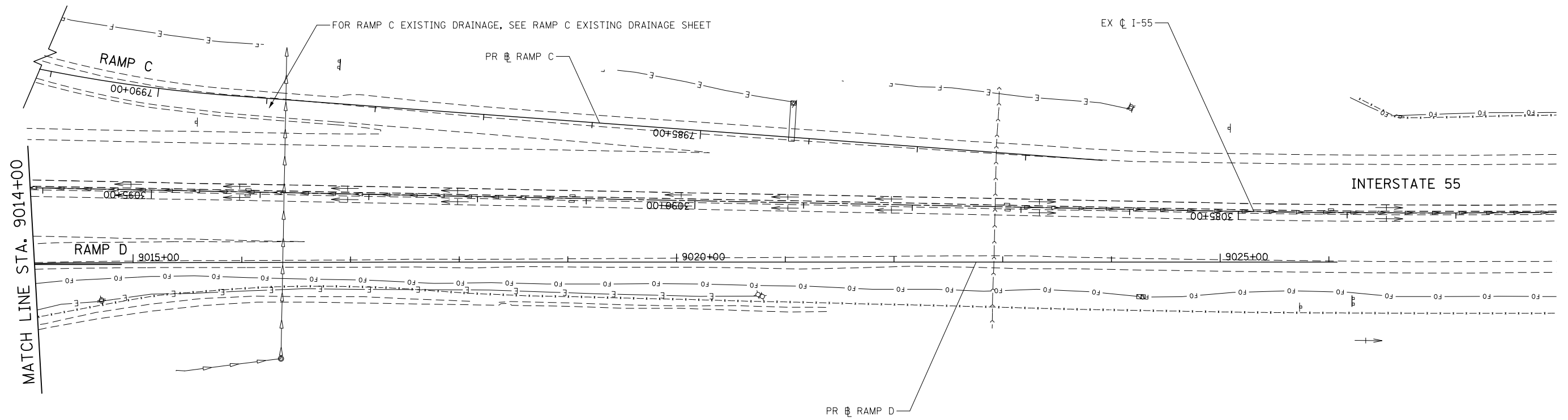
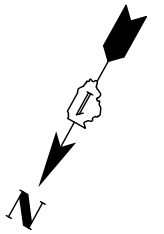

FILE NAME : D:\60X10-shd-drain\7-ex-drain-155 RampD-02.dgn

KNIGHT Engineers & Architects	USER NAME = mmaestra	DESIGNED REM	REVISED -
	PLOT SCALE = 1:100	DRAWN SAN	REVISED -
	PLOT DATE = 5/13/2017	CHECKED PJO	REVISED -
		DATE 05/12/17	REVISED -

**STATE OF ILLINOIS
DEPARTMENT OF TRANSPORTATION**

EXISTING DRAINAGE PLAN - RAMP D

SCALE: AS SHOWN SHEET NO. 17 OF 17 SHEETS STA. TO STA.

F.A.I./P RTE.	SECTION	COUNTY	TOTAL SHEETS	SHEET NO.
*	(99-1HB-1) R-1	WILL	1508	555
CONTRACT NO. 60X10				
* FAI 55, FAP 856 [ILLINOIS] FED. AID PROJECT				

STRUCTURE NUMBER	LOCATION			RIM ELEVATION	INVERT								STRUCTURE TYPE	COMMENTS
	ALIGNMENT	STATION	OFFSET		N	NE	E	SE	S	SW	W	NW		
1 *	SB WEBER RD	1810+68.0	1.2 RT	671.52					666.94				INLETS TA T24F&G	
1A *	SB WEBER RD	1809+69.0	10.8 RT	669.54	664.12				664.02				CB TA 4 DIA T24F&G	
1B *	SB WEBER RD	1810+42.4	56.0 LT	671.21					666.78				INLETS TA T24F&G	
1C *	SB WEBER RD	1809+67.6	56.0 LT	669.77	665.12				662.62				CB TA 4 DIA T24F&G	
2 *	SB WEBER RD	1808+68.1	34.8 RT	665.46	660.87			659.87					CB TA 4 DIA T24F&G	
3 *	RAMP B	6001+86.6	33.2 LT	661.83			655.67		655.42		656.67		CB TA 4 DIA T24F&G	
3A *	RAMP B	6002+78.9	12.4 LT	659.64						656.07			INLETS TA T24F&G	
4 *	NB WEBER RD	2810+01.1	0.0 LT	670.98					666.33				INLETS TA T24F&G	
5 *	SB WEBER RD	1808+77.7	56.0 LT	667.63	660.79				658.95		658.79		CB TA 4 DIA T24F&G	
6 *	NB WEBER RD	2808+86.9	0.0 LT	668.16	663.00		658.45		658.20				CB TA 4 DIA T24F&G	
7 *	SB WEBER RD	1807+45.5	56.0 LT	664.15		660.08							INLETS TA T24F&G	
8 *	SB WEBER RD	1807+67.9	56.0 LT	664.80	659.85				659.99				CB TA 4 DIA T24F&G	
10 *	NB WEBER RD	2808+04.7	24.7 LT	664.97	655.68						655.58		CB TA 4 DIA T24F&G	
11 *	NB WEBER RD	2808+07.1	34.3 LT	664.63			655.40		655.20	655.70			MAN TA 6 DIA T1F CL	
12 *	SB WEBER RD	1806+51.3	57.2 LT	661.33						657.22			INLETS TA T24F&G	
13 *	SB WEBER RD	1805+70.2	56.0 LT	658.37							654.40		INLETS TA T24F&G	
14	SB WEBER RD	1805+98.3	89.0 LT	658.65		655.22		654.22			653.47		CB TA 4 DIA T8G	6 IN ADJUSTING RINGS TO BE USED
15 *	RAMP C	7998+21.1	34.4 LT	660.03		656.11							INLETS TA T24F&G	
16	NB WEBER RD	2806+79.4	65.9 LT	659.50	651.18			653.08	651.08				MAN TA 6 DIA T1F CL	
17 *	SB WEBER RD	1805+21.3	59.6 LT	656.54						651.84			CB TA 4 DIA T24F&G	
18 *	NB WEBER RD	2805+78.2	107.2 LT	656.82	647.93		651.80		647.80				MAN TA 4 DIA T1F CL	ROTATE TOP - SET LID OUTSIDE PATH
19 *	RAMP B	6001+21.5	11.2 LT	660.40		654.12		653.92		654.17			CB TA 4 DIA T8G	6 IN ADJUSTING RINGS TO BE USED
20 *	RAMP B	6001+40.7	34.6 RT	660.64						653.48	653.77		MAN TA 4 DIA T1F CL	
21 *	SB WEBER RD	1807+18.7	0.0 LT	663.35						659.34			INLETS TA T24F&G	
22 *	SB WEBER RD	1806+63.5	0.0 LT	661.72		657.72		656.22					CB TA 4 DIA T24F&G	
23 *	NB WEBER RD	2805+28.0	42.0 RT	656.67			652.06				652.56		CB TA 4 DIA T24F&G	
23A	NB WEBER RD	2805+88.8	71.1 RT	658.20		654.71							CB TA 4 DIA T8G	6 IN ADJUSTING RINGS TO BE USED
24 *	NB WEBER RD	2805+20.6	72.5 RT	656.19			650.72				651.22		CB TA 4 DIA T24F&G	
25 *	NB WEBER RD	2805+16.9	89.5 RT	655.88		650.20			650.00	650.30			MAN TA 4 DIA T1F CL	ROTATE TOP - SET LID OUTSIDE PATH
26	NB WEBER RD	2804+05.9	73.6 RT	652.99	647.32				645.82	646.49			MAN TA 4 DIA T1F CL	ROTATE TOP - SET LID OUTSIDE PATH
26A	NB WEBER RD	2804+06.1	56.0 RT	652.73			646.56						CB TA 4 DIA T24F&G	
28 *	SB WEBER RD	1804+09.5	56.1 LT	652.89							647.63		CB TA 4 DIA T24F&G	
29 *	NB WEBER RD	2803+83.6	121.5 LT	653.11	644.14		647.61		643.61				MAN TA 5 DIA T1F CL	ROTATE TOP - SET LID OUTSIDE PATH
30	SB WEBER RD	1803+29.1	82.7 LT	647.36			643.33						CB TA 4 DIA T8G	6 IN ADJUSTING RINGS TO BE USED
30A *	NB WEBER RD	2803+11.6	104.3 LT	651.21	642.28				640.24	643.24			MAN TA 5 DIA T1F CL	ROTATE TOP - SET LID OUTSIDE PATH
31 *	SB WEBER RD	1802+50.0	48.0 LT	648.34							642.41		CB TA 4 DIA T24F&G	
31A *	NB WEBER RD	2802+49.9	99.0 LT	648.94	638.91		642.23		636.89				MAN TA 5 DIA T1F CL	ROTATE TOP - SET LID OUTSIDE PATH
32 *	NB WEBER RD	2801+24.0	99.0 LT	645.35	634.59		635.51	633.59					MAN TA 6 DIA T1F CL	ROTATE TOP - SET LID OUTSIDE PATH
33	NB WEBER RD	2802+44.2	65.9 RT	648.20	642.76				640.76	641.88			MAN TA 4 DIA T1F CL	ROTATE TOP - SET LID OUTSIDE PATH
33A *	NB WEBER RD	2802+45.0	48.3 RT	648.15			642.02						CB TA 4 DIA T24F&G	
34	NB WEBER RD	2801+00.0	87.3 RT	641.50							637.54		CB TA 4 DIA T8G	6 IN ADJUSTING RINGS TO BE USED
35 *	NB WEBER RD	2801+23.7	71.2 RT	644.68	638.44			637.42		638.42	636.42		MAN TA 5 DIA T1F CL	ROTATE TOP - SET LID OUTSIDE PATH
35A *	NB WEBER RD	2801+00.1	58.2 RT	643.60		638.53							CB TA 4 DIA T24F&G	
36 *	SB WEBER RD	1801+23.7	24.0 RT	645.68	639.95		636.05		639.95		635.95		MAN TA 5 DIA T1F CL	
36A *	SB WEBER RD	1801+37.7	24.0 RT	646.10					640.05				CB TA 4 DIA T11V F&G	
37 *	SB WEBER RD	1801+00.0	24.0 RT	644.97	640.15								CB TA 4 DIA T11V F&G	
38 *	SB WEBER RD	1801+06.0	48.0 LT	644.07						638.08			CB TA 4 DIA T24F&G	
39 *	NB WEBER RD	2801+00.0	83.5 LT	644.32		638.04		633.04	635.00		633.18		MAN TA 7 DIA T1F CL	
39A	NB WEBER RD	2800+64.0	108.9 LT	640.80		635.27				635.47			CB TA 4 DIA T8G	6 IN ADJUSTING RINGS TO BE USED

PIPE NUMBER	PIPE LENGTH (FOOT)	PIPE TYPE AND SIZE	PIPE SLOPE	TRENCH BACKFILL	CONTR LOWSTR MATL SPL	COMMENTS
				(CU YD)	(CU YD)	
1	94	STORM SEW CL A 2 12	3.00%		24	
1A	105	STORM SEW CL A 2 12	3.00%		28	
1B	83	STORM SEW CL A 2 12	2.00%		17	
1C	73	STORM SEW CL A 2 12	2.50%		54	
2	80	STORM SEW CL A 2 12	4.00%		24	
3	65	STORM SEW CL A 2 15	2.00%		27	
3A	91	STORM SEW CL A 2 12	0.44%		22	
4	111	STORM SEW CL A 2 12	3.00%		27	
5	103	STORM SEW CL A 2 15	0.33%	120	-	
6	84	STORM SEW CL A 2 18	3.00%	-	-	
7	17	STORM SEW CL A 2 12	0.50%		4	
8	90	STORM SEW CL A 2 12	1.00%		42	
10	6	STORM SEW CL A 2 18	3.00%		8	
11	134	STORM SEW CL A 2 18	3.00%		151	
12	57	STORM SEW CL A 1 12	3.50%	8	-	
13	40	STORM SEW CL A 2 12	0.44%	8	-	
14	13	STORM SEW CL A 2 12	3.00%	-	-	
15	92	STORM SEW CL A 2 12	0.44%		39	
16	105	STORM SEW CL A 2 18	3.00%		115	
17	7	STORM SEW CL A 2 12	0.50%	2	-	
18	122	STORM SEW CL A 2 18	3.00%	163	-	
19	46	STORM SEW CL A 2 15	0.33%		22	
20	164	STORM SEW CL A 2 15	2.00%	151	-	
21	54	STORM SEW CL A 1 12	3.00%		9	
22	122	STORM SEW CL A 2 12	3.00%	-	-	
23	28	STORM SEW CL A 2 12	3.00%		7	
23A	122	STORM SEW CL A 2 12	0.44%	-	-	
24	14	STORM SEW CL A 2 12	3.00%		5	
25	134	STORM SEW CL A 2 15	2.00%		49	
26	153	STORM SEW CL A 2 15	2.00%		66	
26A	14	STORM SEW CL A 2 12	0.50%		6	
28	3	STORM SEW CL A 2 12	0.50%	1	-	
29	70	STORM SEW CL A 2 24	1.90%	103	-	
30	9	STORM SEW CL A 2 12	1.00%	-	-	
30A	70	STORM SEW CL A 2 24	1.90%	121	-	
31	18	STORM SEW CL A 2 12	1.00%	8	-	
31A	121	STORM SEW CL A 2 24	1.90%	231	-	
32	22	STORM SEW CL A 2 24	1.90%	43	-	
33	116	STORM SEW CL A 2 15	2.00%		57	
33A	14	STORM SEW CL A 2 12	1.00%		6	
34	24	STORM SEW CL A 2 12	0.50%	9	-	
35	73	STORM SEW CL A 2 18	0.50%		84	
35A	23	STORM SEW CL A 2 12	0.50%		8	
36	88	STORM SEW CL A 2 18	0.50%		114	
36A	10	STORM SEW CL A 2 12	1.00%		4	
37	20	STORM SEW CL A 2 12	1.00%		6	
38	4	STORM SEW CL A 2 12	1.00%		2	
39	247	STORM SEW WM REQ 24	1.90%		346	
39A	9	SS RG CL A 2 12	0.44%	-	-	

- * INDICATES PROPOSED STRUCTURE SHALL BE BACKFILLED WITH CLSM, SPECIAL.
- * EXISTING PIPE TO BE CONNECTED TO PROPOSED DRAINAGE STRUCTURE. THE CONTRACTOR SHALL VERIFY EXISTING INVERT PRIOR TO STRUCTURE FABRICATION.
- ** SEE IDOT STANDARD DETAIL 542311 TRAVERSABLE PIPE GRATE OR DRAINAGE DETAILS FOR SCHEDULE AND DETAILS OF CONCRETE END SECTIONS OR HEADWALLS THAT REQUIRE TRAVERSABLE PIPE GRATES.

FILE NAME : D:\60X10-shr-drain\DrainageSchedule01.dgn

	USER NAME : dbarnes	DESIGNED REM	REVISED -	STATE OF ILLINOIS DEPARTMENT OF TRANSPORTATION	PROPOSED DRAINAGE SCHEDULES			F.A.I./P RTE.	SECTION	COUNTY	TOTAL SHEETS	SHEET NO.
	PLOT SCALE = 1:100	DRAWN DGB	REVISED -					*	(99-1HB-1) R-1	WILL	1508	556
	PLOT DATE = 6/14/2017	CHECKED PJO	REVISED -					CONTRACT NO. 60X10				
		DATE 06/16/17	REVISED -					* FAI 55, FAP 856 [ILLINOIS] FED. AID PROJECT				
				SCALE: AS SHOWN			SHEET NO. 1 OF 9 SHEETS		STA.		TO STA.	

STRUCTURE NUMBER	LOCATION			RIM ELEVATION	INVERT								STRUCTURE TYPE	COMMENTS
	ALIGNMENT	STATION	OFFSET		N	NE	E	SE	S	SW	W	NW		
39B	NB WEBER RD	2800+75.0	104.6 LT	640.80		635.13				635.23		637.70*	CB TA 4 DIA T8G	6 IN ADJUSTING RINGS TO BE USED
40 *	NB WEBER RD	2800+39.0	141.2 LT	640.45			635.83						INLETS TA T24F&G	
41 *	NB WEBER RD	2800+42.0	125.9 LT	640.41		635.57			635.77		635.77		CB TA 4 DIA T24F&G	
42 *	NB WEBER RD	2800+05.0	126.0 LT	640.98	635.91				636.11				CB TA 4 DIA T11V F&G	
43 *	WEBER RD	799+57.0	111.0 LT	640.46	636.31								INLETS TA T24F&G	
45 *	WEBER RD	798+50.0	75.0 RT	636.18							631.37		INLETS TA T24F&G	
46 *	WEBER RD	798+50.0	51.0 LT	636.78			630.13				629.93		CB TA 4 DIA T24F&G	
47 *	WEBER RD	798+50.0	66.2 LT	636.89	628.34		629.84		626.34				MAN TA 5 DIA T1F CL	ROTATE TOP - SET LID OUTSIDE PATH
49 *	WEBER RD	796+90.0	73.0 RT	631.48					627.29				INLETS TA T24F&G	
50 *	WEBER RD	795+50.0	59.0 RT	627.78	623.59						623.49		CB TA 4 DIA T24F&G	
50A	WEBER RD	795+50.0	0.0 LT	628.81			623.22				623.12		CB TA 4 DIA T8G	6 IN ADJUSTING RINGS TO BE USED
51 *	WEBER RD	796+90.0	51.0 LT	632.03					623.68				INLETS TA T24F&G	
52 *	WEBER RD	795+50.0	49.2 LT	628.03	622.99		622.89				622.79		CB TA 4 DIA T24F&G	
52A *	WEBER RD	795+50.0	71.8 LT	628.88	622.20		622.70		621.70				MAN TA 5 DIA T1F CL	ROTATE TOP - SET LID OUTSIDE PATH
53 *	WEBER RD	794+00.0	46.0 LT	624.94							619.84		CB TA 4 DIA T24F&G	
54 *	WEBER RD	794+00.0	68.4 LT	625.72	619.66		619.66		619.16				MAN TA 5 DIA T1F CL	ROTATE TOP - SET LID OUTSIDE PATH
55 *	WEBER RD	794+00.0	45.9 RT	624.94					620.74				INLETS TA T24F&G	
56 *	WEBER RD	793+00.0	42.0 LT	623.65	618.65				618.55				CB TA 4 DIA T24F&G	
57 *	WEBER RD	791+00.0	40.0 RT	622.50	618.56								INLETS TA T24F&G	
58 *	WEBER RD	792+00.0	41.0 LT	622.98	617.59				617.59		617.34		CB TA 4 DIA T24F&G	
59 *	WEBER RD	793+00.0	0.0 LT	624.67							619.34		INLETS TA T8G	
60 *	WEBER RD	793+00.0	43.6 LT	623.65			618.91		618.81				CB TA 4 DIA T24F&G	
61 *	WEBER RD	791+00.0	40.0 LT	622.50	618.35								INLETS TA T24F&G	
62 *	WEBER RD	792+00.0	41.0 LT	622.98	617.85		616.94		617.39		616.69		CB TA 5 DIA T24F&G	
63 *	WEBER RD	791+99.0	64.0 LT	622.84	617.20		616.65		616.20				MAN TA 5 DIA T1F CL	ROTATE TOP - SET LID OUTSIDE PATH
63A *	WEBER RD	791+60.0	63.1 LT	621.85	616.03						614.03		MAN TA 6 DIA T1F CL	ROTATE TOP - SET LID OUTSIDE PATH
63B	WEBER RD	791+60.0	75.0 LT	N/A			614.00						CONC ES 542001 30 1:3	** TRAVERSABLE PIPE GRATE; 12 FT
64	WEBER RD	791+10.0	92.0 LT	N/A					613.25				PRC FLAR END SEC 18	
65	WEBER RD	790+95.0	92.0 LT	N/A	613.00								PRC FLAR END SEC 18	
66	WEBER RD	791+10.0	88.0 LT	N/A					613.25				PRC FLAR END SEC 18	
67	WEBER RD	790+95.0	88.0 LT	N/A	613.00								PRC FLAR END SEC 18	
101	WEBER RD	822+92.0	63.4 RT	660.54					657.42				INLETS TA T24F&G	
103 *	NB WEBER RD	2820+62.0	42.7 RT	662.41	658.09								INLETS TA T24F&G	
104 *	NB WEBER RD	2821+58.0	47.7 RT	661.68	657.52				657.62				CB TA 4 DIA T24F&G	
105 *	NB WEBER RD	2822+45.0	48.0 RT	661.12	657.04				657.14		657.04		CB TA 4 DIA T24F&G	
106	NB WEBER RD	2822+45.0	15.0 LT	662.00			656.78				656.78		CB TA 4 DIA T8G	6 IN ADJUSTING RINGS TO BE USED
107 *	WEBER RD	822+92.0	51.0 LT	660.85					657.35				INLETS TA T24F&G	
108 *	NB WEBER RD	2822+45.0	66.0 LT	661.15	656.97		656.57				656.47		CB TA 4 DIA T24F&G	
109 *	NB WEBER RD	2822+45.0	80.0 LT	660.88			656.43		656.35				MAN TA 4 DIA T1F CL	
110 *	NB WEBER RD	2820+54.8	82.7 LT	662.57	658.10								INLETS TA T24F&G	
111 *	NB WEBER RD	2821+57.0	66.6 LT	661.96					657.13		656.63		CB TA 4 DIA T24F&G	
112 *	NB WEBER RD	2821+57.0	80.0 LT	661.87	656.11		656.53		656.03				MAN TA 4 DIA T1F CL	
113 *	NB WEBER RD	2819+57.0	98.5 LT	663.11							658.34		CB TA 4 DIA T24F&G	
114 *	NB WEBER RD	2819+55.0	115.0 LT	662.25	655.46		658.21		655.21				MAN TA 4 DIA T1F CL	
115 *	NB WEBER RD	2817+18.0	0.0 LT	665.90							661.30		INLETS TA T24F&G	
116 *	SB WEBER RD	1818+19.4	42.0 LT	663.96				659.46			658.86		CB TA 4 DIA T24F&G	
116A *	SB WEBER RD	1818+39.1	63.0 LT	663.45				658.43			658.33		CB TA 4 DIA T24F&G	

PIPE NUMBER	PIPE LENGTH (FOOT)	PIPE TYPE AND SIZE	PIPE SLOPE	TRENCH BACKFILL	CONTR LOWSTR MATL SPL	COMMENTS
				(CU YD)	(CU YD)	
39B	29	STORM SEW CL A 2 12	0.44%	12	-	
40	13	STORM SEW CL A 2 12	0.44%	3	-	
41	24	SS RG CL A 2 12	0.44%	7	-	
42	32	STORM SEW CL A 2 12	0.44%	9	-	
43	45	STORM SEW CL A 2 12	0.44%	10	-	
45	124	STORM SEW CL A 2 12	1.00%		43	
46	11	STORM SEW CL A 2 12	0.75%	9	-	
47	296	STORM SEW CL A 2 30	1.40%	662	-	
49	137	STORM SEW CL A 2 12	2.70%		26	
50	55	STORM SEW CL A 2 15	0.50%		15	
50A	45	STORM SEW CL A 2 15	0.50%		15	
51	137	STORM SEW CL A 2 12	0.50%		62	
52	18	STORM SEW CL A 2 15	0.50%	7	-	
52A	146	STORM SEW CL A 2 30	1.40%	139	-	
53	18	STORM SEW CL A 2 12	1.00%	6	-	
54	196	SS RG CL A 2 30	1.00%	164	-	
55	97	STORM SEW CL A 2 12	2.15%		23	
56	96	SS RG CL A 2 12	1.00%		29	
57	97	STORM SEW CL A 2 12	1.00%		23	
58	79	STORM SEW CL A 2 15	0.50%		30	
59	43	STORM SEW CL A 2 12	1.00%		12	
60	96	STORM SEW CL A 2 12	1.00%		26	
61	96	STORM SEW CL A 2 12	1.00%		25	
62	18	STORM SEW CL A 2 18	0.26%		8	
63	34	STORM SEW CL A 2 30	0.50%	30	-	
63A	8	STORM SEW CL A 2 30	0.35%	9	-	
				-	-	
64	15	P CUL CL A 1 18	1.67%	5	-	
				-	-	
66	15	P CUL CL A 1 18	1.67%	3	-	
				-	-	
101	86	STORM SEW CL A 1 12	0.44%		11	
103	95	STORM SEW CL A 2 12	0.50%		18	
104	85	STORM SEW CL A 1 12	0.44%		15	
105	60	STORM SEW CL A 2 15	0.44%		15	
106	48	STORM SEW CL A 2 15	0.44%		13	
107	86	STORM SEW CL A 1 12	0.44%		13	
108	11	STORM SEW CL A 1 18	0.30%	-	-	
109	83	STORM SEW CL A 2 18	0.30%	66	-	
110	97	STORM SEW CL A 2 12	1.00%		23	
111	10	STORM SEW CL A 2 12	1.00%	4	-	
112	190	STORM SEW CL A 2 18	0.30%	176	-	
113	13	STORM SEW CL A 2 12	1.00%	3	-	
114	128	STORM SEW CL A 2 24	0.30%	165	-	
115	92	STORM SEW CL A 2 12	2.00%		21	
116	27	STORM SEW CL A 2 12	1.60%		8	
116A	9	STORM SEW CL A 2 12	1.00%	3	-	

- * INDICATES PROPOSED STRUCTURE SHALL BE BACKFILLED WITH CLSM, SPECIAL.
- * EXISTING PIPE TO BE CONNECTED TO PROPOSED DRAINAGE STRUCTURE. THE CONTRACTOR SHALL VERIFY EXISTING INVERT PRIOR TO STRUCTURE FABRICATION.
- ** SEE IDOT STANDARD DETAIL 542311 TRAVERSABLE PIPE GRATE OR DRAINAGE DETAILS FOR SCHEDULE AND DETAILS OF CONCRETE END SECTIONS OR HEADWALLS THAT REQUIRE TRAVERSABLE PIPE GRATES.

FILE NAME : D:\60X10-sh-t-drain02-DrainageSchedule02.dgn

	USER NAME : dbarnes	DESIGNED REM	REVISED -	STATE OF ILLINOIS DEPARTMENT OF TRANSPORTATION	PROPOSED DRAINAGE SCHEDULES			F.A.I./P RTE.	SECTION	COUNTY	TOTAL SHEETS	SHEET NO.
	PLOT SCALE : 1:100	DRAWN DGB	REVISED -					*	(99-1HB-1) R-1	WILL	1508	557
	PLOT DATE : 9/21/2017	CHECKED PJO	REVISED -					CONTRACT NO. 60X10				
		DATE 11/15/17	REVISED -					* FAI 55, FAP 856 [ILLINOIS] FED. AID PROJECT				
				SCALE: AS SHOWN			SHEET NO. 2 OF 9 SHEETS		STA.		TO STA.	

STRUCTURE NUMBER	LOCATION			RIM ELEVATION	INVERT								STRUCTURE TYPE	COMMENTS
	ALIGNMENT	STATION	OFFSET		N	NE	E	SE	S	SW	W	NW		
117 *	NB WEBER RD	2817+97.0	101.8 LT	663.63	654.82		658.24			654.74			MAN TA 5 DIA T1F CL	
118 *	RAMP A	4999+18.8	14.5 RT	662.50		657.88		657.63		657.38			CB TA 4 DIA T8G	6 IN ADJUSTING RINGS TO BE USED
118A	RAMP A	4998+79.6	53.9 RT	662.18				658.11		658.11			CB TA 4 DIA T24F&G	
119 *	NB WEBER RD	2817+64.0	42.0 RT	664.94		659.20		659.00					CB TA 4 DIA T24F&G	
119A *	NB WEBER RD	2818+62.3	42.0 RT	663.69						659.71			INLETS TA T24F&G	
120 *	RAMP A	4999+68.2	46.9 LT	665.07		657.19			658.24		657.09	658.59	MAN TA 5 DIA T1F CL	
121 *	RAMP A	4998+42.5	31.6 RT	661.83								658.28	INLETS TA T24F&G	
122 *	RAMP A	4998+73.1	47.5 LT	662.82		657.97				659.12		657.87	CB TA 4 DIA T24F&G	
122A *	RAMP A	4998+43.2	30.8 LT	661.83						658.11			INLETS TA T24F&G	
122B *	RAMP A	4999+28.0	109.7 LT	665.64		661.52							INLETS TA T24F&G	
123 *	SB WEBER RD	1815+22.7	9.6 RT	669.49	659.09						662.59		MAN TA 4 DIA T1F CL	
124 *	SB WEBER RD	1813+78.0	0.0 LT	671.76	667.68								INLETS TA T24F&G	
124A *	SB WEBER RD	1814+57.1	0.0 LT	670.57	665.49				665.59				CB TA 4 DIA T24F&G	
124B *	SB WEBER RD	1815+22.7	0.0 LT	669.25			662.65		665.18		662.85		CB TA 4 DIA T24F&G	
125 *	SB WEBER RD	1813+46.5	56.0 LT	672.25	667.35								INLETS TA T24F&G	
125A *	SB WEBER RD	1814+55.2	53.7 LT	670.65	664.75				664.85				CB TA 4 DIA T24F&G	
125B *	SB WEBER RD	1815+28.2	48.8 LT	669.28	663.55		663.30		663.40				CB TA 4 DIA T24F&G	
126 *	SB WEBER RD	1816+13.0	43.4 LT	667.82					664.26				INLETS TA T24F&G	
129 *	NB WEBER RD	2813+19.5	0.5 LT	672.74	668.78								INLETS TA T24F&G	
130 *	NB WEBER RD	2813+86.2	8.0 LT	671.84	666.50				667.50				CB TA 4 DIA T24F&G	
131 *	NB WEBER RD	2815+24.5	23.2 LT	668.88					663.78			662.78	CB TA 4 DIA T24F&G	
132 *	RAMP D	9002+30.2	50.5 LT	665.62		659.00		661.00			659.00		CB TA 4 DIA T24F&G	
133	RAMP D	9001+17.8	9.6 RT	664.00						660.74			CB TA 4 DIA T8G	6 IN ADJUSTING RINGS TO BE USED
134 *	RAMP D	9001+41.0	0.4 LT	665.25		660.54	656.64			657.04		656.54	MAN TA 5 DIA T1F CL	
135	NB WEBER RD	2816+87.6	99.4 LT	665.12		654.43		656.35		654.35			MAN TA 5 DIA T1F CL	
136 *	RAMP D	9002+95.6	28.5 LT	663.14			659.32						INLETS TA T24F&G	
137	NB WEBER RD	2816+35.8	116.2 LT	665.82		654.19						654.11	MAN TA 7 DIA T1F CL	
138	NB WEBER RD	2816+47.2	136.6 LT	N/A				654.00					CONC ES 542001 30 1:4	** TRAVERSABLE PIPE GRATE: 15 FT
139	I-55 RAMP A	4994+00.0	46.0 RT	N/A					651.19				CONC ES 542001 30 1:6	** TRAVERSABLE PIPE GRATE: 26 FT
140	I-55 RAMP A	4994+00.0	58.0 LT	N/A	650.58								CONC ES 542001 30 1:6	** TRAVERSABLE PIPE GRATE: 26 FT
141	NB WEBER RD	2814+06.0	203.0 RT	N/A							647.00		CONC ES 542001 36 1:2	
141A	NB WEBER RD	2812+73.0	49.9 LT	N/A			645.95						CONC ES 542001 36 1:2	
142	I-55 RAMP B	6006+40.2	62.0 RT	N/A							646.89		CONC ES 542001 24 1:6	
142A	I-55 RAMP B	6006+42.0	47.6 LT	N/A			646.25						CONC ES 542001 24 1:6	
143	NB WEBER RD	2811+19.6	183.0 RT	N/A							644.68		CONC ES 542001 36 1:2	
143A	NB WEBER RD	2809+88.7	68.6 LT	N/A			642.97						CONC ES 542001 36 1:2	
144	I-55 RAMP D	9011+09.5	31.9 RT	N/A					643.61				SEE BCES DETAILS	** TRAVERSABLE PIPE GRATE: 13 FT
144A	I-55 RAMP D	9011+07.7	36.3 LT	N/A	643.22								SEE BCES DETAILS	** TRAVERSABLE PIPE GRATE: 13 FT
145	I-55 EXPWY	3099+09.0	71.0 LT	N/A					643.20				CONC ES 542001 36 1:3	** TRAVERSABLE PIPE GRATE: 13 FT
145A	I-55 EXPWY	3099+10.0	74.0 RT	N/A	642.61								CONC ES 542001 36 1:3	** TRAVERSABLE PIPE GRATE: 13 FT
146	I-55 EXPWY	3099+22.0	74.0 LT	N/A					644.07				SEE BCES DETAILS	** TRAVERSABLE PIPE GRATE: 18 FT
146A	I-55 EXPWY	3099+21.0	74.0 RT	N/A	643.90								SEE BCES DETAILS	** TRAVERSABLE PIPE GRATE: 18 FT
147	I-55 RAMP C	7993+88.0	45.0 LT	N/A					639.41				SEE BCES DETAILS	** TRAVERSABLE PIPE GRATE: 76 FT
148	I-55 RAMP C	7993+71.0	53.0 RT	N/A	639.21								SEE BCES DETAILS	** TRAVERSABLE PIPE GRATE: 112 FT
149	NORMANTOWN RD	91+95.0	53.0 LT	N/A					631.99				SEE BCES DETAILS	** TRAVERSABLE PIPE GRATE: 57 FT
150	NORMANTOWN RD	91+83.0	47.4 RT	N/A	631.31								SEE BCES DETAILS	** TRAVERSABLE PIPE GRATE: 57 FT
151	NORMANTOWN RD	94+78.4	28.8 LT	641.41	636.77				636.85				CB TA 4 DIA T24F&G	
152	NORMANTOWN RD	94+78.5	41.0 RT	641.29	637.14								INLETS TA T24F&G	
153	NORMANTOWN RD	94+78.4	43.9 LT	640.81					636.72		636.72		MAN TA 4 DIA T1F CL	

PIPE NUMBER	PIPE LENGTH (FOOT)	PIPE TYPE AND SIZE	PIPE SLOPE	TRENCH BACKFILL	CONTR LOWSTR MATL SPL	COMMENTS
				(CU YD)	(CU YD)	
117	105	STORM SEW CL A 2 24	0.30%	175	-	
118	74	STORM SEW CL A 2 18	0.26%	-	-	
118A	52	STORM SEW CL A 2 12	0.44%	11	-	
119	41	STORM SEW CL A 2 12	1.00%	17	-	
119A	102	STORM SEW CL A 2 12	0.50%		27	
120	150	STORM SEW CL A 2 18	0.30%		154	
121	40	STORM SEW CL A 1 12	0.44%		6	
122	73	STORM SEW CL A 2 15	0.33%		12	
122A	31	STORM SEW CL A 2 12	0.44%		7	
122B	80	STORM SEW CL A 1 12	3.00%		13	
123	171	STORM SEW CL A 2 15	0.50%		179	
124	76	STORM SEW CL A 2 12	2.75%		17	
124A	62	STORM SEW CL A 2 12	0.50%		14	
124B	6	STORM SEW CL A 2 15	1.00%		3	
125	111	STORM SEW CL A 2 12	2.25%		34	
125A	60	STORM SEW CL A 2 12	2.25%		22	
125B	45	STORM SEW CL A 2 15	1.00%		19	
126	71	STORM SEW CL A 2 12	1.00%		17	
129	64	STORM SEW CL A 1 12	2.00%		12	
130	136	STORM SEW CL A 2 12	2.00%		40	
131	89	STORM SEW CL A 2 12	2.00%		28	
132	98	STORM SEW CL A 2 12	2.00%		80	
133	20	STORM SEW CL A 1 12	1.00%	-	-	
134	38	STORM SEW CL A 2 18	0.50%		42	
135	52	STORM SEW CL A 2 30	0.30%	-	-	
136	65	STORM SEW CL A 2 12	0.50%	-	-	
137	22	STORM SEW CL A 2 30	0.50%	-	-	
139	105	P CUL CL A 1 30	0.58%	22	-	
141	190	STORM SEWERS JKD 36	0.37%	-	-	SEE DETAIL
	98	P CUL CL A 4 36		64	-	
142	110	P CUL CL A 1 24	0.58%	7	-	
143	191	STORM SEWERS JKD 36	0.60%	-	-	SEE DETAIL
	99	P CUL CL A 4 36		64	-	
147	98	PCBC 8X4	0.20%		-	
149	101	PCBC 10X5	0.67%		-	
151	11	STORM SEW CL A 2 12	0.44%	3	-	
152	67	STORM SEW CL A 2 12	0.44%	14	-	
153	154	STORM SEW CL A 2 12	1.00%	53	-	

- * INDICATES PROPOSED STRUCTURE SHALL BE BACKFILLED WITH CLSM, SPECIAL.
- * EXISTING PIPE TO BE CONNECTED TO PROPOSED DRAINAGE STRUCTURE. THE CONTRACTOR SHALL VERIFY EXISTING INVERT PRIOR TO STRUCTURE FABRICATION.
- ** SEE IDOT STANDARD DETAIL 542311 TRAVERSABLE PIPE GRATE OR DRAINAGE DETAILS FOR SCHEDULE AND DETAILS OF CONCRETE END SECTIONS OR HEADWALLS THAT REQUIRE TRAVERSABLE PIPE GRATES.

FILE NAME : D:\60X10-sh-t-drain03-DrainageSchedule.dgn



USER NAME : dbarnes
 PLOT SCALE : 1:100
 PLOT DATE : 9/21/2017

DESIGNED REM
 DRAWN DGB
 CHECKED PJO
 DATE 11/15/17

REVISED -
 REVISED -
 REVISED -
 REVISED -

**STATE OF ILLINOIS
 DEPARTMENT OF TRANSPORTATION**

PROPOSED DRAINAGE SCHEDULES

SCALE: AS SHOWN SHEET NO. 3 OF 9 SHEETS STA. TO STA.

F.A.I./P RTE.	SECTION	COUNTY	TOTAL SHEETS	SHEET NO.
*	(99-1HB-1) R-1	WILL	1508	558
CONTRACT NO. 60X10			* FAI 55, FAP 856 [ILLINOIS] FED. AID PROJECT	

STRUCTURE NUMBER	LOCATION			RIM ELEVATION	INVERT								STRUCTURE TYPE	COMMENTS
	ALIGNMENT	STATION	OFFSET		N	NE	E	SE	S	SW	W	NW		
154	NORMANTOWN RD	93+36.0	24.2 LT	640.20							635.21		INLETS TA T24F&G	
155	NORMANTOWN RD	93+06.0	23.3 LT	640.18			635.21						INLETS TA T24F&G	
156	NORMANTOWN RD	93+21.0	23.7 LT	640.18	635.07		635.15		635.15		635.15		CB TA 4 DIA T24F&G	
157	NORMANTOWN RD	93+06.0	35.2 RT	639.99			635.57						INLETS TA T24F&G	
158	NORMANTOWN RD	93+36.0	36.2 RT	640.01							635.57		INLETS TA T24F&G	
159	NORMANTOWN RD	93+21.0	35.7 RT	639.98	635.43		635.51				635.51		CB TA 4 DIA T24F&G	
160	NORMANTOWN RD	93+21.0	38.8 LT	639.61			635.18		635.01		634.93		MAN TA 4 DIA T1F CL	
161	NORMANTOWN RD	92+08.0	20.0 LT	640.83							636.80		CB TA 4 DIA T24F&G	
161A	NORMANTOWN RD	92+02.8	35.1 LT	641.10			634.36	636.66	634.16				MAN TA 6 DIA T1F CL	
162	NORMANTOWN RD	92+07.9	29.0 RT	640.66						635.41			CB TA 4 DIA T24F&G	
163	NORMANTOWN RD	91+94.4	33.5 RT	640.78	633.84	635.35			633.35				MAN TA 5 DIA T1F CL	
164	NORMANTOWN RD	91+91.0	61.7 RT	N/A	632.70								CONC ES 542001 18 1:3	
201 *	WEBER RD	836+35.3	106.4 RT	651.60							645.74		INLETS TA T24F&G	
202 *	WEBER RD	836+29.0	90.7 RT	651.35	645.47		645.67						CB TA 4 DIA T24F&G	
203A *	WEBER RD	837+28.0	88.8 RT	651.60			644.57*		645.00		644.57*	646.00	MAN TA 9 DIA T1F CL	
204 *	WEBER RD	835+20.0	63.0 RT	652.79							649.76		INLETS TB T24F&G	
205A	WEBER RD	835+05.0	6.0 LT	654.20	648.23								CB TA 4 DIA T8G	6 IN ADJUSTING RINGS TO BE USED
205B	WEBER RD	835+20.0	6.0 LT	654.08			649.09		648.13		647.13		MAN TA 4 DIA T1F CL	
206 *	WEBER RD	836+05.0	61.3 LT	652.33					647.26				INLETS TA T24F&G	
206A *	WEBER RD	835+33.0	51.0 LT	653.00	647.08			647.00					CB TA 4 DIA T24F&G	
207 *	WEBER RD	835+20.0	45.0 LT	653.24			646.97		646.89		646.97		MAN TA 4 DIA T1F CL	
209 *	WEBER RD	834+35.0	51.0 LT	653.62			648.59						CB TA 4 DIA T24F&G	
210 *	WEBER RD	834+35.0	45.0 LT	653.77	646.68				646.58		648.58		MAN TA 4 DIA T1F CL	
211 *	WEBER RD	834+36.0	63.0 RT	653.32					649.90				INLETS TA T24F&G	
212 *	WEBER RD	833+50.0	58.3 RT	653.98	649.07						648.07		CB TA 4 DIA T24F&G	
213 *	WEBER RD	833+50.0	51.0 LT	654.16			648.05						CB TA 4 DIA T24F&G	
214 *	WEBER RD	833+50.0	45.0 LT	654.31	646.37		647.57		646.27		648.04		MAN TA 4 DIA T1F CL	
215 *	WEBER RD	833+00.0	51.0 LT	654.48			648.56						CB TA 4 DIA T24F&G	
216 *	WEBER RD	833+00.0	45.0 LT	654.63	646.15				646.05		648.55		MAN TA 4 DIA T1F CL	
218 *	WEBER RD	832+46.0	52.0 RT	654.79					649.52				INLETS TA T24F&G	
219 *	WEBER RD	831+12.0	51.0 RT	655.67	648.87						648.77		CB TA 4 DIA T24F&G	
220	WEBER RD	831+12.0	0.0 LT	656.23			648.29				648.09		CB TA 4 DIA T8G	6 IN ADJUSTING RINGS TO BE USED
221 *	WEBER RD	831+12.0	51.0 LT	655.67			649.63						CB TA 4 DIA T24F&G	
222 *	WEBER RD	831+12.0	45.0 LT	655.82	645.58		647.69		644.62		649.62		MAN TA 6 DIA T1F CL	
222A *	WEBER RD	830+64.0	45.0 LT	656.12	644.50				644.50				MAN TA 6 DIA T1F CL	
223	WEBER RD	829+50.0	66.0 LT	656.10		651.08							INLETS TA T8G	
224 *	WEBER RD	829+78.0	51.0 LT	656.51			649.46				650.77		CB TC T24F&G	
225 *	WEBER RD	829+78.0	45.0 LT	656.67	644.42				644.42		649.42		MAN TA 7 DIA T1F CL	
226 *	WEBER RD	829+78.0	51.0 RT	656.52		650.38			650.28				CB TA 4 DIA T24F&G	
226A	WEBER RD	830+00.0	65.0 RT	654.67							650.61		INLETS TB T8G	
227 *	WEBER RD	828+44.0	51.0 RT	657.36	649.63						649.53		CB TA 5 DIA T24F&G	
228 *	WEBER RD	828+44.0	51.0 LT	657.36			651.24						CB TC T24F&G	
229 *	WEBER RD	828+44.0	45.0 LT	657.51	644.29		648.63		644.29		651.22		MAN TA 8 DIA T1F CL	
230 *	WEBER RD	827+10.0	51.0 LT	658.21			652.08				652.18		CB TC T24F&G	
231	WEBER RD	827+03.6	71.6 LT	657.10		652.37							INLETS TA T8G	
232 *	WEBER RD	827+10.0	45.0 LT	658.36	644.16				644.16		652.06		MAN TA 7 DIA T1F CL	

PIPE NUMBER	PIPE LENGTH (FOOT)	PIPE TYPE AND SIZE	PIPE SLOPE	TRENCH BACKFILL	CONTR LOWSTR MATL SPL	COMMENTS
				(CU YD)	(CU YD)	
154	12	STORM SEW CL A 2 12	0.50%	4	-	
155	12	STORM SEW CL A 2 12	0.50%	4	-	
156	11	STORM SEW CL A 2 15	0.50%	3	-	
157	12	STORM SEW WM REQ 12	0.50%	3	-	
158	12	STORM SEW WM REQ 12	0.50%	3	-	
159	56	STORM SEW CL A 2 15	0.50%	14	-	
160	114	STORM SEW CL A 2 15	0.50%	91	-	
161	14	STORM SEW CL A 2 12	1.00%	3	-	
161A	64	STORM SEW CL A 2 15	0.50%	48	-	
162	11	STORM SEW CL A 2 12	0.50%	-	-	
163	26	SS RG CL A 2 18	2.50%	-	-	
				-	-	
201	14	STORM SEW WM REQ 12	0.50%	5	-	
202	94	STORM SEW WM REQ 12	0.50%	38	-	
				-	-	
203A	7	STORM SEW CL A 2 42	0.44%		6	
204	67	STORM SEW CL A 1 12	1.00%		12	
				-	-	
205A	10	STORM SEW CL A 2 12	1.00%	-	-	
205B	35	STORM SEW CL A 2 12	0.44%		16	
206	69	STORM SEW CL A 2 18	0.26%		24	
206A	11	STORM SEW CL A 2 18	0.26%		5	
207	81	STORM SEW CL A 2 18	0.26%		40	
209	2	STORM SEW CL A 2 12	0.50%		1	
210	81	STORM SEW CL A 2 18	0.26%		72	
211	83	STORM SEW CL A 1 12	1.00%		16	
212	100	STORM SEW CL A 2 12	0.50%		41	
213	2	STORM SEW CL A 2 12	0.50%		1	
214	46	STORM SEW CL A 2 18	0.26%		47	
215	2	STORM SEW CL A 2 12	0.50%		1	
216	184	STORM SEW CL A 2 18	0.26%		226	
218	130	STORM SEW CL A 2 12	0.50%		50	
219	48	STORM SEW CL A 2 15	1.00%		41	
220	40	STORM SEW CL A 2 15	1.00%		39	
221	2	STORM SEW CL A 2 12	0.50%		1	
222	44	STORM SEW CL A 2 18	0.26%		70	
222A	82	STORM SEW CL A 2 48	0.10%		175	
223	31	STORM SEW CL A 2 12	1.00%	-	-	
224	2	STORM SEW CL A 2 12	2.00%		2	
225	130	STORM SEW CL A 2 48	0.10%	307	-	
226	131	STORM SEW CL A 2 24	0.50%		105	
226A	23	STORM SEW CL A 1 24	1.00%	-	-	
227	90	STORM SEW CL A 2 24	1.00%		98	
228	2	STORM SEW CL A 2 12	1.00%		1	
229	130	STORM SEW CL A 2 48	0.10%		344	
230	2	STORM SEW CL A 2 12	1.00%		1	
231	19	STORM SEW CL A 2 12	1.00%	-	-	
232	130	STORM SEW CL A 2 48	0.10%		351	

- * INDICATES PROPOSED STRUCTURE SHALL BE BACKFILLED WITH CLSM, SPECIAL.
- EXISTING PIPE TO BE CONNECTED TO PROPOSED DRAINAGE STRUCTURE. THE CONTRACTOR SHALL VERIFY EXISTING INVERT PRIOR TO STRUCTURE FABRICATION.
- ** SEE IDOT STANDARD DETAIL 542311 TRAVERSABLE PIPE GRATE OR DRAINAGE DETAILS FOR SCHEDULE AND DETAILS OF CONCRETE END SECTIONS OR HEADWALLS THAT REQUIRE TRAVERSABLE PIPE GRATES.

FILE NAME : D:\60X10-shr-drain04-DrainageSchedule.dwg

	USER NAME : dbarnes	DESIGNED REM	REVISED -	STATE OF ILLINOIS DEPARTMENT OF TRANSPORTATION	PROPOSED DRAINAGE SCHEDULES			F.A.I./P RTE.	SECTION	COUNTY	TOTAL SHEETS	SHEET NO.
	PLOT SCALE : 1:100	CHECKED PJO	REVISED -					*	(99-1HB-1) R-1	WILL	1508	559
	PLOT DATE : 6/14/2017	DATE 06/16/17	REVISED -					CONTRACT NO. 60X10				
	SCALE: AS SHOWN SHEET NO. 4 OF 9 SHEETS STA. TO STA.							* FAI 55, FAP 856 [ILLINOIS] FED. AID PROJECT				

STRUCTURE NUMBER	LOCATION			RIM ELEVATION	INVERT								STRUCTURE TYPE	COMMENTS
	ALIGNMENT	STATION	OFFSET		N	NE	E	SE	S	SW	W	NW		
233 *	WEBER RD	827+10.0	51.0 RT	658.21					653.03				INLETS TA T24F&G	
234 *	WEBER RD	825+76.0	51.0 RT	659.06	652.21						652.13		CB TA 4 DIA T24F&G	
235	WEBER RD	825+76.0	0.0 LT	659.63			651.19				649.19		CB TA 4 DIA T8G	6 IN ADJUSTING RINGS TO BE USED
236 *	WEBER RD	824+52.0	51.0 LT	659.84	649.00								INLETS TA T24F&G	
237 *	WEBER RD	825+76.0	51.0 LT	659.06			648.23	648.23			646.23		CB TA 4 DIA T24F&G	
238	WEBER RD	825+76.0	66.0 LT	657.64	644.03		646.03	644.03					MAN TA 7 DIA T1F CL	
239 *	WEBER RD	824+21.0	71.0 LT	657.58	643.88			643.88					MH TA 8D W/2 TIFCL RP	
240 *	WEBER RD	823+44.5	116.7 RT	659.33	654.07								INLETS TA T24F&G	
241 *	WEBER RD	823+91.7	116.4 RT	659.37				653.62			653.42		CB TA 4 DIA T24F&G	
243	WEBER RD	824+08.2	71.5 LT	657.65	643.86		641.20*				641.15*		MAN TA 9 DIA T1F CL	
301 *	WEBER RD	841+33.0	51.0 RT	652.69	648.39								INLETS TA T24F&G	
302 *	WEBER RD	843+13.0	51.0 RT	651.80	647.40			647.50					CB TA 4 DIA T24F&G	
303 *	WEBER RD	843+43.0	51.0 RT	651.80				647.40					INLETS TA T24F&G	
304 *	WEBER RD	843+28.0	51.0 RT	651.79	647.29			647.29			646.79		CB TA 4 DIA T24F&G	
305	WEBER RD	843+28.0	2.0 LT	653.38			646.29				646.19		CB TA 4 DIA T8G	6 IN ADJUSTING RINGS TO BE USED
306 *	WEBER RD	843+43.0	51.0 LT	651.80				646.88					INLETS TA T24F&G	
307 *	WEBER RD	843+12.0	51.0 LT	651.80	646.56			646.66					CB TA 4 DIA T24F&G	
308 *	WEBER RD	843+28.0	51.0 LT	651.79	646.76		645.84	646.44			645.84		CB TA 5 DIA T24F&G	
309 *	WEBER RD	841+92.0	51.0 LT	652.32	647.83								INLETS TA T24F&G	
312	WEBER RD	843+28.7	67.7 LT	649.58			645.88						CB TA 4 DIA T8G	6 IN ADJUSTING RINGS TO BE USED
313 *	WEBER RD	843+28.0	45.0 LT	651.94	645.30		645.80				645.80		MAN TA 5 DIA T1F CL	
314 *	WEBER RD	844+14.0	51.0 LT	652.00	647.44								INLETS TA T24F&G	
316 *	WEBER RD	844+79.0	51.0 LT	652.26			646.93	647.13					CB TA 4 DIA T24F&G	
317 *	WEBER RD	844+79.0	45.0 LT	652.41	644.91			645.01			646.91		MAN TA 5 DIA T1F CL	
318	WEBER RD	841+60.7	79.3 RT	N/A	649.10								CONC ES 542001 24 1:4	
319	WEBER RD	842+39.7	79.0 RT	N/A					648.90				CONC ES 542001 24 1:4	
320 *	WEBER RD	844+13.0	51.0 RT	652.00			648.57						INLETS TA T24F&G	
321	WEBER RD	844+13.0	67.6 RT	N/A							648.49		CONC ES 542001 15 1:3	
322 *	WEBER RD	844+79.0	51.0 RT	652.26			648.49						INLETS TA T24F&G	
323	WEBER RD	844+79.0	66.4 RT	N/A							648.36		CONC ES 542001 15 1:3	
324	WEBER RD	845+82.0	69.2 RT	N/A							648.16		CONC ES 542001 24 1:4	
325 *	WEBER RD	845+82.0	51.0 RT	652.67			648.09				647.75		CB TA 4 DIA T24F&G	
326 *	WEBER RD	845+82.0	0.0 LT	653.25			647.52				647.32		CB TA 4 DIA T8G	6 IN ADJUSTING RINGS TO BE USED
327 *	WEBER RD	845+82.0	51.0 LT	652.67			647.63						CB TC T24F&G	
328 *	WEBER RD	845+82.0	45.0 LT	652.82	644.62		647.12		644.72		647.62		MAN TA 7 DIA T1F CL	
329 *	WEBER RD	849+94.0	51.0 RT	654.30			650.44						INLETS TA T24F&G	
330	WEBER RD	849+94.0	71.0 RT	N/A							650.26		CONC ES 542001 15 1:4	
331 *	WEBER RD	848+92.0	51.0 RT	653.90			649.94						INLETS TA T24F&G	
332	WEBER RD	848+92.0	72.4 RT	N/A							649.75		CONC ES 542001 15 1:4	
333 *	WEBER RD	847+87.0	51.0 RT	653.48			648.92						INLETS TA T24F&G	
334	WEBER RD	847+87.0	70.0 RT	N/A							648.75		CONC ES 542001 15 1:4	
335	WEBER RD	846+85.0	72.0 RT	N/A							647.99		CONC ES 542001 24 1:4	
336 *	WEBER RD	846+85.0	51.0 RT	653.07			647.78				647.70		CB TA 4 DIA T24F&G	
338 *	WEBER RD	846+85.0	45.0 LT	653.22	644.22		646.45		644.42				MAN TA 7 DIA T1F CL	
339 *	WEBER RD	848+61.0	63.0 LT	653.47	649.64								INLETS TA T24F&G	
341 *	WEBER RD	849+18.0	63.0 LT	653.70	649.30				649.40				INLETS TB T24F&G	
342 *	WEBER RD	849+98.0	63.0 LT	654.02			646.96		648.96				INLETS TB T24F&G	
343 *	WEBER RD	849+98.0	45.0 LT	654.47	643.91				643.91		646.90		MAN TA 7 DIA T1F CL	

PIPE NUMBER	PIPE LENGTH (FOOT)	PIPE TYPE AND SIZE	PIPE SLOPE	TRENCH BACKFILL	CONTR LOWSTR MATL SPL	COMMENTS
				(CU YD)	(CU YD)	
233	131	STORM SEW CL A 2 12	0.63%		50	
234	47	STORM SEW CL A 2 15	2.00%		42	
235	48	STORM SEW CL A 2 15	2.00%		67	
236	123	STORM SEW CL A 2 12	0.63%		168	
237	10	STORM SEW CL A 3 15	2.00%	17	-	
238	151	STORM SEW CL A 2 48	0.10%	-	-	
239	7	STORM SEW CL A 3 36	0.25%	-	-	
240	45	STORM SEW CL A 2 12	1.00%	15	-	
241	42	STORM SEW CL A 2 12	1.00%	18	-	
243	14	STORM SEW CL A 3 48	0.36%	-	-	
301	177	STORM SEW CL A 2 12	0.50%		35	
302	11	STORM SEW CL A 2 12	1.00%		3	
303	11	STORM SEW CL A 2 12	1.00%		3	
304	50	STORM SEW CL A 2 18	1.00%		21	
305	39	STORM SEW CL A 2 18	1.00%		19	
306	12	STORM SEW CL A 2 12	1.00%		4	
307	12	STORM SEW CL A 2 12	1.00%		4	
308	4	STORM SEW CL A 2 18	1.00%		2	
309	117	STORM SEW CL A 2 12	1.00%		30	
				-	-	
312	12	STORM SEW CL A 2 15	0.33%			
313	145	STORM SEW CL A 2 30	0.20%		118	
314	62	STORM SEW CL A 2 12	0.50%		16	
316	4	STORM SEW CL A 2 12	0.50%		2	
317	98	STORM SEW CL A 2 30	0.20%		97	
318	80	P CUL CL A 1 EQRS 24	0.25%	6	-	
				-	-	
320	15	STORM SEW CL A 1 15	0.50%	2	-	
				-	-	
322	13	STORM SEW CL A 1 15	1.00%	2	-	
				-	-	
324	14	STORM SEW CL A 1 24	0.50%	2	-	
325	47	STORM SEW CL A 2 24	0.50%		15	
326	40	STORM SEW CL A 2 24	0.50%		16	
327	3	STORM SEW CL A 2 12	0.50%		1	
328	98	STORM SEW CL A 2 30	0.20%		113	
329	18	STORM SEW CL A 1 15	1.00%	1	-	
				-	-	
331	19	STORM SEW CL A 1 15	1.00%	2	-	
				-	-	
333	17	STORM SEW CL A 1 15	1.00%	3	-	
				-	-	
335	17	STORM SEW CL A 1 24	1.24%	3	-	
336	91	STORM SEW CL A 2 24	1.37%		39	
338	306	STORM SEW CL A 2 54	0.10%		455	
339	54	STORM SEW WM REQ 12	0.44%		10	
341	77	STORM SEW WM REQ 12	0.44%		19	
342	13	STORM SEW CL A 2 15	0.44%		11	
343	435	STORM SEW CL A 2 54	0.10%		715	

- * INDICATES PROPOSED STRUCTURE SHALL BE BACKFILLED WITH CLSM, SPECIAL.
- * EXISTING PIPE TO BE CONNECTED TO PROPOSED DRAINAGE STRUCTURE. THE CONTRACTOR SHALL VERIFY EXISTING INVERT PRIOR TO STRUCTURE FABRICATION.
- ** SEE IDOT STANDARD DETAIL 542311 TRAVERSABLE PIPE GRATE OR DRAINAGE DETAILS FOR SCHEDULE AND DETAILS OF CONCRETE END SECTIONS OR HEADWALLS THAT REQUIRE TRAVERSABLE PIPE GRATES.

FILE NAME : D:\60X10-shr-drain05-DrainageSchedule05.dgn

	USER NAME : dbarnes	DESIGNED REM	REVISED -	STATE OF ILLINOIS DEPARTMENT OF TRANSPORTATION	PROPOSED DRAINAGE SCHEDULES			F.A.I./P RTE.	SECTION	COUNTY	TOTAL SHEETS	SHEET NO.
	PLOT SCALE : 1:100	DRAWN DGB	REVISED -					*	(99-1HB-1) R-1	WILL	1508	560
	PLOT DATE : 6/14/2017	CHECKED PJO	REVISED -					CONTRACT NO. 60X10				
		DATE 06/16/17	REVISED -					* FAI 55, FAP 856 ILLINOIS FED. AID PROJECT				
				SCALE: AS SHOWN			SHEET NO. 5 OF 9 SHEETS		STA. TO STA.			

STRUCTURE NUMBER	LOCATION			RIM ELEVATION	INVERT								STRUCTURE TYPE	COMMENTS
	ALIGNMENT	STATION	OFFSET		N	NE	E	SE	S	SW	W	NW		
344 *	WEBER RD	853+37.0	51.0 LT	653.74	648.64				648.74				CB TA 4 DIA T24F&G	
344A	WEBER RD	852+70.0	79.0 LT	652.00	649.10								CB TC T8G	
345 *	WEBER RD	854+41.0	9.0 LT	654.09							649.07		CB TA 4 DIA T11V F&G	
346 *	WEBER RD	854+41.0	51.0 LT	653.31			646.99	648.13					CB TC T24F&G	
347 *	WEBER RD	854+41.0	45.0 LT	653.46	643.47		648.77	643.47		646.97			MAN TA 7 DIA T1F CL	
348 *	WEBER RD	852+06.0	51.0 RT	654.28			650.67						INLETS TA T24F&G	
349	WEBER RD	852+06.0	70.0 RT	N/A						650.50			CONC ES 542001 15 1:4	
350 *	WEBER RD	852+90.0	52.0 RT	653.91			650.26						INLETS TA T24F&G	
351	WEBER RD	852+89.9	71.5 RT	N/A						650.08			CONC ES 542001 15 1:4	
352 *	WEBER RD	853+67.2	56.7 RT	653.47			649.87						INLETS TA T24F&G	
353	WEBER RD	853+67.3	75.7 RT	N/A						649.70			CONC ES 542001 15 1:4	
354 *	WEBER RD	854+41.2	61.1 RT	653.06			649.49						INLETS TA T24F&G	
355	WEBER RD	854+41.2	79.2 RT	N/A						649.33			CONC ES 542001 15 1:3	
356	WEBER RD	855+00.0	78.0 RT	N/A						649.03			CONC ES 542001 24 1:3	
357 *	WEBER RD	855+00.0	63.0 RT	652.77	646.98		648.98						CB TA 5 DIA T24F&G	
358 *	WEBER RD	855+95.0	63.0 RT	652.42	646.54			646.64					CB TA 5 DIA T24F&G	
359 *	WEBER RD	855+45.0	51.0 LT	652.88	648.18								INLETS TA T24F&G	
360 *	WEBER RD	856+10.0	9.0 LT	653.53			645.67			645.59			CB TA 5 DIA T11V F&G	
361 *	WEBER RD	856+10.0	54.3 LT	652.67			646.57	647.57		647.57			CB TA 4 DIA T24F&G	
361A *	WEBER RD	856+10.0	72.5 LT	652.00			647.75						INLETS TA T1F OL	
362 *	WEBER RD	856+10.0	45.0 LT	652.90			645.30	643.30		646.54	643.30		MAN TA 9 DIA T1F CL	
363 *	WEBER RD	856+10.0	63.0 RT	652.45			646.95	646.45		646.35			CB TA 5 DIA T24F&G	
364 *	WEBER RD	866+22.0	31.5 LT	656.96	648.62			648.62					CB TA 4 DIA T24F&G	
365 *	WEBER RD	866+22.0	33.0 RT	656.93				652.51					INLETS TA T24F&G	
366 *	WEBER RD	865+04.0	34.3 LT	656.49	648.12		648.04						CB TA 4 DIA T24F&G	
367 *	WEBER RD	865+04.0	37.2 RT	656.39	651.37					651.27			CB TA 4 DIA T24F&G	
368 *	WEBER RD	865+04.0	28.5 LT	656.61			650.66	647.96		648.02			MAN TA 4 DIA T1F CL	
369 *	WEBER RD	863+86.0	38.8 LT	656.02			647.72						CB TA 4 DIA T24F&G	
370 *	WEBER RD	863+86.0	41.2 RT	655.87						650.70			CB TA 4 DIA T24F&G	
371 *	WEBER RD	863+86.0	32.8 LT	656.14	647.58		650.00	647.50		647.71			MAN TA 4 DIA T1F CL	
371A *	WEBER RD	863+00.0	36.6 LT	655.78	647.22			647.14		647.34			MAN TA 4 DIA T1F CL	
372 *	WEBER RD	862+68.0	44.0 LT	655.50			647.99						CB TA 4 DIA T24F&G	
373 *	WEBER RD	862+68.0	45.0 RT	655.33						650.17			CB TA 4 DIA T24F&G	
374 *	WEBER RD	862+68.0	38.0 LT	655.63	647.04		649.36	646.96		647.97			MAN TA 4 DIA T1F CL	
375 *	WEBER RD	861+50.0	51.5 LT	654.77			647.62						CB TA 4 DIA T24F&G	
376	WEBER RD	861+50.0	6.0 RT	655.85			650.06			649.06			CB TA 4 DIA T8G	6 IN ADJUSTING RINGS TO BE USED
377 *	WEBER RD	861+50.0	49.3 RT	654.80						650.46			INLETS TA T24F&G	
378 *	WEBER RD	861+50.0	45.6 LT	654.92	646.67		648.59	646.59		647.60			MAN TA 4 DIA T1F CL	
379 *	WEBER RD	860+98.0	55.0 LT	654.47				648.50					INLETS TA T24F&G	
380 *	WEBER RD	860+46.0	59.3 LT	654.16	648.25		647.25						CB TA 4 DIA T24F&G	
380A *	WEBER RD	871+20.5	0.7 RT	657.59	653.91								CB TA 4 DIA T8G	6 IN ADJUSTING RINGS TO BE USED
381 *	WEBER RD	860+46.0	51.0 RT	654.36				648.74		647.74			CB TA 4 DIA T24F&G	
381A *	WEBER RD	871+40.0	0.8 RT	657.80			653.73*	653.83		653.76*			MAN TA 4 DIA T1F CL	
382 *	WEBER RD	860+46.0	53.2 LT	654.31	646.32		647.24	646.24		647.24			MAN TA 5 DIA T1F CL	
383 *	WEBER RD	859+43.0	51.0 RT	653.95	649.24								INLETS TA T24F&G	
384 *	WEBER RD	859+75.0	57.0 LT	653.92	646.13			646.05		647.05			MAN TA 5 DIA T1F CL	
385 *	WEBER RD	859+75.0	63.0 LT	653.77			647.06						CB TA 4 DIA T24F&G	
386 *	WEBER RD	859+10.0	63.0 LT	653.51				647.77					INLETS TA T24F&G	

PIPE NUMBER	PIPE LENGTH (FOOT)	PIPE TYPE AND SIZE	PIPE SLOPE	TRENCH BACKFILL	CONTR LOWSTR MATL SPL	COMMENTS
				(CU YD)	(CU YD)	
344	102	STORM SEW CL A 2 12	0.50%		30	
344A	73	STORM SEW CL A 1 12	0.50%	4	-	
345	30	STORM SEW CL A 2 12	1.00%		8	
346	2	STORM SEW CL A 2 12	1.00%		1	
347	161	STORM SEW CL A 2 54	0.10%		240	
348	17	STORM SEW CL A 1 15	1.00%	1	-	
				-	-	
350	18	STORM SEW CL A 1 15	1.00%	1	-	
				-	-	
352	17	STORM SEW CL A 1 15	1.00%	1	-	
				-	-	
354	16	STORM SEW CL A 1 15	1.00%	1	-	
				-	-	
356	11	STORM SEW CL A 1 24	0.45%	1	-	
357	90	STORM SEW CL A 2 24	0.37%		35	
358	9	STORM SEW CL A 2 24	1.00%		4	
359	61	STORM SEW WM REQ 15	1.00%		17	
360	29	STORM SEW CL A 2 24	1.00%		28	
361	3	STORM SEW CL A 2 15	1.00%		2	
361A	18	STORM SEW CL A 2 12	1.00%	5	-	
362	116	SS RG CL A 2 54	0.10%		168	
363	68	STORM SEW CL A 2 24	1.00%		55	
364	115	STORM SEW CL A 2 12	0.44%		111	
365	114	STORM SEW CL A 2 12	1.00%		28	
366	2	STORM SEW CL A 2 12	1.00%		2	
367	61	STORM SEW CL A 2 12	1.00%		20	
368	114	STORM SEW CL A 2 15	0.33%		119	
369	2	STORM SEW CL A 2 12	0.50%		2	
370	70	STORM SEW CL A 2 12	1.00%		24	
371	85	STORM SEW CL A 2 15	0.33%			
371A	29	STORM SEW CL A 2 15	0.33%		31	
371B	23	STORM SEW CL A 2 12	0.50%	17	-	
372	2	STORM SEW CL A 2 12	1.00%		2	
373	81	STORM SEW CL A 2 12	1.00%		28	
374	114	STORM SEW CL A 2 18	0.26%			
375	2	STORM SEW CL A 2 12	1.00%		2	
376	47	STORM SEW CL A 2 12	1.00%		21	
377	40	STORM SEW CL A 2 12	1.00%		12	
378	101	STORM SEW CL A 2 18	0.26%			
379	49	STORM SEW WM REQ 12	0.50%		19	
380	2	STORM SEW CL A 2 12	0.50%		2	
380A	15	STORM SEW CL A 1 12	0.50%	3	-	
381	100	STORM SEW CL A 2 12	0.50%		47	
				-	-	
382	66	STORM SEW CL A 2 24	0.18%			
383	100	STORM SEW CL A 2 12	0.50%		29	
384	130	SS RG CL A 2 24	0.75%			
385	2	STORM SEW CL A 2 12	0.50%		1	
386	66	STORM SEW WM REQ 12	1.00%		25	

- * INDICATES PROPOSED STRUCTURE SHALL BE BACKFILLED WITH CLSM, SPECIAL.
- * EXISTING PIPE TO BE CONNECTED TO PROPOSED DRAINAGE STRUCTURE. THE CONTRACTOR SHALL VERIFY EXISTING INVERT PRIOR TO STRUCTURE FABRICATION.
- ** SEE IDOT STANDARD DETAIL 542311 TRAVERSABLE PIPE GRATE OR DRAINAGE DETAILS FOR SCHEDULE AND DETAILS OF CONCRETE END SECTIONS OR HEADWALLS THAT REQUIRE TRAVERSABLE PIPE GRATES.

FILE NAME : D:\60X10-sh-t-dra-06-DrainageSchedule.dwg

	USER NAME : dbarnes	DESIGNED REM	REVISED -	STATE OF ILLINOIS DEPARTMENT OF TRANSPORTATION	PROPOSED DRAINAGE SCHEDULES			F.A.I./P RTE.	SECTION	COUNTY	TOTAL SHEETS	SHEET NO.
	PLOT SCALE : 1:100	CHECKED PJO	REVISED -					*	(99-IHB-1) R-1	WILL	1508	561
	PLOT DATE : 6/14/2017	DATE 06/16/17	REVISED -					CONTRACT NO. 60X10				
								* FAI 55, FAP 856 [ILLINOIS] FED. AID PROJECT				
				SCALE: AS SHOWN			SHEET NO. 6 OF 9 SHEETS		STA.		TO STA.	

STRUCTURE NUMBER	LOCATION			RIM ELEVATION	INVERT								STRUCTURE TYPE	COMMENTS
	ALIGNMENT	STATION	OFFSET		N	NE	E	SE	S	SW	W	NW		
387 *	WEBER RD	858+40.0	63.0 LT	653.24	647.11		647.01						CB TA 4 DIA T24F&G	
388 *	WEBER RD	858+40.0	57.0 LT	653.39	645.07		645.07			644.99	646.99		MAN TA 5 DIA T1F CL	
390 *	WEBER RD	858+25.0	59.6 RT	653.31		648.21							CB TA 4 DIA T24F&G	
391 *	WEBER RD	857+92.3	71.0 RT	652.94				647.79					INLETS TA T24F&G	
392 *	WEBER RD	857+72.6	87.8 RT	652.64	647.46						647.56		CB TA 4 DIA T24F&G	
393	WEBER RD	858+21.5	96.4 RT	656.21	650.21*				647.00		646.75		MAN TA 4 DIA T1F CL	
394 *	WEBER RD	858+40.0	65.0 RT	654.01				646.58		648.09	646.25		MAN TA 4 DIA T1F CL	
395 *	WEBER RD	856+90.4	87.8 RT	652.61					647.86				INLETS TA T24F&G	
396 *	WEBER RD	856+76.2	72.4 RT	652.68		647.68			647.58				CB TA 4 DIA T24F&G	
400 *	WEBER RD	857+29.7	82.4 LT	652.89		644.19		643.19			643.19	645.19	MAN TA 9 DIA T1F CL	
401 *	WEBER RD	856+83.8	84.3 LT	652.13							647.58		INLETS TA T24F&G	
402 *	WEBER RD	856+89.7	90.1 LT	652.20				647.53			645.53		CB TA 4 DIA T24F&G	
403 *	WEBER RD	857+74.0	126.0 LT	652.16			647.50						INLETS TA T24F&G	
404 *	WEBER RD	857+77.9	111.3 LT	652.10				645.44			647.44		CB TA 4 DIA T24F&G	
405 *	WEBER RD	857+29.6	98.9 LT	652.97			643.18	645.18			643.18		MH TA 9D W/2 TIFCL RP	
406 *	RODEO DR	496+34.2	3.0 LT	652.85		646.12*	642.93				642.82*		MAN TA 9 DIA T1F CL	
406A	RODEO DR	497+13.1	1.6 LT	652.84			643.00		643.00		643.00		MAN TA 9 DIA T1F CL	
406B	RODEO DR	497+12.4	37.6 RT	652.72	643.06				EX 54"		EX 12"		MAN TA 8 DIA T1F CL	
407	REMINGTON BLVD	504+09.4	18.8 LT	654.07			EX 12"						CB TA 4 DIA T11V F&G	
501	NORMANTOWN RD	101+55.0	36.0 LT	638.10			633.62						INLETS TA T24F&G	
502	NORMANTOWN RD	102+57.0	36.0 LT	636.69			632.56				632.64		CB TA 4 DIA T24F&G	
503	NORMANTOWN RD	103+92.0	36.0 LT	636.21					631.91		631.99		CB TA 4 DIA T24F&G	
504	NORMANTOWN RD	103+92.0	12.0 RT	636.69	631.72				631.64				CB TA 4 DIA T11V F&G	
505	NORMANTOWN RD	103+92.0	42.0 RT	636.21	631.52				631.44				CB TA 4 DIA T24F&G	
506	NORMANTOWN RD	103+92.0	51.0 RT	636.43	631.42		631.34						MAN TA 4 DIA T1F CL	
507	NORMANTOWN RD	106+08.0	36.0 LT	635.60			631.33						INLETS TA T24F&G	
508	NORMANTOWN RD	106+39.0	36.0 LT	635.59							631.33		INLETS TA T24F&G	
509	NORMANTOWN RD	106+23.0	36.0 LT	635.59			631.27	631.02		631.27			CB TA 4 DIA T24F&G	
510	NORMANTOWN RD	106+01.0	10.0 RT	636.11			631.86						INLETS TA T11V F&G	
511	NORMANTOWN RD	106+23.0	8.0 RT	636.05	630.86				630.78		631.78		CB TA 4 DIA T11V F&G	
512	NORMANTOWN RD	106+48.0	13.0 RT	636.09							631.87		INLETS TA T11V F&G	
513	NORMANTOWN RD	106+23.0	16.0 RT	636.05	630.76		631.77	630.68					CB TA 4 DIA T11V F&G	
514	NORMANTOWN RD	105+68.0	42.0 RT	635.68			631.65						INLETS TA T24F&G	
515	NORMANTOWN RD	105+83.0	42.0 RT	635.64					630.76		631.59		CB TA 4 DIA T24F&G	
516	NORMANTOWN RD	105+83.0	51.0 RT	635.77	630.74		630.66				630.74		MAN TA 4 DIA T1F CL	
517	NORMANTOWN RD	106+22.0	51.0 RT	635.78	630.55		630.47				630.55		MAN TA 5 DIA T1F CL	
518A	NORMANTOWN RD	106+50.0	62.0 LT	634.70							632.32		PRC FLAR END SEC 24	
519	NORMANTOWN RD	107+49.0	36.0 LT	635.60					631.44				INLETS TA T24F&G	
520	NORMANTOWN RD	107+49.0	5.0 RT	636.51	631.27		630.80*						CB TA 4 DIA T11V F&G	
521	NORMANTOWN RD	108+08.3	53.4 RT	635.59				629.90*			630.00	629.88*	MAN TA 6 DIA T1F CL	
522	NORMANTOWN RD	109+25.0	0.0 LT	636.82	632.15								INLETS TA T11V F&G	
523	NORMANTOWN RD	109+25.0	35.7 LT	636.10	631.66				631.74				CB TA 4 DIA T11V F&G	
524	NORMANTOWN RD	109+25.0	54.0 LT	N/A					631.50				CONC ES 542001 15 1:3	
601 *	WEBER RD	839+22.0	63.0 LT	652.24					648.39				INLETS TA T24F&G	
602 *	WEBER RD	838+48.0	63.0 LT	651.85	647.90				647.70				CB TA 4 DIA T24F&G	
603 *	WEBER RD	837+73.7	64.8 LT	651.56	647.21					647.11			CB TA 4 DIA T24F&G	
604 *	WEBER RD	837+41.6	88.2 LT	651.06		646.86					646.76		CB TA 4 DIA T24F&G	
605 *	WEBER RD	837+35.7	100.5 LT	650.95			646.69				646.61		CB TA 4 DIA T24F&G	

PIPE NUMBER	PIPE LENGTH (FOOT)	PIPE TYPE AND SIZE	PIPE SLOPE	TRENCH BACKFILL	CONTR LOWSTR MATL SPL	COMMENTS
				(CU YD)	(CU YD)	
387	2	STORM SEW CL A 2 12	1.00%		1	
388	107	SS RG CL A 2 24	0.75%		120	
390	12	STORM SEW CL A 2 12	1.00%	4	-	
391	23	STORM SEW CL A 2 12	1.00%	7	-	
392	46	SS RG CL A 2 15	1.00%	-	-	
393	33	SS RG CL A 2 15	0.50%	42	-	
394	118	STORM SEW CL A 2 18	1.00%		115	
395	18	STORM SEW CL A 2 12	1.00%		5	
396	63	STORM SEW CL A 2 12	1.00%		19	
400	8	STORM SEW CL A 2 54	0.10%		12	
401	5	STORM SEW CL A 2 12	1.00%		2	
402	35	STORM SEW CL A 2 12	1.00%		28	
403	12	STORM SEW CL A 2 12	0.50%		3	
404	51	SS RG CL A 2 12	0.50%		40	
405	180	STORM SEW CL A 2 42	0.10%		268	
				-	-	
406A	70	STORM SEW CL A 2 54	0.10%		105	
406B	36	STORM SEW CL A 2 54	0.20%		46	
				-	-	
501	98	STORM SEW CL A 2 12	1.00%	19	-	
502	130	SS RG CL A 2 12	0.44%	24	-	
503	43	STORM SEW CL A 2 15	0.44%	10	-	
504	28	STORM SEW CL A 2 15	0.44%	8	-	
505	5	STORM SEW CL A 2 15	0.44%	2	-	
506	187	STORM SEW WM REQ 18	0.32%	-	-	
507	12	STORM SEW CL A 2 12	0.44%	3	-	
508	13	STORM SEW CL A 2 12	0.44%	3	-	
509	38	STORM SEW CL A 2 12	0.44%	10	-	
510	19	STORM SEW CL A 2 12	0.44%	4	-	
511	3	STORM SEW CL A 2 12	0.44%	1	-	
512	23	STORM SEW CL A 2 12	0.44%	5	-	
513	31	STORM SEW CL A 2 15	0.44%	10	-	
514	13	STORM SEW CL A 1 12	0.44%	3	-	
515	5	STORM SEW CL A 2 12	0.44%	2	-	
516	35	STORM SEW CL A 2 18	0.32%	-	-	
517	187	STORM SEW CL A 2 24	0.25%	86	-	
518	85	STORM SEW CL A 1 24	0.25%	23	-	
				-	-	
519	38	STORM SEW CL A 2 15	0.44%	9	-	
				-	-	
522	41	STORM SEW CL A 2 15	1.00%	9	-	
523	16	STORM SEW CL A 1 15	1.00%	3	-	
				-	-	
601	71	STORM SEW CL A 1 12	0.70%		11	
602	70	STORM SEW CL A 1 15	0.70%		14	
603	35	SS RG CL A 1 15	0.70%		7	
604	11	STORM SEW CL A 1 18	0.70%	3	-	
605	15	STORM SEW CL A 1 18	0.70%	4	-	

- * INDICATES PROPOSED STRUCTURE SHALL BE BACKFILLED WITH CLSM, SPECIAL.
- * EXISTING PIPE TO BE CONNECTED TO PROPOSED DRAINAGE STRUCTURE. THE CONTRACTOR SHALL VERIFY EXISTING INVERT PRIOR TO STRUCTURE FABRICATION.
- ** SEE IDOT STANDARD DETAIL 542311 TRAVERSABLE PIPE GRATE OR DRAINAGE DETAILS FOR SCHEDULE AND DETAILS OF CONCRETE END SECTIONS OR HEADWALLS THAT REQUIRE TRAVERSABLE PIPE GRATES.

FILE NAME : D:\60X10-sh-t-drain07-DrainageSchedule.dwg

	USER NAME : dbarnes	DESIGNED REM	REVISED -	STATE OF ILLINOIS DEPARTMENT OF TRANSPORTATION	PROPOSED DRAINAGE SCHEDULES			F.A.I./P RTE.	SECTION	COUNTY	TOTAL SHEETS	SHEET NO.
	PLOT SCALE : 1:100	DRAWN DGB	REVISED -					*	(99-1HB-1) R-1	WILL	1508	562
	PLOT DATE : 9/21/2017	CHECKED PJO	REVISED -					CONTRACT NO. 60X10				
		DATE 11/15/17	REVISED -					* FAI 55, FAP 856 ILLINOIS FED. AID PROJECT				
				SCALE: AS SHOWN			SHEET NO. 7 OF 9 SHEETS		STA. TO STA.			

STRUCTURE NUMBER	LOCATION			RIM ELEVATION	INVERT								STRUCTURE TYPE	COMMENTS
	ALIGNMENT	STATION	OFFSET		N	NE	E	SE	S	SW	W	NW		
606 *	WEBER RD	836+44.8	91.1 LT	651.50							647.33		INLETS TA T24F&G	
607	WEBER RD	836+35.5	119.2 LT	651.00	647.48									PIPE COLLAR; SEE DETAIL
608 *	WEBER RD	836+50.8	116.9 LT	651.35	647.02		647.22		647.12				CB TA 4 DIA T24F&G	
609 *	WEBER RD	837+42.5	115.0 LT	651.27	649.08*		646.50		646.50		646.41*		MAN TA 6 DIA T1F CL	
650	WINDHAM PKWY	307+54.0	18.1 RT	655.62	650.00								INLETS TA T11V F&G	
651	WINDHAM PKWY	307+54.0	18.0 LT	655.62	649.65				649.65				CB TA 4 DIA T11V F&G	
652	WINDHAM PKWY	307+53.0	29.6 LT	655.97			648.96*		649.55		648.93*		MAN TA 5 DIA T1F CL	
653	WINDHAM PKWY	305+98.0	26.0 RT	654.77	648.52				648.54*				CB TA 4 DIA T11V F&G	
653A	WINDHAM PKWY	305+98.0	19.0 RT	654.92					648.47					PIPE COLLAR; SEE DETAIL
654	WINDHAM PKWY	305+98.0	19.3 LT	654.91	648.12				648.12*				CB TA 4 DIA T11V F&G	
656	WINDHAM PKWY	304+48.2	32.5 RT	653.16	649.00								CB TA 4 DIA T11V F&G	
657	WINDHAM PKWY	304+48.2	28.2 LT	653.24			647.54*		648.00		647.52*		MAN TA 6 DIA T1F CL	
658	WINDHAM PKWY	302+97.6	35.7 RT	652.69	647.49*				647.49*				CB TA 4 DIA T24F&G	
659	WINDHAM PKWY	303+09.3	35.5 LT	652.73						648.00			CB TA 4 DIA T11V F&G	
660	WINDHAM PKWY	302+97.9	29.2 LT	652.81	EX 27"	647.90			EX 27"				MAN TA 5 DIA T1F CL	
661 *	WEBER RD	839+10.0	51.0 RT	652.47			647.06		647.26				CB TA 4 DIA T24F&G	
662 *	WEBER RD	837+85.4	57.0 RT	651.76	647.86						647.96		CB TA 4 DIA T24F&G	
662A	WEBER RD	837+85.4	6.0 RT	652.92			648.20						INLETS TA T8G	
663 *	WEBER RD	837+36.7	79.9 RT	651.42				646.06			646.26		CB TA 4 DIA T24F&G	
664 *	WEBER RD	837+49.0	69.4 RT	651.47				646.32					INLETS TA T24F&G	
700	I-55 EXPWY	3106+97.0	67.0 RT	651.00		647.19							MAN TA 4 DIA T1F CL	
701	I-55 EXPWY	3107+25.0	67.0 RT	651.10				647.08		647.08			MAN TA 4 DIA T1F CL	
702	I-55 EXPWY	3107+25.0	88.0 RT	N/A							647.00		PRC FLAR END SEC 12	
703	I-55 EXPWY	3107+93.0	65.0 LT	651.40		647.97							MAN TA 4 DIA T1F CL	
704	I-55 EXPWY	3108+58.0	69.0 LT	650.80						647.70	647.70		MAN TA 4 DIA T1F CL	
705	I-55 EXPWY	3108+58.0	117.0 LT	N/A				647.50					PRC FLAR END SEC 12	
750	I-55 RAMP B	6013+88.5	16.0 LT	660.12		656.94							INLETS TA T1F OL	
751	I-55 RAMP B	6015+00.0	18.4 LT	661.91		656.64		656.39		656.39			CB TA 4 DIA T1F OL	
752	I-55 RAMP B	6016+50.0	18.8 LT	664.16						658.11			INLETS TA T1F OL	
753	I-55 RAMP B	6015+00.0	42.3 RT	N/A							655.80		CONC ES 542001 15 1:4	
800 *	WEBER RD	867+00.0	46.0 LT	655.97	648.85				648.85				INLETS TB T1F OL	
801 *	WEBER RD	869+50.0	49.0 LT	655.58	649.59				649.59				INLETS TB T1F OL	
802 *	WEBER RD	873+00.0	52.0 LT	653.88	650.63				650.63				INLETS TB T1F OL	
803 *	WEBER RD	874+00.0	53.0 LT	653.41					650.93				INLETS TB T1F OL	

PIPE NUMBER	PIPE LENGTH (FOOT)	PIPE TYPE AND SIZE	PIPE SLOPE	TRENCH BACKFILL	CONTR LOWSTR MATL SPL	COMMENTS
				(CU YD)	(CU YD)	
606	21	STORM SEW CL A 1 12	0.50%	4	-	
607	19	SS RG CL A 1 24	1.88%	2	-	
608	87	STORM SEW CL A 1 24	0.60%	18	-	
650	35	STORM SEW CL A 2 12	1.00%	13	-	
651	10	STORM SEW CL A 2 12	1.00%	4	-	
653	5	STORM SEW CL A 2 24	1.00%	3	-	
654	5	STORM SEW CL A 1 24	1.00%	2	-	
656	59	STORM SEW CL A 2 12	1.69%	14	-	
659	10	STORM SEW CL A 2 12	1.00%	3	-	
661	12	STORM SEW CL A 2 12	0.50%		3	
662	120	STORM SEW CL A 2 12	0.50%	27	-	
662A	48	STORM SEW CL A 2 12	0.50%		10	
663	12	STORM SEW CL A 2 12	0.50%	4	-	
664	12	SS RG CL A 2 12	0.50%	4	-	
700	24	STORM SEW CL A 1 12	0.44%	-	-	
701	19	STORM SEW CL A 1 12	0.44%	-	-	
703	61	STORM SEW CL A 1 12	0.44%	-	-	
704	46	STORM SEW CL A 1 12	0.44%	-	-	
750	109	STORM SEW CL A 2 12	0.50%	21	-	
751	59	STORM SEW CL A 1 15	1.00%	9	-	
752	147	STORM SEW CL A 2 12	1.00%	48	-	
	40	STORM SEW CL A 1 42	6.50%	16	-	SEE NOTE 1
	40	STORM SEW CL A 1 36	1.75%	16	-	SEE NOTE 1
800	76	STORM SEW CL B 2 10	0.30%	64	-	
801	246	STORM SEW CL B 2 10	0.30%	217	-	
802	346	STORM SEW CL B 2 10	0.30%	127	-	
803	100	STORM SEW CL B 2 10	0.30%	20	-	

- * INDICATES PROPOSED STRUCTURE SHALL BE BACKFILLED WITH CLSM, SPECIAL.
- EXISTING PIPE TO BE CONNECTED TO PROPOSED DRAINAGE STRUCTURE. THE CONTRACTOR SHALL VERIFY EXISTING INVERT PRIOR TO STRUCTURE FABRICATION.
- ** SEE IDOT STANDARD DETAIL 542311 TRAVERSABLE PIPE GRATE OR DRAINAGE DETAILS FOR SCHEDULE AND DETAILS OF CONCRETE END SECTIONS OR HEADWALLS THAT REQUIRE TRAVERSABLE PIPE GRATES.

- NOTES
1. QUANTITY PROVIDED FOR POSSIBLE LIGHTING CONFLICT WITH EXISTING STORM SEWER. SEE "EXISTING DRAINAGE PLAN REMINGTON BLVD / WINDHAM PARKWAY".

FILE NAME : D:\60X10-shr-drain08-DrainageSchedule08.dgn

	USER NAME : dbarnes	DESIGNED REM	REVISED -	STATE OF ILLINOIS DEPARTMENT OF TRANSPORTATION	PROPOSED DRAINAGE SCHEDULES			F.A.I./P RTE.	SECTION	COUNTY	TOTAL SHEETS	SHEET NO.
	DRAWN DGB	REVISIONS	REVISED -					*	(99-1HB-1) R-1	WILL	1508	563
	PLOT SCALE : 1:100	CHECKED PJO	REVISED -					CONTRACT NO. 60X10				
	PLOT DATE : 9/21/2017	DATE 11/15/17	REVISED -					* FAI 55, FAP 856 ILLINOIS FED. AID PROJECT				
				SCALE: AS SHOWN			SHEET NO. 8 OF 9 SHEETS		STA. TO STA.			

PROPOSED DRAINAGE STRUCTURE SCHEDULE SUMMARY			
PAY ITEM	PAY ITEM ABBREVIATION FROM SCHEDULE	TOTAL QUANTITY	UNITS
PRECAST REINFORCED CONCRETE FLARED END SECTIONS 12"	PRC FLAR END SEC 12	2	EACH
PRECAST REINFORCED CONCRETE FLARED END SECTIONS 18"	PRC FLAR END SEC 18	4	EACH
PRECAST REINFORCED CONCRETE FLARED END SECTIONS 24"	PRC FLAR END SEC 24	1	EACH
TRAVERSABLE PIPE GRATE FOR CONCRETE END SECTION	TRVRS PIPE GRT CON ES	469	FOOT
CONCRETE END SECTION, STANDARD 542001, 36", 1:2	CONC ES 542001 36 1:2	4	EACH
CONCRETE END SECTION, STANDARD 542001, 15", 1:3	CONC ES 542011 15 1:3	4	EACH
CONCRETE END SECTION, STANDARD 542001, 18", 1:3	CONC ES 542001 18 1:3	1	EACH
CONCRETE END SECTION, STANDARD 542001, 24", 1:3	CONC ES 542001 24 1:3	1	EACH
CONCRETE END SECTION, STANDARD 542001, 30", 1:3	CONC ES 542001 30 1:3	1	EACH
CONCRETE END SECTION, STANDARD 542001, 36", 1:3	CONC ES 542001 36 1:3	2	EACH
CONCRETE END SECTION, STANDARD 542001, 15", 1:4	CONC ES 542011 15 1:4	7	EACH
CONCRETE END SECTION, STANDARD 542001, 24", 1:4	CONC ES 542001 24 1:4	4	EACH
CONCRETE END SECTION, STANDARD 542001, 30", 1:4	CONC ES 542001 30 1:4	1	EACH
CONCRETE END SECTION, STANDARD 542001, 24", 1:6	CONC ES 542001 24 1:6	2	EACH
CONCRETE END SECTION, STANDARD 542001, 30", 1:6	CONC ES 542001 30 1:6	2	EACH
CATCH BASINS, TYPE A, 4'-DIAMETER, TYPE 1 FRAME OPEN LID	CB TA 4 DIA T1F OL	1	EACH
CATCH BASINS, TYPE A, 4'-DIAMETER, TYPE 8 GRATE	CB TA 4 DIA T8G	19	EACH
CATCH BASINS, TYPE A, 4'-DIAMETER, TYPE 11V FRAME AND GRATE	CB TA 4 DIA T11V F&G	15	EACH
CATCH BASINS, TYPE A, 4'-DIAMETER, TYPE 24 FRAME AND GRATE	CB TA 4 DIA T24F&G	99	EACH
CATCH BASINS, TYPE A, 5'-DIAMETER, TYPE 11V FRAME AND GRATE	CB TA 5 DIA T11V F&G	1	EACH
CATCH BASINS, TYPE A, 5'-DIAMETER, TYPE 24 FRAME AND GRATE	CB TA 5 DIA T24F&G	6	EACH
CATCH BASINS, TYPE C, TYPE 8 GRATE	CB TC T8G	1	EACH
CATCH BASINS, TYPE C, TYPE 24 FRAME AND GRATE	CB TC T24F&G	5	EACH
MANHOLES, TYPE A, 4'-DIAMETER, TYPE 1 FRAME, CLOSED LID	MAN TA 4 DIA T1F CL	30	EACH
MANHOLES, TYPE A, 5'-DIAMETER, TYPE 1 FRAME, CLOSED LID	MAN TA 5 DIA T1F CL	22	EACH
MANHOLES, TYPE A, 6'-DIAMETER, TYPE 1 FRAME, CLOSED LID	MAN TA 6 DIA T1F CL	10	EACH
MANHOLES, TYPE A, 7'-DIAMETER, TYPE 1 FRAME, CLOSED LID	MAN TA 7 DIA T1F CL	9	EACH
MANHOLES, TYPE A, 8'-DIAMETER, TYPE 1 FRAME, CLOSED LID	MAN TA 8 DIA T1F CL	2	EACH
MANHOLES, TYPE A, 9'-DIAMETER, TYPE 1 FRAME, CLOSED LID	MAN TA 9 DIA T1F CL	6	EACH
INLETS, TYPE A, TYPE 1 FRAME , OPEN LID	INLETS TA T1F OL	3	EACH
INLETS, TYPE A, TYPE 8 GRATE	INLETS TA T8G	4	EACH
INLETS, TYPE A, TYPE 11V FRAME AND GRATE	INLETS TA T11V F&G	4	EACH
INLETS, TYPE A, TYPE 24 FRAME AND GRATE	INLETS TA T24F&G	76	EACH
INLETS, TYPE B, TYPE 1 FRAME OPEN LID	INLETS TB T1F OL	4	EACH
INLETS, TYPE B, TYPE 8 GRATE	INLETS TB T8G	1	EACH
INLETS, TYPE B, TYPE 24 FRAME AND GRATE	INLETS TB T24F&G	3	EACH
CONTROLLED LOW-STRENGTH MATERIAL, SPECIAL	CONTR LOWSTR MATL SPL	2550	CU YD
MH, TY A, 8'-DIA, WITH 2 TYPE 1 FR, CL LID, RESTRICTOR PLATE	MH TA 8D W/2 T1FCL RP	1	EACH
MH, TY A, 9'-DIA, WITH 2 TYPE 1 FR, CL LID, RESTRICTOR PLATE	MH TA 9D W/2 T1FCL RP	1	EACH

PROPOSED STORM SEWER SCHEDULE SUMMARY			
PAY ITEM	PAY ITEM ABBREVIATION FROM SCHEDULE	TOTAL QUANTITY	UNITS
TRENCH BACKFILL	TRENCH BACKFILL	4448	CU YD
PRECAST CONCRETE BOX CULVERTS 8' X 4'	PCBC 8X4	98	FOOT
PRECAST CONCRETE BOX CULVERTS 10' X 5'	PCBC 10X5	101	FOOT
STORM SEWERS JACKED IN PLACE, 36"	STORM SEWERS JKD 36	381	FOOT
PIPE CULVERTS, CLASS A, TYPE 1 18"	P CUL CL A 1 18	30	FOOT
PIPE CULVERTS, CLASS A, TYPE 1 24"	P CUL CL A 1 24	110	FOOT
PIPE CULVERTS, CLASS A, TYPE 1 30"	P CUL CL A 1 30	105	FOOT
PIPE CULVERTS, CLASS A, TYPE 4 36"	P CUL CL A 4 36	197	FOOT
PIPE CULVERTS, CLASS A, TYPE 1 EQUIVALENT ROUND-SIZE 24"	P CUL CL A 1 EQRS 24	80	FOOT
STORM SEWERS, CLASS A, TYPE 1 12"	STORM SEW CL A 1 12	1065	FOOT
STORM SEWERS, CLASS A, TYPE 1 15"	STORM SEW CL A 1 15	295	FOOT
STORM SEWERS, CLASS A, TYPE 1 18"	STORM SEW CL A 1 18	37	FOOT
STORM SEWERS, CLASS A, TYPE 1 24"	STORM SEW CL A 1 24	242	FOOT
STORM SEWERS, CLASS A, TYPE 1 36"	STORM SEW CL A 1 36	40	FOOT
STORM SEWERS, CLASS A, TYPE 1 42"	STORM SEW CL A 1 42	40	FOOT
STORM SEWERS, CLASS A, TYPE 2 12"	STORM SEW CL A 2 12	6861	FOOT
STORM SEWERS, CLASS A, TYPE 2 15"	STORM SEW CL A 2 15	2251	FOOT
STORM SEWERS, CLASS A, TYPE 2 18"	STORM SEW CL A 2 18	2142	FOOT
STORM SEWERS, CLASS A, TYPE 2 24"	STORM SEW CL A 2 24	1369	FOOT
STORM SEWERS, CLASS A, TYPE 2 30"	STORM SEW CL A 2 30	899	FOOT
STORM SEWERS, CLASS A, TYPE 2 42"	STORM SEW CL A 2 42	187	FOOT
STORM SEWERS, CLASS A, TYPE 2 48"	STORM SEW CL A 2 48	623	FOOT
STORM SEWERS, CLASS A, TYPE 2 54"	STORM SEW CL A 2 54	1011	FOOT
STORM SEWERS, CLASS A, TYPE 3 15"	STORM SEW CL A 3 15	10	FOOT
STORM SEWERS, CLASS A, TYPE 3 36"	STORM SEW CL A 3 36	7	FOOT
STORM SEWERS, CLASS A, TYPE 3 48"	STORM SEW CL A 3 48	14	FOOT
STORM SEWERS, RUBBER GASKET, CLASS A, TYPE 1 15"	SS RG CL A 1 15	35	FOOT
STORM SEWERS, RUBBER GASKET, CLASS A, TYPE 1 24"	SS RG CL A 1 24	19	FOOT
STORM SEWERS, RUBBER GASKET, CLASS A, TYPE 2 12"	SS RG CL A 2 12	322	FOOT
STORM SEWERS, RUBBER GASKET, CLASS A, TYPE 2 15"	SS RG CL A 2 15	79	FOOT
STORM SEWERS, RUBBER GASKET, CLASS A, TYPE 2 18"	SS RG CL A 2 18	26	FOOT
STORM SEWERS, RUBBER GASKET, CLASS A, TYPE 2 24"	SS RG CL A 2 24	237	FOOT
STORM SEWERS, RUBBER GASKET, CLASS A, TYPE 2 30"	SS RG CL A 2 30	196	FOOT
STORM SEWERS, RUBBER GASKET, CLASS A, TYPE 2 54"	SS RG CL A 2 54	116	FOOT
CONTROLLED LOW-STRENGTH MATERIAL	CONTR LOW-STRENG	280	CU YD
CONTROLLED LOW-STRENGTH MATERIAL, SPECIAL	CONTR LOWSTR MATL SPL	8356	CU YD
STORM SEWER (WATER MAIN REQUIREMENTS) 12 INCH	STORM SEW WM REQ 12	378	FOOT
STORM SEWER (WATER MAIN REQUIREMENTS) 15 INCH	STORM SEW WM REQ 15	61	FOOT

FILE NAME : D:\60X10-shr-drain09-DrainageSchedule09.dgn

KNIGHT
Engineers & Architects

USER NAME : dbarnes	DESIGNED REM	REVISED -
PLOT SCALE : 1:100	DRAWN DGB	REVISED -
PLOT DATE : 11/10/2017	CHECKED PJO	REVISED -
	DATE 11/15/17	REVISED -

STATE OF ILLINOIS
DEPARTMENT OF TRANSPORTATION

PROPOSED DRAINAGE SCHEDULES

SCALE: AS SHOWN SHEET NO. 9 OF 9 SHEETS STA. TO STA.

F.A.I./P RTE.	SECTION	COUNTY	TOTAL SHEETS	SHEET NO.
*	(99-1HB-1) R-1	WILL	1508	564
			CONTRACT NO. 60X10	
* FAI 55, FAP 856 ILLINOIS FED. AID PROJECT				

PLAN	SURVEYED	DATE
	PLOTTED	
	CHECKED	
	ALIGNED	
	FILED	
	NO.	
	NAME	

PROFILE	SURVEYED	DATE
	PLOTTED	
	CHECKED	
	GRADES	
	STRUCTURE	
	NOTATION	
	CHWD	
	NO.	
	NAME	

FILE NAME = D:\EX10-shr-ct-ar-03-pr-dr-ar-03-weber.dgn

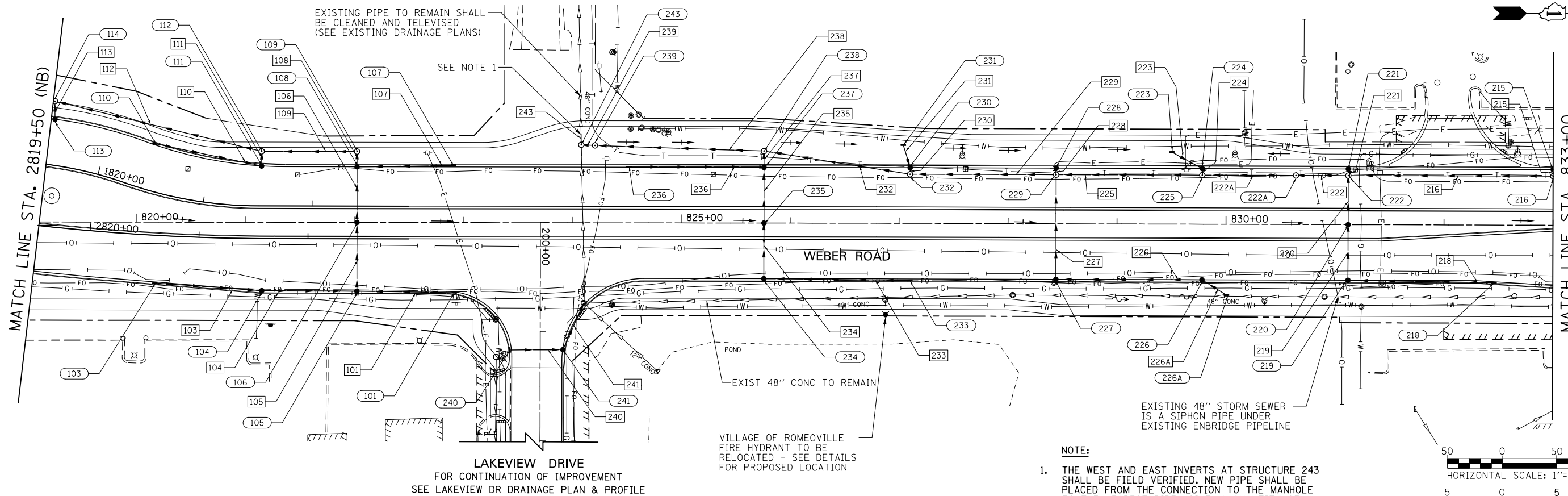

NOTE:
 1. THE WEST AND EAST INVERTS AT STRUCTURE 243 SHALL BE FIELD VERIFIED. NEW PIPE SHALL BE PLACED FROM THE CONNECTION TO THE MANHOLE TO THE NEAREST PIPE JOINT, A QUANTITY OF 14 FEET OF 48" STORM SEWER HAS BEEN PROVIDED.

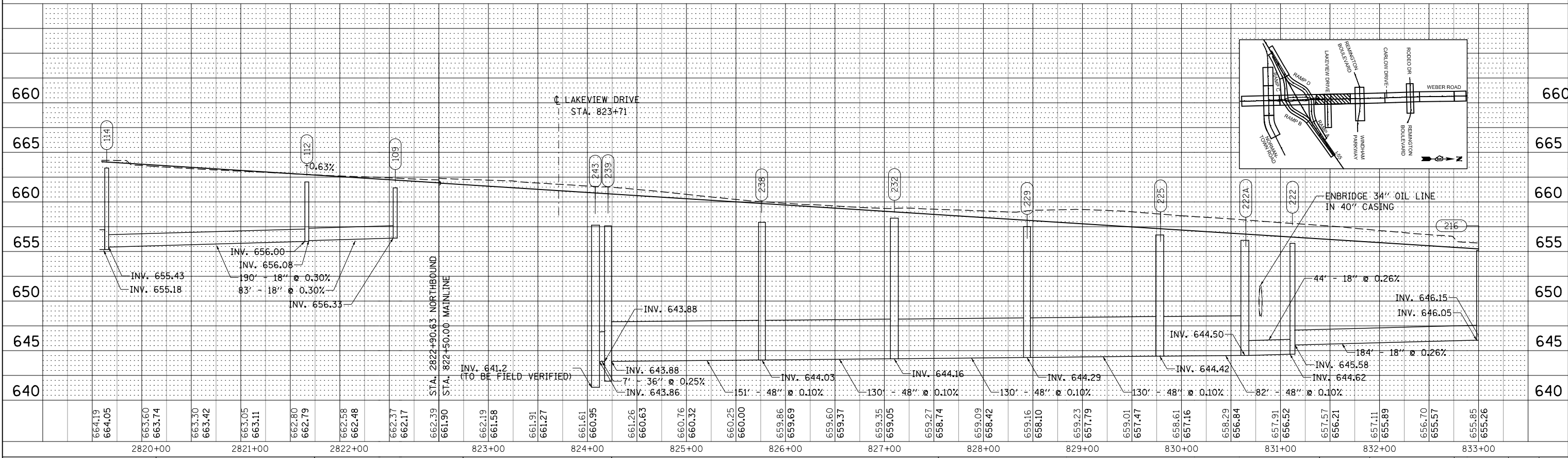
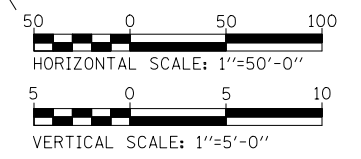

	USER NAME = mmaestra	DESIGNED - REM	REVISED -	STATE OF ILLINOIS DEPARTMENT OF TRANSPORTATION	PROPOSED DRAINAGE PLAN & PROFILE - WEBER ROAD	SCALE: 1" = 50' SHEET NO. 3 OF 22 SHEETS STA. 2819+50 TO STA. 833+00	F.A.I./P.R.T.E.	SECTION	COUNTY	TOTAL SHEETS	SHEET NO.
	PLOT SCALE = 1/99,9998	CHECKED - PJO	REVISED -				*	(99-1HB-1) R-1	WILL	1508	567
	PLOT DATE = 5/13/2017	DATE - 05/12/17	REVISED -				* FAI 55, FAP 856 ILLINOIS FED. AID PROJECT				

PLAN	SURVEYED	DATE
	PLOTTED	
	CHECKED	
	AT	
	BY	
	FILE NAME	

PROFILE	SURVEYED	DATE
	PLOTTED	
	CHECKED	
	BY	
	FILE NAME	

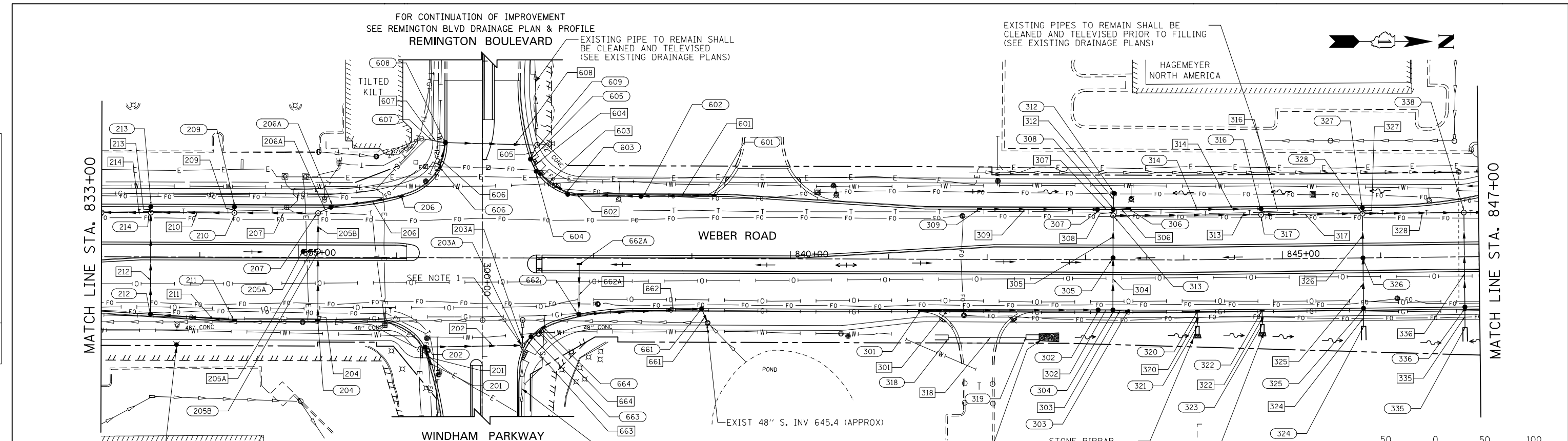

VILLAGE OF ROMEVILLE
FIRE HYDRANT TO BE
RELOCATED - SEE DETAILS
FOR PROPOSED LOCATION

NOTE:
1. THE WEST AND EAST INVERTS AT STRUCTURE 203A SHALL BE FIELD VERIFIED. NEW PIPE SHALL BE PLACED FROM THE CONNECTION TO THE MANHOLE TO THE NEAREST PIPE JOINT. A QUANTITY OF 7 FEET OF 42" STORM SEWER HAS BEEN PROVIDED.

EXISTING PIPE TO REMAIN SHALL BE CLEANED AND TELEVIEWED (SEE EXISTING DRAINAGE PLANS)

STONE RIPRAP (SEE SHEET DD-02)

STONE RIPRAP (SEE SHEET DD-02)

STONE RIPRAP (SEE SHEET DD-02)

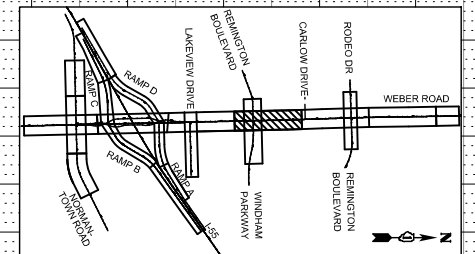
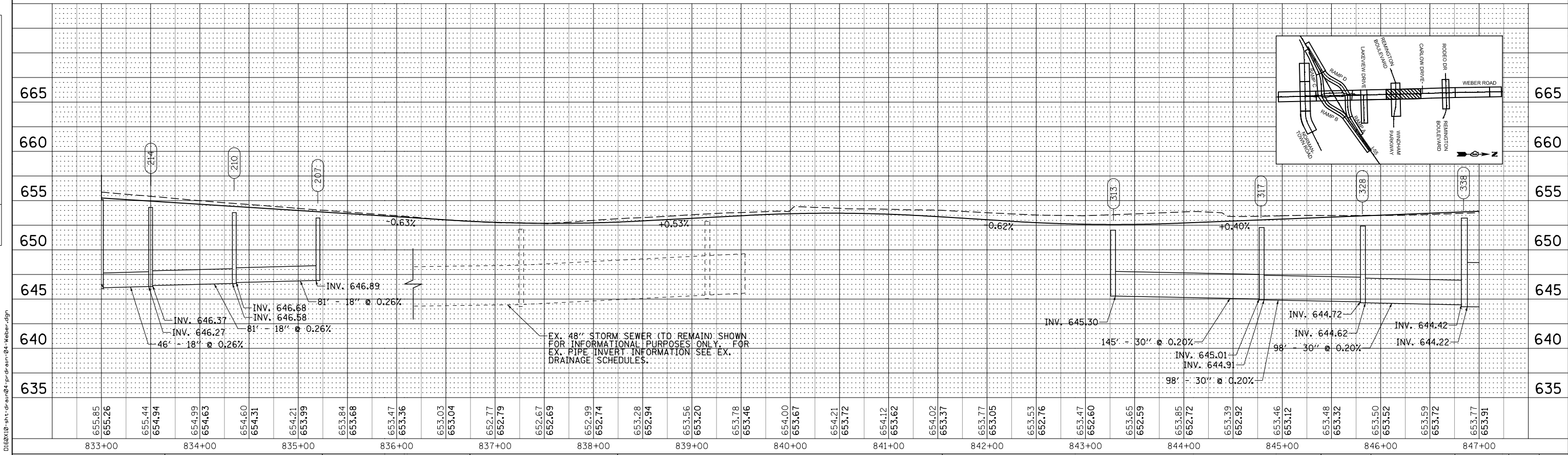
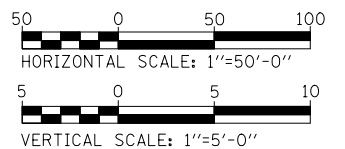

EX. 48" STORM SEWER (TO REMAIN SHOWN FOR INFORMATIONAL PURPOSES ONLY. FOR EX. PIPE INVERT INFORMATION SEE EX. DRAINAGE SCHEDULES.



USER NAME = mmaestra	DESIGNED - REM	REVISED -
PLOT SCALE = 1/99,998	DRAWN - DGB	REVISED -
PLOT DATE = 5/13/2017	CHECKED - PJO	REVISED -
	DATE = 05/12/17	REVISED -

STATE OF ILLINOIS
DEPARTMENT OF TRANSPORTATION

PROPOSED DRAINAGE PLAN & PROFILE - WEBER ROAD

SCALE: 1" = 50' SHEET NO. 4 OF 22 SHEETS STA. 833+00 TO STA. 847+00

F.A.I./P.R.T.E.	SECTION	COUNTY	TOTAL SHEETS	SHEET NO.
*	(99-1HB-1) R-1	WILL	1508	568
				CONTRACT NO. 60X10
* FAI 55, FAP 856 ILLINOIS FED. AID PROJECT				

PLAN	SURVEYED	DATE
	PLOTTED	
	CHECKED	
	ALIGNED	
	FILED	
NOTE BOOK NO.	FILE NAME	

PROFILE	SURVEYED	DATE
	PLOTTED	
	CHECKED	
	STRUCTURE	
NOTE BOOK NO.	NOTATION	

FILE NAME = D:\EX10-shr-ct-ar-08-pr-dr-ar-08-Weber.dgn

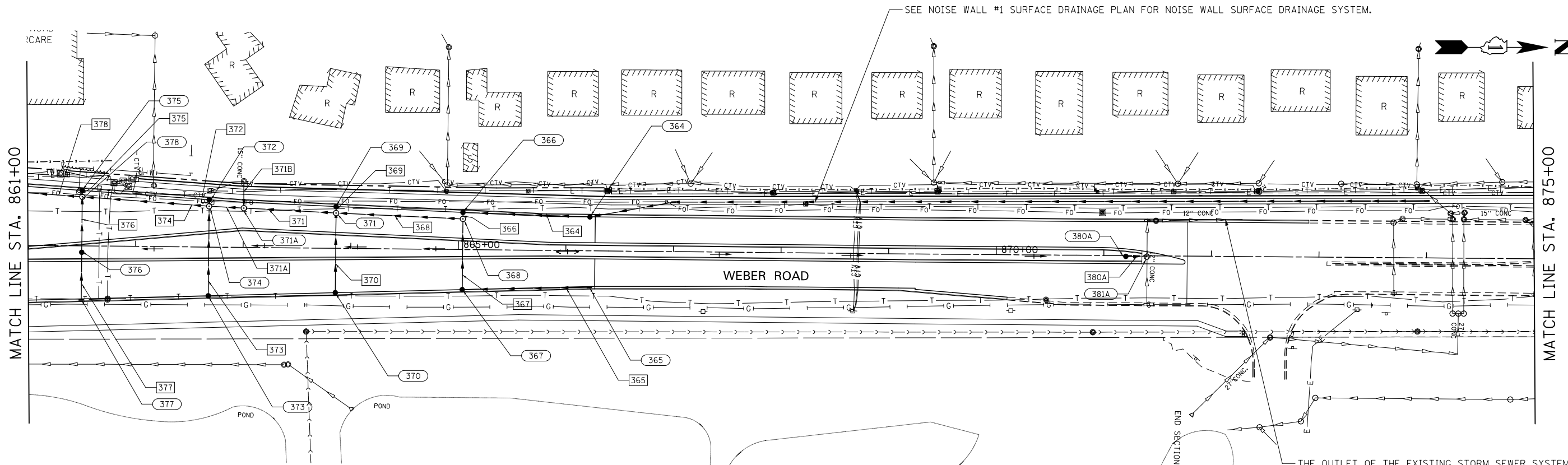

THE OUTLET OF THE EXISTING STORM SEWER SYSTEM SHALL BE FIELD VERIFIED PRIOR TO CONNECTING STRUCTURES 380A AND 381A TO THE EXISTING SYSTEM.

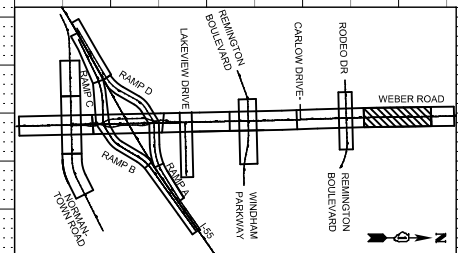
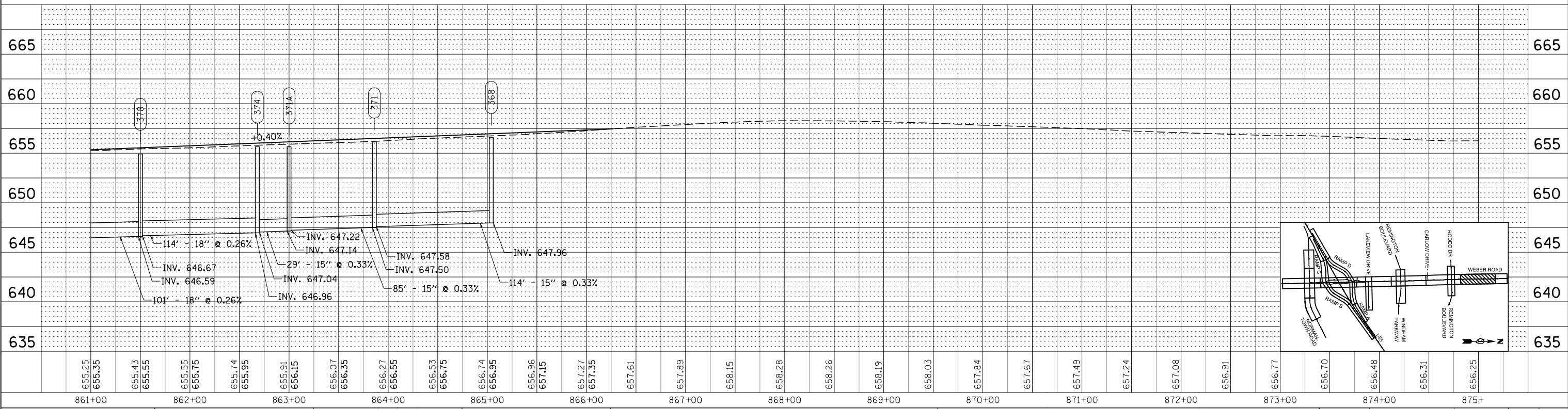
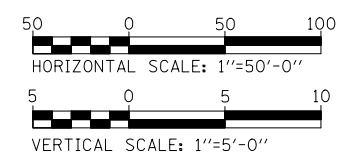

655.25	655.35	655.43	655.55	655.55	655.74	655.95	655.91	656.15	656.07	656.35	656.27	656.55	656.53	656.75	656.74	656.95	656.96	657.15	657.27	657.35	657.61	657.89	658.15	658.28	658.26	658.19	658.03	657.84	657.67	657.49	657.24	657.08	656.91	656.77	656.70	656.48	656.31	656.25
861+00	862+00	863+00	864+00	865+00	866+00	867+00	868+00	869+00	870+00	871+00	872+00	873+00	874+00	875+																								



USER NAME = mmaestra	DESIGNED - REM	REVISED -
PLOT SCALE = 1:99.9998	DRAWN - DGB	REVISED -
PLOT DATE = 8/24/2017	CHECKED - PJO	REVISED -
	DATE - 08/25/17	REVISED -

STATE OF ILLINOIS
DEPARTMENT OF TRANSPORTATION

PROPOSED DRAINAGE PLAN & PROFILE - WEBER ROAD
SCALE: 1" = 50' SHEET NO. 6 OF 22 SHEETS STA. 861+00 TO STA. 875+00

F.A.I./P.R.T.E.	SECTION	COUNTY	TOTAL SHEETS	SHEET NO.
*	(99-1HB-1) R-1	WILL	1508	570
CONTRACT NO. 60X10			* FAI 55, FAP 856 ILLINOIS FED. AID PROJECT	

PLAN	SURVEYED	BY	DATE
	PLOTTED		
	CHECKED		
	ALIGNED		
	FILE NAME		
	NO.		

PROFILE	SURVEYED	BY	DATE
	PLOTTED		
	CHECKED		
	STRUCTURE		
	NOT AT THIS CHKD		
	NO.		

FILE NAME = D:\EX10-shr-ct-ar-07-pr-dr-ar-07-weber.dgn

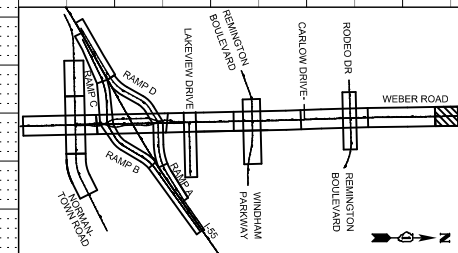
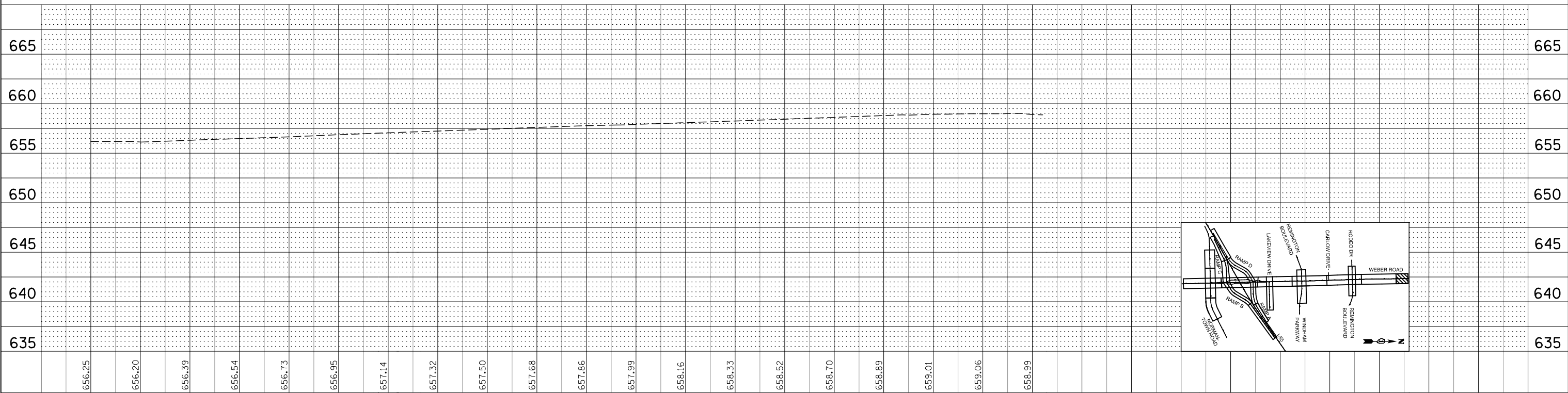
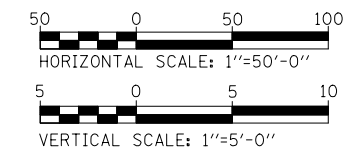
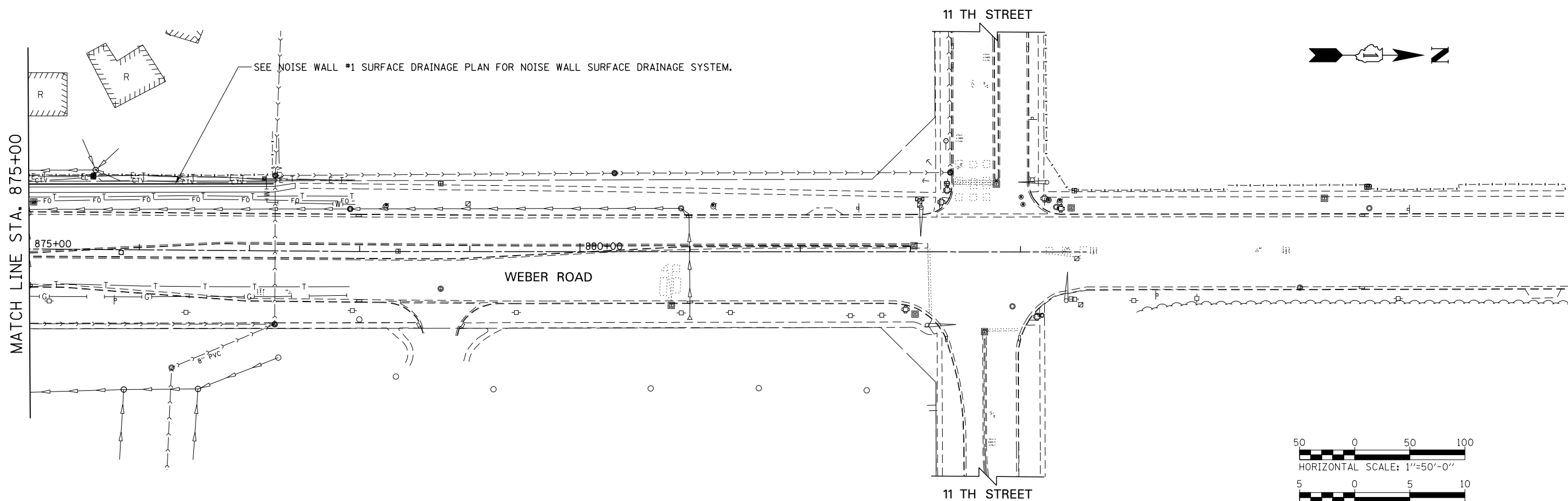

USER NAME = mmaestra	DESIGNED - REM	REVISED -
PLOT SCALE = 1:99.9998	DRAWN - DGB	REVISED -
PLOT DATE = 8/24/2017	CHECKED - PJO	REVISED -
	DATE - 08/25/17	REVISED -

STATE OF ILLINOIS
DEPARTMENT OF TRANSPORTATION

PROPOSED DRAINAGE PLAN & PROFILE - WEBER ROAD
SCALE: 1" = 50' SHEET NO. 7 OF 22 SHEETS STA. 875+00 TO STA. 877+41

F.A.I./P.R.T.E.	SECTION	COUNTY	TOTAL SHEETS	SHEET NO.
*	(99-1HB-1) R-1	WILL	1508	571
CONTRACT NO. 60X10				
* FAI 55, FAP 856 ILLINOIS FED. AID PROJECT				

- WETLAND NUMBER
- ISOLATED WETLAND
- WATERS OF THE U.S. (WOUS)
- PERMANENT IMPACT AREA

TOTAL WETLAND AREA SITE 8 : 0.90 ACRES
 PERMANENT IMPACT AREA: 0.26 ACRES
 (SEE RAMP C FOR ADDITIONAL IMPACTS TO SITE 8)

TOTAL WETLAND AREA LILY CACHE CREEK #2: 0.10 ACRES
 PERMANENT IMPACT AREA: 0.01 ACRES

PRECAST BOX CULVERT SCHEDULE (ASTM C 1577)						
STATION	TO STATION	SIZE (SPAN X HEIGHT)	SKEW	DESIGN FILL (FT)		PGE BACKFILL REQ
				MINIMUM	MAXIMUM	
91+95	91+83	10' X 5'	7°	3.4	3.7	YES
53.0' LT		47.0' RT		LENGTH: 95 FT		

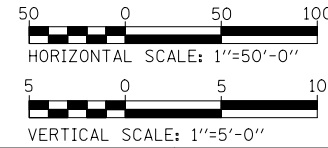
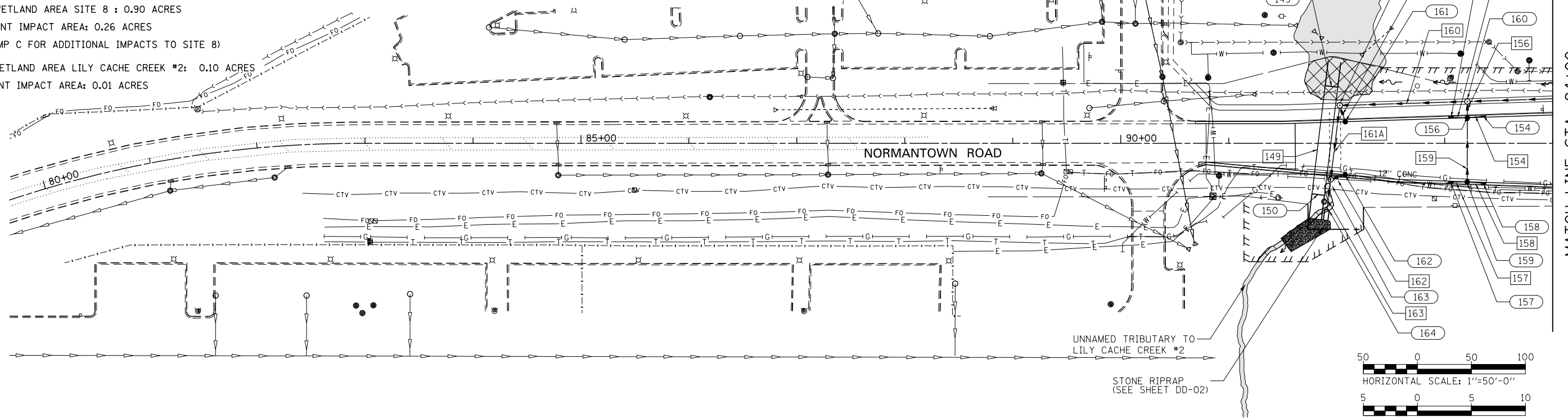

PLAN	SURVEYED	DATE
NOTE BOOK	PLOTTED	BY
NO.	CHECKED	
	ALIGNMENT	
	STRUCTURE	
	FILE NAME	

PROFILE	SURVEYED	DATE
NOTE BOOK	GRADES CHECKED	BY
NO.	STRUCTURE	
	NOT AT THIS CHORD	

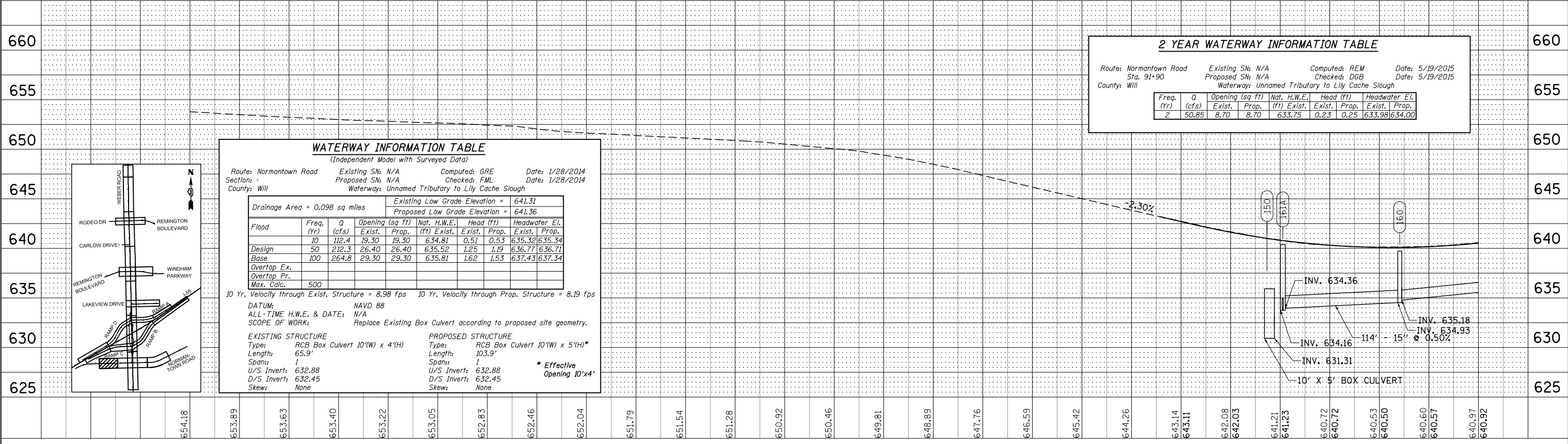

2 YEAR WATERWAY INFORMATION TABLE						
Route: Normantown Road		Existing SN: N/A		Computed: REM		Date: 5/19/2015
Sta. 91+90		Proposed SN: N/A		Checked: DGB		Date: 5/19/2015
County: Will		Waterway: Unnamed Tributary to Lily Cache Slough				
Freq. (Yr)	Q (cfs)	Opening (sq ft)	Nat. H.W.E. (ft)	Head (ft)	Headwater EL.	
2	50.85	8.70	8.70	633.75	0.23	0.25
					633.98	634.00

WATERWAY INFORMATION TABLE									
(Independent Model with Surveyed Data)									
Route: Normantown Road		Existing SN: N/A		Computed: GRE		Date: 1/28/2014			
Section: -		Proposed SN: N/A		Checked: FML		Date: 1/28/2014			
County: Will		Waterway: Unnamed Tributary to Lily Cache Slough							
Drainage Area = 0.098 sq miles				Existing Low Grade Elevation = 641.31			Proposed Low Grade Elevation = 641.36		
Flood	Freq. (Yr)	Q (cfs)	Opening (sq ft)	Nat. H.W.E. (ft)	Head (ft)	Headwater EL.			
10	10	112.4	19.30	19.30	634.81	0.51	0.53	635.32	635.34
Design	50	212.3	26.40	26.40	635.52	1.25	1.19	636.77	636.71
Base	100	264.8	29.30	29.30	635.81	1.62	1.53	637.43	637.34
Overtop Ex.									
Overtop Pr.									
Max. Calc.	500								
10 Yr. Velocity through Exist. Structure = 8.98 fps					10 Yr. Velocity through Prop. Structure = 8.19 fps				
DATUM: NAVD 88									
ALL-TIME H.W.E. & DATE: N/A									
SCOPE OF WORK: Replace Existing Box Culvert according to proposed site geometry.									
EXISTING STRUCTURE					PROPOSED STRUCTURE				
Type: RCB Box Culvert 10'(W) x 4'(H)					Type: RCB Box Culvert 10'(W) x 5'(H)*				
Length: 65.9'					Length: 103.9'				
Span: 1					Span: 1				
U/S Invert: 632.88					U/S Invert: 632.88				
D/S Invert: 632.45					D/S Invert: 632.45				
Skew: None					Skew: None				
					* Effective Opening 10'x4'				

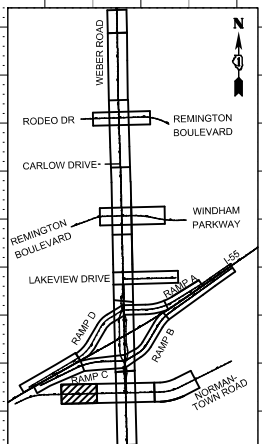

FILE NAME = D:\EX10-shr-ct-an-08-pr-dr-am-08-Normantown.dgn



USER NAME = mmaestra	DESIGNED - REM	REVISED -
PLOT SCALE = 1:99,998	DRAWN - DGB	REVISED -
PLOT DATE = 5/13/2017	CHECKED - PJO	REVISED -
	DATE = 05/12/17	REVISED -

STATE OF ILLINOIS
 DEPARTMENT OF TRANSPORTATION

PROPOSED DRAINAGE PLAN & PROFILE			
NORMANTOWN ROAD			
SCALE: 1" = 50'	SHEET NO. 8 OF 22 SHEETS	STA. 90+79 TO STA. 94+00	

F.A.I./P.RTE.	SECTION	COUNTY	TOTAL SHEETS	SHEET NO.
*	(99-1HB-1) R-1	WILL	1508	572
CONTRACT NO. 60X10				
* FAI 55, FAP 856 ILLINOIS FED. AID PROJECT				

PLAN	SURVEYED	BY	DATE
	PLOTTED		
	CHECKED		
	AT		
	FILE NAME		
	NO.		

PROFILE	SURVEYED	BY	DATE
	GRADES		
	CHECKED		
	STRUCTURE		
	NOT AT THIS CHKD		
	NO.		

FILE NAME = D:\EX10-shk-ctv-ar-09-pr-dr-ar-09-Normantown.dgn

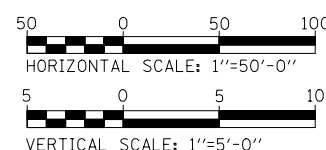
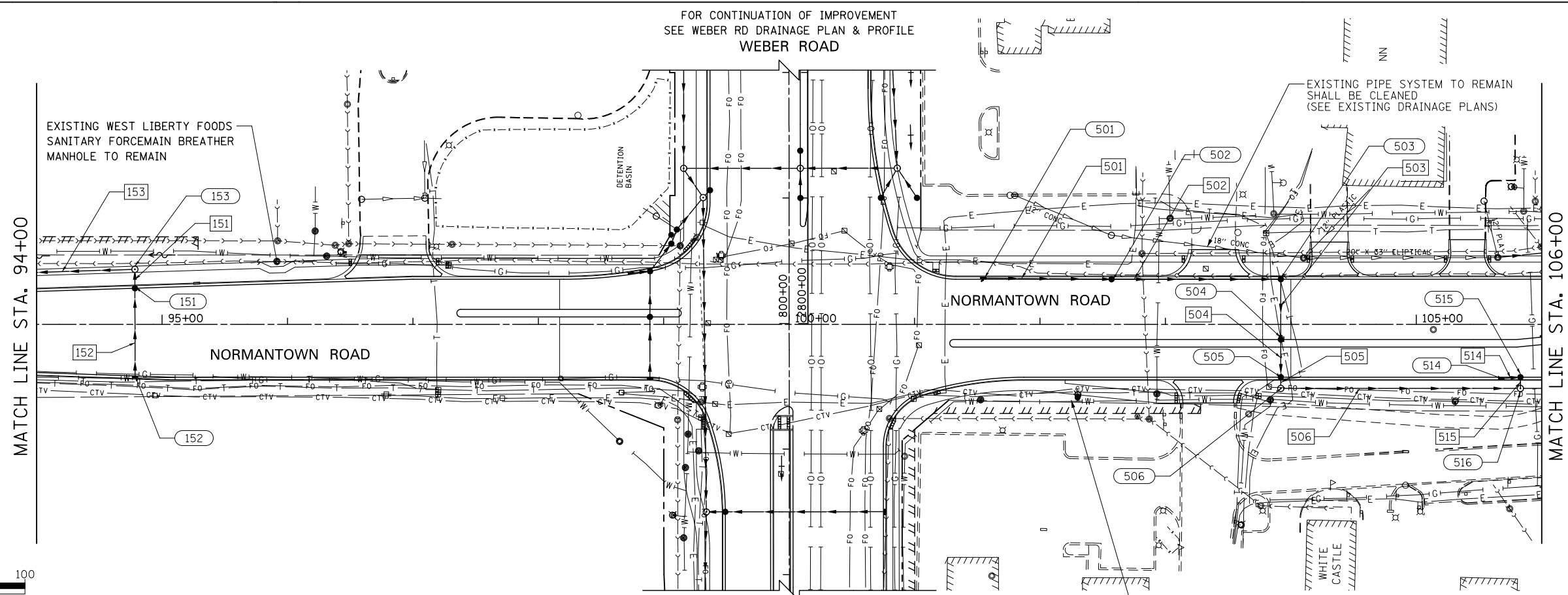

FOR CONTINUATION OF IMPROVEMENT
SEE WEBER RD DRAINAGE PLAN & PROFILE
WEBER ROAD

FOR CONTINUATION OF IMPROVEMENT
SEE WEBER RD DRAINAGE PLAN & PROFILE
WEBER ROAD

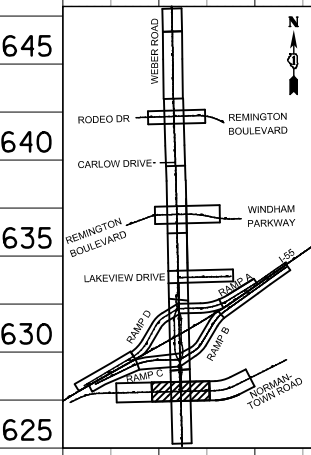
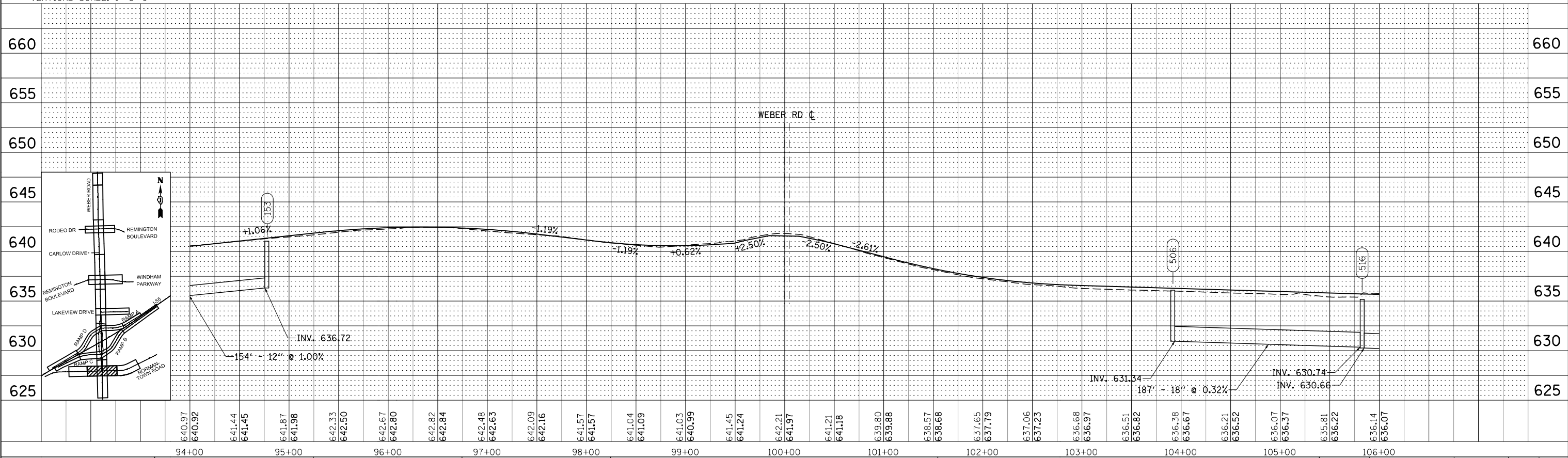

USER NAME = mmaestra	DESIGNED - REM	REVISED -
PLOT SCALE = 1/99,9998	DRAWN - DGB	REVISED -
PLOT DATE = 5/13/2017	CHECKED - PJO	REVISED -
	DATE - 05/12/17	REVISED -

STATE OF ILLINOIS
DEPARTMENT OF TRANSPORTATION

PROPOSED DRAINAGE PLAN & PROFILE
NORMANTOWN ROAD

SCALE: 1" = 50' SHEET NO. 9 OF 22 SHEETS STA. 94+00 TO STA. 106+00

F.A.I./P RTE.	SECTION	COUNTY	TOTAL SHEETS	SHEET NO.
*	(99-1HB-1) R-1	WILL	1508	573
CONTRACT NO. 60X10				
* FAI 55, FAP 856 ILLINOIS FED. AID PROJECT				

PLAN	SURVEYED	BY	DATE
	PLOTTED		
	CHECKED		
	ALIGNMENT		
	FILE NAME		
	NO.		

PROFILE	SURVEYED	BY	DATE
	PLOTTED		
	GRADES		
	CHECKED		
	STRUCTURE		
	NOT AT THIS CHKD		
	NO.		

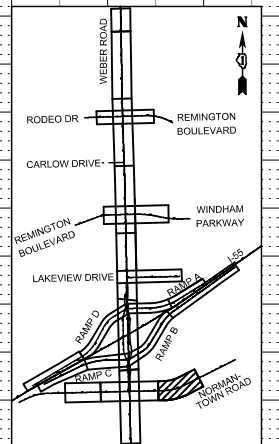
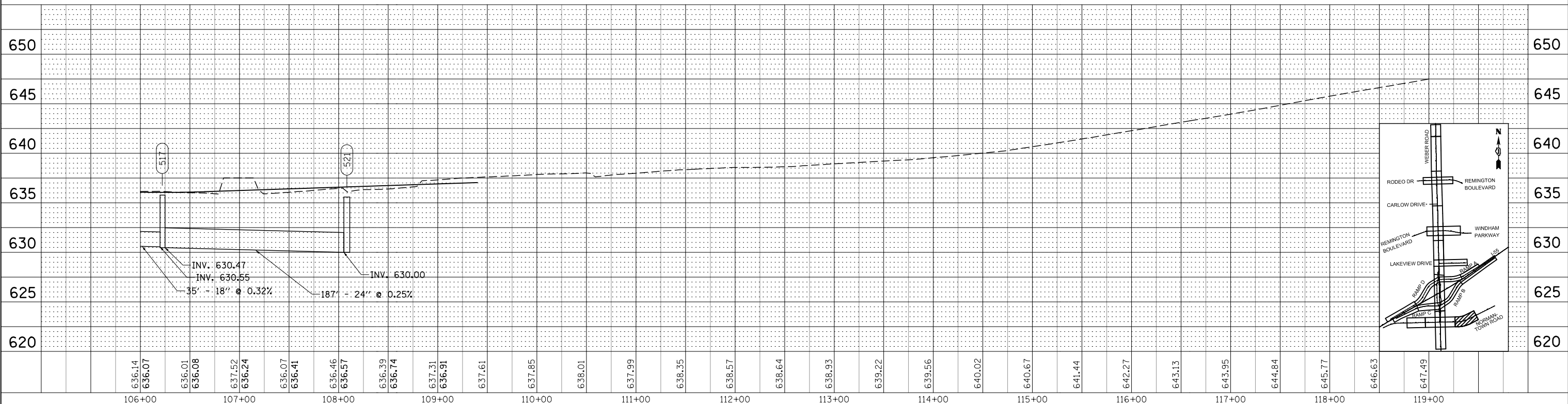
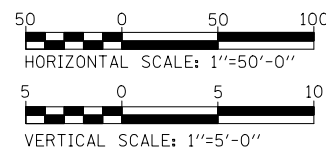
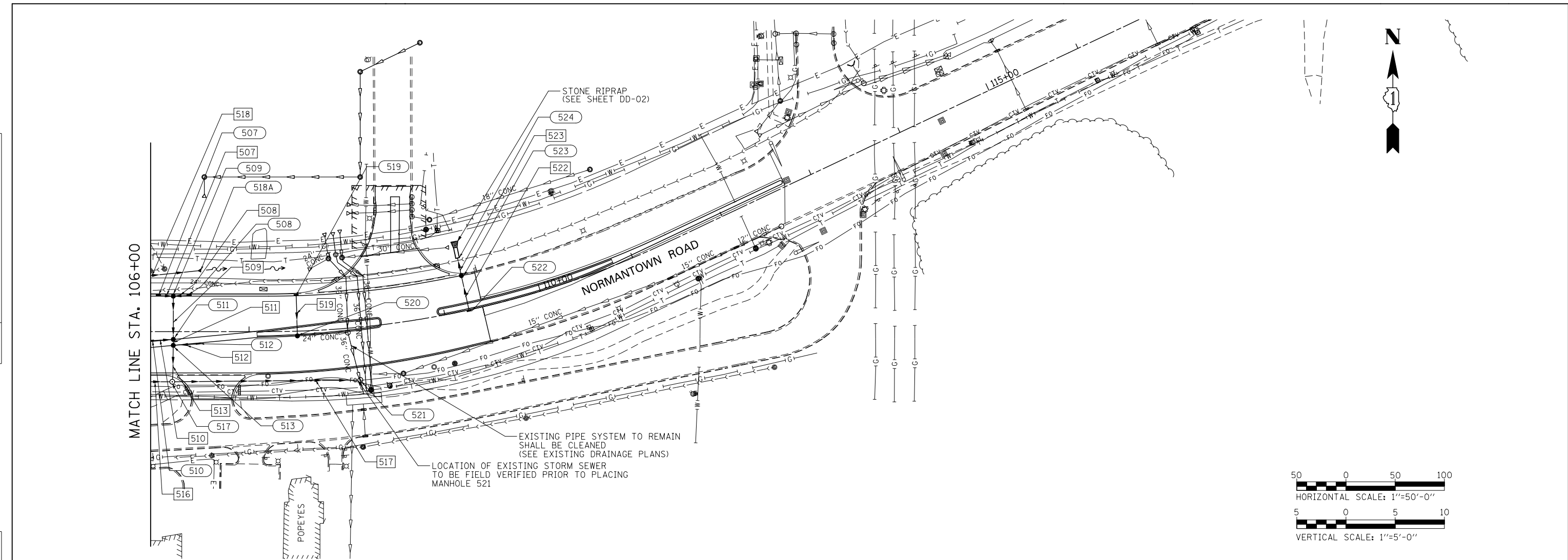

FILE NAME = D:\EX10-shr-10-normantown\10-normantown.dgn



USER NAME = mmaestra	DESIGNED - REM	REVISED -
PLOT SCALE = 1:99,998	DRAWN - DGB	REVISED -
PLOT DATE = 5/13/2017	CHECKED - PJO	REVISED -
	DATE = 05/12/17	REVISED -

STATE OF ILLINOIS
DEPARTMENT OF TRANSPORTATION

PROPOSED DRAINAGE PLAN & PROFILE
NORMANTOWN ROAD

SCALE: 1" = 50' SHEET NO. 10 OF 22 SHEETS STA. 106+00 TO STA. 112+79

F.A.I./P RTE.	SECTION	COUNTY	TOTAL SHEETS	SHEET NO.
*	(99-1HB-1) R-1	WILL	1508	574
				CONTRACT NO. 60X10
* FAI 55, FAP 856 ILLINOIS FED. AID PROJECT				

PLAN	SURVEYED	DATE
	PLOTTED	
	CHECKED	
	ALIGNED	
	FILE NAME	
	NO.	

PROFILE	SURVEYED	DATE
	PLOTTED	
	CHECKED	
	NOT AT THIS CHKD	
	NO.	

FOR CONTINUATION OF IMPROVEMENT
SEE WEBER RD DRAINAGE PLAN & PROFILE
WEBER ROAD

EXISTING PIPE TO REMAIN
SHALL BE CLEANED AND TELEVIEWED
(SEE EXISTING DRAINAGE PLANS)

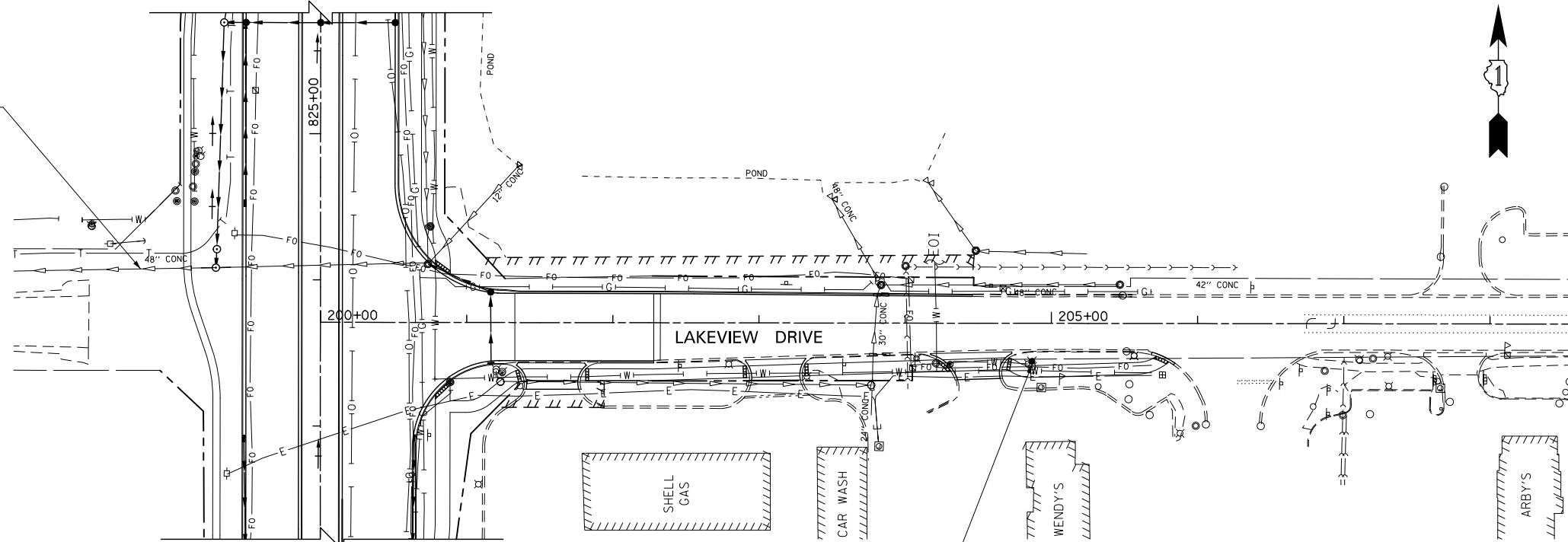

WEBER ROAD
FOR CONTINUATION OF IMPROVEMENT
SEE WEBER RD DRAINAGE PLAN & PROFILE

VILLAGE OF ROMEOVILLE
FIRE HYDRANT TO BE
MOVED - SEE DETAILS
FOR PROPOSED LOCATION

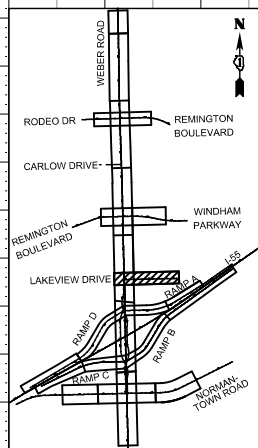
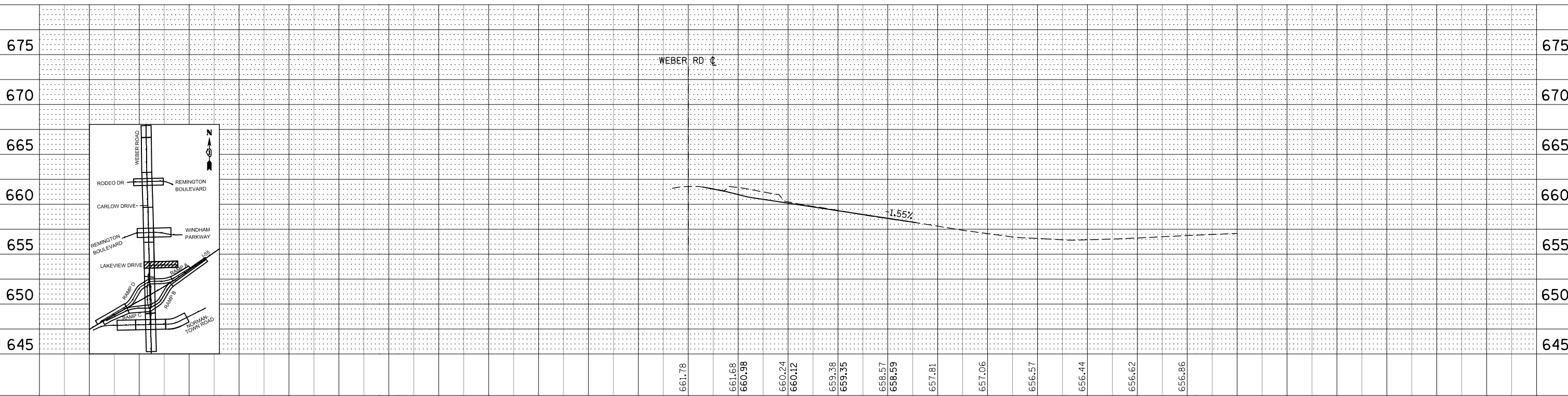
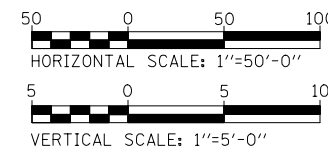

FILE NAME = D:\EX10-shr-draw\11-pro\11-Lakeview.dgn

KNIGHT
Engineers & Architects

USER NAME = mmaestra	DESIGNED - REM	REVISED -
PLOT SCALE = 1:99,9998	DRAWN - DGB	REVISED -
PLOT DATE = 5/13/2017	CHECKED - PJO	REVISED -
	DATE - 05/12/17	REVISED -

STATE OF ILLINOIS
DEPARTMENT OF TRANSPORTATION

PROPOSED DRAINAGE PLAN & PROFILE
LAKEVIEW DRIVE

SCALE: 1" = 50' SHEET NO. 11 OF 22 SHEETS STA. 200+00 TO STA. 205+42

F.A.I./P RTE.	SECTION	COUNTY	TOTAL SHEETS	SHEET NO.
*	(99-1HB-1) R-1	WILL	1508	575
				CONTRACT NO. 60X10
* FAI 55, FAP 856 ILLINOIS FED. AID PROJECT				

PLAN	SURVEYED	DATE
	PLOTTED	
	CHECKED	
	ALIGNED	
	FILED	
	NO.	

PROFILE	SURVEYED	DATE
	PLOTTED	
	CHECKED	
	GRADES	
	STRUCTURE	
	NOTATIONS	
	CHKD	
	NO.	

FILE NAME = D:\EX10-1\ht-1\plan13-per\plan13-RodeoRemington.dgn

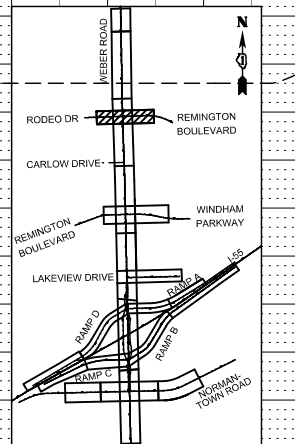
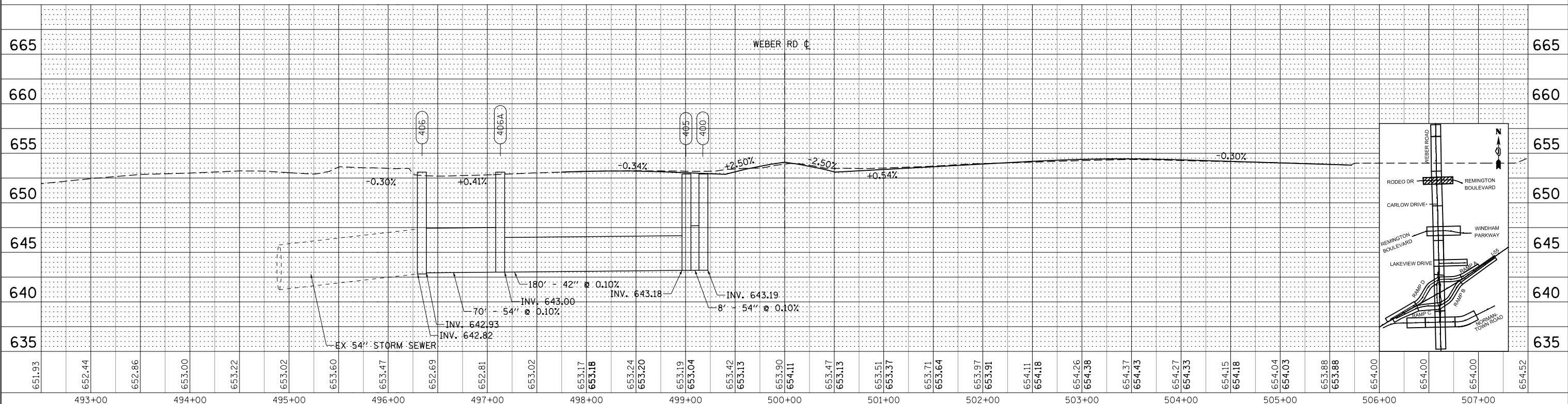
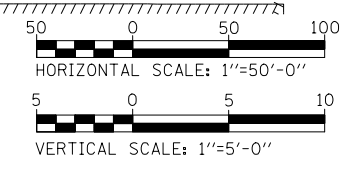
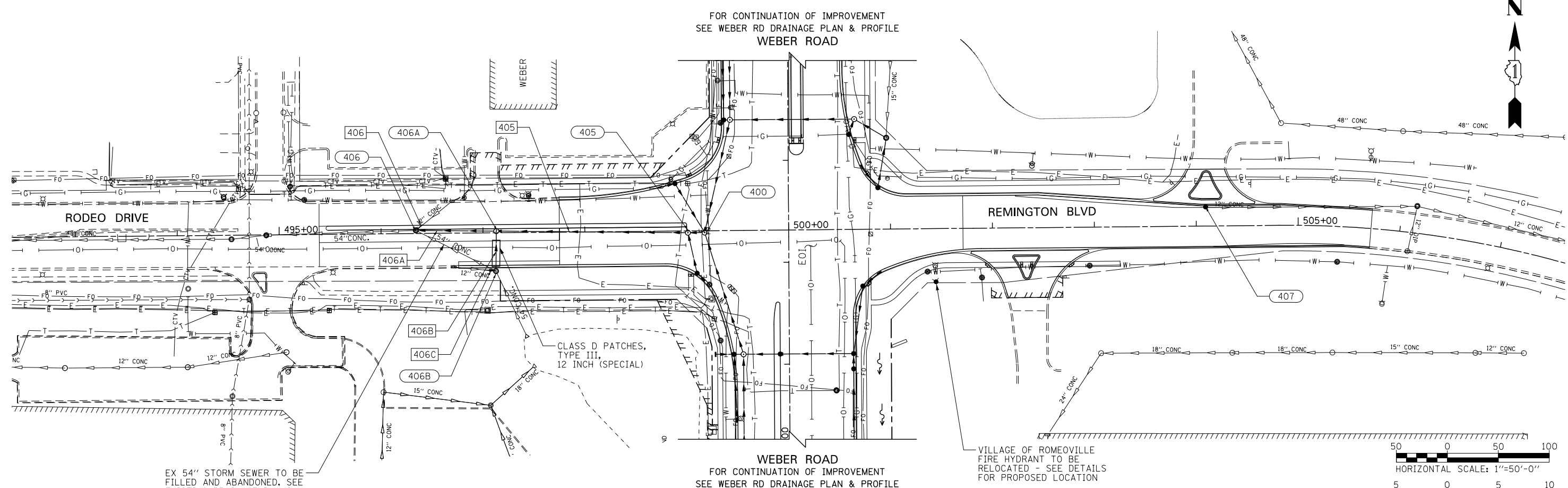

USER NAME = dbarnes	DESIGNED - REM	REVISED -
PLOT SCALE = 1:99,998	DRAWN - DGB	REVISED -
PLOT DATE = 6/14/2017	CHECKED - PJO	REVISED -
	DATE 06/16/17	REVISED -

STATE OF ILLINOIS
DEPARTMENT OF TRANSPORTATION

PROPOSED DRAINAGE PLAN & PROFILE			
RODEO DRIVE / REMINGTON BOULEVARD			
SCALE: 1" = 50'	SHEET NO. 13 OF 22 SHEETS	STA. 495+39 TO STA. 505+72	

F.A.I./P.R.T.E.	SECTION	COUNTY	TOTAL SHEETS	SHEET NO.
*	(99-1HB-1) R-1	WILL	1508	577
				CONTRACT NO. 60X10
* FAI 55, FAP 856 ILLINOIS FED. AID PROJECT				

SEE RAMP B
DRAINAGE PLAN/PROFILE SHEETS

SEE RAMP B
DRAINAGE PLAN/PROFILE SHEETS

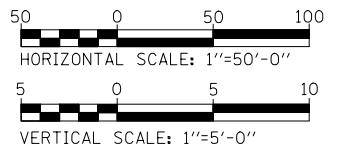
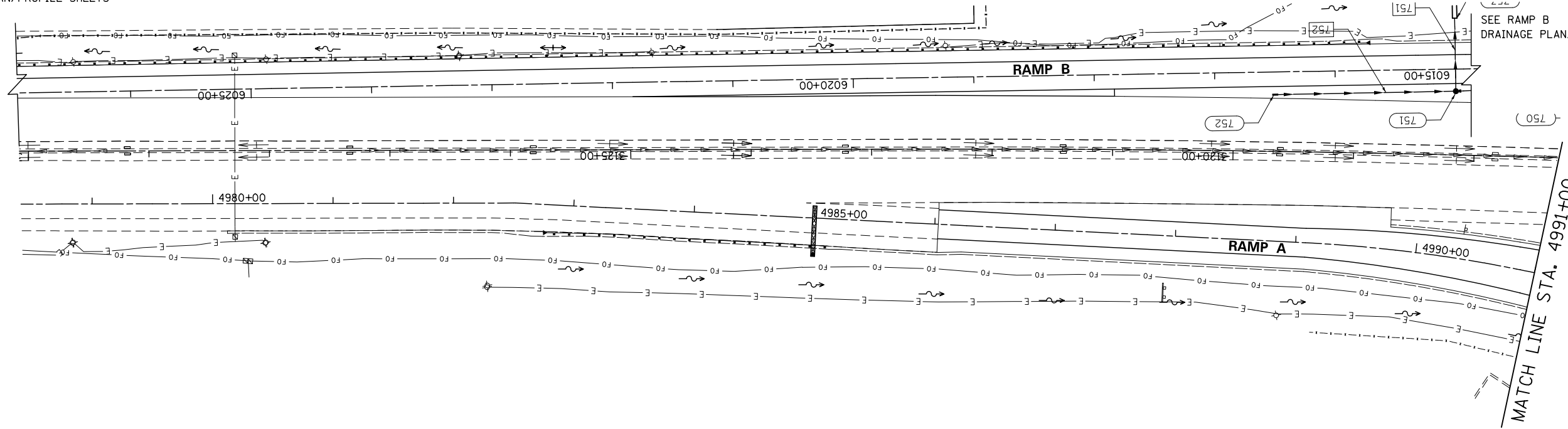

PLAN	SURVEYED	DATE
NOTE BOOK NO.	GRADES CHECKED	
	STRUCTURE NOTATIONS CHECKED	

PROFILE	SURVEYED	DATE
NOTE BOOK NO.	GRADES CHECKED	
	STRUCTURE NOTATIONS CHECKED	

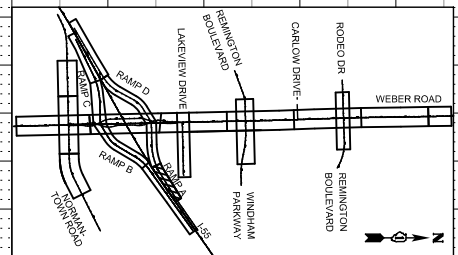
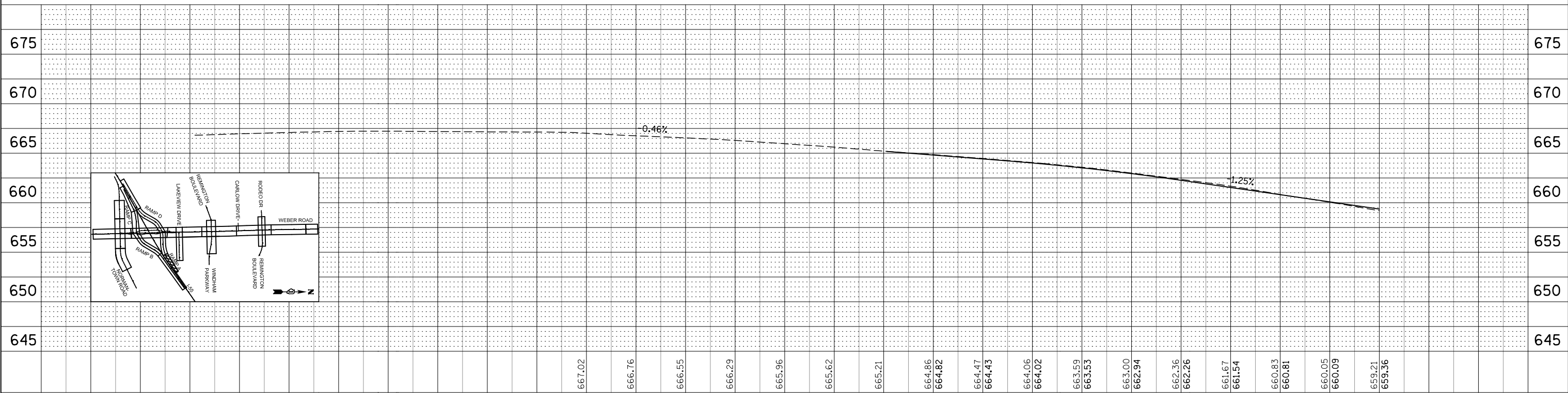

FILE NAME = D:\EX10-shr-d\proj\14-155 RampA.dgn



USER NAME = mmaestra	DESIGNED - REM	REVISED -
PLOT SCALE = 1:99,998	DRAWN - DGB	REVISED -
PLOT DATE = 5/13/2017	CHECKED - PJO	REVISED -
	DATE - 05/12/17	REVISED -

STATE OF ILLINOIS
DEPARTMENT OF TRANSPORTATION

PROPOSED DRAINAGE PLAN & PROFILE - RAMP A

SCALE: 1" = 50' SHEET NO. 14 OF 22 SHEETS STA. 4982+75 TO STA. 4991+00

F.A.I/P RTE.	SECTION	COUNTY	TOTAL SHEETS	SHEET NO.
*	(99-1HB-1) R-1	WILL	1508	578
CONTRACT NO. 60X10				
* FAI 55, FAP 856 ILLINOIS FED. AID PROJECT				

PLAN	SURVEYED	BY	DATE
	PLOTTED		
	CHECKED		
	ALIGNED		
	FILE NAME		
	NO.		

PROFILE	SURVEYED	BY	DATE
	PLOTTED		
	CHECKED		
	STRUCTURE		
	NOT AT THIS CHKD		
	NO.		

FILE NAME = D:\60X10-shr-td-ans15-per-dm-ans15-155 RampA.dwg

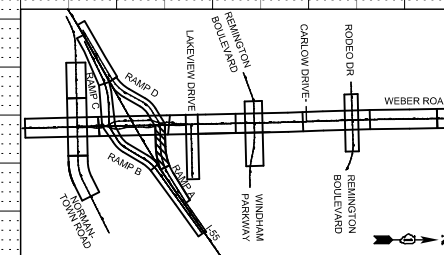
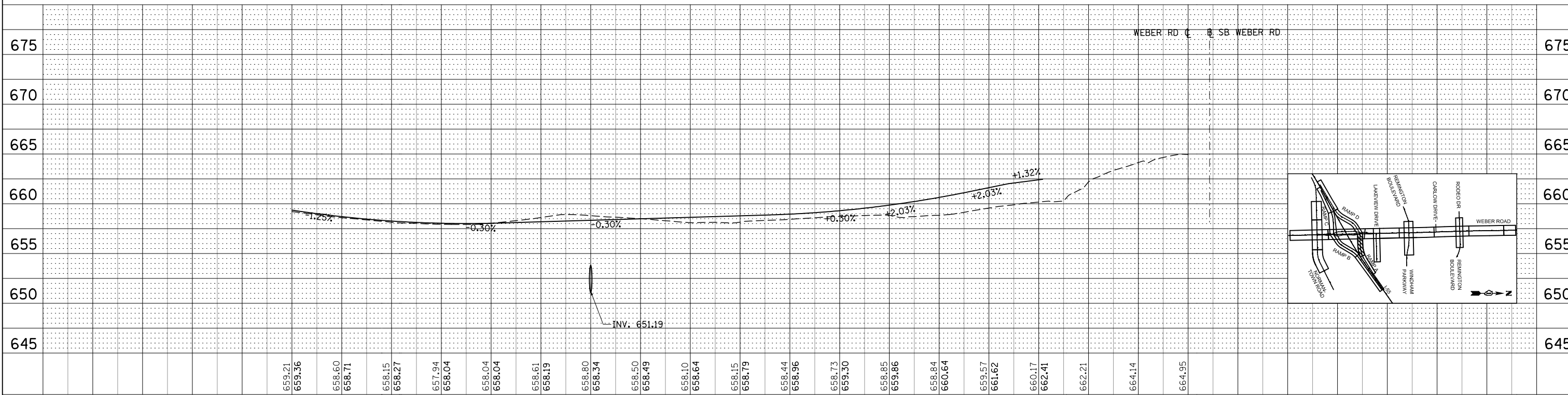
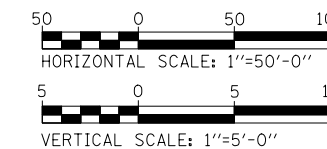
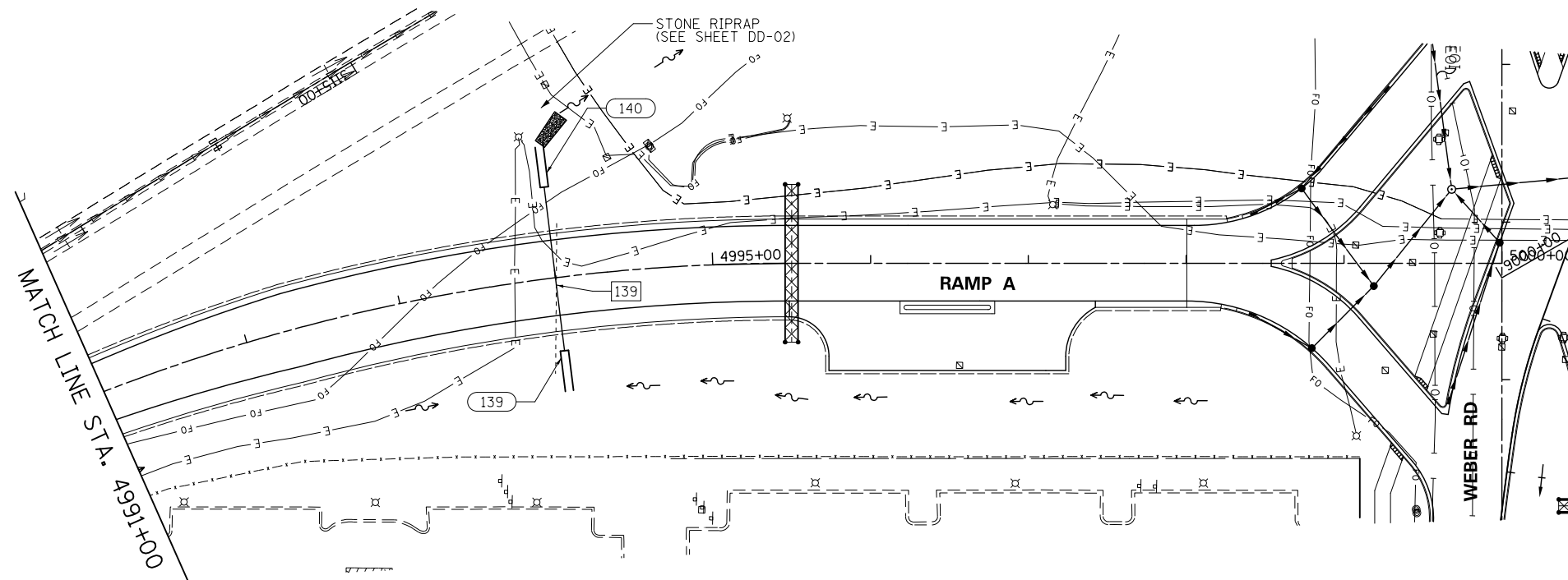

659.21 659.36	658.60 658.71	658.15 658.27	657.94 658.04	658.04 658.04	658.61 658.19	658.80 658.34	658.50 658.49	658.10 658.64	658.15 658.79	658.44 658.96	658.73 659.30	658.85 659.86	658.84 660.64	659.57 661.62	660.17 662.41	662.21	664.14	664.95
4991+00		4992+00		4993+00		4994+00		4995+00		4996+00		4997+00		4998+00		4999+00		5000+00

KNIGHT
Engineers & Architects

USER NAME = mmaestra	DESIGNED - REM	REVISED -
	DRAWN - DGB	REVISED -
PLOT SCALE = 1:99,998	CHECKED - PJO	REVISED -
PLOT DATE = 5/13/2017	DATE - 05/12/17	REVISED -

STATE OF ILLINOIS
DEPARTMENT OF TRANSPORTATION

PROPOSED DRAINAGE PLAN & PROFILE - RAMP A

SCALE: 1" = 50' SHEET NO. 15 OF 22 SHEETS STA. 4991+00 TO STA. 5000+00

F.A.I./P RTE.	SECTION	COUNTY	TOTAL SHEETS	SHEET NO.
*	(99-1HB-1) R-1	WILL	1508	579
CONTRACT NO. 60X10				
* FAI 55, FAP 856 ILLINOIS FED. AID PROJECT				

PLAN	SURVEYED	BY	DATE
	PLOTTED		
	CHECKED		
	FILE NAME		
	NO.		

PROFILE	SURVEYED	BY	DATE
	PLOTTED		
	CHECKED		
	FILE NAME		
	NO.		

FILE NAME = D:\EX10-shr-ct-ans17-pro-ans17-155 RampB.dgn

SEE RAMP A
DRAINAGE PLAN/PROFILE SHEETS

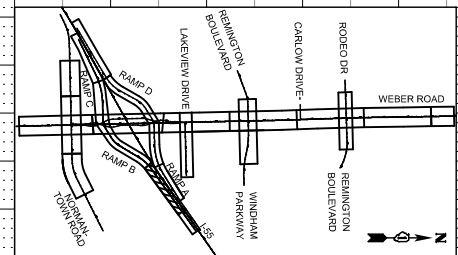
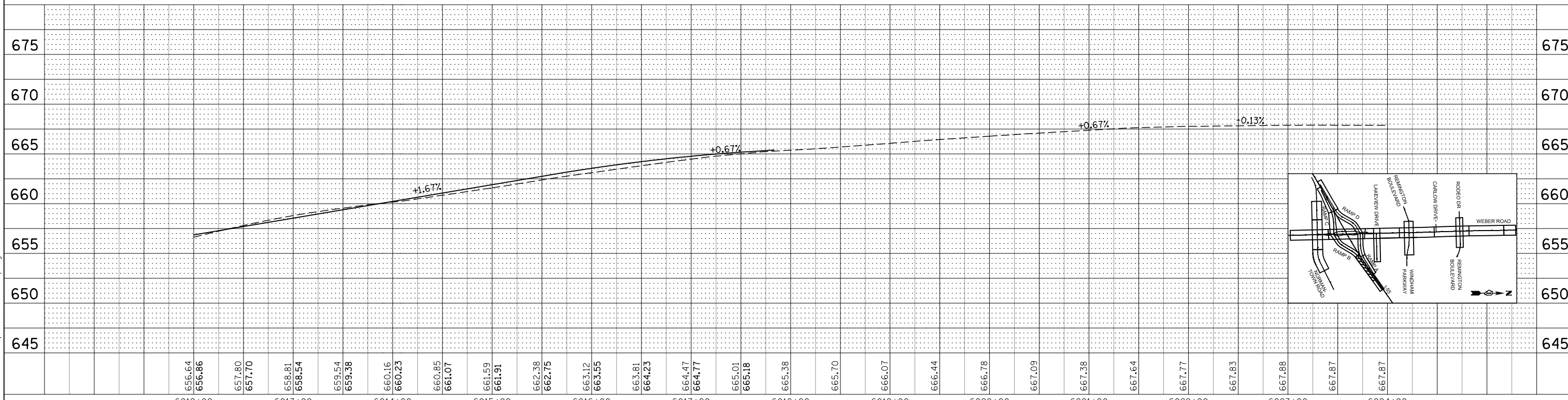
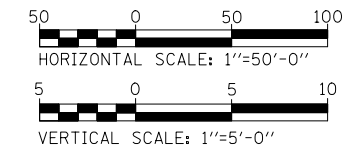
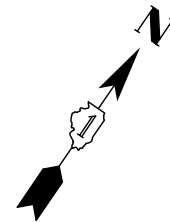
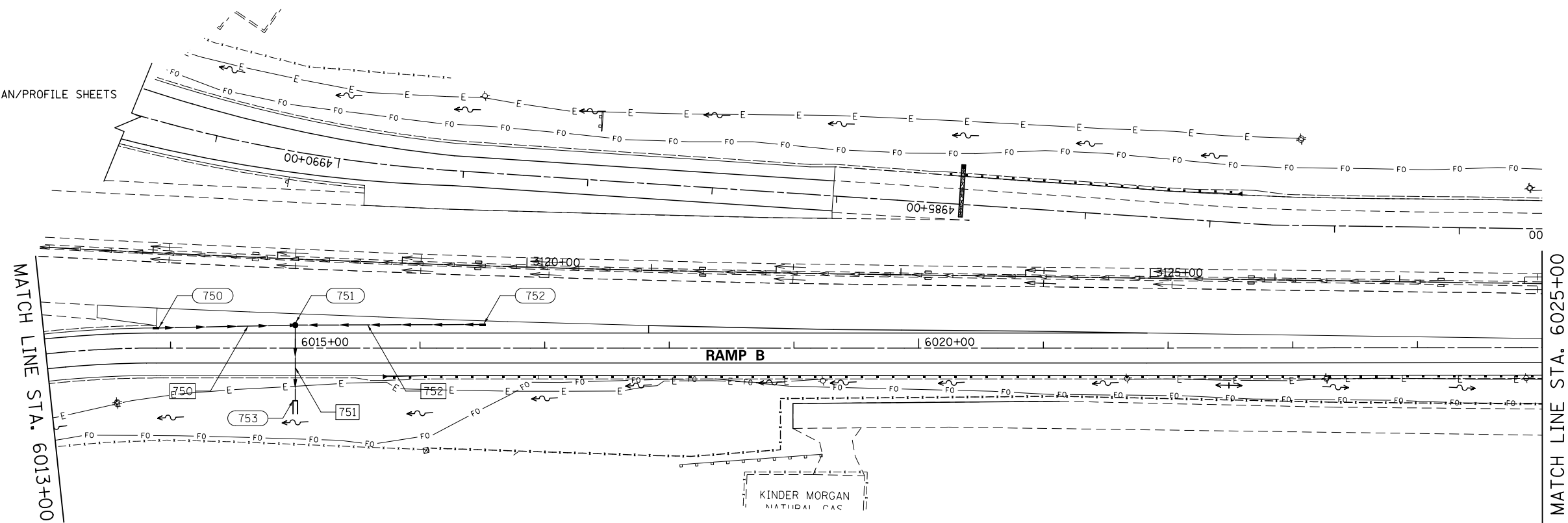

656.64	656.86	657.80	657.70	658.81	658.54	659.54	659.38	660.16	660.23	660.85	661.07	661.59	661.91	662.38	662.75	663.12	663.55	663.81	664.23	664.47	664.77	665.01	665.18	665.38	665.70	666.07	666.44	666.78	667.09	667.38	667.64	667.77	667.83	667.88	667.87	667.87
6012+00		6013+00		6014+00		6015+00		6016+00		6017+00		6018+00		6019+00		6020+00		6021+00		6022+00		6023+00		6024+00												



USER NAME = mmaestra	DESIGNED - REM	REVISED -
	DRAWN - DGB	REVISED -
PLOT SCALE = 1:99,9998	CHECKED - PJO	REVISED -
PLOT DATE = 5/13/2017	DATE - 05/12/17	REVISED -

STATE OF ILLINOIS
DEPARTMENT OF TRANSPORTATION

PROPOSED DRAINAGE PLAN & PROFILE - RAMP B

SCALE: 1" = 50' SHEET NO. 17 OF 22 SHEETS STA. 6012+00 TO STA. 6025+00

F.A.I./P RTE.	SECTION	COUNTY	TOTAL SHEETS	SHEET NO.
*	(99-1HB-1) R-1	WILL	1508	581
CONTRACT NO. 60X10				

* FAI 55, FAP 856 ILLINOIS FED. AID PROJECT

PLAN	SURVEYED	BY	DATE
	PLOTTED		
	CHECKED		
	ALIGNED		
	FILE NAME		
	NO.		

PROFILE	SURVEYED	BY	DATE
	PLOTTED		
	CHECKED		
	STRUCTURE		
	NOTATION		
	CHKD		
	NO.		

FILE NAME = D:\60X10-shr-ct-ans18-per-ans18-155 RampB.dgn

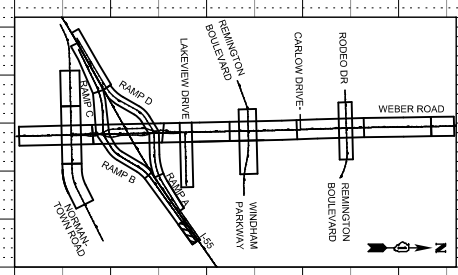
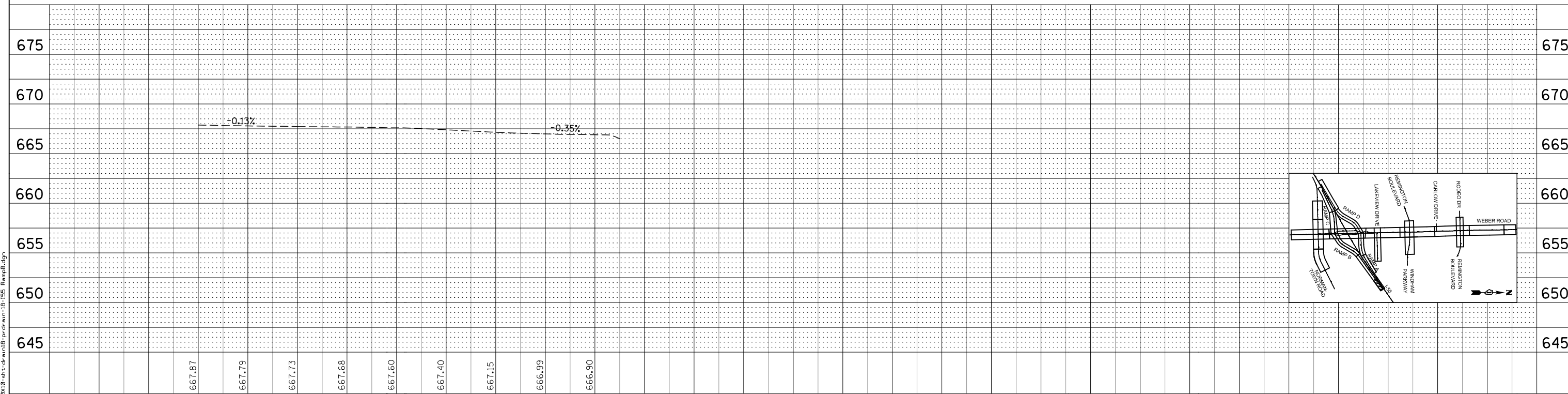
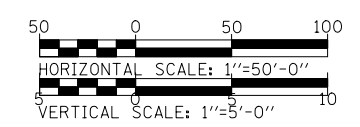
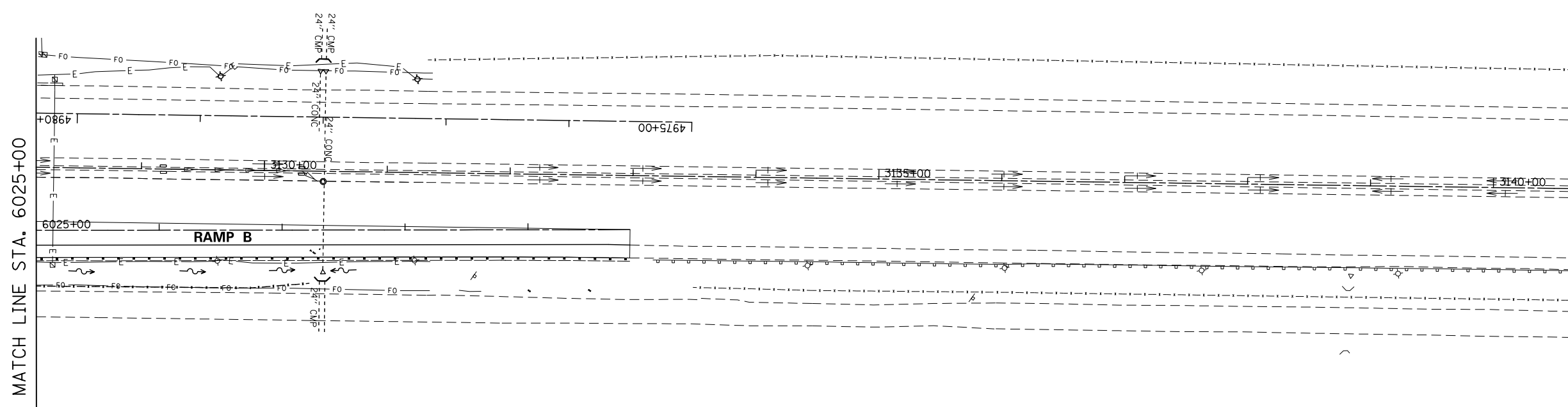

USER NAME = mmaestra	DESIGNED - REM	REVISED -
PLOT SCALE = 1/99,9998	DRAWN - DGB	REVISED -
PLOT DATE = 5/13/2017	CHECKED - PJO	REVISED -
	DATE = 05/12/17	REVISED -

STATE OF ILLINOIS
DEPARTMENT OF TRANSPORTATION

PROPOSED DRAINAGE PLAN & PROFILE - RAMP B
SCALE: 1" = 50' SHEET NO. 18 OF 22 SHEETS STA. 6025+00 TO STA. 6029+83

F.A.I./P RTE.	SECTION	COUNTY	TOTAL SHEETS	SHEET NO.
*	(99-1HB-1) R-1	WILL	1508	582
CONTRACT NO. 60X10				
* FAI 55, FAP 856 ILLINOIS FED. AID PROJECT				

PLAN	SURVEYED	BY	DATE
	PLOTTED		
	CHECKED		
	ALIGNED		
	FILE NAME		
	NO.		

PROFILE	SURVEYED	BY	DATE
	PLOTTED		
	CHECKED		
	STRUCTURE		
	NOT AT THIS CHFD		
	NO.		

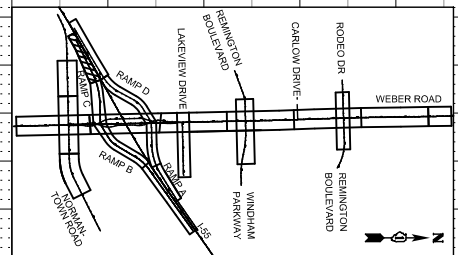
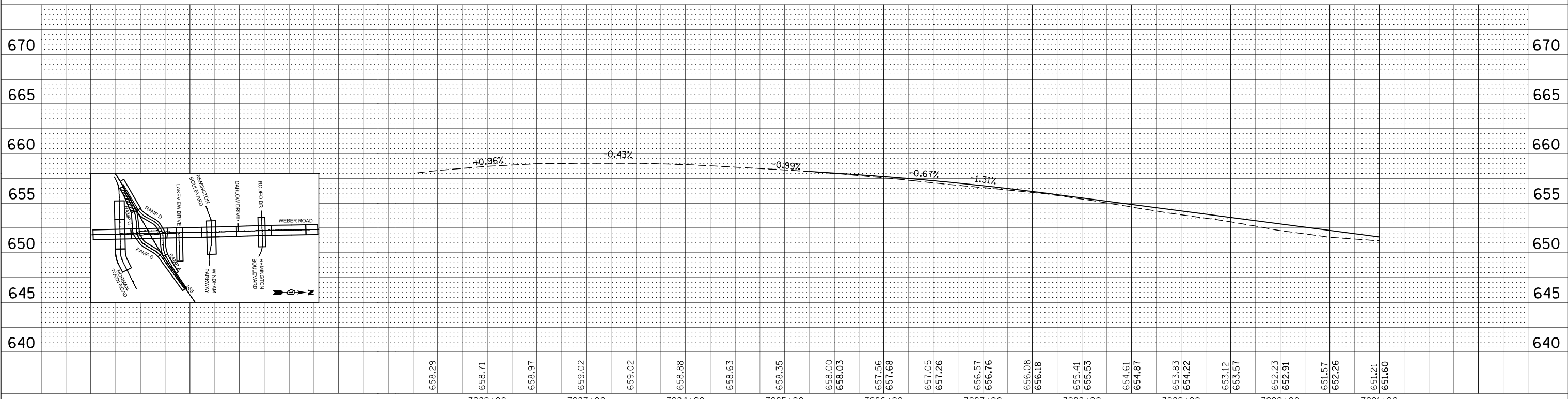
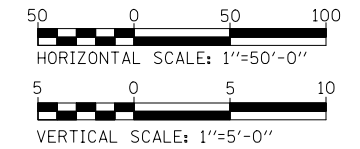
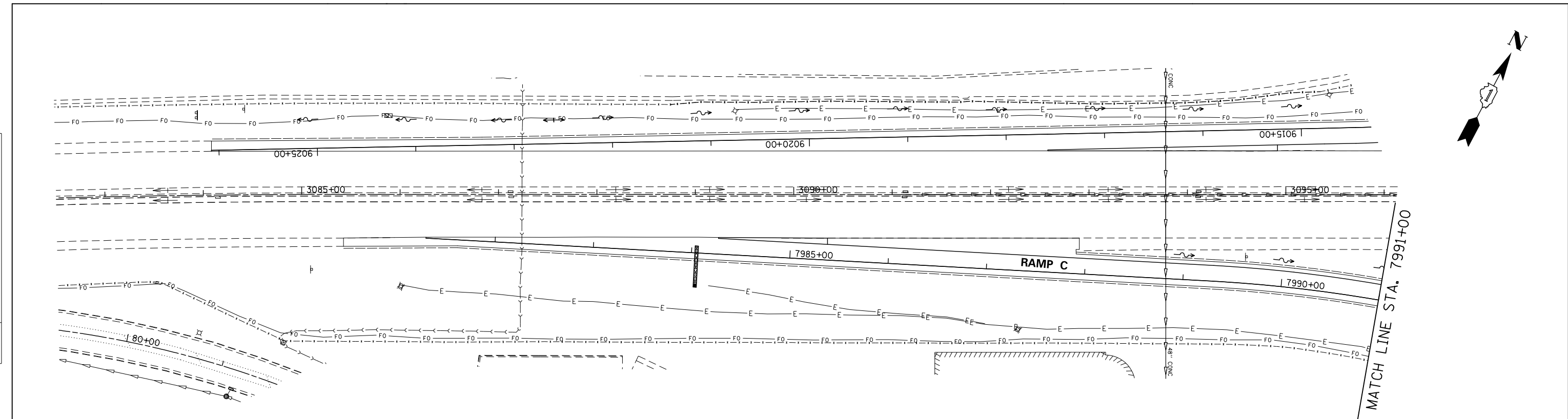

FILE NAME = D:\EX10-1\ht-d\aut19\proj\aut19-155 RampC.dgn



USER NAME = mmaestra	DESIGNED - REM	REVISED -
PLOT SCALE = 1:99,9998	DRAWN - DGB	REVISED -
PLOT DATE = 5/13/2017	CHECKED - PJO	REVISED -
	DATE - 05/12/17	REVISED -

**STATE OF ILLINOIS
DEPARTMENT OF TRANSPORTATION**

PROPOSED DRAINAGE PLAN & PROFILE - RAMP C

SCALE: 1" = 50' SHEET NO. 19 OF 22 SHEETS STA. 3085+43 TO STA. 7991+00

F.A.I./P RTE.	SECTION	COUNTY	TOTAL SHEETS	SHEET NO.
*	(99-1HB-1) R-1	WILL	1508	583
				CONTRACT NO. 60X10

* FAI 55, FAP 856 ILLINOIS FED. AID PROJECT

PLAN	SURVEYED	DATE
	PLOTTED	BY
	CHECKED	
	ALIGNED	
	FILED	
	NO.	

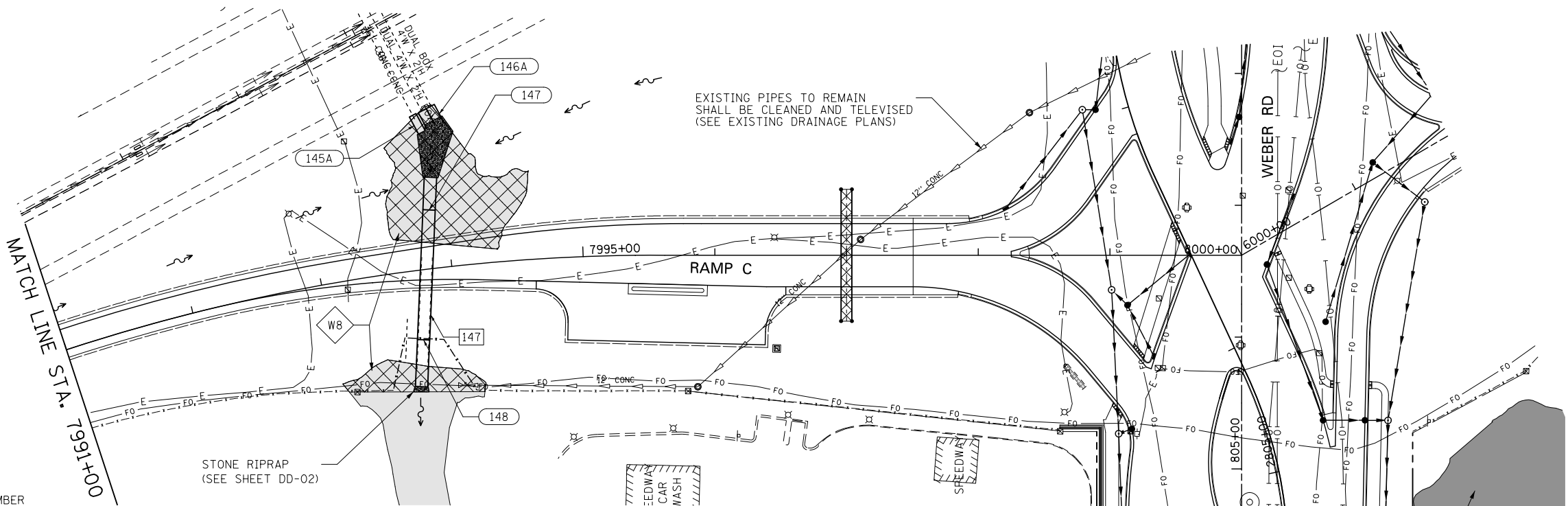

- WETLAND NUMBER
- ISOLATED WETLAND
- WATERS OF THE U.S. (WOUS)
- PERMANENT IMPACT AREA

TOTAL WETLAND AREA SITE 8 : 0.90 ACRES
 PERMANENT IMPACT AREA: 0.26 ACRES
 (SEE NORMANTOWN ROAD FOR ADDITIONAL IMPACTS TO SITE 8)

STATION	TO STATION	SIZE (SPAN X HEIGHT)	SKEW	DESIGN FILL (FT)		PGE BACKFILL REQ
				MINIMUM	MAXIMUM	
7993+88	7993+71	8' X 4'	9°	7.3	5.0	YES
45.0' LT		53.0' RT		LENGTH: 93 FT		

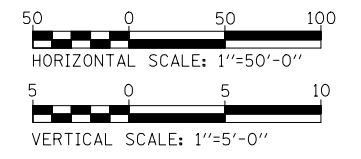

SEE DRAINAGE PLAN AND PROFILE SHEET 1 OF 22 FOR W15 DETAILS.

PROFILE	SURVEYED	DATE
	PLOTTED	BY
	CHECKED	
	GRADES	
	STRUCTURE	
	NOTATIONS	
	CPWD	
	NO.	

Freq. (Yr)	Q (cfs)	Opening (sq ft)		Nat. H.W.E. (ft)		Head (ft)		Headwater El.	
		Exist.	Prop.	Exist.	Prop.	Exist.	Prop.	Exist.	Prop.
2	44.45	3.28	3.28	640.82	0.77	0.83	641.59	641.65	

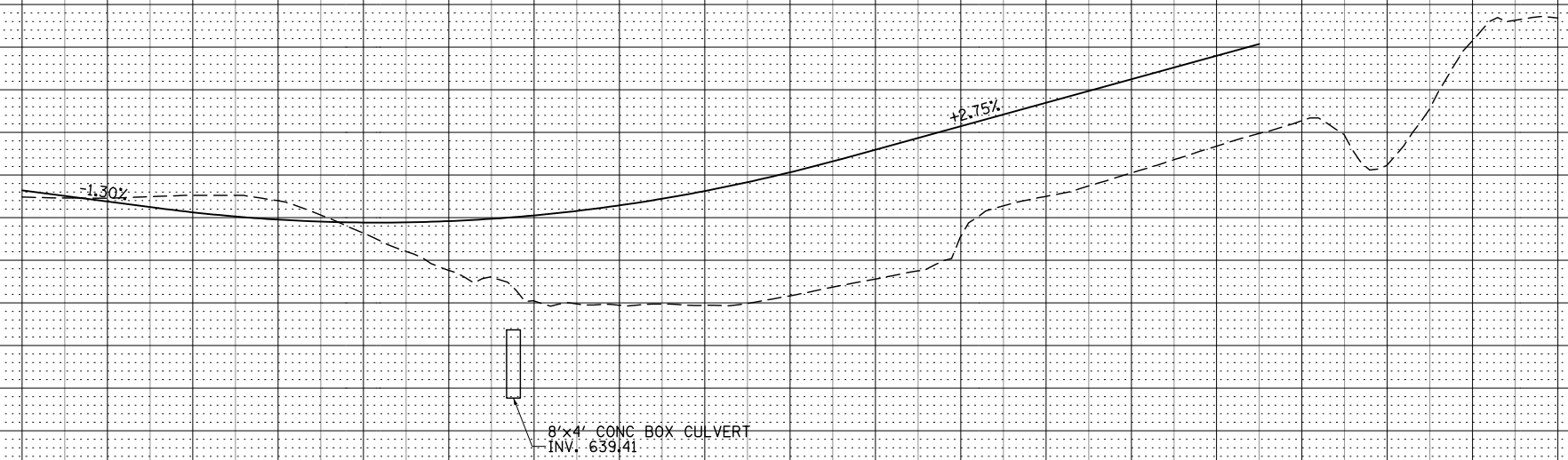
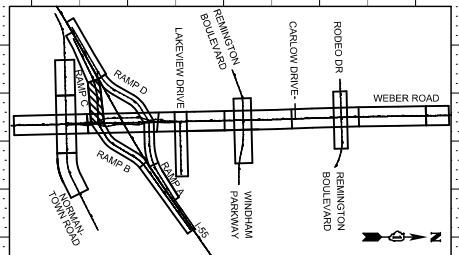

Flood	Freq. (Yr)	Q (cfs)	Opening (sq ft)		Nat. H.W.E. (ft)		Head (ft)		Headwater El.	
			Exist.	Prop.	Exist.	Prop.	Exist.	Prop.	Exist.	Prop.
10	93.1	6.80	6.80	641.26	1.63	1.75	642.89	643.01		
Design	50	170.7	9.68	9.68	641.62	2.78	2.79	644.40	644.41	
Base	100	211.85	11.04	11.04	641.79	3.53	3.54	645.32	645.33	
Overtop Ex.										
Overtop Pr.										
Max. Calc.	500									
EXISTING STRUCTURE		PROPOSED STRUCTURE								
Type:	RCB Box Culvert 8'(W) x 3'(H)	Type:	RCB Box Culvert 8'(W) x 4'(H)*							
Length:	86'-5"	Length:	86'-4"							
Span:	1	Span:	1							
U/S Invert:	640.41	U/S Invert:	640.41							
D/S Invert:	639.65	D/S Invert:	640.21							
Skew:	None	Skew:	None							

651.21	651.60	651.14	650.95	651.30	650.31	650.99	649.89	649.09	649.71	646.91	649.79	645.11	650.13	644.86	650.72	644.86	651.56	645.41	652.66	646.40	653.99	648.89	655.36	651.25	656.74	652.62	658.11	654.20	659.49	655.69	653.09	660.39	661.70
7991+00		7992+00		7993+00		7994+00		7995+00		7996+00		7997+00		7998+00		7999+00		8000+00															



USER NAME = mmaestra	DESIGNED - REM	REVISED -
PLOT SCALE = 1:99,998	DRAWN - DGB	REVISED -
PLOT DATE = 5/13/2017	CHECKED - PJO	REVISED -
	DATE - 05/12/17	REVISED -

STATE OF ILLINOIS
 DEPARTMENT OF TRANSPORTATION

PROPOSED DRAINAGE PLAN & PROFILE - RAMP C

SCALE: 1" = 50' SHEET NO. 20 OF 22 SHEETS STA. 7991+00 TO STA. 8000+00

F.A.I/P RTE.	SECTION	COUNTY	TOTAL SHEETS	SHEET NO.
*	(99-1HB-1) R-1	WILL	1508	584
CONTRACT NO. 60X10				

* FAI 55, FAP 856 ILLINOIS FED. AID PROJECT

FILE NAME = D:\BX10-shr-ct-ans-38-pr-dr-am-28-1B5 RampC.dgn

PLAN	SURVEYED	BY	DATE
	PLOTTED		
	CHECKED		
	ALIGNED		
	FILED		
NOTE BOOK NO.	FILE NAME		

PROFILE	SURVEYED	BY	DATE
	PLOTTED		
	CHECKED		
	STRUCTURE		
NOTE BOOK NO.	NOT AT THIS CHFD		

FILE NAME = D:\EX10-shr-ct-ans21-per-ans-21-155 RampD.dgn

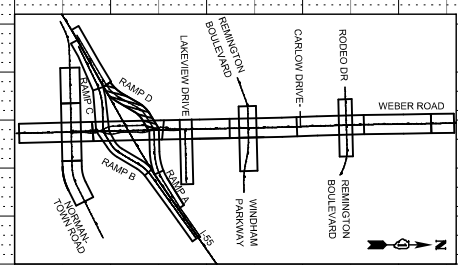
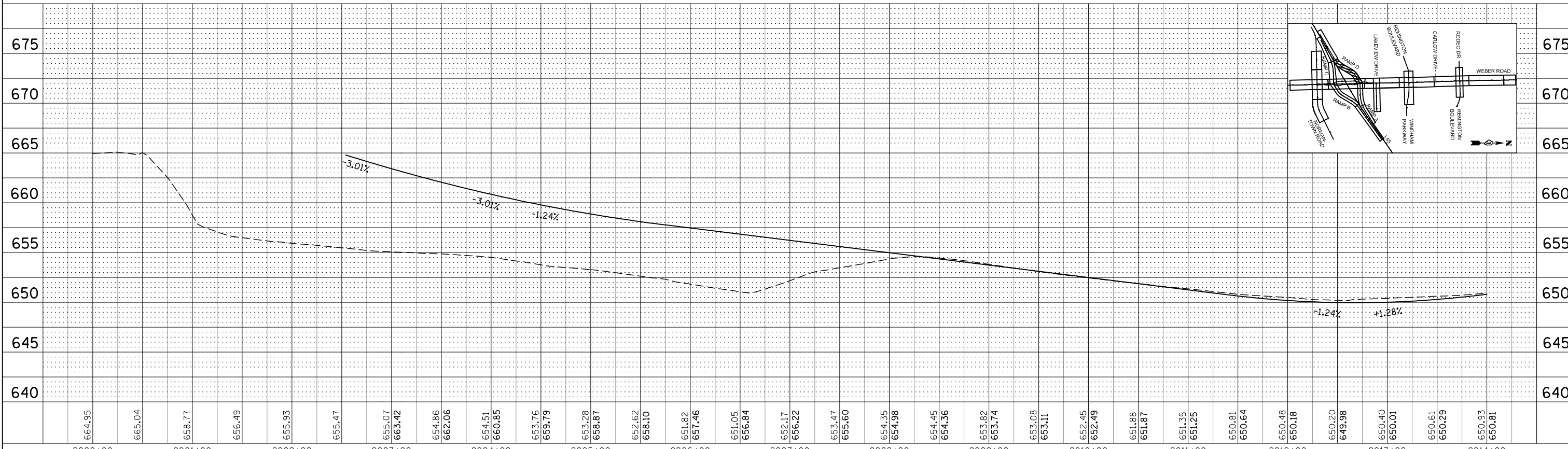
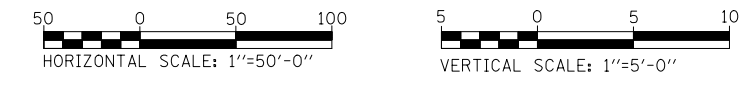
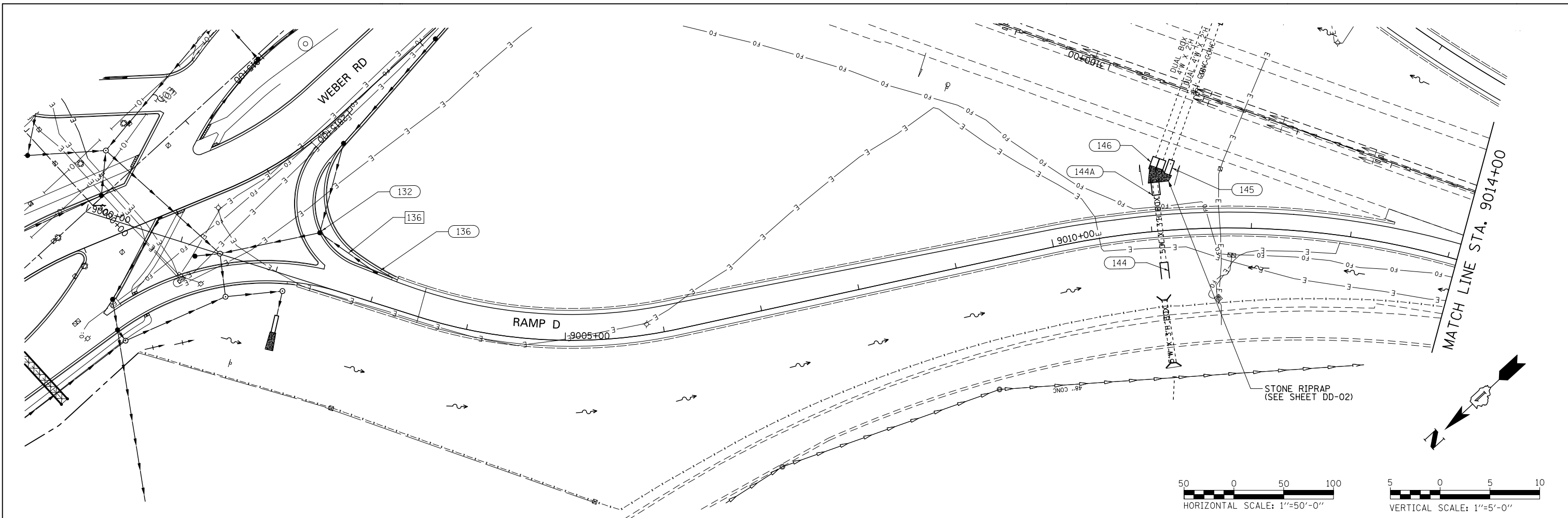

664.95	665.04	658.77	656.49	655.93	655.47	655.07	663.42	654.86	662.06	654.51	660.85	653.76	659.79	653.28	658.87	652.62	658.10	651.82	657.46	651.05	656.84	652.17	656.22	653.47	655.60	654.35	654.98	654.45	654.36	653.82	653.74	653.08	653.11	652.45	652.49	651.88	651.87	651.35	651.25	650.81	650.64	650.48	650.18	650.20	649.98	650.40	650.01	650.61	650.29	650.93	650.81
9000+00	9001+00	9002+00	9003+00	9004+00	9005+00	9006+00	9007+00	9008+00	9009+00	9010+00	9011+00	9012+00	9013+00	9014+00																																					



USER NAME = mmaestra	DESIGNED - REM	REVISED -
PLOT SCALE = 1:99,9998	DRAWN - DGB	REVISED -
PLOT DATE = 5/13/2017	CHECKED - PJO	REVISED -
	DATE - 05/12/17	REVISED -

STATE OF ILLINOIS
DEPARTMENT OF TRANSPORTATION

PROPOSED DRAINAGE PLAN & PROFILE - RAMP D

SCALE: 1" = 50' SHEET NO. 21 OF 22 SHEETS STA. 9000+00 TO STA. 9014+00

F.A.I./P RTE.	SECTION	COUNTY	TOTAL SHEETS	SHEET NO.
*	(99-1HB-1) R-1	WILL	1508	585
CONTRACT NO. 60X10			* FAI 55, FAP 856 ILLINOIS FED. AID PROJECT	

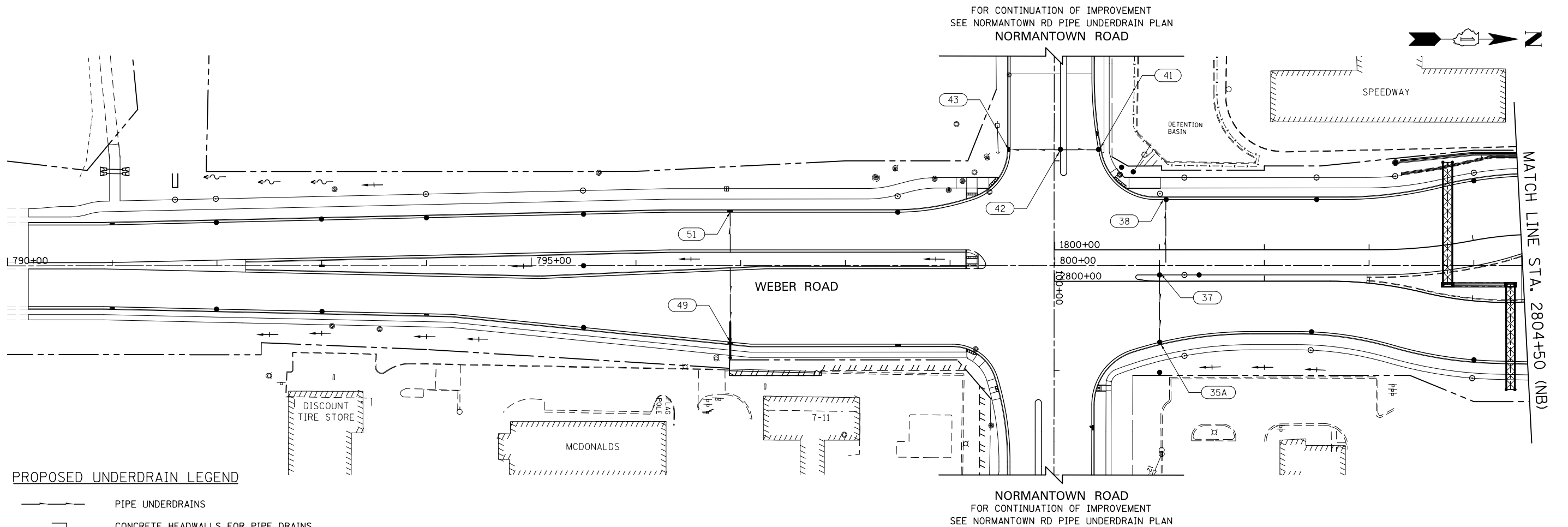

PROPOSED UNDERDRAIN LEGEND

- PIPE UNDERDRAINS
- CONCRETE HEADWALLS FOR PIPE DRAINS

FOR CONTINUATION OF IMPROVEMENT
SEE NORMANTOWN RD PIPE UNDERDRAIN PLAN
NORMANTOWN ROAD

NORMANTOWN ROAD
FOR CONTINUATION OF IMPROVEMENT
SEE NORMANTOWN RD PIPE UNDERDRAIN PLAN

MATCH LINE STA. 2804+50 (NB)

STRUCTURE NUMBER	FROM		TO		PIPE UNDERDRAINS, TYPE 2, 4" (FOOT)	PIPE UNDERDRAINS, 4" (SPECIAL) (FOOT)
	STATION	OFFSET	STRUCTURE NUMBER	STATION		
HIGH	796+90.0	13.0 LT	51	796+90.0	51.0 LT	39
HIGH	796+90.0	2.5 RT	49	796+90.0	73.0 RT	72
HIGH	2801+06.0	18.0 LT	38	1801+06.0	48.0 LT	60
HIGH	2801+00.0	18.0 LT	37	1801+00.0	24.0 RT	12
37	1801+00.0	24.0 RT	35A	2801+00.1	58.2 RT	64
HIGH	800+00.0	111.0 LT	43	799+57.0	111.0 LT	42
HIGH	800+00.0	111.0 LT	42	2800+05.0	126.0 LT	6
42	2800+05.0	126.0 LT	41	2800+42.0	126.0 LT	36
					SUBTOTAL	331 FT
						0 FT

NOTE:

PIPE UNDERDRAINS, TYPE 2, 4" SHALL BE PLACED AT A DEPTH OF 30" BELOW THE TOP OF PROPOSED PAVEMENT OR AS DEEP AS POSSIBLE.

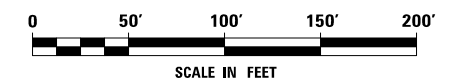
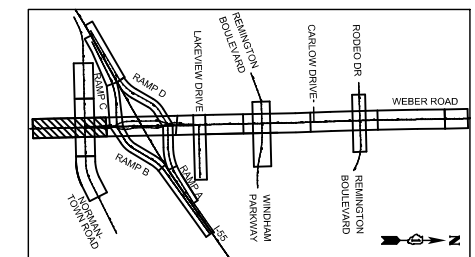

FILE NAME = D:\60X10-shr-drain\1-under-drain-01-weber.dgn

KNIGHT Engineers & Architects	USER NAME = mmaestra	DESIGNED REM	REVISED -
	PLOT SCALE = 1:100	DRAWN DGB	REVISED -
	PLOT DATE = 5/13/2017	CHECKED PJO	REVISED -
		DATE 05/12/17	REVISED -

**STATE OF ILLINOIS
DEPARTMENT OF TRANSPORTATION**

PIPE UNDERDRAIN PLAN - WEBER ROAD			
SCALE: AS SHOWN	SHEET NO. 1 OF 22 SHEETS	STA. 790+00 TO STA. 2804+50	

F.A.I./P RTE.	SECTION	COUNTY	TOTAL SHEETS	SHEET NO.
*	(99-1HB-1) R-1	WILL	1508	587
			CONTRACT NO. 60X10	
* FAI 55, FAP 856 ILLINOIS FED. AID PROJECT				

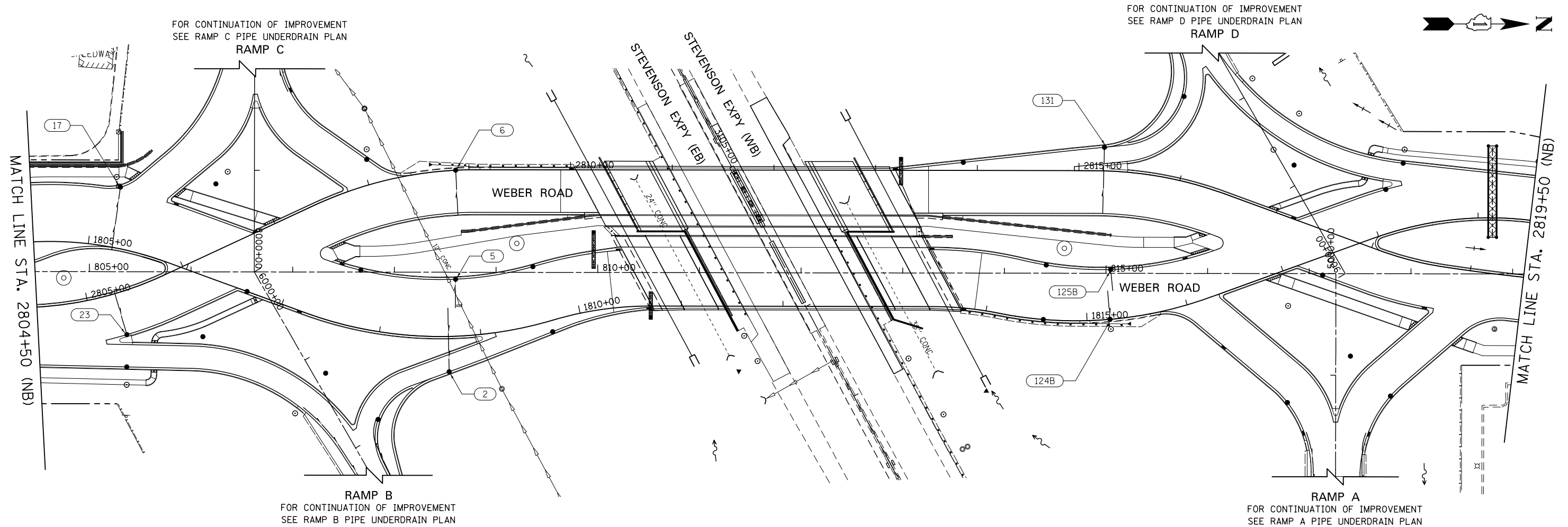

STRUCTURE NUMBER	FROM		TO		PIPE UNDERDRAINS, TYPE 2, 4" (FOOT)	PIPE UNDERDRAINS 4" (SPECIAL) (FOOT)
	STATION	OFFSET	STRUCTURE NUMBER	STATION		
HIGH	2805+38.7	42.6 LT	17	1805+21.3	59.6 LT	62
HIGH	2805+28.0	2.0 LT	23	2805+28.0	42.0 RT	43
HIGH	2808+87.0	44.0 RT	6	2808+86.9	0.0 LT	44
HIGH	2808+75.5	135.0 RT	5	1808+77.7	56.0 LT	28
HIGH	2808+63.9	134.6 RT	2	1808+68.2	34.8 RT	63
HIGH	2815+25.0	42.0 RT	131	2815+24.5	23.2 LT	65
HIGH	2815+42.0	117.3 RT	125B	1815+28.2	48.8 LT	21
HIGH	2815+34.6	118.0 RT	124B	1815+22.7	0.0 LT	28
					SUBTOTAL	354 FT
						0 FT

NOTE:
PIPE UNDERDRAINS, TYPE 2, 4" SHALL BE PLACED AT A DEPTH OF 30" BELOW THE TOP OF PROPOSED PAVEMENT OR AS DEEP AS POSSIBLE.

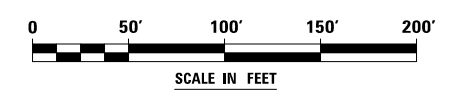
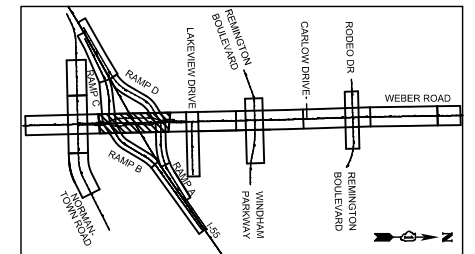

FILE NAME : D:\60X10-shr-drain02-underdrain-02-Weber.dgn

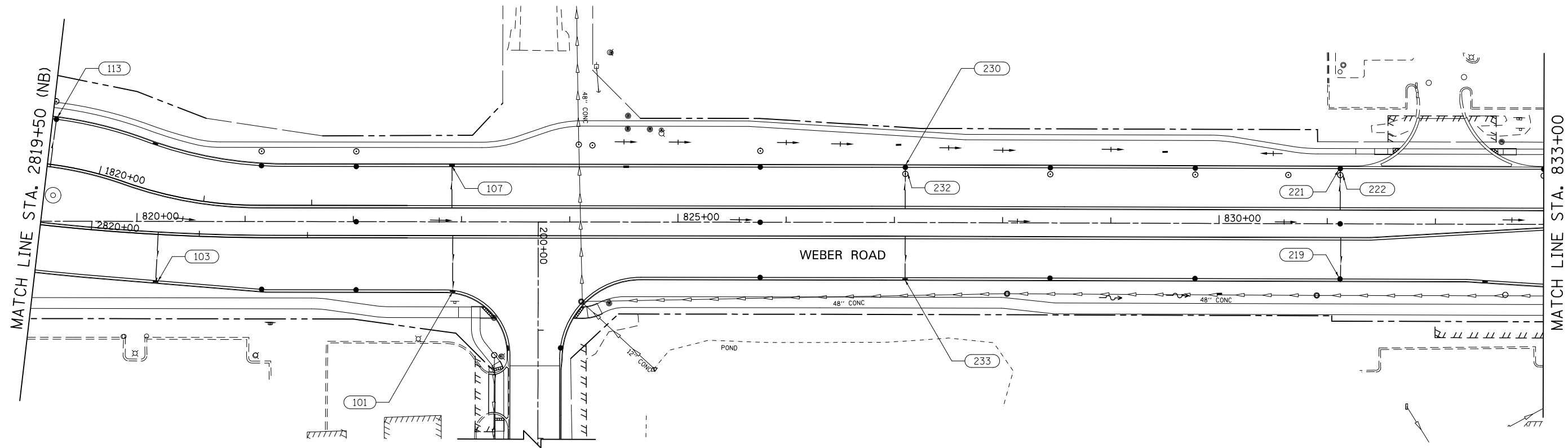

LAKEVIEW DRIVE
FOR CONTINUATION OF IMPROVEMENT
SEE LAKEVIEW DR PIPE UNDERDRAIN PLAN

STRUCTURE NUMBER	FROM		TO		PIPE UNDERDRAINS, TYPE 2, 4" (FOOT)	PIPE UNDERDRAINS, TYPE 2, 4" (SPECIAL) (FOOT)
	STATION	OFFSET	STRUCTURE NUMBER	STATION		
HIGH	2819+56.0	54.0 LT	113	2819+57.0	99.0 LT	44
HIGH	2820+62.0	2.0 LT	103	2820+62.0	43.0 RT	43
HIGH	822+91.0	13.0 LT	107	822+92.0	51.0 LT	37
HIGH	822+92.0	13.0 RT	101	822+92.0	63.0 RT	48
HIGH	827+10.0	13.0 LT	232	827+10.0	45.0 LT	30
	827+10.0	45.0 LT	230	827+10.0	51.0 LT	4
HIGH	827+10.0	13.0 RT	233	827+10.0	51.0 RT	36
HIGH	831+12.0	13.0 LT	222	831+12.0	45.0 LT	30
	831+12.0	45.0 LT	221	831+12.0	51.0 LT	4
HIGH	831+12.0	13.0 RT	219	831+12.0	51.0 RT	36
					SUBTOTAL	312 FT
						0 FT

NOTE:

PIPE UNDERDRAINS, TYPE 2, 4" SHALL BE PLACED AT A DEPTH OF 30" BELOW THE TOP OF PROPOSED PAVEMENT OR AS DEEP AS POSSIBLE.

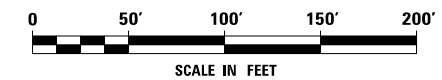
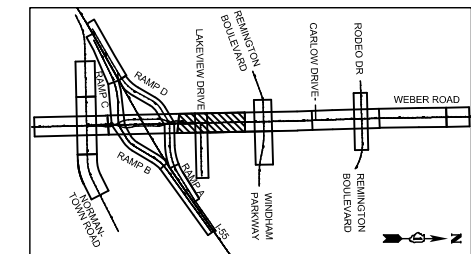

FILE NAME = D:\60X10-shr-drain-03-underdrain-03-Weber.dgn

KNIGHT
Engineers & Architects

USER NAME = mmaestra	DESIGNED REM	REVISED -
DRAWN DGB	REVISIONS	REVISED -
PLOT SCALE = 1:100	CHECKED PJO	REVISED -
PLOT DATE = 5/13/2017	DATE 05/12/17	REVISED -

**STATE OF ILLINOIS
DEPARTMENT OF TRANSPORTATION**

PIPE UNDERDRAIN PLAN - WEBER ROAD

SCALE: AS SHOWN SHEET NO. 3 OF 22 SHEETS STA. 2819+50 TO STA. 833+00

F.A.I./P. RTE.	SECTION	COUNTY	TOTAL SHEETS	SHEET NO.
*	(99-1HB-1) R-1	WILL	1508	589
			CONTRACT NO. 60X10	
* FAI 55, FAP 856 ILLINOIS FED. AID PROJECT				

FOR CONTINUATION OF IMPROVEMENT
SEE REMINGTON BLVD PIPE UNDERDRAIN PLAN
REMINGTON BOULEVARD

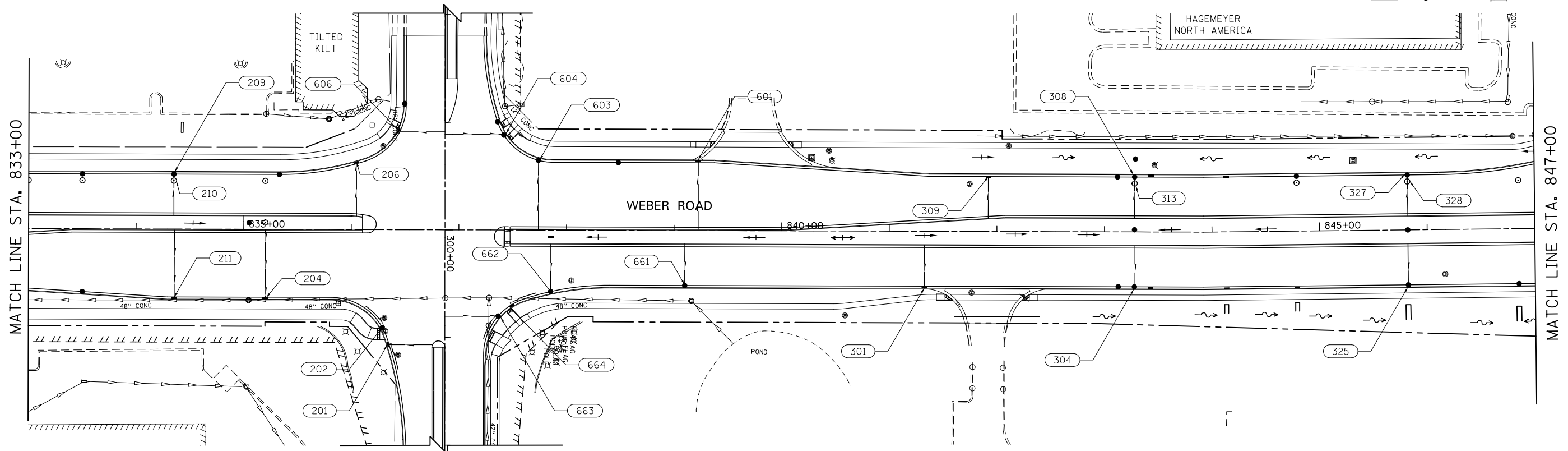

WINDHAM PARKWAY
FOR CONTINUATION OF IMPROVEMENT
SEE WINDHAM PKWY PIPE UNDERDRAIN PLAN

STRUCTURE NUMBER	FROM		TO		PIPE UNDERDRAINS, TYPE 2, 4" (FOOT)	PIPE UNDERDRAINS (SPECIAL) 4" (FOOT)	
	STATION	OFFSET	STRUCTURE NUMBER	STATION			OFFSET
HIGH	834+35.0	13.0 LT	210	834+35.0	45.0 LT	30	
210	834+35.0	45.0 LT	209	834+35.0	51.0 LT	4	
HIGH	834+36.0	1.0 RT	211	834+36.0	63.0 RT	60	
HIGH	836+05.0	12.6 LT	206	836+05.0	61.0 LT	47	
HIGH	835+20.0	0.4 RT	204	835+20.0	63.0 RT	61	
HIGH	837+73.0	1.0 LT	603	837+73.0	65.0 LT	62	
HIGH	837+85.0	13.0 RT	662	837+85.0	57.0 RT	42	
HIGH	839+22.0	1.0 LT	601	839+22.0	63.0 LT	60	
HIGH	839+10.0	13.0 RT	661	839+15.0	51.0 RT	37	
HIGH	841+92.0	12.1 LT	309	841+92.0	51.0 LT	37	
HIGH	841+33.0	13.0 RT	301	841+33.0	51.0 RT	36	
HIGH	843+28.0	12.4 LT	313	843+28.0	45.0 LT	31	
313	843+28.0	45.0 LT	308	843+28.0	51.0 LT	4	
HIGH	843+28.0	13.0 RT	304	843+28.0	51.0 RT	36	
HIGH	845+82.0	13.0 LT	328	845+82.0	45.0 LT	30	
328	845+82.0	45.0 LT	327	845+82.0	51.0 LT	4	
HIGH	845+82.0	13.0 RT	325	845+82.0	51.0 RT	36	
HIGH	836+87.0	91.0 LT	606	836+45.0	91.0 LT	40	
HIGH	836+87.0	88.0 LT	604	837+42.0	88.0 LT	53	
HIGH	836+14.0	71.0 RT	202	836+29.0	97.0 RT	25	
HIGH	836+75.0	106.6 RT	201	836+35.0	107.0 RT	39	
HIGH	836+44.0	130.6 RT	201	836+35.0	107.0 RT	25	
HIGH	837+72.0	60.2 RT	664	837+48.0	70.0 RT	25	
HIGH	836+87.0	80.2 RT	663	837+37.0	79.0 RT	49	
HIGH	837+23.0	101.3 RT	663	837+37.0	79.0 RT	25	
					SUBTOTAL	898 FT	0 FT

NOTE:

PIPE UNDERDRAINS, TYPE 2, 4" SHALL BE PLACED AT A DEPTH OF 30" BELOW THE TOP OF PROPOSED PAVEMENT OR AS DEEP AS POSSIBLE.

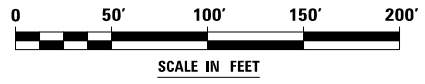
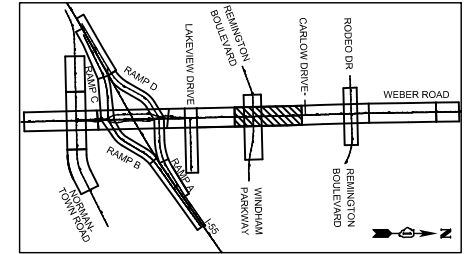

FILE NAME = D:\60X10-shr-drain\04-underdrain-04-Weber.dgn

KNIGHT Engineers & Architects	USER NAME = mmaestra	DESIGNED REM	REVISED -
	PLOT SCALE = 1:100	DRAWN DGB	REVISED -
	DATE = 5/13/2017	CHECKED PJO	REVISED -
		DATE 05/12/17	REVISED -

STATE OF ILLINOIS
DEPARTMENT OF TRANSPORTATION

PIPE UNDERDRAIN PLAN - WEBER ROAD

SCALE: AS SHOWN SHEET NO. 4 OF 22 SHEETS STA. 833+00 TO STA. 847+00

F.A.I./P. RTE.	SECTION	COUNTY	TOTAL SHEETS	SHEET NO.
*	(99-1HB-1) R-1	WILL	1508	590
* FAI 55, FAP 856 [ILLINOIS] FED. AID PROJECT			CONTRACT NO. 60X10	

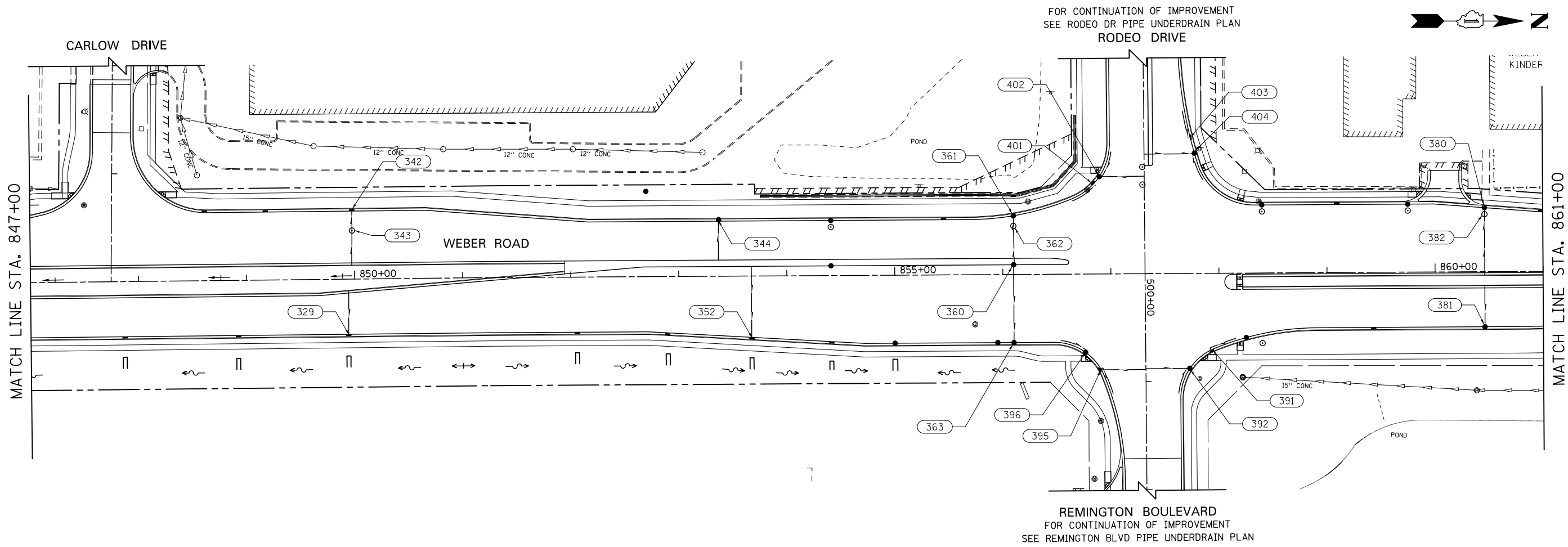

FOR CONTINUATION OF IMPROVEMENT
SEE RODEO DR PIPE UNDERDRAIN PLAN
RODEO DRIVE

REMINGTON BOULEVARD
FOR CONTINUATION OF IMPROVEMENT
SEE REMINGTON BLVD PIPE UNDERDRAIN PLAN

STRUCTURE NUMBER	FROM		TO		PIPE UNDERDRAINS, TYPE 2, 4" (FOOT)	PIPE UNDERDRAINS 4" (SPECIAL) (FOOT)	
	STATION	OFFSET	STRUCTURE NUMBER	STATION			OFFSET
HIGH	849+98.0	13.0 LT	343	849+98.0	45.0 LT	30	
343	849+98.0	45.0 LT	342	849+98.0	63.0 LT	16	
HIGH	849+94.0	10.9 RT	329	849+94.0	51.0 RT	39	
HIGH	853+37.0	14.9 LT	344	853+37.0	51.0 LT	35	
HIGH	853+67.0	9.0 LT	352	853+67.0	57.0 RT	64	
HIGH	856+10.0	3.0 RT	360	856+10.0	9.0 LT	10	
360	856+10.0	9.0 LT	362	856+10.0	45.0 LT	34	
HIGH	856+10.0	45.0 LT	361	856+10.0	54.0 LT	7	
HIGH	856+10.0	3.0 RT	363	856+10.0	63.0 RT	58	
HIGH	860+46.0	3.0 RT	382	860+46.0	53.0 LT	54	
382	860+46.0	53.0 LT	380	860+46.0	59.0 LT	4	
HIGH	860+46.0	13.0 RT	381	860+46.0	51.0 RT	36	
HIGH	856+65.0	70.2 LT	401	856+85.0	84.0 LT	25	
HIGH	857+31.3	90.0 LT	402	856+90.0	90.0 LT	40	
HIGH	857+00.0	113.0 LT	402	856+90.0	90.0 LT	24	
HIGH	857+69.0	150.0 LT	403	857+74.0	126.0 LT	25	
HIGH	857+87.0	86.8 LT	404	857+78.0	112.0 LT	25	
HIGH	857+31.3	112.0 LT	404	857+78.0	112.0 LT	45	
HIGH	856+53.0	63.0 RT	396	856+76.0	72.0 RT	23	
HIGH	857+31.8	88.0 RT	395	856+90.0	88.0 RT	40	
HIGH	857+01.5	110.5 RT	395	856+90.0	88.0 RT	24	
HIGH	858+15.0	60.4 RT	391	857+92.0	71.0 RT	24	
HIGH	857+31.8	88.0 RT	392	857+73.0	88.0 RT	40	
HIGH	857+62.2	110.9 RT	392	857+73.0	88.0 RT	24	
					SUBTOTAL	746 FT	0 FT

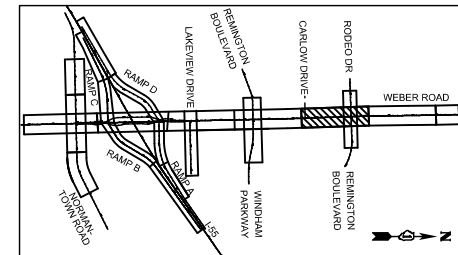

NOTE:
PIPE UNDERDRAINS, TYPE 2, 4" SHALL BE PLACED AT A DEPTH OF 30" BELOW THE TOP OF PROPOSED PAVEMENT OR AS DEEP AS POSSIBLE.

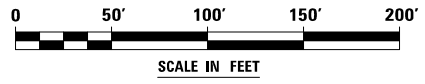

FILE NAME : D:\60X10-shr-drain05-underdrain-05-Weber.dgn

KNIGHT Engineers & Architects	USER NAME = mmaestra	DESIGNED REM	REVISED -
	PLOT SCALE = 1:1000	DRAWN DGB	REVISED -
	PLOT DATE = 5/15/2017	CHECKED PJO	REVISED -
		DATE 05/12/17	REVISED -

**STATE OF ILLINOIS
DEPARTMENT OF TRANSPORTATION**

PIPE UNDERDRAIN PLAN - WEBER ROAD

SCALE: AS SHOWN | SHEET NO. 5 OF 22 SHEETS | STA. 847+00 TO STA. 861+00

F.A./P RTE.	SECTION	COUNTY	TOTAL SHEETS	SHEET NO.
*	(99-1HB-1) R-1	WILL	1508	591
CONTRACT NO. 60X10				
* FAI 55, FAP 856 [ILLINOIS] FED. AID PROJECT				

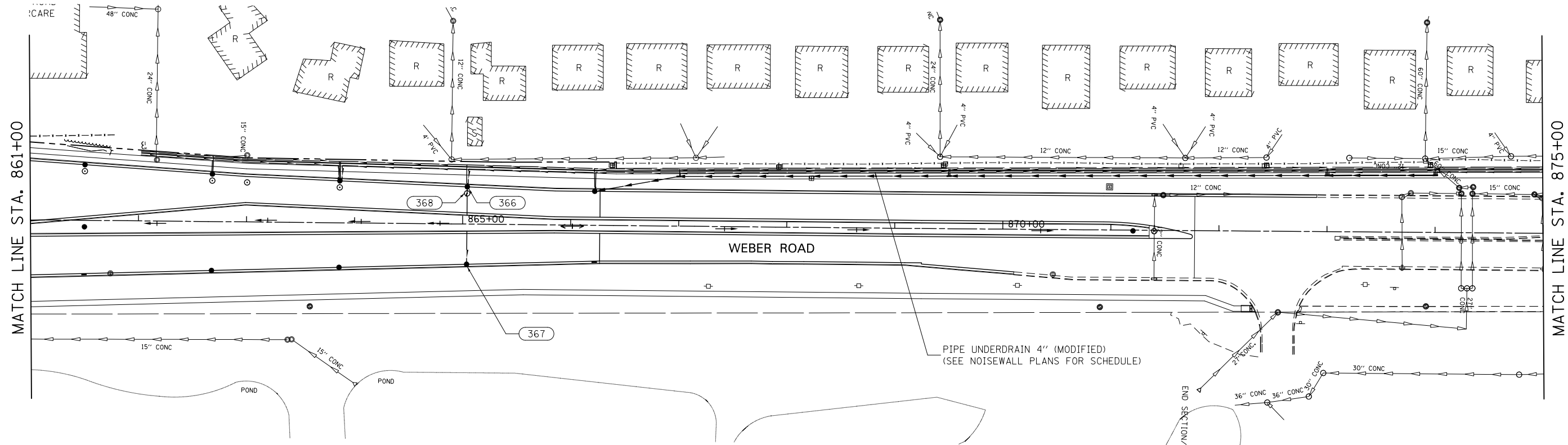

STRUCTURE NUMBER	FROM		TO		PIPE UNDERDRAINS, TYPE 2, 4" (FOOT)	PIPE UNDERDRAINS, TYPE 4" (SPECIAL) (FOOT)	
	STATION	OFFSET	STRUCTURE NUMBER	STATION			OFFSET
HIGH	865+04.0	7.9 LT	368	865+04.0	28.0 LT	19	
368	865+04.0	28.0 LT	366	865+04.0	34.0 LT	4	
HIGH	865+04.0	6.0 RT	367	865+04.0	37.0 RT	29	
					SUBTOTAL	52 FT	0 FT

NOTE:
 PIPE UNDERDRAINS, TYPE 2, 4" SHALL BE PLACED AT A DEPTH OF 30" BELOW THE TOP OF PROPOSED PAVEMENT OR AS DEEP AS POSSIBLE.

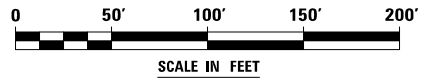
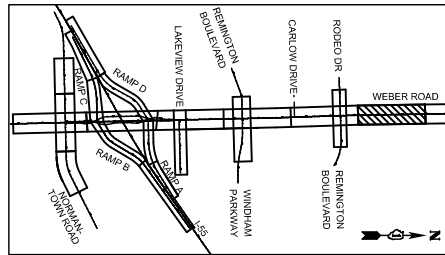

FILE NAME = D:\60X10-shr-drain06-underdrain-06-Weber.dgn



USER NAME = mmaestra	DESIGNED REM	REVISED -
DRAWN DGB	REVISOR	REVISED -
PLOT SCALE = 1:100	CHECKED PJO	REVISED -
PLOT DATE = 5/13/2017	DATE 05/12/17	REVISED -

**STATE OF ILLINOIS
 DEPARTMENT OF TRANSPORTATION**

PIPE UNDERDRAIN PLAN - WEBER ROAD

SCALE: AS SHOWN SHEET NO. 6 OF 22 SHEETS STA. 861+00 TO STA. 875+00

F.A.I./P RTE.	SECTION	COUNTY	TOTAL SHEETS	SHEET NO.
*	(99-1HB-1) R-1	WILL	1508	592
CONTRACT NO. 60X10				
* FAI 55, FAP 856 ILLINOIS FED. AID PROJECT				

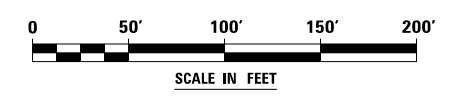
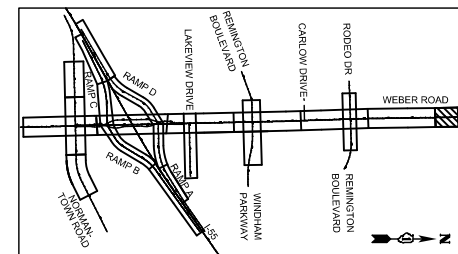
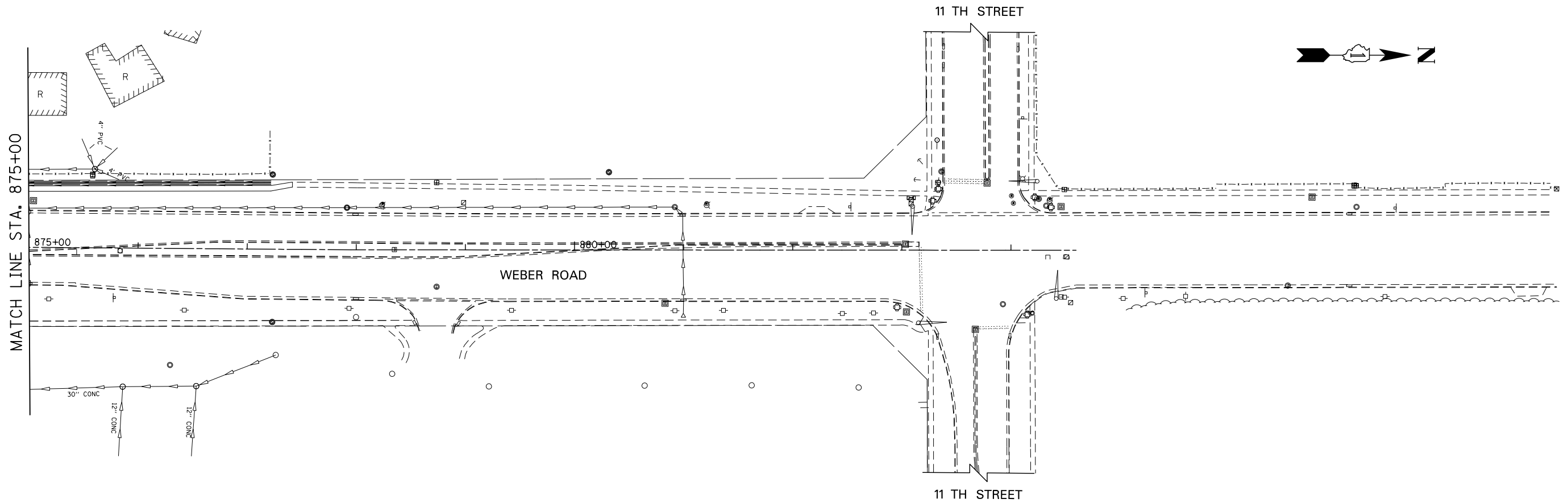

FILE NAME : D:\60X10-shr-drain\07-underdrain-07-Weber.dgn

KNIGHT
Engineers & Architects

USER NAME = mmaestra	DESIGNED REM	REVISED -
DRAWN DGB	REVISIONS	REVISED -
PLOT SCALE = 1:100	CHECKED PJO	REVISED -
PLOT DATE = 5/13/2017	DATE 05/12/17	REVISED -

**STATE OF ILLINOIS
DEPARTMENT OF TRANSPORTATION**

PIPE UNDERDRAIN PLAN - WEBER ROAD

SCALE: AS SHOWN SHEET NO. 7 OF 22 SHEETS STA. 875+00 TO STA. 877+41

F.A.I./P RTE.	SECTION	COUNTY	TOTAL SHEETS	SHEET NO.
*	(99-1HB-1) R-1	WILL	1508	593
CONTRACT NO. 60X10				
* FAI 55, FAP 856 [ILLINOIS] FED. AID PROJECT				

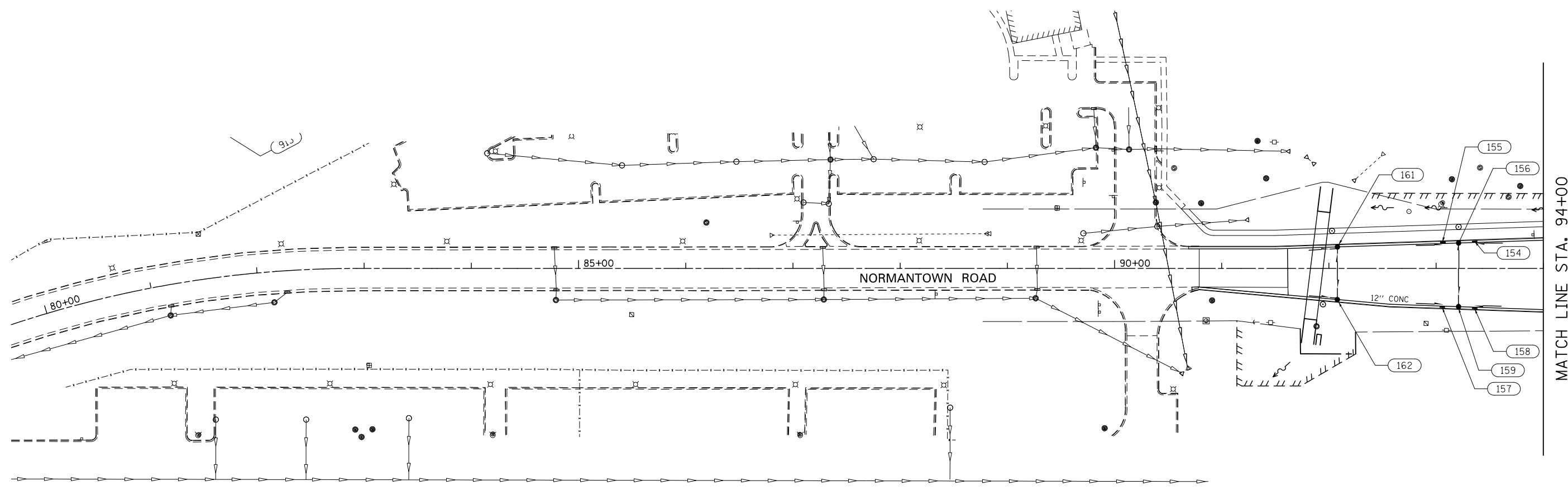

MATCH LINE STA. 94+00

STRUCTURE NUMBER	FROM		TO		PIPE UNDERDRAINS, TYPE 2, 4" (FOOT)	PIPE UNDERDRAINS 4" (SPECIAL) (FOOT)	
	STATION	OFFSET	STRUCTURE NUMBER	STATION			OFFSET
HIGH	92+08.0	0.0 LT	161	92+08.0	20.0 LT	18	
HIGH	91+83.0	20.0 LT	161	92+08.0	20.0 LT	25	
HIGH	92+08.0	0.0 LT	162	92+08.0	29.0 RT	27	
HIGH	91+83.0	29.0 RT	162	92+08.0	29.0 RT	25	
HIGH	92+81.0	35.0 RT	157	93+06.0	35.0 RT	25	
HIGH	92+81.0	23.0 LT	155	93+06.0	23.0 LT	25	
HIGH	93+21.0	0.0 LT	156	93+21.0	24.0 LT	22	
HIGH	93+21.0	0.0 LT	159	93+21.0	36.0 RT	33	
HIGH	93+61.0	36.0 RT	158	93+36.0	36.0 RT	25	
HIGH	93+61.0	24.0 LT	154	93+36.0	24.0 LT	25	
					SUBTOTAL	250 FT	0 FT

NOTE:
 PIPE UNDERDRAINS, TYPE 2, 4" SHALL BE PLACED AT A DEPTH OF 30" BELOW THE TOP OF PROPOSED PAVEMENT OR AS DEEP AS POSSIBLE.

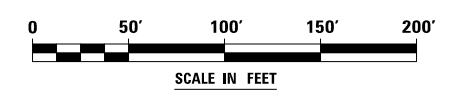
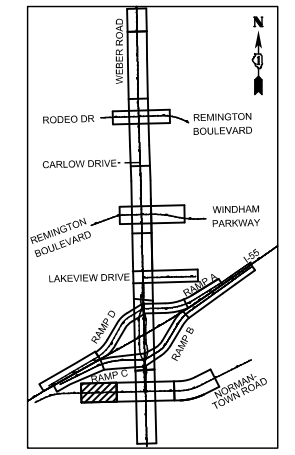

FILE NAME = D:\60X10-shr-drain\08-underdrain-08-Normantown.dgn

KNIGHT Engineers & Architects	USER NAME = mmaestra	DESIGNED REM	REVISED -
	PLOT SCALE = 1:100	DRAWN DGB	REVISED -
	PLOT DATE = 5/13/2017	CHECKED PJO	REVISED -
		DATE 05/12/17	REVISED -

**STATE OF ILLINOIS
 DEPARTMENT OF TRANSPORTATION**

**PIPE UNDERDRAIN PLAN
 NORMANTOWN ROAD**

SCALE: AS SHOWN SHEET NO. 8 OF 22 SHEETS STA. 90+79 TO STA. 94+00

F.A.I./P. RTE.	SECTION	COUNTY	TOTAL SHEETS	SHEET NO.
*	(99-1HB-1) R-1	WILL	1508	594
CONTRACT NO. 60X10				
* FAI 55, FAP 856 [ILLINOIS] FED. AID PROJECT				

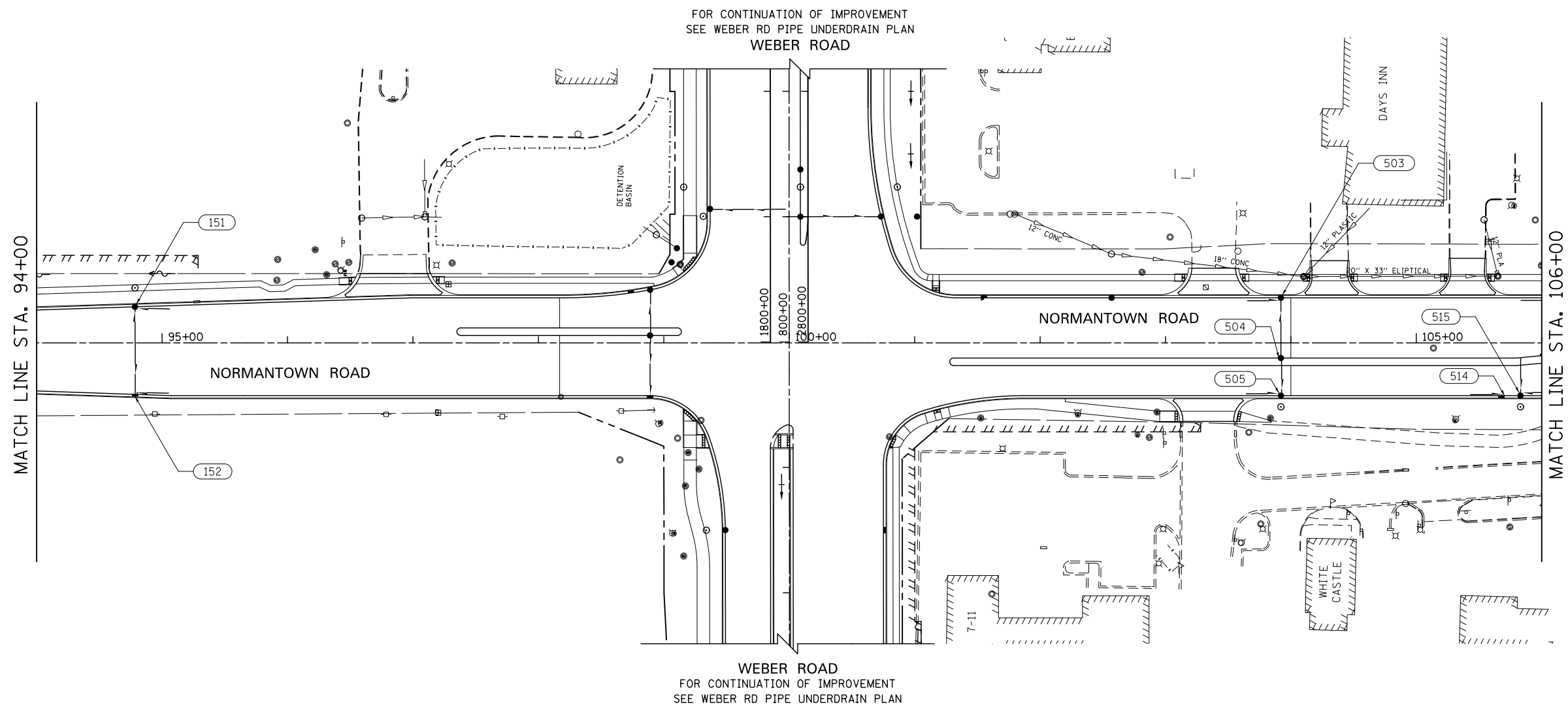

FOR CONTINUATION OF IMPROVEMENT
SEE WEBER RD PIPE UNDERDRAIN PLAN
WEBER ROAD

WEBER ROAD
FOR CONTINUATION OF IMPROVEMENT
SEE WEBER RD PIPE UNDERDRAIN PLAN

STRUCTURE NUMBER	FROM		TO		PIPE UNDERDRAINS, TYPE 2, 4" (FOOT)	PIPE UNDERDRAINS, 4" (SPECIAL) (FOOT)	
	STATION	OFFSET	STRUCTURE NUMBER	STATION			OFFSET
HIGH	94+78.0	0.0 LT	151	94+78.0	29.0 LT	27	
HIGH	94+79.0	0.0 LT	152	94+79.0	41.0 RT	40	
HIGH	95+03.0	29.0 LT	151	94+78.0	29.0 LT	25	
HIGH	95+03.0	41.0 RT	152	94+79.0	41.0 RT	25	
HIGH	103+92.0	0.0 LT	503	103+92.0	36.0 LT	34	
HIGH	103+67.0	36.0 LT	503	103+92.0	36.0 LT	25	
HIGH	103+67.0	42.0 RT	505	103+92.0	42.0 RT	25	
HIGH	103+92.0	0.0 LT	504	103+92.0	12.0 RT	10	
504	103+92.0	12.0 RT	505	103+92.0	42.0 RT	28	
HIGH	105+43.0	42.0 RT	514	105+68.0	42.0 RT	23	
HIGH	106+08.0	42.0 RT	515	105+83.0	42.0 RT	23	
HIGH	105+83.0	12.0 RT	515	105+83.0	42.0 RT	28	
					SUBTOTAL	313 FT	0 FT

NOTE:
PIPE UNDERDRAINS, TYPE 2, 4" SHALL BE PLACED AT A DEPTH OF 30" BELOW THE TOP OF PROPOSED PAVEMENT OR AS DEEP AS POSSIBLE.

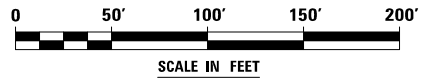
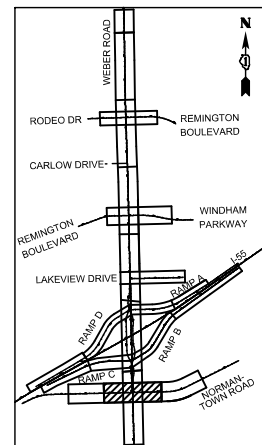

FILE NAME : D:\60X10-shit-drain-09-underdrain-09-Normantown.dgn

KNIGHT Engineers & Architects	USER NAME = mmaestra	DESIGNED REM	REVISED -
	PLOT SCALE = 1:100	DRAWN DGB	REVISED -
	PLOT DATE = 5/13/2017	CHECKED PJO	REVISED -
		DATE 05/12/17	REVISED -

**STATE OF ILLINOIS
DEPARTMENT OF TRANSPORTATION**

**PIPE UNDERDRAIN PLAN
NORMANTOWN ROAD**

SCALE: AS SHOWN SHEET NO. 9 OF 22 SHEETS STA. 94+00 TO STA. 106+00

F.A.I./P RTE.	SECTION	COUNTY	TOTAL SHEETS	SHEET NO.
*	(99-1HB-1) R-1	WILL	1508	595
CONTRACT NO. 60X10				
* FAI 55, FAP 856 [ILLINOIS] FED. AID PROJECT				

MATCH LINE STA. 106+00

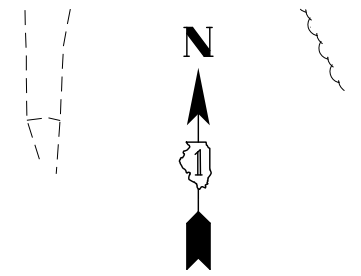
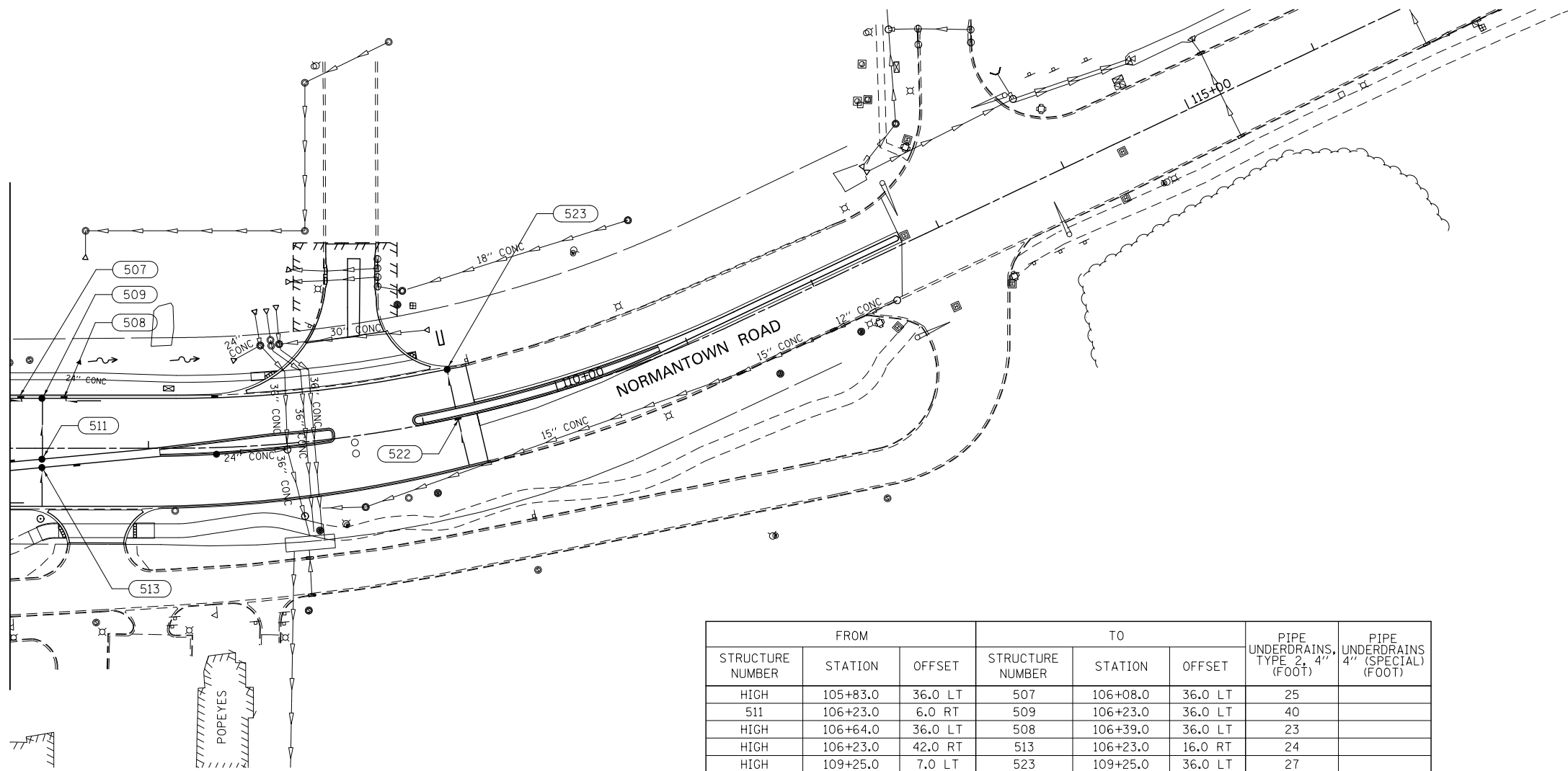

STRUCTURE NUMBER	FROM		TO		PIPE UNDERDRAINS, TYPE 2, 4\" (FOOT)	PIPE UNDERDRAINS, 4\" (SPECIAL) (FOOT)	
	STATION	OFFSET	STRUCTURE NUMBER	STATION			OFFSET
HIGH	105+83.0	36.0 LT	507	106+08.0	36.0 LT	25	
511	106+23.0	6.0 RT	509	106+23.0	36.0 LT	40	
HIGH	106+64.0	36.0 LT	508	106+39.0	36.0 LT	23	
HIGH	106+23.0	42.0 RT	513	106+23.0	16.0 RT	24	
HIGH	109+25.0	7.0 LT	523	109+25.0	36.0 LT	27	
HIGH	109+25.0	35.4 RT	522	109+25.0	0.0 LT	33	
					SUBTOTAL	172 FT	0 FT

NOTE:

PIPE UNDERDRAINS, TYPE 2, 4\" SHALL BE PLACED AT A DEPTH OF 30\" BELOW THE TOP OF PROPOSED PAVEMENT OR AS DEEP AS POSSIBLE.

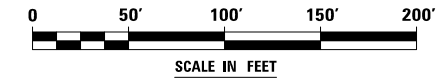
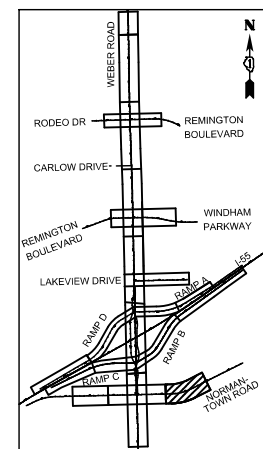

FILE NAME : D:\60X10-shd-drain\0-under-drain\10-Normantown.dgn

KNIGHT Engineers & Architects	USER NAME = mmaestra	DESIGNED REM	REVISED -
	PLOT SCALE = 1:100	DRAWN DGB	REVISED -
	PLOT DATE = 5/13/2017	CHECKED PJO	REVISED -
		DATE 05/12/17	REVISED -

**STATE OF ILLINOIS
DEPARTMENT OF TRANSPORTATION**

**PIPE UNDERDRAIN PLAN
NORMANTOWN ROAD**

SCALE: AS SHOWN SHEET NO. 10 OF 22 SHEETS STA. 106+00 TO STA. 112+71

F.A.I./P RTE.	SECTION	COUNTY	TOTAL SHEETS	SHEET NO.
*	(99-1HB-1) R-1	WILL	1508	596
CONTRACT NO. 60X10				
* FAI 55, FAP 856 [ILLINOIS] FED. AID PROJECT				

FOR CONTINUATION OF IMPROVEMENT
SEE WEBER RD PIPE UNDERDRAIN PLAN
WEBER ROAD

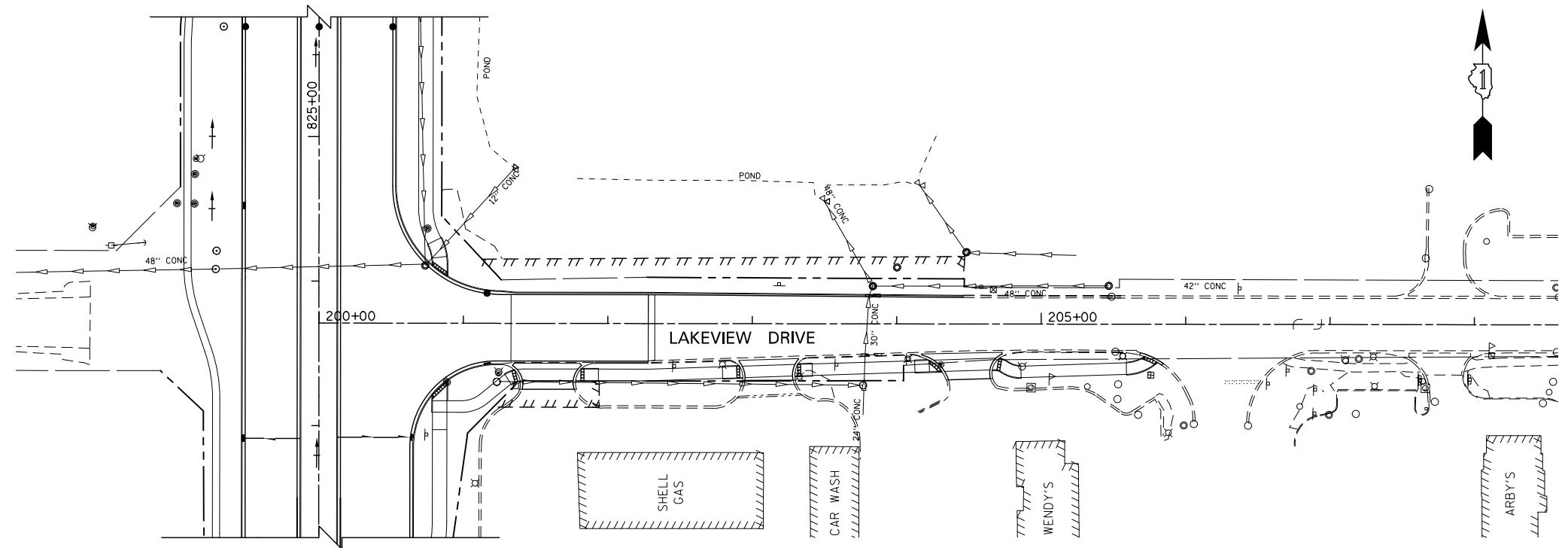

WEBER ROAD
FOR CONTINUATION OF IMPROVEMENT
SEE WEBER RD PIPE UNDERDRAIN PLAN

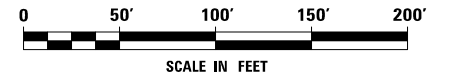
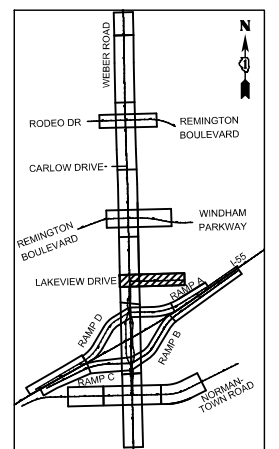

FILE NAME = D:\60X10-shr-drain\1-underdrain-1-lakeview.dgn



USER NAME = mmaestra	DESIGNED REM	REVISED -
	DRAWN DGB	REVISED -
PLOT SCALE = 1:100	CHECKED PJO	REVISED -
PLOT DATE = 5/13/2017	DATE 05/12/17	REVISED -

STATE OF ILLINOIS
DEPARTMENT OF TRANSPORTATION

PIPE UNDERDRAIN PLAN
LAKEVIEW DRIVE

SCALE: AS SHOWN SHEET NO. 11 OF 22 SHEETS STA. 200+00 TO STA. 205+42

F.A.I./P RTE.	SECTION	COUNTY	TOTAL SHEETS	SHEET NO.
*	(99-1HB-1) R-1	WILL	1508	597
			CONTRACT NO. 60X10	
* FAI 55, FAP 856 ILLINOIS FED. AID PROJECT				

FOR CONTINUATION OF IMPROVEMENT
SEE WEBER RD PIPE UNDERDRAIN PLAN

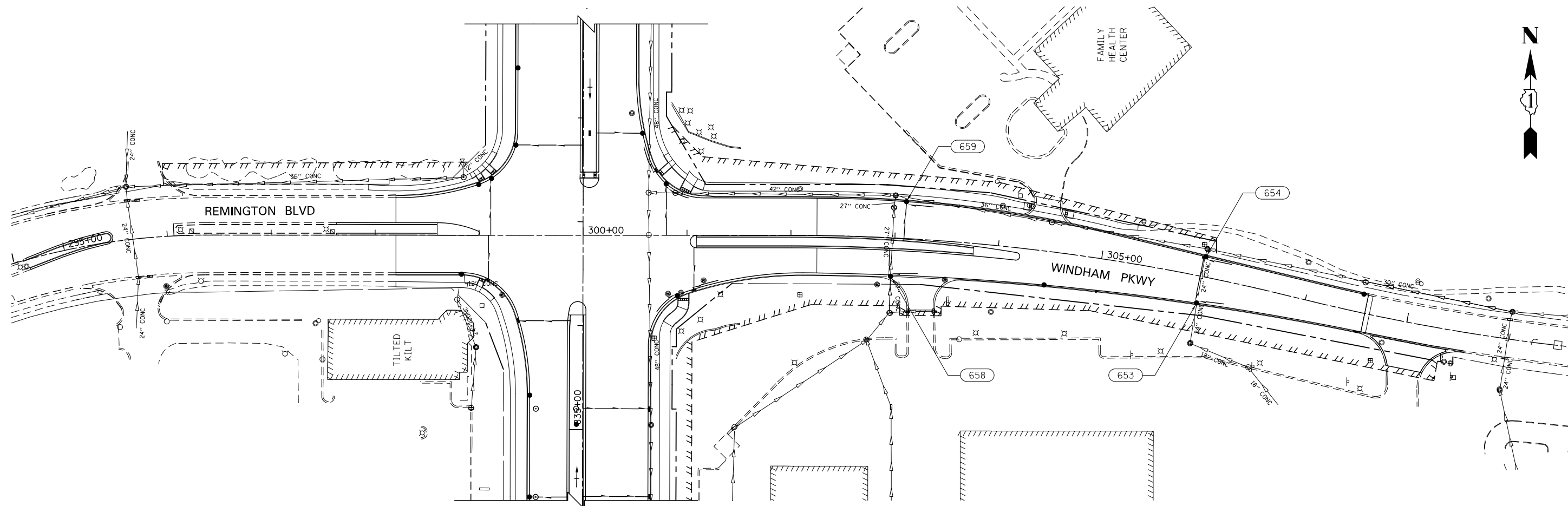

FOR CONTINUATION OF IMPROVEMENT
SEE WEBER RD PIPE UNDERDRAIN PLAN

STRUCTURE NUMBER	FROM		TO		PIPE UNDERDRAINS, TYPE 2, 4" (FOOT)	PIPE UNDERDRAINS 4" (SPECIAL) (FOOT)	
	STATION	OFFSET	STRUCTURE NUMBER	STATION			OFFSET
HIGH	303+10.0	2.5 RT	659	303+10.0	36.0 LT	37	
HIGH	303+35.0	35.0 LT	659	303+10.0	36.0 LT	25	
HIGH	302+98.0	9.9 RT	658	302+98.0	36.0 RT	25	
HIGH	303+23.0	35.3 RT	658	302+98.0	36.0 RT	25	
HIGH	305+98.0	0.0 LT	654	305+98.0	26.0 LT	17	
HIGH	306+23.0	18.6 LT	654	305+98.0	26.0 LT	24	
HIGH	305+98.0	0.0 LT	653	305+98.0	26.0 RT	24	
HIGH	306+23.0	24.6 RT	653	305+98.0	26.0 RT	24	
					SUBTOTAL	201 FT	0 FT

NOTE:

PIPE UNDERDRAINS, TYPE 2, 4" SHALL BE PLACED AT A DEPTH OF 30" BELOW THE TOP OF PROPOSED PAVEMENT OR AS DEEP AS POSSIBLE.

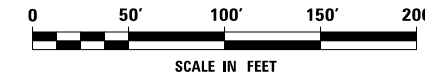
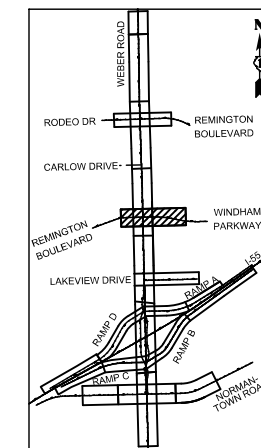

FILE NAME = D:\60X10-shr-drain\2-underdrain\2-Remington-Windham.dgn

KNIGHT Engineers & Architects	USER NAME = mmaestra	DESIGNED REM	REVISED -
	PLOT SCALE = 1:100	DRAWN DGB	REVISED -
	PLOT DATE = 5/13/2017	CHECKED PJO	REVISED -
		DATE 05/12/17	REVISED -

**STATE OF ILLINOIS
DEPARTMENT OF TRANSPORTATION**

**PIPE UNDERDRAIN PLAN
REMINGTON BOULEVARD / WINDHAM DRIVE**

SCALE: AS SHOWN | SHEET NO. 12 OF 22 SHEETS | STA. 296+06 TO STA. 307+59

F.A.I./P RTE.	SECTION	COUNTY	TOTAL SHEETS	SHEET NO.
*	(99-1HB-1) R-1	WILL	1508	598
CONTRACT NO. 60X10				
* FAI 55, FAP 856 ILLINOIS FED. AID PROJECT				

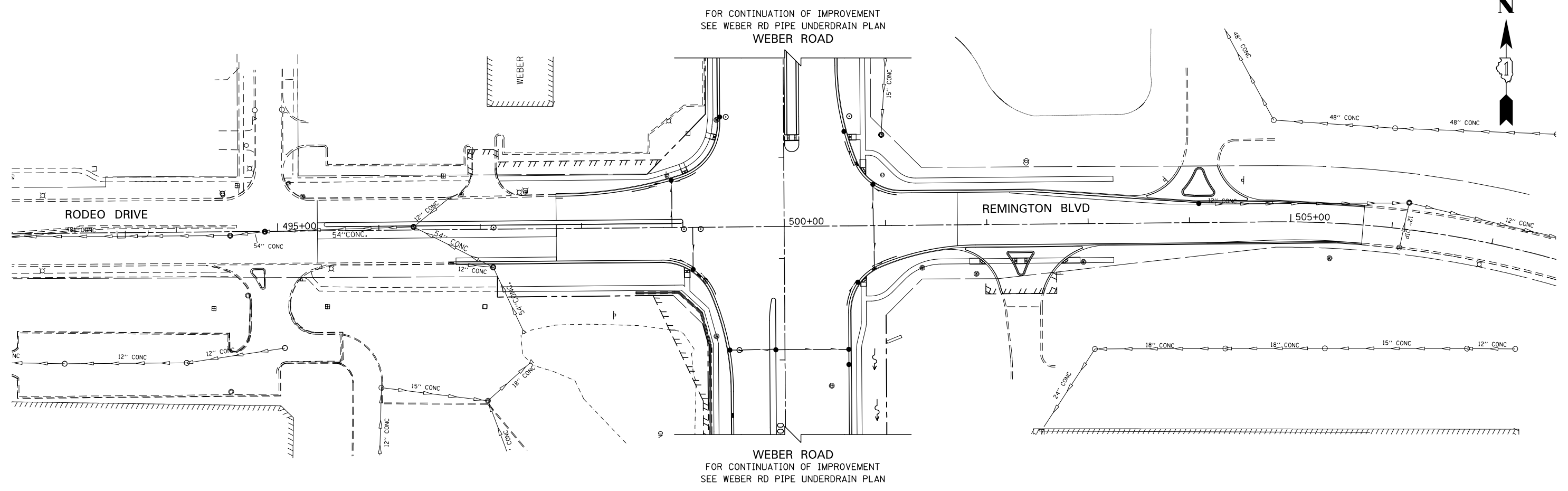
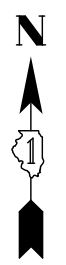

FOR CONTINUATION OF IMPROVEMENT
SEE WEBER RD PIPE UNDERDRAIN PLAN
WEBER ROAD

WEBER ROAD
FOR CONTINUATION OF IMPROVEMENT
SEE WEBER RD PIPE UNDERDRAIN PLAN

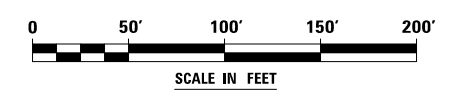
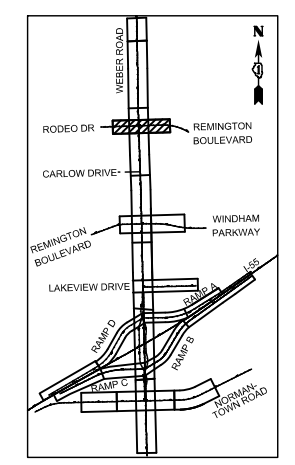

FILE NAME = D:\60X10-shr-drain\3-under-drain\3-RodeoRemington.dgn

KNIGHT
Engineers & Architects

USER NAME = mmaestra	DESIGNED REM	REVISED -
PLOT SCALE = 1:100	DRAWN DGB	REVISED -
PLOT DATE = 5/15/2017	CHECKED PJO	REVISED -
	DATE 05/12/17	REVISED -

**STATE OF ILLINOIS
DEPARTMENT OF TRANSPORTATION**

**PIPE UNDERDRAIN PLAN
RODEO DRIVE / REMINGTON BOULEVARD**

SCALE: AS SHOWN SHEET NO. 13 OF 22 SHEETS STA. 459+39 TO STA. 505+72

F.A.I./P RTE.	SECTION	COUNTY	TOTAL SHEETS	SHEET NO.
*	(99-1HB-1) R-1	WILL	1508	599
CONTRACT NO. 60X10				
* FAI 55, FAP 856 [ILLINOIS] FED. AID PROJECT				

SEE RAMP B
PIPE UNDERDRAIN PLAN SHEETS

SEE RAMP B
PIPE UNDERDRAIN PLAN SHEETS

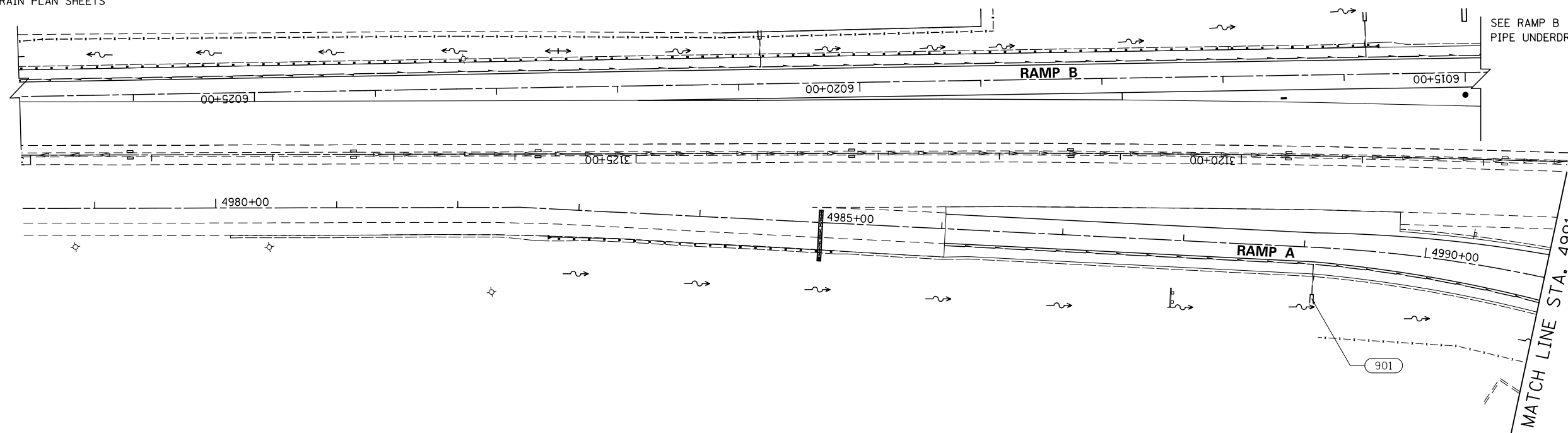

STRUCTURE NUMBER	FROM		TO		PIPE UNDERDRAINS, TYPE 2, 4" (FOOT)	PIPE UNDERDRAINS (SPECIAL) 4" (FOOT)
	STATION	OFFSET	STRUCTURE NUMBER	STATION		
HIGH	4986+03.0	14.0 RT	OUTLET	4989+08.0	14.0 RT	305
OUTLET	4989+08.0	14.0 RT	901	4989+08.0	39.0 RT	25
HIGH	4989+09.9	14.0 RT	OUTLET	4993+54.0	24.0 RT	436
					SUBTOTAL	741 FT

NOTE:

PIPE UNDERDRAINS, TYPE 2, 4" SHALL BE PLACED AT A DEPTH OF 30" BELOW THE TOP OF PROPOSED PAVEMENT OR AS DEEP AS POSSIBLE.

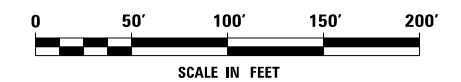
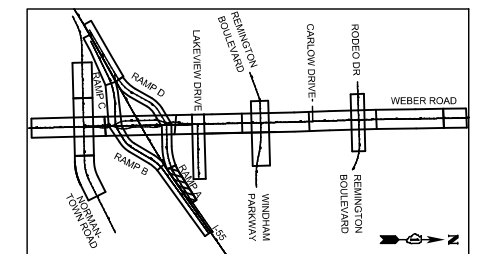

FILE NAME = D:\60X10-shr-drain\4-underdrain-14-155 RampA.dgn

KNIGHT
Engineers & Architects

USER NAME = mmaestra	DESIGNED REM	REVISED -
DRAWN DGB	DRAWN DGB	REVISED -
PLOT SCALE = 1:100	CHECKED PJO	REVISED -
PLOT DATE = 5/13/2017	DATE 05/12/17	REVISED -

STATE OF ILLINOIS
DEPARTMENT OF TRANSPORTATION

PIPE UNDERDRAIN PLAN - RAMP A

SCALE: AS SHOWN | SHEET NO. 14 OF 22 SHEETS | STA. 4982+75 TO STA. 4991+00

F.A.I./P RTE.	SECTION	COUNTY	TOTAL SHEETS	SHEET NO.
*	(99-1HB-1) R-1	WILL	1508	600
CONTRACT NO. 60X10			* FAI 55, FAP 856 [ILLINOIS] FED. AID PROJECT	