

-INDEX TO SHEETS-

- 1 COVER SHEET
- 2 GENERAL NOTES\TYPICAL SECTIONS
- 3 DETAILS
- 4 PLAN & PROFILE
- 5-6 STAGE CONSTRUCTION
- 7 TRAFFIC CONTROL
- 8-16 BRIDGE PLANS
- 17-18 CROSS SECTIONS

STATE OF ILLINOIS
DEPARTMENT OF TRANSPORTATION
PLANS FOR PROPOSED
LOCAL AGENCY IMPROVEMENT
FEDERAL AID B.R.R.P. PROJECT
FAS 840 DOUGLAS-FREEBURG ROAD (C.H. 47)
PROJECT NO. ABRS-840(102)
SECTION 00-00196-08-BR
ST. CLAIR COUNTY
JOB NO C-98-340-04

SECTION NO.	COUNTY HIGHWAY	COUNTY	SHEET OF SHEETS
00-00196-08-BR	47	ST. CLAIR	1 OF 18
FHWA REG. NO. 7 ILLINOIS		FEDERAL AID PROJECT	
CONTRACT 97257			

SUMMARY OF QUANTITIES

CODE NO.	ITEM	UNIT	QUANTITY
20200100	EARTH EXCAVATION	CU YD	62
20300100	CHANNEL EXCAVATION	CU YD	614
25000200	SEEDING, CLASS 2	ACRE	0.2
25000400	NITROGEN FERTILIZER NUTRIENT	POUND	18
25000500	PHOSPHORUS FERTILIZER NUTRIENT	POUND	18
25000600	POTASSIUM FERTILIZER NUTRIENT	POUND	18
25100630	EROSION CONTROL BLANKET	SQ YD	877
* 28000250	TEMPORARY EROSION CONTROL SEEDING	POUND	20
28000400	PERIMETER EROSION BARRIER	FOOT	475
28100713	STONE DUMPED RIPRAP, CLASS A7	SQ YD	650
28200200	FILTER FABRIC	SQ YD	650
35100700	AGGREGATE BASE COURSE, TYPE A 8"	SQ YD	103
42001165	BRIDGE APPROACH PAVEMENT	SQ YD	240
44000100	PAVEMENT REMOVAL	SQ YD	229
48202800	BITUMINOUS SHOULDERS SUPERPAVE 10"	SQ YD	157
50100100	REMOVAL OF EXISTING STRUCTURES	EACH	1
50300225	CONCRETE STRUCTURES	CU YD	58.6
50400505	PRECAST PRESTRESSED CONCRETE DECK BEAMS (27" DEPTH)	SQ FT	5031
50800205	REINFORCEMENT BARS, EPOXY COATED	POUND	4810
50901005	STEEL BRIDGE RAIL, TYPE SM	FOOT	280
51201600	FURNISHING STEEL PILES HP12x53	FOOT	2999
51202700	DRIVING STEEL PILES	FOOT	2999
51203600	TEST PILE STEEL HP12x53	EACH	2
51204315	CONCRETE ENCASEMENT	CU YD	48.4
51204600	METAL SHOES	EACH	28
* 51205200	TEMPORARY SHEET PILING	SQ FT	706
51500100	NAME PLATES	EACH	1
58100200	WATERPROOFING MEMBRANE SYSTEM	SQ YD	560
58300100	PORTLAND CEMENT MORTAR FAIRING COURSE	FOOT	1120
63100087	TRAFFIC BARRIER TERMINAL, TYPE 6A	EACH	4
* 63100167	TRAFFIC BARRIER TERMINAL, TYPE 1, SPECIAL (TANGENT)	EACH	4
66700205	PERMANENT SURVEY MARKERS, TYPE I	EACH	2
67000400	ENGINEER'S FIELD OFFICE, TYPE A	CAL MO	4
* 67100100	MOBILIZATION	L SUM	1
* 70100405	TRAFFIC CONTROL AND PROTECTION, STANDARD 701321	EACH	1
* 70106500	TEMPORARY BRIDGE TRAFFIC SIGNALS	EACH	1
* 70106700	TEMPORARY RUMBLE STRIP	EACH	6
70300220	TEMPORARY PAVEMENT MARKING - LINE 4"	FOOT	225
70400100	TEMPORARY CONCRETE BARRIER	FOOT	515
70400200	RELOCATE TEMPORARY CONCRETE BARRIER	FOOT	402
70500615	TEMPORARY TRAFFIC BARRIER TERMINAL TYPE 1	EACH	2
70500675	TEMPORARY TRAFFIC BARRIER TERMINAL TYPE 8	EACH	2
Δ 78001110	PAINT PAVEMENT MARKING - LINE 4"	FOOT	705
78200100	MONODIRECTIONAL PRISMATIC BARRIER REFLECTOR	EACH	8
78201000	TERMINAL MARKING - DIRECT APPLIED	EACH	4
78300100	PAVEMENT MARKING REMOVAL	SQ FT	55
* X0974300	SIGN REMOVAL	EACH	12
X4066414	BITUMINOUS CONCRETE SURFACE COURSE, SUPERPAVE, MIX "C", N50	TON	94
X4073081	BITUMINOUS CONCRETE PAVEMENT (FULL DEPTH) (SUPERPAVE) 10"	SQ YD	103
* Z0002600	BAR SPLICERS	EACH	48
* Z0030250	IMPACT ATTENUATORS, TEMPORARY (NON-REDIRECTIVE), TEST LEVEL 3	EACH	2
* Z0030350	IMPACT ATTENUATORS, RELOCATE (NON-REDIRECTIVE), TEST LEVEL 3	EACH	2

*: SPECIAL PROVISIONS
Δ: SPECIALTY ITEM
Call Joint Utility Locating Information for Excavators (J.U.L.I.E.) before digging 800-892-0123

SMITHTON TOWNSHIP T.1S., R.8W.
S.W. CORNER SECTION 23

CONTRACT NO. 97257

X081-2A
FAS 840 DOUGLAS-FREEBURG ROAD (C.H. 47)
PROJECT NO. ABRS-840(102)
SECTION 00-00196-08-BR
ST. CLAIR COUNTY
JOB NO C-98-340-04

PLAN PROFILE 1:40
HORIZ 1:40
VERT 1:40
CROSS SECTIONS
HORIZ 1:10
VERT 1:10

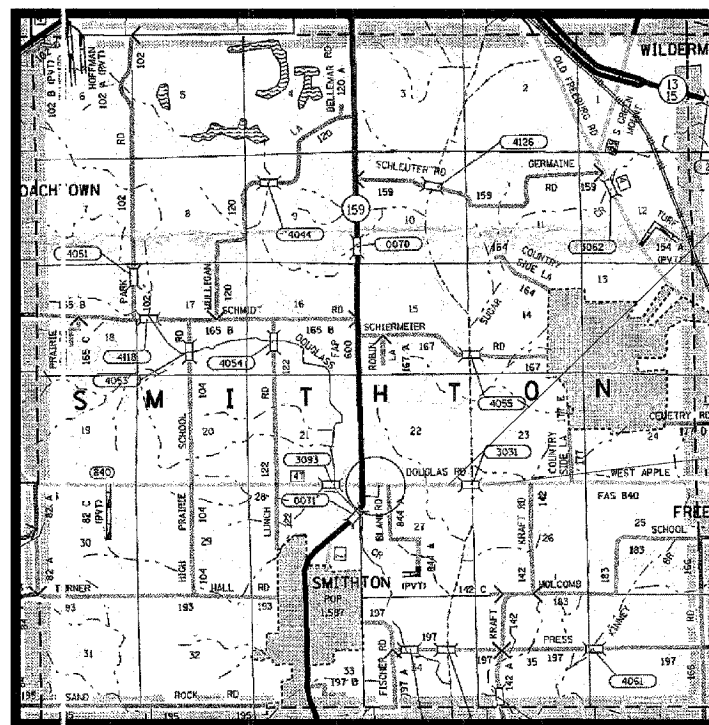

LOCATION MAP

STANDARDS

000001-04	631026-02
280001-02	635006-02
420401-05	667101
515001-02	701321-08
630001-05	702001-05
630301-03	704001-02
BLR 23-1	780001-01

LENGTH OF STRUCTURE = 141.50 ft (0.027 mi)
LENGTH OF ROADWAY = 98.50 ft (0.019 mi)
TOTAL LENGTH OF PROJECT = 240.00 ft (0.045 mi)

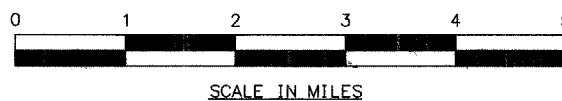

SECTION 00-00196-08-BR
BEGINS STATION 50+65.78

SECTION 00-00196-08-BR INCLUDES REMOVING AN EXISTING THREE (44'-56'-44") SPAN, 25' WIDE CAST-IN-PLACE DECK BRIDGE AND CONSTRUCTING A THREE (40'-60'-40") SPAN, 36' WIDE PRECAST, PRESTRESSED CONCRETE DECK BRIDGE AT STA. 51+85.80.

SECTION 00-00196-08-BR
ENDS STATION 53+05.78

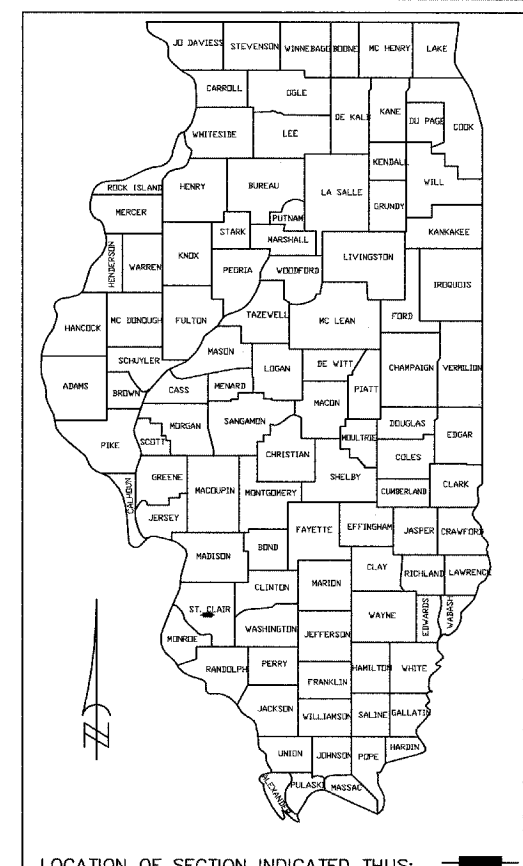

These plans were prepared by me or by a full-time member of my staff working under my personal supervision.

August 26, 2005

Darrell I. Cates

DARRELL I. CATES, P.E.
County Engineer
License Number 62-042908
License Expiration Date: November 30, 2005

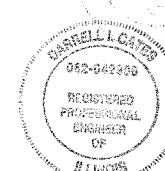

STATE OF ILLINOIS
DEPARTMENT OF TRANSPORTATION
DIVISION OF HIGHWAYS

APPROVED *Darrell Cates*, 2005
LOCAL AGENCY OFFICIAL

PASSED 9-14, 2005
Jennifer Obertus
DISTRICT ENGINEER OF
LOCAL ROADS & STREETS

APPROVED 9-14, 2005
Mary C. Lamie
MARY C. LAMIE, P.E.
DEPUTY DIRECTOR OF HIGHWAYS
REGION FIVE ENGINEER

GENERAL NOTES

- ALL MATERIALS DEEMED SALVAGEABLE BY THE ENGINEER SHALL REMAIN THE PROPERTY OF THE COUNTY HIGHWAY DEPARTMENT. ALL OTHER MATERIALS SHALL BE DISPOSED OF BY THE CONTRACTOR, AT HIS OWN EXPENSE.
- THE FOLLOWING ITEMS AND ESTIMATED QUANTITIES SHALL BE USED THROUGHOUT THIS PROJECT:
0.2 ACRE, SEEDING CLASS 2; 18 POUND, NITROGEN FERTILIZER NUTRIENT; 18 POUND PHOSPHOROUS FERTILIZER NUTRIENT; 18 POUND, POTASSIUM FERTILIZER NUTRIENT; 877 SQ YD, EROSION CONTROL BLANKET; 20 POUND, TEMPORARY EROSION CONTROL SEEDING.
- THE FOLLOWING UTILITY COMPANIES MAY HAVE FACILITIES LOCATED WITHIN THE LIMITS OF CONSTRUCTION.

MONROE COUNTY ELECTRIC CO-OP 6132 STATE RTE 3, PO BOX 128 WATERLOO, ILLINOIS 62298 (618) 939-7171	MEDIACOM 2250 NORTH ILLINOIS AVE CARBONDALE, ILLINOIS 62901 (618) 529-5749	SBC MIDWEST 203 GOETHE ST. COLLINSVILLE, ILLINOIS 62234 1-800-244-4444
--	---	---
- THE FOLLOWING FACTORS WERE USED TO DETERMINE THE REQUIRED AMOUNT OF MATERIALS NEEDED.

BITUMINOUS CONCRETE SURFACE COURSE	112 LBS/SQ YD/IN THK
------------------------------------	----------------------
- THE CONTRACTOR SHALL NOT BE ALLOWED TO SET THE DECK BEAMS UNTIL THE STEEL RAILING HAS BEEN DELIVERED TO THE JOB SITE OR TO THE CONTRACTORS YARD. PROOF OF SUCH DELIVERY MUST BE PRESENTED TO THE ENGINEER, AT HIS REQUEST, PRIOR TO THE PLACEMENT OF THE BEAMS.

SECTION NO.	COUNTY HIGHWAY	COUNTY	SHEET OF SHEETS
00-00196-08-BR.	47	ST. CLAIR	20F18
FHWA REG. NO. 7	ILLINOIS	FEDERAL AID PROJECT	
CONTRACT 97257			

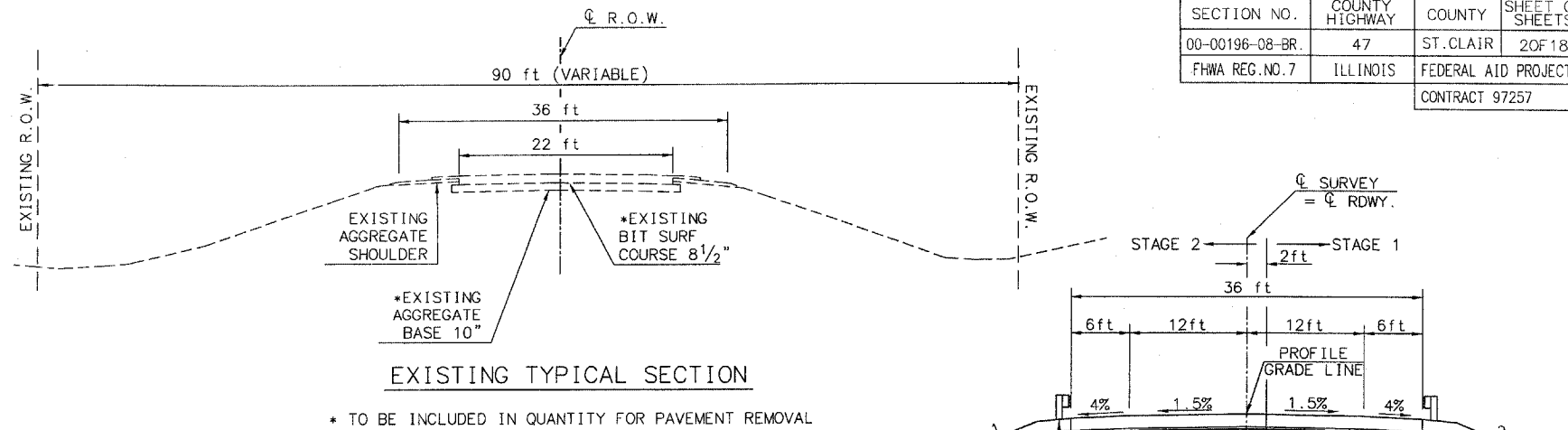

* TO BE INCLUDED IN QUANTITY FOR PAVEMENT REMOVAL

EARTHWORK SCHEDULE

LOCATION	EARTH EXCAVATION/ CHANNEL EXCAVATION	ECAVATION TO BE USED IN EMBANKMENT ADJUSTED FOR SHRINKAGE 25%	EMBANKMENT	EARTHWORK BALANCE (+) OR SHORTAGE (-)
	CU YDS	CU YDS	CU YDS	CU YDS
STA 50+00 TO STA 50+50	0.0	0.0	38.3	-38.3
STA 50+50 TO STA 50+65.78	0.0	0.0	23.9	-62.2
STA 50+65.78 TO STA 51+00	15.4	11.6	60.5	-111.1
STA 51+00 TO STA 51+15.04	6.8	5.1	98.2	-204.2
CHANNEL	613.8	460.4	0.0	+256.2
STA 52+56.54 TO STA 53+00	39.1	29.3	24.6	+260.9
STA 53+00 TO STA 53+05.79	0.8	0.6	3.5	+258.0
STA 53+05.79 TO STA 53+50	0.0	0.0	12.5	+245.5
TOTAL	675.9	507.0	261.5	+245.5

BITUMINOUS SHOULDERS SUPERPAVE 10" SCHEDULE

LOCATION	WIDTH	QUANTITY (SQYD)
STA. 50+02.03 - STA. 50+58.60 R	2.5' TO 7'	29.9
STA. 50+58.60 - STA. 50+65.78 R	7'	5.6
STA. 50+65.78 - STA. 50+85.83 R & LT	7' TO 6'	29.0
STA. 52+85.75 - STA. 53+05.78 R & LT	6' TO 7'	28.9
STA. 53+05.78 - STA. 53+11.49 R	7'	4.4
STA. 53+11.49 - STA. 53+66.82 R	7' TO 2.5'	29.2
TOTAL		157

BITUMINOUS CONCRETE PAVEMENT (FULL DEPTH) SUPERPAVE 10" SCHEDULE

LOCATION	WIDTH	QUANTITY (SQYD)
STA. 50+65.78 - STA. 50+85.83	22' TO 24'	51.2
STA. 52+85.75 - STA. 53+05.78	24' TO 22'	51.2
TOTAL		103

SIGN REMOVAL SCHEDULE

LOCATION	QUANTITY (EACH)
STA. 50+07.96 - 15.81' LT	1
STA. 50+15.26 - 18.01' RT	1
STA. 50+55.18 - 18.14' RT	1
STA. 50+56.32 - 14.09' LT	1
STA. 51+03.27 - 12.93' RT	1
STA. 51+03.42 - 13.25' LT	1
STA. 52+52.25 - 13.79' LT	1
STA. 52+52.54 - 13.32' RT	1
STA. 52+98.47 - 17.43' RT	1
STA. 53+00.42 - 17.72' LT	1
STA. 53+48.11 - 18.23' RT	1
STA. 53+50.44 - 17.52' LT	1
TOTAL	12

CENTERLINE TIES

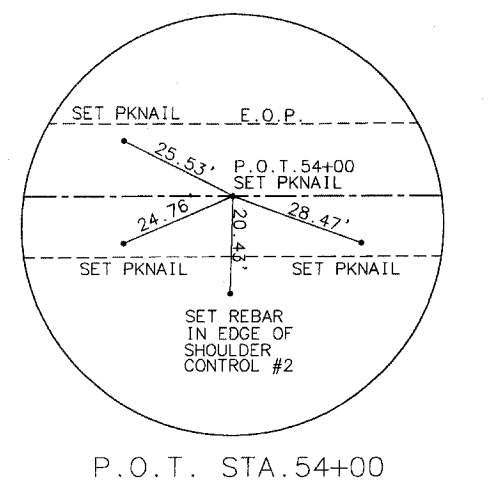
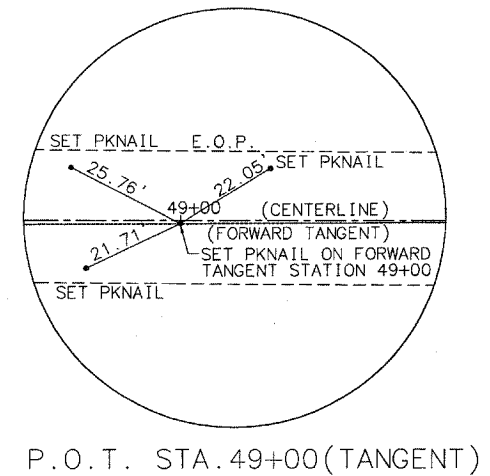

PROPOSED TYPICAL SECTION

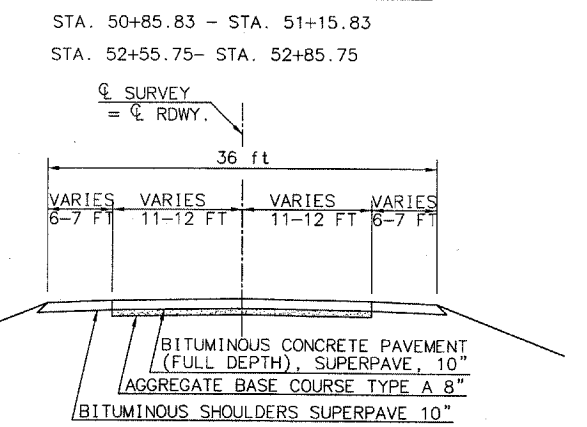

PROPOSED TYPICAL SECTION

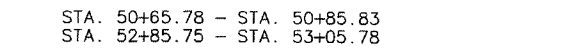

- NOTES**
- WARP FROM THE EXISTING SECTION TO THE PROPOSED TEMPLATE STA. 50+65.78 - STA. 50+85.83
 - WARP FROM THE PROPOSED SECTION TO THE EXISTING TEMPLATE STA. 52+85.75 - STA. 53+05.78

PAINT PAVEMENT MARKING LINE SCHEDULE

LOCATION	TYPE	COLOR	WIDTH	QUANTITY (FOOT)
STA. 50+65.78 - STA. 53+05.78 LT	EDGE LINE	WHITE	4 IN	240
STA. 50+65.78 - STA. 53+05.78 RT	EDGE LINE	WHITE	4 IN	240
STA. 47+45.50 - STA. 56+44.60 CL	CENTERLINE (DASHED)	YELLOW	4 IN	225
TOTAL				705

PAVEMENT MARKING REMOVAL SCHEDULE

LOCATION	TYPE	COLOR	WIDTH	QUANTITY (SOFT)
STA. 47+45.50 - STA. 50+65.78	CENTER LINE	YELLOW	4 IN	26.7
STA. 53+05.78 - STA. 56+44.60	CENTER LINE	YELLOW	4 IN	28.2
TOTAL				55

	INITIALS	DATE
DESIGNED	JLH	8/04
CHECKED	-	-
DRAWN	JLH	9/04
CHECKED	-	-
PREPARED BY ST. CLAIR COUNTY		
CADD DRAWING FILE: GENTYP		

FLEXIBLE PAVEMENT STRUCTURAL DESIGN INFORMATION

AVERAGE ESTIMATED ADT UPON COMPLETION (2005) = 3556
ROADWAY CLASSIFICATION - CLASS II

PROPOSED MATERIALS:
AGGREGATE BASE COURSE, TYPE A, 8 IN
BITUMINOUS CONCRETE PAVEMENT (FULL DEPTH) SUPERPAVE 10"

SECTION NO.	COUNTY HIGHWAY	COUNTY	SHEET OF SHEETS
00-00196-08-BR.	47	ST. CLAIR	3 OF 18
FHWA REG. NO. 7	ILLINOIS	FEDERAL AID PROJECT	
CONTRACT 97257			

BAR SPLICER ASSEMBLY DETAILS

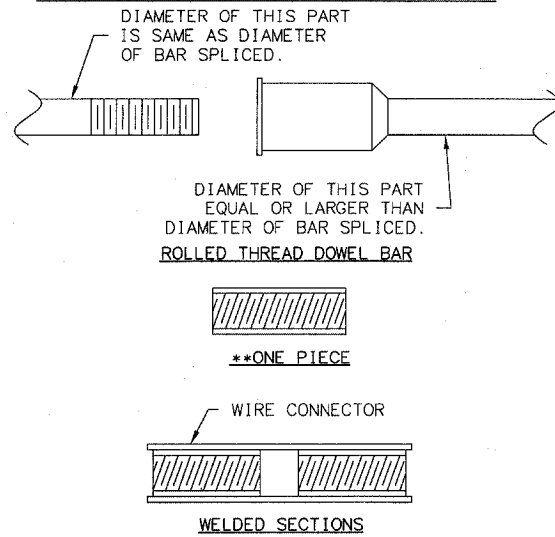

BAR SPLICER ASSEMBLY ALTERNATIVES

** HEAVY HEX NUTS CONFORMING TO ASTM A 563, GRADE C, D OR DH MAY BE USED.

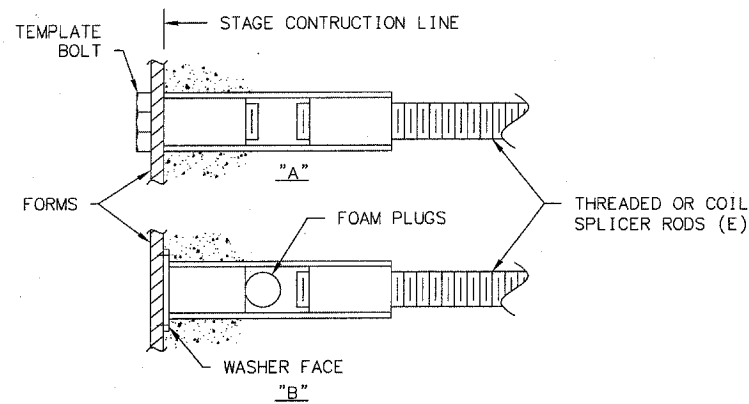

INSTALLATION AND SETTING METHODS

"A" : SET BAR SPLICER ASSEMBLY BY MEANS OF A TEMPLATE BOLT.

"B" : SET BAR SPLICER ASSEMBLY BY NAILING TO WOOD FORMS OR CEMENTING TO STEEL FORMS.

(E) : INDICATES EPOXY COATING.

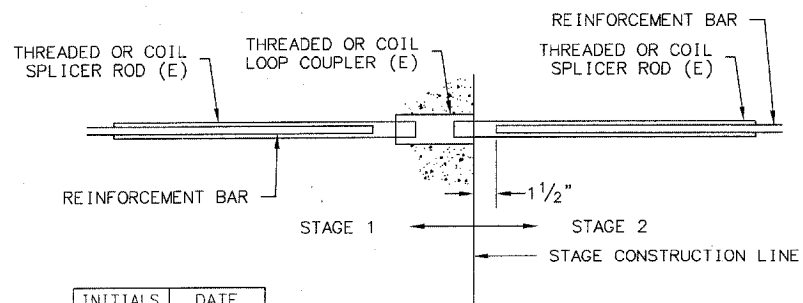

	INITIALS	DATE
DESIGNED	JLH	2/05
CHECKED	-	-
DRAWN	JLH	2/05
CHECKED	-	-
PREPARED BY ST. CLAIR COUNTY		
CADD DRAWING FILE: DETAILS		

TEMPORARY SHEET PILING DETAIL

WEST PILING

AREA = 394 SQ FT
REQUIRED SECTION MODULUS = 3.3 CU IN/FT

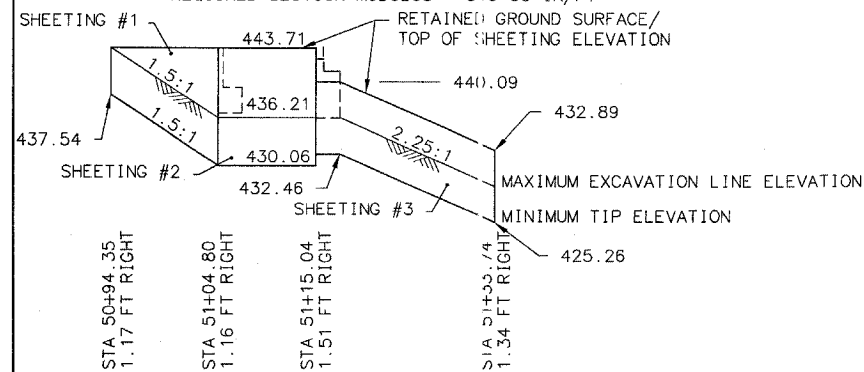

EAST PILING

AREA = 312 SQ FT
REQUIRED SECTION MODULUS = 8.57 CU IN/FT

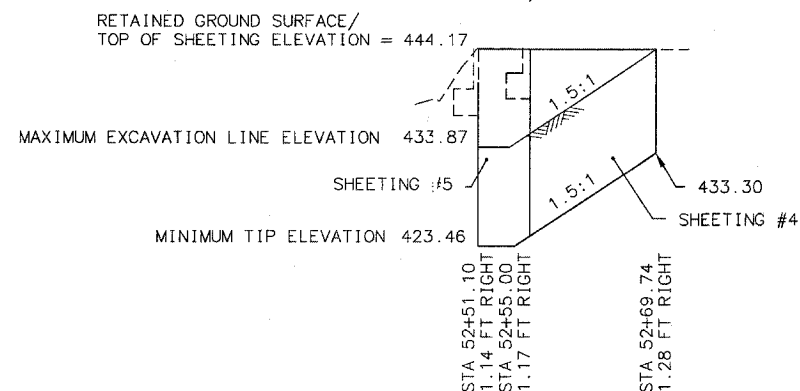

NOTES:

IF THE CONTRACTOR CHOOSES TO ALTER THE TEMPORARY CANTILEVER SHEET PILING DESIGN REQUIREMENTS SHOWN ON THE PLANS, A DESIGN SUBMITTAL INCLUDING PLAN DETAILS AND CALCULATIONS WILL BE REQUIRED FOR REVIEW AND ACCEPTANCE BY THE ENGINEER.

SHEET PILING SHALL BE UTILIZED IN SECTIONS TO COINCIDE WITH STAGE CONSTRUCTION.

NOTES:

BAR SPLICER ASSEMBLIES SHALL BE OF AN APPROVED TYPE AND DEVELOPE IN TENSION AT LEAST 125 PERCENT OF THE YIELD STRENGTH OF THE LAPPED REINFORCEMENT BARS. SPLICER RODS SHALL BE OF MINIMUM 60 ksi YIELD STRENGTH, THREADED OR COILED FULL LENGTH. ALL REINFORCEMENT BARS SHALL BE LAPPED AND TIED TO THE SPLICER RODS OR DOWEL BARS. BAR SPLICER ASSEMBLIES SHALL BE EPOXY COATED ACCORDING TO THE REQUIREMENTS FOR REINFORCEMENT BARS.

OTHER SYSTEMS OF SIMILAR DESIGN MAY BE SUBMITTED TO THE ENGINEER FOR APPROVAL. APPROVAL SHALL BE BASED ON CERTIFIED TEST RESULTS FROM AN APPROVED TESTING LABORATORY THAT THE PROPOSED BAR SPLICER ASSEMBLY SATISFIES THE FOLLOWING REQUIREMENTS:

- 1 MINIMUM CAPACITY (TENSION IN KIPS) = $1.25 \times f_y \times A_1$
- 2 MINIMUM *PULL-OUT STRENGTH (TENSION IN KIPS) = $1.25 \times f_s \text{ allow} \times A_1$

WHERE f_y = ALLOWABLE TENSILE STRESS IN LAPPED REINFORCEMENT BARS IN ksi.
 $f_s \text{ allow}$ = ALLOWABLE TENSILE STRESS IN LAPPED REINFORCEMENT BARS IN ksi (SERVICE LOAD)
 A_1 = TENSILE STRESS AREA OF LAPPED REINFORCEMENT BARS.
* = 28 DAY CONCRETE

BAR SPLICER ASSEMBLY			
BAR SIZE TO BE SPLICED	SPLICER ROD OR DOWEL BAR LENGTH	STRENGTH REQUIREMENTS	
		MIN CAPACITY kips-TENSION	MIN PULL-OUT STRENGTH kips-TENSION
#4	1'-8"	14.7	5.9
#5	2'-0"	23.0	9.2
#7	3'-5"	45.1	18.0

BAR SPLICER ASSEMBLIES SHALL BE ACCORDING TO SECTION 508 OF THE STANDARD SPECIFICATIONS, EXCEPT AS NOTED.

SHEAR KEY CLAMPING DETAIL AT STAGE CONSTRUCTION JOINT

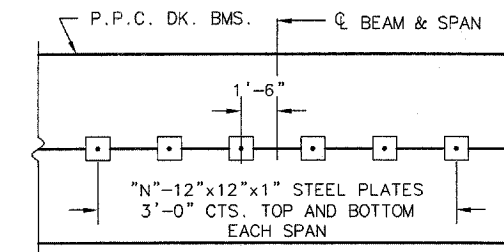

PLAN

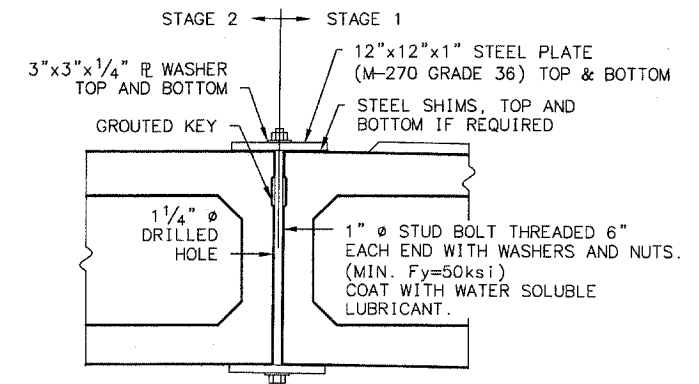

SECTION

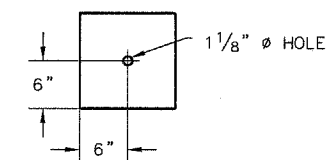

CLAMPING PLATE

NOTES:

1. SEE SPECIAL PROVISIONS FOR STAGE CONSTRUCTION OF PRECAST PRESTRESSED CONCRETE DECK BEAMS.
2. SEE SHEETS 5 & 6 FOR STAGE CONSTRUCTION DETAILS.
3. COST OF SHEAR KEY CLAMPS ARE INCLUDED IN PRECAST PRESTRESSED CONCRETE DECK BEAMS.

N=6 FOR SPANS UP TO 48 FT.
N=8 FOR SPANS UP TO 64 FT.

CURVE INFORMATION
 P.I. STA. 48+27.8
 $\Delta = 0^\circ-50'$
 $D = 0^\circ-08'$
 $R = 42971.84'$
 $T = 312.8'$
 $L = 625.1'$

DONALD BIEHL FARMS
 13-22.0-400-004
 5420 SCHMID LANE
 BELLEVILLE, IL 62220
 119.94 ACRE

STA. 51+85.80
 PROPOSED THREE SPAN (40'-60'-40') PRECAST
 PRESTRESSED CONCRETE DECK BEAMS ON REINFORCED
 CONCRETE CAPS WITH HP 12x53 STEEL PILES. 0' SKEW,
 141.50' BK-BK ABUTS ALONG Q STRUCTURE. SEE S'AGE
 CONSTRUCTION SHEET.

LARRY M. & BEVERLY EITZENHEFER
 13-23.0-300-008
 2 NORTH WEST STREET
 FREEBURG, IL 62243
 15.52 ACRE

SECTION NO.	COUNTY HIGHWAY	COUNTY	SHEET OF SHEETS
00-00196-08-BR	47	ST. CLAIR	4 OF 18
FHWA REG. NO. X	ILLINOIS	FEDERAL AID PROJECT CONTRACT 97257	

BEGIN SECTION 00-00196-08-BR
 STA. 50+65.78

SEE TEMPORARY SHEET
 PILING DETAIL ON PAGE 3

END SECTION 00-00196-08-BR
 STA. 53+05.78

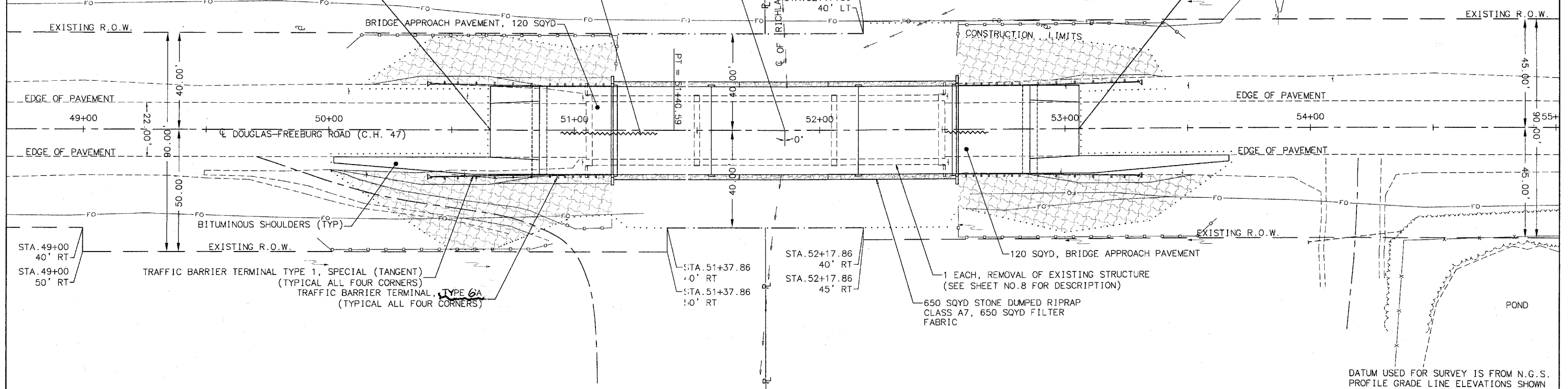

LEGEND

- x— TIMBER LINE
- x- FENCE LINE
- ⊕ POWER POLE
- FO- BURIED FIBER OPTIC LINE
- - - EXISTING CULVERT
- ⊕ EXISTING SIGN
- o— PERIMETER EROSION BARRIER
- x— TEMPORARY SHEET PILING
- x— EROSION CONTROL BLANKET

DONALD E. & MARYANN A. BIEHL
 13-27.0-200-003
 5420 SCHMID LANE
 BELLEVILLE, IL 62220
 19.28 ACRE

KRAFT LARRY TRUSTEE
 13-26.0-100-001
 4957 QUIRIN ROAD
 SMITHTON, IL 62285
 63.2 ACRE

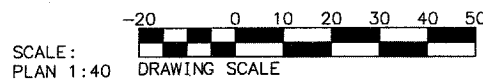

BENCHMARK: FOUND CHISELED SQUARE
 TOP OF S.W. WINGWALL ELEVATION = 443.52 FT.

PERIMETER EROSION BARRIER		
STA. 50+07.50 - STA. 51+17.50	LT	120 FT
STA. 49+95.40 - STA. 51+15.30	RT	127 FT
STA. 52+56.60 - STA. 53+49.10	LT	108 FT
STA. 52+56.50 - STA. 53+62.40	RT	120 FT
		TOTAL 475 FT

PERMANENT SURVEY MARKERS, TYPE 1,
 SHALL BE PLACED AT THE FOLLOWING
 LOCATIONS: STA 51+15.42
 STA 52+56.17

PAVEMENT REMOVAL		
STA. 50+65.78 - STA. 51+04.80		95.4 SQ YD
STA. 52+51.10 - STA. 53+05.78		133.7 SQ YD
TOTAL		229 SQ YD

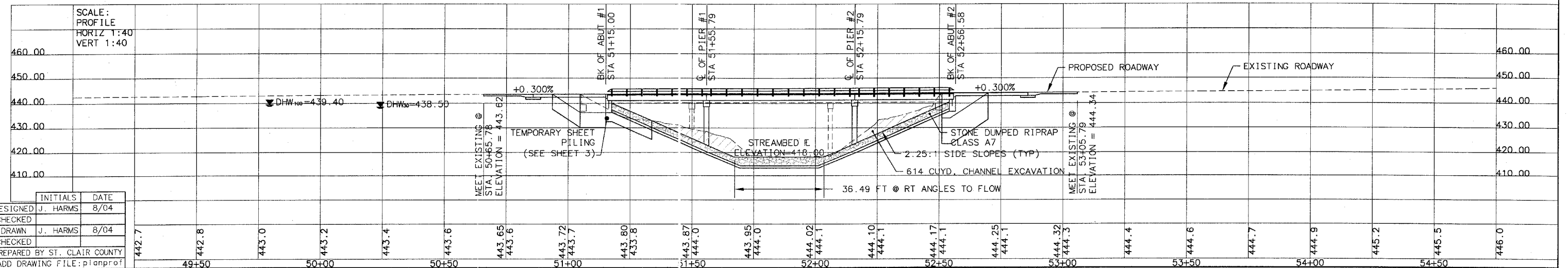

INITIALS	DATE
DESIGNED J. HARMS	8/04
CHECKED J. HARMS	8/04
DRAWN J. HARMS	8/04
CHECKED	
PREPARED BY ST. CLAIR COUNTY	
CADD DRAWING FILE: planprof	

SECTION NO.	COUNTY HIGHWAY	COUNTY	SHEET OF SHEETS
00-00196-08-BR	47	ST. CLAIR	5 OF 18
FHWA REG. NO. x	ILLINOIS	FEDERAL AID PROJECT	
STAGE CONSTRUCTION PLAN		CONTRACT 97257	

STAGE 1 NOTES

1. INSTALL TRAFFIC CONTROL ACCORDING TO STANDARD 701321.
2. SAW CUT AND REMOVE SOUTH PORTION OF EXISTING STRUCTURE.
3. DRIVE TEMPORARY SHEET PILING.
4. PERFORM DIRT WORK OPERATIONS.
5. SEED AND PLACE EROSION CONTROL BLANKET ON DISTURBED EARTH.
6. CONSTRUCT SOUTH PORTION OF PROPOSED STRUCTURE AND APPROACH PAVEMENT.
7. INSTALL BRIDGE RAIL AND APPROACH RAIL ON SOUTH SIDE OF ROADWAY.

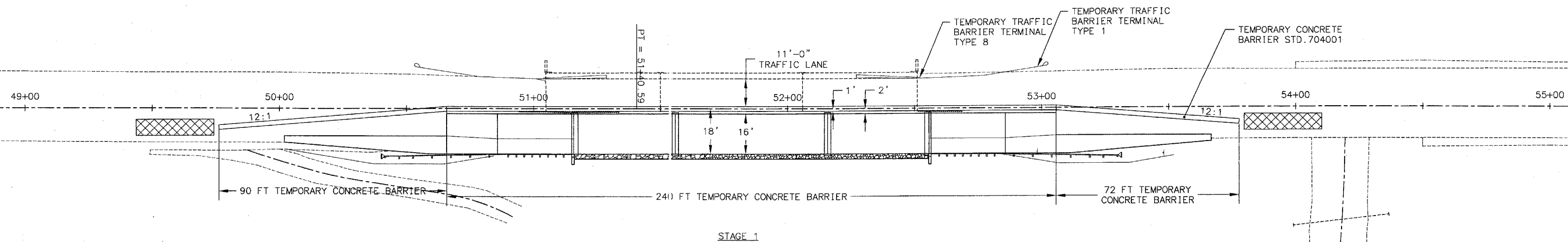

STAGE 1

STAGE 2 NOTES

1. RELOCATE TRAFFIC CONTROL ACCORDING TO STANDARD 701321.
2. REMOVE REMAINING PORTION OF EXISTING STRUCTURE.
3. PERFORM DIRT WORK OPERATIONS.
4. SEED AND PLACE EROSION CONTROL BLANKET ON DISTURBED EARTH.
5. REMOVE TEMPORARY SHEET PILING.
6. CONSTRUCT REMAINING PORTION OF PROPOSED STRUCTURE AND APPROACH PAVEMENT.
7. INSTALL BRIDGE RAIL AND APPROACH RAIL ON NORTH SIDE OF ROADWAY.
8. REMOVE TRAFFIC CONTROL ACCORDING TO STANDARD 701321.

LEGEND

 IMPACT ATTENUATOR, TEMPORARY (NON-REDIRECTIVE), TEST LEVEL 3

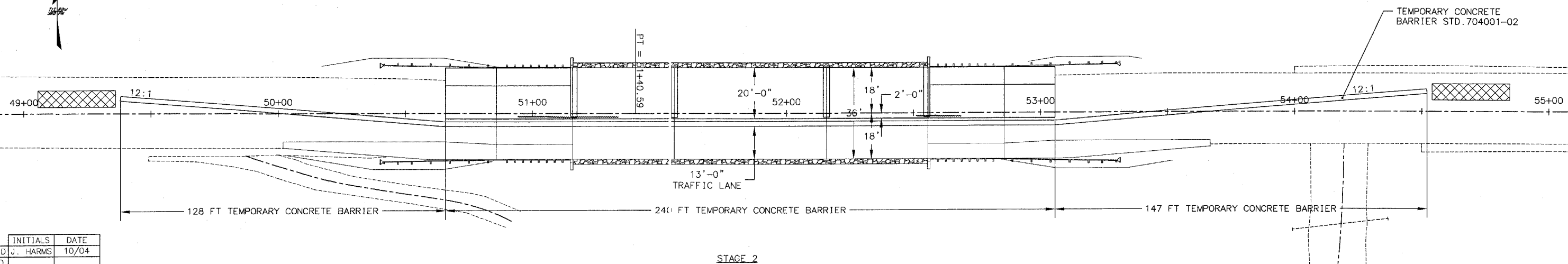

STAGE 2

	INITIALS	DATE
DESIGNED	J. HARMS	10/04
CHECKED		
DRAWN	J. HARMS	10/04
CHECKED		
PREPARED BY ST. CLAIR COUNTY		
CADD DRAWING FILE:stagecons		

PLOT DATE:

SECTION NO.	COUNTY HIGHWAY	COUNTY	SHEET OF SHEETS
00-00196-08-BR	47	ST. CLAIR	6 OF 18
FHWA REG. NO. x	ILLINOIS	FEDERAL AID PROJECT	
STAGE CONSTRUCTION SECTIONS		CONTRACT 97257	

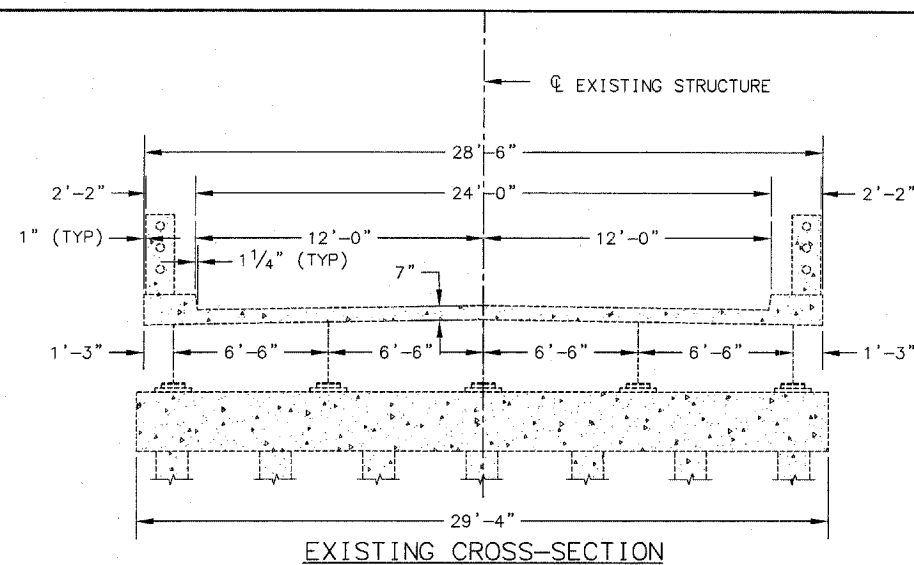

EXISTING CROSS-SECTION

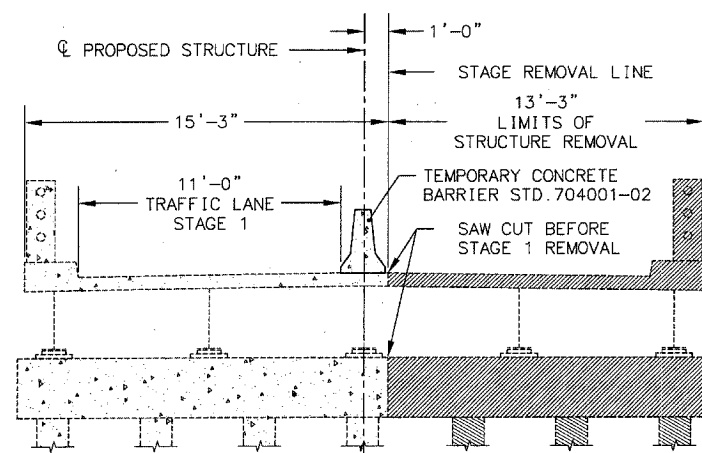

STAGE 1 REMOVAL
(LOOKING EAST)

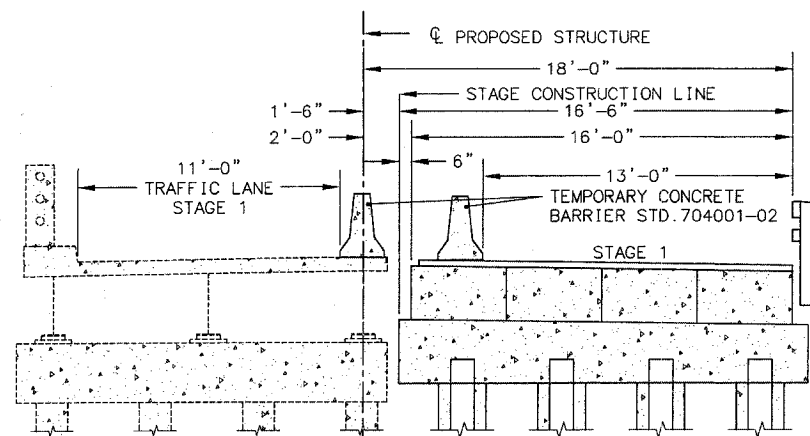

STAGE 1 CONSTRUCTION
(LOOKING EAST)

NOTES

1. THE APPLICATION OF FIBERGLASS FABRIC IN THE WATERPROOFING MEMBRANE SYSTEM SHALL BE CONSTRUCTED IN SUCH A MANNER AS TO ENSURE THE PROPER OVERLAPPING OF THE MATERIAL BETWEEN THE STAGE 1 AND STAGE 2 CONSTRUCTION.
2. THE CONTRACTOR SHALL CONSTRUCT A BONDED CONSTRUCTION JOINT WHEN JOINING PROPOSED STAGE 2 TO STAGE 1 AND BAR SPLICERS SHALL BE UTILIZED AS SHOWN IN PLANS.

LEGEND

■ REMOVAL

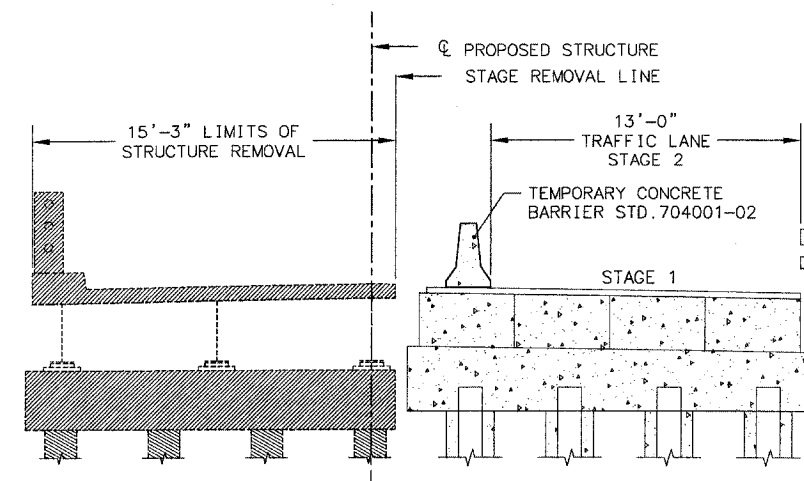

STAGE 2 REMOVAL
(LOOKING EAST)

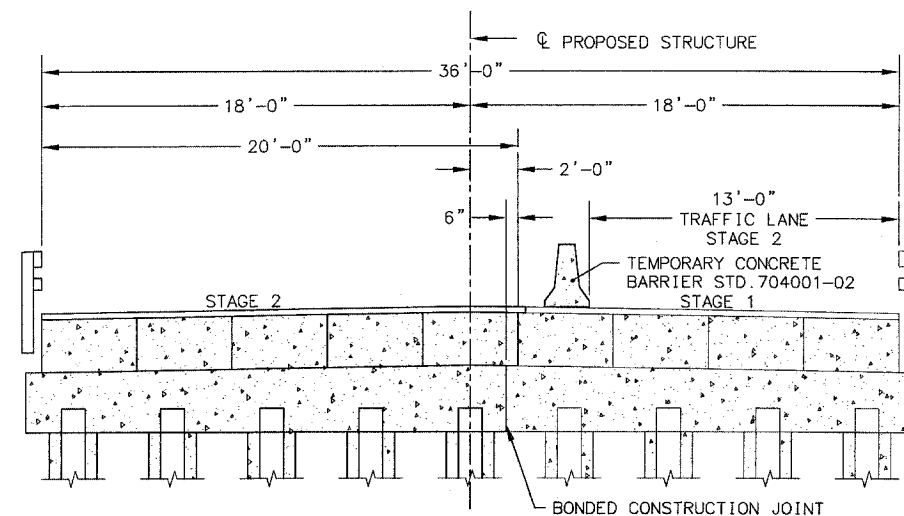

STAGE 2 CONSTRUCTION
(LOOKING EAST)

	INITIALS	DATE
DESIGNED	J. HARMS	10/04
CHECKED		
DRAWN	J. HARMS	10/04
CHECKED		
PREPARED BY ST. CLAIR COUNTY		
CADD DRAWING FILE:stagecons		

PLOT DATE:

SECTION NO.	COUNTY HIGHWAY	COUNTY	SHEET OF SHEETS
00-00196-08-BR.	47	ST. CLAIR	7 OF 18
FHWA REG. NO. 7	ILLINOIS	FEDERAL AID PROJECT	
CONTRACT 97257			

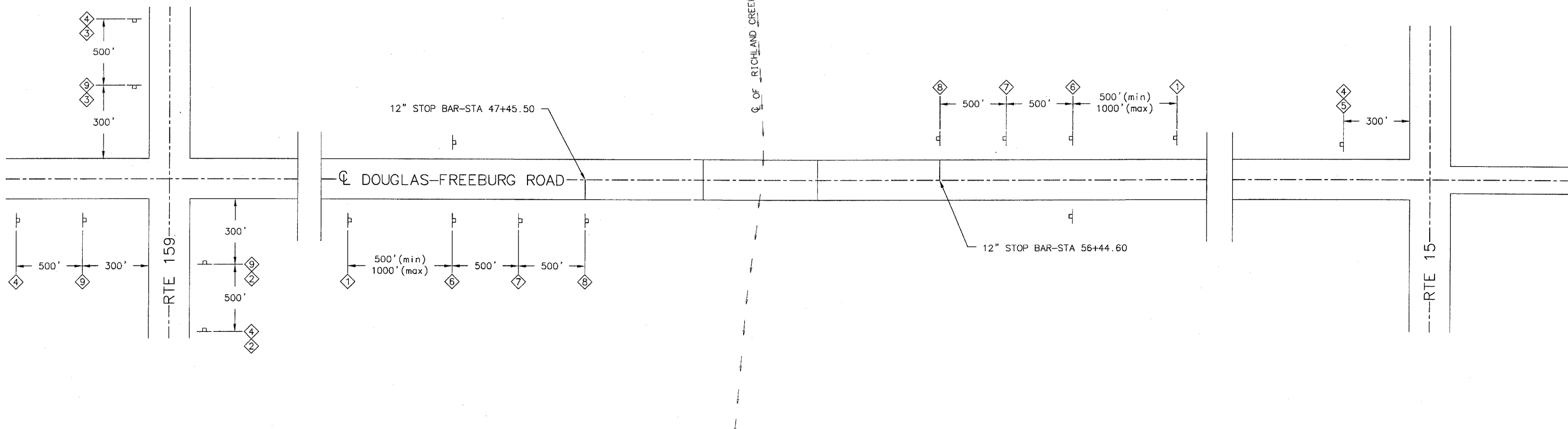

GENERAL NOTES

1. FOR ADDITIONAL TRAFFIC CONTROL DETAILS SEE STANDARD 701321-08.
2. THE ENGINEER MAY ADJUST TRAFFIC CONTROL TO FIT FIELD CONDITIONS.
3. LANE WIDTH RESTRICTION SIGNS WILL BE REQUIRED DURING STAGE 1 ONLY.
4. SEE STAGE CONSTRUCTION DETAILS FOR FURTHER INFORMATION.

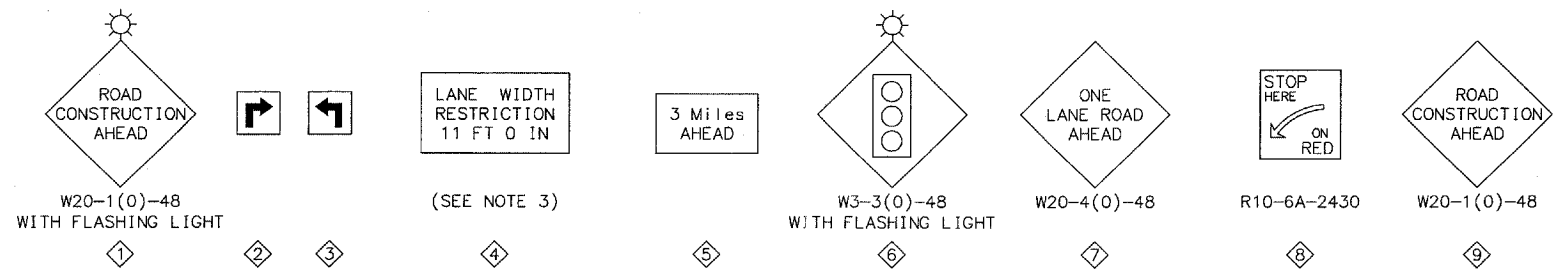

	INITIALS	DATE
DESIGNED	JLH	3/05
CHECKED	-	-
DRAWN	JLH	3/05
CHECKED	-	-
PREPARED BY ST. CLAIR COUNTY		
CADD DRAWING FILE: TRAF_CONT		

EXISTING STRUCTURE NO. 082-3031
 A THREE (44'-56'-44') SPAN BRIDGE WITH STEEL GIRDERS.
 CAST IN PLACE CONCRETE DECK, SPILL THROUGH ABUTMENT AND
 28.5 FT WIDE DECK (OUT-TO-OUT).

SALVAGE: ALL MATERIALS REQUIRED TO BE REMOVED WHICH ARE
 CONSIDERED SALVAGABLE BY THE ENGINEER SHALL REMAIN THE
 PROPERTY OF THE COUNTY. ALL OTHERS SHALL BE DISPOSED OF
 BY THE CONTRACTOR AT HIS OWN EXPENSE.

SECTION NO.	COUNTY HWY.	COUNTY	SHEET OF SHEETS
00-00196-08-BR	47	ST. CLAIR	8 OF 18
FHWA REG. NO. 7	ILLINOIS	FED. AID PROJECT	
CONTRACT 97257			

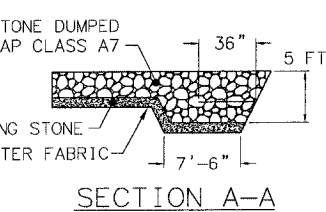
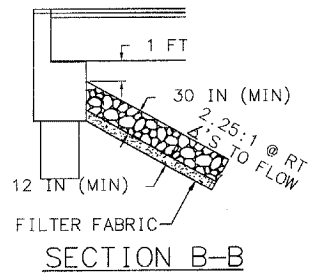
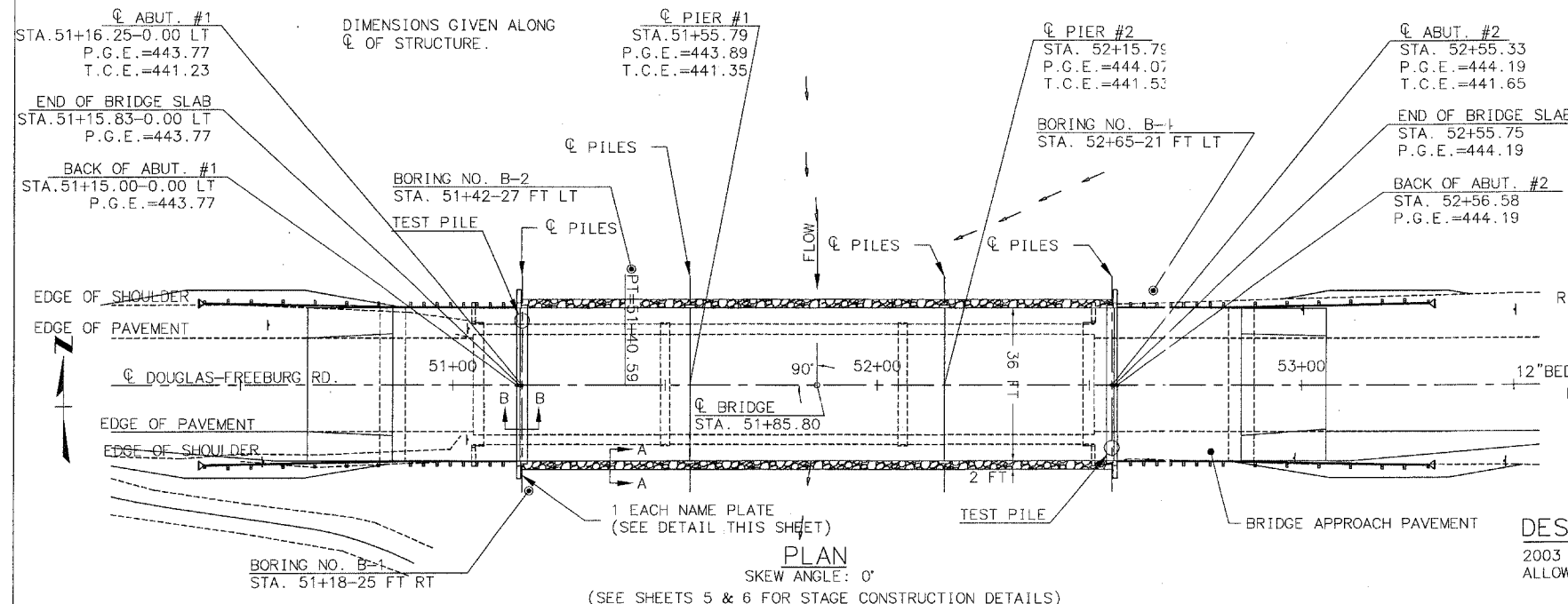

GENERAL NOTES

1. THE CONTRACTOR SHALL DRIVE TWO (2) STEEL HP 12x53 TEST PILES, AS SPECIFIED, IN A PERMANENT LOCATION AS DIRECTED BY THE ENGINEER BEFORE ORDERING THE REMAINING PILES.
2. REFER TO THE SPECIAL PROVISIONS FOR BORING LOG INFORMATION.
3. A CORROSION INHIBITOR, AS COVERED IN THE SPECIAL PROVISIONS, SHALL BE USED IN THE CONCRETE FOR THE PRECAST PRESTRESSED CONCRETE DECK BEAMS.
4. RAILING SHALL BE IN ACCORDANCE WITH SECTION 509 OF THE STANDARD SPECIFICATIONS, EXCEPT AS NOTED ON THE PLANS, AND SHALL BE PAID FOR AT THE CONTRACT UNIT PRICE PER FOOT FOR STEEL RAILING, TYPE SM WHICH PRICE SHALL INCLUDE THE COST OF FURNISHING AND ERECTING.
5. REINFORCEMENT BARS SHALL CONFORM TO THE REQUIREMENTS OF AASHTO M-31, M-42, OR M-53, GRADE 60.
6. THE COST OF STRUCTURE EXCAVATION SHALL BE CONSIDERED INCLUDED IN THE COST OF CONCRETE STRUCTURES.
7. IN ADDITION TO ALL OTHER REQUIREMENTS OF SECTION 512 OF THE STANDARD SPECIFICATIONS, SPLICES FOR STEEL H PILES SHALL DEVELOP FULL CAPACITY OF THE PILE FOR TENSION, SHEAR AND BENDING FORCES. ONE APPROVED METHOD OF ACHIEVING THIS REQUIREMENT IS FULL PENETRATION BUTT WELDING OF THE ENTIRE CROSS SECTION. OTHER TYPES OF SPLICES MEETING THE FULL CAPACITY REQUIREMENT MAY BE ALLOWED SUBJECT TO THE APPROVAL OF THE ENGINEER. ANY PROPOSAL BY THE CONTRACTOR TO USE AN ALTERNATE SPLICE METHOD MUST INCLUDE ADEQUATE DOCUMENTATION DEMONSTRATING THAT THE FULL TENSION, SHEAR AND BENDING CAPACITIES WILL BE MET. APPROPRIATE WELDER QUALIFICATIONS WILL BE REQUIRED FOR THE POSITIONS AND PROCESSES USED IN SPLICING ALL PILES. NONDESTRUCTIVE TESTING OF COMPLETED WELDS WILL BE LIMITED TO VISUAL INSPECTION.

TOTAL BILL OF MATERIALS (STRUCTURE)

ITEM	UNIT	SUPER	SUB		TOTAL
			ABUTS.	PIERS	
CHANNEL EXCAVATION	CU YD				614
STONE DUMPED RIPRAP, CLASS A7	SQ YD				650
FILTER FABRIC	SQ YD				650
BITUMINOUS CONCRETE SURFACE COURSE, SUPERPAVE, MIX "C", N50	TON	94.1			94.1
CONCRETE STRUCTURES	CU YD		40.4	18.2	58.6
PRECAST PRESTRESSED CONCRETE DECK BEAMS (27" DEPTH)	SQ FT	5031			5031
REINFORCEMENT BARS, EPOXY COATED	POUND		3314	1496	4810
STEEL RAILING, TYPE SM	FOOT	280			280
FURNISHING STEEL PILES HP 12x53	FOOT		1049	1950	2999
DRIVING STEEL PILES	FOOT		1049	1950	2999
TEST PILE STEEL HP 12x53	EACH		2		2
CONCRETE ENCASEMENT	CU YD		4.0	44.4	48.4
WATERPROOFING MEMBRANE SYSTEM	SQ YD	560			560
PORTLAND CEMENT MORTAR FAIRING COURSE	FOOT	1120			1120
REMOVAL OF EXISTING STRUCTURES	EACH				1
METAL SHOES	EACH		10	18	28
NAME PLATES	EACH				1
BAR SPLICERS	EACH		36	12	48

DESIGN SPECIFICATIONS

2003 AASHTO, HS-20 LOADING, LOAD FACTOR DESIGN
 ALLOW 25 PSF FOR FUTURE WEARING SURFACE

SEISMIC DATA

S.P.C. = B
 A = 0.120
 S = I/1.0

INDEX OF SHEETS

8. GENERAL PLAN & ELEVATION
9. P.P.C. DECK BEAM SUPERSTRUCTURE (40'-0" SPAN)
10. P.P.C. DECK BEAM SUPERSTRUCTURE (60'-0" SPAN)
11. P.P.C. DECK BEAM DETAILS
12. P.P.C. DECK BEAMS PILE BENT ABUTMENT
13. P.P.C. DECK BEAMS PILE BENT PIER
14. STANDARD CN
15. STANDARD CR-TSM
16. STANDARD CX-1

PILE DATA (2-ABUTMENTS)

TYPE: HP 12x53 (W/ METAL SHOES)
 CAPACITY: DRIVEN TO REFUSAL
 ESTIMATED LENGTH: 104 FT (ABUTMENT #1)
 107 FT (ABUTMENT #2)
 NUMBER REQUIRED: 12 (INCLUDES TWO TEST PILES TO BE DRIVEN AT THE LOCATIONS SHOWN ON THE PLANS)

PILE DATA (2-PIERS)

TYPE: HP 12x53 (W/ METAL SHOES)
 CAPACITY: DRIVEN TO REFUSAL
 ESTIMATED LENGTH: 108 FT (PIER #1)
 108 FT (PIER #2)
 NUMBER REQUIRED: 18 EACH

DESIGN STRESSES

FIELD UNITS
 f'c = 3500 psi fy = 60000 psi

PRECAST PRESTRESSED UNITS

f'c = 5000 psi
 f'ci = 4000 psi
 f's = 270000 psi (1/2" STRESSED RELIEVED STRANDS)
 f'si = 189000 psi (1/2" STRESSED RELIEVED STRANDS)
 fy = 60000 psi

I CERTIFY THAT TO THE BEST OF MY KNOWLEDGE, INFORMATION AND BELIEF, THIS BRIDGE DESIGN IS STRUCTURALLY ADEQUATE FOR THE DESIGN LOADING SHOWN ON THE PLANS. THE DESIGN IS AN ECONOMICAL ONE FOR THE STYLE OF STRUCTURE AND COMPLIES WITH THE REQUIREMENTS OF THE CURRENT AASHTO STANDARD SPECIFICATIONS FOR HIGHWAY BRIDGES.

Robert A. Bruckner
 June 20, 2005

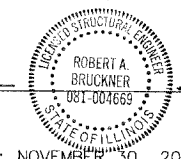

ROBERT A. BRUCKNER, SE
 LICENSE NO. 081-004669
 LICENSE EXPIRATION DATE: NOVEMBER 30, 2006

P.G.E. = PROFILE GRADE ELEVATION
 T.C.E. = TOP OF CAP ELEVATION

BENCHMARK: FOUND CHISELED SQUARE
 TOP OF S.W. WINGWALL ELEVATION = 443.52 FT.

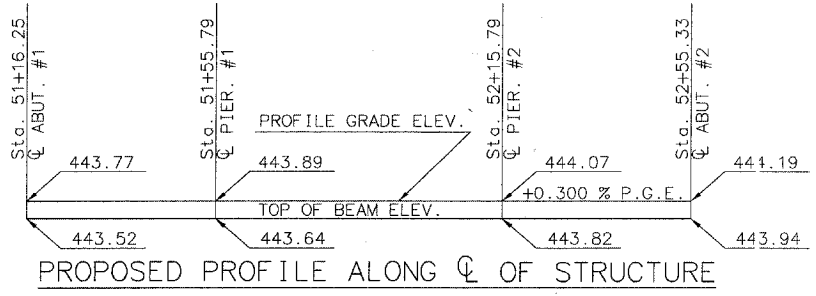
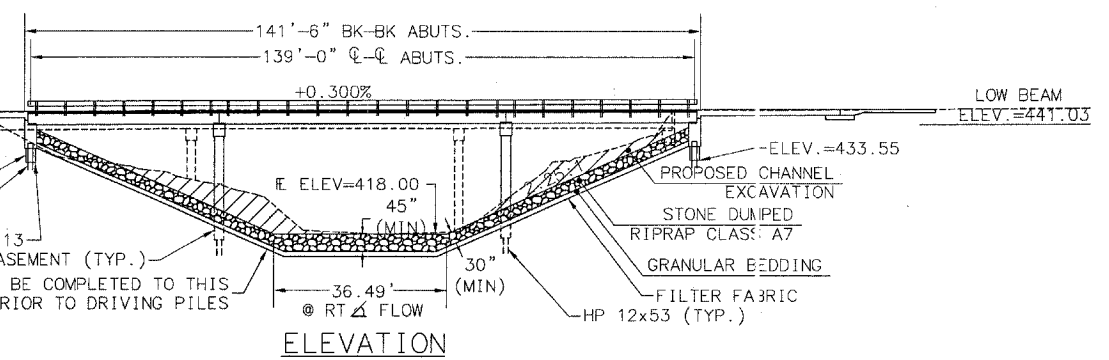
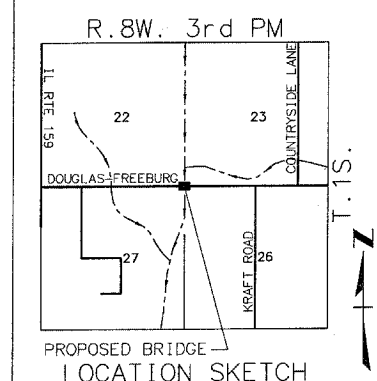

WATERWAY INFORMATION

DRAINAGE AREA = 53.56 sq.mi. LOW RWY. ELEV. = 442.26 @ Sta. 45+50

FLOOD	FREQ. YR.	Q cfs	OPENING sq. ft.		NAT. H.W.E. ft	HEAD ft		HEADWATER ELEV. - ft	
			EXIST.	PROP.		EXIST.	PROP.	EXIST.	PROP.
DESIGN	30	14500	1406	1632	438.50	1.80	1.66	440.30	440.16
BASE	100	18500	1521	1745	439.40	3.20	3.16	442.60	442.56

OVER-THE-ROAD FLOW AREA: ① 150 SQFT
 ② 126 SQFT

RICHLAND CREEK
 BUILT 20 BY
 ST. CLAIR COUNTY
 SEC. 00-00196-08-BR
 C.H. 47 STA. 51+85.80
 PROJ. BRS 840(102)
 STR. NO. 082-3101 LOADING HS-20

LETTERING FOR NAME PLATE

LOCATE NAME PLATE AT S.W. WINGWALL
 CORNER OF BRIDGE (SEE STD. 515001-02)

GENERAL PLAN & ELEVATION

C.H. 47
 RICHLAND CREEK

SECTION 00-00196-08-BR
 ST. CLAIR COUNTY
 STATION 51+85.80
 S.N. 082-3031

PLOT DATE:

SECTION NO.	COUNTY HIGHWAY	COUNTY	SHEET
00-00196-08-BR	47	ST. CLAIR	9 OF 18
FHWA REG. NO. 7	ILLINOIS	FEDERAL AID PROJECT	
CONTRACT 97257			

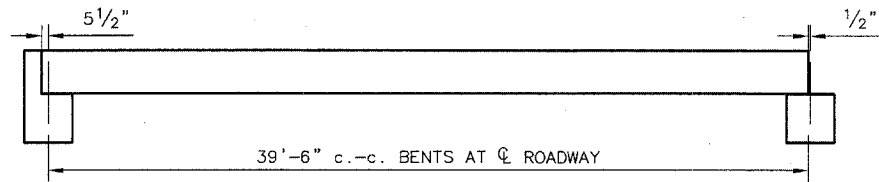

TYPICAL ELEVATION

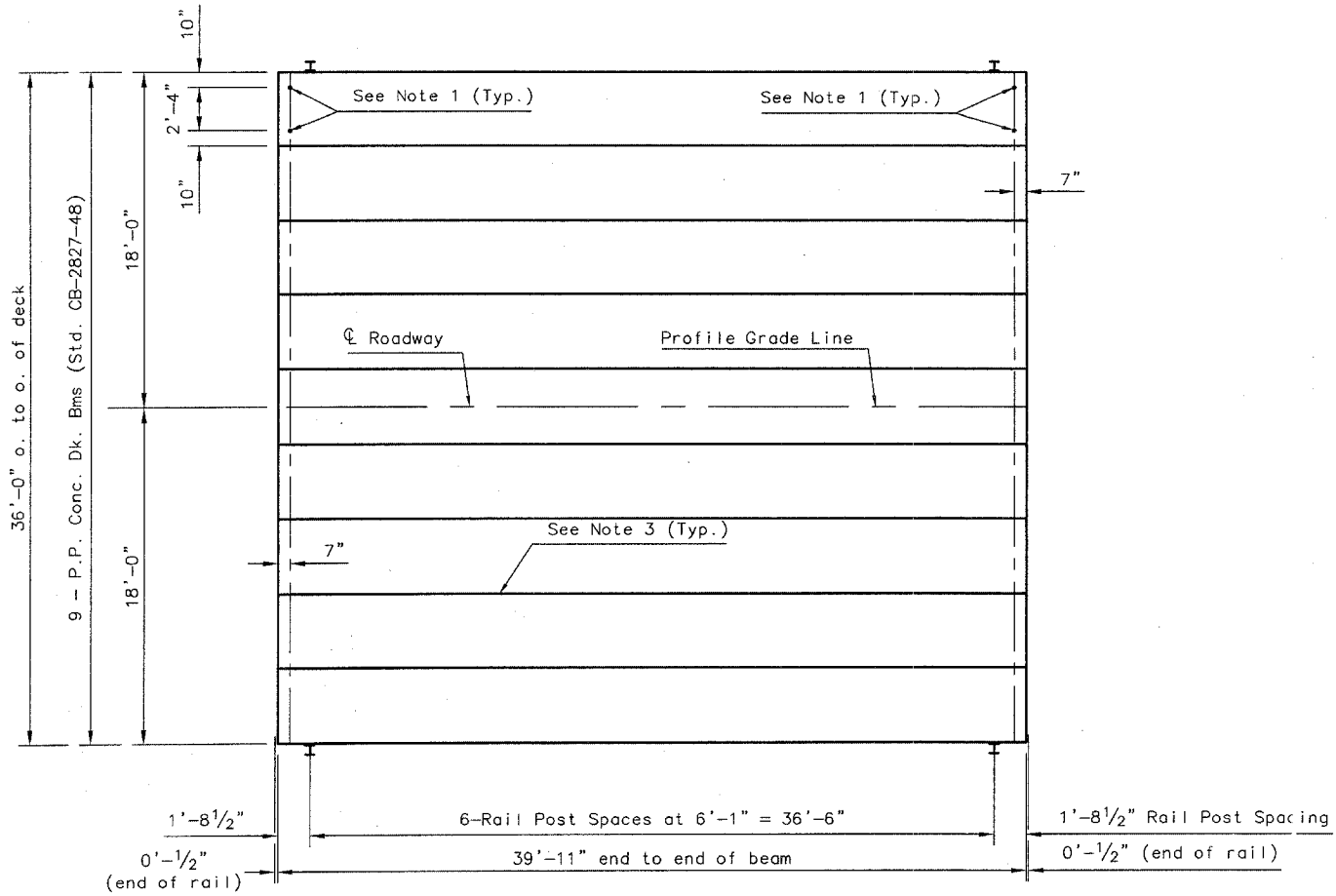

PLAN

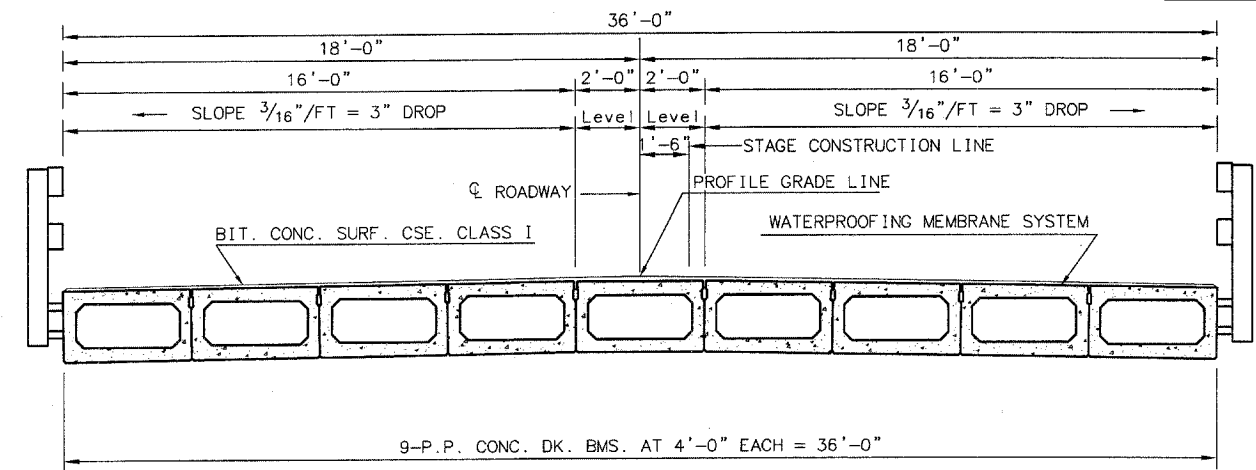

CROSS SECTION
(LOOKING EAST)

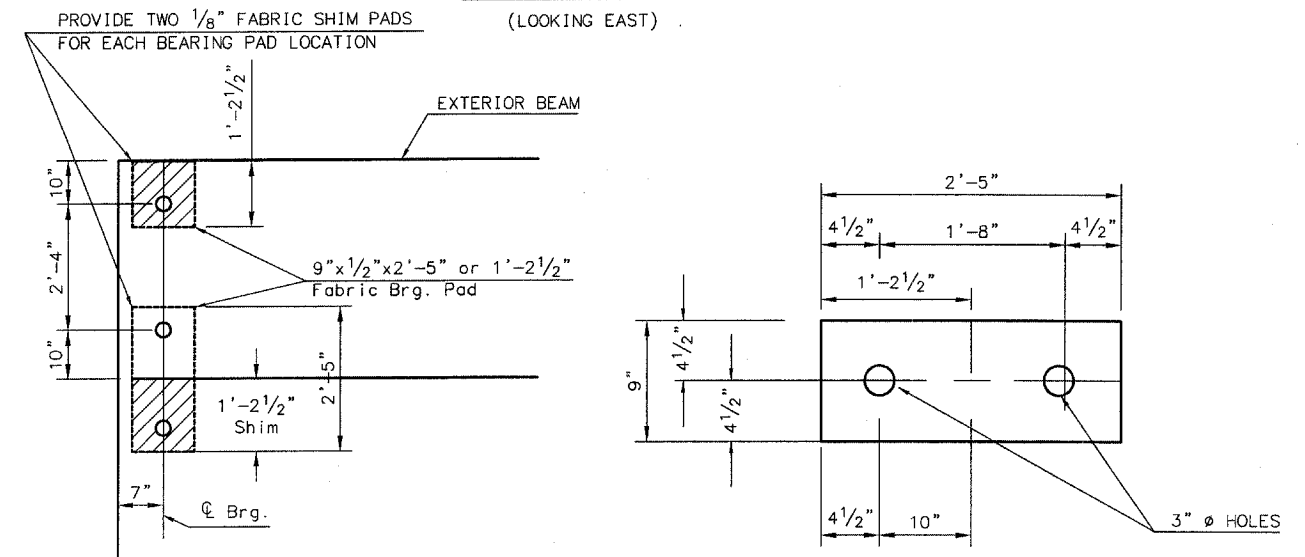

1/2" FABRIC BRG. PAD DETAILS

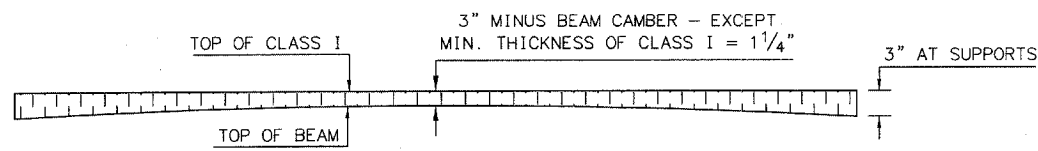

PROFILE OF OVERLAY

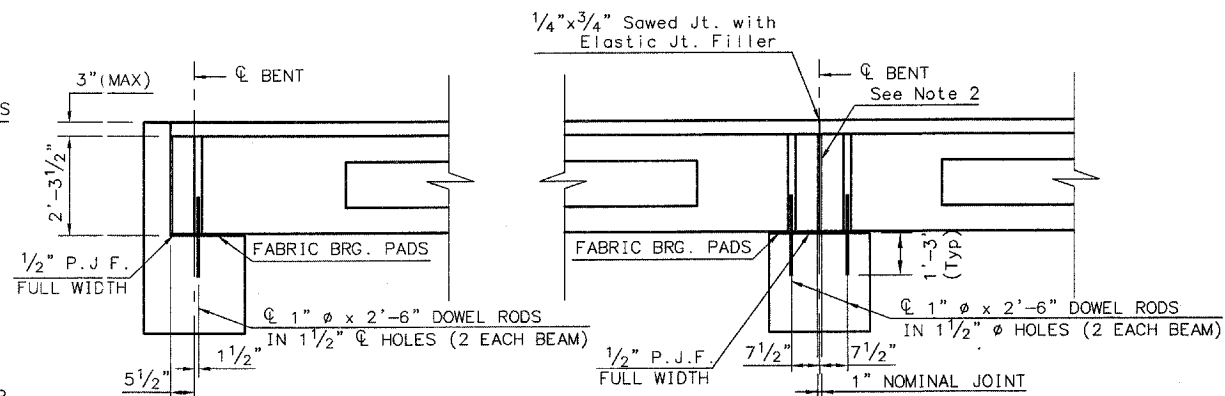

SECTION AT ABUTS.

(ALONG ϕ BEAMS)

SECTION AT PIERS

(ALONG ϕ BEAMS)

QUANTITIES FOR ONE SPAN

P.P. CONC. DK. BM. 27" DP.	1437 SQ FT
STEEL RAILING, TYPE SI	80 FT
BCSC SUPER "C" N50	31 TONS
WATERPROOFING MEMBRANE SYSTEM	159.7 SQ YD

P.P.C. DECK BEAM
SUPERSTRUCTURE

36' RDWY.	27" BMS.
40' SPAN	0° SKEW

NOTES

- AFTER BEAMS HAVE BEEN ERECTED, HOLES SHALL BE DRILLED INTO SUBSTRUCTURE AND ANCHOR DOWELS PLACED. DOWEL HOLES SHALL BE FILLED WITH NON-SHRINK GROUT TO TOP OF BEAM AND ALLOWED TO CURE MIN. 24 HRS. PRIOR TO GROUTING THE SHEAR KEYS.
- NOMINAL 1" JOINT AT ϕ PIER SHALL BE FILLED WITH NON-SHRINK GROUT.
- LONGITUDINAL KEYS SHALL BE GROUTED.
- SEE SHEET 3 FOR SHEAR KEY CLAMPING DETAILS.
- SEE SHEETS 5 & 6 FOR STAGE CONSTRUCTION DETAILS.

DESIGNED	INITIALS	DATE
CHECKED	JLH	8/04
DRAWN	JLH	10/04
CHECKED		
PREPARED BY ST. CLAIR COUNTY		
CADD DRAWING FILE: SUPERSTR		

SECTION NO.	COUNTY HIGHWAY	COUNTY	SHEET
00-00196-08-BR	47	ST. CLAIR	10 OF 18
FHWA REG. NO. 7	ILLINOIS	FEDERAL AID PROJECT	
CONTRACT 97257			

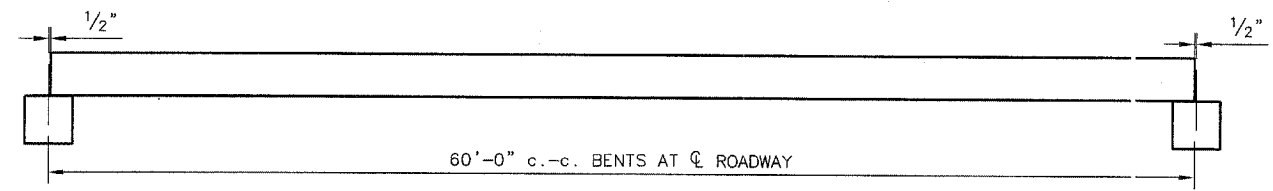

TYPICAL ELEVATION

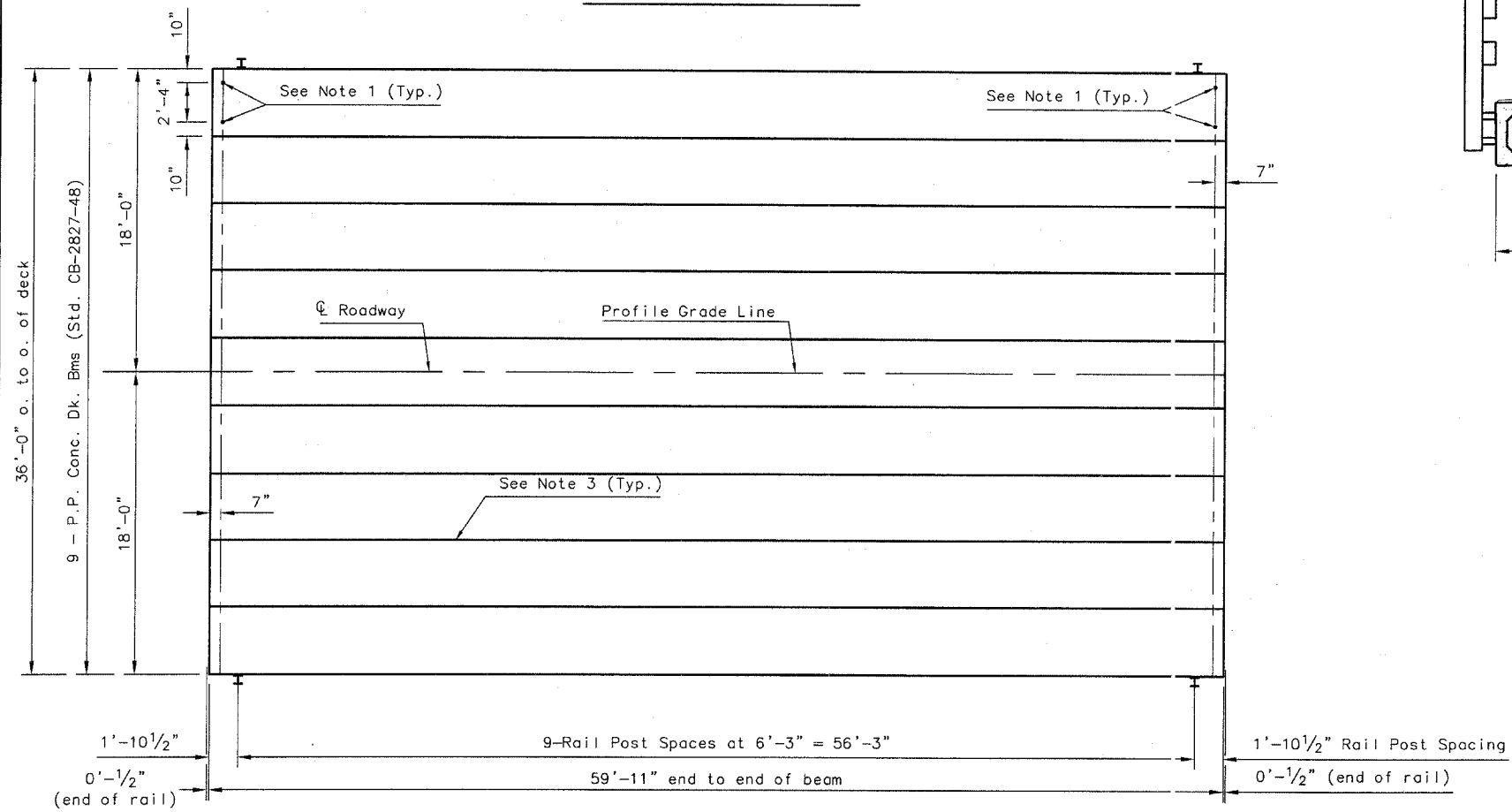

PLAN

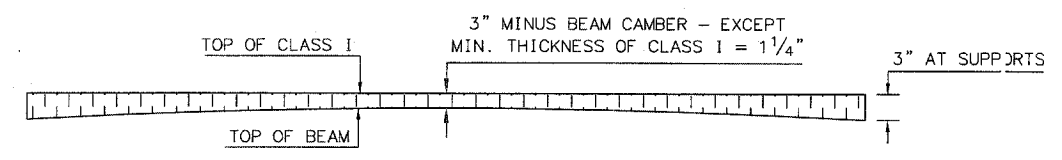

PROFILE OF OVERLAY

NOTES

- AFTER BEAMS HAVE BEEN ERECTED, HOLES SHALL BE DRILLED INTO SUBSTRUCTURE AND ANCHOR DOWELS PLACED. DOWEL HOLES SHALL BE FILLED WITH NON-SHRINK GROUT TO TOP OF BEAM AND ALLOWED TO CURE MIN. 24 HRS. PRIOR TO GROUTING THE SHEAR KEYS.
- NOMINAL 1" JOINT AT ϕ PIER SHALL BE FILLED WITH NON-SHRINK GROUT.
- LONGITUDINAL KEYS SHALL BE GROUTED.
- SEE SHEET 3 FOR SHEAR KEY CLAMPING DETAILS.
- SEE SHEETS 5 & 6 FOR STAGE CONSTRUCTION DETAILS.

INITIALS	DATE
DESIGNED JLH	8/04
CHECKED	
DRAWN JLH	10/04
CHECKED	
PREPARED BY ST. CLAIR COUNTY	
CADD DRAWING FILE: SUPERSTR	

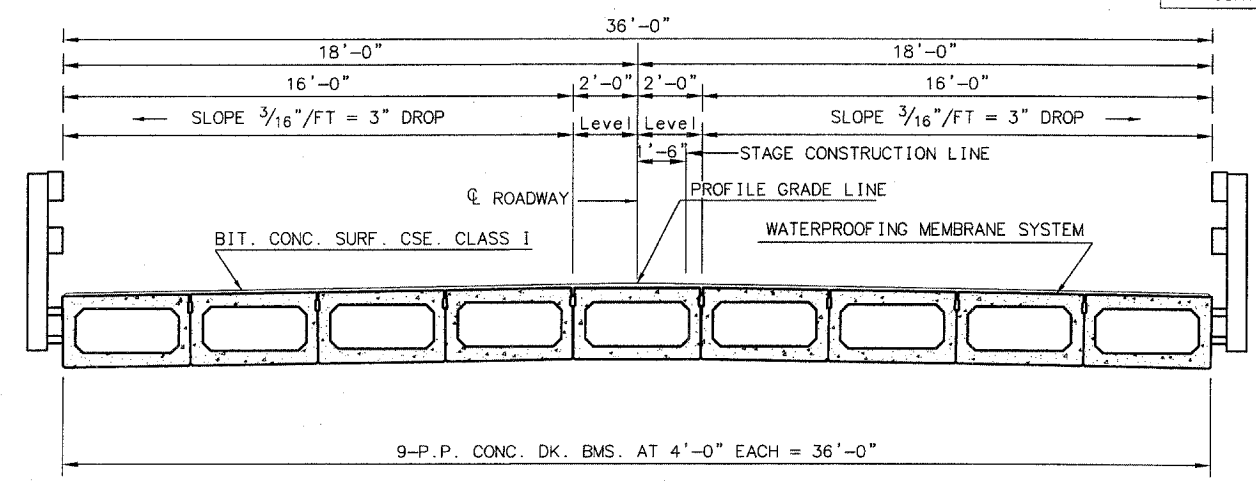

CROSS SECTION (LOOKING EAST)

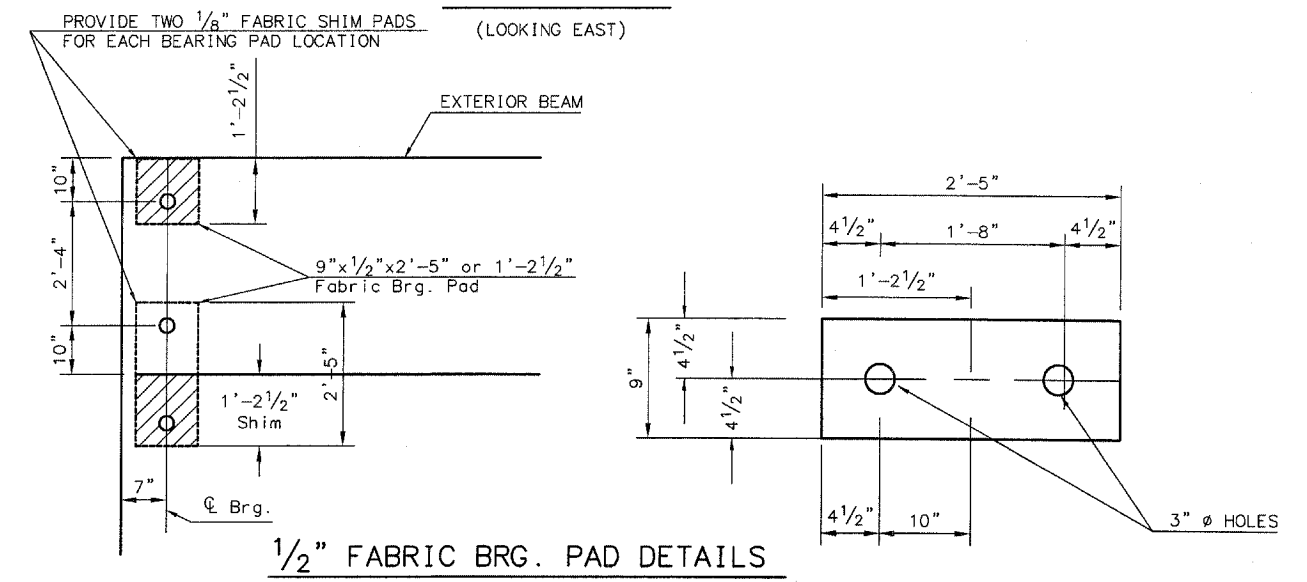

1/2" FABRIC BRG. PAD DETAILS

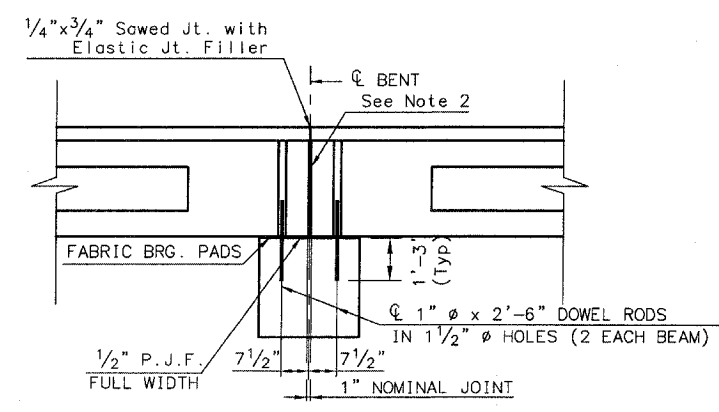

SECTION AT PIERS (ALONG ϕ BEAMS)

QUANTITIES FOR ONE SPAN

P.P. CONC. DK. BM. 27" DP.	2157 SQ FT
STEEL RAILING, TYPE S1	120 FT
BCSC SUPER "C" N50	28.2 TONS
WATERPROOFING MEMBRANE SYSTEM	240 SQ YD

P.P.C. DECK BEAM SUPERSTRUCTURE	
36' RDWY.	27" BMS.
60' SPAN	0° SKEW

SECTION NO.	COUNTY HIGHWAY	COUNTY	SHEET OF SHEETS
00-00196-08-BR	47	ST. CLAIR	11 OF 18
FHWA REG. NO. 7 ILLINOIS		FEDERAL AID PROJECT	
CONTRACT 97257			

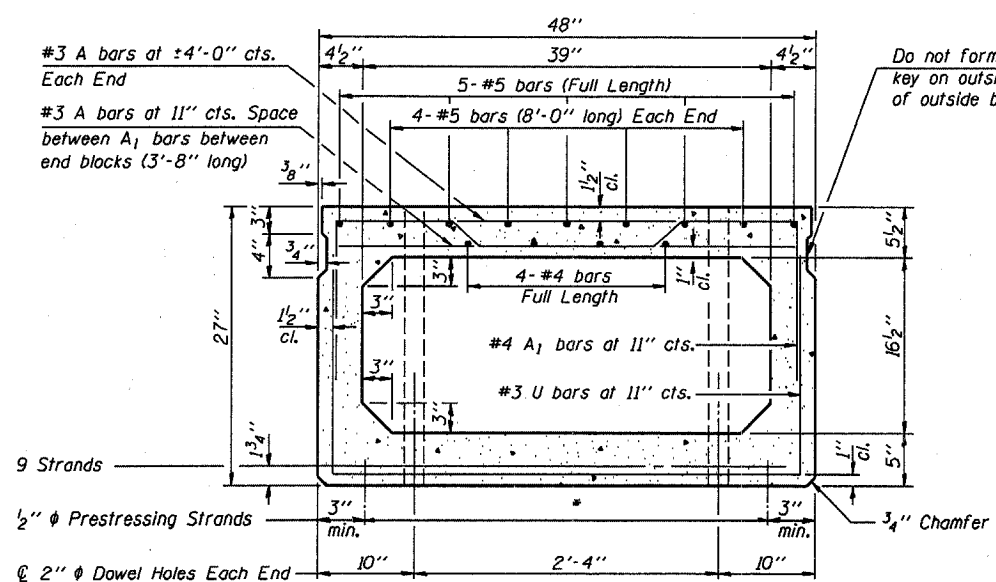

CROSS SECTION
(40' SPAN)

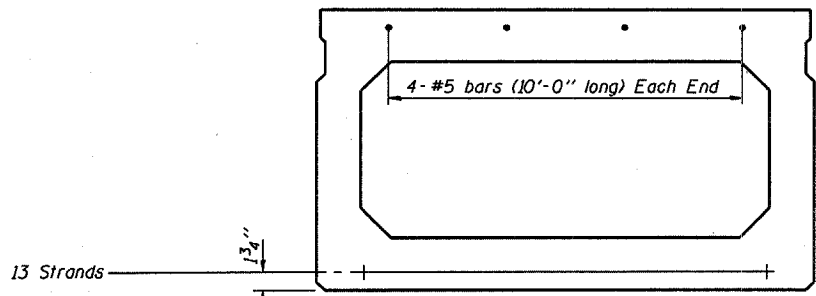

CROSS SECTION
(50' SPAN)

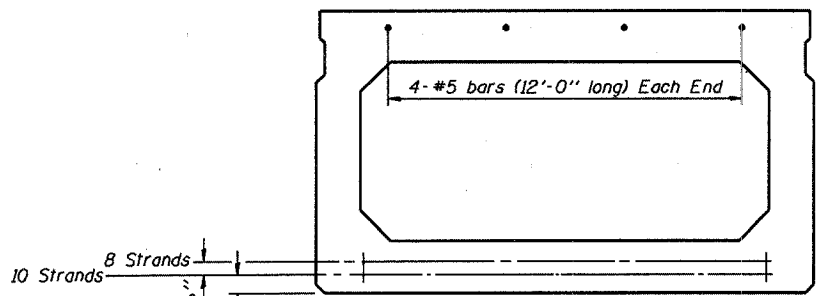

CROSS SECTION
(60' SPAN)

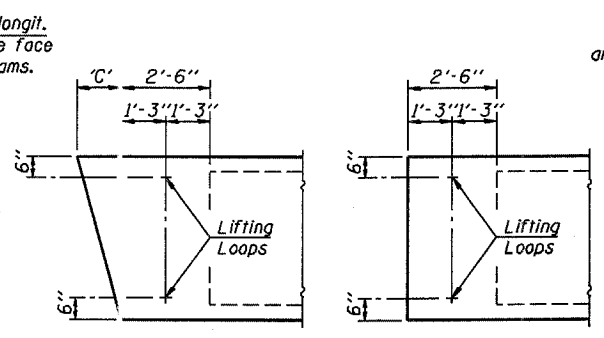

END BLOCK DETAILS

Each beam shall have four Lifting Loops, two at each end of beam cast in locations shown above. Loops shall be burned off after beams have been erected.

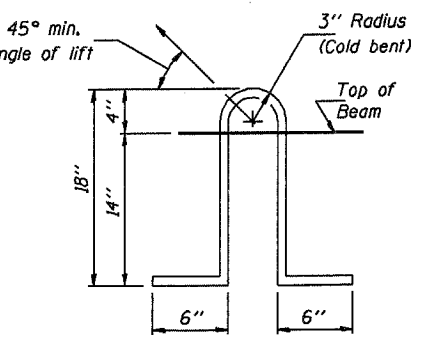

LIFTING LOOP DETAIL

Lifting loops shall be 3, 1/2 inch diameter 270 ksi strands, as shown. Alternate approved lifting devices are also acceptable.

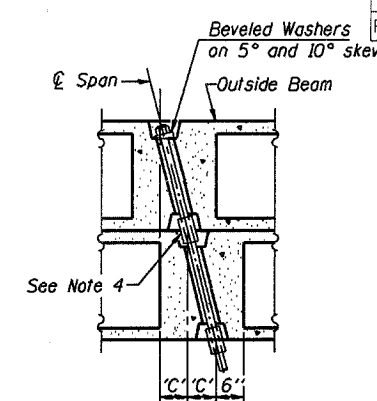

PARTIAL PLAN TRANSVERSE TIE ASSEMBLY
(D=0°, 5° and 10°)

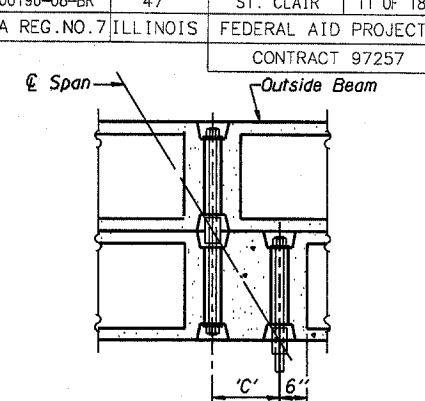

PARTIAL PLAN TRANSVERSE TIE ASSEMBLY
(D=15°, 20°, 25° and 30°)

DIMENSION 'C'

Skew Angle 'D'	0°	5°	10°	15°	20°	25°	30°
Dimension 'C' (Inches)	0	4 1/4	8 1/2	12 3/4	17 1/2	22 3/8	27 3/4

*** TRANSVERSE STRAND PLACEMENT GUIDELINES**

1. Place strands symmetrically about centerline of beam.
2. The minimum distance from center to center of strands in all directions shall be 2".
3. The minimum clearance from strand to dowel hole shall be 1/2".
4. The minimum clearance from strand to void shall be 1 1/2".

Vertical placement of strands shall not be adjusted to satisfy the above guidelines.

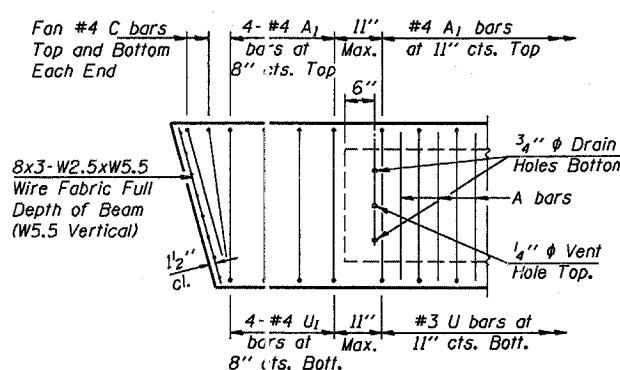

END REINFORCEMENT
(SKEWED)

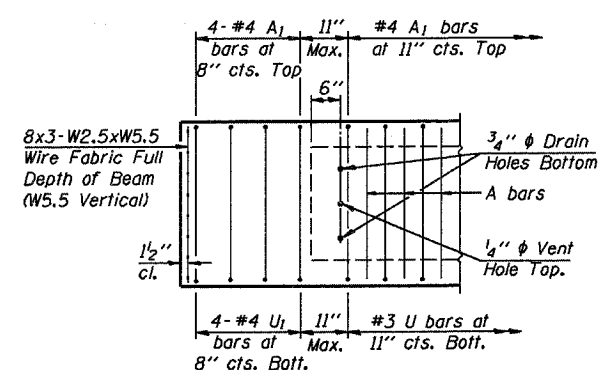

END REINFORCEMENT
(RIGHT ANGLE)

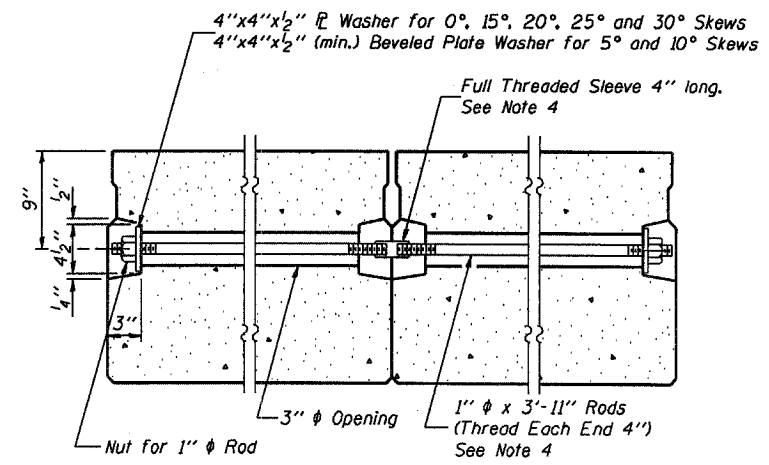

SECTION ALONG TRANSVERSE TIE ASSEMBLY
(REQUIRED FOR 50' & 60' SPANS ONLY)

NOTES

1. Prestressing steel shall be uncoated high strength, low relaxation 7-wire strand, Grade 270.
2. The nominal diameter shall be 1/2 inch and the nominal cross-sectional area shall be 0.153 square inches.
3. Reinforcement bars shall conform to the requirements of AASHTO M-31 or M-322, Grade 60.
4. On 0°, 5° and 10° skews, alternate approved transverse tie rods of increased segmental length are acceptable.
5. Rail Post anchor devices shall be cast into outside beam as elsewhere specified.
6. When a Waterproofing Membrane System is specified, the top surface of the beams shall be screeded with a straightedge and finished with a hand float. The finished surface shall be free of depressions or high spots with sharp corners and the top edge of keys shall be rounded or chamfered a minimum of 1/4 inch.
7. Keyway surfaces shall be cleaned to remove form oil or other bond breaking material prior to shipment of the beams. Cleaning shall be done by sandblasting the keyway areas between the top of the beam and the bottom edge of the key.

BAR C**

BAR A1

BARS U & U1

DESIGN STRESSES

$f'_c = 5,000$ p.s.i.
 $f'_{ci} = 4,000$ p.s.i.
 $f'_s = 270,000$ p.s.i. (1/2 inch diameter Strand)
 $f_{si} = 201,960$ p.s.i. (1/2 inch diameter Strand)
 $f_y = 60,000$ p.s.i.

MIN. BAR LAP

#4 bars = 1'-4"
 #5 bars = 1'-8"

NOTE
 The std. reinf. and dimensions shown on the 40' span cross section is typical for all spans, except as shown.

****NOTE:**
 The following number of C bars shall be used:
 Skew No.
 5° and 10° — 1
 15° and 20° — 2
 25° and 30° — 3

Illinois Department of Transportation
 PASSED APRIL 4, 2005
 Approved by: *Thomas S. Hennig*
 Engineer of Bridge Design
 APPROVED APRIL 4, 2005
 Approved by: *Ralph E. Anderson*
 Engineer of Bridges and Structures

P.P.C. DECK BEAM DETAILS
 28" ROADWAY | 27" x 48" BEAMS
 STANDARD CB-2827-48

SECTION NO.	COUNTY HIGHWAY	COUNTY	SHEET OF SHEETS
00-00196-08-BR	47	ST. CLAIR	12 OF 18
FHWA REG.NO.7	ILLINOIS	FEDERAL AID PROJECT	
CONTRACT 97257			

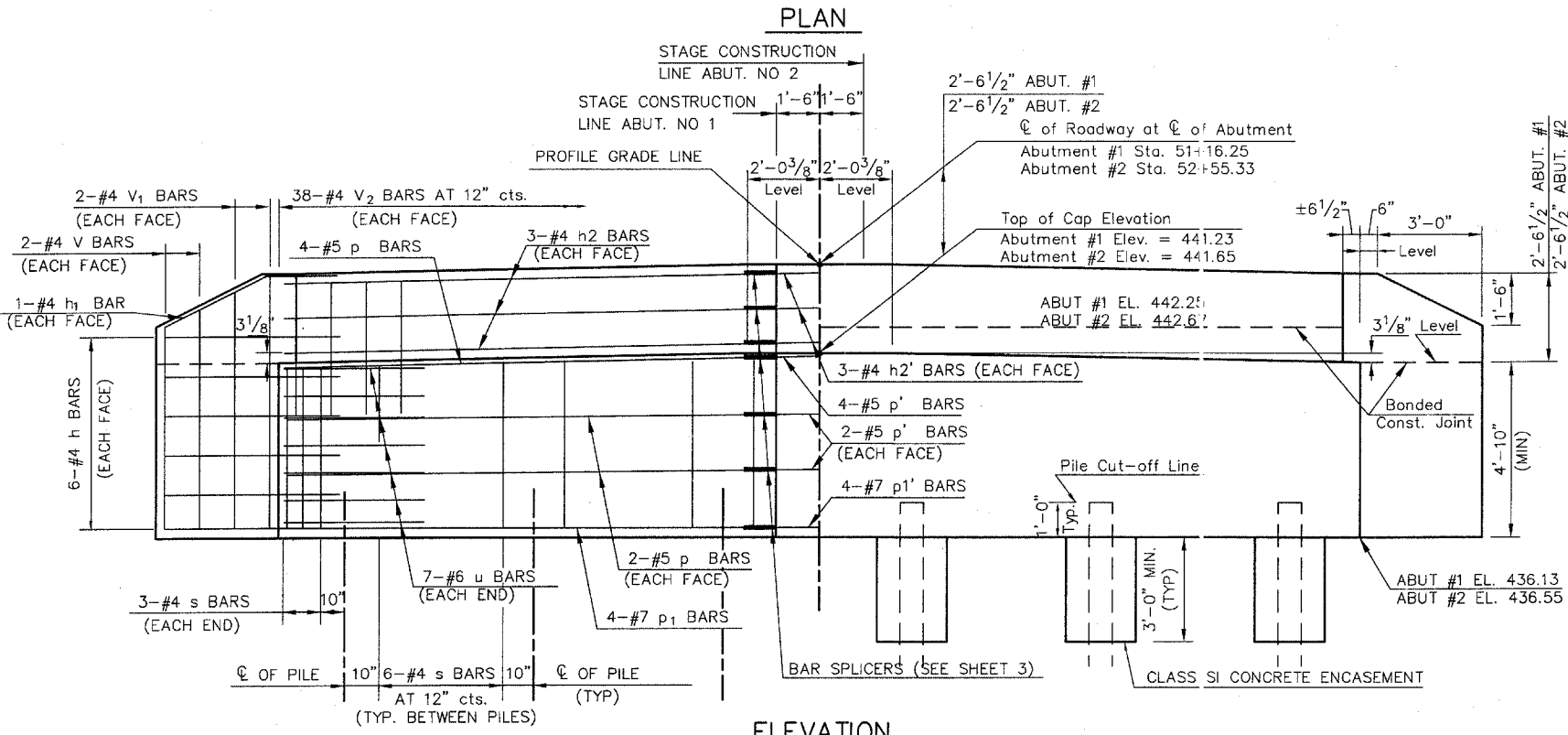
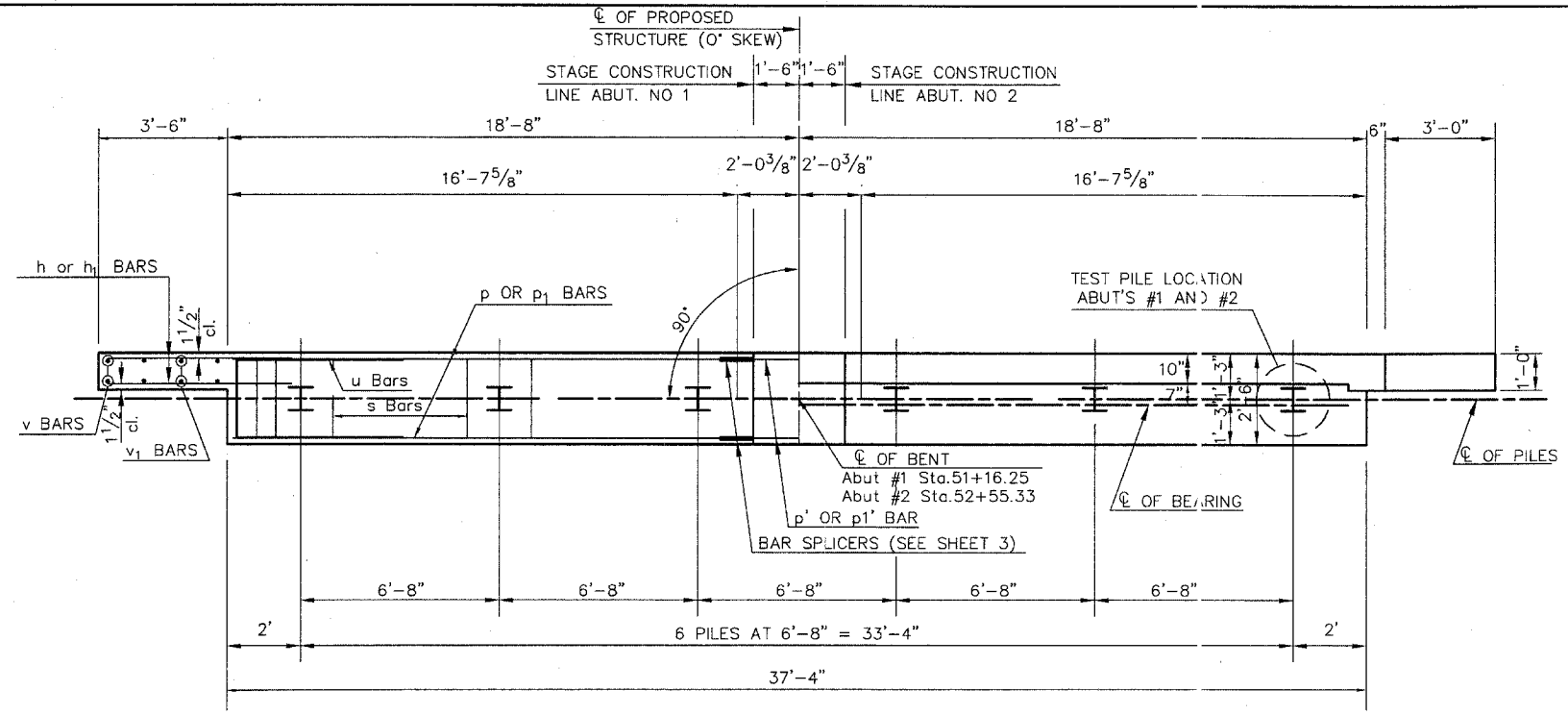

NOTES

- THE BACKWALL AND THE PORTION OF THE WINGWALLS ABOVE THE BONDED CONSTRUCTION JOINT SHALL BE CAST AGAINST THE IN-PLACE BEAM.
- REINFORCEMENT BARS SHALL CONFORM TO A.A.S.H.T.O. M-31, M-42 or M-53. GRADE 60.
- ALL REINFORCEMENT BARS SHOWN SHALL BE EPOXY COATED
- SEE SHEETS 5 & 6 FOR STAGE CONSTRUCTION DETAILS.

PILE DATA (2-ABUTMENTS)

TYPE: HP 12x53 (W/ METAL SHOES)
 CAPACITY: DRIVEN TO REFUSAL
 ESTIMATED LENGTH: 104 FT (ABUTMENT #1)
 107 FT (ABUTMENT #2)
 NUMBER REQUIRED: 18 (INCLUDES TWO TEST PILES TO BE DRIVEN AT THE LOCATION SHOWN ON THE PLANS)

SECTION THRU ABUTMENT
(AT RIGHT ANGLES)

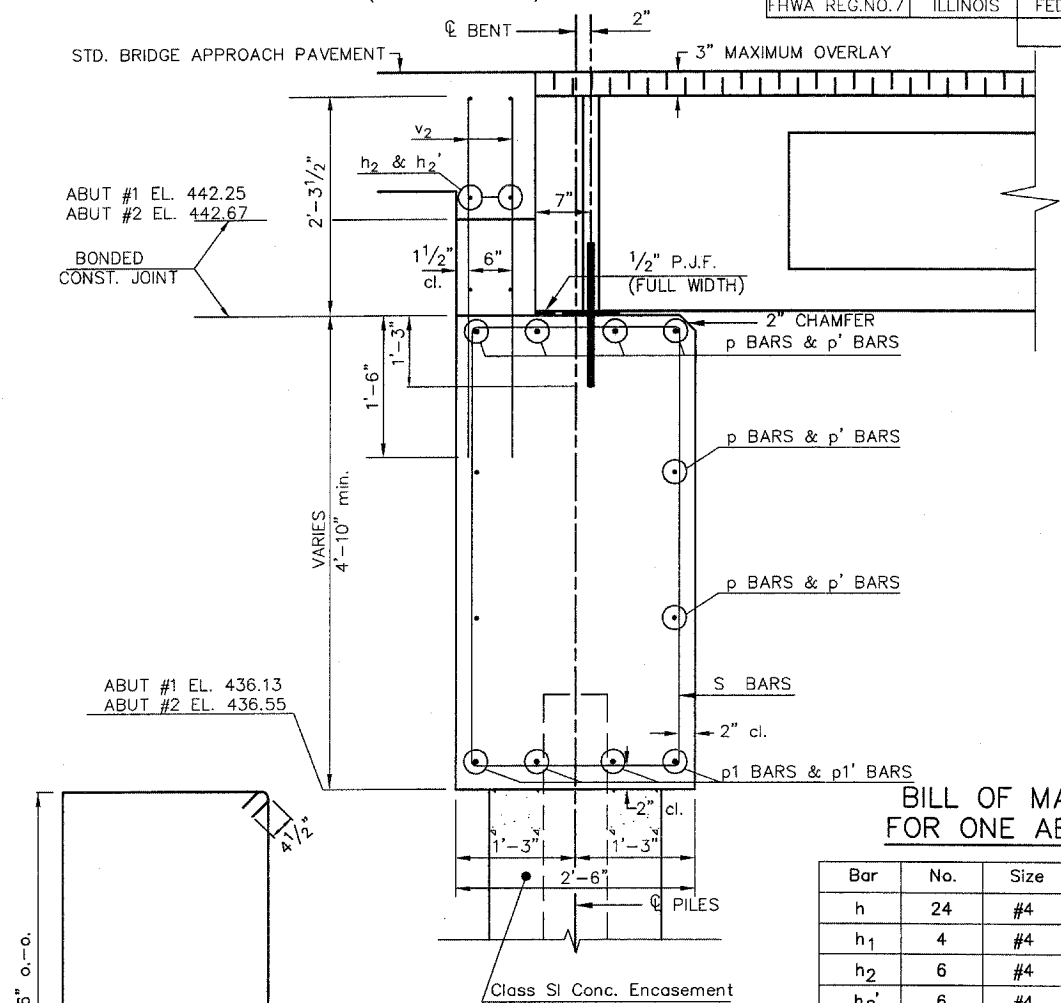

BILL OF MATERIAL FOR ONE ABUTMENT

Bar	No.	Size	Length	Shape
h	24	#4	5'-0"	—
h ₁	4	#4	5'-3"	—
h ₂	6	#4	16'-9 1/2"	—
h ₂ '	6	#4	19'-10 1/2"	—
p	8	#5	16'-9 1/2"	—
p'	8	#5	19'-10 1/2"	—
p ₁	4	#7	16'-9 1/2"	—
p ₁ '	4	#7	19'-10 1/2"	—
s	36	#4	14'-1"	□
u	14	#6	11'-1"	□
v	8	#4	3'-2"	—
v ₁	8	#4	4'-2"	—
v ₂	76	#4	3'-11"	—

QUANTITIES FOR ONE ABUTMENT

CONCRETE STRUCTURES	20.2 CU YD
REINFORCEMENT BARS, EPOXY COATED	1657 LBS
CONCRETE ENCASMENT	2.0 CU YD
METAL SHOES	5 EACH
BAR SPLICERS	18 EACH

**P.P.C. DECK BEAMS
PILE BENT ABUTMENT**

36' RDWY. 27" BMS.
0° SKEW

INITIALS	DATE	DESIGN STRESS
DESIGNED JLH	10/04	f _c = 3500 psi f _y = 60000 psi
CHECKED —	—	
DRAWN JLH	10/04	MAXIMUM PILE LOAD
CHECKED —	—	40' SPAN = 29 TONS 60' SPAN = 42 TONS
PREPARED BY ST. CLAIR COUNTY CADD DRAWING FILE: ABUTMENT		

SECTION NO.	COUNTY HIGHWAY	COUNTY	SHEET OF SHEETS
00-00196-08-BR	47	ST. CLAIR	13 OF 18
FHWA REG.NO.7	ILLINOIS	FEDERAL AID PROJECT	
CONTRACT 97257			

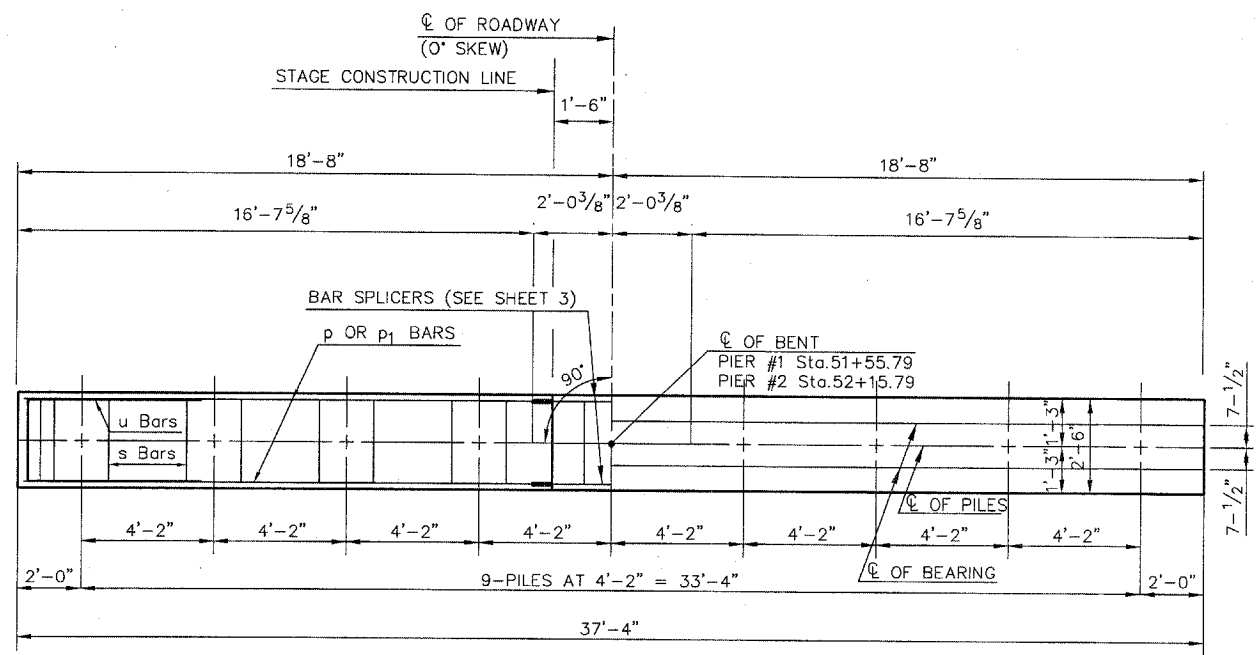

PLAN
(0° SKEW)

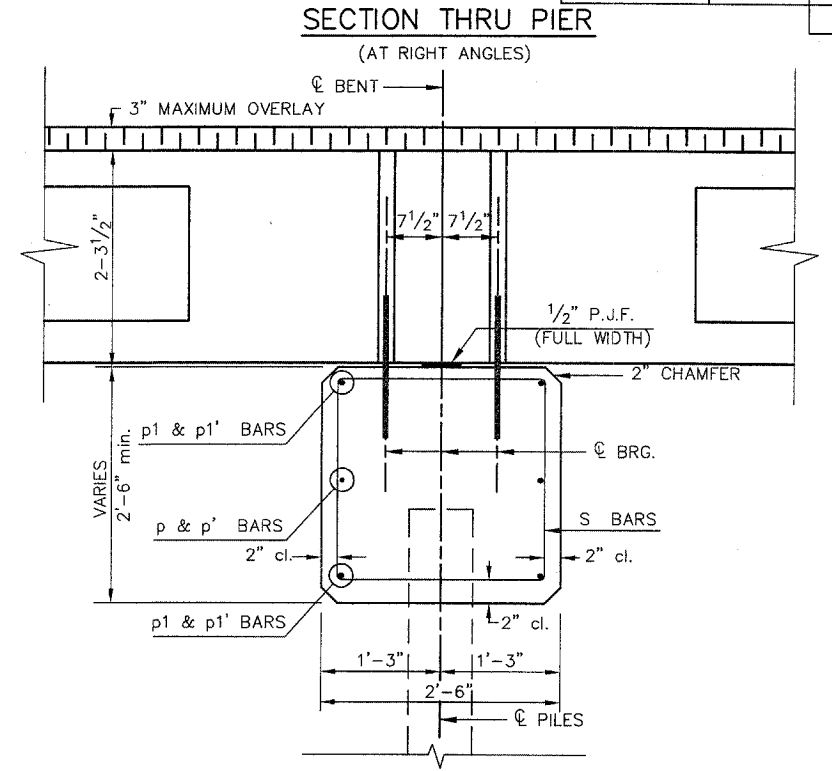

PILE DATA (2-PIERS)

TYPE: HP 12x53 (W/ METAL SHOES)
 CAPACITY: DRIVEN TO REFUSAL
 ESTIMATED LENGTH: 108 FT (PIER #1)
 108 FT (PIER #2)
 NUMBER REQUIRED: 18 EACH

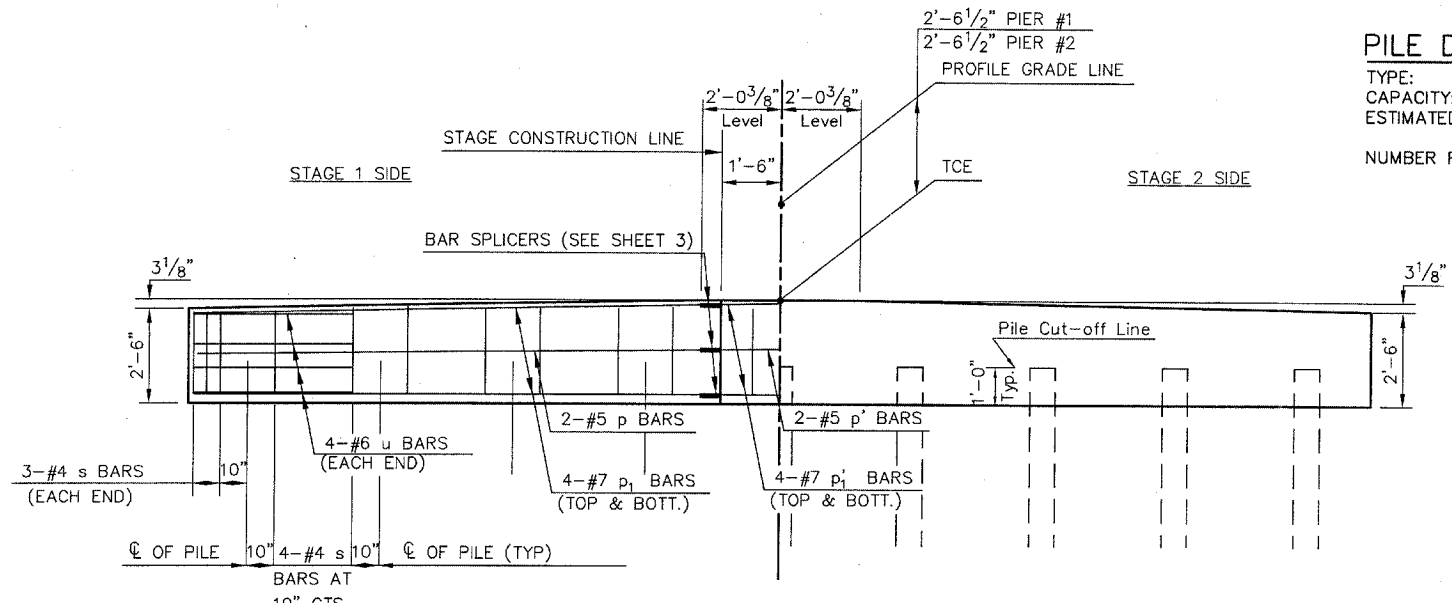

ELEVATION
(LOOKING WEST)

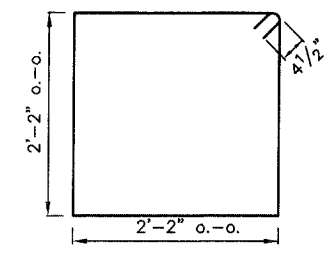

BAR s

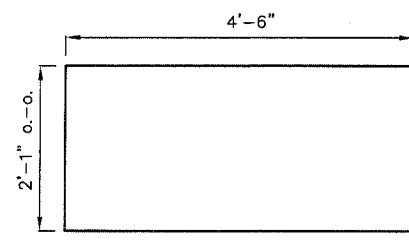

BAR u

BILL OF MATERIAL FOR ONE PIER

Bar	No.	Size	Length	Shape
p	2	#5	16'-9 1/2"	—
p'	2	#5	19'-10 1/2"	—
p ₁	4	#7	16'-9 1/2"	—
p' ₁	4	#7	19'-10 1/2"	—
s	38	#4	9'-5"	□
u	8	#6	11'-1"	▭
CONCRETE STRUCTURES			9.1 CU YDS	
REINFORCEMENT BARS			748 LBS	
BAR SPLICERS			6 EACH	

MAXIMUM PILE LOADS

SPAN	TONS
40'	32
50'	37
60'	42

DESIGN STRESS
 f_c = 3500 psi
 f_y = 60000 psi

NOTE
 REINFORCEMENT BARS SHALL CONFORM TO
 A.A.S.H.T.O. M-31, M-42 OR M-53. GRADE 60.

	INITIALS	DATE
DESIGNED	JLH	10/04
CHECKED	—	—
DRAWN	JLH	10/04
CHECKED	—	—
PREPARED BY ST. CLAIR COUNTY		
CADD DRAWING FILE: PIER		

P.P.C. DECK BEAMS
 PILE BENT PIER
 36' RDWY. 27" BMS.
 0° SKEW

SECTION NO.	COUNTY HIGHWAY	COUNTY	SHEET OF SHEETS
00-00196-08-BR	47	ST. CLAIR	14 OF 18
FHWA REG. NO. 7 ILLINOIS		FEDERAL AID PROJECT	
CONTRACT 97257			

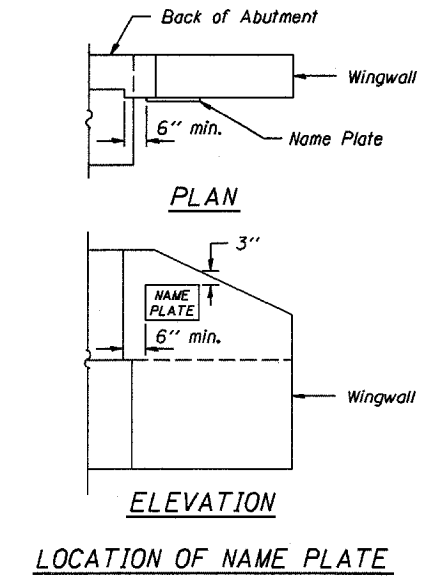
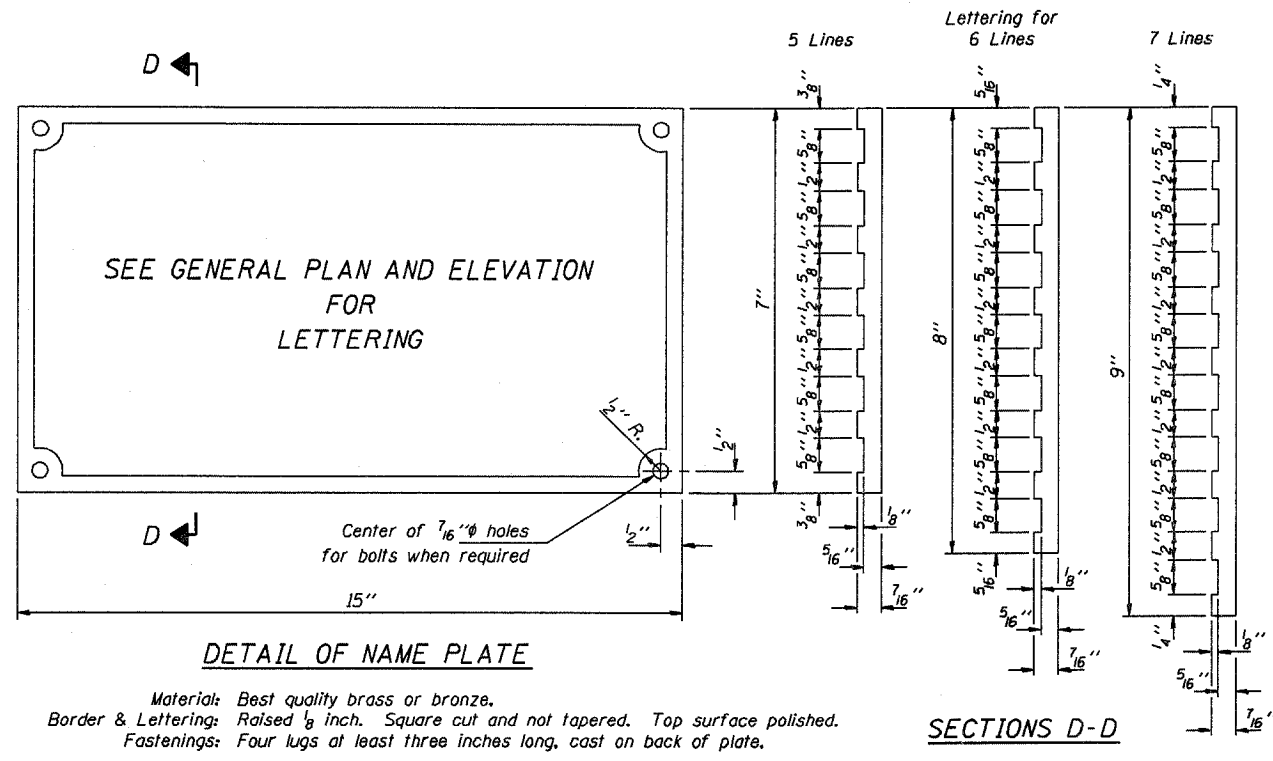

Illinois Department of Transportation

PASSED APRIL 4, 2005
Thomas S. Nemaalaki
 Engineer of Bridge Design

APPROVED APRIL 4, 2005
Ralph E. Anderson
 Engineer of Bridges and Structures

ISSUED 7-1-89 56

NAME PLATE
 STANDARD CN

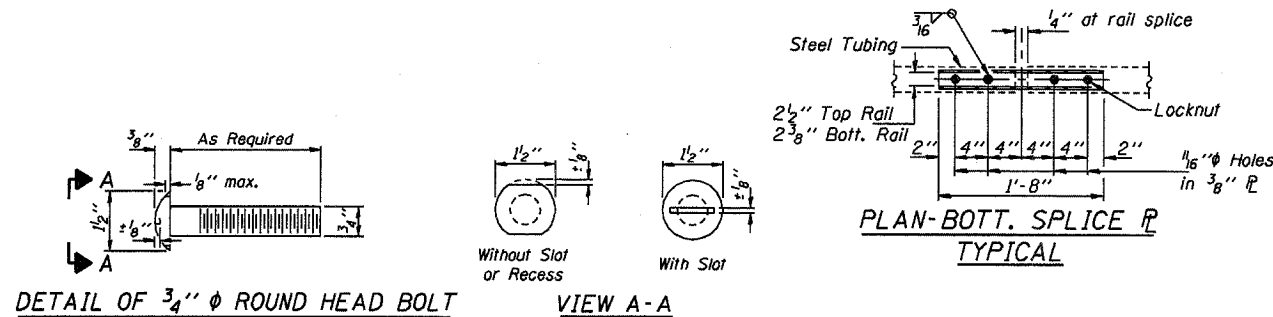

DETAIL OF 3/4" ϕ ROUND HEAD BOLT

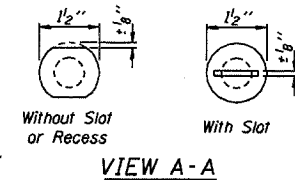

VIEW A-A

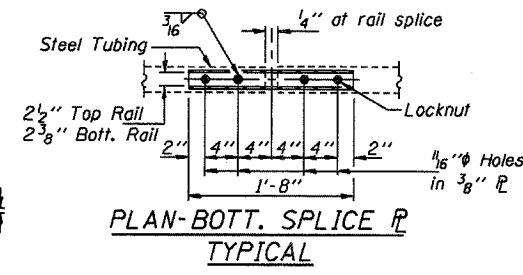

PLAN-BOTT. SPLICE TYPICAL

ϕ - 5/8" reduced base welded studs. Provide 4 - 5/8" washers and self-locking nuts or nuts and jam nuts for guardrail connection shown on Std. 631032

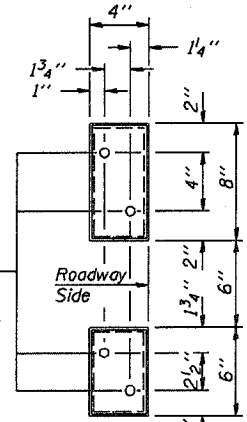

VIEW B-B

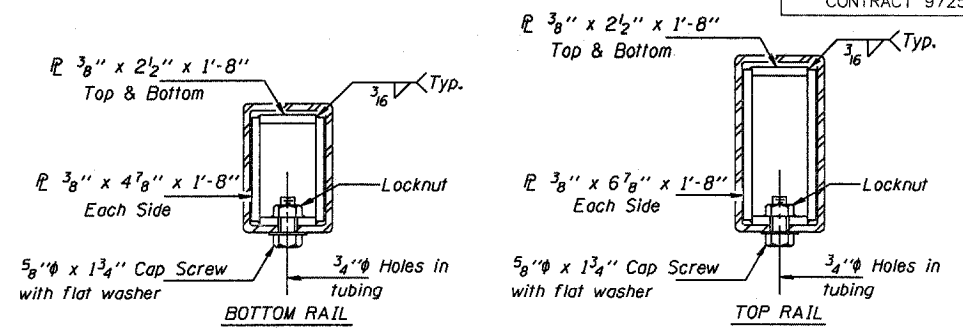

SECTIONS AT RAIL SPLICE

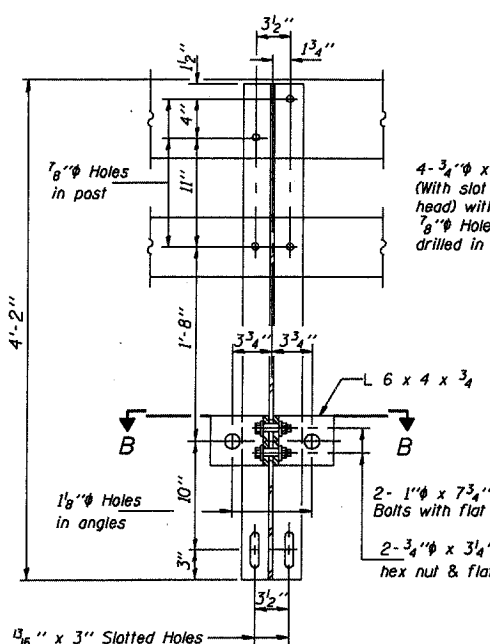

SECTION A-A

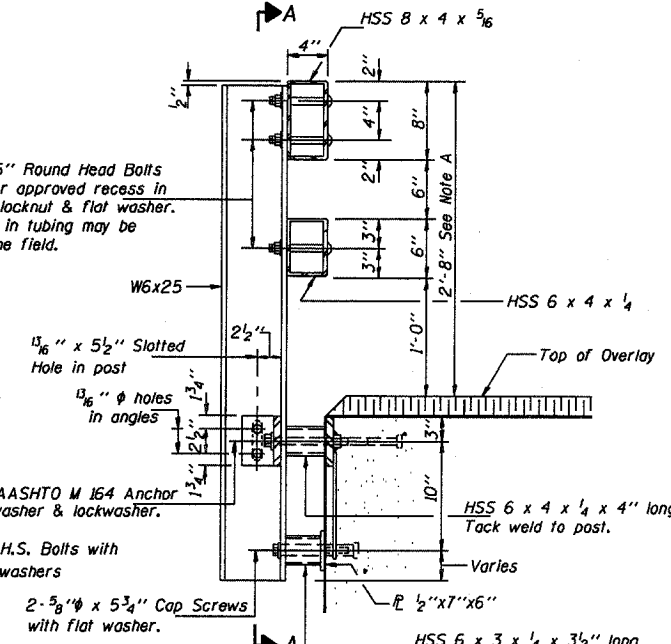

SECTION AT RAIL POST

Note A:
Where no overlay is to be provided, adjust top of rail to lay parallel to grade 2'-10" max. above top of beam

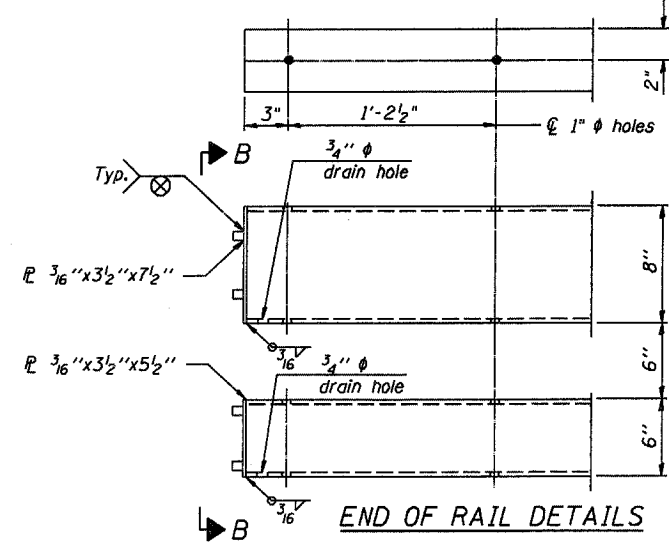

END OF RAIL DETAILS

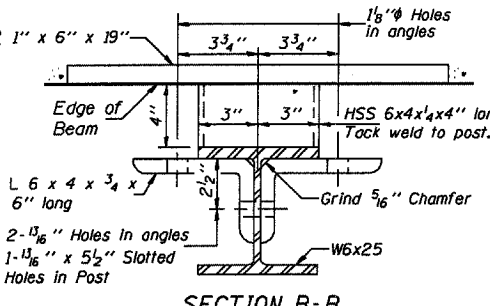

SECTION B-B

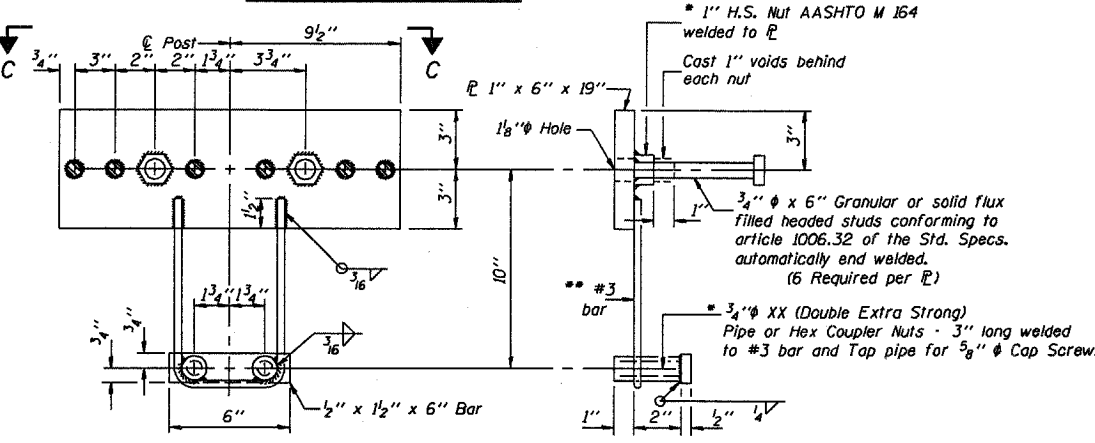

ANCHOR DEVICE

* Threaded areas shall be plugged or blocked off during casting of beam. Galvanized after fabrication.
** Whenever the lower insert assemblies interfere with strand locations, the #3 bars shall be cut and adjusted in order to allow raising or lowering of the lower inserts. Maximum adjustment not to exceed 1/2".

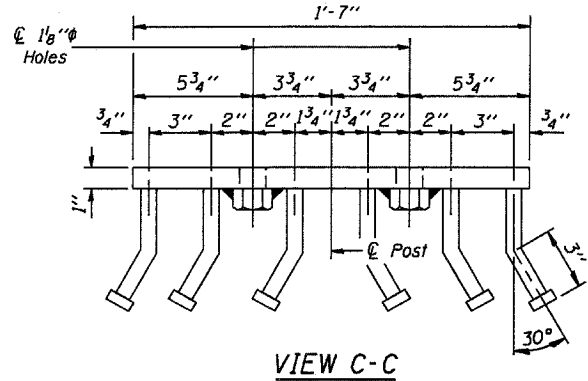

VIEW C-C

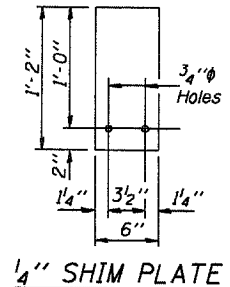

1/4" SHIM PLATE

NOTES

Hollow structural steel tubing shall conform to the requirements of ASTM designation A 500 Grade B Structural Steel Tubing and shall meet the longitudinal CVN requirements of 15 ft-lbs at 0° F.
All other steel shapes and plates shall conform to the requirements of AASHTO M 270 Grade 36 except posts and angles shall conform to AASHTO M 270, Grade 50.
Bolts, cap screws, and nuts shall conform to the requirements of ASTM designation A 307 except for high strength bolts, nuts and washers noted which shall conform to AASHTO M 164.
All bolts, nuts, cap screws, washers and lock washers shall be galvanized according to AASHTO M 232.
All posts, railing, rail splices, anchor devices and angles shall be galvanized after shop fabrication according to AASHTO M 111 and ASTM A 385. Galvanized rail shall not be painted.
Railing shall be according to Section 509 of the Standard Specifications, except as noted, and will be paid for at the contract unit price per foot for STEEL RAILING, TYPE SM.
All field drilled holes shall be coated with an approved zinc rich paint before erection.
For multi-span bridges, sufficient 1/4" x 6" x 1'-2" galvanized steel shims shall be provided to align rail between adjacent spans. Cost included with STEEL BRIDGE RAIL, TYPE SM.
The 1/2" x 7" x 6" plates that come in contact with concrete shall receive two coats of asphalt paint conforming to Section 1060.07 Type II or place 1/8" fabric bearing pads between the plates and concrete.
The 3/4" high strength bolts used to connect the 6 x 4 x 3/4 angles to the post shall be tightened according to Article 505.04(f)(2) of the Standard Specifications. The 1" high strength bolts connecting the angles to the concrete shall be tightened to a snug fit and given an additional 1/8 turn. The 5/8" cap screws in bottom of posts shall be tightened to a snug fit only.
The Maximum allowable rail post spacing shall be 6'-3".

Illinois Department of Transportation
 PASSED APRIL 4, 2005
 Thomas J. Romagnolo
 Engineer of Design
 APPROVED APRIL 4, 2005
 Ralph E. Anderson
 Engineer of Bridges and Structures

STEEL BRIDGE RAIL, TYPE SM
 STANDARD CR-TSM

Reinforcement cage shall be omitted when Concrete Encasement is provided.

The cost of Reinforcement is included with the Cost of Furnishing Piles.

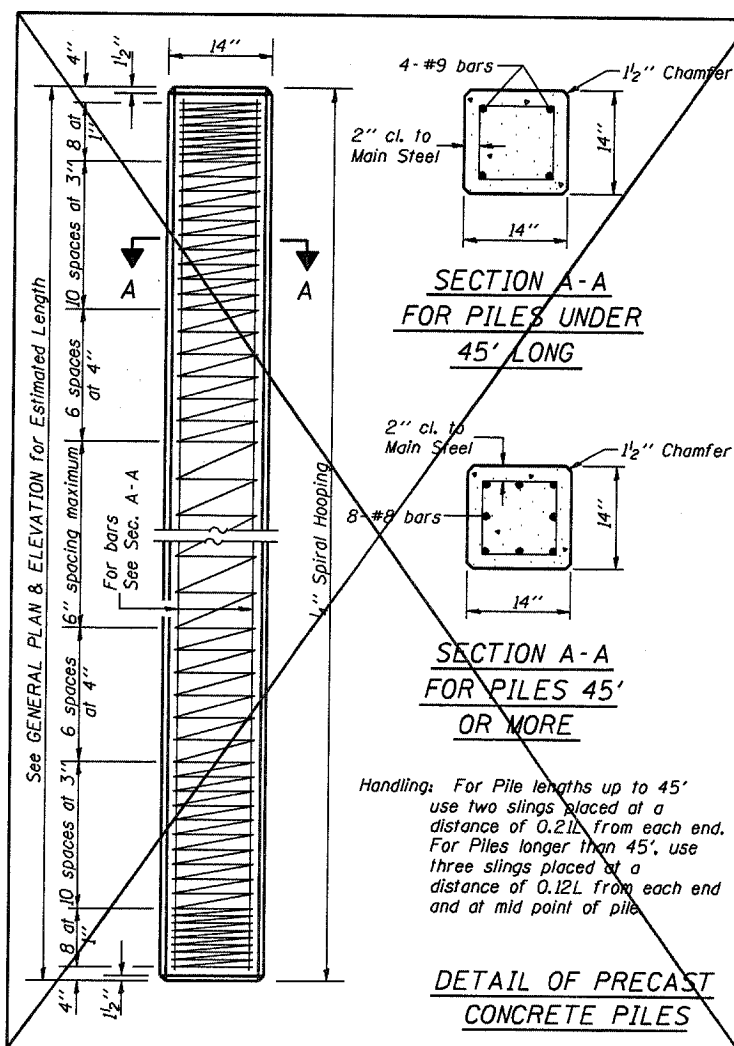

DETAIL OF PRECAST CONCRETE PILES

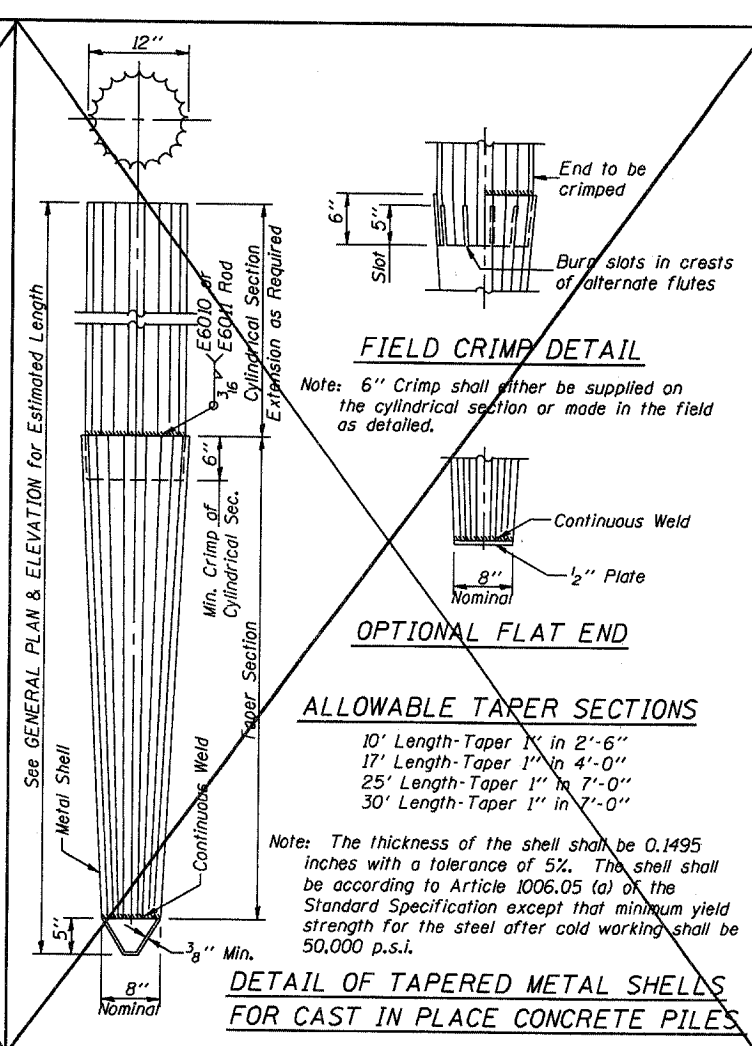

DETAIL OF TAPERED METAL SHELLS FOR CAST IN PLACE CONCRETE PILES

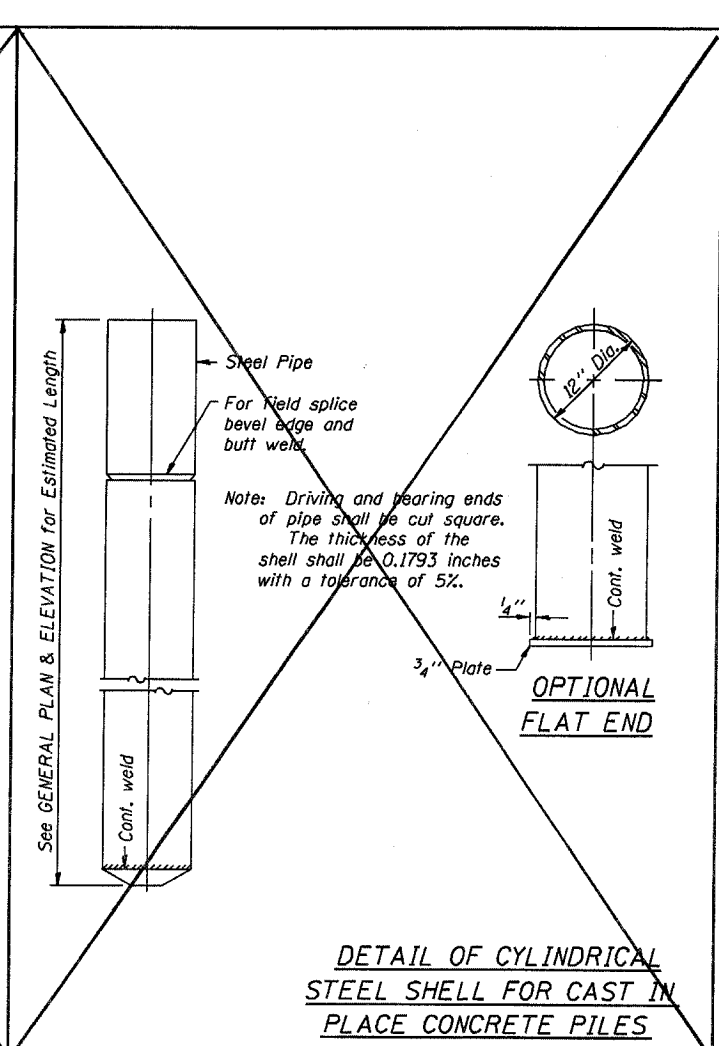

DETAIL OF CYLINDRICAL STEEL SHELL FOR CAST IN PLACE CONCRETE PILES

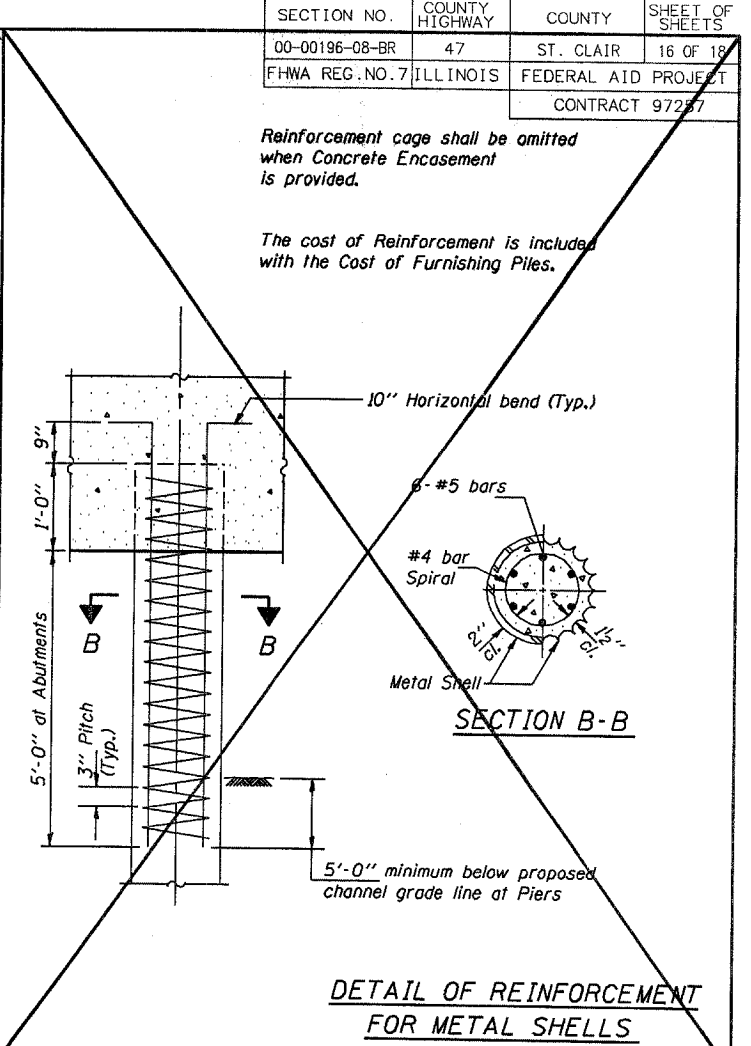

DETAIL OF REINFORCEMENT FOR METAL SHELLS

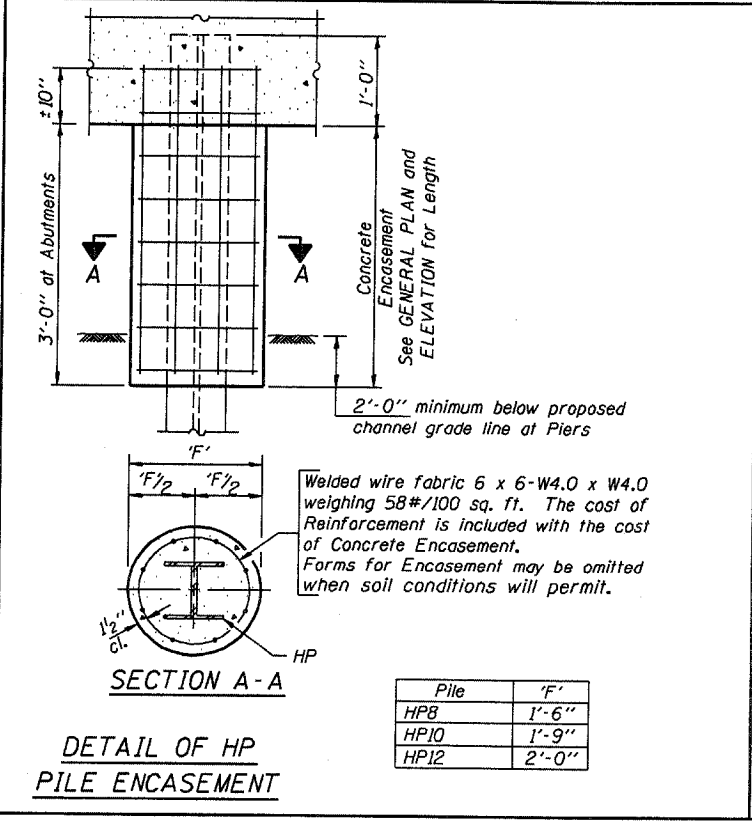

Pile	'F'
HP8	1'-6"
HP10	1'-9"
HP12	2'-0"

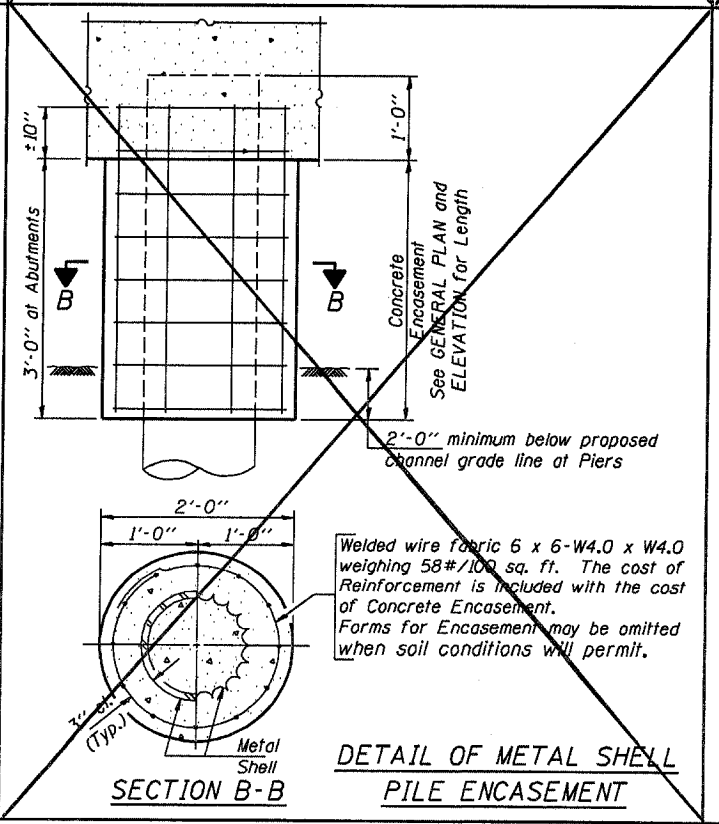

QUANTITIES/FT. OF ENCASEMENT (STEEL PILES)

Pile Size	Item	Quantity
HP8	Concrete Encasement	0.063 C.Y.
HP10	Concrete Encasement	0.086 C.Y.
HP12	Concrete Encasement	0.112 C.Y.

(METAL SHELL PILES)

Pile Size	Item	Quantity
12" Dia.	Concrete Encasement	0.087 C.Y.

Illinois Department of Transportation
 PASSED FEBRUARY 1, 2000
 (Theresa Demagala)
 Engineer of Bridge Design
 APPROVED FEBRUARY 1, 2000
 (Ralph E. Anderson)
 Engineer of Bridges and Structures

PILE DETAILS

STANDARD CX-1

SECTION NO.	COUNTY HIGHWAY	COUNTY	SHEET OF SHEETS
00-00196-08-BR	47	ST. CLAIR	17 OF 18
FHWA REG. NO. x	ILLINOIS	FEDERAL AID PROJECT	
	XSEC	CONTRACT 97257	

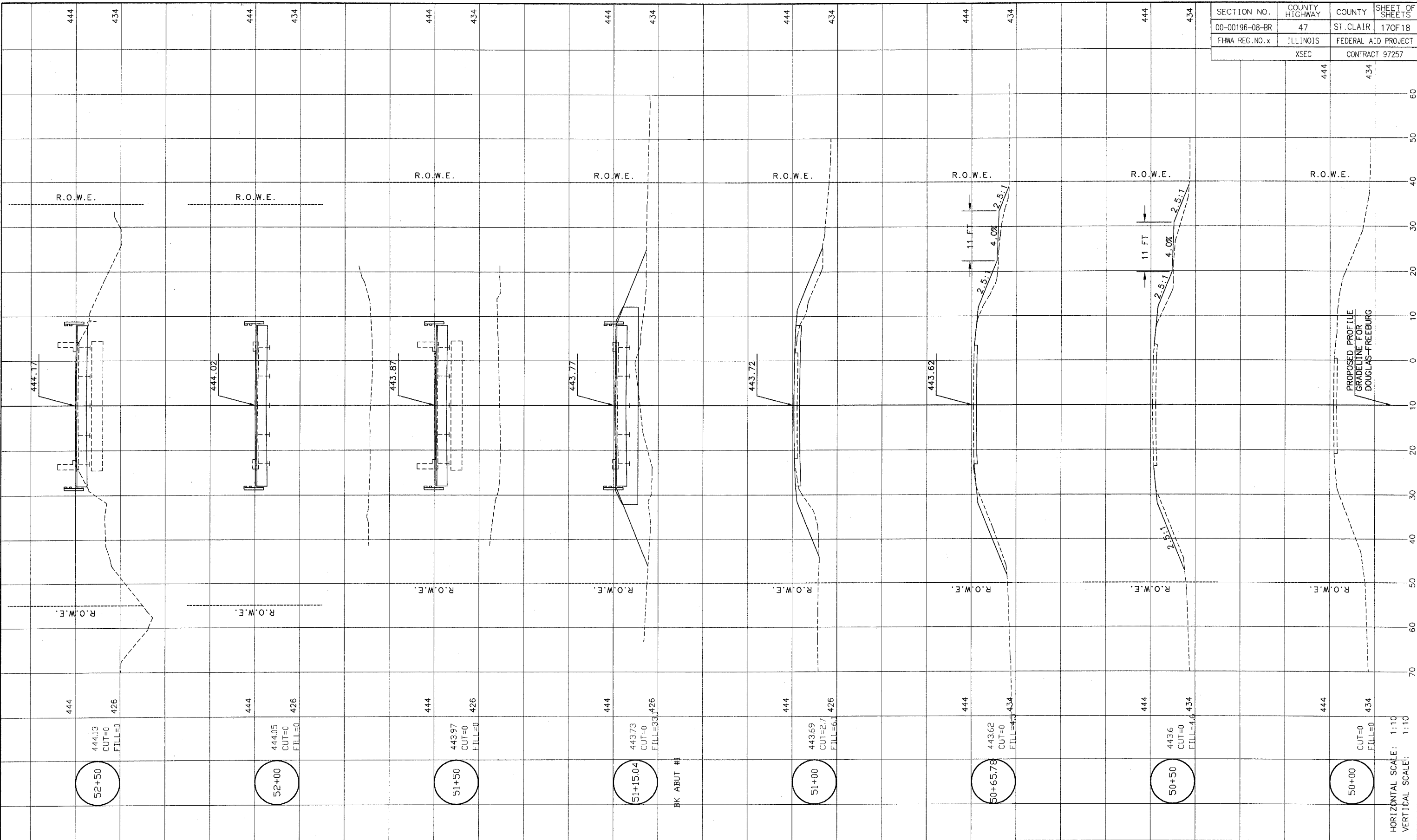

HORIZONTAL SCALE: 1:10
 VERTICAL SCALE: 1:10

SECTION NO.	COUNTY HIGHWAY	COUNTY	SHEET OF SHEETS
00-00196-08-BR	47	ST. CLAIR	18 OF 18
FHWA REG. NO. x	ILLINOIS	FEDERAL AID PROJECT	
	XSEC	CONTRACT 97257	

444
434

444
434

444
434

444
434

70

60

50

40

30

20

10

0

10

20

30

40

50

60

444
434

444.56
CUT=0
FILL=0.4

53+50

444
434

444.34
CUT=0
FILL=1.3

53+05.78

444
434

444.31
CUT=0.8
FILL=2.3

53+00

444
434

444.11
CUT=4.6
FILL=11

52+56.54

BK ABUT #2

HORIZONTAL SCALE: 1:10
VERTICAL SCALE: 1:10

