

STATE OF ILLINOIS
DEPARTMENT OF TRANSPORTATION

F.A.I. RTE.	SECTION	COUNTY	TOTAL SHEETS	SHEET NO.
74	MBPM 2023-1	DEWITT	28	1
		ILLINOIS	CONTRACT NO. 70G28	

FOR INDEX OF SHEETS, SEE SHEET NO. 2

PROPOSED HIGHWAY PLANS

FAI ROUTE 74 (I-74)
SECTION MBPM 2023-1
PROJECT NHPP-PQCZ(886)
BRIDGE JOINT REPLACE /
REPAIR MISCELLANEOUS
DEWITT COUNTY

C-95-016-23

**CURRENT
TRAFFIC DATA**
MCLEAN CO. LINE TO IL 54
2021 ADT: 22,900
2031 ADT: 29,800
PU + PC% = 66
SU% = 4
MU% = 29

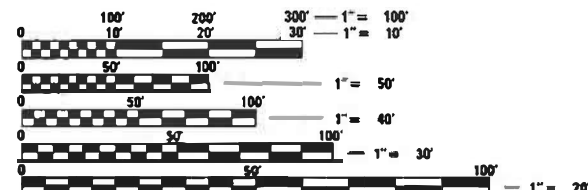
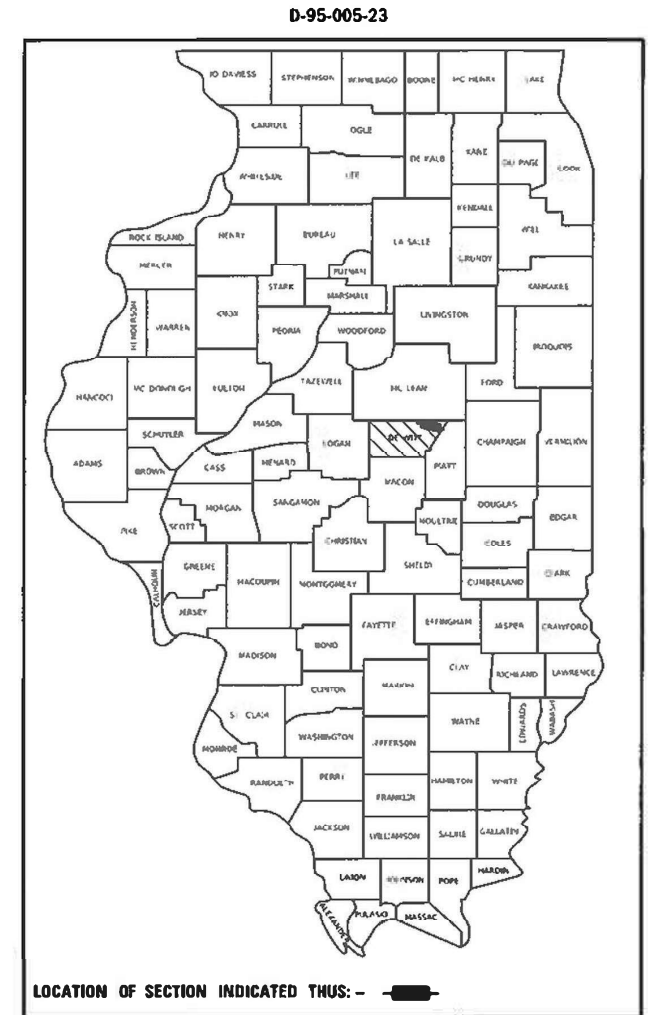

FULL SIZE PLANS HAVE BEEN PREPARED USING STANDARD ENGINEERING SCALES. REDUCED SIZED PLANS WILL NOT CONFORM TO STANDARD SCALES. IN MAKING MEASUREMENTS ON REDUCED PLANS, THE ABOVE SCALES MAY BE USED.

J.U.L.I.E.
JOINT UTILITY LOCATION INFORMATION FOR EXCAVATORS
1-800-892-0123
OR 811

TOWNSHIP: SANTA ANNA

PROJECT ENGINEER: TIM BRANDENBURG
PROJECT MANAGER: ERIC SHAWLER
PHONE NUMBER: (217)465-4181

CONTRACT NO. 70G28

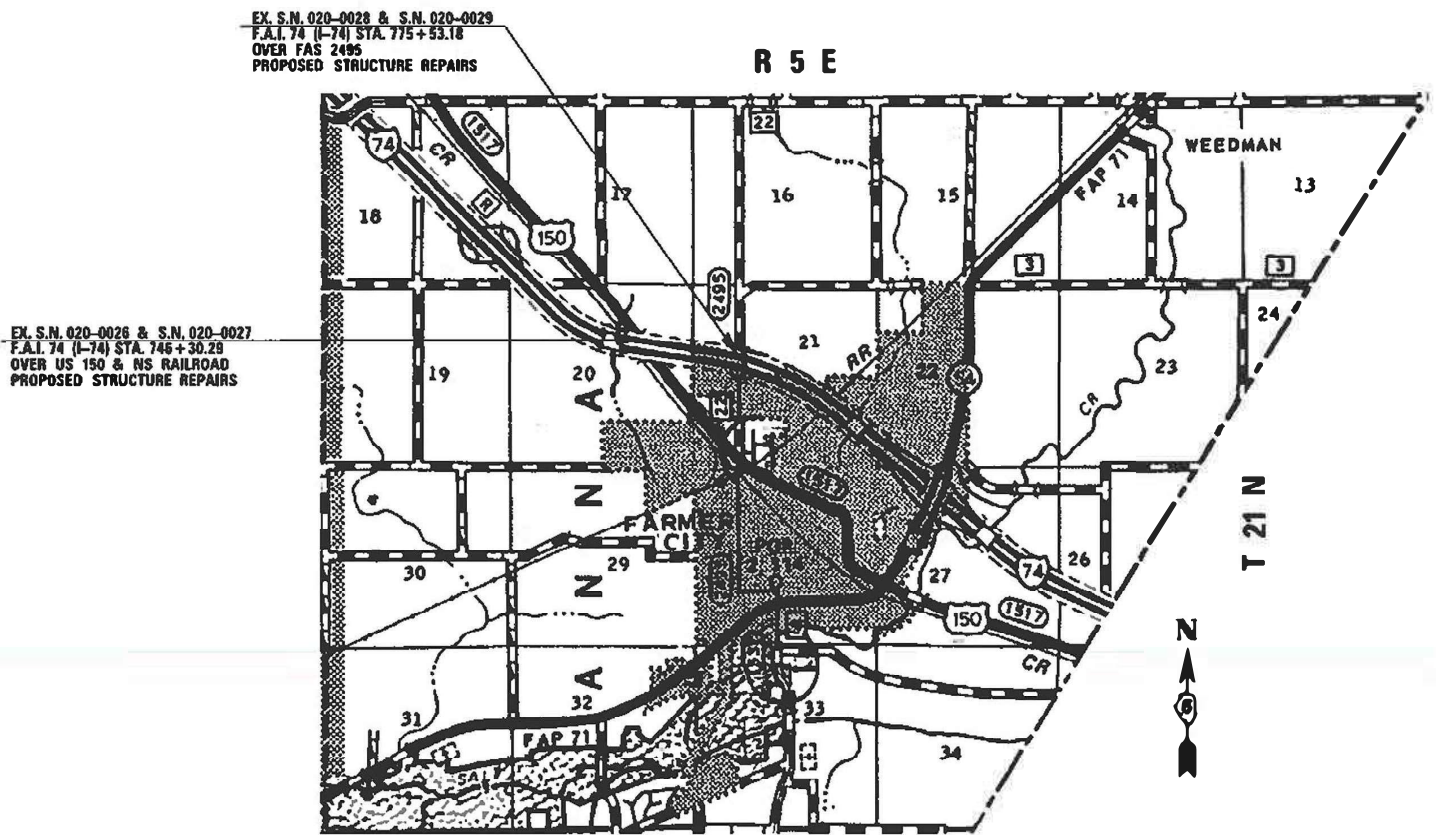

STATE OF ILLINOIS
DEPARTMENT OF TRANSPORTATION

SUBMITTED 11/29/2022
Kensil A. Barnett
REGIONAL ENGINEER

February 3, 2023
[Signature]
ENGINEER OF DESIGN AND ENVIRONMENT

February 3, 2023
[Signature]
DIRECTOR OF HIGHWAYS PROJECT IMPLEMENTATION

PRINTED BY THE AUTHORITY
OF THE STATE OF ILLINOIS

MODEL: \\MODEL\MAMFS
 FILE: \\MAILS_PUB\Public\paw_bentley.com\FW\DOT\Documents\DOT_Offices\District_5\Project\0570228\CAD\Drawings\0570228-11-500.dgn

CODE NO.	ITEM	UNIT	TOTAL QUANTITY	DEWITT CO.	DEWITT CO.
				FAI 74 (I-74)	FAI 74 (I-74)
				RURAL / INTERSTATE	RURAL / INTERSTATE
				BRIDGE DECK REPAIR	BRIDGE DECK REPAIR
				S.N. 020-0026 & 0027	S.N. 020-0028 & 0029
				90% FED / 10% STATE	90% FED / 10% STATE
				0047	0047
				QUANTITY	QUANTITY
50102400	CONCRETE REMOVAL	CU YD	6.6	6.6	0.0
50300255	CONCRETE SUPERSTRUCTURE	CU YD	6.2	6.2	0.0
50800205	REINFORCEMENT BARS, EPOXY COATED	POUND	720.0	720.0	0.0
50800515	BAR SPLICERS	EACH	8.0	8.0	0.0
52000110	PREFORMED JOINT STRIP SEAL	FOOT	123.0	123.0	0.0
67000400	ENGINEER'S FIELD OFFICE, TYPE A	CAL MO	3.0	1.5	1.5
67100100	MOBILIZATION	L SUM	1.0	0.5	0.5
70100207	TRAFFIC CONTROL AND PROTECTION, STANDARD 701402	EACH	2.0	2.0	0.0
70100800	TRAFFIC CONTROL AND PROTECTION, STANDARD 701401	L SUM	1.0	0.5	0.5
70107025	CHANGEABLE MESSAGE SIGN	CAL DA	28.0	14.0	14.0
70400100	TEMPORARY CONCRETE BARRIER	FOOT	1,850.0	1,850.0	0.0
70400200	RELOCATE TEMPORARY CONCRETE BARRIER	FOOT	1,850.0	1,850.0	0.0
70600250	IMPACT ATTENUATORS, TEMPORARY (NON- REDIRECTIVE), TEST LEVEL 3	EACH	2.0	2.0	0.0
70600350	IMPACT ATTENUATORS, RELOCATE (NON- REDIRECTIVE), TEST LEVEL 3	EACH	2.0	2.0	0.0

* SPECIALTY ITEM

USER NAME = erik.shawler	DESIGNED -	REVISED -
	DRAWN -	REVISED -
PLOT SCALE = 40,0000 * / in.	CHECKED -	REVISED -
PLOT DATE = 11/30/2022	DATE -	REVISED -

STATE OF ILLINOIS
DEPARTMENT OF TRANSPORTATION

SUMMARY OF QUANTITIES
S.N. 020-0026 S.N. 020-0027 S.N. 020-0028 S.N. 020-0029

SCALE: SHEET 1 OF 2 SHEETS STA. TO STA.

F.A.I. RTE.	SECTION	COUNTY	TOTAL SHEETS	SHEET NO.
74	MBPM 2023-1	DE WITT	28	3
CONTRACT NO. 70G28			ILLINOIS FED. AID PROJECT	

MODEL: \\MODELS\NAME\$
FILE: \\MODELS\PROJECTS\DOT_Offices\District_5\Projects\020278\CAD\Drawings\CAD\Sheets\020278-48-100.dgn

CODE NO.	ITEM	UNIT	TOTAL QUANTITY	DEWITT CO.	DEWITT CO.
				FAI 74 (I-74)	FAI 74 (I-74)
				RURAL / INTERSTATE	RURAL / INTERSTATE
				BRIDGE DECK REPAIR	BRIDGE DECK REPAIR
				S.N. 020-0026 & 0027	S.N. 020-0028 & 0029
				90% FED / 10% STATE	90% FED / 10% STATE
				0047	0047
				QUANTITY	QUANTITY
* 78008330	POLYUREA PAVEMENT MARKING TYPE II - LINE 6"	FOOT	3,820.0	2,940.0	880.0
* 78011035	GROOVING FOR RECESSED PAVEMENT MARKING 7"	FOOT	3,820.0	2,940.0	880.0
78300202	PAVEMENT MARKING REMOVAL - WATER BLASTING	SQ FT	1,505.0	1,065.0	440.0
X1000002	HIGH FRICTION SURFACE TREATMENT FOR BRIDGE DECK SURFACES	SQ YD	4,958.0	3,644.0	1,314.0
X2700001	TEMPORARY RUMBLE STRIPS (SPECIAL)	EACH	16.0	8.0	8.0
X4510050	HIGH FRICTION SURFACE TREATMENT CRACK FILLING	FOOT	2,000.0	1,200.0	800.0
X7200201	WIDTH RESTRICTION SIGNING	L SUM	1.0	1.0	0.0
Z0001800	APPROACH SLAB REPAIR (PARTIAL DEPTH)	SQ YD	11.0	6.0	5.0
Z0013798	CONSTRUCTION LAYOUT	L SUM	1.0	0.5	0.5
Z0016200	DECK SLAB REPAIR (PARTIAL DEPTH)	SQ YD	42.0	32.0	10.0
Z0029090	DIAMOND GRINDING (BRIDGE SECTION)	SQ YD	4,551.0	3,327.0	1,224.0

* SPECIALTY ITEM

USER NAME = eric.shawler	DESIGNED -	REVISED -
PLOT SCALE = 40.0000' / in.	DRAWN -	REVISED -
PLOT DATE = 11/30/2022	CHECKED -	REVISED -
	DATE -	REVISED -

STATE OF ILLINOIS
DEPARTMENT OF TRANSPORTATION

SUMMARY OF QUANTITIES			
S.N. 020-0026	S.N. 020-0027	S.N. 020-0028	S.N. 020-0029
SCALE:	SHEET 2 OF 2 SHEETS	STA.	TO STA.

F.A.I. RTE.	SECTION	COUNTY	TOTAL SHEETS	SHEET NO.
74	MBPM 2023-1	DE WITT	28	4
			CONTRACT NO. 70G28	
ILLINOIS FED. AID PROJECT				

PAVEMENT MARKING - WATER BLASING - LINE 6"								
								78300202
								PAVEMENT MARKING - REMOVAL WATER BLASING
ITEM	LINE TYPE	LOCATION	FROM STA.	OFFSET	TO STA.	OFFSET	STRIPES	SQ FT
INTERSTATE 74 STRUCTURE 020-0026 (EB)								
LANE LINE	SD	ACROSS STRUCTURE FAI 74	745+20	0	749+90	0	12.0	60.0
LANE LINE	SOLID	ACROSS STRUCTURE FAI 74	745+20	12' RT	749+90	12' RT	NA	235.0
LANE LINE	SOLID	ACROSS STRUCTURE FAI 74	745+20	12' LT	749+90	12' LT	NA	235.0
INTERSTATE 74 STRUCTURE 020-0027 (WB)								
LANE LINE	SD	ACROSS STRUCTURE FAI 74	744+25	0	749+00	0	12.0	60.0
LANE LINE	SOLID	ACROSS STRUCTURE FAI 74	744+25	12' RT	749+00	12' RT	NA	237.5
LANE LINE	SOLID	ACROSS STRUCTURE FAI 74	744+25	12' LT	749+00	12' LT	NA	237.5
INTERSTATE 74 STRUCTURE 020-0028 (EB)								
LANE LINE	SD	ACROSS STRUCTURE FAI 74	774+60	0	776+55	0	10.0	25.0
LANE LINE	SOLID	ACROSS STRUCTURE FAI 74	774+60	12' RT	776+55	12' RT	NA	97.5
LANE LINE	SOLID	ACROSS STRUCTURE FAI 74	774+60	12' LT	776+55	12' LT	NA	97.5
INTERSTATE 74 STRUCTURE 020-0029 (EB)								
LANE LINE	SD	ACROSS STRUCTURE FAI 74	774+49	0	776+44	0	10.0	25.0
LANE LINE	SOLID	ACROSS STRUCTURE FAI 74	774+49	12' RT	776+44	12' RT	NA	97.5
LANE LINE	SOLID	ACROSS STRUCTURE FAI 74	774+49	12' LT	776+44	12' LT	NA	97.5
CONTRACT 70G28 SUB-TOTALS								1505.0
ROUNDED								1505.0

SD - SKIP DASH

PAVEMENT MARKING - LINE 6"										
								78008330	78011035	
								POLYUREA PAVEMENT MARKINGS TYPE II - LINE 6'	GROOVING FOR RECESSED PAVEMENT MARKING 7"	
ITEM	LINE TYPE	LOCATION	FROM STA.	OFFSET	TO STA.	OFFSET	STRIPES	FOOT	FOOT	
INTERSTATE 74 STRUCTURE 020-0026 (EB)										
LANE LINE	SD	ACROSS STRUCTURE FAI 74	744-00	0	750+50	0	16.0	YELLOW	WHITE	
LANE LINE	SOLID	ACROSS STRUCTURE FAI 74	744-00	12' RT	750+50	12' RT	NA		60	
LANE LINE	SOLID	ACROSS STRUCTURE FAI 74	744-00	12' LT	750+50	12' LT	NA	650	650	
INTERSTATE 74 STRUCTURE 020-0027 (WB)										
LANE LINE	SD	ACROSS STRUCTURE FAI 74	743-65	0	750+20	0	17.0		70	
LANE LINE	SOLID	ACROSS STRUCTURE FAI 74	743-65	12' RT	750+20	12' RT	NA	655	655	
LANE LINE	SOLID	ACROSS STRUCTURE FAI 74	743-65	12' LT	750+20	12' LT	NA	655	655	
INTERSTATE 74 STRUCTURE 020-0028 (EB)										
LANE LINE	SD	ACROSS STRUCTURE FAI 74	774-60	0	776+55	0	5.0		50	
LANE LINE	SOLID	ACROSS STRUCTURE FAI 74	774-60	12' RT	776+55	12' RT	NA		95	
LANE LINE	SOLID	ACROSS STRUCTURE FAI 74	774-60	12' LT	776+55	12' LT	NA	195	195	
INTERSTATE 74 STRUCTURE 020-0029 (WB)										
LANE LINE	SD	ACROSS STRUCTURE FAI 74	774-49	0	776+44	0	5.0		50	
LANE LINE	SOLID	ACROSS STRUCTURE FAI 74	774-49	12' RT	776+44	12' RT	NA	195	195	
LANE LINE	SOLID	ACROSS STRUCTURE FAI 74	774-49	12' LT	776+44	12' LT	NA		95	
CONTRACT 70G28 SUB-TOTALS								1695.0	2125.0	3820.0
CONTRACT 70G28 TOTALS								3820.0		3820.0
ROUNDED								3820.0		3820.0

MODEL: \\MODEL\MARF5
 FILE: MARF5_PAVEMENT\PAVEMENT.dwg
 PROJECT: \\PROJECTS\70G28\70G28\DATA\CAD\PROJECTS\70G28\PAVEMENT.dwg

USER NAME = erik.shawler	DESIGNED -	REVISED -
	DRAWN -	REVISED -
PLOT SCALE = 40.0000 * / in.	CHECKED -	REVISED -
PLOT DATE = 11/29/2022	DATE -	REVISED -

STATE OF ILLINOIS
DEPARTMENT OF TRANSPORTATION

SCHEDULES			
S.N. 020-0026 S.N. 0027 S.N. 0028 SN. 0029			
SCALE:	SHEET 1	OF 1 SHEETS	STA. TO STA.

F.A.I. RTE.	SECTION	COUNTY	TOTAL SHEETS	SHEET NO.
74	MBPM 2023-1	DE WITT	28	5
			CONTRACT NO. 70G28	
ILLINOIS FED. AID PROJECT				

**TEMPORARY CONCRETE
BARRIER LAYOUT-STAGE I
S.N. 020-0026 (EB) &
S.N. 020-0027 (WB)**

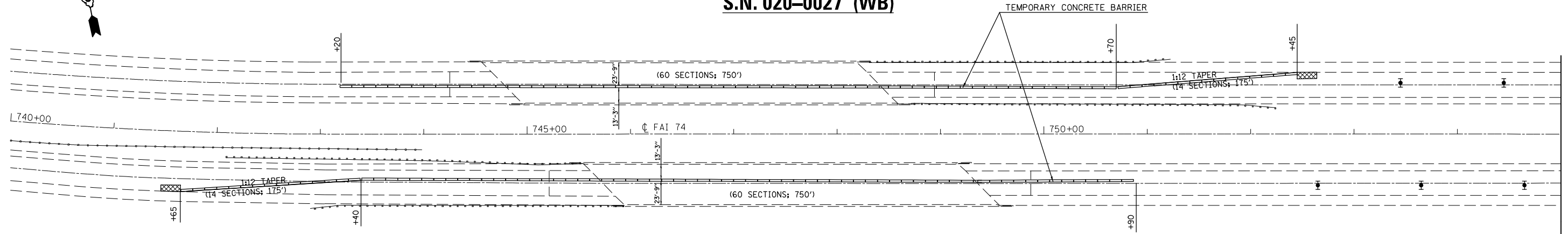

BILL OF MATERIAL

Structure	Item	Unit	Total
020-0026	Temporary Concrete Barrier	Foot	925.0
	Impact Attenuator, Temporary (Non-Redirect), Test Level 3	Each	1.0
020-0027	Temporary Concrete Barrier	Foot	925.0
	Impact Attenuator, Temporary (Non-Redirect), Test Level 3	Each	1.0

IF WORKING ON CONCURRENT STRUCTURES, TYPE II BARRICADES, DRUMS OR VERTICAL BARRICADES WITH STEADY BURN MONODIRECTIONAL LIGHT AT 100' CENTERS SHALL BE USED PER HIGHWAY STANDARD 701402. COST INCLUDED WITH TRAFFIC CONTROL AND PROTECTION STANDARD 701402.

PLAN NOTES:

ALL STAGING DETAILS SHALL BE IN ACCORDANCE WITH TRAFFIC CONTROL AND PROTECTION STANDARDS 701400 AND 701402 AND PAID FOR AT THE CONTRACT UNIT PRICE PER EACH LOCATION.

ALL WORK WITHOUT TEMPORARY CONCRETE BARRIER IN PLACE SHALL BE IN ACCORDANCE WITH TRAFFIC CONTROL AND PROTECTION STANDARDS 701400 AND 701401.

FOR ADDITIONAL DETAILS ASSOCIATED WITH TEMPORARY CONCRETE BARRIER, SEE TRAFFIC CONTROL AND PROTECTION STANDARD 704001.

REFLECTORIZED TEMPORARY MARKING TAPE SHALL BE PLACED THROUGHOUT THE TAPER, AND ALONGSIDE BOTH SIDES OF THE WORK AREA. EXISTING MARKINGS THAT CONFLICT WITH THE STAGED TRAFFIC MARKINGS SHALL BE REMOVED. COST TO REMOVE EXISTING MARKINGS AND FOR THE PLACEMENT AND REMOVAL OF TEMPORARY MARKINGS SHALL BE INCLUDED WITH TRAFFIC CONTROL AND PROTECTION STANDARD 701402.

PORTABLE CHANGEABLE MESSAGE SIGNS ARE REQUIRED SEVEN DAYS PRIOR TO CONSTRUCTION. THE RESIDENT ENGINEER OR TRAFFIC CONTROL SUPERVISOR SHALL PROVIDE AN APPROPRIATE MESSAGE.

SYMBOLS

- TEMPORARY CONCRETE BARRIER
- IMPACT ATTENUATOR

**TEMPORARY CONCRETE
BARRIER LAYOUT-STAGE II
S.N. 020-0026 (EB) &
S.N. 020-0027 (WB)**

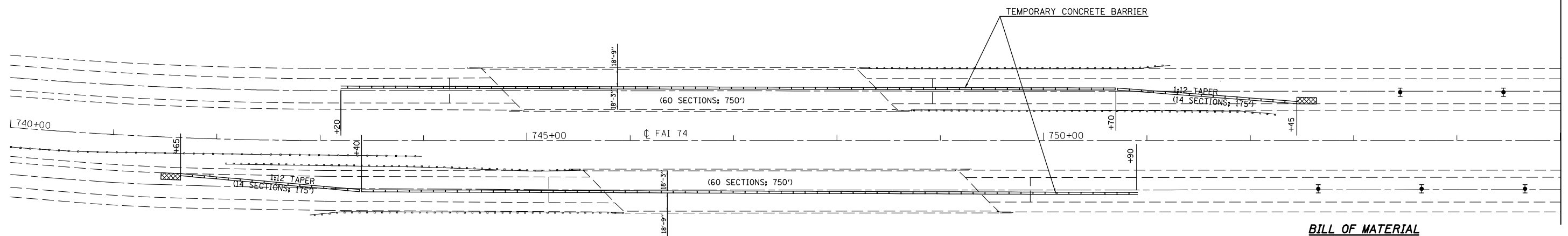

BILL OF MATERIAL

Structure	Item	Unit	Total
020-0026	Relocate Temporary Concrete Barrier	Foot	925.0
	Impact Attenuator, Relocate (Non-Redirect), Test Level 3	Each	1.0
020-0027	Relocate Temporary Concrete Barrier	Foot	925.0
	Impact Attenuator, Relocate (Non-Redirect), Test Level 3	Each	1.0

IF WORKING ON CONCURRENT STRUCTURES, TYPE II BARRICADES, DRUMS OR VERTICAL BARRICADES WITH STEADY BURN MONODIRECTIONAL LIGHT AT 100' CENTERS SHALL BE USED PER HIGHWAY STANDARD 701402. COST INCLUDED WITH TRAFFIC CONTROL AND PROTECTION STANDARD 701402.

**STATE OF ILLINOIS
DEPARTMENT OF TRANSPORTATION**

**TEMPORARY CONCRETE BARRIER LAYOUT
S.N. 020-0026 (EB) & S.N. 020-0027 (WB)**

SCALE: SHEET 1 OF 1 SHEETS STA. TO STA.

F.A.I. RTE.	SECTION	COUNTY	TOTAL SHEETS	SHEET NO.
74	MBPM 2023-1	DE WITT	28	6
CONTRACT NO. 70G28				
ILLINOIS FED. AID PROJECT				

USER NAME = erik.shawler	DESIGNED -	REVISED -
PLOT SCALE = 100,0000' / in.	DRAWN -	REVISED -
PLOT DATE = 11/29/2022	CHECKED -	REVISED -
	DATE -	REVISED -

MODEL: \\MODEL\MKMF5
FILE: \\MAILS_P\pub\lucy_beaufay.com\FW\DOT\Documents\DOT Office\Dir\Dir: S\Project\05702628\CADD\DATA\CAD\Sheet\05702628-pl-1-stage1.dgn

The existing structures were built in 1970 as Route FAI-74, Section 20-1HVB at Sta. 746+30.29 in DeWitt County. The structures carry I-74 over US 150 and Norfolk Southern Railway Company northwest of Farmer City. In 1975 a waterproofing membrane and HMA wearing surface was placed under Section D5 Bridge Deck Waterproofing 1975-3, Contract 29686. In 2004 the HMA wearing surface was removed and replaced with Section 74(3RS-2, 4-1-RS-1), Contract 70027.

The superstructure consists of seven 44" steel plate girders supporting a 7½" R.C. deck and 1¾" HMA wearing surface with waterproofing membrane system. The substructure consists of concrete pile supported stub abutments and timber pile supported piers. The structures measure 366'-8" bk. to bk. abutments and 42'-6" out to out of deck. The horizontal clearance is 40'-6" from face to face of parapet. The spans measure 66'-0", 87'-2", 122'-3", and 84'-2".

GENERAL PLAN & ELEVATION

S.N. 020-0026 (EB) & S.N. 020-0027 (WB)

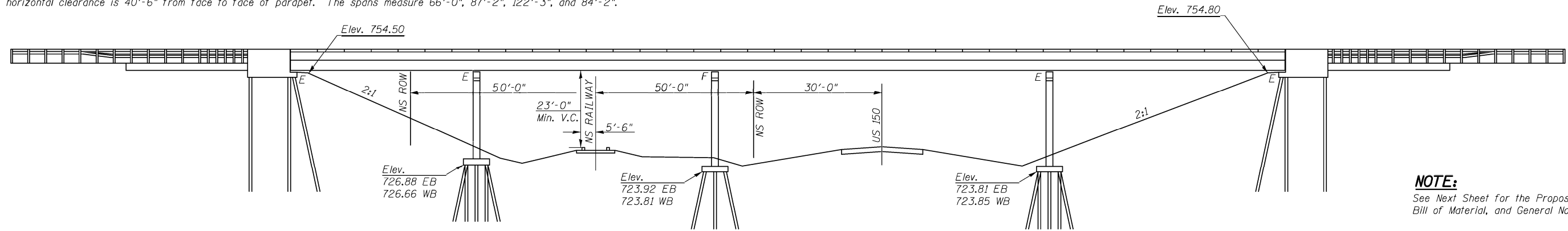

NOTE:
See Next Sheet for the Proposed Work, Bill of Material, and General Notes.

Elevations taken from as-built plans and are shown for perspective only.

ELEVATION VIEW

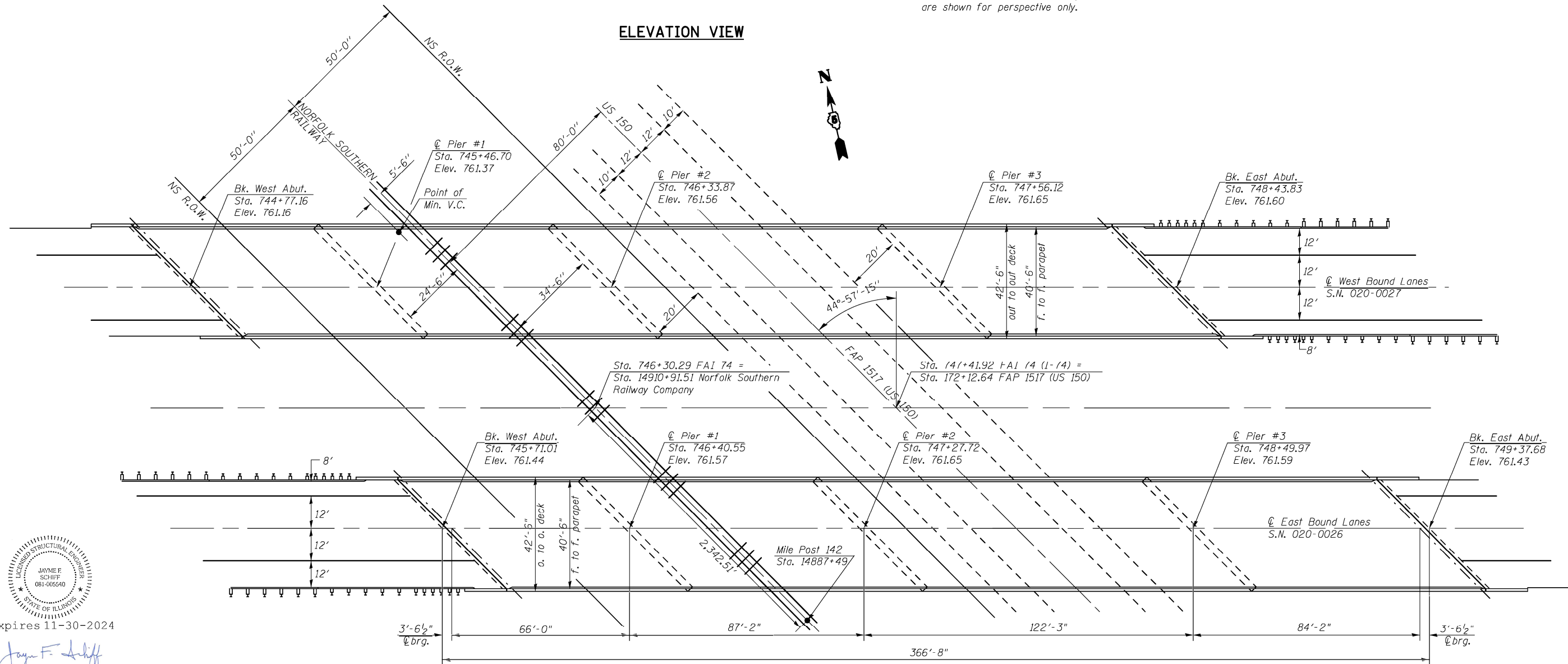

PLAN VIEW

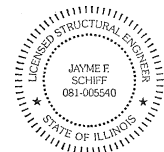

Expires 11-30-2024

Jayme F. Schuff

STATE OF ILLINOIS
DEPARTMENT OF TRANSPORTATION

GENERAL PLAN & ELEVATION
S.N. 020-0026 (EB) S.N. 020-0027 (WB)

SCALE: SHEET 1 OF 12 SHEETS STA. TO STA.

F.A.I. RTE.	SECTION	COUNTY	TOTAL SHEETS	SHEET NO.
74	MBPM 2023-1	DE WITT	28	7
CONTRACT NO. 70G28			ILLINOIS FED. AID PROJECT	

MODEL: 4\MODEL\NAME5
 FILE: NAME5_PlanView.dwg
 Project: S:\Projects\05702628\CAD\Sheet\05702628.dwg
 Date: 11/29/2022
 User: eric.shawler

PROPOSED WORK

1. Removal of Hatch Block.
2. Removal of Existing Joint in the Hatch Block.
3. Perform Partial Depth Patching in Approach and Bridge Deck.
4. Place Reinforcement Bars, Locking Edge Rail in Hatch Block.
5. Pour Deck Hatch Block.
6. Insert Rubber Strip Seal into Locking Edge Rails.
7. Pour Parapet Ends.
8. Diamond Grind Bridge Deck and Approach Slabs at a depth of 1/8".
9. Place High Friction Surface Treatment Crack Filling on Bridge Deck Slab and Approach Slabs.
10. Place High Friction Surface Treatment on Bridge Deck Slab and Approach Slabs.

TOTAL BILL OF MATERIAL

ITEM	UNIT	TOTAL
CONCRETE REMOVAL	CU YD	6.6
CONCRETE SUPERSTRUCTURE	CU YD	6.2
REINFORCEMENT BARS, (EPOXY COATED)	POUND	720.0
BAR SPLICERS	FEET	8.0
PREFORMED JOINT STRIP SEAL	EACH	123.0
HIGH FRICTION SURFACE TREATMENT FOR BRIDGE DECK SURFACES	SQ YD	3,644.0
HIGH FRICTION SURFACE TREATMENT CRACK FILLING	FOOT	1,200.0
APPROACH SLAB REPAIR (PARTIAL DEPTH)	SQ YD	6.0
DECK SLAB REPAIR (PARTIAL DEPTH)	SQ YD	32.0
DIAMOND GRINDING (BRIDGE SECTION)	SQ YD	3,327.0

GENERAL NOTES

The deck hatch blocks shall have its final surface tined according to Article 420.09 (e) (1) of the Standard Specifications. Cost to be included with concrete superstructure.

Plan dimensions and details relative to the existing structure have been taken from existing plans and are subject to nominal construction variations. It shall be the Contractor's responsibility to verify such dimensions and details in the field and make the necessary approved adjustments prior to construction or ordering of materials. Such variations shall not be cause for additional compensation for a change in the scope of work. However, the Contractor will be paid for the quantity actually furnished at the unit price for the work.

Existing reinforcement bars extending into the removal area shall be cleaned, straightened and incorporated into the new construction. Any reinforcement bars that are damaged during concrete removal shall be replaced with an approved bar splicer or anchorage system. Cost included with Concrete Removal.

Joint openings shall be adjusted according to article 520.04 of the Std. Specs. when the deck is poured at an ambient temperature other than 50° F.

Reinforcement bars designated (E) shall be epoxy coated.

Existing Pavement Markings and Raised Reflective Pavement Markers shall be Temporarily Covered Prior to Applications of the Deck Surface Treatment to Prevent the Material from Being Applied to the Markings and Markers. The Temporary Covering shall be Removed After Application of the Deck Surface Treatment and Prior to Opening to Traffic Cost is Included with the Deck Surface Treatment Specified.

MODEL: s:\MODEL\MHFS
 FILE: MHFS_Plan\Bids\Draw\beville.com\PN\DOT\Documents\DOT Offices\District: 5\Projects\05702628\CAD\data\CAD\sheets\05702628\sh-1r-020-000\660027.dgn

USER NAME = eric.shawler	DESIGNED -	REVISED -
	DRAWN -	REVISED -
PLOT SCALE = 40.0000' / in.	CHECKED -	REVISED -
PLOT DATE = 1/17/2023	DATE -	REVISED -

**STATE OF ILLINOIS
DEPARTMENT OF TRANSPORTATION**

**BILL OF MATERIALS & GENERAL NOTES
S.N. 020-0026 (EB) S.N. 020-0027 (WB)**

SCALE: SHEET 2 OF 12 SHEETS STA. TO STA.

F.A.I. RTE.	SECTION	COUNTY	TOTAL SHEETS	SHEET NO.
74	MBPM 2023-1	DE WITT	28	8
			CONTRACT NO. 70G28	
ILLINOIS FED. AID PROJECT				

EXISTING CROSS SECTION

S.N. 020-0026 (EB) & S.N. 020-0027 (WB)

Looking East on East Bound Structure
Looking West on West Bound Structure

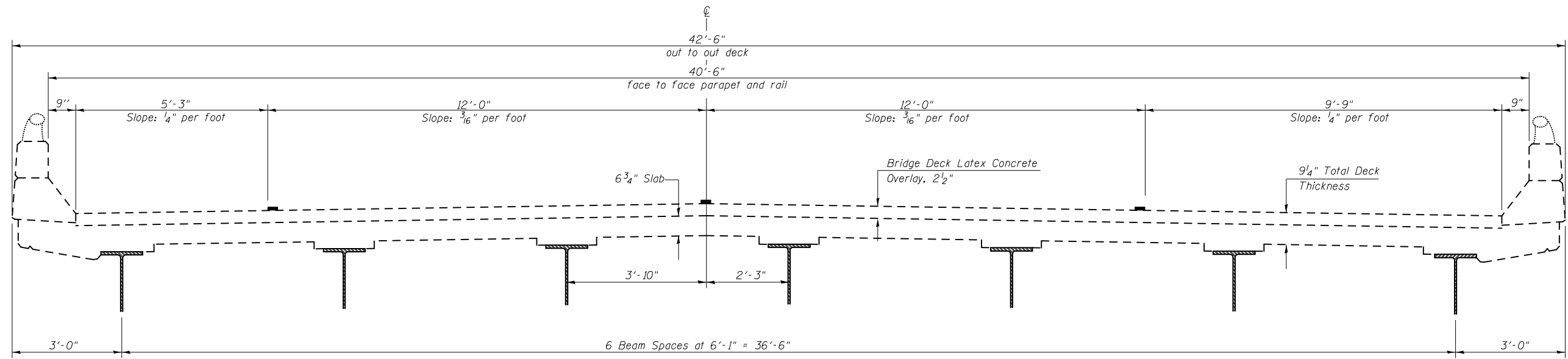

PROPOSED CROSS SECTION

S.N. 020-0026 (EB) & S.N. 020-0027 (WB)

Looking East on East Bound Structure
Looking West on West Bound Structure

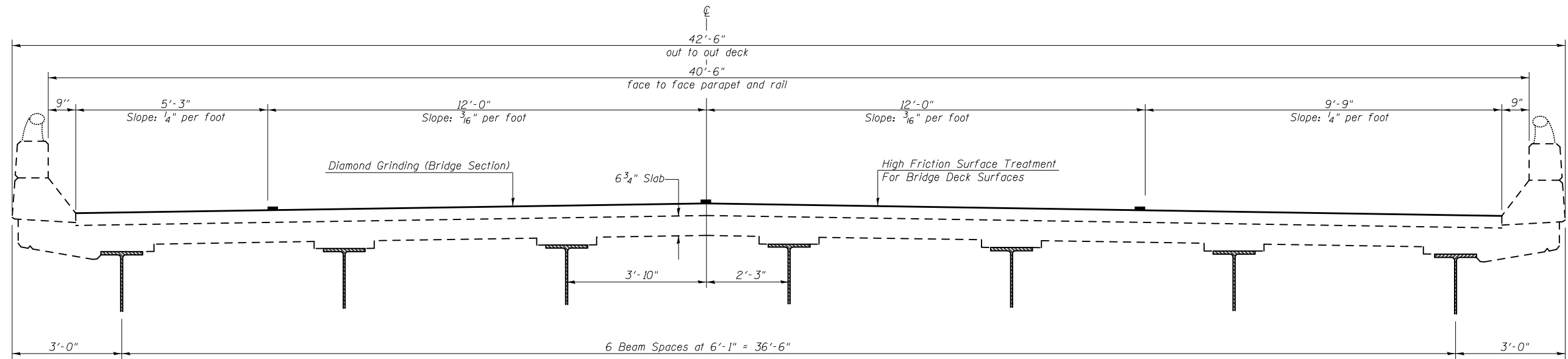

MODEL: \\MODEL\MAME FILE: \\MAILS_P\pub\cpx-bead\p\p\DOT Documents\DOT Office\Dir\dir: S:\Project\05702628\CADD\Drawings\Sheet\05702628-EB-WB-1-020-000-66-0027.dgn

USER NAME = erik.shawler	DESIGNED -	REVISED -
	DRAWN -	REVISED -
PLOT SCALE = 40,0000 * / in.	CHECKED -	REVISED -
PLOT DATE = 1/17/2023	DATE -	REVISED -

**STATE OF ILLINOIS
DEPARTMENT OF TRANSPORTATION**

DECK CROSS SECTIONS			
S.N. 020-0026 (EB) S.N. 020-0027 (WB)			
SCALE:	SHEET 3	OF 12 SHEETS	STA. TO STA.

F.A.I. RTE.	SECTION	COUNTY	TOTAL SHEETS	SHEET NO.
74	MBPM 2023-1	DE WITT	28	9
			CONTRACT NO. 70G28	
ILLINOIS FED. AID PROJECT				

STAGE I CONSTRUCTION DETAILS

S.N. 020-0026 (EB) & S.N. 020-0027 (WB)

Looking East on East Bound Structure
Looking West on West Bound Structure

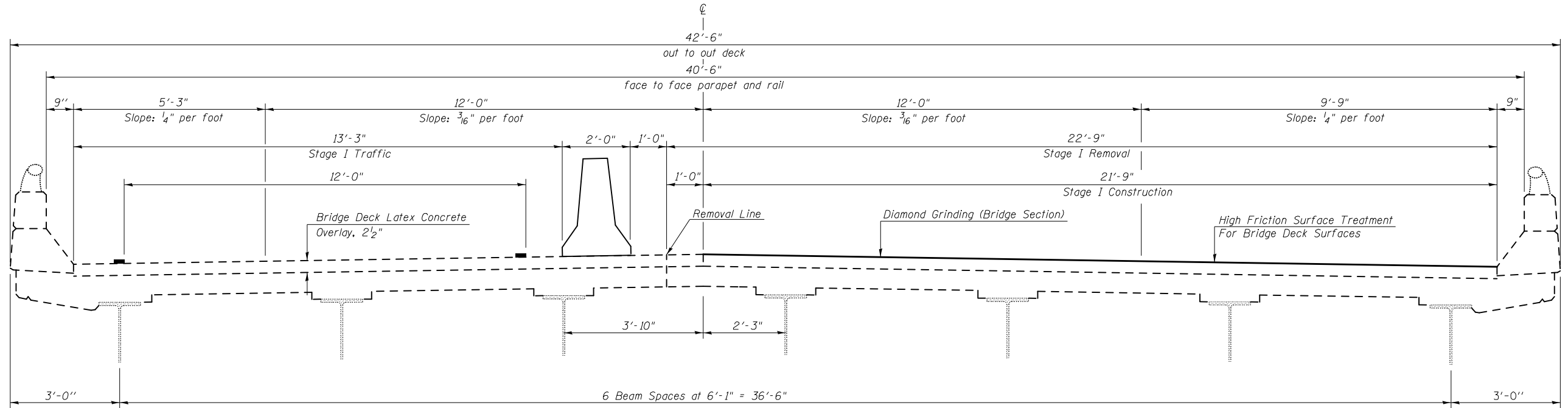

STAGE II CONSTRUCTION DETAILS

S.N. 020-0026 (EB) & S.N. 020-0027 (WB)

Looking East on East Bound Structure
Looking West on West Bound Structure

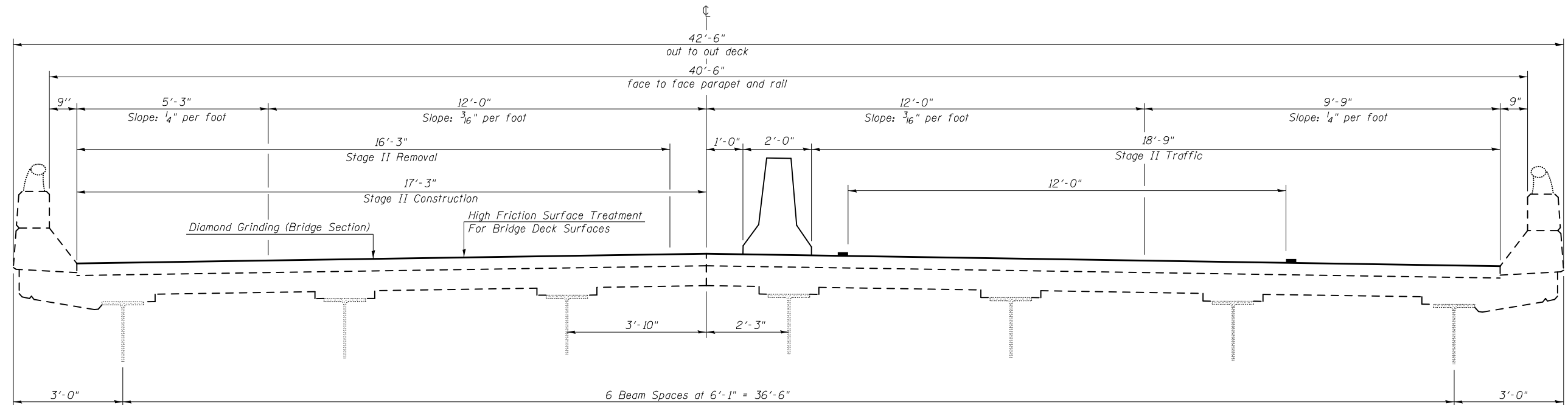

MODEL: \\MODEL\MNMF5
FILE: \\MAILS_P\pub\cshawler\com\PIV\DOT\Documents\DOT_Offices\Dir\trc_5\Project\05702628\CAD\Sheet\05702628-EB-1-1-020-0026-0027.dgn

USER NAME = erik.shawler	DESIGNED -	REVISED -
	DRAWN -	REVISED -
PLOT SCALE = 40,0000 * / in.	CHECKED -	REVISED -
PLOT DATE = 11/29/2022	DATE -	REVISED -

**STATE OF ILLINOIS
DEPARTMENT OF TRANSPORTATION**

STAGING DECK CROSS SECTIONS
S.N. 020-0026 (EB) S.N. 020-0027 (WB)

SCALE: SHEET 4 OF 12 SHEETS STA. TO STA.

F.A.I. RTE.	SECTION	COUNTY	TOTAL SHEETS	SHEET NO.
74	MBPM 2023-1	DE WITT	28	10
CONTRACT NO. 70G28				
ILLINOIS FED. AID PROJECT				

WEARING SURFACE PLAN

S.N. 020-0026 (EB) & S.N. 020-0027 (WB)

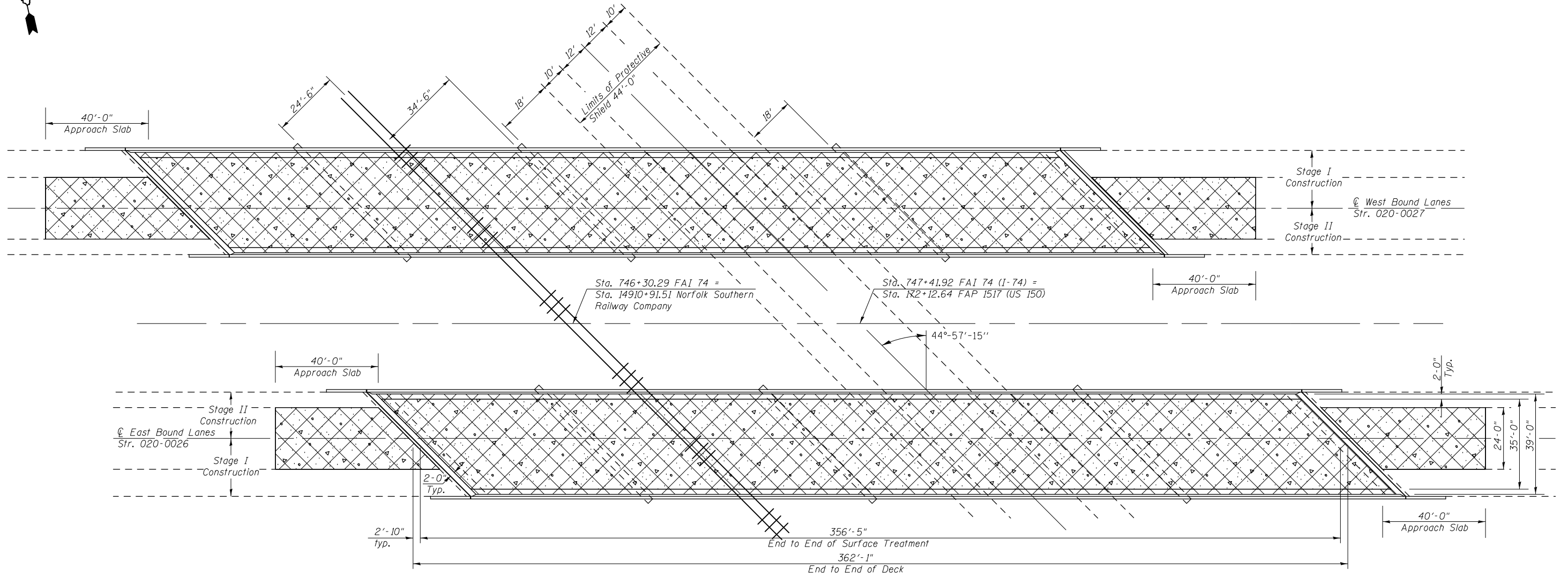

NOTES:

Diamond Grinding (Bridge Section) and High Friction Surface Treatment For Deck Surface Will Not Be Applied to the 1'-0" Hatch Block or the 2'-0" Deck Surface.

Deck Drains and Joints Shall Be Temporary Covered Before the High Friction Surface Treatment is Applied To Protect and Cover Run Off. The Material Used to Cover the Drains and Joints Shall Be Removed and Disposed of Upon the Completion of the High Friction Surface Treatment. Cost Included with High Friction Surface Treatment.

Placement of the Overlapping High Friction Surface Treatment Joint Will Not Be Allowed at the Wheel Lanes.

- Diamond Grinding (Bridge Section)
- High Friction Surface Treatment For Deck Surfaces

BILL OF MATERIAL
(Deck & Approach)

Structure	Item	Unit	Total
020-0026	Diamond Grinding (Bridge Section)	Sq Yd	1,663.5
	High Friction Surface Treatment For Bridge Deck Surfaces	Sq Yd	1,822.0
	High Friction Surface Treatment Crack Filling	Foot	600.0
020-0027	Diamond Grinding (Bridge Section)	Sq Yd	1,663.5
	High Friction Surface Treatment For Bridge Deck Surfaces	Sq Yd	1,822.0
	High Friction Surface Treatment Crack Filling	Foot	600.0

MODEL: \\MODELS\MHFE
FILE: \\MAILS_P\public\paw_bec\paw.com\FW\DOT\Documents\DOT_Offices\Dir\dir_5\Project\05702628\CAD\Drawings\05702628-EB-Str-020-0026-0027.dgn

USER NAME = erik.shawler	DESIGNED -	REVISED -
	DRAWN -	REVISED -
PLOT SCALE = 40,0000 * / in.	CHECKED -	REVISED -
PLOT DATE = 1/17/2023	DATE -	REVISED -

STATE OF ILLINOIS
DEPARTMENT OF TRANSPORTATION

WEARING SURFACE PLAN			
S.N. 020-0026 (EB) S.N. 020-0027 (WB)			
SCALE:	SHEET 5	OF 12 SHEETS	STA. TO STA.

F.A.I. RTE. 74	SECTION MBPM 2023-1	COUNTY DE WITT	TOTAL SHEETS 28	SHEET NO. 11
			CONTRACT NO. 70G28	
		ILLINOIS FED. AID PROJECT		

PARTIAL DEPTH PATCHING DETAILS (DECK) S.N. 020-0026 (EB) & S.N. 020-0027 (WB)

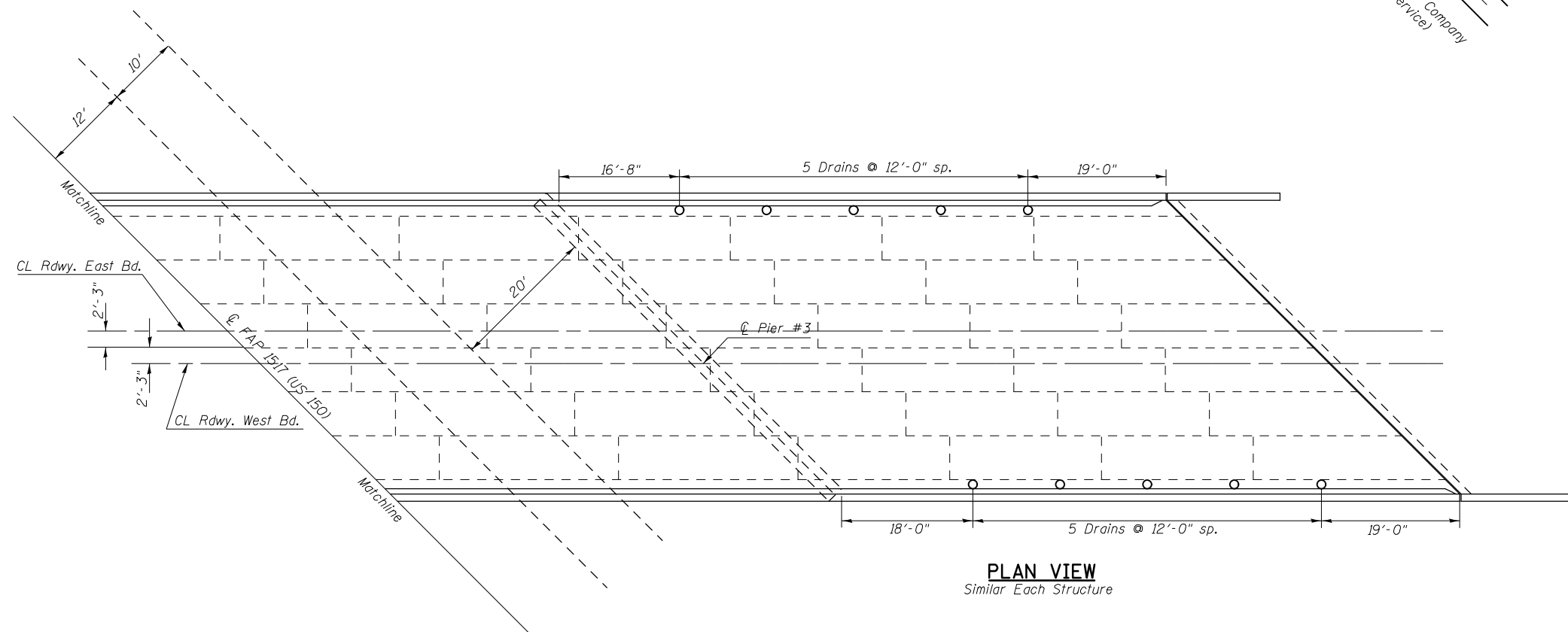
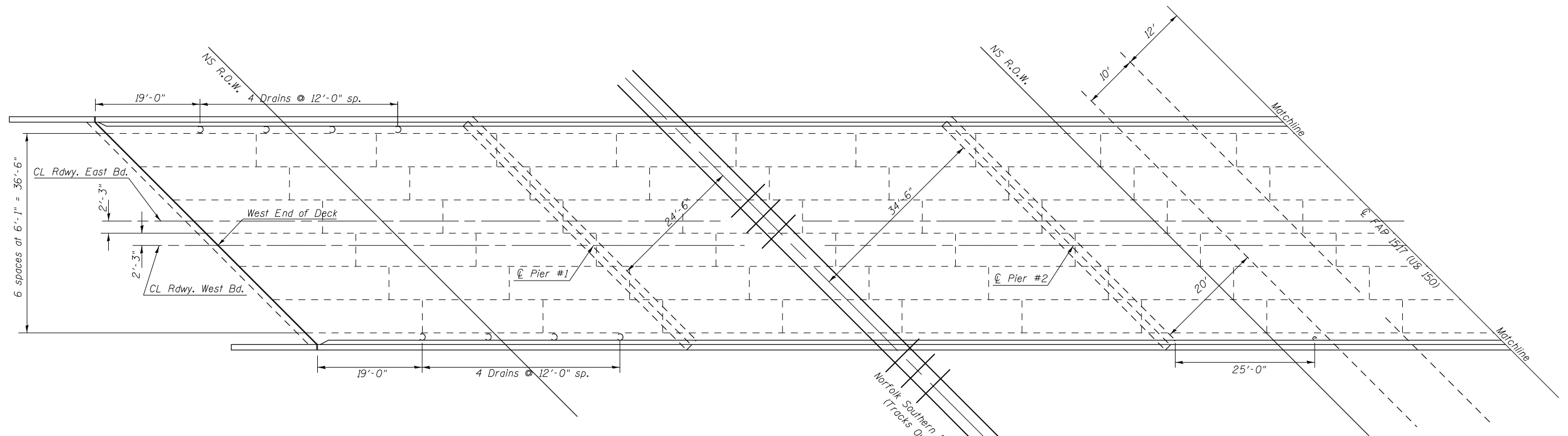

PLAN VIEW
Similar Each Structure

NOTES:

An Estimated 1% of the Deck Area has been included should additional Deck Slab Repair (Partial) be required after Diamond Grinding (Bridge Section).

The actual sizes and locations of patching shall be determined by the engineer. The Engineer shall show the actual locations of the deck repairs on this sheet.

BILL OF MATERIAL

Structure	Item	Unit	Total
020-0026	Deck Slab Repair (Partial Depth)	Sq Yd	16.0
020-0027	Deck Slab Repair (Partial Depth)	Sq Yd	16.0

MODEL: \\MODEL\NAME
 FILE: \\NAME\PROJECT\...
 PROJECT: 020-0026 (EB) & S.N. 020-0027 (WB)
 SHEET: 12 OF 28

USER NAME = erik.shawler	DESIGNED -	REVISED -	
	DRAWN -	REVISED -	
PLOT SCALE = 40,0000 * / in.	CHECKED -	REVISED -	
PLOT DATE = 11/29/2022	DATE -	REVISED -	

**STATE OF ILLINOIS
DEPARTMENT OF TRANSPORTATION**

**PARTIAL DEPTH PATCHING DETAILS (DECK)
S.N. 020-0026 (EB) S.N. 020-0027 (WB)**

SCALE: SHEET 6 OF 12 SHEETS STA. TO STA.

F.A.I. RTE.	SECTION	COUNTY	TOTAL SHEETS	SHEET NO.
74	MBPM 2023-1	DE WITT	28	12
ILLINOIS FED. AID PROJECT			CONTRACT NO. 70G28	

PARTIAL DEPTH PATCHING DETAILS (APPROACH)

S.N. 020-0026 (EB) & S.N. 020-0027 (WB)

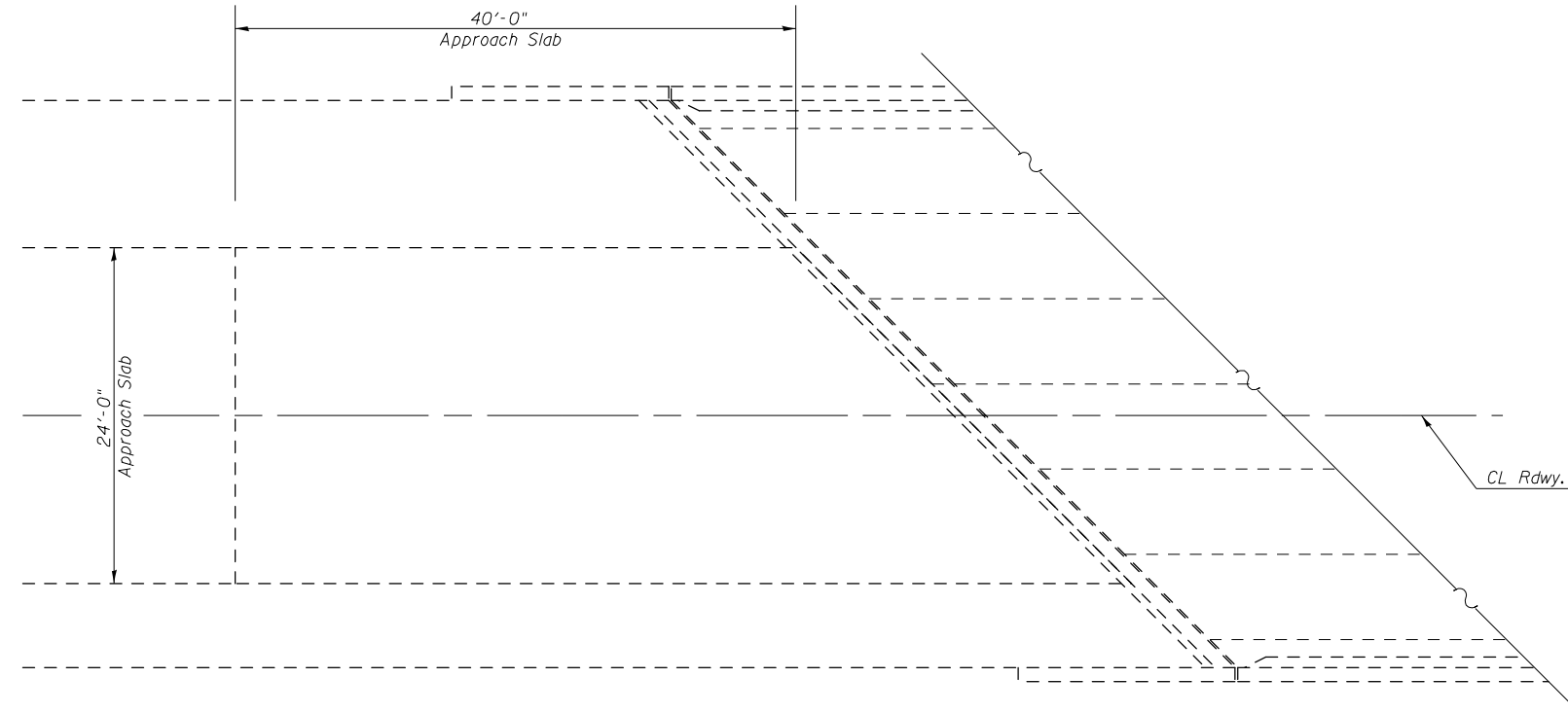

PLAN VIEW
Similar Each Structure

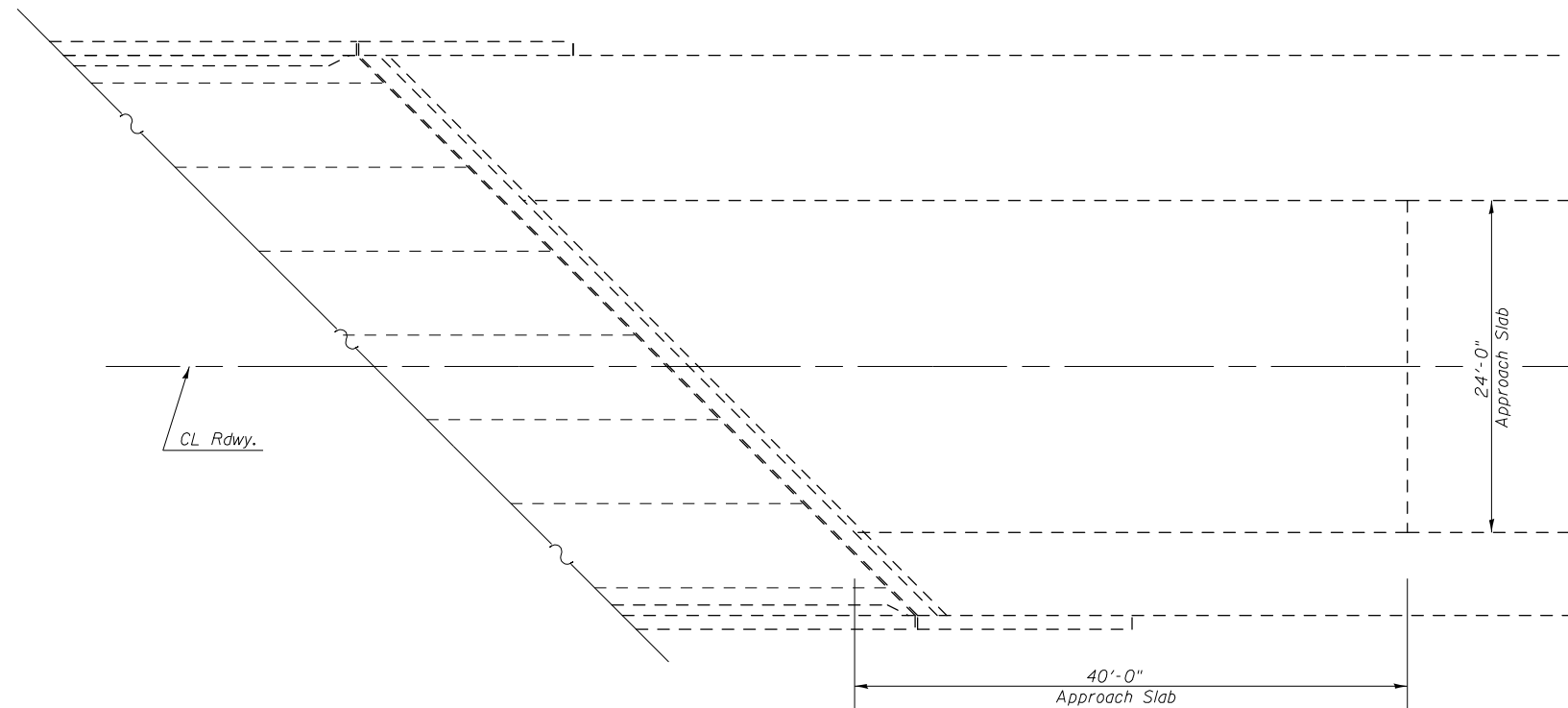

PLAN VIEW
Similar Each Structure

NOTES:

An Estimated 1% of the Deck Area has been included should additional Deck Slab Repair (Partial) be required after Diamond Grinding (Bridge Section).
The actual sizes and locations of patching shall be determined by the engineer. The Engineer shall show the actual locations of the deck repairs on this sheet.

BILL OF MATERIAL

Structure	Item	Unit	Total
020-0026	Approach Slab Repair (Partial Depth)	Sq Yd	3.0
020-0027	Approach Slab Repair (Partial Depth)	Sq Yd	3.0

MODEL: \\MODEL\MNMF5
 FILE: \\MAILS_P\pub\lucy\paw\beadefy.com\PIV\DOT\Documents\DOT_Offices\Dir\drf: S:\Project\05702628\CADD\DATA\CAD\Sheet\05702628-EB-PL-11-020-000-666-0027.dgn

USER NAME = erik.shawler	DESIGNED -	REVISED -
PLOT SCALE = 40,0000 * / in.	DRAWN -	REVISED -
PLOT DATE = 11/29/2022	CHECKED -	REVISED -
	DATE -	REVISED -

**STATE OF ILLINOIS
DEPARTMENT OF TRANSPORTATION**

**PARTIAL DEPTH PATCHING DETAIL (APPROACH)
S.N. 020-0026 (EB) S.N. 020-0027 (WB)**

SCALE: SHEET 7 OF 12 SHEETS STA. TO STA.

F.A.I. RTE.	SECTION	COUNTY	TOTAL SHEETS	SHEET NO.
74	MBPM 2023-1	DE WITT	28	13
CONTRACT NO. 70G28			ILLINOIS FED. AID PROJECT	

SUPERSTRUCTURE PLAN-EAST JOINT S.N. 020-0027 (WB)

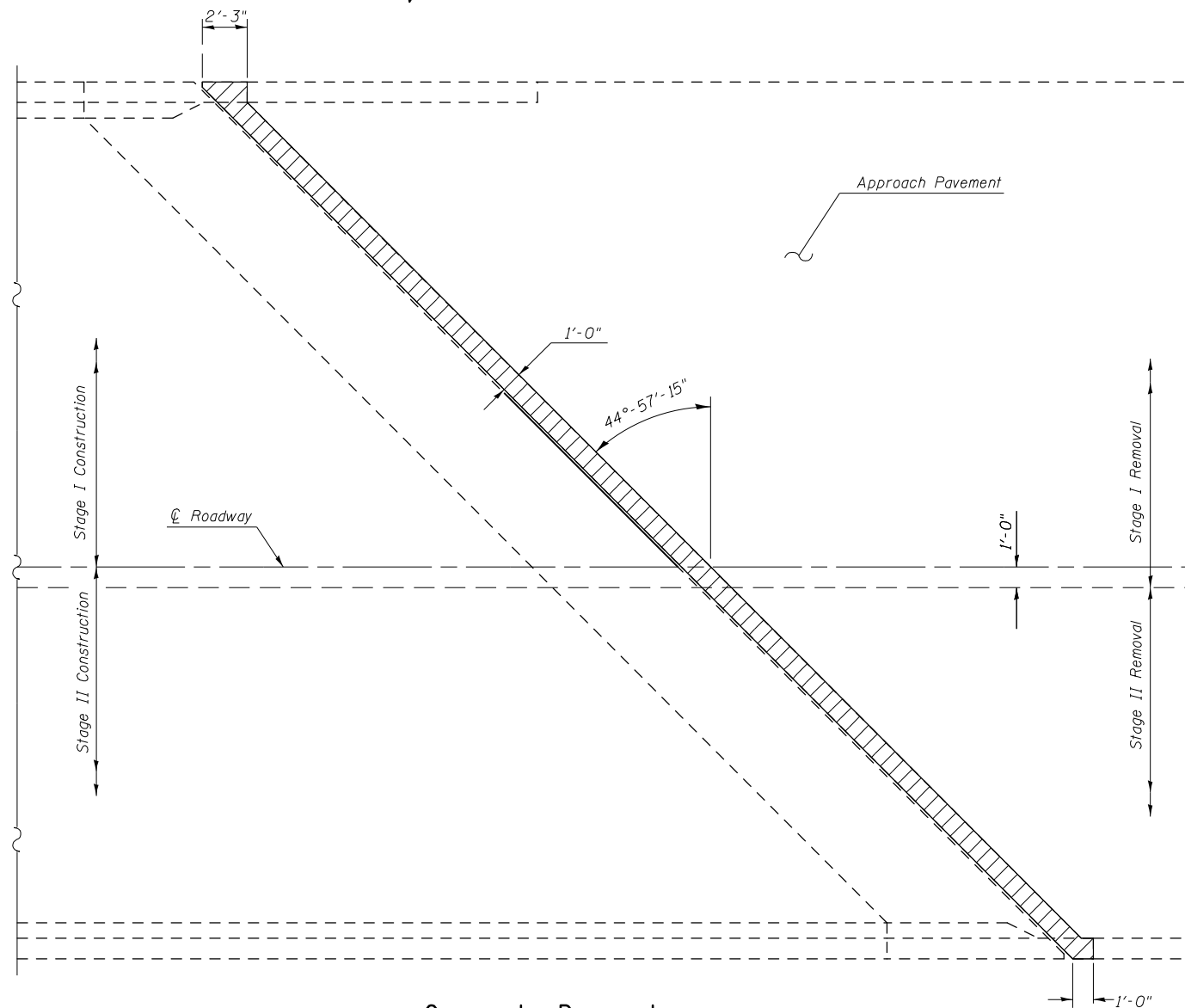

Concrete Removal

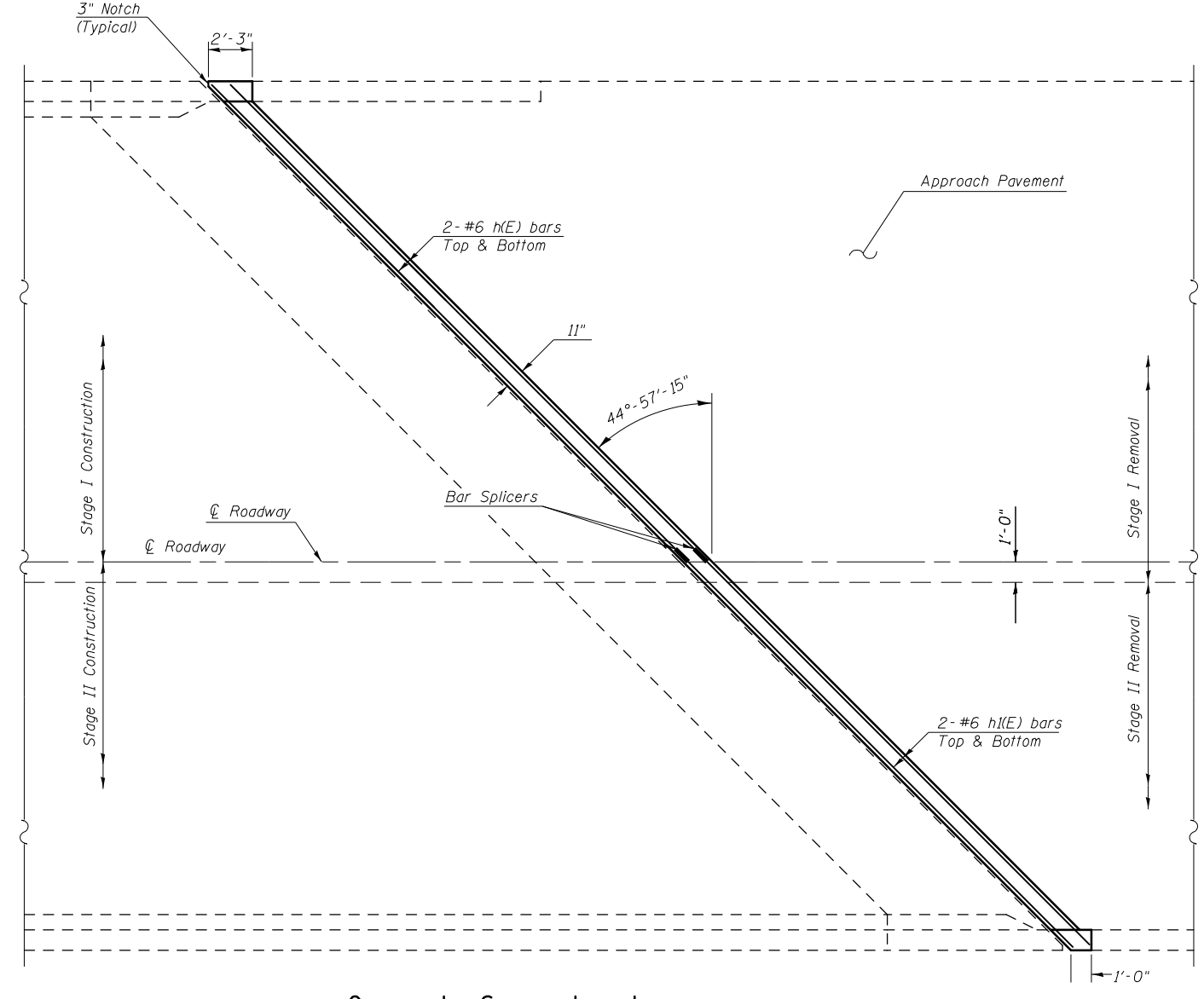

Concrete Superstructure

NOTES:

Existing reinforcement bars extending into the removal area shall be cleaned, straightened and incorporated into the New construction. Any reinforcement bars that are damaged during Concrete Removal shall be replaced with an approved bar splicer or anchorage system. Cost included with Concrete Removal.

Only the Hatch Block Side Armor and Gland shall be removed completely, as well as any foreign material that has accumulated or been placed in the joint openings. The cost for this work is included in Concrete Removal and no additional compensation will be allowed.

The handrail attached to the top of the parapets shall be unbolted to allow for the removal and placement of the parapet ends. Following completion of the parapet ends, the handrail shall be re-attached. The cost of this work shall be included in Concrete Removal & Concrete Superstructures.

Reinforcement Bars Designated (E) shall be Epoxy Coated.

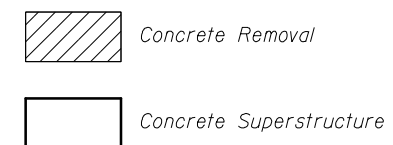

BILL OF MATERIAL

Structure	Item	Unit	Total
020-0027	Reinforcement Bars, Epoxy Coated	Pound	360.0
020-0027	Concrete Removal	Cu Yd	3.3
020-0027	Concrete Superstructure	Cu Yd	3.1
020-0027	Bar Splicers	Each	4.0

MODEL: \\MODEL\MMF5
 FILE: \\MAILS_P\sub\cpx_bec\pfx.com\PIV\DOT\Documents\DOT_Offices\Dir\dr: S:\Project\0570228\CAD\Drawings\0570228-Pl-11-020-000-6660027.dgn

USER NAME = erik.shawler	DESIGNED -	REVISED -
	DRAWN -	REVISED -
PLOT SCALE = 40,0000 * / in.	CHECKED -	REVISED -
PLOT DATE = 11/29/2022	DATE -	REVISED -

**STATE OF ILLINOIS
DEPARTMENT OF TRANSPORTATION**

**SUPERSTRUCTURE PLAN
S.N. 020-0027 (WB)**

SCALE: SHEET 8 OF 12 SHEETS STA. TO STA.

F.A.I. RTE.	SECTION	COUNTY	TOTAL SHEETS	SHEET NO.
74	MBPM 2023-1	DE WITT	28	14
			CONTRACT NO. 70G28	
ILLINOIS FED. AID PROJECT				

SUPERSTRUCTURE PLAN-WEST JOINT S.N. 020-0026 (EB)

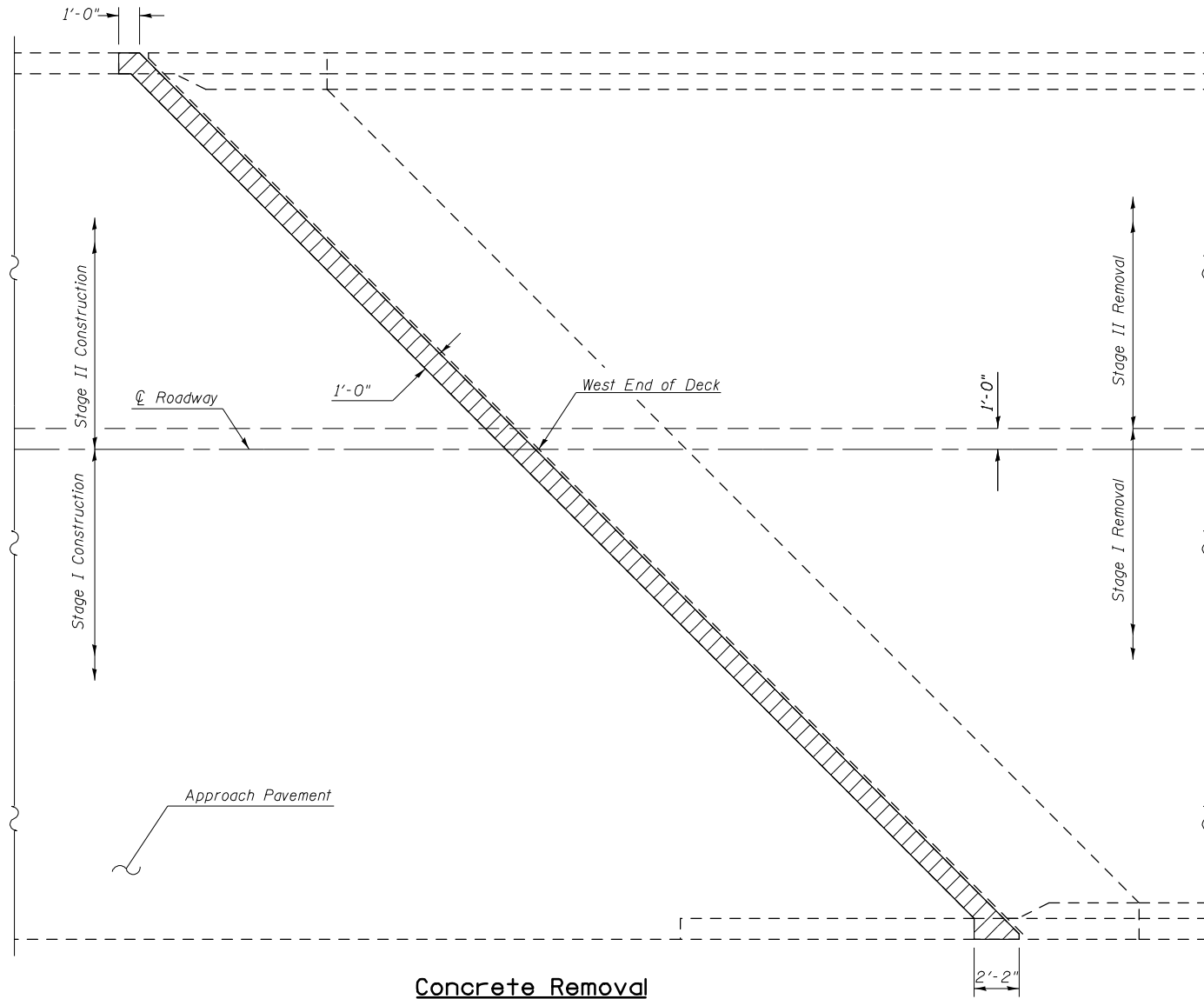

Concrete Removal

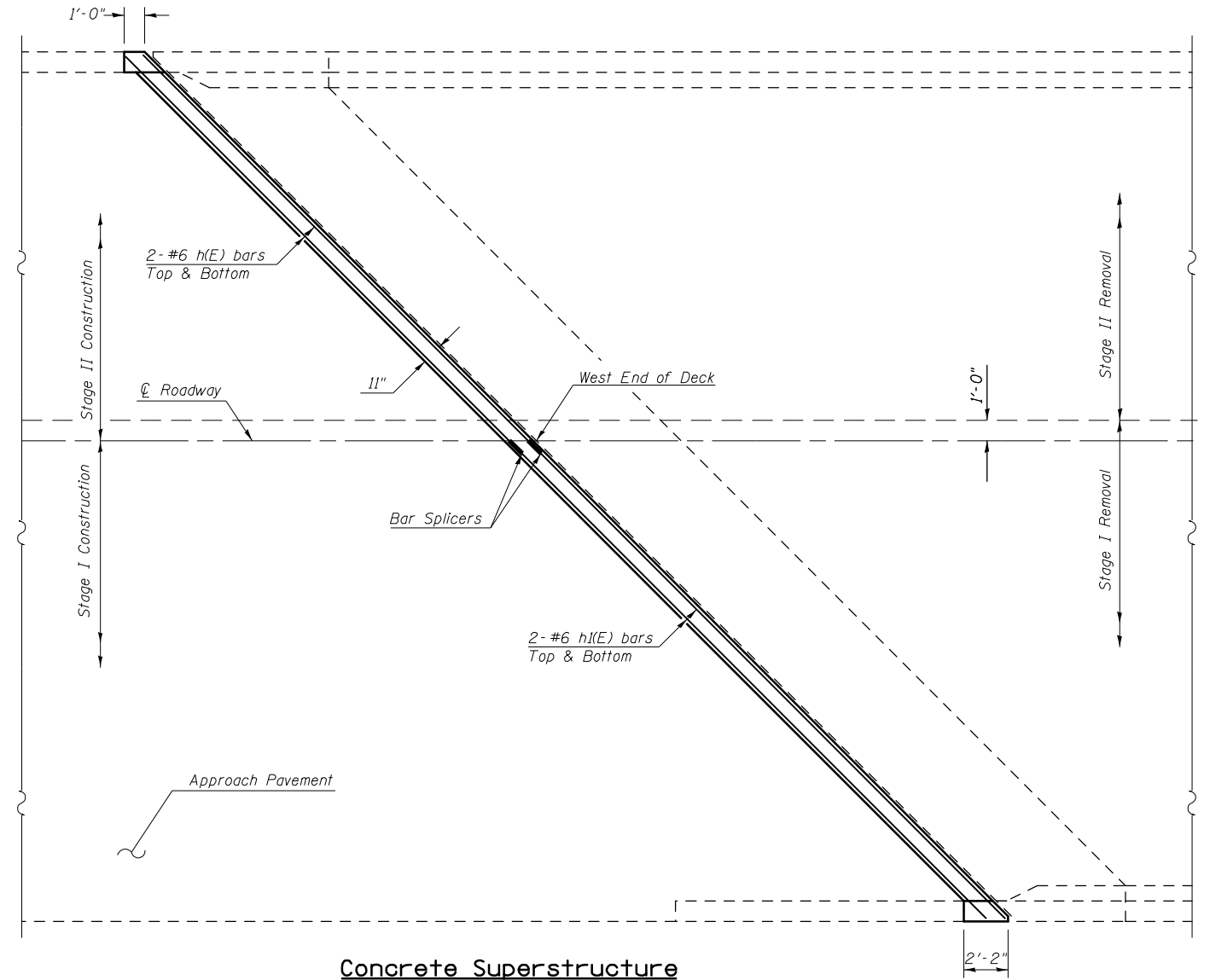

Concrete Superstructure

NOTES:

Existing reinforcement bars extending into the removal area shall be cleaned, straightened and incorporated into the New construction. Any reinforcement bars that are damaged during Concrete Removal shall be replaced with an approved bar splicer or anchorage system. Cost included with Concrete Removal.

Only the Hatch Block Side Armor and Gland shall be removed completely, as well as any foreign material that has accumulated or been placed in the joint openings. The cost for this work is included in Concrete Removal and no additional compensation will be allowed.

The handrail attached to the top of the parapets shall be unbolted to allow for the removal and placement of the parapet ends. Following completion of the parapet ends, the handrail shall be re-attached. The cost of this work shall be included in Concrete Removal & Concrete Superstructures.

Reinforcement Bars Designated (E) shall be Epoxy Coated.

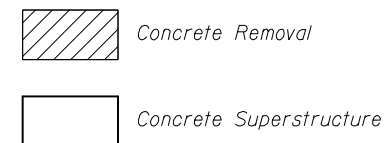

BILL OF MATERIAL

Structure	Item	Unit	Total
020-0026	Reinforcement Bars, Epoxy Coated	Pound	360.0
020-0026	Concrete Removal	Cu Yd	3.3
020-0026	Concrete Superstructure	Cu Yd	3.1
020-0026	Bar Splicers	Each	4.0

MODEL: \\MODEL\MMF5
FILE: \\MAILS_P\public\paw_bec\paw.com\PIV\DOT\Documents\DOT_Offices\Dir\dir: S:\Project\05702628\CAD\Drawings\05702628-Pl-11-020-000-666027.dgn

USER NAME = erik.shawler	DESIGNED -	REVISED -
	DRAWN -	REVISED -
PLOT SCALE = 40,0000 */ in.	CHECKED -	REVISED -
PLOT DATE = 11/29/2022	DATE -	REVISED -

**STATE OF ILLINOIS
DEPARTMENT OF TRANSPORTATION**

**SUPERSTRUCTURE PLAN
S.N. 020-0026 (EB)**

SCALE: SHEET 9 OF 12 SHEETS STA. TO STA.

F.A.I. RTE.	SECTION	COUNTY	TOTAL SHEETS	SHEET NO.
74	MBPM 2023-1	DE WITT	28	15
ILLINOIS FED. AID PROJECT			CONTRACT NO. 70G28	

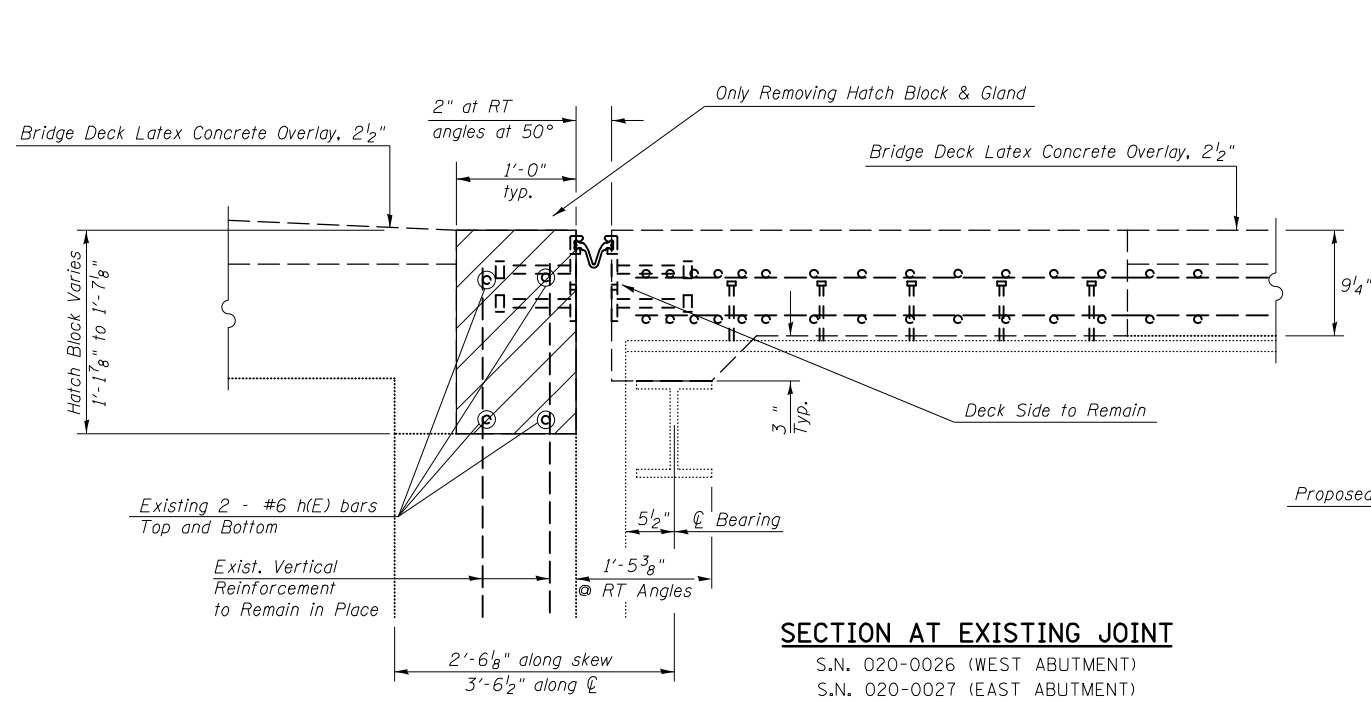

SECTION AT EXISTING JOINT
 S.N. 020-0026 (WEST ABUTMENT)
 S.N. 020-0027 (EAST ABUTMENT)

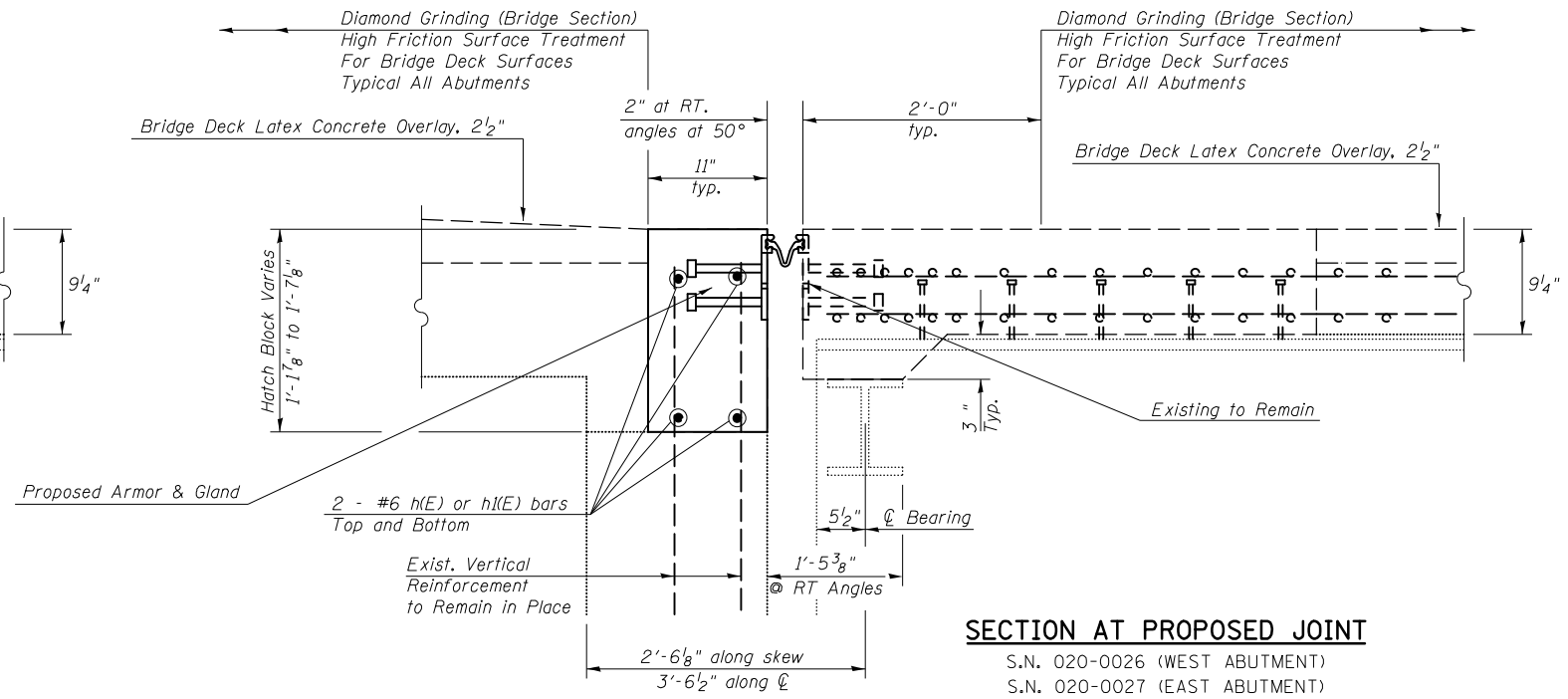

SECTION AT PROPOSED JOINT
 S.N. 020-0026 (WEST ABUTMENT)
 S.N. 020-0027 (EAST ABUTMENT)

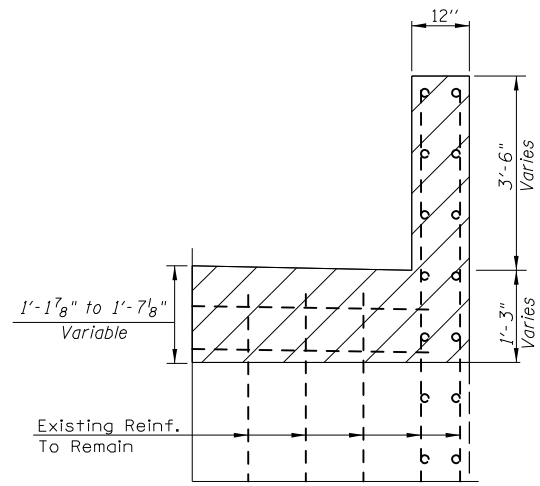

SECTION AT EXISTING WINGWALL

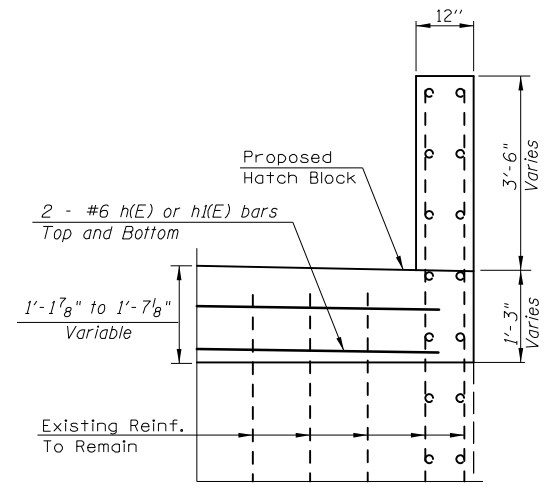

SECTION AT PROPOSED WINGWALL

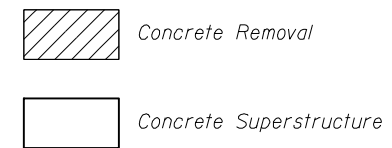

TOTAL BILL OF MATERIAL

BAR	NO.	SIZE	LENGTH	SHAPE
h(E)	8	6	33'-0"	————
h(I(E))	8	6	26'-8"	————

ITEM	UNIT	TOTAL
Reinforcement Bars, Epoxy Coated	Pound	720.0
Concrete Superstructure	Cu Yd	6.2
Concrete Removal	Cu Yd	6.6
Bar Splicers	Each	8.0

MODEL: I:\MODELS\MHFE...
 FILE: MHFE...
 PROJECT: I:\PROJECTS\DOT OFFICES\DIR\...
 SHEET: 16 OF 28

USER NAME = erik.shawler	DESIGNED -	REVISED -
PLOT SCALE = 40,0000 * / in.	DRAWN -	REVISED -
PLOT DATE = 11/29/2022	CHECKED -	REVISED -
	DATE -	REVISED -

**STATE OF ILLINOIS
 DEPARTMENT OF TRANSPORTATION**

JOINT DETAILS			
S.N. 020-0026 (EB) S.N. 020-0027 (WB)			
SCALE:	SHEET 10	OF 12 SHEETS	STA. TO STA.

F.A.I. RTE.	SECTION	COUNTY	TOTAL SHEETS	SHEET NO.
74	MBPM 2023-1	DE WITT	28	16
ILLINOIS FED. AID PROJECT			CONTRACT NO. 70G28	

PREFORMED JOINT STRIP SEAL DETAILS

S.N. 020-0026 (EB) "WEST" HATCH BLOCK ONLY

S.N. 020-0027 (WB) "EAST" HATCH BLOCK ONLY

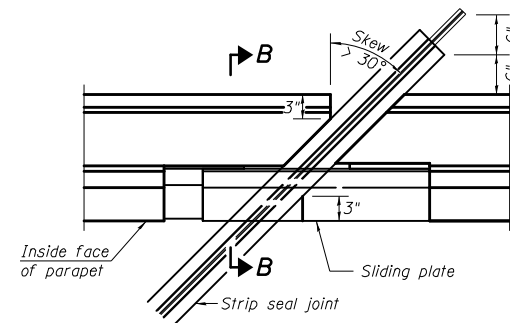

PLAN
(For skews > 30°)
Showing point block

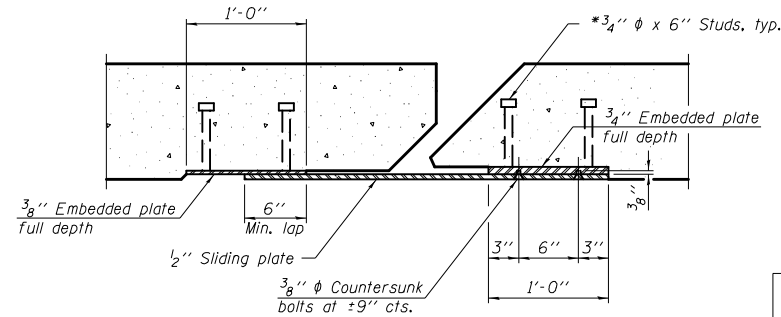

SECTION A-A

HATCH BLOCK SIDE ONLY

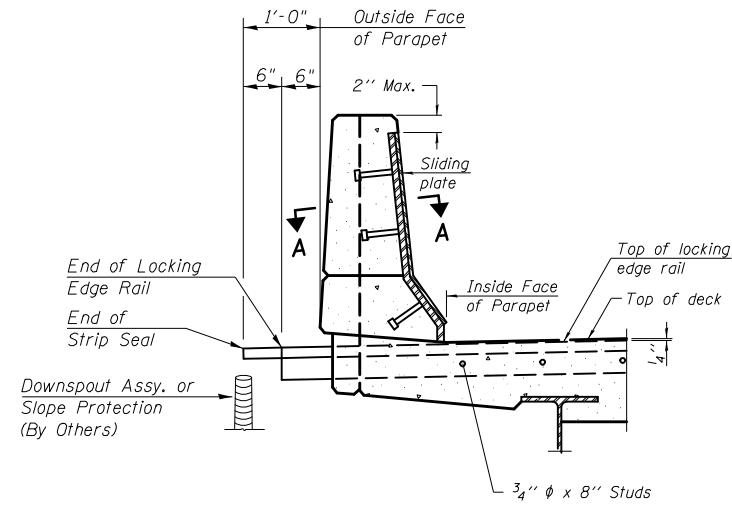

SECTION B-B

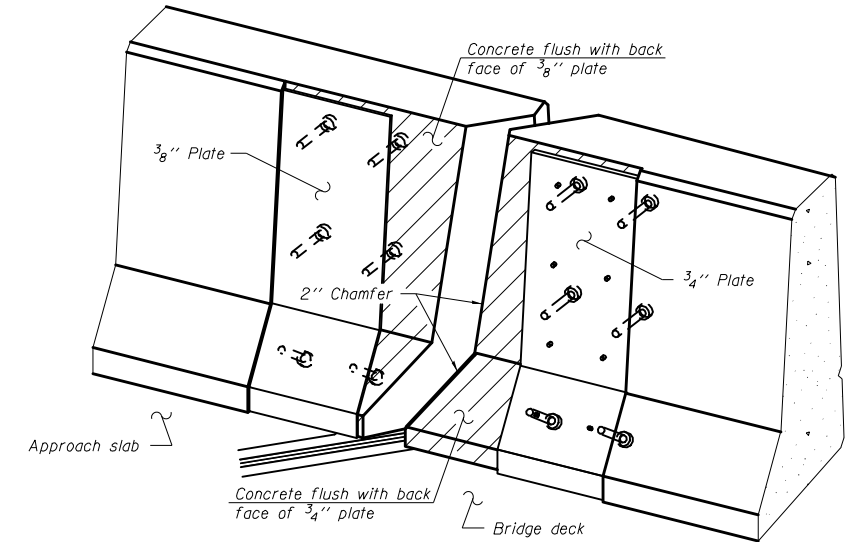

TRIMETRIC VIEW
(Showing back plates only)

SLIDING PLATE IS NOT REQUIRED SINCE EXISTING PARAPET DOES NOT EXTEND ALONG APPROACH SLAB;
I.E. PROPOSED PARAPET AND WINGWALL DIMENSIONS MATCH EXISTING CONDITIONS

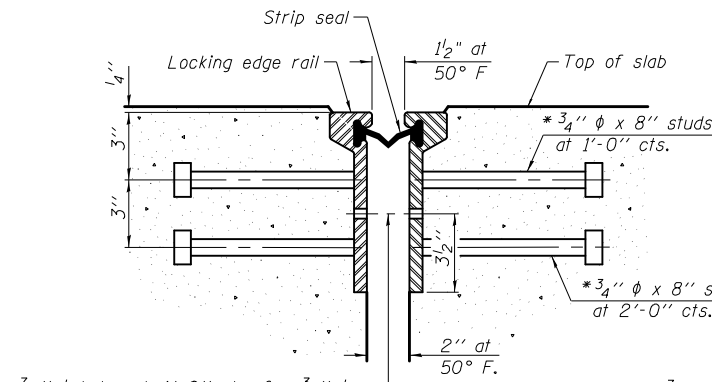

SECTION THRU ROLLED RAIL JOINT

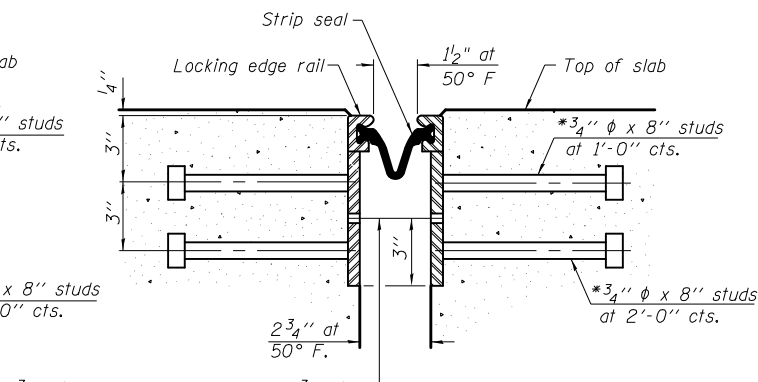

SECTION THRU WELDED RAIL JOINT

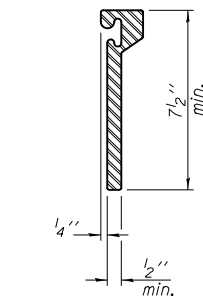

ROLLED EXTRUDED RAIL

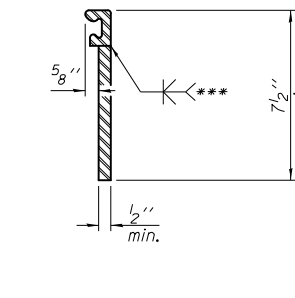

WELDED RAIL

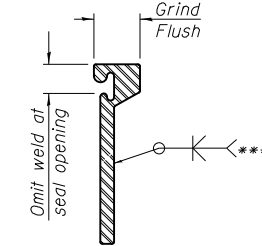

LOCKING EDGE RAIL SPLICE

7/16" ϕ holes at 4'-0" cts. for 3/8" ϕ bolts. All bolts shall be burned, sawed, or chipped off flush with the plates after forms are removed, typ.

7/16" ϕ holes at 4'-0" cts. for 3/8" ϕ bolts. All bolts shall be burned, sawed, or chipped off flush with the plates after forms are removed, typ.

*** Back gouge not required if complete joint penetration is verified by mock-up.

The inside of the locking edge rail groove shall be free of weld residue.
Rolled rail shown, welded rail similar.

Notes:
The strip seal shall be made continuous and shall have a minimum thickness of 1/4". The configuration of the strip seal shall match the configuration of the Locking Edge Rails. Open or "webbed" strip seal gland configurations are not permitted. The gland shall be sized for a maximum rated movement of 4 inches.

The strip seal shall be inserted into the Locking Edge Rails before the parapet ends are formed and poured to allow for proper placement of the strip seal.

The Locking Edge Rails depicted are conceptual only, except for the minimum dimensions shown. The actual configuration of the Locking Edge Rails and matching strip seal may vary from manufacturer to manufacturer. Flanged edge rails will not be allowed. Locking Edge Rails may be spliced at slope discontinuities.

The manufacturer's recommended installation methods shall be followed.

The joint opening and deck dimensions detailed on the superstructure are based on a rolled rail expansion joint. If the Contractor elects to use the welded rail expansion joint, the opening and deck dimensions shall be modified according to the dimensions detailed on this sheet. Required modifications shall be made at no additional cost to the State.

All steel components shall be galvanized after fabrication according to Article 520.03 of the Standard Specifications.

Maximum space between rail segments at stage lines shall be 3/16", sealed with a suitable sealant.

Parapet plates and anchorage studs for skews > 30° included in the cost of Preformed Joint Strip Seal.

BILL OF MATERIAL

Structure	Item	Unit	Total
020-0026	Preformed Joint Strip Seal	Foot	61.5
020-0027	Preformed Joint Strip Seal	Foot	61.5

* Granular or solid flux filled headed studs conforming to Article 1006.32 of the Std. Specs., automatically end welded.

•20-1(HVB,HB-1,VB-1,B,B-1)I

MODEL: I:\MODEL\MHMF5... FILE: MHMF5... PROJECT: I:\PROJECTS\DOT\... OFFICE: DISTRICT 5... DATE: 11/29/2022

USER NAME = erik.shawler	DESIGNED -	REVISED -
PLOT SCALE = 40,0000 */ in.	DRAWN -	REVISED -
PLOT DATE = 11/29/2022	CHECKED -	REVISED -
	DATE -	REVISED -

**STATE OF ILLINOIS
DEPARTMENT OF TRANSPORTATION**

**PREFORMED JOINT STRIP SEAL DETAILS
S.N. 020-0026 (EB) S.N. 020-0027 (WB)**

SCALE: SHEET 11 OF 12 SHEETS STA. TO STA.

F.A.I. RTE.	SECTION	COUNTY	TOTAL SHEETS	SHEET NO.
74	MBPM 2023-1	DE WITT	28	17
			CONTRACT NO. 70G28	
ILLINOIS FED. AID PROJECT				

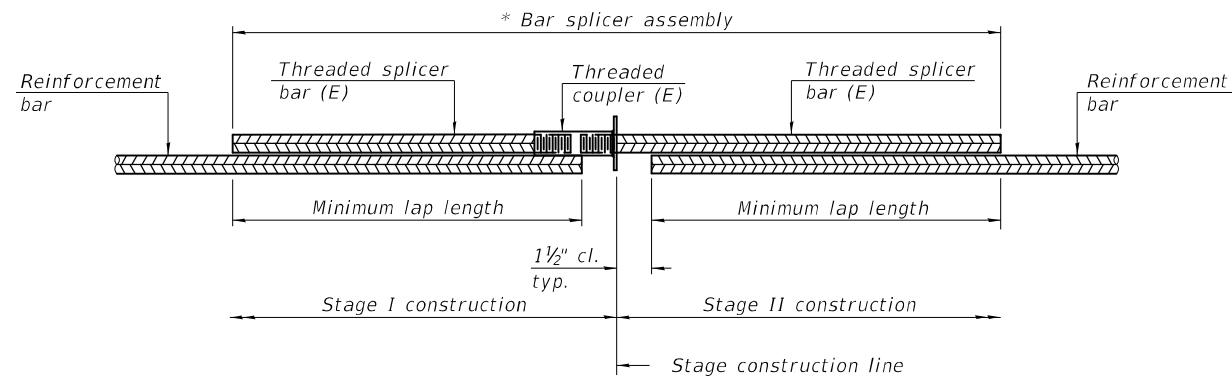

STANDARD BAR SPLICER ASSEMBLY PLAN
 (All components shall be provided from one supplier)

Threaded splicer bar length = min. lap length + 1 1/2" + thread length

* Epoxy not required on Bar Splicer Assembly components used in conjunction with black bars.

Location	Bar size	No. assemblies required	Minimum lap length
HATCH BLOCKS	#6	8	4'-0"

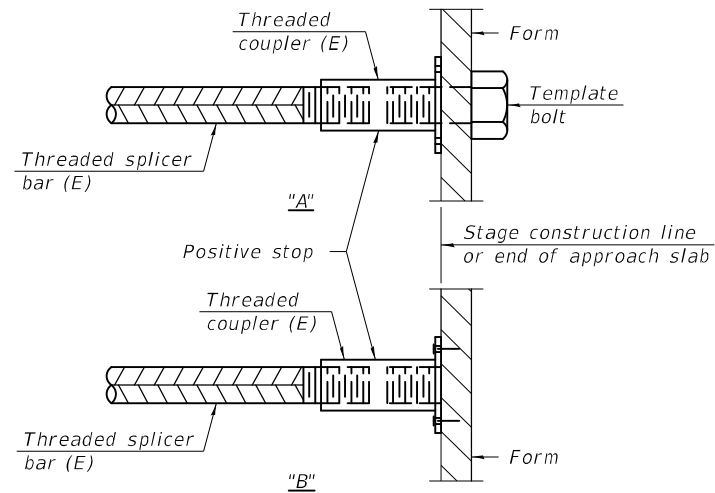

INSTALLATION AND SETTING METHODS

"A" : Set bar splicer assembly by means of a template bolt.

"B" : Set bar splicer assembly by nailing to wood forms or cementing to steel forms.

(E) : Indicates epoxy coating.

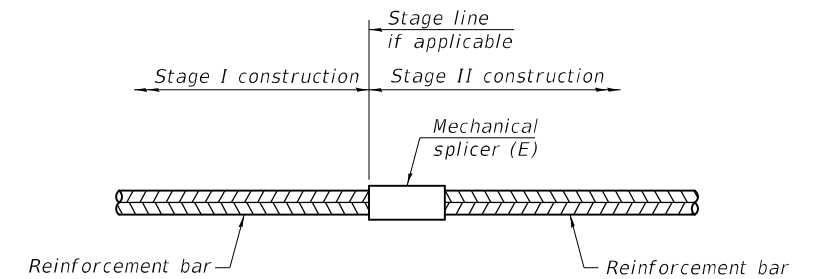

STANDARD MECHANICAL SPLICER

Location	Bar size	No. assemblies required

Notes:

Splicer bars shall be deformed with threaded ends and have a minimum 60 ksi yield strength.

All reinforcement shall be lapped and tied to the splicer bars.

Bar splicer assemblies shall be epoxy coated according to the requirements for reinforcement bars. See Section 508 of the Standard Specifications.

See approved list of bar splicer assemblies and mechanical splicers for alternatives.

MODEL: I:\MODELS\MHFE
 FILE: MHFE.dwg
 PLOT DATE: 11/29/2022
 PROJECT: I:\PROJECTS\70G28\CAD\DATA\CAD\Drawings\70G28\12-Struct\020-000-660027.dwg

BSD-1

1-1-2020

USER NAME = erik.shawler	DESIGNED -	REVISED -
PLOT SCALE = 40,0000 * / in.	DRAWN -	REVISED -
PLOT DATE = 11/29/2022	CHECKED -	REVISED -
	DATE -	REVISED -

**STATE OF ILLINOIS
 DEPARTMENT OF TRANSPORTATION**

BAR SPLICER ASSEMBLY AND MECHANICAL SPLICER DETAILS
STRUCTURE NO.

SCALE: SHEET 12 OF 12 SHEETS STA. TO STA.

F.A.I. RTE.	SECTION	COUNTY	TOTAL SHEETS	SHEET NO.
74	MBPM 2023-1	DE WITT	28	18
ILLINOIS FED. AID PROJECT			CONTRACT NO. 70G28	

The existing structures were built in 1970 as Route FAI-74, Section 20-1HB-1st Sta. 775+53.18 in DeWitt County. The structures carry I-74 over FAS 2495 North of Farmer City. In 1975 a waterproofing membrane and HMA wearing surface was placed under Section D5 Bridge Deck Waterproofing 1975-3, Contract 29686. In 1990 the abutment joints were reconstructed as Section D5 Bridge Repair 1989-2, Contract 90084. In 2004 the HMA wearing surface was removed and replaced with Section 74(3RS-2, 4-1-RS-1), Contract 70027.

The superstructure consists of six 27" rolled steel beams supporting a 8" R.C. deck and 1 3/4" HMA wearing surface with waterproofing membrane system. The substructure consists of concrete pile supported stub abutments and timber pile supported piers. The structures measure 109'-0" bk. to bk. abutments and 42'-0" out to out of deck. The horizontal clearance is 38'-6" from face to face of hub guard. The spans measure 32'-10", 38'-6", and 32'-10".

GENERAL PLAN & ELEVATION

S.N. 020-0028 (EB) & S.N. 020-0029 (WB)

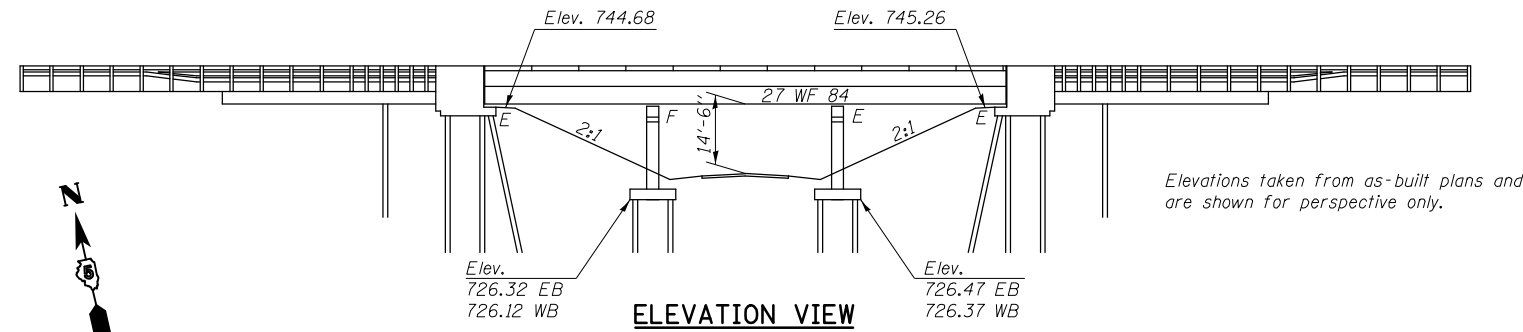

Elevations taken from as-built plans and are shown for perspective only.

PROPOSED WORK

1. Perform Partial Depth Patching in Approach and Bridge Deck.
2. Diamond Grind Bridge Deck and Approach Slabs at a depth of 1/8".
3. Place High Friction Surface Treatment Crack Filling on Bridge Deck Slab and Approach Slabs.
4. Place High Friction Surface Treatment on Bridge Deck Slab and Approach Slabs.

TOTAL BILL OF MATERIAL

ITEM	UNIT	TOTAL
HIGH FRICTION SURFACE TREATMENT FOR BRIDGE DECK SURFACES	SQ YD	1,314.0
HIGH FRICTION SURFACE TREATMENT CRACK FILLING	FOOT	800.0
APPROACH SLAB REPAIR (PARTIAL DEPTH)	SQ YD	5.0
DECK SLAB REPAIR (PARTIAL DEPTH)	SQ YD	10.0
DIAMOND GRINDING (DECK SECTION)	SQ YD	1,224.0

GENERAL NOTES

Plan dimensions and details relative to the existing structure have been taken from existing plans and are subject to nominal construction variations. It shall be the Contractor's responsibility to verify such dimensions and details in the field and make the necessary approved adjustments prior to construction or ordering of materials. Such variations shall not be cause for additional compensation for a change in the scope of work. However, the Contractor will be paid for the quantity actually furnished at the unit price for the work.

Existing Pavement Markings and Raised Reflective Pavement Markers shall be Temporarily Covered Prior to Applications of the Deck Surface Treatment to Prevent the Material from Being Applied to the Markings and Markers. The Temporary Covering shall be Removed After Application of the Deck Surface Treatment and Prior to Opening to Traffic Cost is Included with the Deck Surface Treatment Specified.

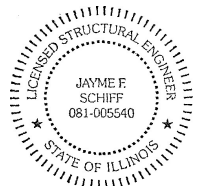
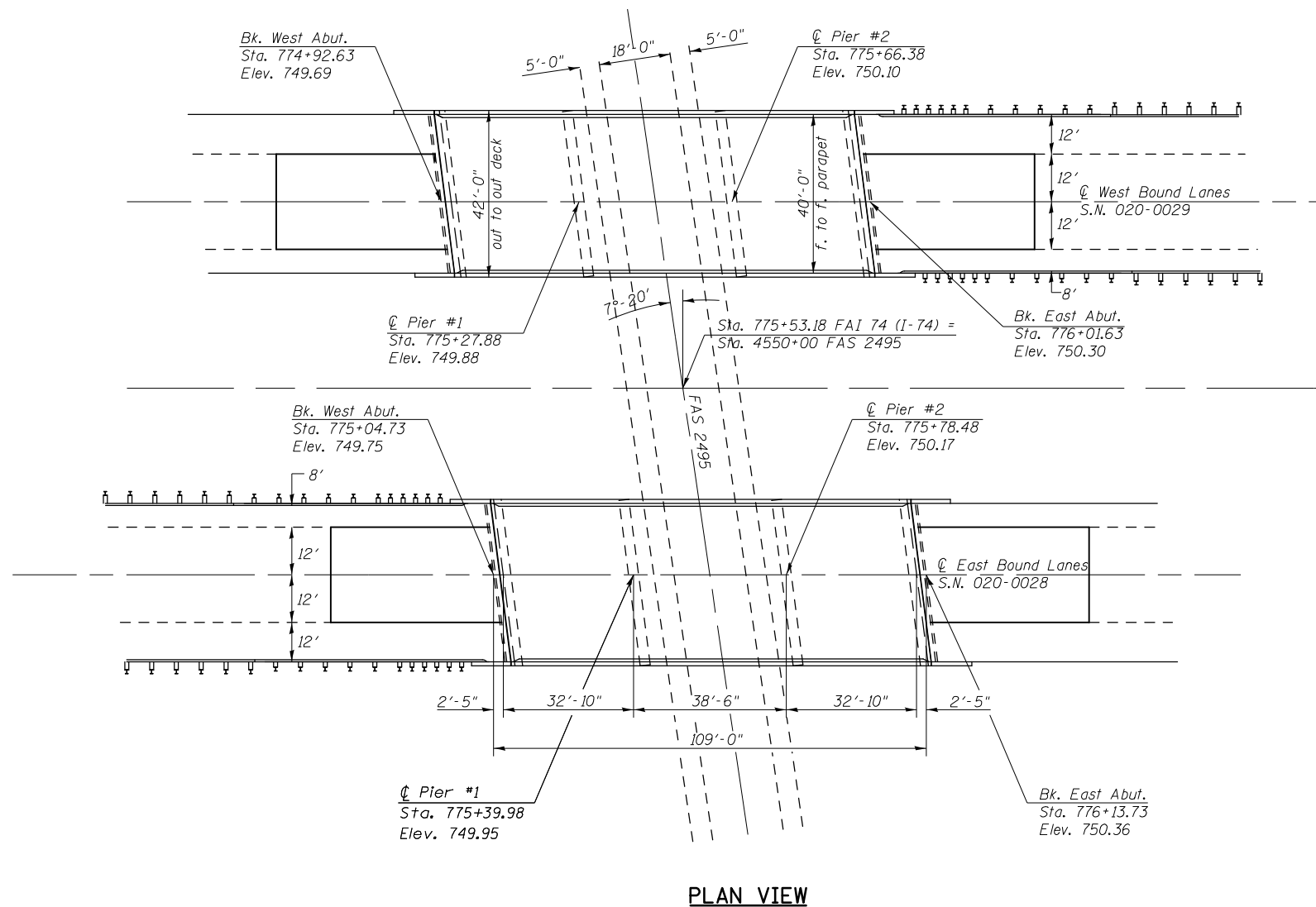

Expires 11-30-2024

Jayme F. Schiff

MODEL: \\MODEL\MAME FILE: \\MAILS_P\jlschiff\paw\beadefw.com\PIV\DOT\Documents\DOT\diff\res\Drawn: S:\Projects\05702\B\CAD\Drawn\CAD\res\res\05702\EB-H-1-020-0028-0029.dgn

USER NAME = erik.shawler	DESIGNED -	REVISED -
PLOT SCALE = 40,0000 * / in.	DRAWN -	REVISED -
PLOT DATE = 11/29/2022	CHECKED -	REVISED -
	DATE -	REVISED -

**STATE OF ILLINOIS
DEPARTMENT OF TRANSPORTATION**

GENERAL PLAN & ELEVATION		F.A.I. RTE.	SECTION	COUNTY	TOTAL SHEETS	SHEET NO.
S.N. 020-0028 (EB) & S.N. 020-0029 (WB)		74	MBPM 2023-1	DE WITT	28	19
SCALE: SHEET 1 OF 6 SHEETS STA. TO STA.		CONTRACT NO. 70G28				
		ILLINOIS FED. AID PROJECT				

•20-1(HVB,HB-1,VB-1,B,B-1)I

EXISTING CROSS SECTION

S.N. 020-0028 (EB) & S.N. 020-0029 (WB)

*Looking East on East Bound Structure
Looking West on West Bound Structure*

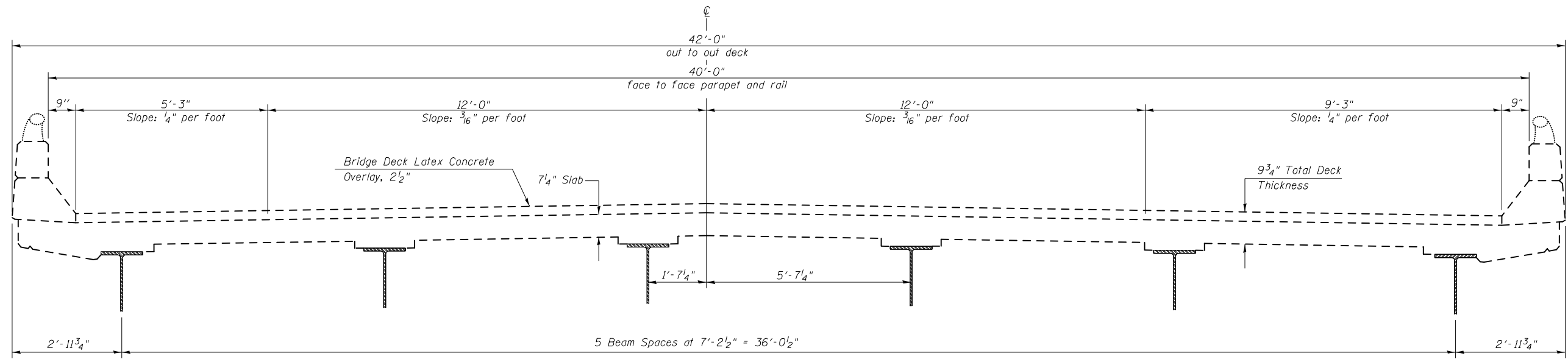

PROPOSED CROSS SECTION

S.N. 020-0028 (EB) & S.N. 020-0029 (WB)

*Looking East on East Bound Structure
Looking West on West Bound Structure*

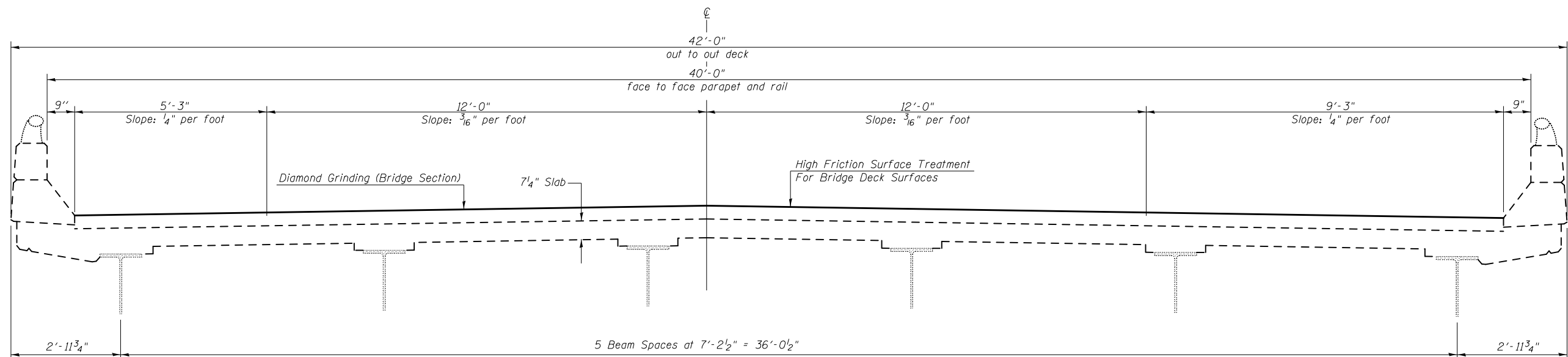

MODEL: \\MODEL\MAMFE
FILE: \\MAILS_P\public\paw_bec@idm.com\FW\DOT\Documents\DOT_Offices\DirDir: S:\Project\057028\02028\CAD\Drawings\057028\EB-WB-Str-020-0028-0029.dgn

USER NAME = erikshawler	DESIGNED -	REVISED -
PLOT SCALE = 40,0000 * / in.	DRAWN -	REVISED -
PLOT DATE = 1/17/2023	CHECKED -	REVISED -
	DATE -	REVISED -

**STATE OF ILLINOIS
DEPARTMENT OF TRANSPORTATION**

**EXISTING & PROPOSED DECK CROSS SECTION
S.N. 020-0028 (EB) & S.N. 020-0029 (WB)**

SCALE: SHEET 2 OF 6 SHEETS STA. TO STA.

F.A.I. RTE.	SECTION	COUNTY	TOTAL SHEETS	SHEET NO.
74	MBPM 2023-1	DE WITT	28	20
			CONTRACT NO. 70G28	
ILLINOIS FED. AID PROJECT				

STAGE I CONSTRUCTION DETAILS

S.N. 020-0028 (EB) & S.N. 020-0029 (WB)

Looking East on East Bound Structure
Looking West on West Bound Structure

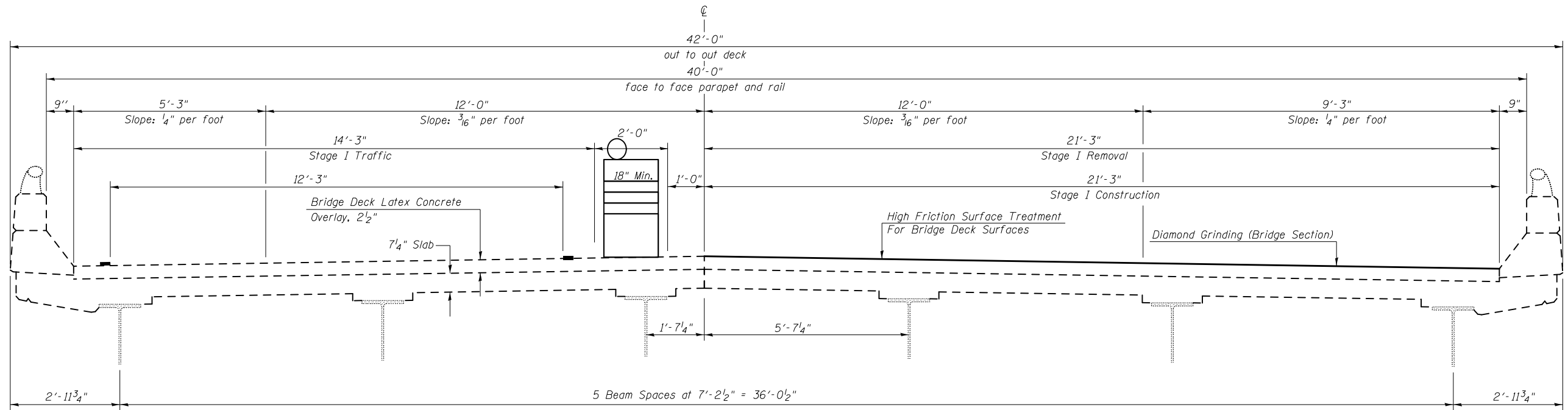

STAGE II CONSTRUCTION

S.N. 020-0028 (EB) & S.N. 020-0029 (WB)

Looking East on East Bound Structure
Looking West on West Bound Structure

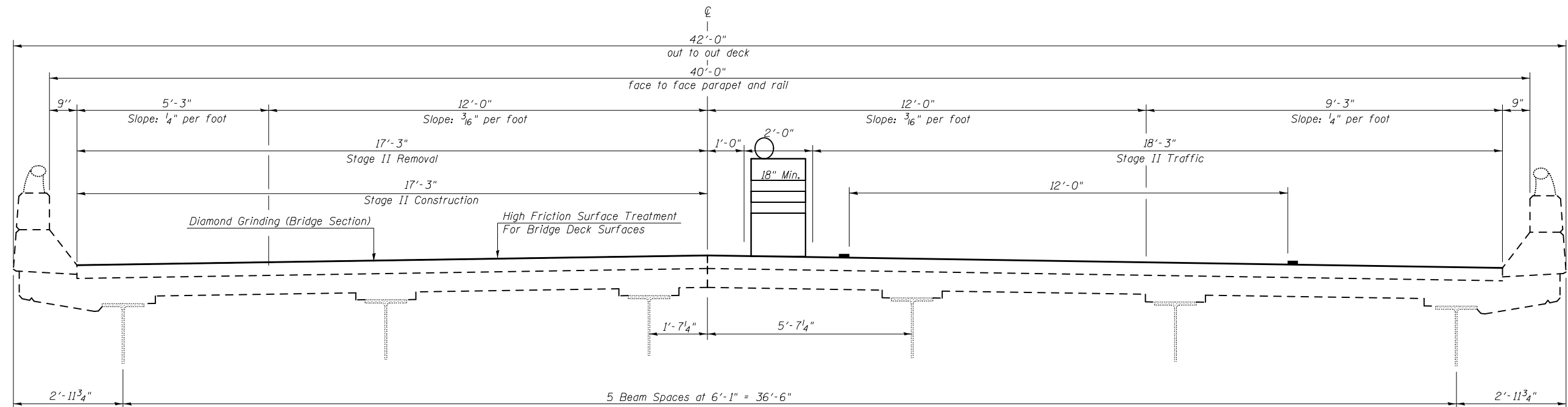

MODEL: \\MODEL\MARIS... FILE: \\MARIS... \Project\057028\B\CAD\Drawings\DOT\Drawings\StageI\057028-EB-1-020-0028-0029.dgn

USER NAME = erik.shawler	DESIGNED -	REVISED -
	DRAWN -	REVISED -
PLOT SCALE = 40,0000 * / in.	CHECKED -	REVISED -
PLOT DATE = 11/29/2022	DATE -	REVISED -

**STATE OF ILLINOIS
DEPARTMENT OF TRANSPORTATION**

STAGED CONSTRUCTION DETAILS
S.N. 020-0028 (EB) & S.N. 020-0029 (WB)

SCALE: SHEET 3 OF 6 SHEETS STA. TO STA.

F.A.I. RTE.	SECTION	COUNTY	TOTAL SHEETS	SHEET NO.
74	MBPM 2023-1	DE WITT	28	21
CONTRACT NO. 70G28			ILLINOIS FED. AID PROJECT	

WEARING SURFACE PLAN S.N. 020-0028 (EB) & S.N. 020-0029 (WB)

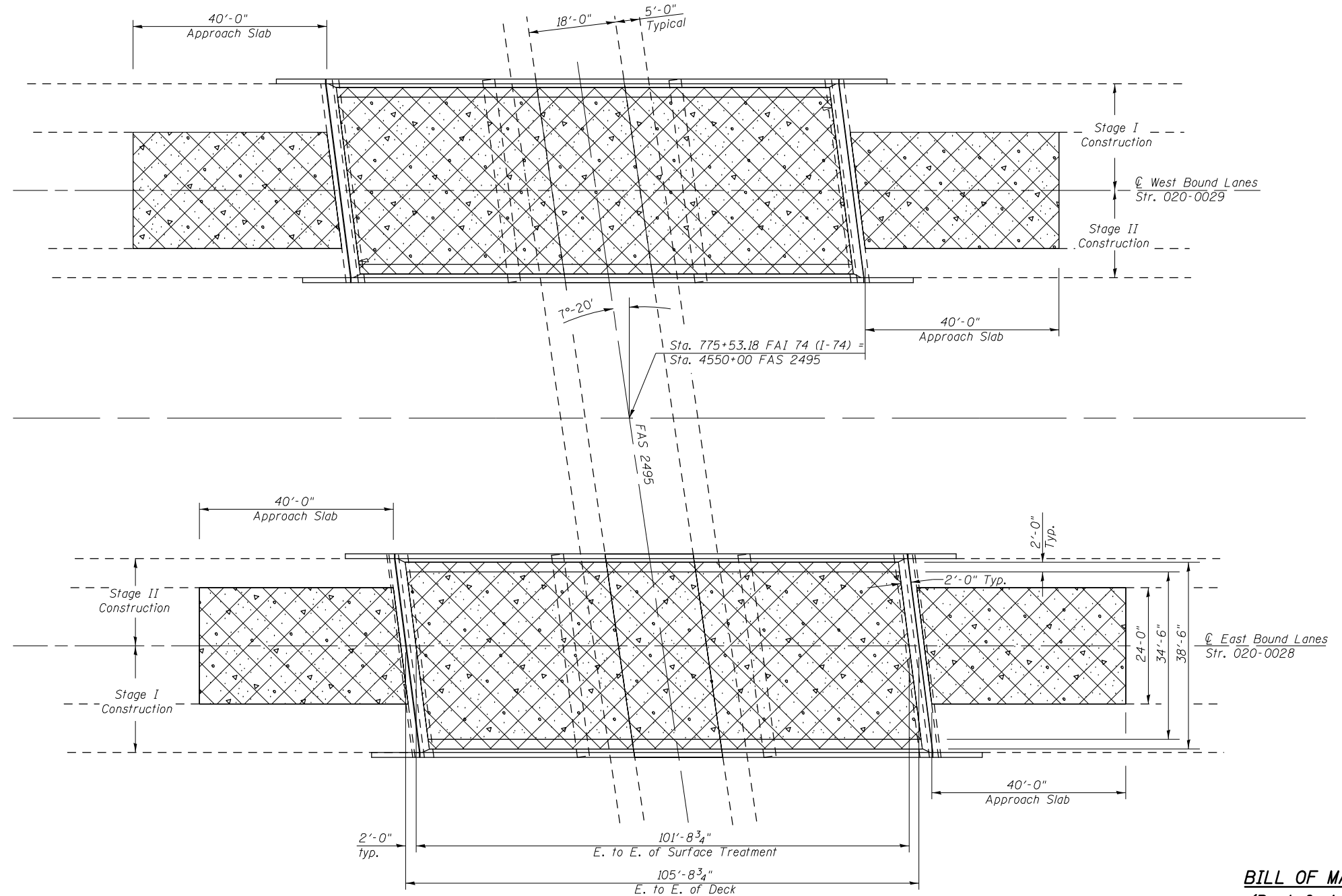

NOTES:

Diamond Grinding (Bridge Section) and High Friction Surface Treatment For Deck Surface Will Not Be Applied to the 1'-0" Hatch Block or the 2'-0" Deck Surface.

Deck Drains and Joints Shall Be Temporary Covered Before the High Friction Surface Treatment is Applied To Protect and Cover Run Off. The Material Used to Cover the Drains and Joints Shall Be Removed and Disposed of Upon the Completion of the High Friction Surface Treatment. Cost Included with High Friction Surface Treatment.

Placement of the Overlapping High Friction Surface Treatment Joint Will Not Be Allowed at the Wheel Lanes.

Diamond Grinding (Bridge Section)

High Friction Surface Treatment For Deck Surfaces

**BILL OF MATERIAL
(Deck & Approach)**

Structure	Item	Unit	Total
020-0028	Diamond Grinding (Bridge Section)	Sq Yd	612.0
	High Friction Surface Treatment For Bridge Deck Surfaces	Sq Yd	657.0
	High Friction Surface Treatment Crack Filling	Foot	400.0
020-0029	Diamond Grinding (Bridge Section)	Sq Yd	612.0
	High Friction Surface Treatment For Bridge Deck Surfaces	Sq Yd	657.0
	High Friction Surface Treatment Crack Filling	Foot	400.0

MODEL: I:\MODEL\MHFS... PROJECT: I:\PROJECTS\020\020\020\CAD\Drawings\020\020\020\020.dwg

USER NAME = erik.shawler	DESIGNED -	REVISED -
	DRAWN -	REVISED -
PLOT SCALE = 40,0000 * / in.	CHECKED -	REVISED -
PLOT DATE = 1/17/2023	DATE -	REVISED -

**STATE OF ILLINOIS
DEPARTMENT OF TRANSPORTATION**

**PARTIAL DEPTH PATCHING DETAILS (DECK)
S.N. 020-0028 (EB) & S.N. 020-0029 (WB)**

SCALE: SHEET 4 OF 6 SHEETS STA. TO STA.

F.A.I. RTE. 74	SECTION MBPM 2023-1	COUNTY DE WITT	TOTAL SHEETS 28	SHEET NO. 22
ILLINOIS FED. AID PROJECT			CONTRACT NO. 70G28	

PARTIAL DEPTH PATCHING DETAILS (DECK) S.N. 020-0028 (EB) & S.N. 020-0029 (WB)

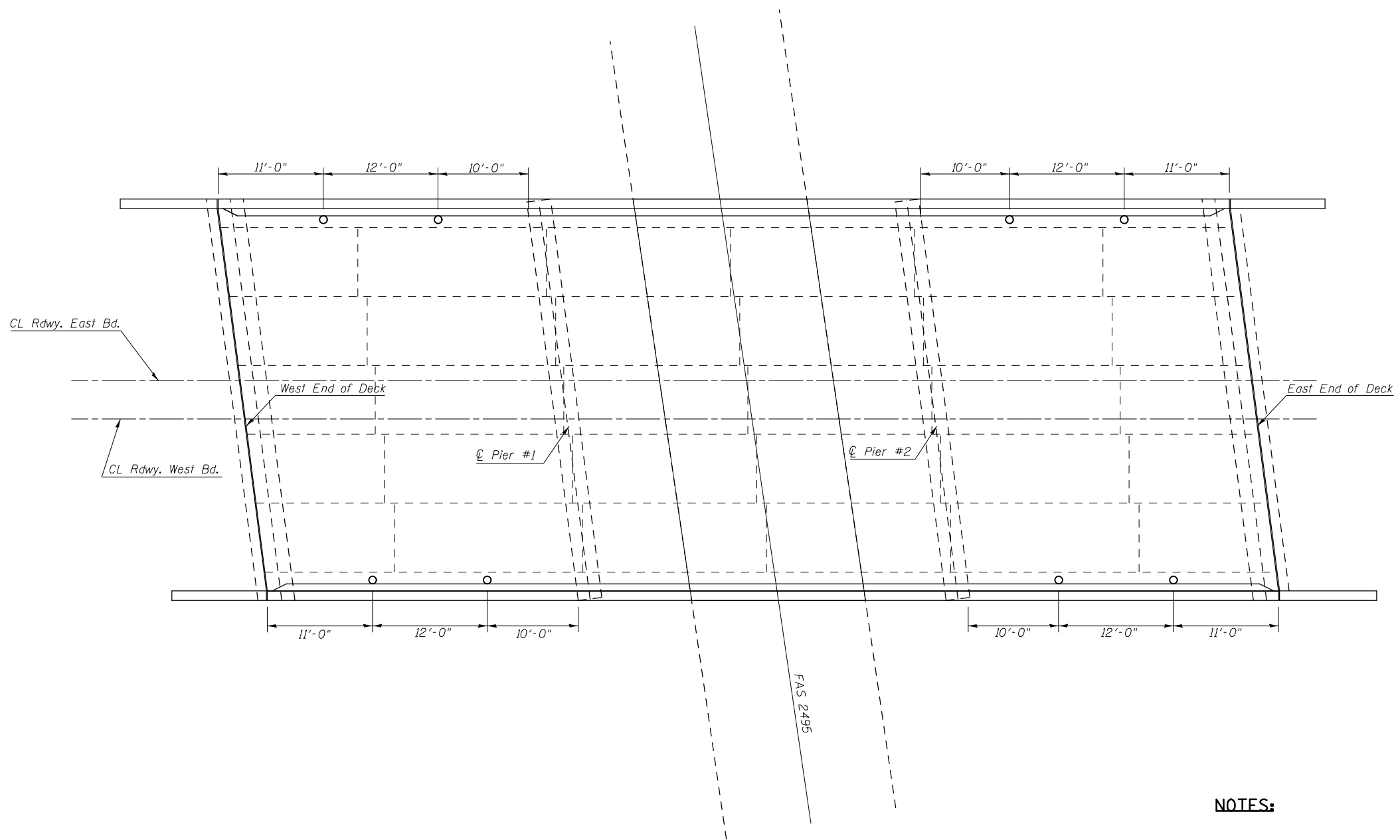

PLAN VIEW
Either Structure

NOTES:

An Estimated 1% of the Deck Area has been included should additional Deck Slab Repair (Partial) be required after Diamond Grinding (Bridge Section).

The actual sizes and locations of patching shall be determined by the engineer. The Engineer shall show the actual locations of the deck repairs on this sheet.

BILL OF MATERIAL

Structure	Item	Unit	Total
020-0028	Deck Slab Repair (Partial Depth)	Sq Yd	5.0
020-0029	Deck Slab Repair (Partial Depth)	Sq Yd	5.0

MODEL: \\MODEL\MNMF5
 FILE: \\MAILS_PUB\Public\paw_bec@paw.com\FW\DOT\Documents\DOT_Offices\Dir\dr: S:\Project\057028\CAD\Drawings\CAD\Drawings\057028\EB-Plan-020-0028-0029.dgn

USER NAME = erik.shawler	DESIGNED -	REVISED -
	DRAWN -	REVISED -
PLOT SCALE = 40,0000 * / in.	CHECKED -	REVISED -
PLOT DATE = 11/29/2022	DATE -	REVISED -

**STATE OF ILLINOIS
DEPARTMENT OF TRANSPORTATION**

**PARTIAL DEPTH PATCHING DETAIL (DECK)
S.N. 020-0028 (EB) & S.N. 020-0029 (WB)**

SCALE: SHEET 5 OF 6 SHEETS STA. TO STA.

F.A.I. RTE.	SECTION	COUNTY	TOTAL SHEETS	SHEET NO.
74	MBPM 2023-1	DE WITT	28	23
ILLINOIS FED. AID PROJECT			CONTRACT NO. 70G28	

PARTIAL DEPTH PATCHING DETAILS (APPROACH)

S.N. 020-0028 (EB) & S.N. 020-0029 (WB)

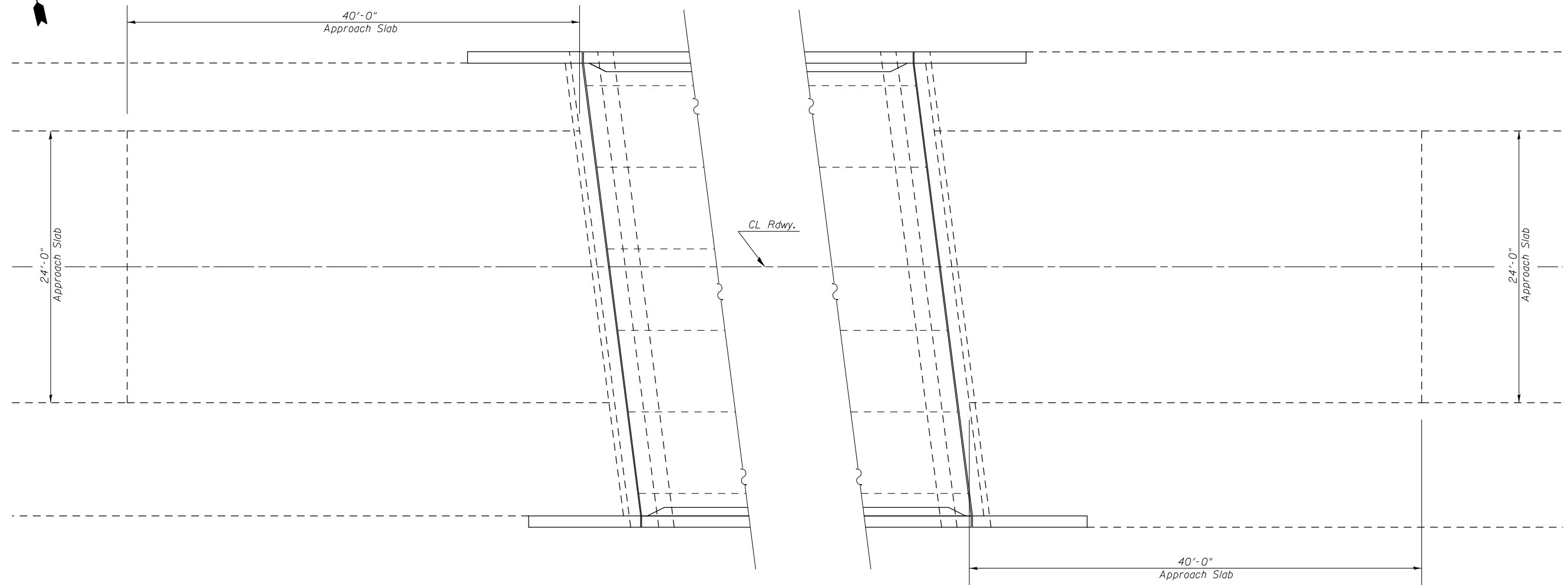

PLAN VIEW
Similar Each Structure

PLAN VIEW
Similar Each Structure

NOTES:

An Estimated 1% of the Deck Area has been included should additional Deck Slab Repair (Partial) be required after Diamond Grinding (Bridge Section).

The actual sizes and locations of patching shall be determined by the engineer. The Engineer shall show the actual locations of the deck repairs on this sheet.

BILL OF MATERIAL

Structure	Item	Unit	Total
020-0028	Approach Slab Repair (Partial Depth)	Sq Yd	2.5
020-0029	Approach Slab Repair (Partial Depth)	Sq Yd	2.5

MODEL: I:\MODEL\MATF...
 FILE: MATF...
 PROJECT: I:\PROJECTS\DOT...
 DATE: 11/29/2022

USER NAME = erik.shawler	DESIGNED -	REVISED -	
	DRAWN -	REVISED -	
PLOT SCALE = 40,0000 * / in.	CHECKED -	REVISED -	
PLOT DATE = 11/29/2022	DATE -	REVISED -	

**STATE OF ILLINOIS
DEPARTMENT OF TRANSPORTATION**

**PARTIAL DEPTH PATCHING DETAIL (APPROACH)
S.N. 020-0028 (EB) & S.N. 020-0029 (WB)**

SCALE: SHEET 6 OF 6 SHEETS STA. TO STA.

F.A.I. RTE.	SECTION	COUNTY	TOTAL SHEETS	SHEET NO.
74	MBPM 2023-1	DE WITT	28	24
ILLINOIS FED. AID PROJECT			CONTRACT NO. 70G28	

DESIGNER NOTE: PROVIDE MAP WITH SIGN LOCATIONS (A, B, ETC.) AND COORDINATE WITH TRAFFIC OPERATIONS ENGINEER.

INCLUDE DISTRICT SPECIAL PROVISION "WIDTH RESTRICTION SIGNING"

MODEL: \\MODELS\MNMF5
FILE: \\MAILS_P\public\paw_bendley.com\FW\DOT\Documents\DOT_offices\District_5\Project\0570G28\CAD\Drawings\0570G28-Plt-Width-Restriction.dgn

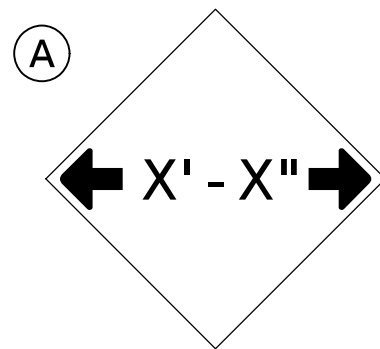

W12-2(O)-48"x48"(1200x1200)

SIGN (A) 2 SIGNS - W12-2(O)-48"x48"(1200x1200) ARE TO BE PLACED AS SHOWN IN THE PLANS OR AS DIRECTED BY THE ENGINEER.

SIGN (B) 2 SIGNS - (SIGN PANEL, TYPE II) AS SHOWN ARE TO BE PLACED AS SHOWN IN THE PLANS OR AS DIRECTED BY THE ENGINEER.

STAGE WIDTHS:

STAGE 1 WIDTH = 13' - 3" actual; 11' - 9" posted; REQUIRED
STAGE 2 WIDTH = 18' - 9" actual; POSTING NOT REQUIRED

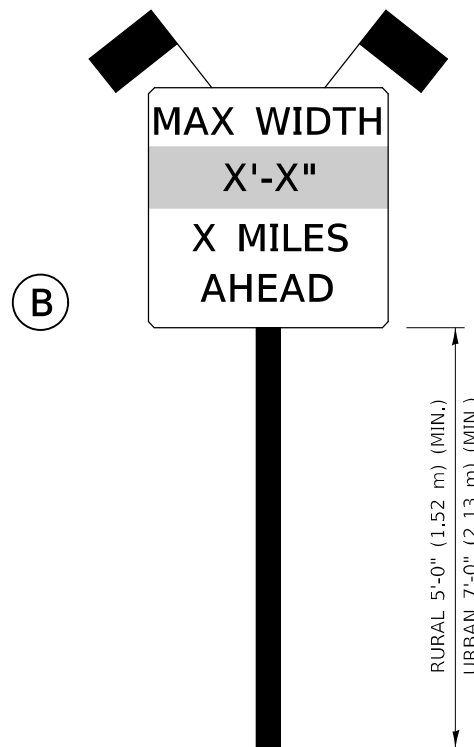

SIGN PANEL, TYPE II

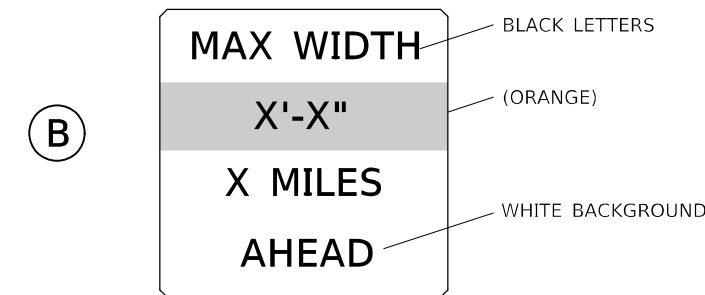

**W12-I103(O)-48"x48"(1200x1200)
"D" LETTERS/NUMBERS**

GENERAL NOTES

1. ALL TRAFFIC CONTROL DEVICES SHALL BE FURNISHED, ERECTED AND MAINTAINED BY THE CONTRACTOR.
2. ALL (B) SIGNS SHALL HAVE FLAGS INSTALLED UNLESS OTHERWISE DIRECTED.
3. LOCATIONS OF TRAFFIC CONTROL DEVICES MAY BE ADJUSTED BY THE ENGINEER.
4. ALL TRAFFIC CONTROL SHOWN ON THIS SHEET SHALL BE PAID FOR AT THE CONTRACT LUMP SUM PRICE FOR WIDTH RESTRICTION SIGNING.
5. ALL SIGNS SHALL BE POST MOUNTED UNLESS OTHERWISE DIRECTED.
6. ALL SIGNS SHOWN ORANGE (O) SHALL BE FLUORESCENT ORANGE.
7. ALL SIGNS SHOWN SHALL CONSIST OF THE CURRENT RETROREFLECTIVE SHEETING REQUIREMENTS AS OUTLINED IN SECTION 1106.01 OF THE STANDARD SPECIFICATIONS BOOK.

Note: All dimensions are in INCHES (millimeters) unless otherwise shown.

DISTRICT 5 DETAIL NO. X7200201

USER NAME = erik.shawler	DESIGNED -	REVISED - 05/08
	DRAWN -	REVISED - 10/08 KJT
PLOT SCALE = 40,0000 * / in.	CHECKED -	REVISED - 07/09 KJT
PLOT DATE = 11/29/2022	DATE -	REVISED - 03/11 KJT

**STATE OF ILLINOIS
DEPARTMENT OF TRANSPORTATION**

WIDTH RESTRICTION SIGNING

SCALE: SHEET 1 OF 2 SHEETS STA. TO STA.

F.A.I. RTE.	SECTION	COUNTY	TOTAL SHEETS	SHEET NO.
74	MBPM 2023-1	DE WITT	28	25
			CONTRACT NO. 70G28	
			ILLINOIS FED. AID PROJECT	

WIDTH RESTRICTION SIGNING FOR STRUCTURE REPAIRS WEST OF FARMER CITY INTERCHANGE

FAI 74 / US 136 INTERCHANGE

- B1
NORTHWEST OF FAI74/US136 INTERCHANGE
ERECT NEAR HEYWORTH/RANTOUL 1/2 MILE
GREENBOARD DUAL DISPLAY; 6 MILES AHEAD
6 MILE
- A1
WEST OF FAI74/US136 INTERCHANGE ON US 136
ERECT 150FT PRIOR TO EB ON RAMP BY GREENBOARD
INCLUDE RIGHT ARROW SIGN BELOW WIDTH SIGN
→
- A2
WEST OF FAI74/US136 INTERCHANGE ON US 136
ERECT 100FT PRIOR TO EB ON RAMP
INCLUDE LEFT ARROW SIGN BELOW WIDTH SIGN
←

FARMER CITY INTERCHANGE

- B2
SOUTHEAST OF FARMER CITY INTERCHANGE
ERECT NEAR FARMER CITY 1/2 MILE GREENBOARD
DUAL DISPLAY; 2 MILES AHEAD
2.0 MILE
- A3
NORTH OF FARMER CITY INTERCHANGE ON IL54
ERECT 200FT PRIOR TO WB ON RAMP
INCLUDE RIGHT ARROW SIGN BELOW WIDTH SIGN
→
- A4
SOUTH OF FARMER CITY INTERCHANGE ON IL54
ERECT 150FT PRIOR TO WB ON RAMP BY 45MPH SIGN
INCLUDE LEFT ARROW SIGN BELOW WIDTH SIGN
←

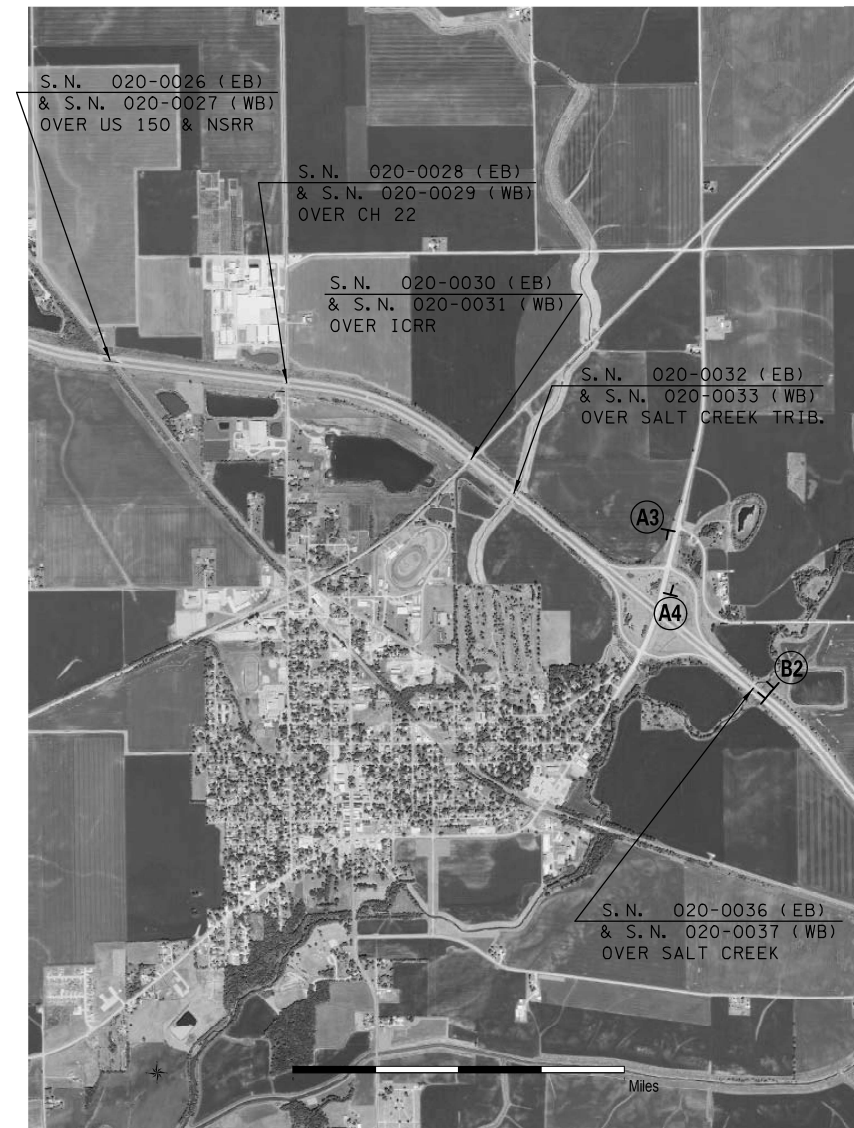

MODEL: \\MODEL\MAMFE
 FILE: \\MAILS_PUB\pub\shawler\com\PI\DOT\Documents\DOT_Offices\Dir\dir: S:\Project\0570228\CAD\DATA\CAD\Sheets\0570228-sh-Width-Restriction.dgn

USER NAME = erik.shawler	DESIGNED -	REVISED -	
	DRAWN -	REVISED -	
PLOT SCALE = 100,0000' / in.	CHECKED -	REVISED -	
PLOT DATE = 11/29/2022	DATE -	REVISED -	

**STATE OF ILLINOIS
DEPARTMENT OF TRANSPORTATION**

WIDTH RESTRICTION SIGNING			
S.N. 020-0026 (EB) S.N. 020-0027 (WB)			
SCALE:	SHEET 2 OF 2 SHEETS	STA.	TO STA.

F.A.I. RTE.	SECTION	COUNTY	TOTAL SHEETS	SHEET NO.
74	MBPM 2023-1	DE WITT	28	26
CONTRACT NO. 70G28				
ILLINOIS FED. AID PROJECT				

DETAIL FOR TEMPORARY RUMBLE STRIPS (SPECIAL)

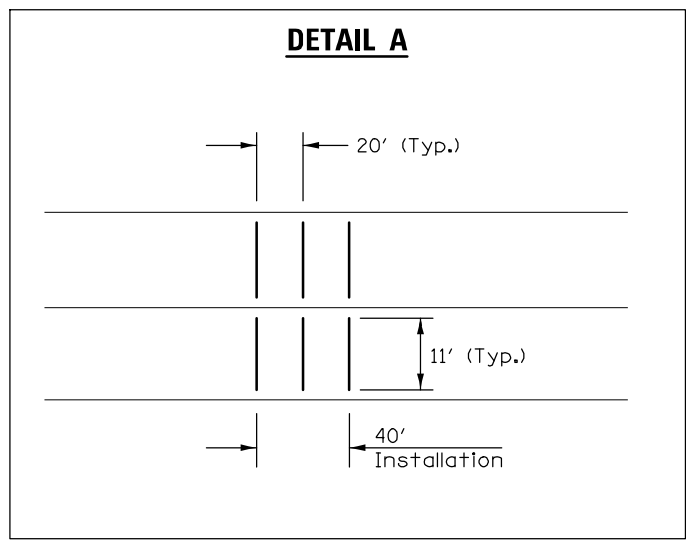
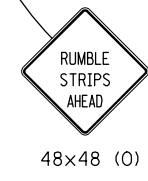
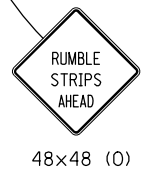
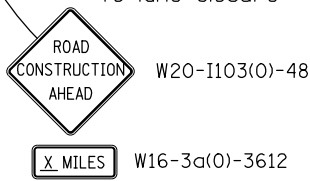
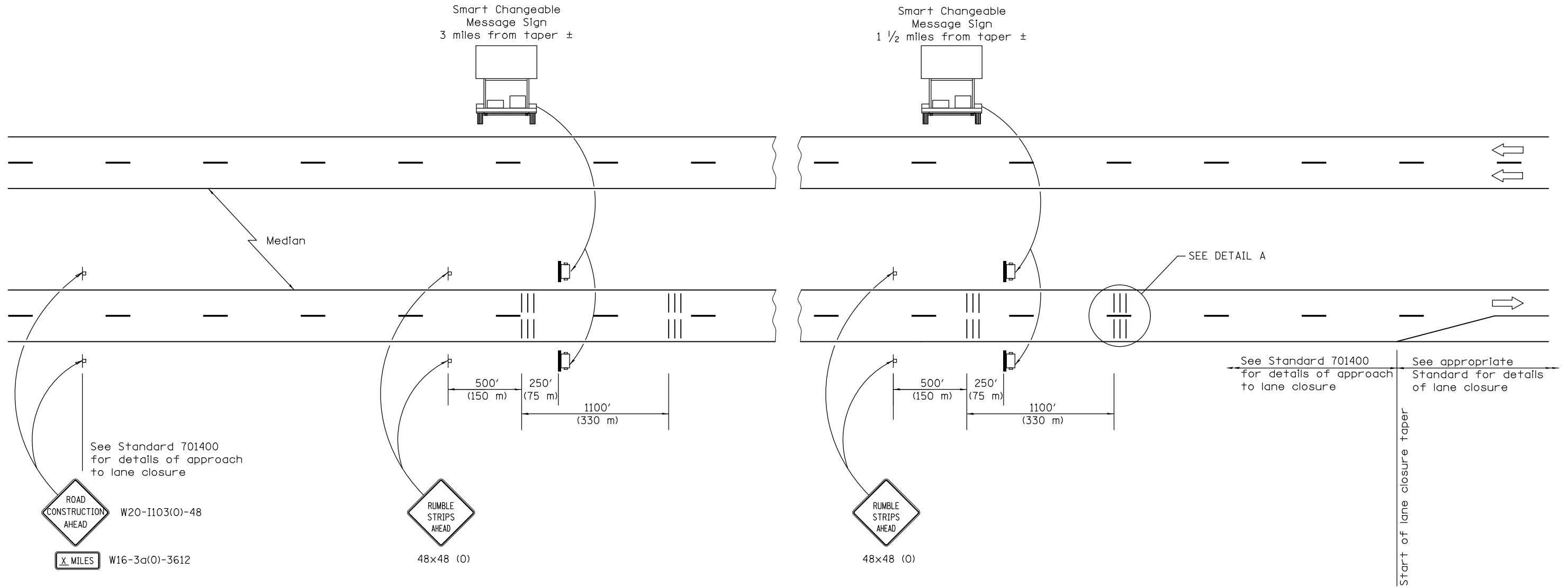

SYMBOLS

- ▬ Sign
- ||| Temporary Rumble Strips (Special)
- ☛ Trailer Mounted Sign

GENERAL NOTES

Remove the Temporary Rumble Strips (Special) prior to the removal of the advanced warning signs.

All dimensions are in inches (millimeters) unless otherwise shown.

MODEL: I:\MODEL\MMF5
 FILE: MMF5.dwg
 PLOT DATE: 11/29/2022
 PROJECT: I:\PROJECTS\70G28\CADD\DATA\CAD\FILES\70G28-PL-11818-RESTRIP.dgn

USER NAME = erik.shawler	DESIGNED -	REVISED -
PLOT SCALE = 40,0000 * / in.	DRAWN -	REVISED -
PLOT DATE = 11/29/2022	CHECKED -	REVISED -
	DATE -	REVISED -

**STATE OF ILLINOIS
DEPARTMENT OF TRANSPORTATION**

DETAIL FOR TEMPORARY RUMBLE STRIPS (SPECIAL)

SCALE: SHEET 1 OF 1 SHEETS STA. TO STA.

F.A.I. RTE.	SECTION	COUNTY	TOTAL SHEETS	SHEET NO.
74	MBPM 2023-1	DE WITT	28	27
CONTRACT NO. 70G28				
ILLINOIS FED. AID PROJECT				

CENTERLINE INTERSTATE OR MULTI-LANE TWO WAY DIVIDED HIGHWAY

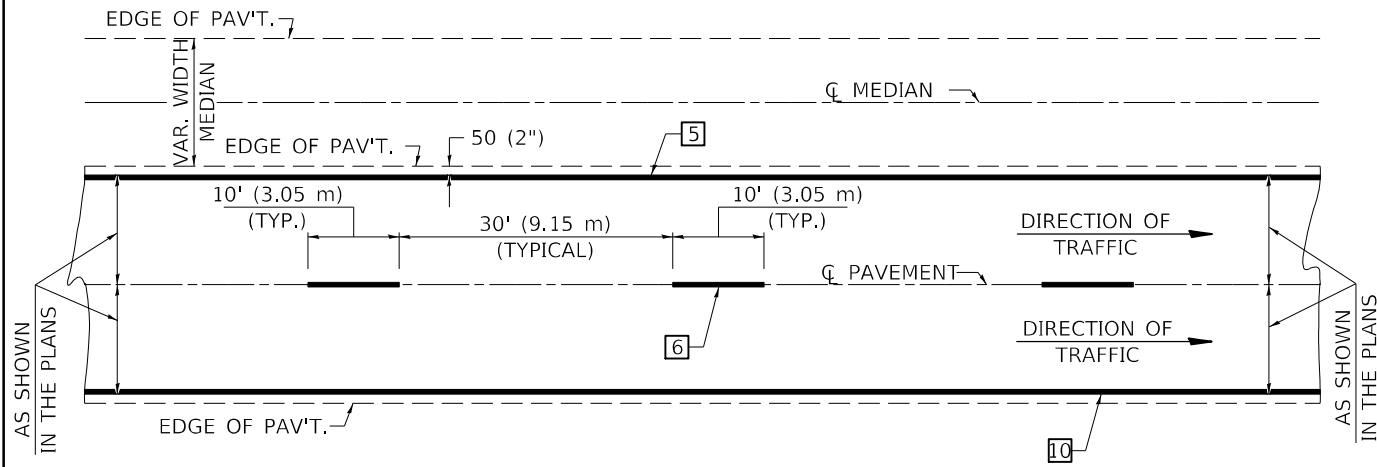

NOTE: PAVEMENT MARKINGS ARE TO BE EXTENDED THROUGH OMISSIONS WHEN APPLICABLE.

NOTE: SEE ARTICLES 780.04 & 781.03 FOR LOCATION OF STRIPES AND MARKERS RELATIVE TO EDGES OR JOINTS.

FOR RAISED REFLECTIVE PAVEMENT MARKERS, REFER TO STANDARD 781001.

TYPICAL PAVEMENT MARKING LEGEND

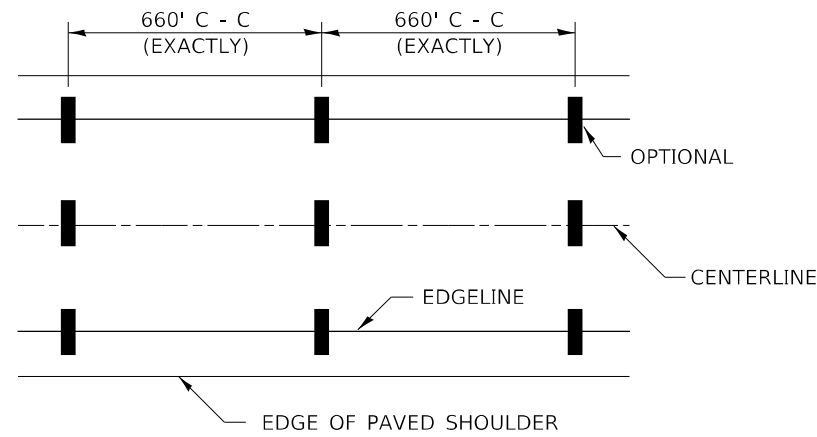

- 1 4" (100) SKIP-DASH (YELLOW)
- 2 4" (100) SOLID (YELLOW)
- 3 12" (300) DIAGONAL (YELLOW)
- 4 4" (100) DOUBLE YELLOW (NARROW)
- 5 6" (150) SOLID (YELLOW)
- 6 6" (150) SKIP-DASH (WHITE)
- 7 4" (100) SKIP-DASH (WHITE)
- 8 4" (100) SOLID (WHITE)
- 9 12" (300) DIAGONAL (WHITE)
- 10 6" (150) SOLID (WHITE)
- 11 24" (600) STOP BAR (WHITE)
- 12 8" (200) SOLID (WHITE)
- 13 6" (150) LANE LINE EXTENSIONS (WHITE)

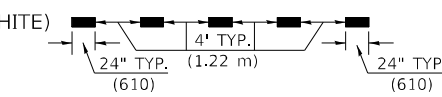
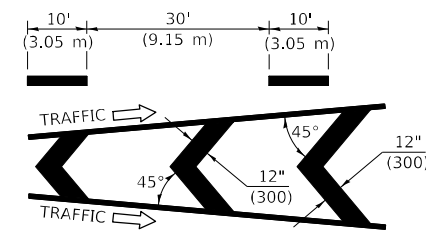
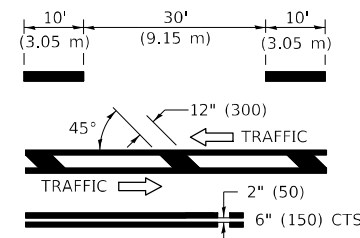

TYPICAL EXIT RAMP TERMINAL

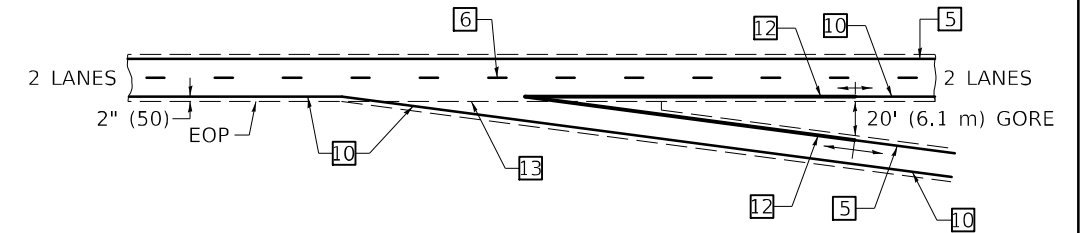

EXIT RAMP TERMINAL with EXCLUSIVE (auxiliary) LANE

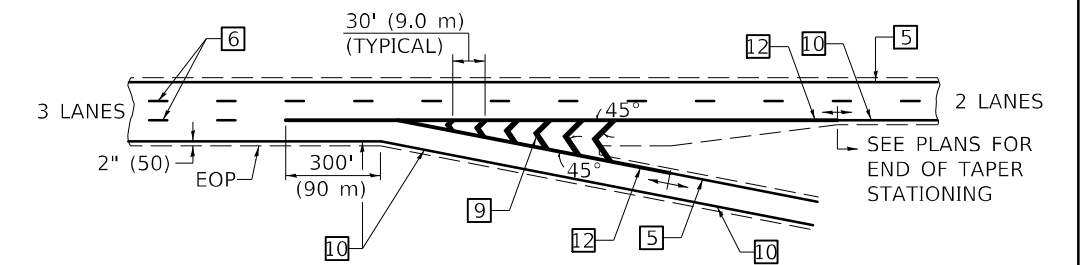

TYPICAL ENTRANCE RAMP TERMINAL

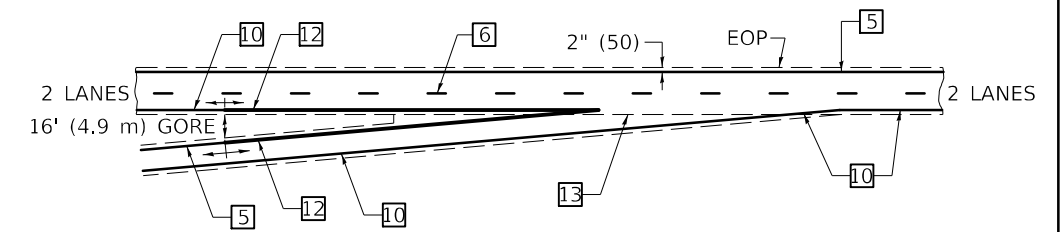

ENTRANCE RAMP TERMINAL with EXCLUSIVE LANE

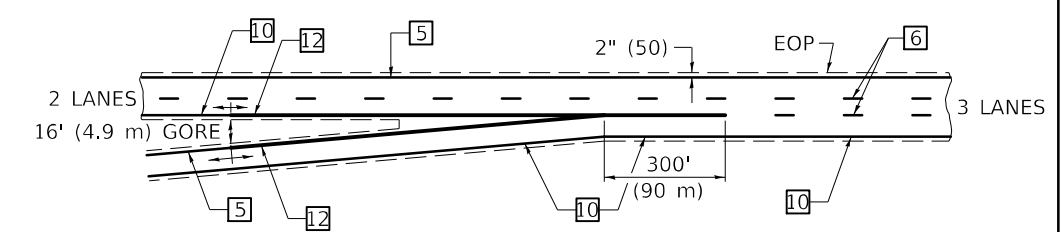

IT WILL BE NECESSARY TO HAVE A REPRESENTATIVE OF THE STATE POLICE PRESENT SO THAT THE ACCURACY OF MEASUREMENT CAN BE ATTESTED TO IN COURT.

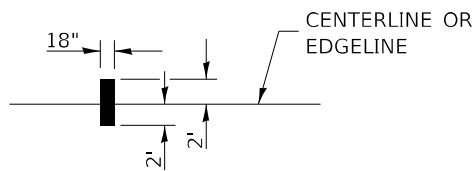

AERIAL SPEED CHECK ZONES

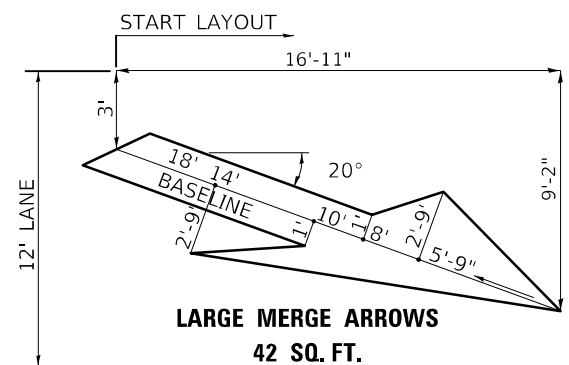

Note: All dimensions are in INCHES (millimeters) unless otherwise shown.

DISTRICT 5 DETAIL NO. 7800BBBB

USER NAME = erik.shawler	DESIGNED -	REVISED - 11/06
	DRAWN -	REVISED - 12/20
PLOT SCALE = 40,0000 * / in.	CHECKED -	REVISED -
PLOT DATE = 11/29/2022	DATE -	REVISED -

**STATE OF ILLINOIS
DEPARTMENT OF TRANSPORTATION**

PAVEMENT MARKING (INTERSTATE & MULTI-LANE APPLICATIONS)

SCALE: SHEET 1 OF 1 SHEETS STA. TO STA.

F.A.I. RTE.	SECTION	COUNTY	TOTAL SHEETS	SHEET NO.
74	MBPM 2023-1	DE WITT	28	28
CONTRACT NO. 70G28				
ILLINOIS FED. AID PROJECT				

MODEL: I:\MODEL\MBPM\FIELD\MBPM\DOT\Documents\DOT\Office\Drawings\Project\70G28\CADD\Drawings\70G28-PL-11818b-detailed.dgn