

EXISTING TYPICAL SECTION FOR RAMPS

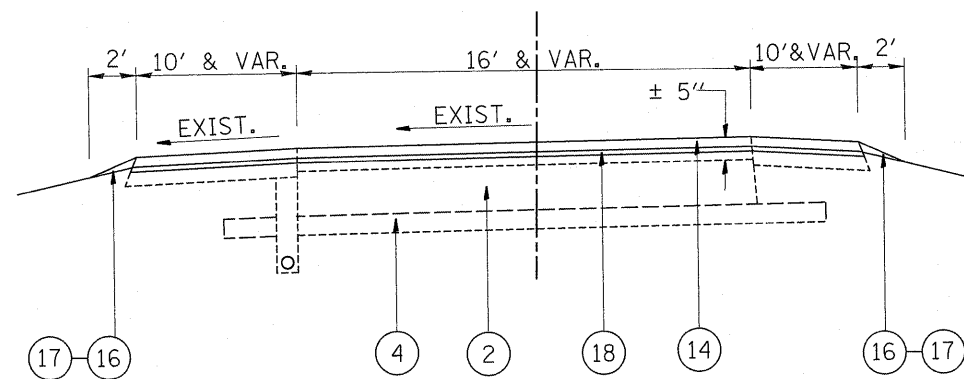

PROPOSED TYPICAL SECTION FOR RAMPS

**NOTE:**

- CONTRACTOR SHALL MILL BEFORE PATCHING ON RAMPS

**LEGEND**

- ① EXISTING HOT-MIX ASPHALT SURF. CSE., ± 5"
- ② EXISTING P.C.C. PAVEMENT, 10"
- ②A EXISTING HOT-MIX ASPHALT SURFACE AFTER MILLING, ± 2 3/4"
- ③ EXISTING SUB-BASE GRAN. MATL., 4"
- ④ EXISTING AGGREGATE SUBGRADE, 12"
- ⑤ EXISTING HOT-MIX ASPHALT SHOULDER
- ⑥ EXISTING CONC. BINDER CSE. MIX B, TYPE 1
- ⑥A EXISTING PIPE UNDERDRAIN
- ⑦ EXISTING AGGREGATE SHOULDER TYPE "B"
- ⑦A EXISTING CONC BARRIER WALL DOUBLE FACE (2'-3' WIDE)
- ⑧ PROPOSED HOT-MIX ASPHALT SURFACE REMOVAL, 2 1/4" (RAMPS)
- ⑨ PROPOSED HOT-MIX ASPHALT SURFACE REMOVAL, 4" (MAINLINE)
- ⑩ PROPOSED HOT-MIX ASPHALT SURFACE REMOVAL, 3 3/4" (OUTSIDE & INSIDE SHOULDER)
- ⑪ PROPOSED POLYMERIZED HOT-MIX ASPHALT BINDER COURSE, STONE MATRIX ASPHALT, N80, 2"
- ⑫ PROPOSED POLYMERIZED HOT-MIX ASPHALT SURFACE COURSE, STONE MATRIX ASPHALT, N80, 2"
- ⑬ PROPOSED HOT-MIX ASPHALT BINDER COURSE, IL-19, N70, 2 1/4"
- ⑭ PROPOSED HOT-MIX ASPHALT SURFACE COURSE, MIX. "D", N70, 1 1/2"
- ⑮ PROPOSED SHOULDER RUMBLE STRIP
- ⑯ PROPOSED AGGREGATE WEDGE SHOULDER, TYPE "B"
- ⑰ PROPOSED GRADING AND SHAPING SHOULDER
- ⑱ PROPOSED POLYMERIZED LEVELING BINDER, IL-4.75, N50, 3/4"

FILE NAME =	USER NAME = qureshya	DESIGNED -	REVISED -	<b>STATE OF ILLINOIS DEPARTMENT OF TRANSPORTATION</b>	<b>IL. ROUTE 55 TYPICAL SECTION FOR RAMPS</b>	F.A.1	SECTION	COUNTY	TOTAL	SHEET	
ct:\pwork\p\dot\qureshya\d0187440\DI1310-ahp-plan.dgn	DRAWN -	REVISED -	55			.	COOK	197	7		
PLOT SCALE = 52.9406' / IN.	CHECKED -	REVISED -	CONTRACT NO. 60164								
PLOT DATE = 1/3/2011	DATE -	REVISED -	ILLINOIS FED. AID PROJECT								
					SCALE:	SHEET NO. 1 OF 1 SHEETS	STA.	TO STA.	ILLINOIS FED. AID PROJECT		