

PLAN

BILL OF MATERIAL

ITEM	UNIT	TOTAL
Deck Slab Repair (Full Depth, Type I)	Sq. Yd.	5
Deck Slab Repair (Full Depth, Type II)	Sq. Yd.	5
Deck Slab Repair (Partial)	Sq. Yd.	27
Silicone Joint Sealer, 1 3/4"	Foot	45
Silicone Joint Sealer, 2 1/2"	Foot	45

LEGEND:

- Deck Slab Repair (Partial)
- Deck Slab Repair (Full Depth, Type I)
- Deck Slab Repair (Full Depth, Type II)

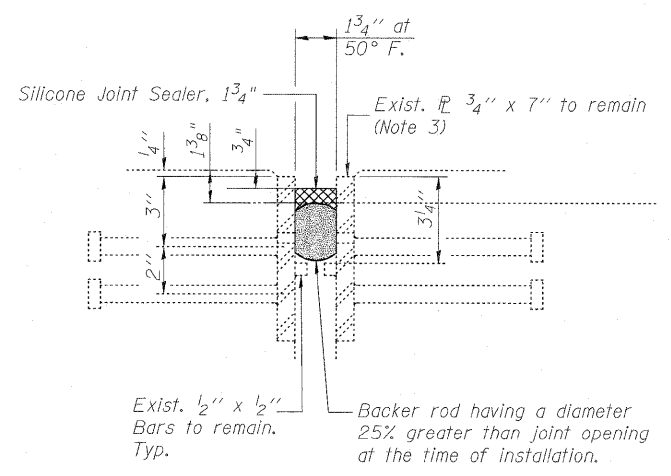

SECTION A-A
(At West Abutment)

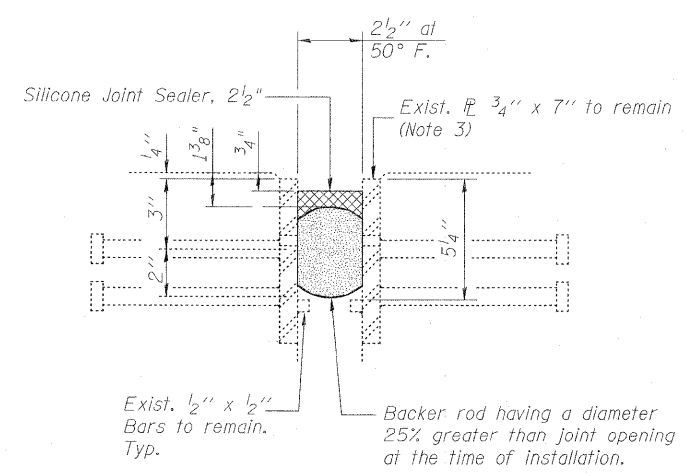

SECTION B-B
(At East Abutment)

DECK EXPANSION JOINT DETAILS

- Notes:
- See General Note 4 on Sheet S1 of S6.
 - Removal and disposal of the existing joint fillers will be included with the cost of Silicone Joint Sealer, of the size specified.
 - Existing plates to be cleaned prior to installation of backer rod. Cost included with Silicone Joint Sealer, of the size specified.

USER NAME = e:\proj\cadd\l\rdwy\l131e\	DESIGNED - A.Y./L.C.	REVISED -		STATE OF ILLINOIS DEPARTMENT OF TRANSPORTATION	DECK AND EXPANSION JOINT REPAIRS EASTBOUND I-80 OVER MIDLAND AVENUE SN 099-0050		F.A.I. RTE. 80	SECTION 99 (2&3) RS-3	COUNTY WILL	TOTAL SHEETS 200	SHEET NO. 93
PLOT CONFIG = PDFI-B1_TopoGrey_Large.plt	DRAWN - L.C./A.Y.	REVISED -			SCALE: SHEET S3 OF S6	STA. TO STA.	CONTRACT NO. 60M64		FED. ROAD DIST. NO. 1 [ILLINOIS] FED. AID PROJECT		
PLOT SCALE = 1:10	CHECKED - A.Y./R.L.D.	REVISED -									
PLOT DATE = 2/8/2011	DATE - 01/21/2011	REVISED -									

q:\dot\21050.005 (I-80 phase 1)\drawings\cadd sheets\bridge p&e\midland\eb\099-0050-0160M64-Deck-Midland.dgn