

**PPC I-BEAMS AND BULB-T'S**

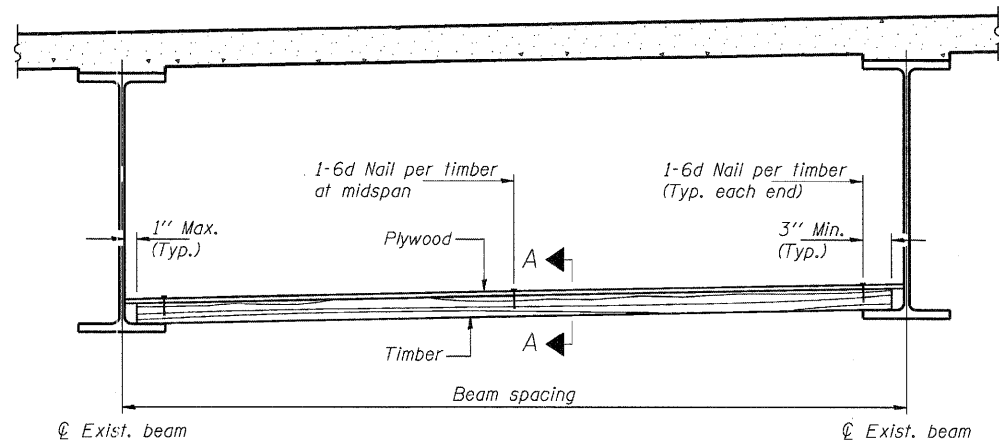

**STEEL BEAMS**

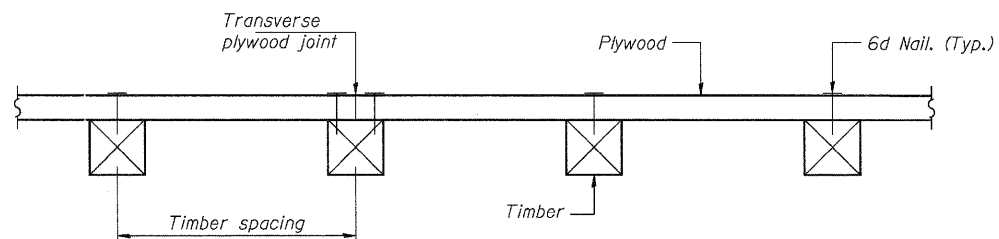

**SECTION A-A**

**TIMBER SPACING**

Beam Spacing (ft.)	Timber Sizes (in.)		
	4" x 4" with min. Fb=775 psi Fv=135 psi	4" x 6" with min. Fb=775 psi Fv=135 psi	6" x 6" with min. Fb=575 psi Fv=125 psi
	Maximum Timber Spacing (in.)		
4.5	16	16	16
4.75	16	16	16
5.0	16	16	16
5.25	16	16	16
5.5	16	16	16
5.75	16	16	16
6.0	16	16	16
6.25	12	16	16
6.5	12	16	16
6.75	12	16	16
7.0	8	16	16
7.25	8	16	16
7.5	8	16	16
7.75	8	16	16
8.0	8	12	16
8.25	8	12	16
8.5	6	12	12
8.75	6	12	12
9.0	6	8	12

**PPC I-BEAMS AND BULB-T'S**

BEAM	"A"
36" I-Beam	1 1/2"
42" I-Beam	1 1/2"
48" I-Beam	1 1/2"
54" I-Beam	1 5/8"
63" Bulb-T	3 3/8"
72" Bulb-T	3 3/8"

Notes: See special provision for Protective Shield, Special.  
 Timber sizes shown are nominal sizes. Rough sawn timber of the dimensions shown will also be considered acceptable.  
 The minimum Fb and Fv values shown are the tabulated design values given in the National Design Specification for Wood Construction for No. 2 Spruce-Pine-Fir without adjustment factors applied. Better grades or other species with equal or higher allowable stresses will also be considered acceptable.  
 The timber spacings shown have been determined using allowable stresses with all adjustment factors necessary for the anticipated service conditions.  
 All timber shall be treated.  
 Plywood shall be 5/8" Exterior type plywood per APA.  
 Plywood shall be placed such that the face grain is perpendicular to the timber supports. When less than a full sheet (4' width) of plywood is used, the width of the strip used shall not be less than 2'.  
 Transverse plywood joints shall be supported by timbers.  
 When 4" x 6" timbers are used, they shall be placed such that the wide face is horizontal and the narrow face is vertical.  
 Design load = 200 psf.

**BILL OF MATERIAL**

Item	Unit	Total
Protective Shield, (Permanent)	Sq. Yd.	360

USER NAME = Imjeller	DESIGNED - DF	REVISED -
PLOT SCALE = NIS	DRAWN - LAM	REVISED -
PLOT DATE = 1/20/2011 12:34:07 PM	CHECKED - BLU	REVISED -
	DATE - 01/21/2011	REVISED -



**STATE OF ILLINOIS  
DEPARTMENT OF TRANSPORTATION**

**PROTECTIVE SHIELD, SPECIAL  
EASTBOUND FAI-80 OVER CENTER STREET RAMP CC  
STRUCTURE NO. 099-0055**

F.A.I. RTE. 80	SECTION 99(2&3)RS-3	COUNTY WILL	TOTAL SHEETS 200	SHEET NO. 106
FED. ROAD DIST. NO. ILLINOIS FED. AID PROJECT			CONTRACT NO. 60M64	