

ELEVATION

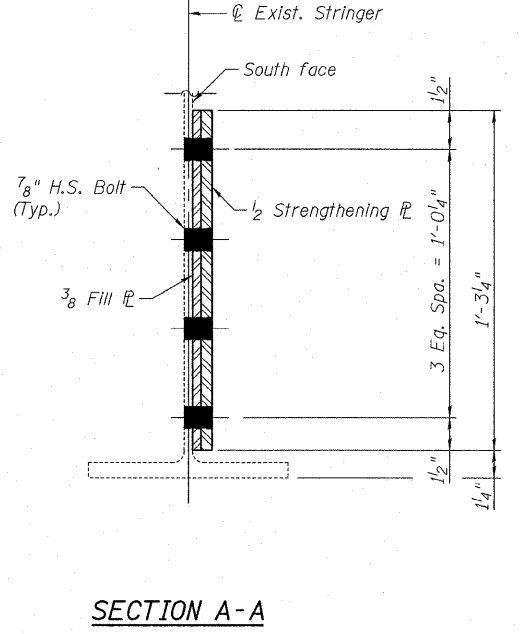

SECTION A-A

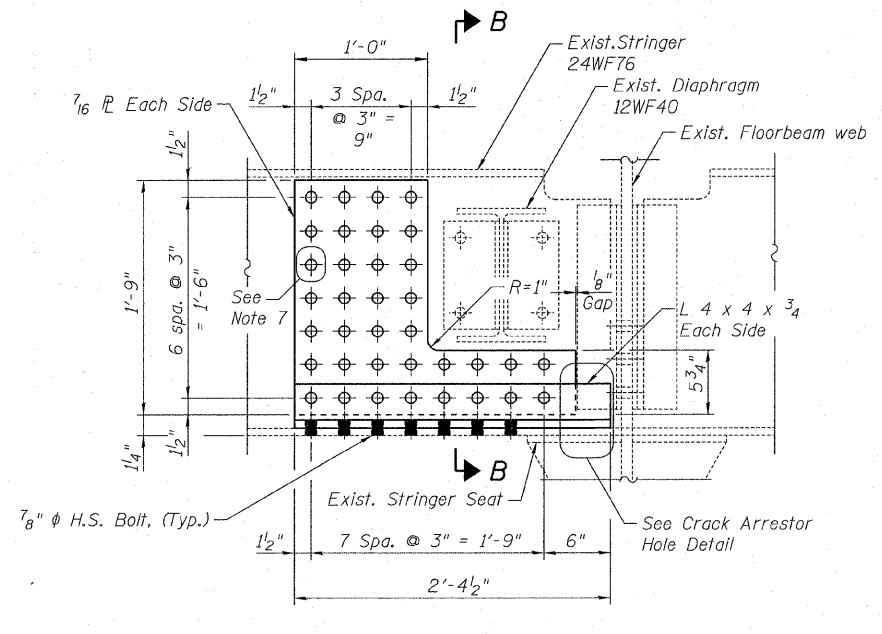

ELEVATION

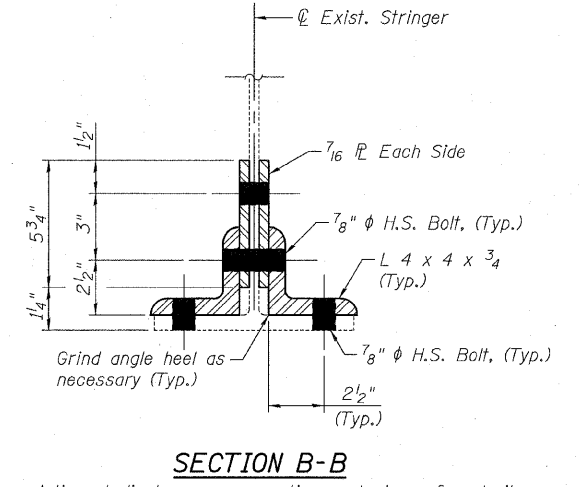

SECTION B-B

Adjacent diaphragms, connections not shown for clarity

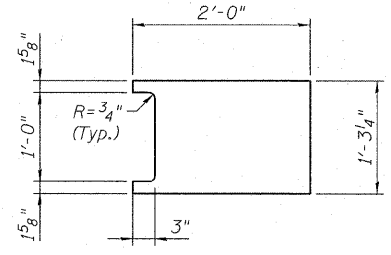

FILL PLATE

DETAIL 5
STRINGER WEB REPAIR

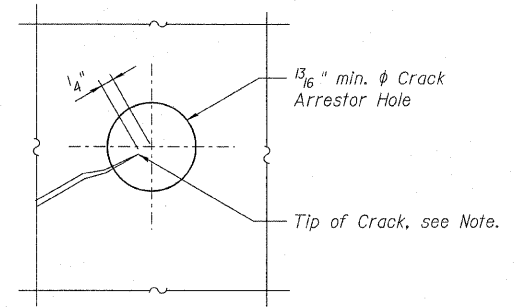

CRACK ARRESTOR HOLE DETAIL

Note: Locate crack tip using liquid dye penetrant or magnetic particle testing. Drill 1/16" min. dia. Crack Arrestor hole at the crack tip. After crack arrestor hole has been drilled, dye penetrant or magnetic particle testing shall be used for verify that the drilled hole has captured the crack tip. Cost shall be included in the cost of "Structural Steel Repair". Provide crack arrestor hole at all cracks without one prior to installation of strengthening plates.

DETAIL 7
STRINGER WEB AND FLANGE REPAIR 4

NOTES:

- See Sheets S-8 to S-14 of 35 for locations of proposed repair details and notes.
- All structural steel plates and shapes used in proposed repair details shall be AASHTO M270 Gr 36 (ASTM A36).
- All fasteners shall be 7/8" dia. AASHTO M164 (ASTM A325) high strength bolts in 15/16" dia. standard size holes unless otherwise noted.
- Contact surfaces at bolted parts shall have Class B coating as specified in AASHTO Standard Specifications for Highway Bridges.
- Field drilling of existing members is required. The drilling cost shall be included with "Structural Steel Repair".
- The repair plate and shape lengths shown are anticipated based on the latest field notes. Longer repair plates, shapes may be required based upon field conditions.
- 15/16" phi standard size holes in the stringer web are to be field drilled using the repair plates and shapes as template except as noted.
- Use existing connection angle to drill holes in the repair plate. Remove and replace existing bolts/rivets with 7/8" phi H.S. bolts.
- Suggested repair installation procedure:
 - Remove existing bolts/rivets and install construction pins in their place. No more than one hole shall be kept without a bolt/rivet or pin during this process.
 - Position the repair plates over the area to be repaired.
 - Remove the construction pins. As each construction pin is removed, install a 7/8" phi H.S. bolt and tighten it to snug fit.
 - When the repair is properly positioned and existing rivets/bolts have been replaced with H.S. bolts, field drill 15/16" phi holes through undersized 15/16" phi holes in the repair plates and the existing web plate/angle, as shown, and install 7/8" phi H.S. bolts.
 - After all of the H.S. bolts have been installed in the repair, begin tightening of the bolts. Start at the top of the repair plates and proceed across and down until all H.S. bolts are tightened as specified.

DESIGNED - MEA	REVISED -
DRAWN - LK	REVISED -
CHECKED - MRI	REVISED -
DATE - 2/8/2011	REVISED -



STATE OF ILLINOIS
DEPARTMENT OF TRANSPORTATION

STEEL REPAIR DETAILS 3
EASTBOUND FAI-80 OVER DES PLAINES RIVER
STRUCTURE NO. 099-0056
SHEET NO. S-17 OF 35 SHEETS

F.A.I. RTE.	SECTION	COUNTY	TOTAL SHEETS	SHEET NO.
80	99 (2&3) RS-3	WILL	200	124
CONTRACT NO. 60M64				
FED. ROAD DIST. NO. 1 ILLINOIS FED. AID PROJECT				