

PPC I-BEAMS AND BULB-T'S

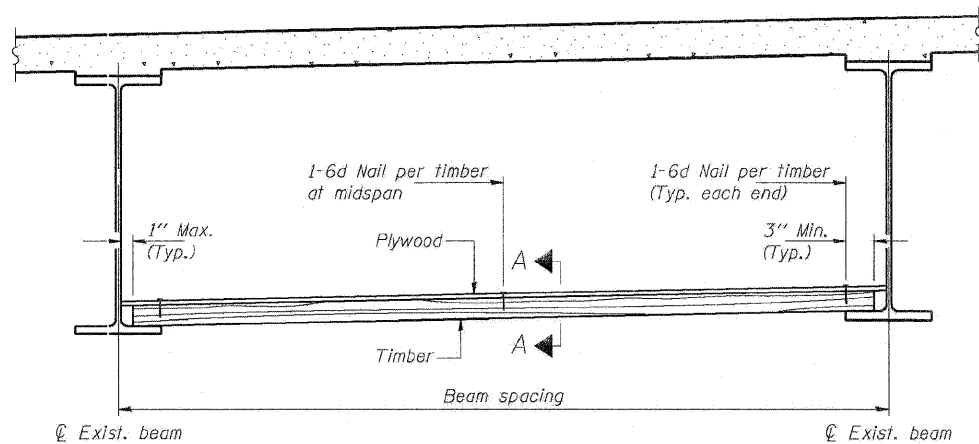

STEEL BEAMS

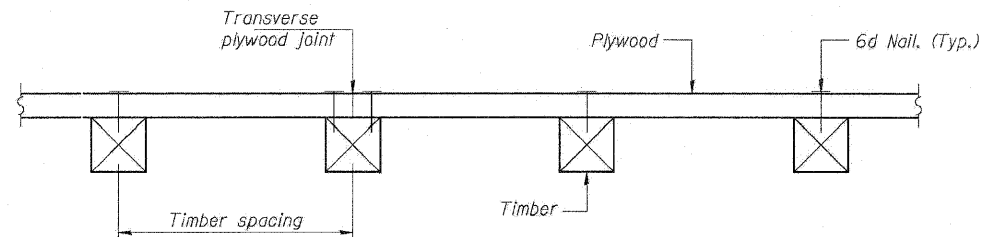

SECTION A-A

TIMBER SPACING

Beam Spacing (ft.)	Timber Sizes (in.)		
	4" x 4" with min. Fb=775 psi Fv=135 psi	4" x 6" with min. Fb=775 psi Fv=135 psi	6" x 6" with min. Fb=575 psi Fv=125 psi
	Maximum Timber Spacing (in.)		
4.5	16	16	16
4.75	16	16	16
5.0	16	16	16
5.25	16	16	16
5.5	16	16	16
5.75	16	16	16
6.0	16	16	16
6.25	12	16	16
6.5	12	16	16
6.75	12	16	16
7.0	8	16	16
7.25	8	16	16
7.5	8	16	16
7.75	8	16	16
8.0	8	12	16
8.25	8	12	16
8.5	6	12	12
8.75	6	12	12
9.0	6	8	12

PPC I-BEAMS AND BULB-T'S

BEAM	"A"
36" I-Beam	1 1/2"
42" I-Beam	1 1/2"
48" I-Beam	1 1/2"
54" I-Beam	1 5/8"
63" Bulb-T	3 3/8"
72" Bulb-T	3 3/8"

Notes: See special provision for Permanent Protective Shield System.
 Timber sizes shown are nominal sizes. Rough sawn timber of the dimensions shown will also be considered acceptable.
 The minimum Fb and Fv values shown are the tabulated design values given in the National Design Specification for Wood Construction for No. 2 Spruce-Pine-Fir without adjustment factors applied. Better grades or other species with equal or higher allowable stresses will also be considered acceptable.
 The timber spacings shown have been determined using allowable stresses with all adjustment factors necessary for the anticipated service conditions.
 All timber shall be treated.
 Plywood shall be 5/8" Exterior type plywood (per American Plywood Association). Plywood shall be placed such that the face grain is perpendicular to the timber supports. When less than a full sheet (4' width) of plywood is used, the width of the strip used shall not be less than 2'.
 Transverse plywood joints shall be supported by timbers.
 When 4" x 6" timbers are used, they shall be placed such that the wide face is horizontal and the narrow face is vertical.
 Design load = 200 psf.

BILL OF MATERIAL

ITEM	UNIT	TOTAL
Protective Shield (Permanent)	Sq. Yd.	641

USER NAME = egericoglu(Rdwj.L111e)	DESIGNED - A.Y./L.C.	REVISED -
PLOT CONFIG = PDF(I-80_TopoGrey_Large).pl	DRAWN - L.C./A.Y.	REVISED -
PLOT SCALE = 1:16	CHECKED - A.Y./R.L.D.	REVISED -
PLOT DATE = 2/8/2011	DATE - 01/21/2011	REVISED -



STATE OF ILLINOIS
DEPARTMENT OF TRANSPORTATION

PERMANENT PROTECTIVE SHIELD
EASTBOUND I-80 OVER IL ROUTE 53 (CHICAGO STREET)
SN 099-0059

SCALE: SHEET 55 of 56 STA. TO STA.

F.A.I. RTE.	SECTION	COUNTY	TOTAL SHEETS	SHEET NO.
80	99 (2&3) RS-3	WILL	200	147
FED. ROAD DIST. NO. 1 ILLINOIS FED. AID PROJECT			CONTRACT NO. 60M64	