

STANDARD BAR SPLICER ASSEMBLY

| Bar size to be spliced | Minimum Lap Lengths | | | | |
|------------------------|---------------------|---------|---------|---------|---------|
| | Table 1 | Table 2 | Table 3 | Table 4 | Table 5 |
| 3, 4 | 1'-5" | 1'-11" | 2'-1" | 2'-4" | 2'-3" |
| 5 | 1'-9" | 2'-5" | 2'-7" | 2'-11" | 2'-10" |
| 6 | 2'-1" | 2'-11" | 3'-1" | 3'-6" | 3'-4" |
| 7 | 2'-9" | 3'-10" | 4'-2" | 4'-8" | 4'-6" |
| 8 | 3'-8" | 5'-1" | 5'-5" | 6'-2" | 5'-10" |
| 9 | 4'-7" | 6'-5" | 6'-10" | 7'-9" | 7'-5" |

- Table 1: Black bar, 0.8 Class C
- Table 2: Black bar, Top bar lap, 0.8 Class C
- Table 3: Epoxy bar, 0.8 Class C
- Table 4: Epoxy bar, Top bar lap, 0.8 Class C
- Table 5: Epoxy bar, Top bar lap, Class B

Threaded splicer bar length = min. lap length + 1/2" + thread length

* Epoxy not required on Bar Splicer Assembly components used in conjunction with black bars.

| Location | Bar size | No. assemblies required | Table for minimum lap length |
|------------------|----------|-------------------------|------------------------------|
| W. ABUT. DECK | #5 | 7 | 3 |
| W. ABUT. END DAM | #6 | 6 | 3 |
| E. ABUT. DECK | #5 | 7 | 3 |
| E. ABUT. END DAM | #6 | 6 | 3 |
| TOTAL | | 26 | |

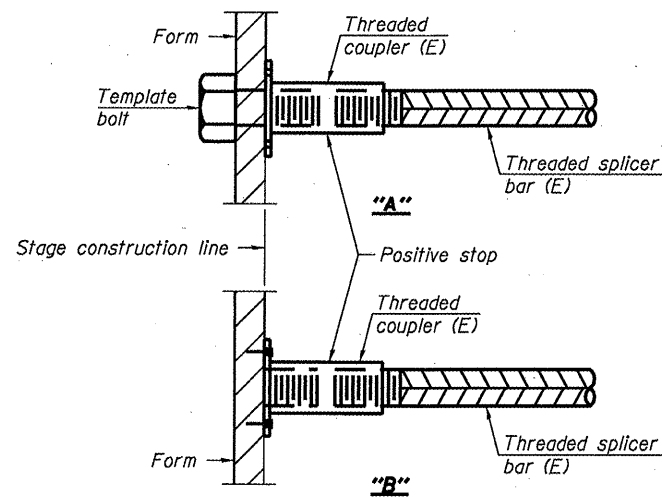

INSTALLATION AND SETTING METHODS

"A": Set bar splicer assembly by means of a template bolt.
 "B": Set bar splicer assembly by nailing to wood forms or cementing to steel forms.
 (E) : Indicates epoxy coating.

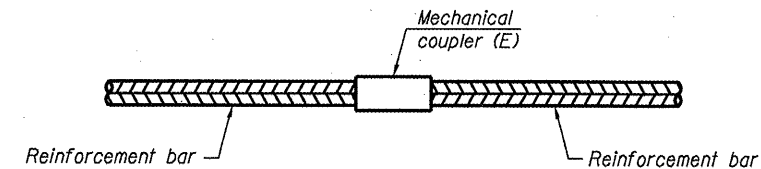

STANDARD MECHANICAL SPLICER

| Location | Bar size | No. assemblies required |
|----------|----------|-------------------------|
| | | |
| | | |
| | | |
| | | |

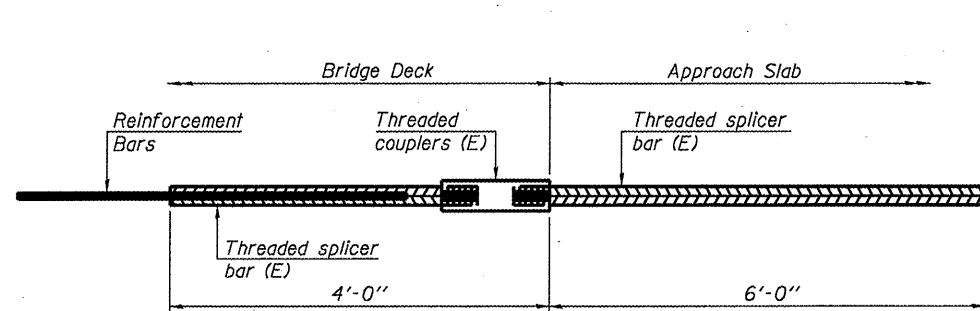

BAR SPLICER ASSEMBLY FOR #5 BAR ON INTEGRAL OR SEMI-INTEGRAL ABUTMENTS

No. required =

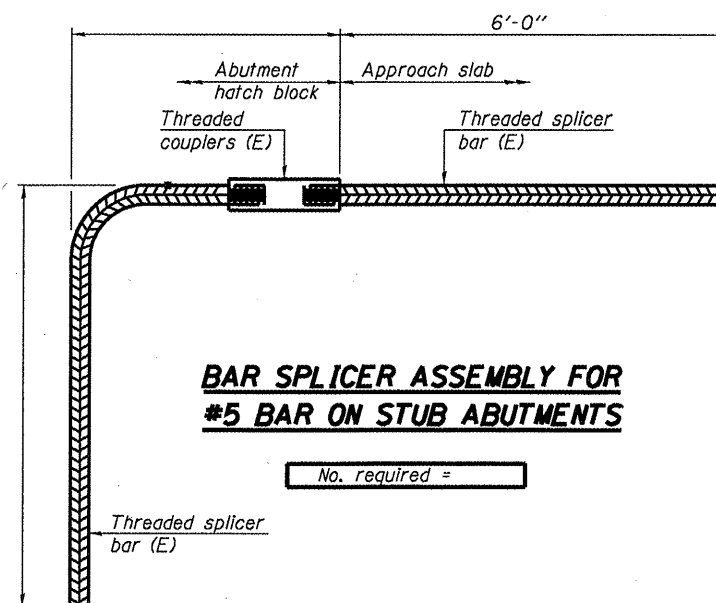

BAR SPLICER ASSEMBLY FOR #5 BAR ON STUB ABUTMENTS

No. required =

NOTES

Splicer bars shall be deformed with threaded ends and have a minimum 60 ksi yield strength.
 All reinforcement shall be lapped and tied to the splicer bars.
 Bar splicer assemblies shall be epoxy coated according to the requirements for reinforcement bars. See Section 508 of the Standard Specifications.
 See special provision for Mechanical Splicers.
 See approved list of bar splicer assemblies and mechanical splicers for alternatives.

BSD-1

7-1-10

| | | | |
|--|-------------------------|----------------|-----------|
| FILE NAME = | USER NAME = woodshankr1 | DESIGNED - RLW | REVISED - |
| MAIN1-0366A29-details.dgn | | DRAWN - RLW | REVISED - |
| PLOT SCALE = 100.0000' / IN. | | CHECKED - | REVISED - |
| PLOT DATE = Dec 28, 2010 - 07:18:21 AM | | DATE - | REVISED - |

STATE OF ILLINOIS
DEPARTMENT OF TRANSPORTATION

BAR SPLICER ASSEMBLY AND MECHANICAL SPLICER DETAILS

SCALE: SHEET NO. 6 OF 6 SHEETS STA. TO STA.

| | | | | |
|--------------------|-------------------|---------------|---------------------------|--------------|
| F.A.S. RTE. 2247 | SECTION (13C-BR1) | COUNTY BUREAU | TOTAL SHEETS 14 | SHEET NO. 14 |
| CONTRACT NO. 66A29 | | | ILLINOIS FED. AID PROJECT | |