

WEST ABUTMENT ELEVATION
(Looking West)

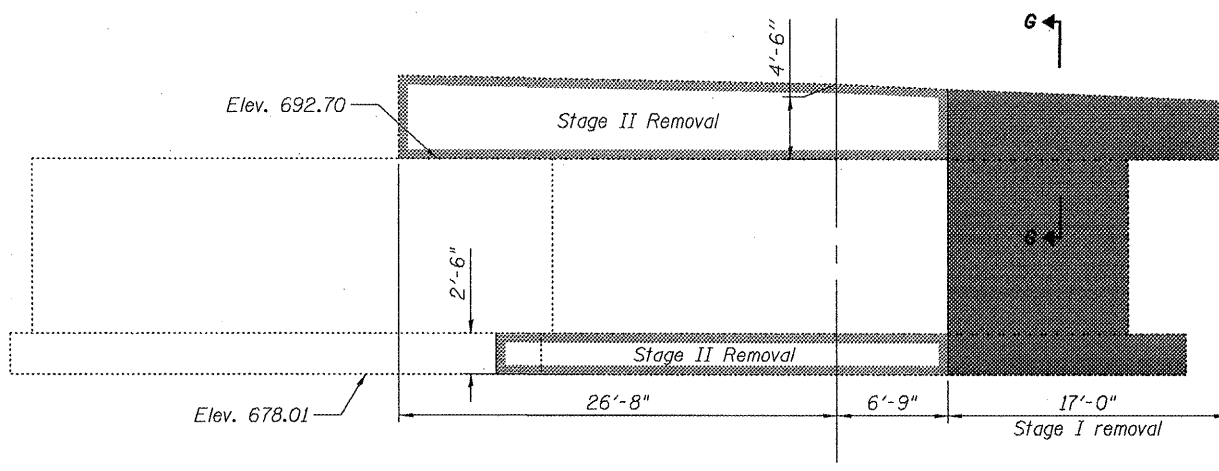

EAST ABUTMENT ELEVATION
(Looking East)

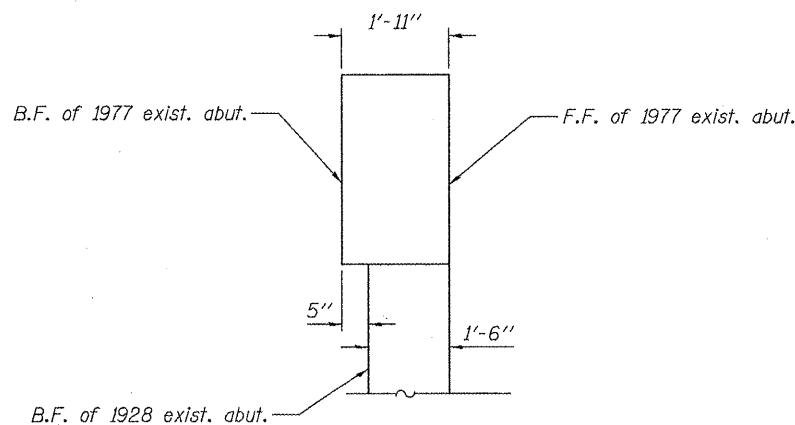

SECTION F-F

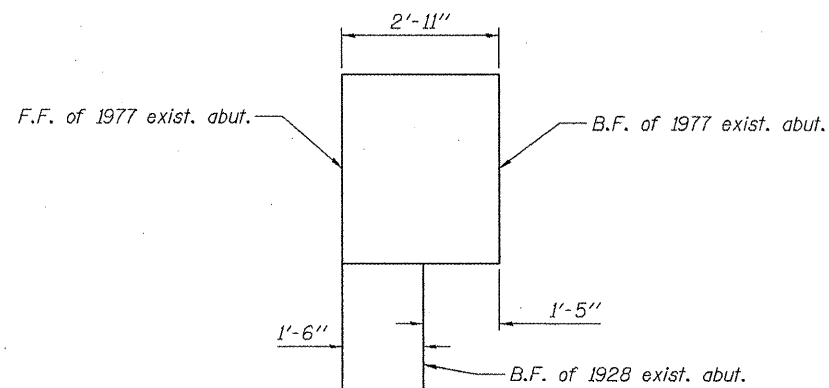

SECTION G-G

NOTE
For locations of sections H-H,
J-J & K-K see sheet 6 of 14.

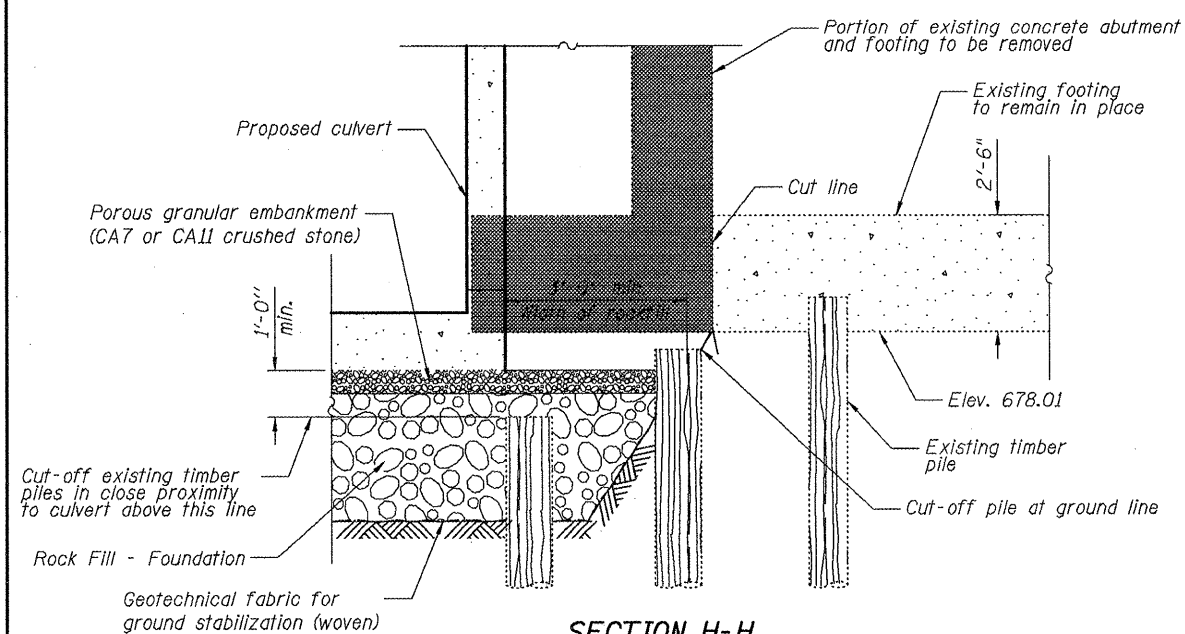

SECTION H-H

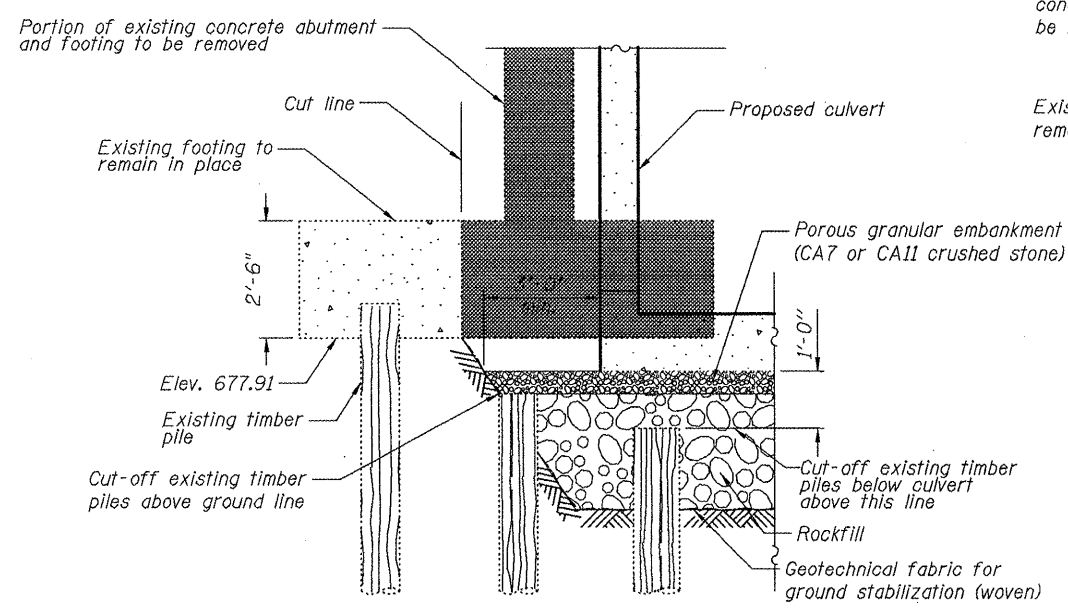

SECTION J-J

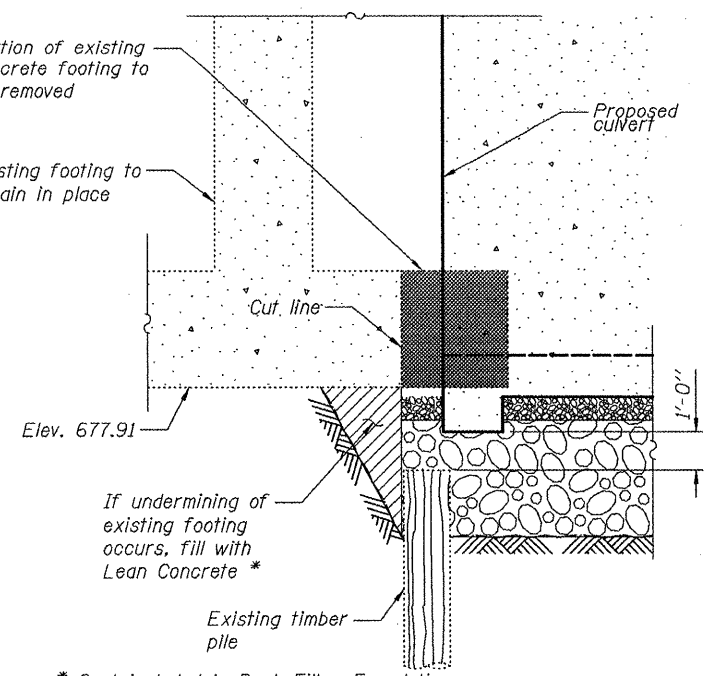

SECTION K-K