

DETAILS OF MAILBOX TURNOUTS

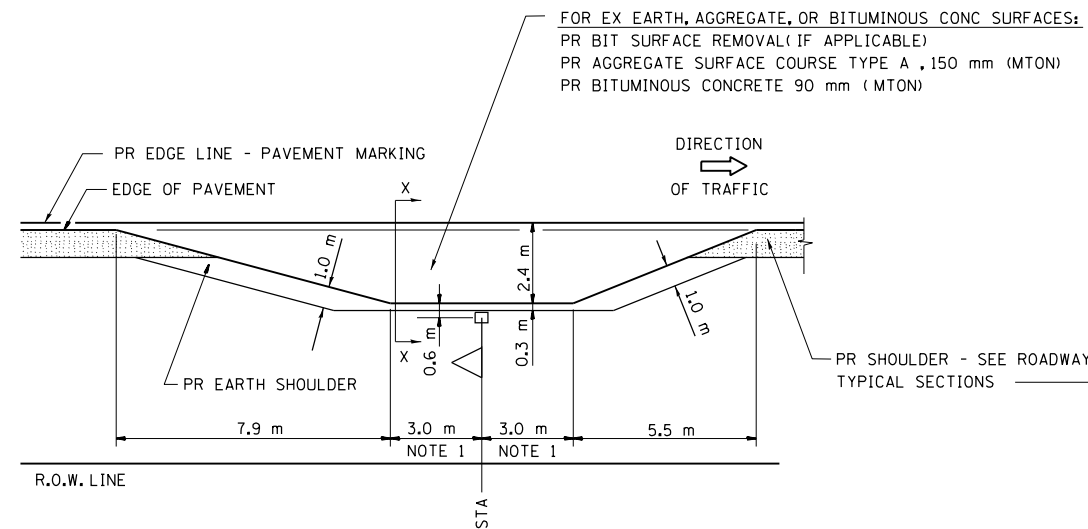

PLAN - MAILBOX TURNOUTS

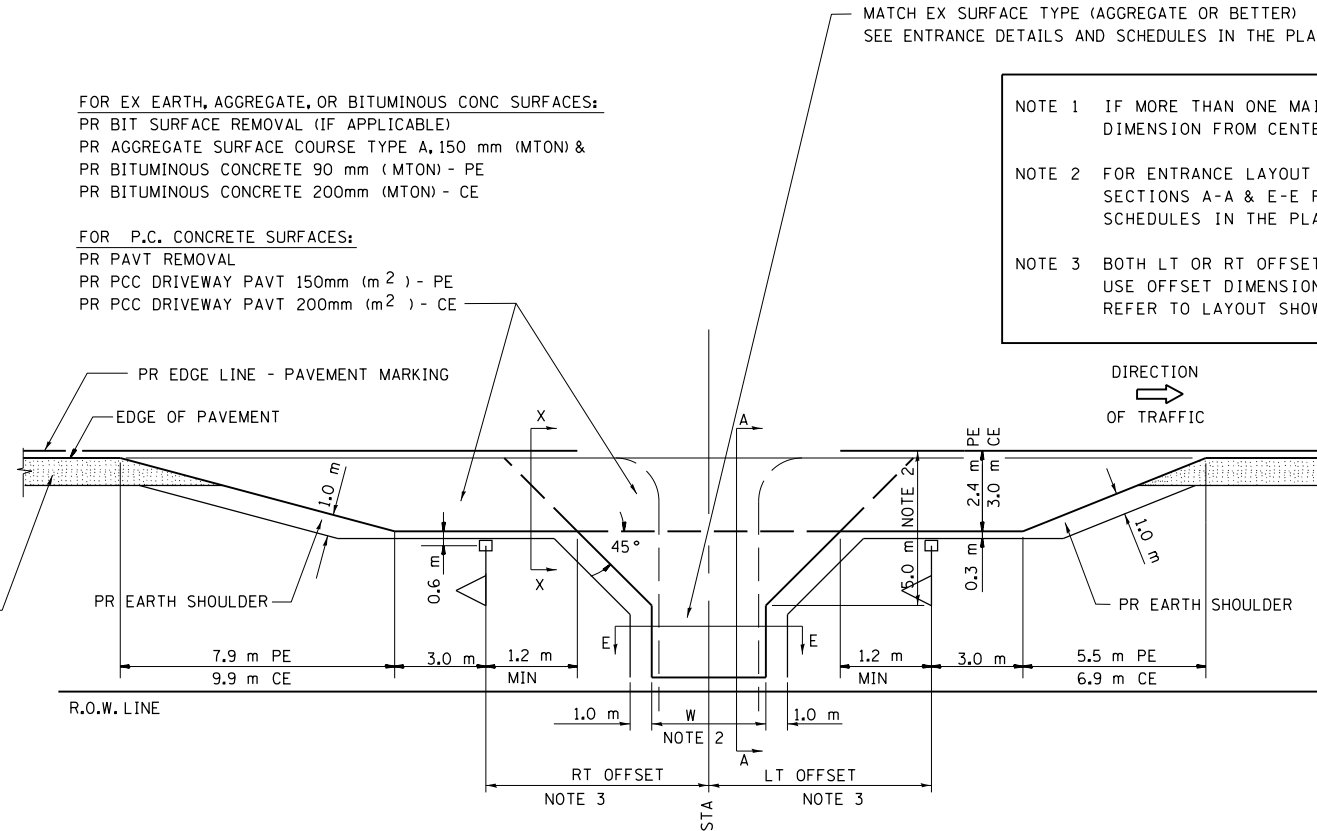

PLAN - COMBINED MAILBOX TURNOUT WITH TRAILING OR LEADING ENTRANCE

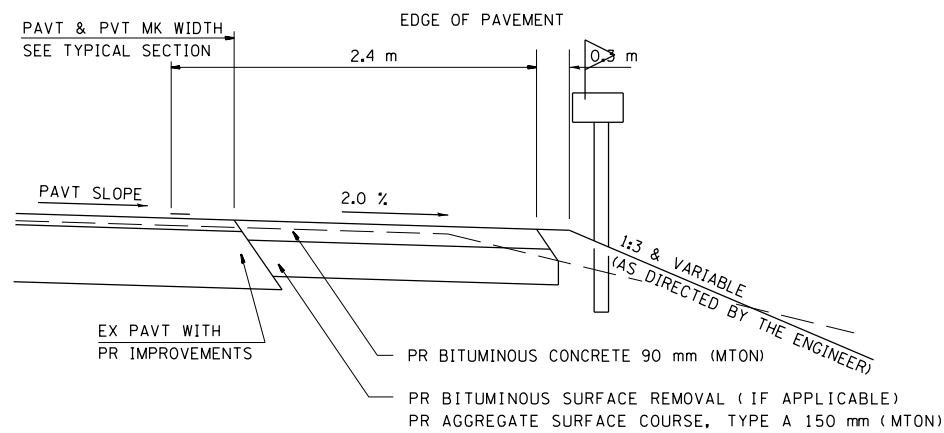

SECTION X-X THRU MAILBOX TURNOUT
 ALSO APPLIES TO MAILBOX TURNOUTS COMBINED WITH EX EARTH, AGGREGATE, OR BITUMINOUS PE & FE

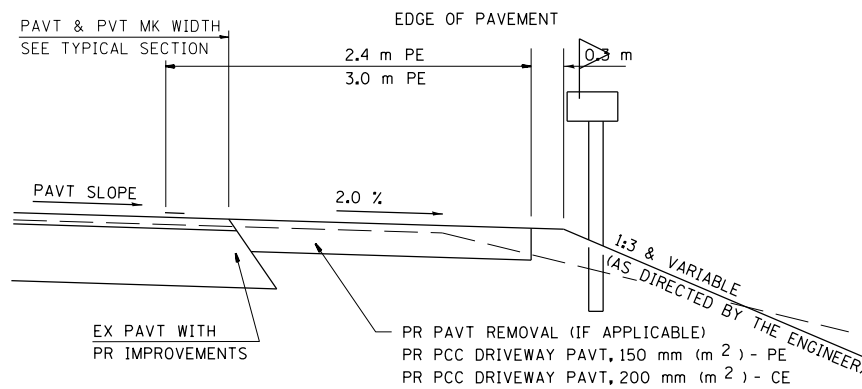

SECTION X-X THRU MAILBOX TURNOUT
 COMBINED WITH EX CONC PE OR CE

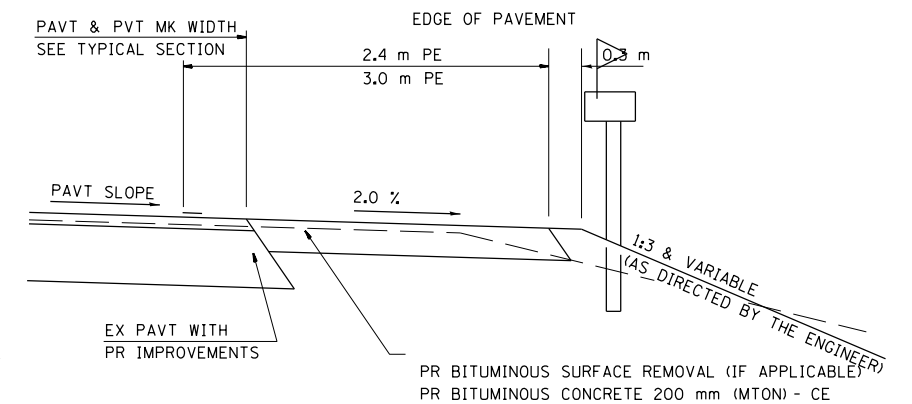

SECTION X-X THRU MAILBOX TURNOUT
 COMBINED WITH EX EARTH, AGGREGATE, OR BITUMINOUS CE

FILE NAME =	USER NAME = laughlinc1	DESIGNED -	REVISED -
et:\pwork\pwork\laughlinc1\0217938\06	2C22-shit-3rmrural.dgn	DRAWN - CADD	REVISED -
3RMRURAL.DGN	PLOT SCALE = 48.000' / in.	CHECKED - JCN	REVISED -
	PLOT DATE = Dec-16-2010 11:52:10AM	DATE - FEBRUARY 23, 1999	REVISED -

**STATE OF ILLINOIS
 DEPARTMENT OF TRANSPORTATION**

**DETAILS FOR RURAL
 ENTRANCE & MAILBOX TURNOUT**

SCALE: SHEET NO. 2 OF 2 SHEETS STA. TO STA.

F.A.P. RTE.	SECTION	COUNTY	TOTAL SHEETS	SHEET NO.
315	116RS-4	LOGAN	27	26
CONTRACT NO. 72C22				
FED. ROAD DIST. NO.		ILLINOIS FED. AID PROJECT		