

PUBLIC ROAD

COMMERCIAL (P.C.C.)

COMMERCIAL (HOT-MIX ASPHALT)

PRIVATE ENTRANCE (P.C.C.)

PRIVATE ENTRANCE (HOT-MIX ASPHALT)

FIELD ENTRANCE (AGGREGATE)

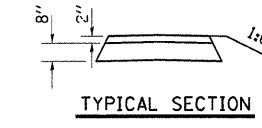

TYPICAL SECTION

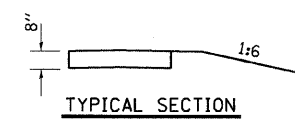

TYPICAL SECTION

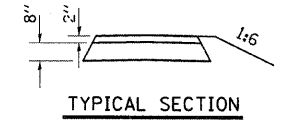

TYPICAL SECTION

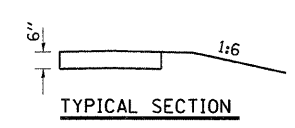

TYPICAL SECTION

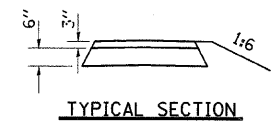

TYPICAL SECTION

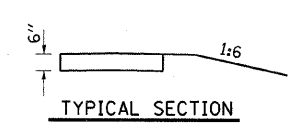

TYPICAL SECTION

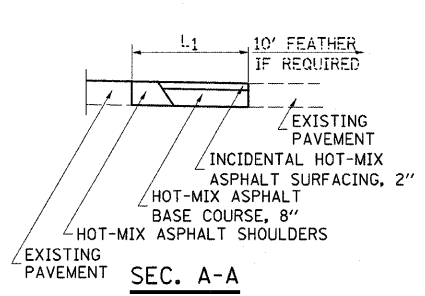

SEC. A-A

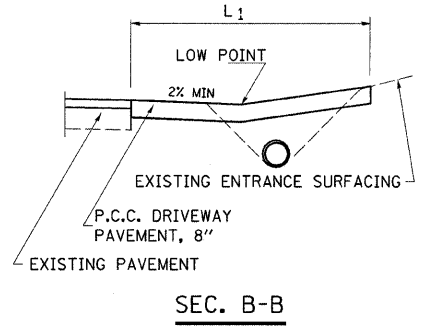

SEC. B-B

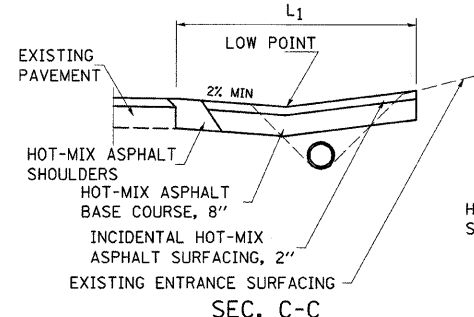

SEC. C-C

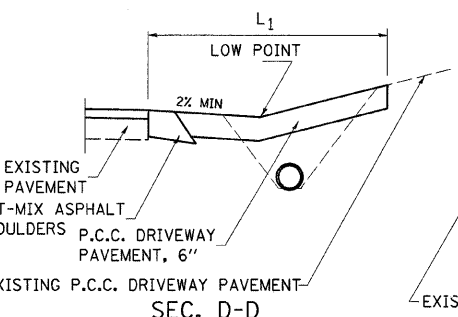

SEC. D-D

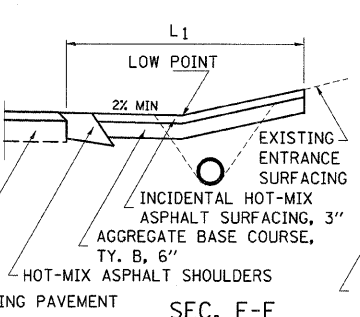

SEC. E-E

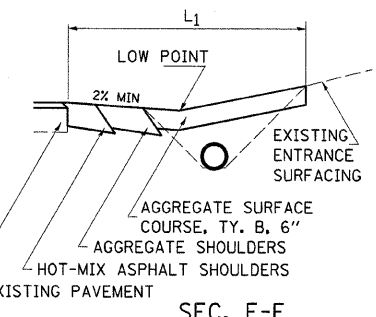

SEC. F-F

ENTRANCE SCHEDULE

TYPE	SIDE/ STATION	WIDTH	LENGTH		RADIUS	AGGREGATE BASE, COURSE, TY. B, 6"	HOT-MIX ASPHALT BASE COURSE, 8"	AGGREGATE SURFACE COURSE, TYPE B	INCIDENTAL HOT-MIX ASPHALT SURFACING	P.C.C. DRIVEWAY PAVEMENT		PCC PAVEMENT 8"
			L1	L2						6"	8"	
PE	LT 1034+60	14	10	16	10	9.9			4.9			
PE	LT 1036+29	10	10	11	10	15.6			7.7			

CULVERT SCHEDULE

STATION	PIPE CULVERTS, CLASS D, TYPE I 18"	
	FOOT	EACH
LT 1034+60	24.0	2.0
TOTAL	24.0	2.0

NOTES

L1 = DISTANCE FROM EDGE OF PAVEMENT TO RADIUS POINT OR MAXIMUM DISTANCE OF 30'.
L2 = DISTANCE FROM RADIUS POINT OR MAXIMUM DISTANCE OF 30' FROM EDGE OF PAVEMENT TO R.O.W. LINE
MATERIAL USED TO CONSTRUCT L2 LENGTH SHALL BE THE SAME TYPE OF MATERIAL AS THE EXISTING ENTRANCE

THE THICKNESS OF THE HOT-MIX ASPHALT SHOULDERS THROUGH COMMERCIAL ENTRANCES (HOT-MIX ASPHALT) AND PUBLIC ROADS SHALL BE 10". THE COST OF THE EXTRA THICKNESS SHALL BE INCLUDED WITH THE HOT-MIX ASPHALT SHOULDERS PAY ITEM.

THE COST OF THE BITUMINOUS MATERIALS AND AGGREGATE (PRIME COAT) FOR ENTRANCES AND PUBLIC ROAD APPROACHES SHALL BE INCLUDED IN THE PAY ITEM INCIDENTAL HOT-MIX ASPHALT SURFACING.

HOT-MIX ASPHALT SHOULDERS SHALL NOT BE CONSTRUCTED THROUGH PCC ENTRANCE OR PUBLIC ROAD APPROACH.

FE=FIELD ENTRANCE PRA - PUBLIC ROAD APPROACH
PE=PRIVATE ENTRANCE MBT - MAILBOX TURNOUT
CE=COMMERCIAL ENTRANCE